

Paddle-wheel flow transmitter/ threshold detector



- Indication, monitoring, transmitting and On/Off control in one device
- Selectable outputs (transistor or relay)
- Automatic calibration: Teach-In
- Process value output: 4... 20 mA

Type 8032 can be combined with...



Type 8802-YG-I
(2300 + 8692)
ELEMENT Control valve



Type 8792
Positioner
SideControl

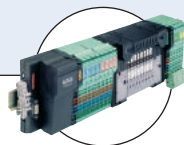

Type 8644-P AirLINE
Valve island with
electronic I/O



Type 8041
Flow sensor (only with
SE32 remote)



Type 8030
Flow sensor (only with
SE32 remote)

This intelligent transmitter/threshold detector with display is designed for use in clear, neutral or aggressive liquids and specially to switch a valve and to establish a monitoring system or an On/Off control loop.

The switching points can be configured with the 3 keys below the display.

The compact 8032 is available with On/Off output or with process value output.
The remote 8032 has a transistor output.

The connection to the process in the piping is done with standard INLINE fittings.

General data	
Compatibility	With fittings S030 (see corresponding data sheet)
Materials	Housing, cover Front panel folio / Screws Cable plug / connector M12 Wetted parts materials: Fitting, sensor armature / Seal Paddle-wheel / Axis, bearings Wall-mounted holder
	PC, glass fibre reinforced Polyester / Stainless steel PA / PA or CuZn, nickel-plated Brass, stainless steel, PVC, PP or PVDF / FKM (EPDM option) PVDF / Ceramics PVC
Display	8-digit LCD with backlighting
Electrical connections	Cable plug acc. to EN 175301-803, free positionable male M12 connector, 5 pins or male M12 connector, 8 pins
Panel-mounted version	Terminal strips
Voltage supply cable	0.5 mm ² max. cross section; max. 100 m length, shielded
Remote sensor connection	0.5 mm ² max. cross section; max. 50 m length, shielded

Complete device data (fitting S030 + electronic module SE32)	
Pipe diameter	DN06 to DN65
Measuring range	0.3 to 10 m/s
Medium temperature	0 to 50°C (32 to 122°F) (with PVC fitting) / 0 to 80°C (32 to 176°F) (with PP fitting) / -15 to 100°C (5 to 212°F) (with stainless steel, brass or PVDF fitting)
Fluid pressure max.	PN10 (145.1 PSI) (with plastic fitting) - PN16 (232.16 PSI) (with metal fitting)
Viscosity / Pollution	300 cSt. max. / 1% max. (particle size 0.5 mm max.)
Accuracy¹⁾	Teach-In Standard K-factor
	±1% of F.S.* ±(1% of F.S.* + 3% o. Reading)
Operating mode	Threshold: window or hysteresis
Linearity¹⁾	±0.5% of F.S.*
Repeatability¹⁾	≤ 0.4% of Reading

* F.S. = Full scale (10 m/s)

¹⁾ Under reference conditions i.e. measuring fluid = water, ambient and water temperature = 20°C (68°F), applying the minimum inlet and outlet pipe straights, matched inside pipe dimensions.

Electrical data	
Operating voltage Compact version Remote version	Filtered and regulated 12-36 V DC $\pm 10\%$ Depends on the sensor: 8041: 18-30 V DC 8020, 8030: 12-30 V DC other: min. 12 V DC, max. 30 V DC
Reversed polarity of DC	Protected
Current consumption Compact version Remote version	≤ 90 mA (without load) ≤ 50 mA (without load) + consumption of the sensor
Input Frequency (remote version)	Pulse signal: 2 to 400 Hz input impedance: 10 k Ω
Outputs Transistor Relay (compact version) Process value (compact version)	NPN and/or PNP (selectable), open collector, max. 700 mA, 500 mA max. per transistor if both transistor outputs are wired, 0 to 300 Hz NPN-output: 0.2 - 36 V DC PNP-output: Power supply protected against short circuit. 3 A/250 V AC or 3 A/30 V DC; [3 A/48 V AC or 3 A/30 V DC] ²⁾ . 4 ... 20 mA, galvanic insulation Loop resistance: 1300 Ω at 36 V DC, 1000 Ω at 30 V DC, 700 Ω at 24 V DC, 450 Ω at 18 V DC, 200 Ω at 12 V DC
Environment	
Ambient temperature	-10 to +60°C (14 to 140°F) (operating and storage)
Relative humidity	$\leq 80\%$, without condensation
Standards, directives and approvals	
Protection class	IP65 with connector plugged-in and tightened correctly
Standard, directives EMC Security Pressure (Fitting S030, DN06 to DN65, in PVC, PP, PVDF, stainless steel or brass) Vibration / Shock	EN 610006-2, 610006-3 EN 61010-1 Complying with article 3 of Chap. 3 from 97/23/CE directive.* EN 60068-2-6 / EN 60068-2-27
Approvals UL-Recognized for US and Canada 	UL61010-1 + CAN/CSA-C22 No.61010-1
Specific technical data of UL-recognized products for US and Canada	
Ambient temperature	0 to +40°C (32 to 104°F)
Height above sea level	max. 2000 m
Intended for an inner pollution	Grade of pollution 2
Installation category	Category I

²⁾ if 4... 20 mA and relay

* For the 97/23/CE pressure directive, the device can only be used under following conditions (depend on max. pressure, pipe diameter and fluid).

Type of fluid	Conditions
Fluid group 1, chap. 1.3.a	DN ≤ 25 only
Fluid group 2, chap. 1.3.a	DN ≤ 32 or DN > 32 and PN*DN ≤ 1000
Fluid group 1, chap. 1.3.b	PN*DN ≤ 2000
Fluid group 2, chap. 1.3.b	DN ≤ 200

Accuracy diagram

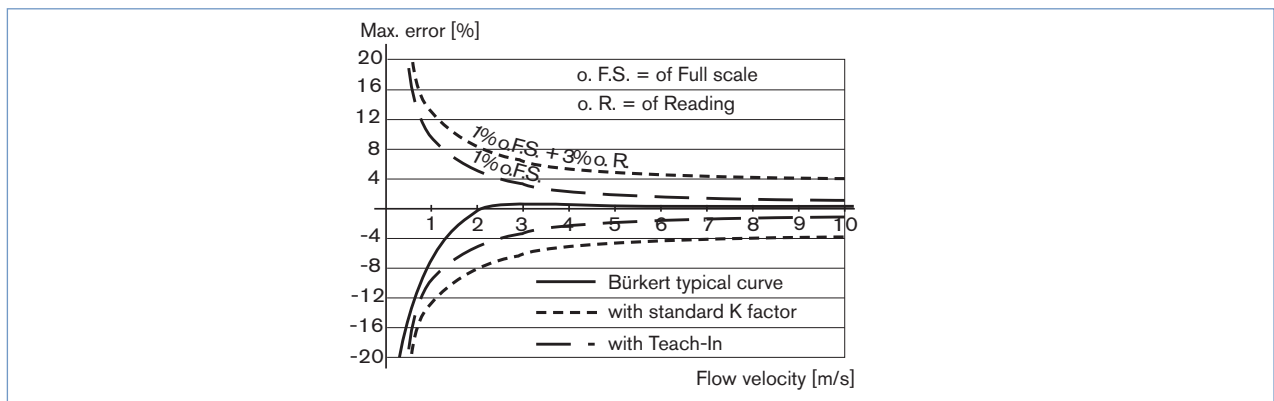

Operation and display

The device can be calibrated by means of the K-factor, or via the Teach-In function.
User adjustments, such as engineering units, output, filter, bargraph are carried out on site.

► Indication in operating mode/Display

- measured flow
- high threshold value
- low threshold value

► Parameter definition

- engineering units (International measuring units)
- K-factor/Teach-In function
- selection of switching mode (window, hysteresis) (see main features)
- selection of threshold value (see main features)
- delay
- filter
- 10-segment bargraph (select min. and max. value)
- Password protects the access to the menu

► Test

- switching threshold test with flow simulation
- Calibration of the 4... 20 mA current output

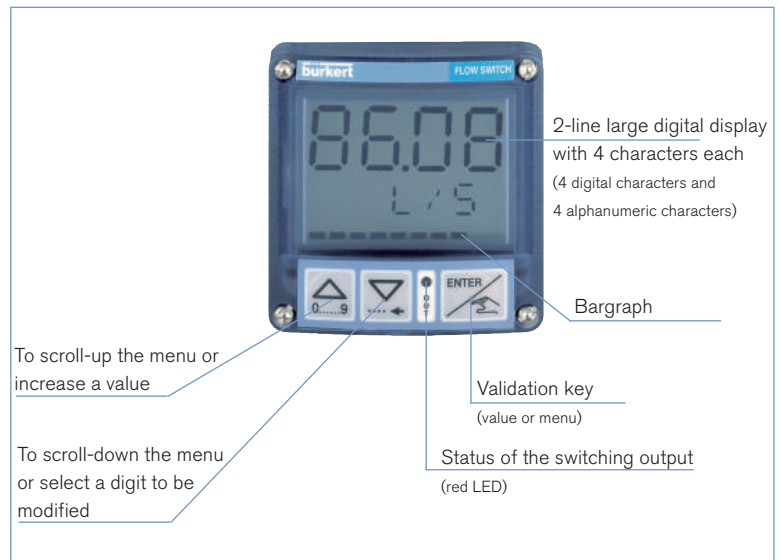

Main features

8032 with standard On/Off output

- 2 switching modes for the output, either hysteresis or window, inverted or not

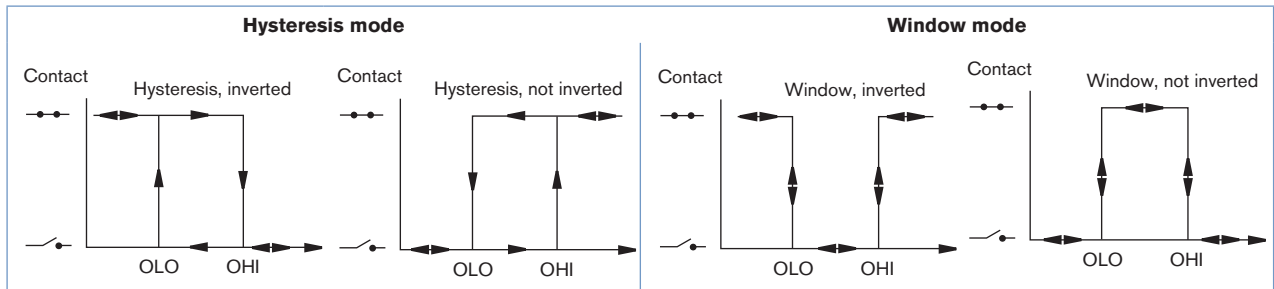

- Configurable delay before switching
- Possible outputs depending on the version: relay, transistor NPN, transistor PNP

8032 with current output for the measurement value

- 4... 20 mA output
- 4... 20 mA output + relay output

Design and principle of operation

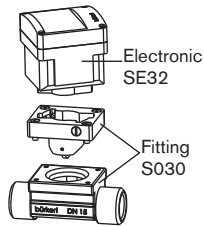

The compact 8032 is built up with an electronic module SE32 associated to a fitting S030 with integrated measurement paddle-wheel. The electrical connection is provided via cable plug according to EN 175301-803 and/or a M12 multipin connector.

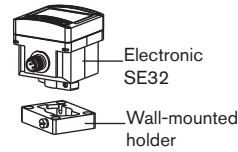

The wall-mounted variant is built up with an electronic module SE32 associated to a wall-mounted holder. The electrical connection is provided via two M12 multipin connector.

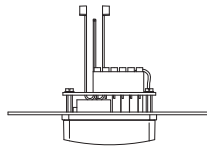
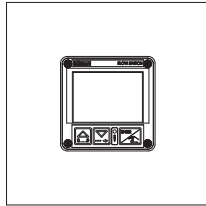

The panel-mounted variant is made up of an electronic module SE32 and a protection plate. The electrical connection is provided via a terminal strip located on the protection plate.

When liquid flows through the pipe, the 4 magnets, inserted in the paddle-wheel set in rotation, produce a frequency signal in the transducer. The frequency is proportional to the flow velocity of the fluid. A conversion coefficient (K factor, available in the instruction manual of the fitting S030), specific to each pipe (size and material) enables the conversion of this frequency into a flow rate.

Installation



The SE32 electronics can easily be installed into any Bürkert INLINE fitting system Type S030 by means of a Quarter-Turn. Minimum straight upstream and downstream distances must be observed. According to the pipe's design, necessary distances can be bigger or use a flow conditioner to obtain the best accuracy. For more information, please refer to EN ISO 5167-1.

EN ISO 5167-1 specifies the straight inlet and outlet distances that must be complied with when installing fittings in pipelines in order to achieve calm flow conditions. The most important layouts that could lead to turbulence in the flow are shown below, together with the associated minimum inlet and outlet distances. These ensure calm, problem-free measurement conditions at the measurement point.

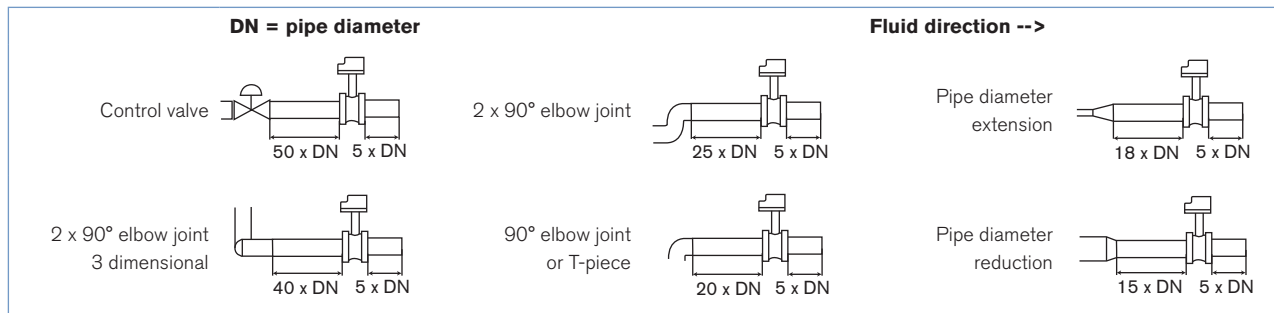

The device can be installed into either horizontal or vertical pipes.

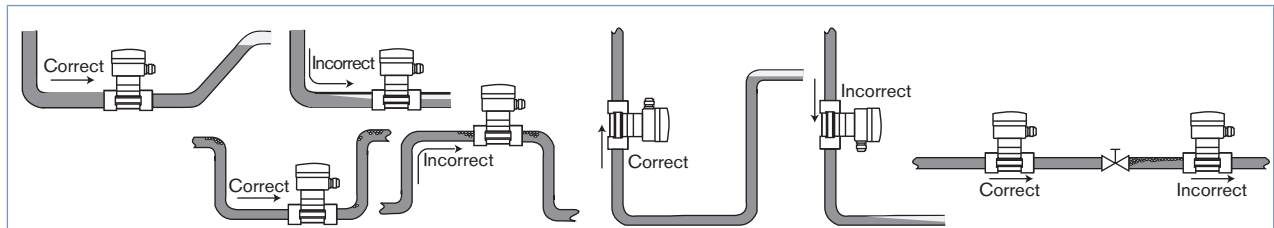

Pressure and temperature ratings must be respected according to the selected fitting material. The suitable pipe size is selected using the diagram Flow/Velocity/DN.

The device is not designed for gas flow measurement.

Pressure/temperature chart

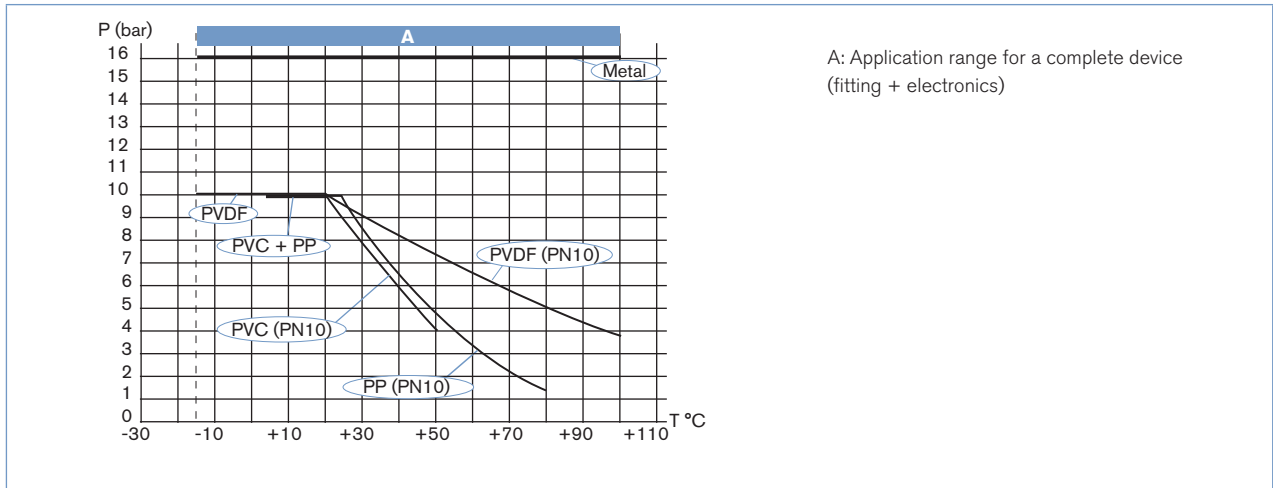
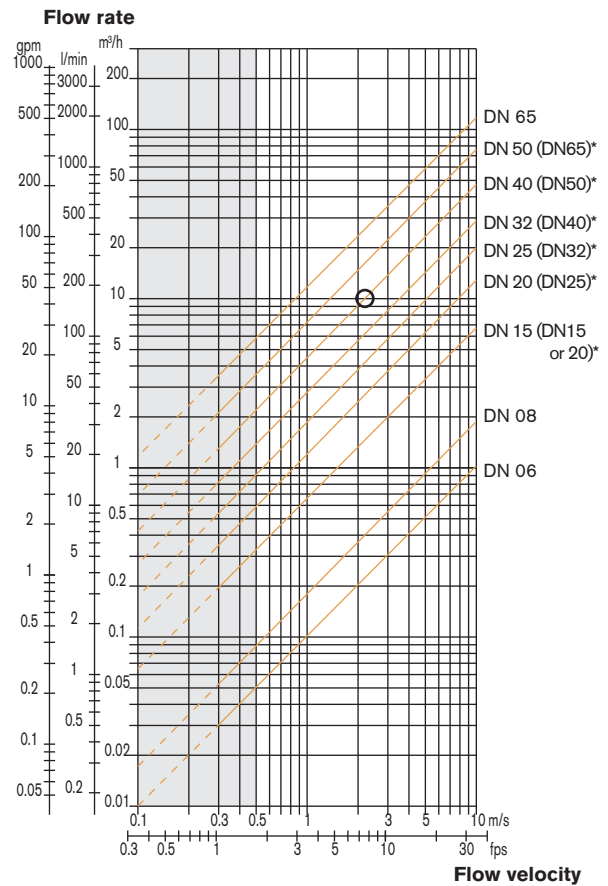

Diagram Flow/Velocity/DN

Example:

- Specification of nominal flow: 10 m³/h
- Ideal flow velocity: 2... 3 m/s

For these specifications, the diagram indicates a pipe size of DN40 [or DN50 for (*) mentioned fittings]



- * for following fittings with:
- external threads acc. to SMS 1145
- weld ends acc. to SMS 3008, BS 4825 / ASME BPE or DIN 11850 Series 2
- Clamp acc. to SMS 3017/ ISO 2852, BS 4825 / ASME BPE or DIN 32676

Dimensions

8032 compact

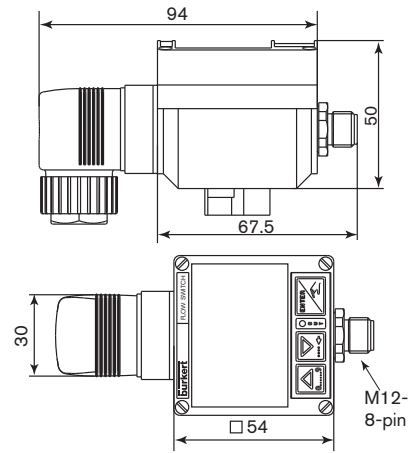
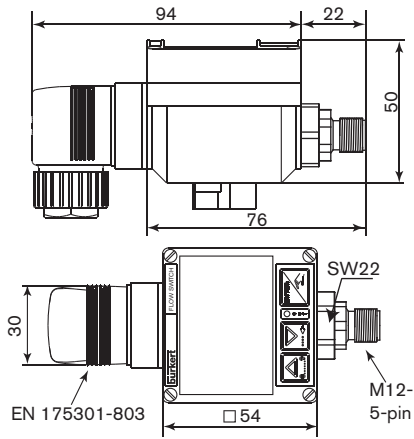

DN [mm]	H [mm]
06	79.5
08	79.5
15	84.5
20	82.0
25	82.2
32	85.8
40	89.6
50	95.7
65	95.7

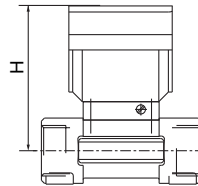

8032 wall-mounted

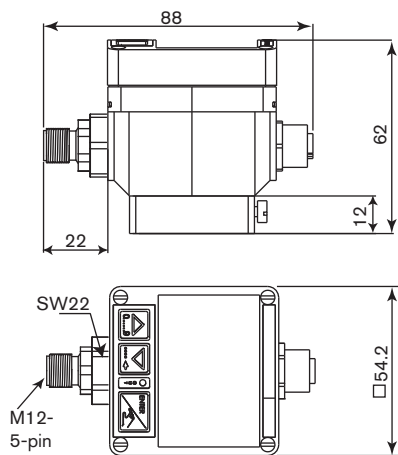

8032 panel-mounted

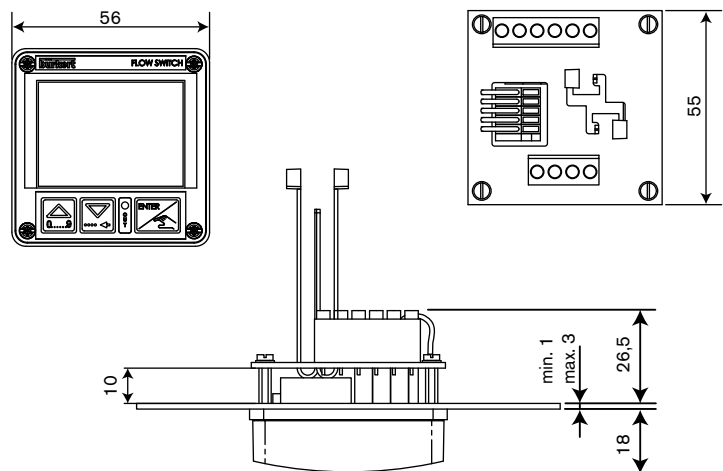

Ordering chart for transmitter/threshold detector Type 8032

A compact Type 8032 consists of:

- an electronic module SE32
- an INLINE fitting S030 (DN06 - DN65) (Refer to corresponding data sheet - has to be ordered separately)

Operating voltage	Outputs	Agreements	Electrical connection	Item no.
12-36 V DC	NPN	-	Cable plug EN 175301-803*	436 474
	PNP	-	Cable plug EN 175301-803*	434 871
	NPN and PNP	-	Free positionable male M12 connector, 5 pins	436 473
		UL-Recognized for US and Canada 	Free positionable male M12 connector, 5 pins	553 431
	Relay	-	Free positionable male M12 connector, 5 pins and cable plug EN 175301-803*	436 475
	4... 20 mA + relay	-	Male M12 connector, 8 pins and cable plug EN 175301-803*	560 547
	4... 20 mA + relay	-	Free positionable male M12 connector, 5 pins and cable plug EN 175301-803	560 402
	4... 20 mA	-	Free positionable male M12 connector, 5 pins	560 403

* Europe/Asia (G/Rc): M16 x 1.5 mm cable plug
USA/CDN (NPT): NPT1/2 cable plug

A wall- or panel- mounted Type 8032 consists of:

- a wall- or a panel- mounted electronic module SE32
- a flow sensor Type 8020, 8030, 8030-HT, 8041 or 8070 - frequency output with pulse signal
(Refer to corresponding data sheet - has to be ordered separately)

Description	Voltage supply	Input	Outputs	Electrical connection	Item no.
Wall-mounted	12-30 V DC	Frequency	NPN and PNP	Free positionable male M12 connector, 5 pins and female M12 connector, 4 pins	448 861
Panel-mounted	12-30 V DC	Frequency	NPN and PNP	Terminal strips	558 181

Ordering chart for accessories (to be ordered separately)

Description	Item no.
Male M12 connector, 4 pins, with plastic threaded locking ring, for remote version	448 856
Male M12 connector, 4 pins, moulded on cable (2 m, shielded), for remote version	448 857
Female M12 connector, 5 pins, with plastic threaded locking ring	917 116
Female M12 connector, 5 pins, moulded on cable (2 m, shielded)	438 680
Female M12 connector, 8 pins, with plastic threaded locking ring	444 799
Female M12 connector, 8 pins, moulded on cable (2 m, shielded)	444 800
Cable plug EN 175301-803 with cable gland (Type 2508)	438 811
Cable plug EN 175301-803 with NPT1/2" reduction without cable gland (Type 2509)	162 673

Interconnection possibilities with other Bürkert products

Compact version



Wall-or panel- mounted version

