

Incremental encoders

Blind hollow shaft $\varnothing 10$ to $\varnothing 16$ mm

200...2048 pulses per revolution

ITD 40 A 4



ITD 40 A 4 with blind hollow shaft

Features

- Encoder with blind hollow shaft $\varnothing 10...16$ mm
- Max. 2048 pulses per revolution
- Optical sensing
- Mounting by torque support
- TTL or HTL output signals
- Cable output radial or axial

Optional

- Cable with connector
- Extended operating temperature range

Technical data - electrical ratings

Voltage supply	5 VDC $\pm 5\%$ 8...30 VDC
Reverse polarity protection	Yes
Consumption w/o load	≤ 100 mA
Pulses per revolution	200...2048
Reference signal	Zero pulse, width 90°
Sensing method	Optical
Output frequency	≤ 120 kHz
Output signals	A, B, N + inverted
Output stage	TTL linedriver (short-circuit proof) HTL push-pull (short-circuit proof)
Interference immunity	DIN EN 61000-6-2
Emitted interference	DIN EN 61000-6-3

Technical data - mechanical design

Size (flange)	$\varnothing 80$ mm
Shaft type	$\varnothing 10...16$ mm (blind hollow shaft)
Motor shaft tolerance	0.25 mm axial 0.1 mm radial
Mounting kit	050
Protection DIN EN 60529	IP 65
Operating speed	≤ 8000 rpm ≤ 5000 rpm IP 65 ($>70^\circ\text{C}$)
Starting torque	≤ 0.01 Nm ($+20^\circ\text{C}$)
Materials	Housing: aluminium, black, powder-coated Shaft: stainless steel
Operating temperature	$-20...+70^\circ\text{C}$ $-20...+100^\circ\text{C}$
Relative humidity	90 % non-condensing
Resistance	DIN EN 60068-2-6 Vibration 10 g, 55-2000 Hz DIN EN 60068-2-27 Shock 100 g, 11 ms
Connection	Cable 1 m
Weight approx.	550 g

Incremental encoders

Blind hollow shaft $\varnothing 10$ to $\varnothing 16$ mm
200...2048 pulses per revolution

ITD 40 A 4

Part number

ITD 40 A 4

--	--	--	--	--	--	--	--	--	--

050

Mounting kit
050 Mounting accessory kit 050

Protection
IP54 IP 54
IP65 IP 65

Blind hollow shaft
10 $\varnothing 10$ mm
11 $\varnothing 11$ mm
12 $\varnothing 12$ mm
12.7 $\varnothing 12.7$ mm
14 $\varnothing 14$ mm
15 $\varnothing 15$ mm
16 $\varnothing 16$ mm

Operating temperature
S -20...+70 °C
E -20...+100 °C

Connection
KR1 Cable 1 m, radial
KA1 Cable 1 m, axial

Output signals
BI A, A inv, B, B inv
NI A, A inv, B, B inv, 0, 0 inv

Voltage supply / signals
T 5 VDC / TTL level, linedriver
H 8...30 VDC / HTL level, push pull
R 8...30 VDC / TTL level, linedriver

Pulse number - see table

Pulse number

200	500	720	1024	2048
360	512	1000	2000	

Incremental encoders

Blind hollow shaft $\varnothing 10$ to $\varnothing 16$ mm
200...2048 pulses per revolution

ITD 40 A 4

Output signals

Clockwise rotation when looking at the mounting side.

BI-Output signals

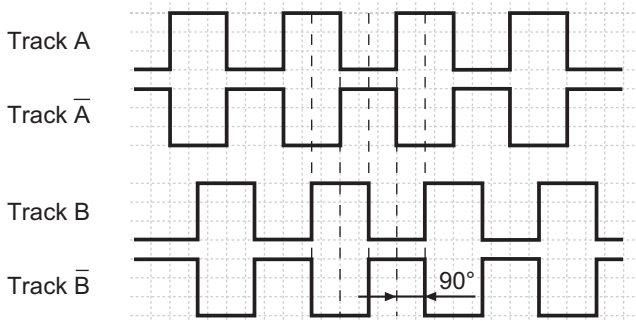

NI-Output signals

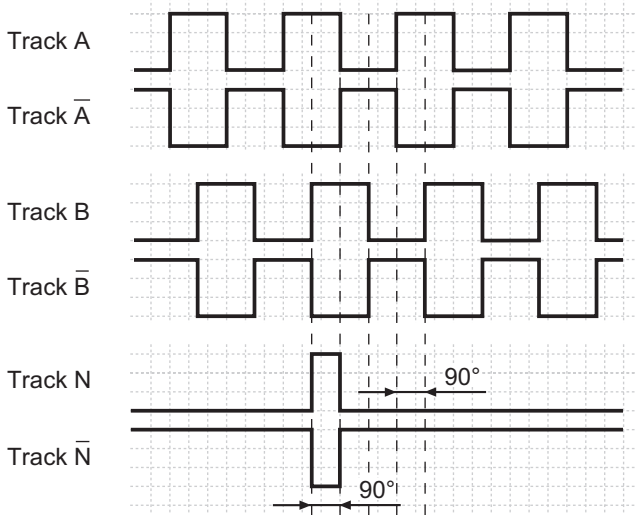

Terminal assignment

Core colour	Assignment
brown	Track A
green	Track A inv.
grey	Track B
pink	Track B inv.
red	Track N
black	Track N inv.
brown 0,5 mm ²	UB
white 0,5 mm ²	GND
blue	UB-Sense
white	GND-Sense
transparent	Shield/Housing

Trigger level

Outputs	Linedriver
Output level High	≥ 2.4 V
Output level Low	≤ 0.5 V
Load	≤ 70 mA

Outputs	Push-pull short-circuit proof
Output level High	$\geq UB - 3$ V
Output level Low	≤ 1.5 V
Load	≤ 70 mA

Dimensions

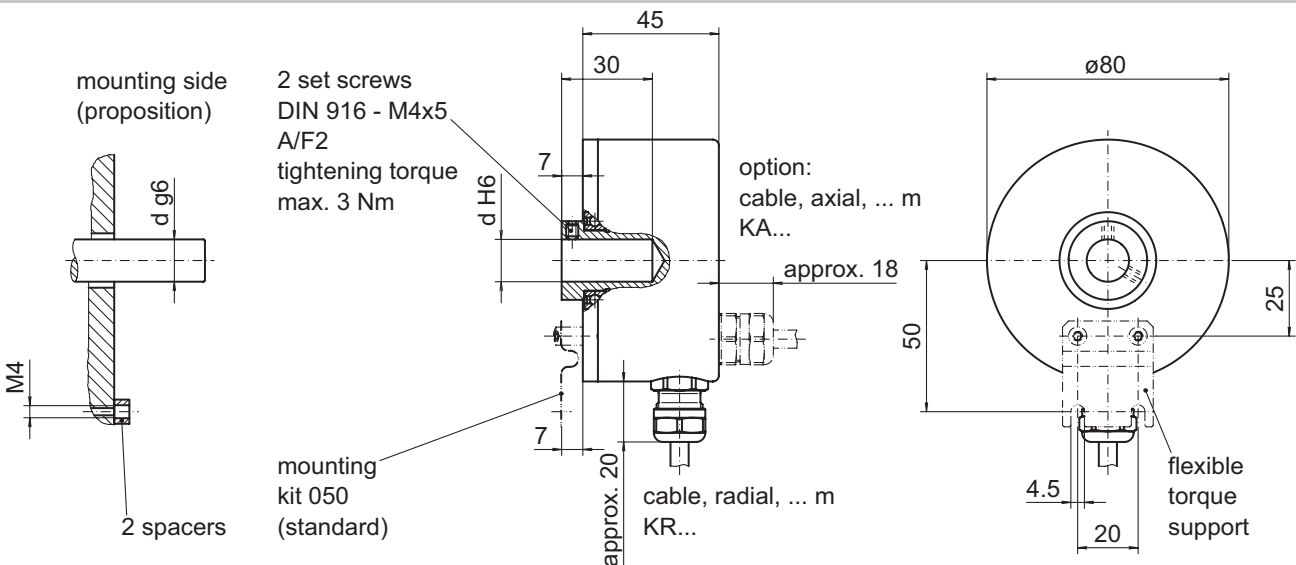

026-5

Incremental encoders
Blind hollow shaft \varnothing 10 to \varnothing 16 mm
200...2048 pulses per revolution

ITD 40 A 4
