

# XAPM54H29

Harmony XAP, XB2 SL, Empty control station, aluminium, blue, undrilled, with ISO cable entries, 85 x 310 x 77 mm



## Main

Range of product	Harmony XAP
Product or component type	Die-cast empty control station
Device short name	XAPM
Product front plate size	85 x 310 mm
Usable depth	74.5 mm
Number of cut-out	Undrilled
Colour of base of enclosure	Blue
Colour of cover	Blue
Material	Aluminium alloy
Cable entry	1 hole without blanking plug for ISO 429248 cable gland, clamping capacity: 32 mm
Product mounting	Flush mounting
IP degree of protection	IP65 conforming to IEC 60529

## Complementary

Net weight	0.85 kg
------------	---------

## Environment

Protective treatment	TC
Ambient air temperature for storage	-40...70 °C
Ambient air temperature for operation	-40...70 °C
Electrical shock protection class	Class I conforming to IEC 60536 Class I conforming to NF C 20-030

## Packing Units

Unit Type of Package 1	PCE
Number of Units in Package 1	1
Package 1 Weight	987.667 g
Package 1 Height	12.2 cm
Package 1 width	9.0 cm
Package 1 Length	31.5 cm
Unit Type of Package 2	S03
Number of Units in Package 2	6
Package 2 Weight	6.635 kg
Package 2 Height	30.0 cm
Package 2 width	30.0 cm
Package 2 Length	40.0 cm

The information provided in this documentation contains general descriptions and/or technical characteristics of the performance of the products contained herein. This documentation is not intended as a substitute for and is not to be used for determining suitability or reliability of these products for specific user applications. It is the duty of any such user or integrator to perform the appropriate and complete risk analysis, evaluation and testing of the products with respect to the relevant specific application or use thereof. Neither Schneider Electric Industries SAS nor any of its affiliates or subsidiaries shall be responsible or liable for misuse of the information contained herein.

## Offer Sustainability

Sustainable offer status	Green Premium product
REACH Regulation	<a href="#">REACH Declaration</a>
REACH free of SVHC	Yes
EU RoHS Directive	Pro-active compliance (Product out of EU RoHS legal scope) <a href="#">EU RoHS Declaration</a>
Toxic heavy metal free	Yes
Mercury free	Yes
RoHS exemption information	<a href="#">Yes</a>
China RoHS Regulation	<a href="#">China RoHS Declaration</a>
Environmental Disclosure	<a href="#">Product Environmental Profile</a>
Circularity Profile	<a href="#">End Of Life Information</a>
California proposition 65	WARNING: This product can expose you to chemicals including: Di-isodecyl phthalate (DIDP), which is known to the State of California to cause birth defects or other reproductive harm. For more information go to <a href="http://www.P65Warnings.ca.gov">www.P65Warnings.ca.gov</a>

## Contractual warranty

Warranty	18 months
----------	-----------

Dimensions and Fixing

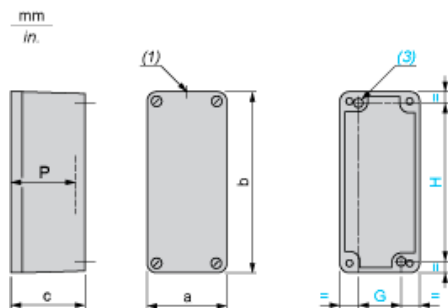

- (1) 1 hole, without blanking plug, for cable gland with 24 mm/0.94 in. maximum clamping capacity  
 (3) 2 x  $\varnothing$  5.6 mm/0.22 in. holes, depth 20 mm/0.79 in.

a		b		c		G		H		P	
mm	in.	mm	in.	mm	in.	mm	in.	mm	in.	mm	in.
80	3.15	310	12.20	77	3.03	50	1.97	295	11.61	74.5	2.93