

Programmable Controller

CC-Link IE Field Network
Waterproof/Dustproof Remote I/O Module
User's Manual

-NZ2GF12A4-16D
-NZ2GF12A4-16DE
-NZ2GF12A2-16T
-NZ2GF12A2-16TE
-NZ2GF12A42-16DT
-NZ2GF12A42-16DTE

Powered by
molex

This product was jointly developed and manufactured by Mitsubishi and Molex.

*Note that the warranty on this product differs from that on other programmable controller products.
(Refer to "WARRANTY" in this manual.)

COPYRIGHT

This document is protected by the law of copyright, whereby all rights established therein remain with the company Mitsubishi Electric Corporation. Reproduction of this document or parts of this document is only permissible within the limits of the legal determination of Copyright Law. Alteration or abridgement of the document is not permitted without the explicit written approval of the company Mitsubishi Electric Corporation.

PRECAUTIONS REGARDING WARRANTY

This product is jointly developed and manufactured with Molex. Thus, warranty information is different from that of other MELSEC products. Please confirm the following restrictions before purchase.

■ **Gratis Warranty Term**

Warranty period is one year after delivery.(Maximum of 18 months after produced)

■ **Repair and Analysis**

Please note that repairs and failure analysis are refused due to the structure of this product. Therefore, free replacement is arranged for the failure of our responsibility during the warranty period.

SAFETY PRECAUTIONS

(Read these precautions before using this product.)

Before using this product, please read this manual and the relevant manuals carefully and pay full attention to safety to handle the product correctly.

The precautions given in this manual are concerned with this product only. For the safety precautions of the programmable controller system, refer to the user's manual for the CPU module used.

In this manual, the safety precautions are classified into two levels: "⚠️ WARNING" and "⚠️ CAUTION".

WARNING

Indicates that incorrect handling may cause hazardous conditions, resulting in death or severe injury.

CAUTION

Indicates that incorrect handling may cause hazardous conditions, resulting in minor or moderate injury or property damage.

Under some circumstances, failure to observe the precautions given under "⚠️ CAUTION" may lead to serious consequences.

Observe the precautions of both levels because they are important for personal and system safety.

Make sure that the end users read this manual and then keep the manual in a safe place for future reference.

[Design Precautions]

WARNING

- When a communication failure occurs in the network, data in the master module are held. Check Data link status (each station) (SW00B0 to SW00B7) and configure an interlock circuit in the program to ensure that the entire system will operate safely.
 - When the module is disconnected due to a communication failure in the network or the CPU module is in the STOP status, all outputs are held or turned off according to the parameter setting. Configure an interlock circuit in the program to ensure that the entire system will always operate safely even in such a case. If not, an accident may occur due to an incorrect output or malfunction.
 - Outputs may remain on or off due to a failure of the module. Configure an external circuit for monitoring output signals that could cause a serious accident.
 - Do not use any "use prohibited" signals as a remote input or output signal. These signals are reserved for system use. Do not write any data to the "use prohibited" areas in the remote register. If these operations are performed, an accident may occur due to an incorrect output or malfunction.
-

[Design Precautions]

CAUTION

- Do not install the control lines or communication cables together with the main circuit lines or power cables. Keep a distance of 100mm or more between them. Failure to do so may result in malfunction due to noise.
 - During control of an inductive load such as a lamp, heater, or solenoid valve, a large current (approximately ten times greater than normal) may flow when the output is turned from off to on. Therefore, use a module that has a sufficient current rating.
-

[Installation Precautions]

WARNING

- Shut off the load power supply (all phases) used in the system before mounting or removing a module. Failure to do so may result in electric shock or cause the module to fail or malfunction.
-

[Installation Precautions]

CAUTION

- Use the module in an environment that meets the general specifications in this manual. Failure to do so may result in electric shock, fire, malfunction, or damage to or deterioration of the product.
 - Do not directly touch any conductive parts and electronic components of the module. Doing so can cause malfunction or failure of the module.
 - Securely fix the module with mounting screws. Failure to do so may cause the module to fail due to increasing effects of vibrations.
 - Securely connect the cable connectors. Poor contact may cause malfunction.
 - After the first use of the product, do not connect/remove the connector more than 50 times (IEC 61131-2 compliant). Exceeding the limit may cause malfunction.
-

[Wiring Precautions]

WARNING

- Shut off the load power supply (all phases) used in the system before wiring. Failure to do so may result in electric shock or cause the module to fail or malfunction.
-

[Wiring Precautions]

CAUTION

- Individually ground the FG metal fitting of the programmable controller with a ground resistance of 100 ohms or less. Failure to do so may result in electric shock or malfunction.
 - Check the rated voltage and terminal layout before wiring to the module, and connect the cables correctly. Connecting a power supply with a different voltage rating or incorrect wiring may cause a fire or failure.
 - Tighten the waterproof caps within the specified torque range. Undertightening can cause short circuit, fire, or malfunction. Overtightening can damage the waterproof cap, resulting in short circuit or malfunction.
 - The module meets IP67 only when all of the waterproof plugs and waterproof caps are attached and the cover of the station number setting switch is securely fixed with a screw.
 - Do not connect a communication cable to an I/O connector instead of to a communication connector. Both connectors are the same in form. Connecting the cable to a wrong connector may cause the module to fail or malfunction.
 - Prevent foreign matter such as dust or wire chips from entering the module. Such foreign matter can cause a fire, failure, or malfunction.
 - Place the cables in a duct or clamp them. If not, dangling cable may swing or inadvertently be pulled, resulting in damage to the module or cables or malfunction due to poor contact.
 - Do not install the control lines or communication cables together with the main circuit lines or power cables. Keep a distance of 100mm or more between them. Failure to do so may result in malfunction due to noise.
 - When disconnecting the cable from the module, do not pull the cable by the cable part. For the cable with connector, hold the connector part of the cable. Pulling the cable connected to the module may result in malfunction or damage to the module or cable.
 - When an overcurrent caused by an error of an external device or a failure of the programmable controller flows for a long time, it may cause smoke and fire. To prevent this, configure an external safety circuit, such as a fuse.
 - Wiring and replacement of a module must be performed by qualified maintenance personnel with knowledge of protection against electric shock. For wiring methods, refer to "INSTALLATION AND WIRING" in this manual.
-

[Startup and Maintenance Precautions]

WARNING

- Do not touch any connector while power is on. Doing so will cause electric shock or malfunction.
 - Shut off the load power supply (all phases) used in the system before cleaning the module or retightening screws or connector screws. Failure to do so may cause the module to fail or malfunction.
-

[Startup and Maintenance Precautions]

CAUTION

- Do not disassemble or modify the module. Doing so may cause failure, malfunction, injury, or a fire.
 - Do not drop or apply strong shock to the module. Doing so may damage the module.
 - Shut off the load power supply (all phases) used in the system before mounting or removing a module. Failure to do so may cause the module to fail or malfunction.
 - After the first use of the product, do not connect/remove the connectors more than 50 times (IEC 61131-2 compliant). Exceeding the limit may cause malfunction.
 - Before handling the module or connection cables, touch a conducting object such as a grounded metal to discharge the static electricity from the human body. Failure to do so may cause the module to fail or malfunction.
 - Startup and maintenance of a control panel must be performed by qualified maintenance personnel with knowledge of protection against electric shock. Lock the control panel so that only qualified maintenance personnel can operate it.
-

[Disposal Precautions]

CAUTION

- When disposing of this product, treat it as industrial waste.
-

CONDITIONS OF USE FOR THE PRODUCT

(1) Mitsubishi programmable controller ("the PRODUCT") shall be used in conditions;

- i) where any problem, fault or failure occurring in the PRODUCT, if any, shall not lead to any major or serious accident; and
- ii) where the backup and fail-safe function are systematically or automatically provided outside of the PRODUCT for the case of any problem, fault or failure occurring in the PRODUCT.

(2) The PRODUCT has been designed and manufactured for the purpose of being used in general industries.

MITSUBISHI SHALL HAVE NO RESPONSIBILITY OR LIABILITY (INCLUDING, BUT NOT LIMITED TO ANY AND ALL RESPONSIBILITY OR LIABILITY BASED ON CONTRACT, WARRANTY, TORT, PRODUCT LIABILITY) FOR ANY INJURY OR DEATH TO PERSONS OR LOSS OR DAMAGE TO PROPERTY CAUSED BY the PRODUCT THAT ARE OPERATED OR USED IN APPLICATION NOT INTENDED OR EXCLUDED BY INSTRUCTIONS, PRECAUTIONS, OR WARNING CONTAINED IN MITSUBISHI'S USER, INSTRUCTION AND/OR SAFETY MANUALS, TECHNICAL BULLETINS AND GUIDELINES FOR the PRODUCT.

("Prohibited Application")

Prohibited Applications include, but not limited to, the use of the PRODUCT in;

- Nuclear Power Plants and any other power plants operated by Power companies, and/or any other cases in which the public could be affected if any problem or fault occurs in the PRODUCT.
- Railway companies or Public service purposes, and/or any other cases in which establishment of a special quality assurance system is required by the Purchaser or End User.
- Aircraft or Aerospace, Medical applications, Train equipment, transport equipment such as Elevator and Escalator, Incineration and Fuel devices, Vehicles, Manned transportation, Equipment for Recreation and Amusement, and Safety devices, handling of Nuclear or Hazardous Materials or Chemicals, Mining and Drilling, and/or other applications where there is a significant risk of injury to the public or property.

Notwithstanding the above, restrictions Mitsubishi may in its sole discretion, authorize use of the PRODUCT in one or more of the Prohibited Applications, provided that the usage of the PRODUCT is limited only for the specific applications agreed to by Mitsubishi and provided further that no special quality assurance or fail-safe, redundant or other safety features which exceed the general specifications of the PRODUCTS are required. For details, please contact the Mitsubishi representative in your region.

INTRODUCTION

Thank you for purchasing the CC-Link IE Field Network waterproof/dustproof remote I/O module (hereafter abbreviated as I/O module).

This manual describes the procedures, system configuration, parameter settings, functions, and troubleshooting of the I/O module.

Before using this product, please read this manual and the relevant manuals carefully and develop familiarity with the functions and performance of the I/O module to handle the product correctly.

When applying the program examples introduced in this manual to an actual system, ensure the applicability and confirm that it will not cause system control problems.

■ Relevant products

NZ2GF12A4-16D, NZ2GF12A4-16DE, NZ2GF12A2-16T, NZ2GF12A2-16TE, NZ2GF12A42-16DT, NZ2GF12A42-16DTE

Point

Unless otherwise specified, this manual describes the program examples in which the remote I/O signals and remote registers are assigned for an I/O combined module as follows.

- Remote input signal: RX0 to RX7
- Remote output signal: RY8 to RYF
- Remote register: RWr0 to RWrB, RWw0 to RWwB

For the assignment of remote I/O signals and remote registers, refer to the following.

 User's manual for the master/local module used

RELEVANT MANUALS

CC-Link IE Field Network (relevant) manuals

When using the CC-Link IE Field Network for the first time, refer to the CC-Link IE Field Network Master/Local Module User's Manual or Simple Motion Module User's Manual first. The following shows the structure of the CC-Link IE Field Network manuals.

Manual name <manual number>	Description
MELSEC-Q CC-Link IE Field Network Master/Local Module User's Manual <SH-080917ENG>	Overview of the CC-Link IE Field Network, and specifications, procedures before operation, system configuration, installation, wiring, settings, functions, programming, and troubleshooting of the QJ71GF11-T2
MELSEC-L CC-Link IE Field Network Master/Local Module User's Manual <SH-080972ENG>	Overview of the CC-Link IE Field Network, and specifications, procedures before operation, system configuration, installation, wiring, settings, functions, programming, and troubleshooting of the LJ71GF11-T2
MELSEC iQ-R Ethernet/CC-Link IE User's Manual (Startup) <SH-081256ENG>	Specifications, procedures before operation, system configuration, wiring, and communication examples of Ethernet, CC-Link IE Controller Network, and CC-Link IE Field Network
MELSEC iQ-R CC-Link IE Field Network User's Manual (Application) <SH-081259ENG>	Functions, parameter settings, programming, troubleshooting, I/O signals, and buffer memory of CC-Link IE Field Network
MELSEC iQ-R Inter-Module Synchronization Function Reference Manual <SH-081401ENG>	Inter-module synchronization function, which controls multiple modules synchronously
MELSEC-Q QD77GF Simple Motion Module User's Manual (Network) <IB-0300203>	Functions, programming, and troubleshooting for CC-Link IE Field Network of the QD77GF16
MELSEC-Q QD77GF Simple Motion Module User's Manual (Positioning Control) <IB-0300202>	Specifications of the QD77GF16 and information on how to establish a system, maintenance and inspection, and troubleshooting. Functions, programming and buffer memory for the positioning control of the QD77GF16

CONTENTS

COPYRIGHT	1
PRECAUTIONS REGARDING WARRANTY	1
SAFETY PRECAUTIONS	2
CONDITIONS OF USE FOR THE PRODUCT	6
INTRODUCTION	7
RELEVANT MANUALS	8
TERMS	12
CHAPTER 1 PRODUCT LINEUP	13
1.1 I/O Module	13
1.2 Recommended Connector List	14
CHAPTER 2 PART NAMES	16
CHAPTER 3 SPECIFICATIONS	19
3.1 General Specifications	19
3.2 I/O Module Specifications	20
Input module	20
Output module	26
I/O combined module	34
3.3 Function List	44
3.4 List of Remote I/O Signals	46
3.5 List of Remote Register	48
3.6 List of Remote Buffer Memory	50
CHAPTER 4 PROCEDURES BEFORE OPERATION	60
CHAPTER 5 SYSTEM CONFIGURATION	62
5.1 Applicable Systems	62
CHAPTER 6 INSTALLATION AND WIRING	64
6.1 Setting Switch	64
Station number setting with the station number setting switch	64
6.2 Installation Environment and Installation Position	66
Installation environment	66
Installation position	67
Installation direction	67
6.3 Installation	68
Fixing the I/O module	68
6.4 Wiring the Power Supply	68
6.5 Wiring of Ethernet Cable	69
6.6 Attaching Waterproof Caps	71
CHAPTER 7 VARIOUS SETTINGS	72
7.1 Parameter Setting	72
7.2 Changing the Parameter	77
Changing the network configuration	77
Changing the parameter without changing the network configuration	79

CHAPTER 8	FUNCTIONS	81
8.1	Error Notification Function	81
8.2	Input OFF Delay Function	84
8.3	Input Response Time Setting Function	86
8.4	Output HOLD/CLEAR Setting Function	87
8.5	Cyclic Data Update Watch Function	88
8.6	Number of ON Times Integration Function	89
8.7	Output ON/OFF Information Hold Function	91
8.8	Power Supply Monitoring Function	92
8.9	Short-Circuit Detection Function	93
8.10	Fast Logic Function	95
8.11	Initial Operation Setting Function	98
8.12	Protection Function	100
8.13	CC-Link IE Field Network Diagnostic Function	100
CHAPTER 9	PROGRAMMING	103
9.1	Precautions for Programming	103
9.2	Procedure for Programming	104
9.3	Program Example	104
9.4	Program Example for the Number of ON Times Integration Function	111
	Program example for checking the number of ON times	111
	Program example for clearing the number of ON times	111
9.5	Program Example for the Fast Logic Function	114
	Program example for the fast logic function	114
	Program example for checking the fast logic enable or disable status	117
CHAPTER 10	MAINTENANCE AND INSPECTION	119
CHAPTER 11	TROUBLESHOOTING	121
11.1	Checking for the Error Codes and the Warning Codes	121
11.2	Error Code List	124
11.3	Checking the LEDs	128
11.4	Unit Test	131
11.5	Troubleshooting for Each Phenomenon	132
11.6	Examples of Troubles with the I/O Module	134
	Troubleshooting for input circuit	134
	Troubleshooting for output circuit	137
APPENDICES		143
Appendix 1	Details of Remote I/O Signals	143
	Remote input signal	143
	Remote output signal	143
Appendix 2	Details of Remote Registers	144
Appendix 3	Details of Remote Buffer Memory Addresses	154
Appendix 4	EMC and Low Voltage Directives	166
	Measures to comply with the EMC Directive	166
	Requirements to compliance with the Low Voltage Directive	168
Appendix 5	How to Check Serial Number and Function Version	169
Appendix 6	External Dimensions	170





INDEX

172

REVISIONS	174
WARRANTY	175
TRADEMARKS	176

TERMS

Unless otherwise specified, this manual uses the following terms.

Term	Description
Buffer memory	A memory in an intelligent function module, where data (such as setting values and monitoring values) exchanged with a CPU module are stored
CC-Link IE Field Network	A high-speed and large-capacity open field network that is based on Ethernet (1000BASE-T)
Cyclic transmission	A function by which data are periodically exchanged among stations on the same network using link devices (RX, RY, RWw, and RWr)
Data link	A generic term for cyclic transmission and transient transmission
Dedicated instruction	An instruction that simplifies programming for using functions of intelligent function modules
Disconnection	A process of stopping data link if a data link error occurs
Engineering tool	A generic term for GX Works2 and GX Works3
GX Works2	The product name of the software package for the MELSEC programmable controllers
GX Works3	
I/O combined module	A generic term for modules where a digital signal can be input and output
I/O module	The abbreviation for the CC-Link IE Field Network remote I/O module
Input module	A generic term for modules where a digital signal can be input
Intelligent device station	A station that exchanges I/O signals (bit data) and I/O data (word data) with another station by cyclic transmission. This station can perform transient transmission as well. This station responds to a transient transmission request from another station and also issues a transient transmission request to another station.
Link device	A device (RX, RY, RWr, or RWw) in a module on CC-Link IE Field Network
Link special register (SW)	Word data that indicates the operating status and data link status of a module on CC-Link IE Field Network
Link special relay (SB)	Bit data that indicates the operating status and data link status of a module on CC-Link IE Field Network
Local station	A station that performs cyclic transmission and transient transmission with the master station and other local stations. The station is controlled by programs in the CPU module or other equivalent modules on the station.
Master station	A station that controls the entire network. This station can perform cyclic transmission and transient transmission with all stations. Only one master station can be used in a network.
Master/local module	The abbreviation for the CC-Link IE Field Network master/local module
Output module	A generic term for modules where a digital signal can be output
REMFR	The abbreviation for ZP.REMFR.
Remote buffer memory	Buffer memory in a remote device station and intelligent device station
Remote device station	A station that exchanges I/O signals (bit data) and I/O data (word data) with another station by cyclic transmission. This station responds to a transient transmission request from another station.
Remote I/O station	A station that exchanges I/O signals (bit data) with the master station by cyclic transmission
Remote input (RX)	Bit data input from a slave station to the master station (For some areas in a local station, data are input in the opposite direction.)  User's manual for the master/local module used
Remote output (RY)	Bit data output from the master station to a slave station (For some areas in a local station, data are output in the opposite direction.)  User's manual for the master/local module used
Remote register (RWr)	Word data input from a slave station to the master station (For some areas in a local station, data are input in the opposite direction.)  User's manual for the master/local module used
Remote register (RWw)	Word data output from the master station to a slave station (For some areas in a local station, data are output in the opposite direction.)  User's manual for the master/local module used
REMTO	The abbreviation for ZP.REMTO.
Reserved station	A station reserved for future use. This station is not actually connected, but counted as a connected station
Simple motion module	The abbreviation for the QD77GF16 simple motion module
Slave station	A generic term for stations other than a master station: local station, remote I/O station, remote device station, and intelligent device station
Transient transmission	A function of communication with another station, which is used when requested by a dedicated instruction or an engineering tool

1 PRODUCT LINEUP

1.1 I/O Module

Input module

■DC input module

The following table lists applicable DC input modules.

Input type	Input specifications	Module power supply current	Weight	Model	Reference
Positive common type	Waterproof connector 24VDC, 16 points	300mA	0.72kg	NZ2GF12A4-16D	Page 20 NZ2GF12A4-16D DC input module
Negative common type	Waterproof connector 24VDC, 16 points	220mA	0.71kg	NZ2GF12A4-16DE	Page 23 NZ2GF12A4-16DE DC input module

Output module

■Transistor output module

The following table lists applicable transistor output modules.

Output type	Output specifications	Module power supply current	Weight	Model	Reference
Sink type	Waterproof connector 12 to 24VDC, 2A/1 point, 16 points	240mA	0.71kg	NZ2GF12A2-16T	Page 26 NZ2GF12A2-16T transistor output module
Source type	Waterproof connector 12 to 24VDC, 2A/1 point, 16 points	230mA	0.70kg	NZ2GF12A2-16TE	Page 30 NZ2GF12A2-16TE transistor output module

I/O combined module

■DC input/transistor output module

The following table lists applicable DC input/transistor output modules.

Type	Specifications	Module power supply current	Weight	Model	Reference
Input part	Positive common type Waterproof connector 24VDC, 8 points	240mA	0.72kg	NZ2GF12A42-16DT	Page 34 NZ2GF12A42-16DT DC input transistor output module
Output part	Sink type Waterproof connector 12 to 24VDC, 2A/1 point, 8 points				
Input part	Negative common type Waterproof connector 24VDC, 8 points	230mA	0.72kg	NZ2GF12A42-16DTE	Page 39 NZ2GF12A42-16DTE DC input transistor output module
Output part	Source type Waterproof connector 12 to 24VDC, 2A/1 point, 8 points				

1.2 Recommended Connector List

The following table lists applicable waterproof connectors.

Ex.

□ of a model name indicates a numerical value representing the length of each cable.

For details on applicable waterproof connectors, refer to the website of each manufacturer.

For power supply

The following table lists applicable waterproof connectors for power supply.

Type		Model	Connection cable diameter	Manufacturer
Connector	Cable			
7/8" 5 pins Male (OUT)	—	1A5006-34	φ5.08 to 11.43mm	Molex, LLC
7/8" 5 pins Female (IN)		1A5000-34		
7/8" 5 pins Male (OUT)		105006K13M□	—	
7/8" 5 pins Female (IN)		105000K13M□		
7/8" 5 pins Male (OUT)- Female (IN)		115030K13M□		

*1 4 pins do not include the FG pin.

For I/O

The following table lists applicable waterproof connectors for I/O.

Type		Model	Connection cable diameter	Manufacturer
Connector	Cable			
M12 4 pins*1 Male (one-touch)	A code	WA4006-31	φ3.3 to 6.6mm	Molex, LLC
		WA4006-32	φ4.1 to 8.1mm	
		W04006E03M□, 8W4030E03M□	—	
M12 4 pins*1 Male (screw)		8A4006-31	φ3.3 to 6.6mm	
		8A4006-32	φ4.1 to 8.1mm	
		804006J11M□, 884030J11M□	—	
M12 5 pins Male (one-touch)		WA5006-31	φ3.3 to 6.6mm	
		WA5006-32	φ4.1 to 8.1mm	
		W05006E03M□, 8W5030E03M□	—	
M12 5 pins Male (screw)	8A5006-31	φ3.3 to 6.6mm		
	8A5006-32	φ4.1 to 8.1mm		
	805006J06M□, 885030J06M□	—		

*1 4 pins do not include the FG pin.

Y-branch connector for I/O

The following table lists applicable Y-branch connectors for I/O.

Type		Model	Connection cable diameter	Manufacturer
Connector	Cable			
M12 4 pins*1 Male	A code	81590R, 81589R, 884045J11M□, 8W4A30E03M003	—	Molex, LLC
M12 5 pins Male		0812-05EMF-00001		

*1 4 pins do not include the FG pin.

For communications

The following table lists applicable waterproof connectors for communications.

Type		Model	Connection cable diameter	Manufacturer
Connector	Cable			
M12 8 pins Male	X code-X code	E22E06020M□	—	Molex, LLC
M12 8 pins Male	X code-RJ45	E26E06020M□		
M12 8 pins Male	—	J80026A0100	φ5.5 to 9.0mm	Telegartner Karl Gartner GmbH
M12 8 pins Male	—	IE-PS-M12X-P-AWG22/27FH	φ5.5 to 9.0mm	Weidmueller Interface GmbH & Co. KG
—	Cable only	SC-E5EW-□M	—	Mitsubishi Electric System & Service Co., Ltd.

Waterproof cap

The following table lists applicable waterproof caps.

Type		Model	Connection cable diameter	Manufacturer
Connector	Cable			
M12	—	120358-0007	—	Molex, LLC
7/8" Male (OUT)	—	65-0085	—	
7/8" Female (IN)	—	65-0086	—	

2 PART NAMES

Part names of an I/O module

This section describes part names of the I/O module.

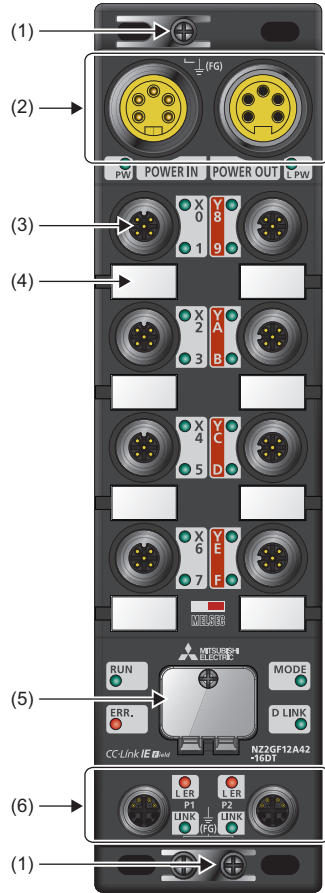

No.	Name	Application
(1)	FG metal fitting	Metal fitting for connecting FG For the tightening torque of screws for the FG metal fitting, refer to the following. ☞ Page 68 Fixing the I/O module
(2)	Power supply connectors	Connectors for the module-and-sensor power supply (24VDC) and load power supply (24VDC)
(3)	I/O connector	Connector for I/O signals
(4)	Signal label	Label for describing signal names
(5)	Station number setting switch	Rotary switch for setting a station number or tests ☞ Page 64 Setting Switch ☞ Page 131 Unit Test
(6)	Communication connectors	P1 PORT1 connector for CC-Link IE Field Network Connect an Ethernet cable. (☞ Page 69 Wiring of Ethernet Cable)
		P2 PORT2 connector for CC-Link IE Field Network Connect an Ethernet cable. (☞ Page 69 Wiring of Ethernet Cable)

LEDs on an I/O module

This section describes LEDs on an I/O module.

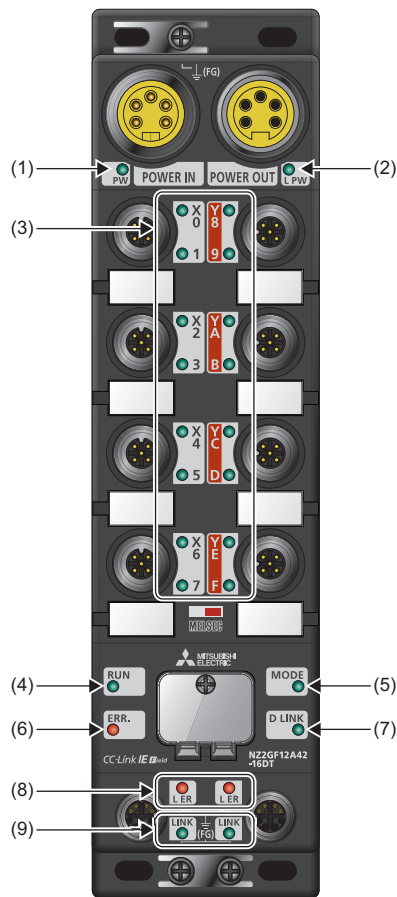

No.	Name	Description
(1)	PW LED	Indicates the voltage status of the module power supply. Green: The module power supply has no voltage error. Red: The module power supply has a voltage error. Off: The module power supply is off or has a voltage error.
(2)	L PW LED	Indicates the voltage status of the load power supply. Green: The load power supply has no voltage error. Red: The load power supply has a voltage error. Off: The load power supply is off or has a voltage error. The NZ2GF12A4-16D and NZ2GF12A4-16DE have no L PW LED.
(3)	I/O LED	Indicates the on/off state of I/Os. Green: I/O is on. Red: Error (short-circuit detection or power supply error) Off: I/O is off. For details on the short-circuit detection, refer to the following. ☞ Page 93 Short-Circuit Detection Function
(4)	RUN LED	Indicates the operating status of the I/O module. On: Operating normally. Off: Error
(5)	MODE LED	Indicates the mode of the I/O module. On: Online Flashing: Unit test mode Off: The unit test is completed.
(6)	ERR. LED	Indicates the error status of the I/O module. On: A module error has occurred. Flashing: A minor error has occurred. Off: Operating normally.

No.	Name	Description
(7)	D LINK LED	Indicates the data link status of the I/O module. On: Data link in operation (cyclic transmission in progress) Flashing: Data link in operation (cyclic transmission stopped) Off: Data link not performed
(8)	L ER LED	Indicates the status of each port. On: Module received abnormal data, or module performing loopback Off: Module received normal data, or module not performing loopback
(9)	LINK LED ^{*1}	Indicates the link status. On: Linkup in progress Off: Linkdown in progress

*1 The LINK LED may turn on when the module is powered on. This behavior does not indicate an error.

I/O module status and LED status

The following table lists the correspondence between the I/O module status and the LED status.

I/O module status		Data link status	LED status				
			PW LED	RUN LED	MODE LED	ERR. LED	D LINK LED
Disconnected		Disconnection	On	On	On	Off	Off
Data link in operation		Data link in operation	On	On	On	Off	On
Reserved station setting in progress		Cyclic stop	On	On	On	Off	Flashing
Data link stop		Cyclic stop	On	On	On	Off	Flashing
Unit test	In progress	—	On	On	Flashing	Off	Off
	Normal completion	—	On	On	Off	Off	Off
	Abnormal completion	—	On	On	Off	On	Off
Communication error		Cyclic stop	On	On	On	Off	Flashing
Error	Major error	—	On	Off	*1	On ^{*3}	*2
	Moderate error	—	On	On	*1	On	*2
Warning	Minor error	—	On	On	*1	Flashing	*2
Power supply voltage error detection		—	On ^{*4}	On	On	On	On

*1 Either of On or Off.

*2 Either of On, Flashing, or Off.

*3 When the module is failed, the LED may not turn on.

*4 When a power supply voltage error is detected, the LED turns on in red. (When the module is in the status other than that, the LED turns on in green.)

3 SPECIFICATIONS

This chapter describes the specifications of the I/O module.

3.1 General Specifications

Item	Specifications					
Operating ambient temperature	0 to 55°C					
Storage ambient temperature	-25 to 75°C					
Operating ambient humidity	Conforming to IP67*1					
Storage ambient humidity	5 to 95%RH, non-condensing					
Vibration resistance	Compliant with JIS B 3502 and IEC 61131-2		Frequency	Constant acceleration	Half amplitude	Number of sweeps
		Under intermittent vibration	5 to 8.4Hz	—	3.5mm	10 times each in X, Y, and Z directions
			8.4 to 150Hz	9.8m/s ²	—	
		Under continuous vibration	5 to 8.4Hz	—	1.75mm	
8.4 to 150Hz	4.9m/s ²		—			
Shock resistance	Compliant with JIS B 3502 and IEC 61131-2 (147m/s ² , 3 times each in X, Y, and Z directions)					
Operating atmosphere	No corrosive gases					
Operating altitude*2	0 to 2000m					
Installation location	Inside/outside a control panel					
Overvoltage category*3	II or less					
Pollution degree*4	2 or less					
Equipment class	Class I					

*1 Only when all necessary waterproof connectors and caps have been installed and the station number setting switch cover has been properly tightened with a screw, the module conforms to IP67. For the tightening torque range of the screw for the station number setting switch cover, refer to the following.

 Page 65 Tightening torque

*2 Do not use or store the I/O module under pressure higher than the atmospheric pressure of altitude 0m. Doing so may cause malfunction. When using the I/O module under pressure, please consult your local Mitsubishi representative.

*3 This indicates the section of the power supply to which the equipment is assumed to be connected between the public electrical power distribution network and the machinery within premises.

Category II applies to equipment for which electrical power is supplied from fixed facilities. The surge voltage withstand level for the equipment with the rated voltage of 300V or less is 2500V.

*4 This index indicates the degree to which conductive material is generated in terms of the environment in which the equipment is used. Pollution degree 2 is when only non-conductive pollution occurs. A temporary conductivity caused by condensing must be expected occasionally.

Point

To use the I/O module complying with the EMC Directive, refer to "EMC and Low Voltage Directives" in this manual. ( Page 166 EMC and Low Voltage Directives)

3.2 I/O Module Specifications

Input module

NZ2GF12A4-16D DC input module

Item	NZ2GF12A4-16D	
Station type	Remote device station	
Number of input points	16 points	
Rated input voltage	24VDC (ripple rate: 5% or less) (Allowable voltage range: 20.4 to 28.8VDC)	
Rated input current	7mA TYP. (for 24VDC)	
Isolation method	Non-isolation	
Max. number of simultaneous input points	100%	
ON voltage/ON current	15VDC or more/3.5mA or more	
OFF voltage/OFF current	8VDC or less/1.7mA or less	
Input resistance	3.3kΩ	
Input response time	OFF → ON	0ms/0.5ms/1ms/1.5ms/5ms/10ms/20ms/70ms
	ON → OFF	(Initial setting: 10ms)
Input type	Positive common (sink type)	
Withstand voltage	500VAC for 1 minute between all DC external terminals and the ground	
Insulation resistance	10MΩ or higher between all DC external terminals and ground (500VDC insulation resistance tester)	
Protection degree	IP67	
Wiring method for common	16 points/common (2- to 4-wire, waterproof connector type)	
External interface	Module power supply part	7/8" waterproof connector, 5 pins, male (IN)/female (OUT)
	I/O part	M12 waterproof connector, 5 pins, female, A-code
	Communication part	M12 waterproof connector, 8 pins, female, X-code
Applicable waterproof connector	For power supply	☞ Page 14 Recommended Connector List
	For I/O	
	Y-branch connector for I/O	
	For communications	
Cyclic transmission	RX/RY points	16 points
	RWr/RWw points	12 points
Communication cable	An Ethernet cable that meets the 1000BASE-T standard: Category 5e or higher (double shielded, STP), straight cable	
Module power supply	Voltage	24VDC (ripple rate: 5% or less) (Allowable voltage range: 20.4 to 28.8VDC)
	Current	300mA or less (24VDC, all points ON)
Short-circuit detection current of sensor power supply	400mA or more/input connector	
Weight	0.72kg	

Point

The processing time of the remote device station (input) is the time period for internal processing of the remote device station (input). The value of the processing time of the remote device station (input) is used in the calculation for the delay time of the cyclic transmission from the remote device station (input) to the master station (RX/RWr). Calculate the processing time of the remote device station (input) by the following formula.

- The processing time of the remote device station (input) = The input response time + The internal processing time (0.2ms)

For the delay time of the cyclic transmission from the remote device station (input) to the master station (RX/RWr), refer to the following.

☞ User's manual for the master/local module used

External connection

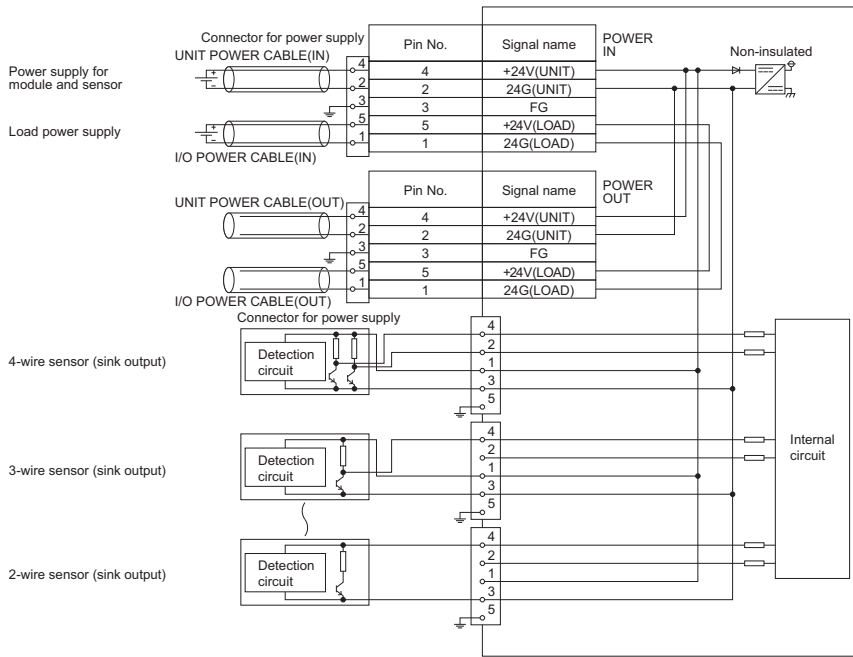

3

Power supply connectors

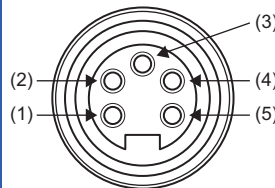
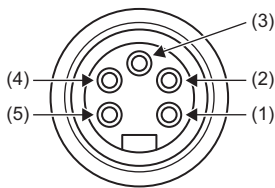

Pin number	Signal name	Pin number	Signal name		
7/8" connector Male (IN)	(1)	24G (LOAD)	7/8" connector Female (OUT)	(1)	24G (LOAD)
	(2)	24G (UNIT)		(2)	24G (UNIT)
	(3)	FG		(3)	FG
	(4)	+24V (UNIT)		(4)	+24V (UNIT)
	(5)	+24V (LOAD)		(5)	+24V (LOAD)

I/O connectors

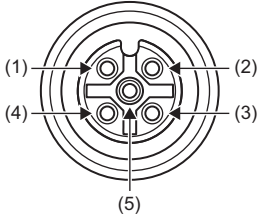

Pin number		Signal name	Pin number		Signal name
X0 X1	(1)	+24V (UNIT)	X8 X9	(1)	+24V (UNIT)
	(2)	X1		(2)	X9
	(3)	24G (UNIT)		(3)	24G (UNIT)
	(4)	X0		(4)	X8
	(5)	FG		(5)	FG
X2 X3	(1)	+24V (UNIT)	XA XB	(1)	+24V (UNIT)
	(2)	X3		(2)	XB
	(3)	24G (UNIT)		(3)	24G (UNIT)
	(4)	X2		(4)	XA
	(5)	FG		(5)	FG
X4 X5	(1)	+24V (UNIT)	XC XD	(1)	+24V (UNIT)
	(2)	X5		(2)	XD
	(3)	24G (UNIT)		(3)	24G (UNIT)
	(4)	X4		(4)	XC
	(5)	FG		(5)	FG
X6 X7	(1)	+24V (UNIT)	XE XF	(1)	+24V (UNIT)
	(2)	X7		(2)	XF
	(3)	24G (UNIT)		(3)	24G (UNIT)
	(4)	X6		(4)	XE
	(5)	FG		(5)	FG

NZ2GF12A4-16DE DC input module

Item		NZ2GF12A4-16DE
Station type		Remote device station
Number of input points		16 points
Rated input voltage		24VDC (ripple rate: 5% or less) (Allowable voltage range: 20.4 to 28.8VDC)
Rated input current		7mA TYP. (for 24VDC)
Isolation method		Non-isolation
Max. number of simultaneous input points		100%
ON voltage/ON current		15VDC or more/3.5mA or more
OFF voltage/OFF current		8VDC or less/1.7mA or less
Input resistance		3.3k Ω
Input response time	OFF \rightarrow ON	0ms/0.5ms/1ms/1.5ms/5ms/10ms/20ms/70ms (Initial setting: 10ms)
	ON \rightarrow OFF	
Input type		Negative common (source type)
Withstand voltage		500VAC for 1 minute between all DC external terminals and the ground
Insulation resistance		10M Ω or higher between all DC external terminals and ground (500VDC insulation resistance tester)
Protection degree		IP67
Wiring method for common		16 points/common (2- to 4-wire, waterproof connector type)
External interface	Module power supply part	7/8" waterproof connector, 5 pins, male (IN)/female (OUT)
	I/O part	M12 waterproof connector, 5 pins, female, A-code
	Communication part	M12 waterproof connector, 8 pins, female, X-code
Applicable waterproof connector	For power supply	 Page 14 Recommended Connector List
	For I/O	
	Y-branch connector for I/O	
	For communications	
Cyclic transmission	RX/RY points	16 points
	RWr/RWw points	12 points
Communication cable		An Ethernet cable that meets the 1000BASE-T standard: Category 5e or higher (double shielded, STP), straight cable
Module power supply	Voltage	24VDC (ripple rate: 5% or less) (Allowable voltage range: 20.4 to 28.8VDC)
	Current	220mA or less (24VDC, all points ON)
Short-circuit detection current of sensor power supply		400mA or more/input connector
Weight		0.71kg

External connection

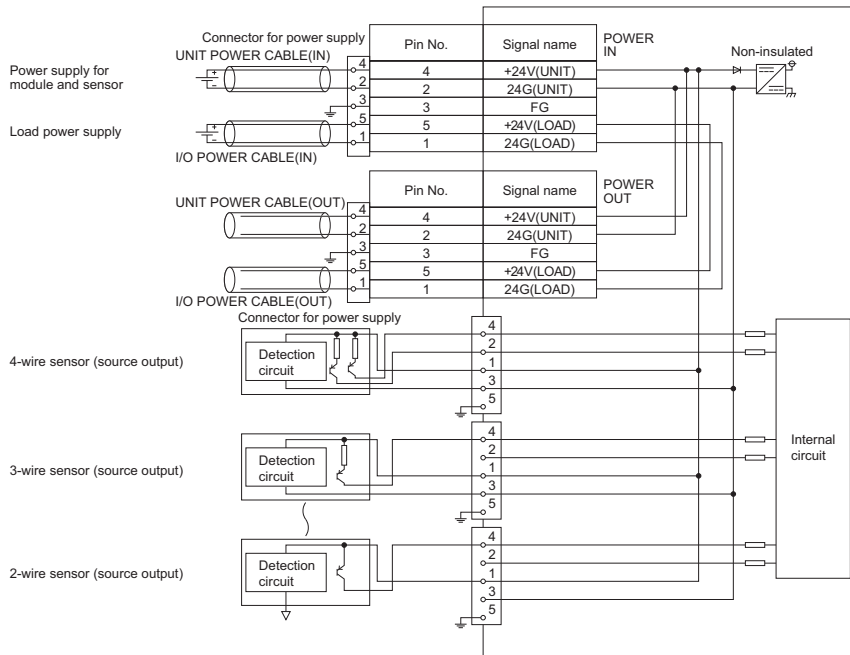

Power supply connectors

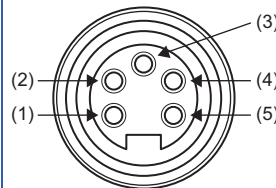
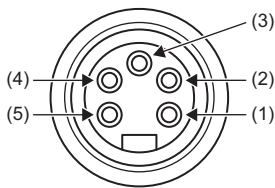

Pin number	Signal name	Pin number	Signal name		
7/8" connector Male (IN)	(1)	24G (LOAD)	7/8" connector Female (OUT)	(1)	24G (LOAD)
	(2)	24G (UNIT)		(2)	24G (UNIT)
	(3)	FG		(3)	FG
	(4)	+24V (UNIT)		(4)	+24V (UNIT)
	(5)	+24V (LOAD)		(5)	+24V (LOAD)

I/O connectors

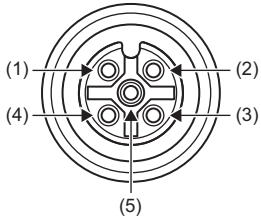

Pin number		Signal name	Pin number		Signal name
X0 X1	(1)	+24V (UNIT)	X8 X9	(1)	+24V (UNIT)
	(2)	X1		(2)	X9
	(3)	24G (UNIT)		(3)	24G (UNIT)
	(4)	X0		(4)	X8
	(5)	FG		(5)	FG
X2 X3	(1)	+24V (UNIT)	XA XB	(1)	+24V (UNIT)
	(2)	X3		(2)	XB
	(3)	24G (UNIT)		(3)	24G (UNIT)
	(4)	X2		(4)	XA
	(5)	FG		(5)	FG
X4 X5	(1)	+24V (UNIT)	XC XD	(1)	+24V (UNIT)
	(2)	X5		(2)	XD
	(3)	24G (UNIT)		(3)	24G (UNIT)
	(4)	X4		(4)	XC
	(5)	FG		(5)	FG
X6 X7	(1)	+24V (UNIT)	XE XF	(1)	+24V (UNIT)
	(2)	X7		(2)	XF
	(3)	24G (UNIT)		(3)	24G (UNIT)
	(4)	X6		(4)	XE
	(5)	FG		(5)	FG

Output module

NZ2GF12A2-16T transistor output module

Item		NZ2GF12A2-16T
Station type		Remote device station
Number of output points		16 points
Rated load voltage		12/24VDC (ripple rate: 5% or less) (Allowable voltage range: 10.2 to 28.8VDC)
Max. load current		2A/point, 8A/common
Isolation method		Digital isolator isolation
Max. inrush current		Current is limited by the overload protection function.
Leakage current at OFF		0.1mA or less
Max. voltage drop at ON		0.3VDC (TYP.) 0.5A, 0.6VDC (MAX.) 0.5A
Output response time	OFF → ON	0.5ms or less
	ON → OFF	1.5ms or less (resistance load)
Surge suppressor		Zener diode
Output type		Sink type
Withstand voltage		500VAC for 1 minute between all DC external terminals and the ground
Insulation resistance		10MΩ or higher between all DC external terminals and ground (500VDC insulation resistance tester)
Protection degree		IP67
Wiring method for common		16 points/common (2-wire, waterproof connector type)
Protection function	Overload protection function	Limited current when detecting overcurrent: 6.5A or more/point Activated to each point.
	Overheat protection function	Activated to each point.
External interface	Module power supply part	7/8" waterproof connector, 5 pins, male (IN)/female (OUT)
	I/O part	M12 waterproof connector, 5 pins, female, A-code
	Communication part	M12 waterproof connector, 8 pins, female, X-code
Applicable waterproof connector	For power supply	 Page 14 Recommended Connector List
	For I/O	
	Y-branch connector for I/O	
	For communications	
Cyclic transmission	RX/RY points	16 points
	RWr/RWw points	12 points
Communication cable		An Ethernet cable that meets the 1000BASE-T standard: Category 5e or higher (double shielded, STP), straight cable
Module power supply	Voltage	24VDC (ripple rate: 5% or less) (Allowable voltage range: 20.4 to 28.8VDC)
	Current	240mA or less (24VDC, all points ON)
Short-circuit detection current		6.5A or more/point
Weight		0.71kg

Point

The processing time of the remote device station (output) is the time period for internal processing of the remote device station (output). The value of the processing time of the remote device station (output) is used in the calculation for the delay time of the cyclic transmission from the master station (RY/RWw) to the remote device station (output). Calculate the processing time of the remote device station (output) by the following formula.

- The processing time of the remote device station (output) = The output response time (1.5ms) + The internal processing time (0.2ms) = 1.7ms

For the delay time of the cyclic transmission from the master station (RY/RWw) to the remote device station (output), refer to the following.

 User's manual for the master/local module used

External connection

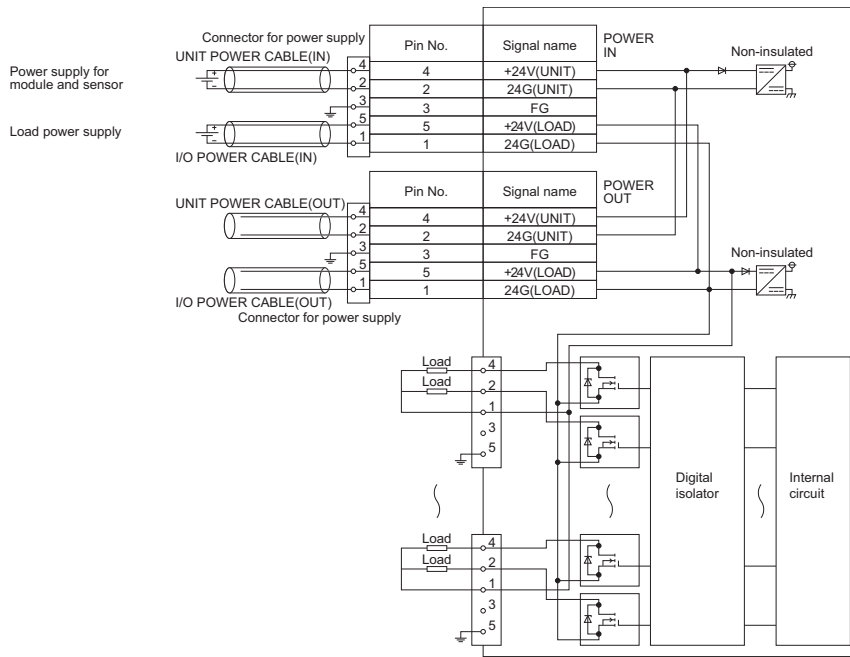

Power supply connectors

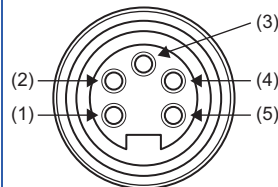
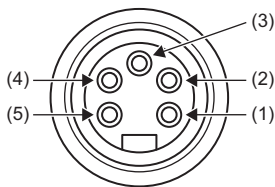

Pin number	Signal name	Pin number	Signal name		
7/8" connector Male (IN)	(1)	24G (LOAD)	7/8" connector Female (OUT)	(1)	24G (LOAD)
	(2)	24G (UNIT)		(2)	24G (UNIT)
	(3)	FG		(3)	FG
	(4)	+24V (UNIT)		(4)	+24V (UNIT)
	(5)	+24V (LOAD)		(5)	+24V (LOAD)

I/O connectors

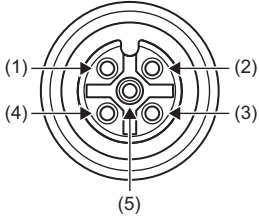

Pin number		Signal name	Pin number		Signal name
Y0 Y1	(1)	+24V (LOAD)	Y8 Y9	(1)	+24V (LOAD)
	(2)	Y1		(2)	Y9
	(3)	Empty		(3)	Empty
	(4)	Y0		(4)	Y8
	(5)	FG		(5)	FG
Y2 Y3	(1)	+24V (LOAD)	YA YB	(1)	+24V (LOAD)
	(2)	Y3		(2)	YB
	(3)	Empty		(3)	Empty
	(4)	Y2		(4)	YA
	(5)	FG		(5)	FG
Y4 Y5	(1)	+24V (LOAD)	YC YD	(1)	+24V (LOAD)
	(2)	Y5		(2)	YD
	(3)	Empty		(3)	Empty
	(4)	Y4		(4)	YC
	(5)	FG		(5)	FG
Y6 Y7	(1)	+24V (LOAD)	YE YF	(1)	+24V (LOAD)
	(2)	Y7		(2)	YF
	(3)	Empty		(3)	Empty
	(4)	Y6		(4)	YE
	(5)	FG		(5)	FG

Derating chart

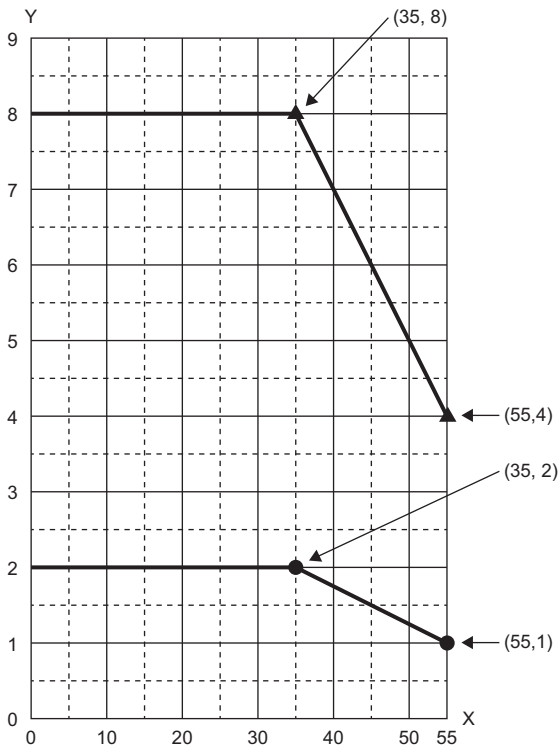

X: Ambient temperature (°C)

Y: Output current (A)

●: Output current per point

▲: Output current per common

NZ2GF12A2-16TE transistor output module

Item		NZ2GF12A2-16TE
Station type		Remote device station
Number of output points		16 points
Rated load voltage		12/24VDC (ripple rate: 5% or less) (Allowable voltage range: 10.2 to 28.8VDC)
Max. load current		2A/point, 8A/common
Isolation method		Digital isolator isolation
Max. inrush current		Current is limited by the overload protection function.
Leakage current at OFF		0.1mA or less
Max. voltage drop at ON		0.5VDC (TYP.) 0.5A, 0.8VDC (MAX.) 0.5A
Output response time	OFF → ON	0.5ms or less
	ON → OFF	1.5ms or less (resistance load)
Surge suppressor		Zener diode
Output type		Source type
Withstand voltage		500VAC for 1 minute between all DC external terminals and the ground
Insulation resistance		10MΩ or higher between all DC external terminals and ground (500VDC insulation resistance tester)
Protection degree		IP67
Wiring method for common		16 points/common (2-wire, waterproof connector type)
Protection function	Overload protection function	Limited current when detecting overcurrent: 6.5A or more/point Activated to each point.
	Overheat protection function	Activated to each point.
External interface	Module power supply part	7/8" waterproof connector, 5 pins, male (IN)/female (OUT)
	I/O part	M12 waterproof connector, 5 pins, female, A-code
	Communication part	M12 waterproof connector, 8 pins, female, X-code
Applicable waterproof connector	For power supply	☞ Page 14 Recommended Connector List
	For I/O	
	Y-branch connector for I/O	
	For communications	
Cyclic transmission	RX/RY points	16 points
	RWr/RWw points	12 points
Communication cable		An Ethernet cable that meets the 1000BASE-T standard: Category 5e or higher (double shielded, STP), straight cable
Module power supply	Voltage	24VDC (ripple rate: 5% or less) (Allowable voltage range: 20.4 to 28.8VDC)
	Current	230mA or less (24VDC, all points ON)
Short-circuit detection current		6.5A or more/point
Weight		0.70kg

External connection

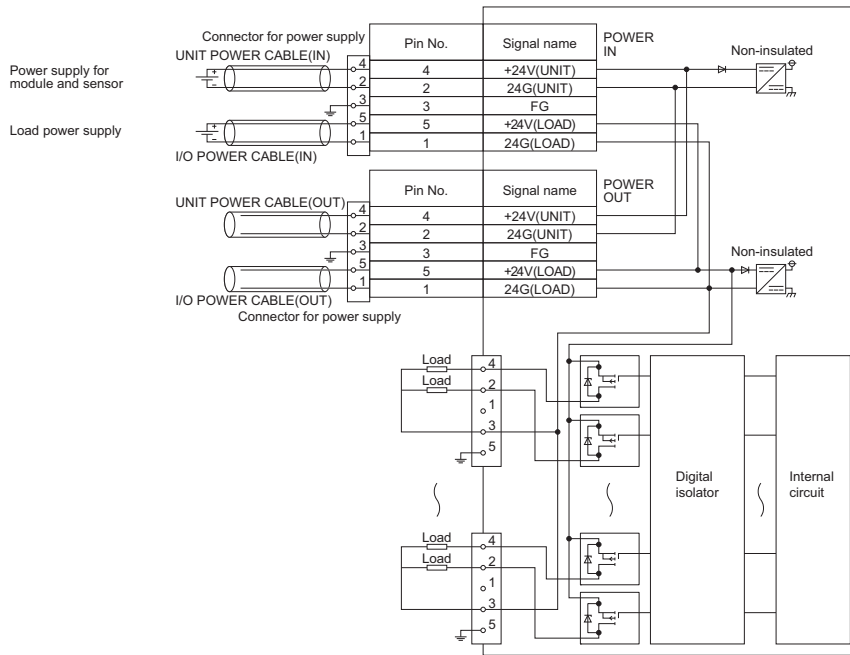

Power supply connectors

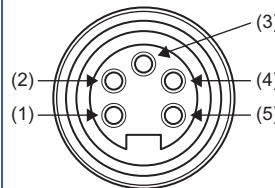
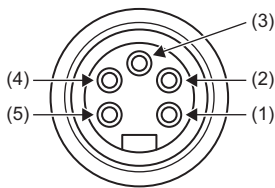

Pin number	Signal name	Pin number	Signal name		
7/8" connector Male (IN)	(1)	24G (LOAD)	7/8" connector Female (OUT)	(1)	24G (LOAD)
	(2)	24G (UNIT)		(2)	24G (UNIT)
	(3)	FG		(3)	FG
	(4)	+24V (UNIT)		(4)	+24V (UNIT)
	(5)	+24V (LOAD)		(5)	+24V (LOAD)

I/O connectors

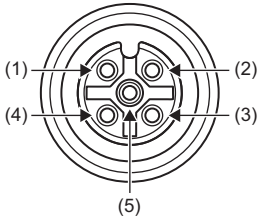

Pin number		Signal name	Pin number		Signal name
Y0 Y1	(1)	Empty	Y8 Y9	(1)	Empty
	(2)	Y1		(2)	Y9
	(3)	24G (LOAD)		(3)	24G (LOAD)
	(4)	Y0		(4)	Y8
	(5)	FG		(5)	FG
Y2 Y3	(1)	Empty	YA YB	(1)	Empty
	(2)	Y3		(2)	YB
	(3)	24G (LOAD)		(3)	24G (LOAD)
	(4)	Y2		(4)	YA
	(5)	FG		(5)	FG
Y4 Y5	(1)	Empty	YC YD	(1)	Empty
	(2)	Y5		(2)	YD
	(3)	24G (LOAD)		(3)	24G (LOAD)
	(4)	Y4		(4)	YC
	(5)	FG		(5)	FG
Y6 Y7	(1)	Empty	YE YF	(1)	Empty
	(2)	Y7		(2)	YF
	(3)	24G (LOAD)		(3)	24G (LOAD)
	(4)	Y6		(4)	YE
	(5)	FG		(5)	FG

Derating chart

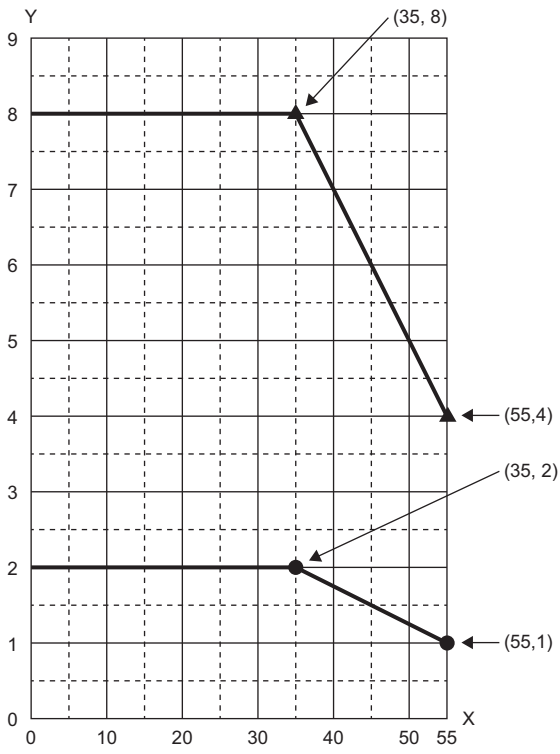

X: Ambient temperature (°C)

Y: Output current (A)

●: Output current per point

▲: Output current per common

I/O combined module

NZ2GF12A42-16DT DC input transistor output module

Item	NZ2GF12A42-16DT		
	Input specifications	Output specifications	
Station type	Remote device station		
Number of input points	8 points	—	
Rated input voltage	24VDC (ripple rate: 5% or less) (Allowable voltage range: 20.4 to 28.8VDC)		
Rated input current	7mA TYP. (for 24VDC)		
Isolation method	Non-isolation		
Max. number of simultaneous input points	100%		
ON voltage/ON current	15VDC or more/3.5mA or more		
OFF voltage/OFF current	8VDC or less/1.7mA or less		
Input resistance	3.3kΩ		
Input response time *1	OFF → ON		0ms/0.5ms/1ms/1.5ms/5ms/10ms/20ms/70ms (Initial setting: 10ms)
	ON → OFF		
Input type	Positive common (sink type)		
Short-circuit detection current of sensor power supply	400mA or more/input connector	—	
Number of output points	—	8 points	
Rated load voltage		12/24VDC (ripple rate: 5% or less) (Allowable voltage range: 10.2 to 28.8VDC)	
Max. load current		2A/point, 8A/common	
Isolation method		Digital isolator isolation	
Max. inrush current		Current is limited by the overload protection function.	
Leakage current at OFF		0.1mA or less	
Max. voltage drop at ON		0.3VDC (TYP.) 0.5A, 0.6VDC (MAX.) 0.5A	
Output response time *2	OFF → ON	0.5ms or less	
	ON → OFF	1.5ms or less (resistance load)	
Surge suppressor		Zener diode	
Output type		Sink type	
Protection function	Overload protection function	Limited current when detecting overcurrent: 6.5A or more/point Activated to each point.	
	Overheat protection function	Activated to each point.	
Short-circuit detection current	—	6.5A or more/point	
Withstand voltage	500VAC for 1 minute between all DC external terminals and the ground		
Insulation resistance	10MΩ or higher between all DC external terminals and ground (500VDC insulation resistance tester)		
Protection degree	IP67		
Wiring method for common	8 points/common (2- to 4-wire, waterproof connector type)	8 points/common (2-wire, waterproof connector type)	
External interface	Module power supply part	7/8" waterproof connector, 5 pins, male (IN)/female (OUT)	
	I/O part	M12 waterproof connector, 5 pins, female, A-code	
	Communication part	M12 waterproof connector, 8 pins, female, X-code	
Applicable waterproof connector	For power supply	☞ Page 14 Recommended Connector List	
	For I/O		
	Y-branch connector for I/O		
	For communications		
Cyclic transmission	RX/RY points	16 points	
	RWr/RWw points	12 points	

Item		NZ2GF12A42-16DT	
		Input specifications	Output specifications
Communication cable		An Ethernet cable that meets the 1000BASE-T standard: Category 5e or higher (double shielded, STP), straight cable	
Module power supply	Voltage	24VDC (ripple rate: 5% or less) (Allowable voltage range: 20.4 to 28.8VDC)	
	Current	240mA or less (24VDC, all points ON)	
Weight		0.72kg	

*1 For how to calculate the processing time of the remote device station (input), refer to the point in the following.

☞ Page 20 NZ2GF12A4-16D DC input module

*2 For how to calculate the processing time of the remote device station (output), refer to the point in the following.

☞ Page 26 NZ2GF12A2-16T transistor output module

External connection

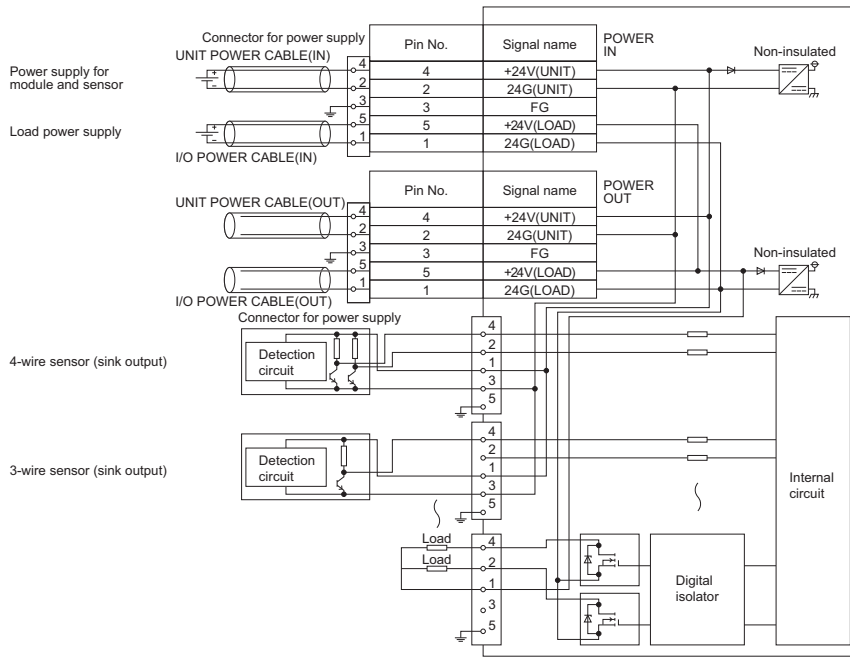

Power supply connectors

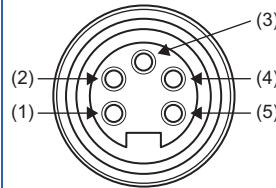
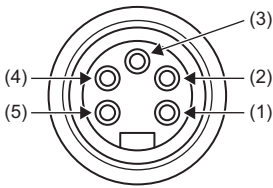

Pin number	Signal name	Pin number	Signal name		
7/8" connector Male (IN)	(1)	24G (LOAD)	7/8" connector Female (OUT)	(1)	24G (LOAD)
	(2)	24G (UNIT)		(2)	24G (UNIT)
	(3)	FG		(3)	FG
	(4)	+24V (UNIT)		(4)	+24V (UNIT)
	(5)	+24V (LOAD)		(5)	+24V (LOAD)

I/O connectors

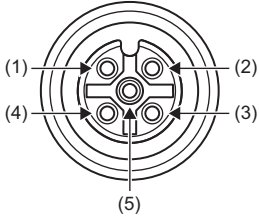

Pin number		Signal name	Pin number		Signal name
X0 X1	(1)	+24V (UNIT)	Y8 Y9	(1)	+24V (LOAD)
	(2)	X1		(2)	Y9
	(3)	24G (UNIT)		(3)	Empty
	(4)	X0		(4)	Y8
	(5)	FG		(5)	FG
X2 X3	(1)	+24V (UNIT)	YA YB	(1)	+24V (LOAD)
	(2)	X3		(2)	YB
	(3)	24G (UNIT)		(3)	Empty
	(4)	X2		(4)	YA
	(5)	FG		(5)	FG
X4 X5	(1)	+24V (UNIT)	YC YD	(1)	+24V (LOAD)
	(2)	X5		(2)	YD
	(3)	24G (UNIT)		(3)	Empty
	(4)	X4		(4)	YC
	(5)	FG		(5)	FG
X6 X7	(1)	+24V (UNIT)	YE YF	(1)	+24V (LOAD)
	(2)	X7		(2)	YF
	(3)	24G (UNIT)		(3)	Empty
	(4)	X6		(4)	YE
	(5)	FG		(5)	FG

Derating chart

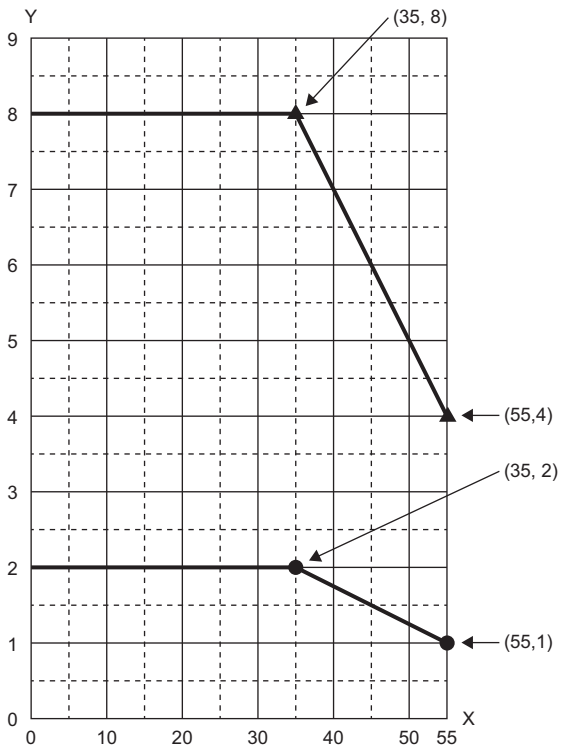

X: Ambient temperature (°C)

Y: Output current (A)

●: Output current per point

▲: Output current per common

NZ2GF12A42-16DTE DC input transistor output module

Item		NZ2GF12A42-16DTE		
		Input specifications	Output specifications	
Station type		Remote device station		
Number of input points		8 points	—	
Rated input voltage		24VDC (ripple rate: 5% or less) (Allowable voltage range: 20.4 to 28.8VDC)		
Rated input current		7mA TYP. (for 24VDC)		
Isolation method		Non-isolation		
Max. number of simultaneous input points		100%		
ON voltage/ON current		15VDC or more/3.5mA or more		
OFF voltage/OFF current		8VDC or less/1.7mA or less		
Input resistance		3.3k Ω		
Input response time* ¹		OFF \rightarrow ON		0ms/0.5ms/1ms/1.5ms/5ms/10ms/20ms/70ms (Initial setting: 10ms)
		ON \rightarrow OFF		
Input type		Negative common (source type)		
Short-circuit detection current of sensor power supply		400mA or more/input connector		
Number of output points		—	8 points	
Rated load voltage		12/24VDC (ripple rate: 5% or less) (Allowable voltage range: 10.2 to 28.8VDC)		
Max. load current		2A/point, 8A/common		
Isolation method		Digital isolator isolation		
Max. inrush current		Current is limited by the overload protection function.		
Leakage current at OFF		0.1mA or less		
Max. voltage drop at ON		0.5VDC (TYP.) 0.5A, 0.8VDC (MAX.) 0.5A		
Output response time* ²		OFF \rightarrow ON	0.5ms or less	
		ON \rightarrow OFF	1.5ms or less (resistance load)	
Surge suppressor		Zener diode		
Output type		Source type		
Protection function		Overload protection function	Limited current when detecting overcurrent: 6.5A or more/point Activated to each point.	
		Overheat protection function	Activated to each point.	
Short-circuit detection current		—	6.5A or more/point	
Withstand voltage		500VAC for 1 minute between all DC external terminals and the ground		
Insulation resistance		10M Ω or higher between all DC external terminals and ground (500VDC insulation resistance tester)		
Protection degree		IP67		
Wiring method for common		8 points/common (2- to 4-wire, waterproof connector type)	8 points/common (2-wire, waterproof connector type)	
External interface		Module power supply part	7/8" waterproof connector, 5 pins, male (IN)/female (OUT)	
		I/O part	M12 waterproof connector, 5 pins, female, A-code	
		Communication part	M12 waterproof connector, 8 pins, female, X-code	
Applicable waterproof connector		For power supply	 Page 14 Recommended Connector List	
		For I/O		
		Y-branch connector for I/O		
		For communications		
Cyclic transmission		RX/R _Y points	16 points	
		R _W r/R _W w points	12 points	
Communication cable		An Ethernet cable that meets the 1000BASE-T standard: Category 5e or higher (double shielded, STP), straight cable		

Item		NZ2GF12A42-16DTE	
		Input specifications	Output specifications
Module power supply	Voltage	24VDC (ripple rate: 5% or less) (Allowable voltage range: 20.4 to 28.8VDC)	
	Current	230mA or less (24VDC, all points ON)	
Weight		0.72kg	

*1 For how to calculate the processing time of the remote device station (input), refer to the point in the following.

☞ Page 20 NZ2GF12A4-16D DC input module

*2 For how to calculate the processing time of the remote device station (output), refer to the point in the following.

☞ Page 26 NZ2GF12A2-16T transistor output module

External connection

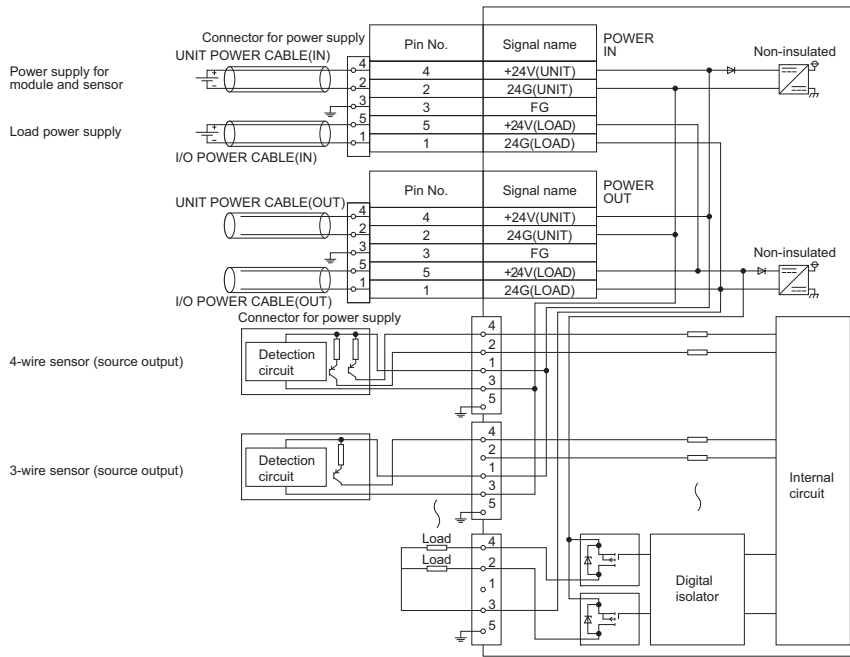

3

Power supply connectors

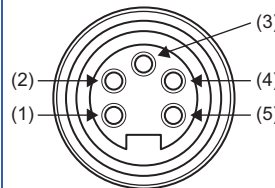
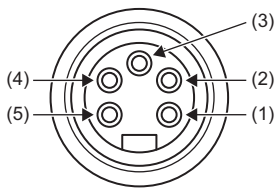

Pin number	Signal name	Pin number	Signal name
7/8" connector Male (IN)	(1) 24G (LOAD)	7/8" connector Female (OUT)	(1) 24G (LOAD)
	(2) 24G (UNIT)		(2) 24G (UNIT)
	(3) FG		(3) FG
	(4) +24V (UNIT)		(4) +24V (UNIT)
	(5) +24V (LOAD)		(5) +24V (LOAD)

I/O connectors

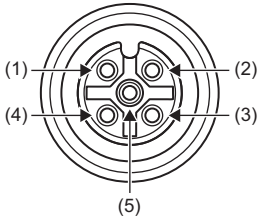

Pin number		Signal name	Pin number		Signal name
X0 X1	(1)	+24V (UNIT)	Y8 Y9	(1)	Empty
	(2)	X1		(2)	Y9
	(3)	24G (UNIT)		(3)	24G (LOAD)
	(4)	X0		(4)	Y8
	(5)	FG		(5)	FG
X2 X3	(1)	+24V (UNIT)	YA YB	(1)	Empty
	(2)	X3		(2)	YB
	(3)	24G (UNIT)		(3)	24G (LOAD)
	(4)	X2		(4)	YA
	(5)	FG		(5)	FG
X4 X5	(1)	+24V (UNIT)	YC YD	(1)	Empty
	(2)	X5		(2)	YD
	(3)	24G (UNIT)		(3)	24G (LOAD)
	(4)	X4		(4)	YC
	(5)	FG		(5)	FG
X6 X7	(1)	+24V (UNIT)	YE YF	(1)	Empty
	(2)	X7		(2)	YF
	(3)	24G (UNIT)		(3)	24G (LOAD)
	(4)	X6		(4)	YE
	(5)	FG		(5)	FG

Derating chart

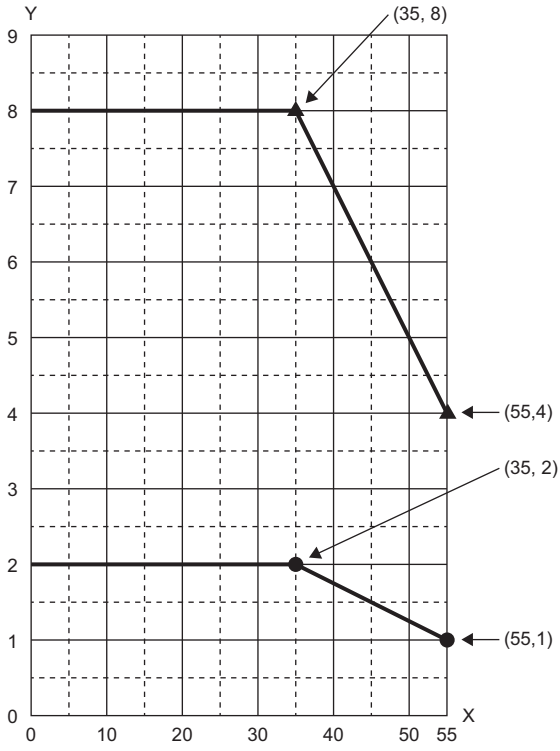

X: Ambient temperature (°C)

Y: Output current (A)

●: Output current per point

▲: Output current per common

3.3 Function List

This section lists the functions of I/O modules.

○: Available, —: Not available

Item	Description	Availability			Reference
		Input module	Output module	I/O combined module	
Error notification function	When an error or warning occurs, the I/O module notifies the master station of it using remote registers.	○	○	○	Page 81 Error Notification Function
Input function	The ON/OFF status (X signal) of inputs is notified to Remote input (RX) which is the buffer memory of the master station.	○	—	○	—
Input OFF delay function	This function turns off an X signal after a predetermined time passed from when an actual input becomes off from on.	○	—	○	Page 84 Input OFF Delay Function
Input response time setting function	This function prevents an incorrect input due to noise by setting the response time until the module recognizes an actual input as the X signal.	○	—	○	Page 86 Input Response Time Setting Function
Output function	The ON/OFF status (Y signal) of outputs is controlled with Remote output (RY) which is the buffer memory of the master station.	—	○	○	—
Output HOLD/CLEAR setting function	When the I/O module is disconnected from data link, or the CPU module operating status is STOP, whether to hold or clear the last output value can be set.	—	○	○	Page 87 Output HOLD/CLEAR Setting Function
Cyclic data update watch function	The update intervals of cyclic data are monitored. The last output value is held or cleared when the cyclic transmission stop status continues longer than the set monitoring time.	—	○	○	Page 88 Cyclic Data Update Watch Function
Number of ON times integration function	The total number of ON times of each output point is counted with this function. The integration value remains even though the output module is powered off.	—	○	○	Page 89 Number of ON Times Integration Function
Output ON/OFF information hold function	This function checks if the output has been turned once on or off.	—	○	○	Page 91 Output ON/OFF Information Hold Function
Power supply monitoring function	This function monitors the power supply status of the module-and-sensor power supply and load power supply.	○	○	○	Page 92 Power Supply Monitoring Function
Short-circuit detection function	This function detects a short circuit in each of input ports and output channels.	○	○	○	Page 93 Short-Circuit Detection Function
Fast logic function	This function controls outputs according to the input status inside the I/O combined module without communications with the master station. High-speed output control can be performed with this function.	—	—	○	Page 95 Fast Logic Function
Initial operation setting function	This function sets whether the initial processing using the program is necessary or not when the data link is established.	○	○	○	Page 98 Initial Operation Setting Function
Protection function	This function protects the internal circuit of the module.	○	○	○	Page 100 Protection Function

Item	Description	Availability			Reference
		Input module	Output module	I/O combined module	
CC-Link IE Field Network diagnostic function	This function allows the presence or absence of a network error to be checked by accessing the engineering tool connected to the CPU module.	○	○	○	Page 100 CC-Link IE Field Network Diagnostic Function

3.4 List of Remote I/O Signals

This section lists I/O signals for a master/local module.

The following shows an assignment example of I/O signals with the remote I/O signals of the I/O module assigned to the I/O numbers of RX0 to RXF and RY0 to RYF.

Remote input (RX) indicates the input signal from the I/O module to the master/local module.

Remote output (RY) indicates the output signal from the master/local module to the I/O module.

The remote I/O signals of the I/O module are assigned as shown below.

Module	Remote input (RX)	Remote output (RY)
I/O module	RX0 to RXF	RY0 to RYF



Do not use any "Use prohibited" remote I/O signals. Doing so may cause an accident due to incorrect output or malfunction.

Input module

The remote I/O signals of the input module are assigned as shown below.

Remote input		Remote output	
Signal direction: Input module → Master/local module		Signal direction: Master/local module → Input module	
Device number	Description	Device number	Description
RX0	External input signal X0	RY0	Use prohibited
RX1	External input signal X1	RY1	
RX2	External input signal X2	RY2	
RX3	External input signal X3	RY3	
RX4	External input signal X4	RY4	
RX5	External input signal X5	RY5	
RX6	External input signal X6	RY6	
RX7	External input signal X7	RY7	
RX8	External input signal X8	RY8	
RX9	External input signal X9	RY9	
RXA	External input signal XA	RYA	
RXB	External input signal XB	RYB	
RXC	External input signal XC	RYC	
RXD	External input signal XD	RYD	
RXE	External input signal XE	RYE	
RXF	External input signal XF	RYF	

Output module

The remote I/O signals of the output module are assigned as shown below.

Remote input		Remote output	
Signal direction: Output module → Master/local module		Signal direction: Master/local module → Output module	
Device number	Description	Device number	Description
RX0	Use prohibited	RY0	External output signal Y0
RX1		RY1	External output signal Y1
RX2		RY2	External output signal Y2
RX3		RY3	External output signal Y3
RX4		RY4	External output signal Y4
RX5		RY5	External output signal Y5
RX6		RY6	External output signal Y6
RX7		RY7	External output signal Y7
RX8		RY8	External output signal Y8
RX9		RY9	External output signal Y9
RXA		RYA	External output signal YA
RXB		RYB	External output signal YB
RXC		RYC	External output signal YC
RXD		RYD	External output signal YD
RXE		RYE	External output signal YE
RXF		RYF	External output signal YF

I/O combined module

The remote I/O signals of the I/O combined module are assigned as shown below.

Remote input		Remote output	
Signal direction: I/O combined module → Master/local module		Signal direction: Master/local module → I/O combined module	
Device number	Description	Device number	Description
RX0	External input signal X0	RY0	Use prohibited
RX1	External input signal X1	RY1	
RX2	External input signal X2	RY2	
RX3	External input signal X3	RY3	
RX4	External input signal X4	RY4	
RX5	External input signal X5	RY5	
RX6	External input signal X6	RY6	
RX7	External input signal X7	RY7	
RX8	Use prohibited	RY8	External output signal Y8
RX9		RY9	External output signal Y9
RXA		RYA	External output signal YA
RXB		RYB	External output signal YB
RXC		RYC	External output signal YC
RXD		RYD	External output signal YD
RXE		RYE	External output signal YE
RXF		RYF	External output signal YF

3.5 List of Remote Register

This section lists remote registers for a master/local module.

The following shows an assignment example of remote registers with the remote registers of the I/O module assigned to the remote registers of RWr0 to RWrB and RWw0 to RWwB.

The remote registers are assigned in station-based units.

Remote register (RWr) is the information input from the I/O module to the master/local module.

Remote register (RWw) is the information output from the master/local module to the I/O module.

For details on the remote register, refer to the following.

 Page 144 Details of Remote Registers

Point

Do not read or write data from/to any "Use prohibited" remote registers. Doing so may cause an accident due to incorrect output or malfunction.

Input module

Remote register (RWr)		Remote register (RWw)	
Signal direction: Input module → Master/local module		Signal direction: Master/local module → Input module	
Device number	Name	Device number	Name
RWr0	Module status area	RWw0	Module operation area
RWr1	Error code	RWw1	Use prohibited
RWr2	Warning code	RWw2	Use prohibited
RWr3	Function selection status flag	RWw3	Function selection setting flag
RWr4	Input X port status	RWw4	Use prohibited
RWr5	Use prohibited	RWw5	Use prohibited
RWr6	Use prohibited	RWw6	Use prohibited
RWr7	Use prohibited	RWw7	Use prohibited
RWr8	Use prohibited	RWw8	Use prohibited
RWr9	Use prohibited	RWw9	Use prohibited
RWrA	Use prohibited	RWwA	Use prohibited
RWrB	Use prohibited	RWwB	Use prohibited

Point

For the output ON/OFF information hold function, refer to the following.

 Page 91 Output ON/OFF Information Hold Function

Output module

Remote register (RWr)		Remote register (RWw)	
Signal direction: Output module → Master/local module		Signal direction: Master/local module → Output module	
Device number	Name	Device number	Name
RWr0	Module status area	RWw0	Module operation area
RWr1	Error code	RWw1	Use prohibited
RWr2	Warning code	RWw2	Use prohibited
RWr3	Function selection status flag	RWw3	Function selection setting flag
RWr4	Use prohibited	RWw4	Use prohibited
RWr5	Output Y channel status	RWw5	Use prohibited
RWr6	Output Y current value Y0 to YF	RWw6	Use prohibited
RWr7	Output Y ON information Y0 to YF	RWw7	Output Y ON information clear request Y0 to YF
RWr8	Output Y OFF information Y0 to YF	RWw8	Output Y OFF information clear request Y0 to YF
RWr9	Use prohibited	RWw9	Use prohibited
RWrA	Use prohibited	RWwA	Use prohibited
RWrB	Use prohibited	RWwB	Use prohibited

Point

For the output ON/OFF information hold function, refer to the following.

☞ Page 91 Output ON/OFF Information Hold Function

I/O combined module

Remote register (RWr)		Remote register (RWw)	
Signal direction: I/O combined module → Master/local module		Signal direction: Master/local module → I/O combined module	
Device number	Name	Device number	Name
RWr0	Module status area	RWw0	Module operation area
RWr1	Error code	RWw1	Use prohibited
RWr2	Warning code	RWw2	Use prohibited
RWr3	Function selection status flag	RWw3	Function selection setting flag
RWr4	Input X port status	RWw4	Use prohibited
RWr5	Output Y channel status	RWw5	Use prohibited
RWr6	Output Y current value Y8 to YF	RWw6	Use prohibited
RWr7	Output Y ON information Y8 to YF	RWw7	Output Y ON information clear request Y8 to YF
RWr8	Output Y OFF information Y8 to YF	RWw8	Output Y OFF information clear request Y8 to YF
RWr9	Use prohibited	RWw9	Use prohibited
RWrA	Use prohibited	RWwA	Use prohibited
RWrB	Use prohibited	RWwB	Use prohibited

Point

For the output ON/OFF information hold function, refer to the following.

☞ Page 91 Output ON/OFF Information Hold Function

3.6 List of Remote Buffer Memory

This section lists the remote buffer memory areas of the I/O module.

The remote buffer memory areas of the I/O module are assigned as shown below.

Description of a remote buffer memory area

■ I/O response time setting (address: 0000H)

The following shows the description of I/O response time setting (address: 0000H) as an example.

Item	Description
I/O response time setting	Setting item
(address: 0000H)	Remote buffer memory address

■ Input OFF delay setting X□ (address: 0110H to 012FH)

The following shows the description of Input OFF delay setting X□ (address: 0110H to 012FH) as an example.

Item	Description
Input OFF delay setting	Setting item
X□	Input signal or output signal
(address: 0110H to 012FH)	Remote buffer memory address

For details on the remote buffer memory, refer to the following.

☞ Page 154 Details of Remote Buffer Memory Addresses

○: Available, ×: Not available

Address		Area	Target		Access method		
Decimal	Hexadecimal				CC IE Field configuration of the engineering tool	REMFR instruction, REMTO instruction ^{*1}	
0 to 255	0000H to 00FFH	Parameter area	Station-based parameter data		○ ^{*2}	○	
256 to 511	0100H to 01FFH		Module-based parameter data	I/O module			
512 to 767	0200H to 02FFH			System area			
768 to 1023	0300H to 03FFH			System area			
1024 to 1279	0400H to 04FFH			System area			
1280 to 1535	0500H to 05FFH	Monitoring area	Station-based monitor data		×	○	
1536 to 1791	0600H to 06FFH		Module-based monitor data	I/O module			
1792 to 2047	0700H to 07FFH			System area			
2048 to 2303	0800H to 08FFH			System area			
2304 to 2559	0900H to 09FFH			System area			
2560 to 4095	0A00H to 0FFFH	Error history area	Station-based error history data		○ ^{*2}	○	
4096 to 4351	1000H to 10FFH	Module control data area	Station-based control data		×	○	
4352 to 4607	1100H to 11FFH		Module-based control data	I/O module			
4608 to 4863	1200H to 12FFH			System area			
4864 to 5119	1300H to 13FFH			System area			
5120 to 5375	1400H to 14FFH			System area			

*1 For the REMFR and REMTO instructions, refer to the following.

☞ User's manual for the master/local module used

*2 For the access method, refer to the following.

Parameter area (☞ Page 72 Parameter Setting)

Error history area (☞ Page 121 Checking for the Error Codes and the Warning Codes)

- Do not access the system area using the REMFR or REMTO instruction. Doing so may lead the module to malfunction.
- Do not use the dedicated instruction of the REMFR and REMTO instructions to the areas later than the above areas. If these instructions are used, the error code (0202H) is stored in Warning code (RWr2), Warning status flag (RWr0.b12) turns on, and the ERR. LED flashes.

Parameter area (address: 0000H to 04FFH)

For the parameter area, parameters can be set by means of the CC IE Field configuration of the engineering tool, or the REMTO instruction.

The parameter in the parameter area is backed up to the nonvolatile memory.

However, Fast logic setting Y□ (address: 0120H to 0127H) is not backed up. The parameter backed up to the nonvolatile memory is read to the parameter area when the module power supply is turned off and on or the module returns from remote reset.

For the parameters written from the parameter settings of the CC IE Field configuration of the engineering tool, the write to the non-volatile memory is also completed at the same time. When the parameter is written using the REMTO instruction, it is written to the nonvolatile memory when Operation condition setting request flag (RWw0.b9) is turned on. At this time, the parameter is written to the nonvolatile memory even though it is incorrect. When the power supply is turned off and on with an incorrect parameter written, the incorrect parameter is read from the nonvolatile memory and an error code is stored to Error code (RWr1). Take corrective action according to the error code list. (☞ Page 124 Error Code List)

■Input module

R: Can be read from a program, W: Can be written to a program

Type	Address		Input module		
	Decimal	Hexadecimal	Name	Default value *1	Read/Write
Station-based parameter data	0	0000H	Input response time setting	0005H	R/W
	1	0001H	System area	—	—
	2	0002H	System area	—	—
	3	0003H	System area	—	—
	4	0004H	Initial operation setting	0001H	R/W
	5 to 255	0005H to 00FFH	System area	—	—
Module-based parameter data	256 to 271	0100H to 010FH	System area	—	—
	272	0110H	Input OFF delay setting X0	0	R/W
	273	0111H			
	274	0112H	Input OFF delay setting X1	0	R/W
	275	0113H			
	276	0114H	Input OFF delay setting X2	0	R/W
	277	0115H			
	278	0116H	Input OFF delay setting X3	0	R/W
	279	0117H			
	280	0118H	Input OFF delay setting X4	0	R/W
	281	0119H			
	282	011AH	Input OFF delay setting X5	0	R/W
	283	011BH			
	284	011CH	Input OFF delay setting X6	0	R/W
	285	011DH			
	286	011EH	Input OFF delay setting X7	0	R/W
	287	011FH			
	288	0120H	Input OFF delay setting X8	0	R/W
	289	0121H			
	290	0122H	Input OFF delay setting X9	0	R/W
	291	0123H			
	292	0124H	Input OFF delay setting XA	0	R/W
	293	0125H			
	294	0126H	Input OFF delay setting XB	0	R/W
	295	0127H			
	296	0128H	Input OFF delay setting XC	0	R/W
	297	0129H			
	298	012AH	Input OFF delay setting XD	0	R/W
	299	012BH			
	300	012CH	Input OFF delay setting XE	0	R/W
	301	012DH			
	302	012EH	Input OFF delay setting XF	0	R/W
303	012FH				
304 to 511	0130H to 01FFH	System area	—	—	
System area	512 to 1279	0200H to 04FFH	System area	—	—

*1 This value is the factory default value or the value after the initialization by Parameter area initialization command (address: 1002H).

■Output module

R: Can be read from a program, W: Can be written to a program

Type	Address		Output module		
	Decimal	Hexadecimal	Name	Default value ^{*1}	Read/Write
Station-based parameter data	0	0000H	System area	—	—
	1	0001H	Output HOLD/CLEAR setting	0000H	R/W
	2	0002H	Cyclic data update watch time setting	0000H	R/W
	3	0003H	System area	—	—
	4	0004H	Initial operation setting	0001H	R/W
	5 to 255	0005H to 00FFH	System area	—	—
Module-based parameter data	256	0100H	System area	—	—
	257	0101H			
	258	0102H	Number of ON times integration function enable Y0 to YF	0000H	R/W
	259 to 511	0103H to 01FFH	System area	—	—
System area	512 to 1279	0200H to 04FFH	System area	—	—

*1 This value is the factory default value or the value after the initialization by Parameter area initialization command (address: 1002H).

■ I/O combined module

R: Can be read from a program, W: Can be written to a program

Type	Address		I/O module		
	Decimal	Hexadecimal	Name	Default value *1	Read/Write
Station-based parameter data	0	0000H	Input response time setting	0005H	R/W
	1	0001H	Output HOLD/CLEAR setting	0000H	R/W
	2	0002H	Cyclic data update watch time setting	0000H	R/W
	3	0003H	System area	—	—
	4	0004H	Initial operation setting	0001H	R/W
	5 to 255	0005H to 00FFH	System area	—	—
Module-based parameter data	256	0100H	System area	—	—
	257	0101H			
	258	0102H	Number of ON times integration function enable Y8 to YF	0000H	R/W
	259 to 271	0103H to 010FH	System area	—	—
	272	0110H	Input OFF delay setting X0	0	R/W
	273	0111H			
	274	0112H	Input OFF delay setting X1	0	R/W
	275	0113H			
	276	0114H			
	277	0115H	Input OFF delay setting X2	0	R/W
	278	0116H			
	279	0117H	Input OFF delay setting X3	0	R/W
	280	0118H			
	281	0119H			
	282	011AH	Input OFF delay setting X5	0	R/W
	283	011BH			
	284	011CH	Input OFF delay setting X6	0	R/W
	285	011DH			
	286	011EH	Input OFF delay setting X7	0	R/W
	287	011FH			
	288	0120H	Fast logic setting Y8	0	R/W
	289	0121H			
	290	0122H	Fast logic setting Y9	0	R/W
	291	0123H			
	292	0124H	Fast logic setting YA	0	R/W
	293	0125H			
	294	0126H	Fast logic setting YB	0	R/W
	295	0127H			
	296 to 511	0128H to 01FFH	System area	—	—
	System area	512 to 1279	0200H to 04FFH	System area	—

*1 This value is the factory default value or the value after the initialization by Parameter area initialization command (address: 1002H).

Monitoring area (address: 0500H to 09FFH)

■Input module

R: Can be read from a program, W: Can be written to a program

Type	Address		Input module	
	Decimal	Hexadecimal	Name	Read/Write
Station-based monitor data	1280 to 1535	0500H to 05FFH	System area	—
Module-based monitor data	1536 to 1791	0600H to 06FFH	System area	—
System area	1792 to 2559	0700H to 09FFH	System area	—

3



Default values are not determined in the monitoring area.

■Output module

R: Can be read from a program, W: Can be written to a program

Type	Address		Output module	
	Decimal	Hexadecimal	Name	Read/Write
Station-based monitor data	1280 to 1535	0500H to 05FFH	System area	—
Module-based monitor data	1536 to 1551	0600H to 060FH	System area	—
	1552	0610H	Number of ON times integration value Y0	R
	1553	0611H		
	1554	0612H	Number of ON times integration value Y1	R
	1555	0613H		
	1556	0614H	Number of ON times integration value Y2	R
	1557	0615H		
	1558	0616H	Number of ON times integration value Y3	R
	1559	0617H		
	1560	0618H	Number of ON times integration value Y4	R
	1561	0619H		
	1562	061AH	Number of ON times integration value Y5	R
	1563	061BH		
	1564	061CH	Number of ON times integration value Y6	R
	1565	061DH		
	1566	061EH	Number of ON times integration value Y7	R
	1567	061FH		
	1568	0620H	Number of ON times integration value Y8	R
	1569	0621H		
	1570	0622H	Number of ON times integration value Y9	R
	1571	0623H		
	1572	0624H	Number of ON times integration value YA	R
	1573	0625H		
	1574	0626H	Number of ON times integration value YB	R
	1575	0627H		
	1576	0628H	Number of ON times integration value YC	R
	1577	0629H		
	1578	062AH	Number of ON times integration value YD	R
	1579	062BH		
	1580	062CH	Number of ON times integration value YE	R
1581	062DH			
1582	062EH	Number of ON times integration value YF	R	
1583	062FH			
	1584 to 1791	0630H to 06FFH	System area	—
System area	1792 to 2559	0700H to 09FFH	System area	—

Default values are not determined in the monitoring area.

■ I/O combined module

R: Can be read from a program, W: Can be written to a program

Type	Address		I/O combined module	
	Decimal	Hexadecimal	Name	Read/Write
Station-based monitor data	1280 to 1535	0500H to 05FFH	System area	—
Module-based monitor data	1536	0600H	System area	—
	1537	0601H		
	1538	0602H	Fast logic enable status Y8 to YB	R
	1539 to 1567	0603H to 061FH	System area	—
	1568	0620H	Number of ON times integration value Y8	R
	1569	0621H		
	1570	0622H	Number of ON times integration value Y9	R
	1571	0623H		
	1572	0624H	Number of ON times integration value YA	R
	1573	0625H		
	1574	0626H	Number of ON times integration value YB	R
	1575	0627H		
	1576	0628H	Number of ON times integration value YC	R
	1577	0629H		
	1578	062AH	Number of ON times integration value YD	R
	1579	062BH		
	1580	062CH	Number of ON times integration value YE	R
	1581	062DH		
	1582	062EH	Number of ON times integration value YF	R
	1583	062FH		
1584 to 1791	0630H to 06FFH	System area	—	
System area	1792 to 2559	0700H to 09FFH	System area	—

Default values are not determined in the monitoring area.

Error history area (address: 0A00H to 0FFFH)

■Common to input modules, output modules, and I/O combined modules

R: Can be read from a program, W: Can be written to a program

Address		Common to input modules, output modules, and I/O combined modules			
Decimal	Hexadecimal	Name		Default value ^{*1}	Read/Write
2560	0A00H	Error history data 1	Error code	0000H	R
2561	0A01H		Order of generation	0000H	R
2562	0A02H		[Error time] First two digits of the year/Last two digits of the year	0000H	R
2563	0A03H		[Error time] Month/Day	0000H	R
2564	0A04H		[Error time] Hour/Minute	0000H	R
2565	0A05H		[Error time] Second/00H (Fixed)	0000H	R
2566	0A06H		Error code details 1	0000H	R
2567	0A07H		Error code details 2	0000H	R
2568	0A08H		Error code details 3	0000H	R
2569	0A09H		Error code details 4	0000H	R
2570	0A0AH		Error code details 5	0000H	R
2571	0A0BH		Error code details 6	0000H	R
2572	0A0CH		Error code details 7	0000H	R
2573	0A0DH		Error code details 8	0000H	R
2574	0A0EH		Error code details 9	0000H	R
2575	0A0FH	Error code details 10	0000H	R	
2576 to 2591	0A10H to 0A1FH	Error history data 2	Same as Error history data 1.		
2592 to 2607	0A20H to 0A2FH	Error history data 3	Same as Error history data 1.		
2608 to 2623	0A30H to 0A3FH	Error history data 4	Same as Error history data 1.		
2624 to 2639	0A40H to 0A4FH	Error history data 5	Same as Error history data 1.		
2640 to 2655	0A50H to 0A5FH	Error history data 6	Same as Error history data 1.		
2656 to 2671	0A60H to 0A6FH	Error history data 7	Same as Error history data 1.		
2672 to 2687	0A70H to 0A7FH	Error history data 8	Same as Error history data 1.		
2688 to 2703	0A80H to 0A8FH	Error history data 9	Same as Error history data 1.		
2704 to 2719	0A90H to 0A9FH	Error history data 10	Same as Error history data 1.		
2720 to 2735	0AA0H to 0AAFH	Error history data 11	Same as Error history data 1.		
2736 to 2751	0AB0H to 0ABFH	Error history data 12	Same as Error history data 1.		
2752 to 2767	0AC0H to 0ACFH	Error history data 13	Same as Error history data 1.		
2768 to 2783	0AD0H to 0ADFH	Error history data 14	Same as Error history data 1.		
2784 to 2799	0AE0H to 0AEFH	Error history data 15	Same as Error history data 1.		
2800 to 4095	0AF0H to 0FFFH	System area		—	—

*1 This value is the factory default value or the value after the initialization by Error history clear command (address: 1000H).

Module control data area (address: 1000H to 14FFH)

■Input module

R: Can be read from a program, W: Can be written to a program

Type	Address		Input module		
	Decimal	Hexadecimal	Name	Default value ^{*1}	Read/Write
Station-based control data	4096	1000H	Error history clear command	0000H	R/W
	4097	1001H	Error history clear completed	0000H	R
	4098	1002H	Parameter area initialization command	0000H	R/W
	4099	1003H	Parameter area initialization completed	0000H	R
	4100	1004H	Module operation information initialization command	0000H	R/W
	4101	1005H	Module operation information initialization completed	0000H	R
	4102 to 4351	1006H to 10FFH	System area	—	—
Module-based control data	4352 to 4607	1100H to 11FFH	System area	—	—
System area	4608 to 5375	1200H to 14FFH	System area	—	—

*1 This is the value for when the module power supply is turned off and on or at the remote reset.

■Output module

R: Can be read from a program, W: Can be written to a program

Type	Address		Output module		
	Decimal	Hexadecimal	Name	Default value ^{*1}	Read/Write
Station-based control data	4096	1000H	Error history clear command	0000H	R/W
	4097	1001H	Error history clear completed	0000H	R
	4098	1002H	Parameter area initialization command	0000H	R/W
	4099	1003H	Parameter area initialization completed	0000H	R
	4100	1004H	Module operation information initialization command	0000H	R/W
	4101	1005H	Module operation information initialization completed	0000H	R
	4102 to 4351	1006H to 10FFH	System area	—	—
Module-based control data	4352	1100H	Number of ON times integration value clear request Y0 to YF	0000H	R/W
	4353	1101H	Number of ON times integration value clear completed Y0 to YF	0000H	R
	4354 to 4607	1102H to 11FFH	System area	—	—
System area	4608 to 5375	1200H to 14FFH	System area	—	—

*1 This is the value for when the module power supply is turned off and on or at the remote reset.

■I/O combined module

R: Can be read from a program, W: Can be written to a program

Type	Address		I/O combined module		
	Decimal	Hexadecimal	Name	Default value *1	Read/Write
Station-based control data	4096	1000H	Error history clear command	0000H	R/W
	4097	1001H	Error history clear completed	0000H	R
	4098	1002H	Parameter area initialization command	0000H	R/W
	4099	1003H	Parameter area initialization completed	0000H	R
	4100	1004H	Module operation information initialization command	0000H	R/W
	4101	1005H	Module operation information initialization completed	0000H	R
	4102 to 4351	1006H to 10FFH	System area	—	—
Module-based control data	4352	1100H	Number of ON times integration value clear command Y8 to YF	0000H	R/W
	4353	1101H	Number of ON times integration value clear completed Y8 to YF	0000H	R
	4354 to 4607	1102H to 11FFH	System area	—	—
System area	4608 to 5375	1200H to 14FFH	System area	—	—

*1 This is the value for when the module power supply is turned off and on or at the remote reset.

4 PROCEDURES BEFORE OPERATION

This chapter describes the procedures before operation.

1. Station number setting

Set the station number of the I/O module with the station number setting switch.

☞ Page 64 Station number setting with the station number setting switch

2. Wiring

Wire a power supply, an Ethernet cable, and an external device to the I/O module.

☞ Page 68 Wiring the Power Supply

☞ Page 69 Wiring of Ethernet Cable

3. Parameter setting and programming

Set parameters and create a program.

☞ Page 72 Parameter Setting

☞ Page 77 Changing the Parameter*¹

☞ Page 103 PROGRAMMING

*¹ To replace the module, refer to the point below.

Point

To replace the module, follow the procedure described below:

- Turn off the module power supply and remove the I/O module.
 - Prepare a new I/O module and perform the procedure above from "Station number setting" to "Parameter setting and programming". (The network parameter of the master station does not need to be set again.)
 - After checking the operation, restart the control.
-

5 SYSTEM CONFIGURATION

This chapter describes system configuration using an I/O module.
For CC-Link IE Field Network configuration, refer to the following.

 User's manual for the master/local module used

5.1 Applicable Systems

Applicable master station

When using an I/O module, use the following products as a master station.

Model	First five digits of serial number
RJ71GF11-T2	(no restriction)
RJ71EN71	
QJ71GF11-T2	"14102" or later
LJ71GF11-T2	
QD77GF16	"14111" or later

Information on "Applicable master station" described above is the ones at the point when this manual was issued.
For latest information, please visit the website of CC-Link Partner Association.
www.cc-link.org

Ethernet cable

Use a general-purpose Ethernet cable that meets the 1000BASE-T standard.
Consider the operating environment when selecting available cables that satisfy the product specifications.

Available software

The following software is available for settings and diagnostics of the I/O module. ( Manuals of each software)

Product name	Function and application
GX Works2	Software for system design, programming, debugging, and maintenance of the programmable controller.
GX Works3	

Applicable profile

To use the parameter setting function of an I/O module, the profile is required.
When the latest profile of the remote I/O module is necessary, please consult your local Mitsubishi representative.
The profile is a setting file that stores information required for the start-up, operation, and maintenance of devices supporting the CC-Link family.
A module is added to "Module List" of "CC IE Field Configuration" window by profile registration to an engineering tool. For the profile registration, refer to the operating manual for the engineering tool used.

6 INSTALLATION AND WIRING

This chapter describes the installation and wiring of the I/O module.

6.1 Setting Switch

Station number setting with the station number setting switch

Setting procedure

Set a station number with the station number setting switch on the front of the module. The setting value of the station number becomes valid when the module is powered on. Thus, set the station number when the module is powered off.

1. Loosen the screw for the station number setting switch cover with a screwdriver and open the cover.

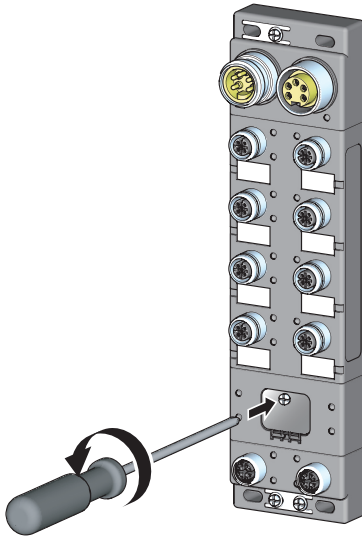

2. Set a station number.*1
 - The hundreds and tens places of the station number are set with x10.
 - The ones place of the station number is set with x1.
3. After setting the station number with the station number setting switch, always close the station number setting switch cover and tighten the screw for the cover with a screwdriver.*2 When the cover is open or the screw has not been tightened properly, waterproof performance is lost.

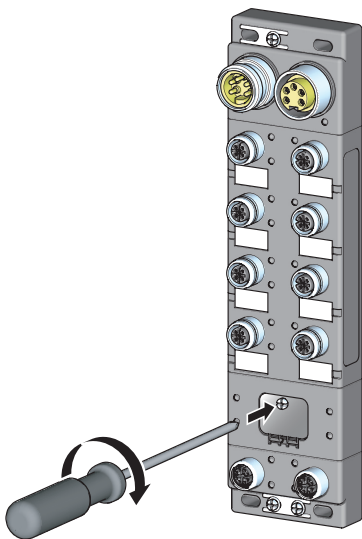

*1 When operating the station number setting switch, use a flathead screwdriver with 3.5mm or less width of the tip.

*2 For the tightening torque range of the screw for the station number setting switch cover, refer to the following.

☞ Page 65 Tightening torque

Ex.

To set the station to 115, set the switch as shown below.

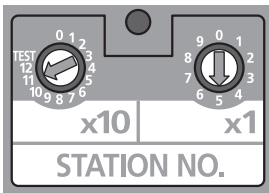

Setting range

Set the station number from 1 to 120. Setting the value other than 1 to 120 causes a communication error and the D LINK LED flashes.

Point

- Do not change the station number setting switch while the module is powered on. Changing the station number setting switch causes a minor error and flashes the ERR. LED. Returning the station number setting switches to the previous setting eliminates the error after five seconds and turns off the ERR. LED.
- Do not set a station number duplicated with other station numbers. If the station number is duplicated, a communication error occurs and the D LINK LED does not turn on.

Tightening torque

Tighten the screw for the station number setting switch cover within the following tightening torque range.

Screw type	Tightening torque range
Station number setting switch cover (M3 screw)	0.43 to 0.57N·m

Point

- Do not put oil on the screw. Failure to do so may damage the screw.
- Tighten the screw with an applicable screwdriver. Tightening it with an inapplicable screwdriver may damage the screw.

6.2 Installation Environment and Installation Position

Installation environment

Installation location

Do not install the I/O module to the place where:

- Ambient temperature is outside the range of 0 to 55°C;
- IP67 is not satisfied;
- Condensation occurs due to rapid temperature change;
- Corrosive gas or combustible gas is present;
- Conductive powder such as iron powder, oil mist, salinity, or organic solvent is filled;
- The I/O module is exposed to direct sunlight;
- A strong electric field or strong magnetic field is generated; and
- The I/O module is subject to vibration and shock.

Installation surface

Install the I/O module on the flat surface. When the installation surface is uneven, excessive force is applied to the printed-circuit board and may cause a defect.

Installation position

When installing the I/O module, provide a clearance of 50mm or longer between the module and the sides of neighboring structures or parts for the following reasons.

- To ensure good ventilation
- To avoid interference
- To avoid stress on waterproof connectors

To insert or remove a communication connector, provide a clearance sufficient to use a screwdriver.

When using a right-angle, waterproof connector or a Y branch connector, provide a clearance to avoid stress on cables.

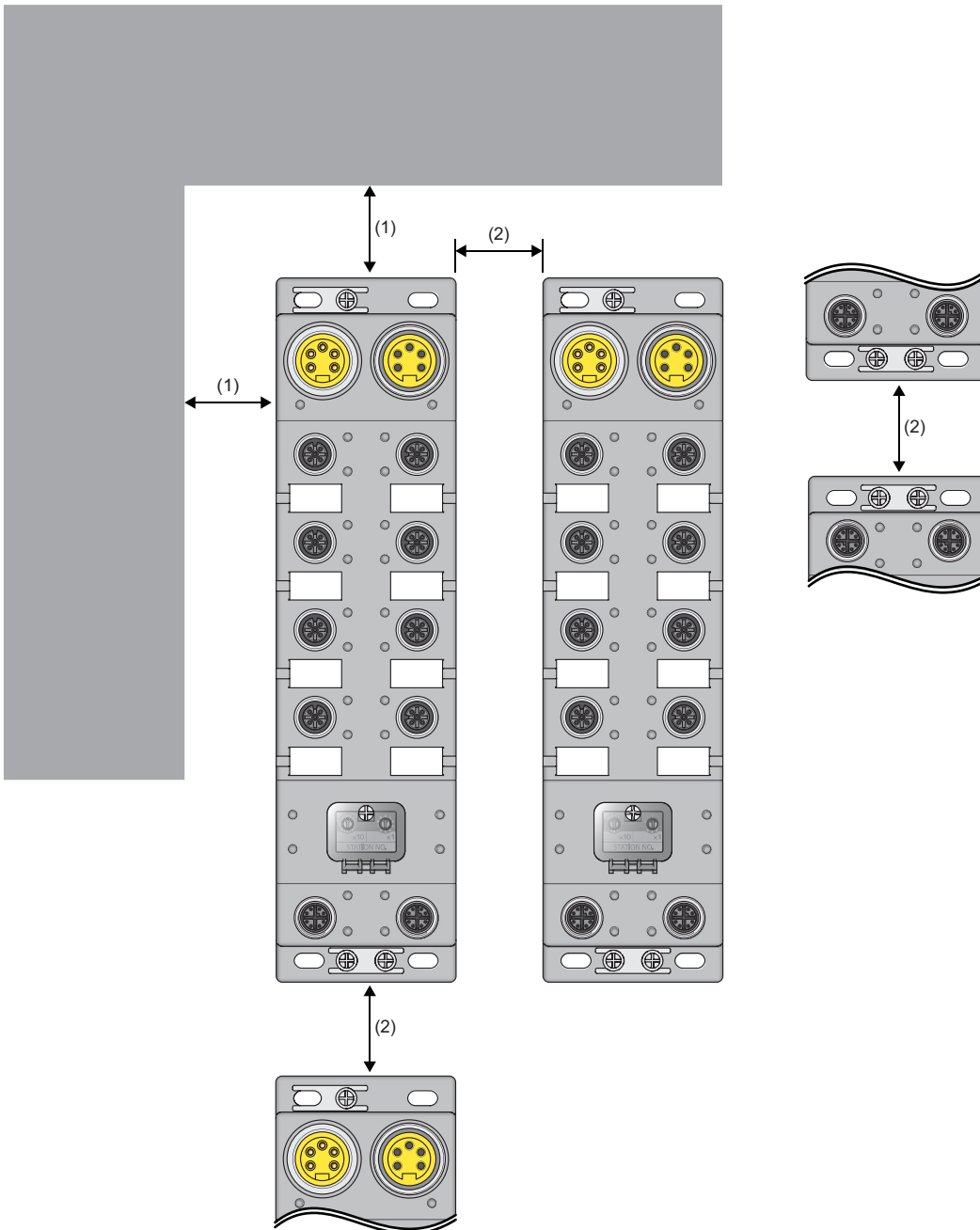

- (1) 0mm or longer
(2) 50mm or longer

Installation direction

The I/O module can be installed in six directions.

Fix the module with screws.

6.3 Installation

Fixing the I/O module

When fixing the I/O module, tighten all of four screws.

Otherwise, the module will be greatly affected by vibration, causing failure of the module.

When installing the module, tighten screws within the following torque range.

Screw type	Tightening torque range
Module mounting screw (M4 screw)	0.83 to 1.11N·m
Screw for an FG metal fitting (M3 screw)	0.43 to 0.57N·m

Point

- Do not put oil on the screw. Failure to do so may damage the screw.
- Tighten the screw with an applicable screwdriver. Tightening it with an inapplicable screwdriver may damage the screw.

6.4 Wiring the Power Supply

When wiring the power supply, wire the POWER IN terminal and the power supply connector of the I/O module.

Transition wiring of the power supply

When installing multiple I/O modules, the power can be supplied to the modules through transition wiring.

For transition wiring, connect wires between the POWER OUT terminal of the I/O module that will be the power supplier and the POWER IN terminal of another I/O module that will be a power supply destination.

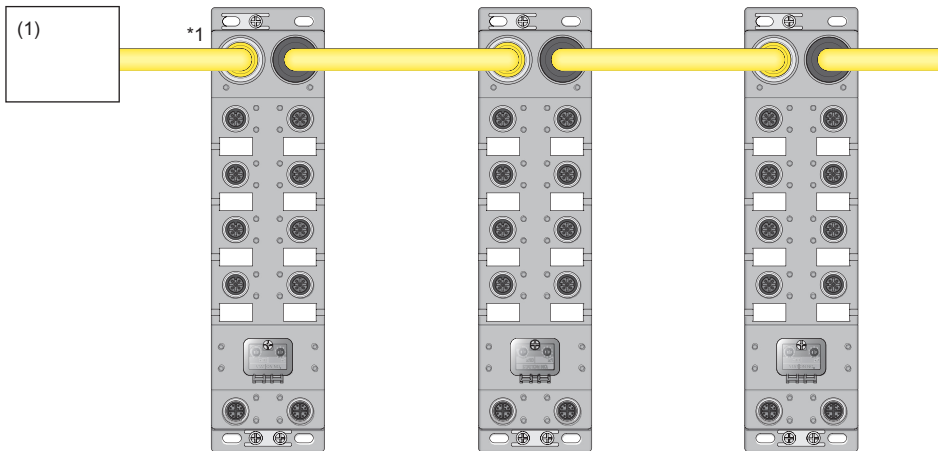

*1 The largest current flows from the power supplier to the power supply connector of the first I/O module. Make sure that the current does not exceed the current capacity (8A/pin) of the power supply connector. For a power supply to supply 24VDC, use a power supply (SELV power supply) that does not exceed 30VAC (effective value), 42.4V (peak value), or 60VDC. Also, use a power supply which is applied to "limited-energy circuit" defined in IEC61010-1.

(1) Power supply

Point

For transition wiring, check the current consumption of each of wired I/O modules.

For the current consumption of an I/O module, refer to the following.

☞ Page 20 I/O Module Specifications

6.5 Wiring of Ethernet Cable

Connecting the Ethernet cable

■Connecting

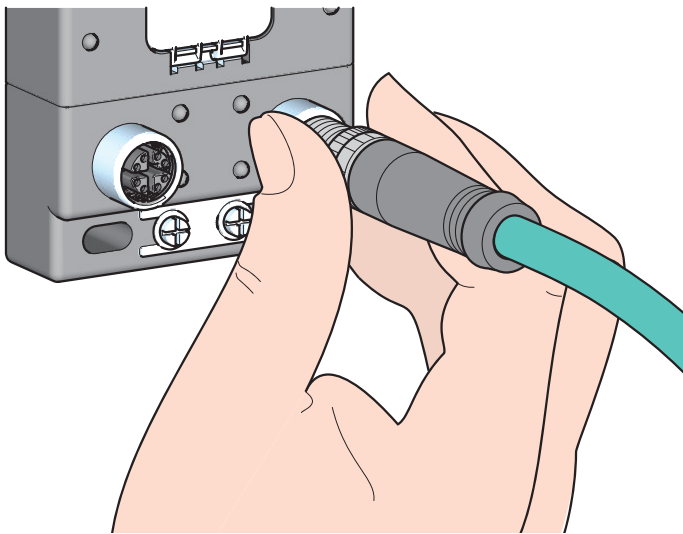
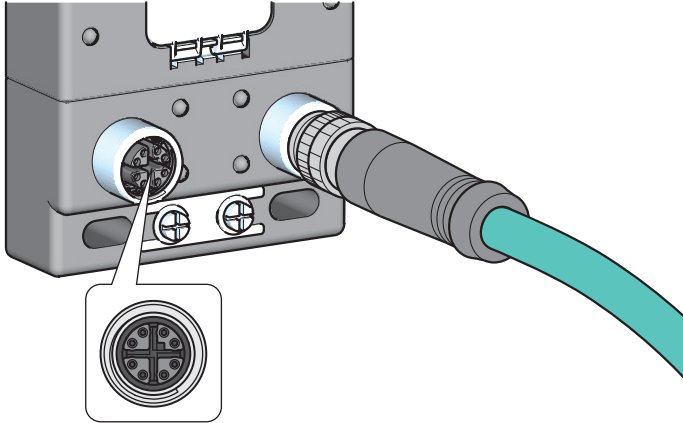

1. Power off the power supplies of the I/O module and the external device.
2. Insert an Ethernet cable connector into the I/O module. Pay attention to the connector's direction.

3. Tighten the screw of the Ethernet cable.

4. Power on the module.
5. Power on the external device.
6. Check that the LINK LED of the port into which the Ethernet cable is connected is on. ^{*1}

*1 The time taken for the LINK LED to turn on after connection of the cable may vary. The LINK LED normally turns on in a few second. However, if link-up processing is repeated due to a condition of a device on the line, the longer time may be required. If the LINK LED does not turn on, refer to the following and take a corrective action.

☞ Page 130 When the LINK LED turns off

- PORT1 and PORT2 need not to be distinguished. When only one connector is used in star topology, either PORT1 or PORT2 can be connected.
- When two connectors are used in line topology or ring topology, an Ethernet cable can be connected to the connectors in any combination. For example, the cable can be connected between PORT1s and between PORT1 and PORT2.
- Connection between PORT1 and PORT1 or between PORT2 and PORT2

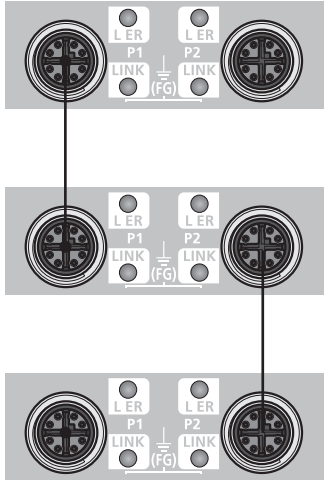

- Connection between PORT1 and PORT2

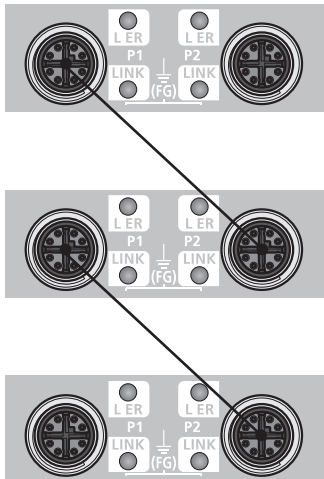

■ Disconnecting

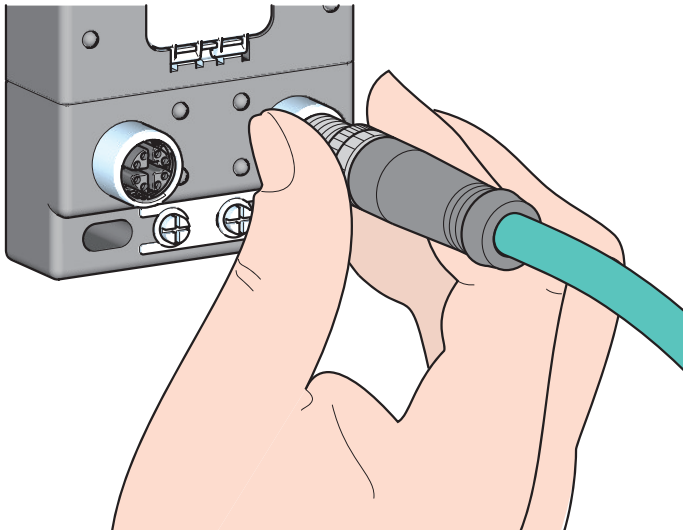

1. Power off the module.
2. Loosen the screw of the Ethernet cable and remove the Ethernet cable.

Precautions

■ Laying Ethernet cables

- Place the Ethernet cable in a duct or clamp them. If not, dangling cable may swing or inadvertently be pulled, resulting in damage to the module or cables or malfunction due to poor contact.
- Do not touch the core of the connector of the cable or the module, and protect it from dirt and dust. If any oil from your hand, or any dirt or dust sticks to the core, it can increase transmission loss, causing data link to fail.
- Check the following:
 - Is any Ethernet cable disconnected?
 - Does any Ethernet cable short?
 - Are the connectors securely connected?

■ Connecting and disconnecting the Ethernet cable

Hold the connector part when connecting and disconnecting the Ethernet cable. Pulling the cable connected to the module may result in damage to the module or cable or malfunction due to poor contact.

■ Connectors without Ethernet cable

To prevent dust from entering the module, attach the provided waterproof caps.

■ Maximum station-to-station distance (Maximum Ethernet cable length)

The maximum station-to-station distance is 100m. However, the distance may be shorter depending on the operating environment of the cable. For details, contact the manufacturer of the cables used.

■ Bending radius of the Ethernet cable

There are restrictions on the bending radius of the Ethernet cable. Check the bending radius in the specifications of the Ethernet cables used.

6.6 Attaching Waterproof Caps

Tighten the waterproof caps within the following torque range.

Screw type	Tightening torque range
Waterproof cap	0.30 to 0.34N-m

7 VARIOUS SETTINGS

This chapter describes the setting procedures of the I/O module.
Details are described using GX Works2.

7.1 Parameter Setting

Set the parameter of this module with the network parameter written to the CPU module of the master station. For the setting procedure of the master station, refer to the following.

 User's manual for the master/local module used

Precautions

■Precautions before parameter settings

For the precautions before parameter settings, refer to the following.

 GX Works3 Operating Manual

 GX Works2 Version 1 Operating Manual (Common)

■Precautions for parameter settings

- When using the I/O module, always enable the block data assurance per station. When it is disabled, correct operation of the I/O module cannot be guaranteed. For details on the block data assurance per station, refer to the following: User's manual for the master/local module used.

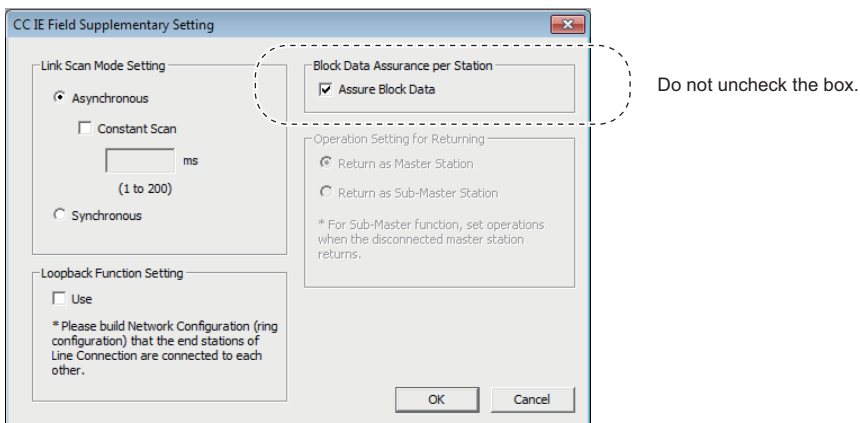

- Do not set the parameter using the CCPASET instruction in the master station. Correct operation of the I/O module cannot be guaranteed because the module operates with the block data assurance per station disabled when the CCPASET instruction is executed. (The CCPASET instruction is intended to configure parameters for a master/local module. For details on the CCPASET instruction, refer to the user's manual for the master/local module used.)
- When the number of points of remote I/O signals and remote registers is set to less than that of the I/O module has, no error occurs. The cyclic transmission is performed for the data of the points set from the start.

Operation procedure

1. Open the "CC IE Field Configuration" window.

For the master/local module QJ71GF11-T2

Project window ⇒ [Parameter] ⇒ [Network Parameter] ⇒ [Ethernet/CC IE/MELSECNET] ⇒ [CC IE Field Configuration Setting] button

2. Select the I/O module in "List of stations" on the "CC IE Field Configuration" window.

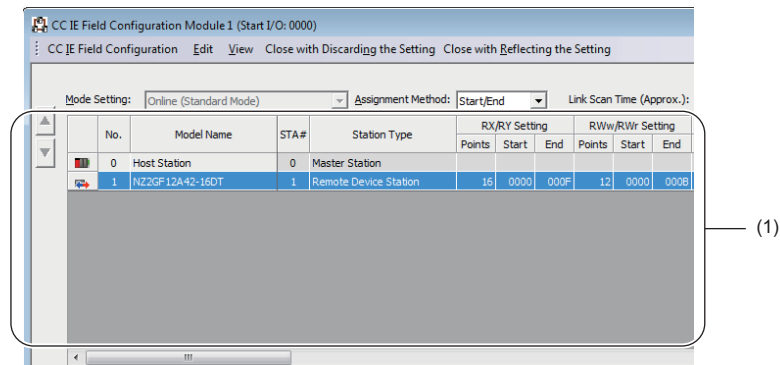

(1) List of stations

Point

The points of "RWw/RWr Setting" can be increased/decreased in increments of four points. Decreasing the points of "RWw/RWr Setting" shortens the link refresh time when some remote register areas are not used.

7

3. Open the "Parameter Processing of Slave Station" window.

[CC IE Field Configuration] ⇒ [Online] ⇒ [Parameter Processing of Slave Station]

4. Set "Method selection" to "Parameter write".

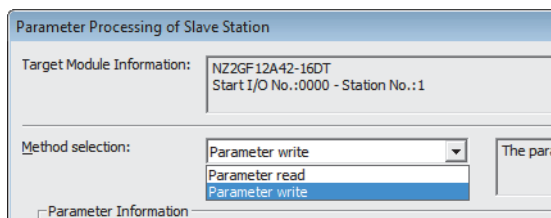

5. Double-click the item to change the setting, and input the setting value.

- Items to input from the pull-down list

Double-click the item to set, to display the pull-down list. Select the item.

- Items to input from the text box

Double-click the item to set, and input the setting value.

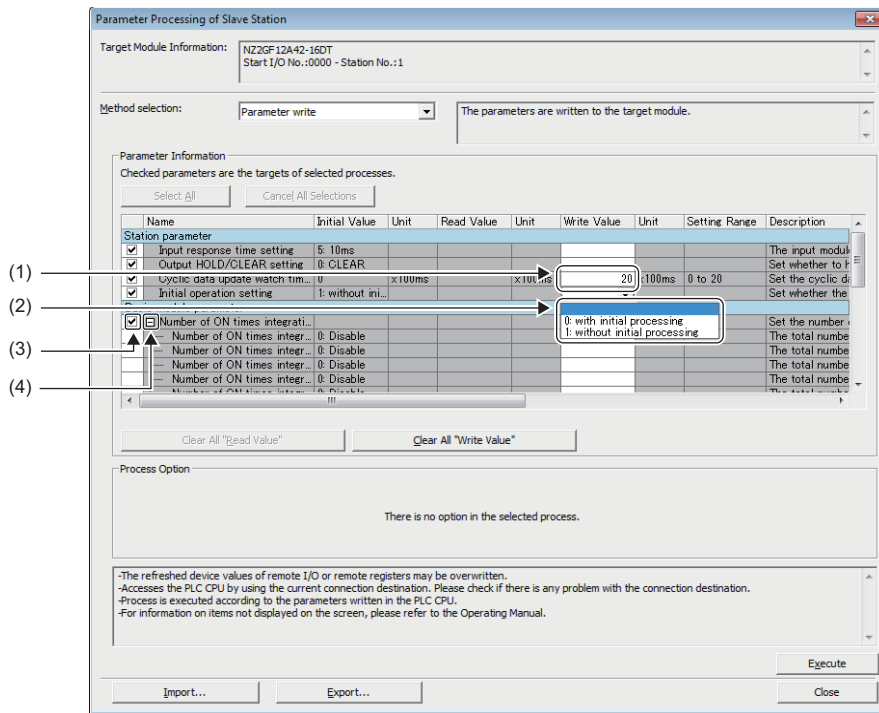

- (1) Items to input from the text box
- (2) Items to input from the drop-down list
- (3) The checkbox cannot be unchecked.
- (4) The list cannot be collapsed.

Module type	Setting item	Reference	
Input module	Input response time setting	Page 86 Input Response Time Setting Function	
	Initial operation setting	Page 98 Initial Operation Setting Function	
	Input OFF delay setting	Input OFF delay setting X0	Page 84 Input OFF Delay Function
		Input OFF delay setting X1	
		Input OFF delay setting X2	
		Input OFF delay setting X3	
		Input OFF delay setting X4	
		Input OFF delay setting X5	
		Input OFF delay setting X6	
		Input OFF delay setting X7	
		Input OFF delay setting X8	
		Input OFF delay setting X9	
		Input OFF delay setting XA	
		Input OFF delay setting XB	
		Input OFF delay setting XC	
Input OFF delay setting XD			
Input OFF delay setting XE			
Input OFF delay setting XF			

Module type	Setting item	Reference	
Output module	Output HOLD/CLEAR setting	Page 87 Output HOLD/ CLEAR Setting Function	
	Cyclic data update watch time setting	Page 88 Cyclic Data Update Watch Function	
	Initial operation setting	Page 98 Initial Operation Setting Function	
	Number of ON times integration function enable	Number of ON times integration function enable Y0	Page 89 Number of ON Times Integration Function
		Number of ON times integration function enable Y1	
		Number of ON times integration function enable Y2	
		Number of ON times integration function enable Y3	
		Number of ON times integration function enable Y4	
		Number of ON times integration function enable Y5	
		Number of ON times integration function enable Y6	
		Number of ON times integration function enable Y7	
		Number of ON times integration function enable Y8	
		Number of ON times integration function enable Y9	
		Number of ON times integration function enable YA	
		Number of ON times integration function enable YB	
I/O combined module	Input response time setting	Page 86 Input Response Time Setting Function	
	Output HOLD/CLEAR setting	Page 87 Output HOLD/ CLEAR Setting Function	
	Cyclic data update watch time setting	Page 88 Cyclic Data Update Watch Function	
	Initial operation setting	Page 98 Initial Operation Setting Function	
	Number of ON times integration function enable	Number of ON times integration function enable Y8	Page 89 Number of ON Times Integration Function
		Number of ON times integration function enable Y9	
		Number of ON times integration function enable YA	
		Number of ON times integration function enable YB	
		Number of ON times integration function enable YC	
		Number of ON times integration function enable YD	
Number of ON times integration function enable YE			
Input OFF delay setting	Input OFF delay setting X0	Page 84 Input OFF Delay Function	
	Input OFF delay setting X1		
	Input OFF delay setting X2		
	Input OFF delay setting X3		
	Input OFF delay setting X4		
	Input OFF delay setting X5		
	Input OFF delay setting X6		
	Input OFF delay setting X7		
Fast logic setting	Fast Logic Setting Y8	Page 95 Fast Logic Function	
	Fast Logic Setting Y9		
	Fast Logic Setting YA		
	Fast Logic Setting YB		

6. Click the [Execute] button and the following window is displayed.

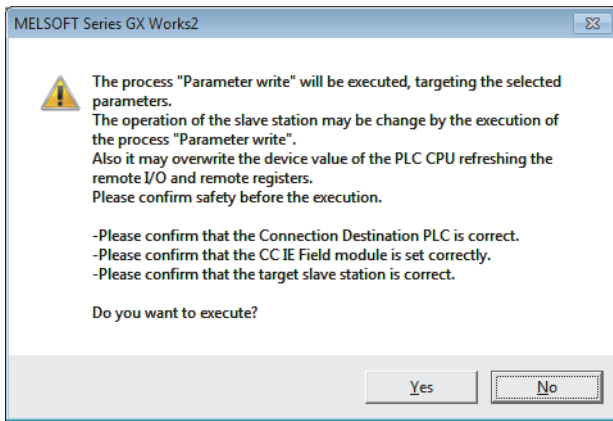

7. Click the [Yes] button.

8. The parameter is written to the I/O module.

Point

- Set all the items for the parameter. If any blank exists, the parameter cannot be written to the I/O module.
- To read the parameter from the I/O module, set "Method selection" to "Parameter read" and click the [Execute] button.
- When the following message is displayed, take corrective action for the error code in < >.

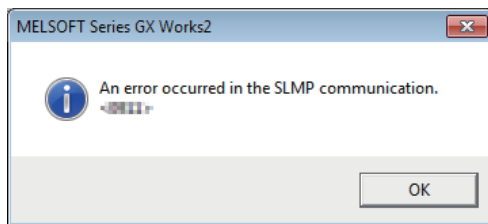

For details on the error code, refer to the following.

 Page 124 Error Code List

 User's manual for the master/local module used

7.2 Changing the Parameter

This section describes the procedure for changing the parameter.

The precautions for changing the parameter are the same as those in the following section.

☞ Page 72 Precautions

Changing the network configuration

When changing the network configuration diverting the created project, set the parameter in the following procedure.

1. Power off the module.
2. Connect the modules again according to the desired network configuration.
3. Power on the module.
4. Open the "CC IE Field Configuration" window.

For the master/local module QJ71GF11-T2

☞ Project window ⇒ [Parameter] ⇒ [Network Parameter] ⇒ [Ethernet/CC IE/MELSECNET] ⇒ [CC IE Field Configuration Setting] button

5. Drag and drop a module to set the slave station. Input a numerical value to set the station number of the station. Change the value as necessary.

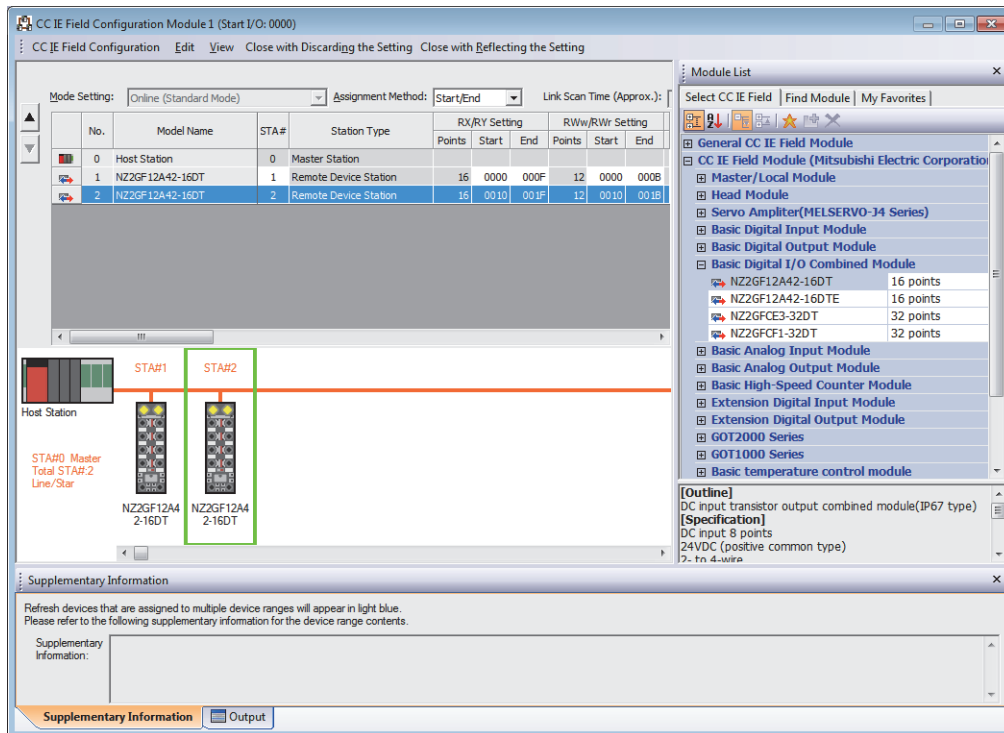

6. Close the "CC IE Field Configuration" window.

☞ [CC IE Field Configuration] ⇒ [Close with Reflecting the Setting]

7. Click the [Refresh Parameters] button to display the refresh parameter setting window.

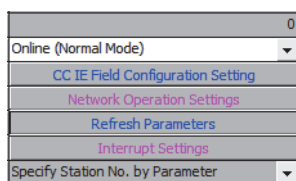

8. Set the refresh parameter. Change the value as necessary.

Assignment Method

Points/Start
 Start/End

	Link Side					PLC Side			
	Dev. Name	Points	Start	End		Dev. Name	Points	Start	End
Transfer SB	SB	512	0000	01FF	↔	SB	512	0000	01FF
Transfer SW	SW	512	0000	01FF	↔	SW	512	0000	01FF
Transfer 1	RX	32	0000	001F	↔	X	32	1000	101F
Transfer 2	RY	32	0000	001F	↔	Y	32	1000	101F
Transfer 3	RWr	24	0000	0017	↔	W	24	000100	000117
Transfer 4	RWw	24	0000	0017	↔	W	24	000200	000217
Transfer 5					↔				
Transfer 6					↔				
Transfer 7					↔				
Transfer 8					↔				

9. Write the set parameter to the CPU module of the master station and reset the CPU module.

10. Change the status of the CPU module of the master station to RUN.

The network configuration setting is now completed.

Changing the parameter without changing the network configuration

To change only the created module parameter of the slave station without changing the network configuration, set the parameter in the following procedure.

1. Open the "CC IE Field Configuration" window.

For the master/local module QJ71GF11-T2

Project window ⇒ [Parameter] ⇒ [Network Parameter] ⇒ [Ethernet/CC IE/MELSECNET] ⇒ [CC IE Field Configuration Setting] button

2. Select the I/O module in "List of stations" on the "CC IE Field Configuration" window.

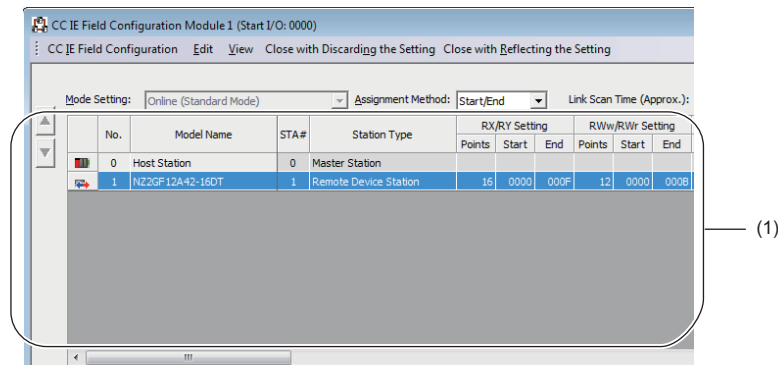

(1) List of stations

3. Open the "Parameter Processing of Slave Station" window.

[CC IE Field Configuration] ⇒ [Online] ⇒ [Parameter Processing of Slave Station]

4. Set "Method selection" to "Parameter read".

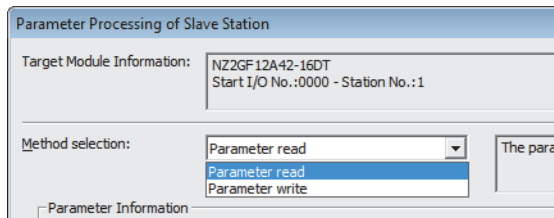

5. Click the [Execute] button and the following window is displayed.

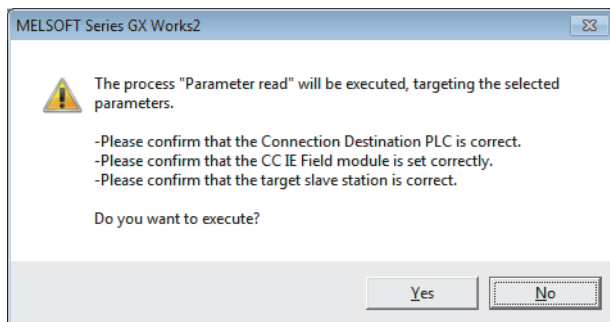

6. Click the [Yes] button.

7. The parameter is read from the I/O module.

Name	Initial Value	Unit	Read Value	Unit	Write Value	Unit
Station parameter						
<input checked="" type="checkbox"/> Input response time setting	5: 10ms		2: 1.0ms			
<input checked="" type="checkbox"/> Output HOLD/CLEAR setting	0: CLEAR		0: CLEAR			
<input checked="" type="checkbox"/> Cyclic data update watch tim...	0	x100ms	2	x100ms		x100ms
<input checked="" type="checkbox"/> Initial operation setting	1: without ini...		1: without ini...			
Basic module parameter						
<input checked="" type="checkbox"/> <input type="checkbox"/> Number of ON times integrati...						
..... Number of ON times integr...	0: Disable		0: Disable			
..... Number of ON times integr...	0: Disable		0: Disable			
..... Number of ON times integr...	0: Disable		0: Disable			
..... Number of ON times integr...	0: Disable		0: Disable			
..... Number of ON times integr...	0: Disable		0: Disable			

8. Set "Method selection" to "Parameter write".

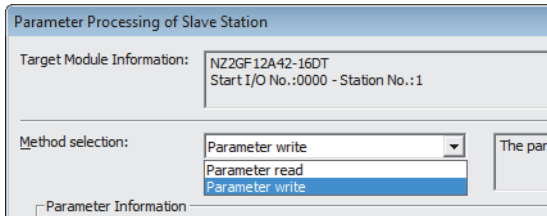

9. Set "Write Value". The following are the procedure.

- Click the title cell of "Read Value" to select all the items and copy them.
- Click the title cell of "Write Value" to select all the items and paste the copy.
- Select the items to be changed, and set new values.

Name	Initial Value	Unit	Read Value	Unit	Write Value	Unit
Station parameter						
<input checked="" type="checkbox"/> Input response time setting	5: 10ms		2: 1.0ms		2: 1.0ms	
<input checked="" type="checkbox"/> Output HOLD/CLEAR setting	0: CLEAR		0: CLEAR		0: CLEAR	
<input checked="" type="checkbox"/> Cyclic data update watch tim...	0	x100ms	2	x100ms	2	x100ms
<input checked="" type="checkbox"/> Initial operation setting	1: without ini...		1: without ini...		1: without ini...	
Basic module parameter						
<input checked="" type="checkbox"/> <input type="checkbox"/> Number of ON times integrati...						
..... Number of ON times integr...	0: Disable		0: Disable		0: Disable	
..... Number of ON times integr...	0: Disable		0: Disable		0: Disable	
..... Number of ON times integr...	0: Disable		0: Disable		0: Disable	
..... Number of ON times integr...	0: Disable		0: Disable		0: Disable	
..... Number of ON times integr...	0: Disable		0: Disable		0: Disable	

10. Click the [Execute] button and the following window is displayed.

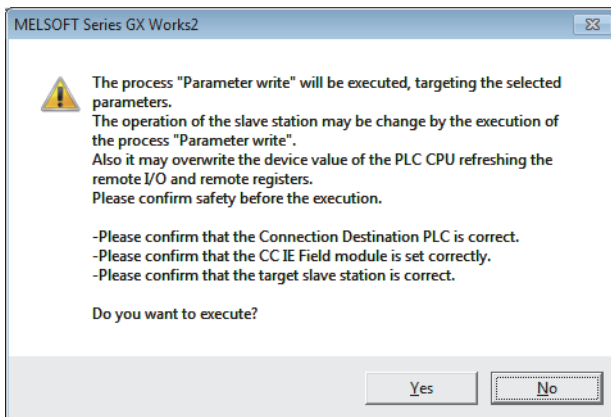

11. Click the [Yes] button.

12. The parameter is written to the I/O module.

The module parameter setting of the slave station is completed.

8 FUNCTIONS

This chapter describes the details of the functions available in the I/O module, and the setting procedures for those functions. For details on remote I/O signals, remote registers, and remote buffer memory, refer to the following.

☞ Page 143 Details of Remote I/O Signals

☞ Page 144 Details of Remote Registers

☞ Page 154 Details of Remote Buffer Memory Addresses

8.1 Error Notification Function

When an error or warning occurs, the I/O module notifies the master station of it using remote registers.

Point

The notification of the error or warning can be checked on the LED on the front of the module. For details, refer to the following.

☞ Page 17 LEDs on an I/O module

Notification of an error

The I/O module notifies the master station of an error in the following method.

Item	Description	Reference
Error status flag (RWr0.b10)	Turns on when a moderate error or major error occurs.	Page 147 Error status flag (RWr0.b10)
Error clear request flag (RWw0.b10)	Some errors can be cleared by turning on and off Error clear request flag (RWw0.b10).	Page 152 Error clear request flag (RWw0.b10)
Error code (RWr1)	An error code is stored when a moderate error or major error occurs.	Page 148 Error code

Point

Depending on the major error status such as a hardware failure of the module, Error status flag (RWr0.b10) may not be turned on, or an error code may not be stored in Error code (RWr1). When the above error occurs, check the error occurrence with the LED indication on the front of the module, and please consult your local Mitsubishi representative.

Method for clearing an error

The method for clearing an error depends on the error type.

Error type	Clearing an error
Major error	The error cannot be cleared.
Moderate error	Turn on Error clear request flag (RWw0.b10) or Operation condition setting request flag (RWw0.b9) after removing the error cause.

Notification of a warning

The I/O module notifies the master station of a warning in the following method.

Item	Description	Reference
Warning status flag (RWr0.b12)	Turns on when a minor error occurs.	Page 148 Warning status flag (RWr0.b12)
Warning code (RWr2)	The error code is stored when a minor error occurs.	Page 148 Warning code

Method for clearing a warning

Error type	Warning	Clearing an error
Minor error	Warning	A warning is cleared five seconds after the error cause is removed.

A warning results in the following state five seconds after the error cause is removed.

- Warning status flag (RWr0.b12) turns off.
- Warning code (RWr2) is cleared.
- The ERR. LED turns off.

Ex.

Operation to clear Station number switch changing error (error code: 0203H)

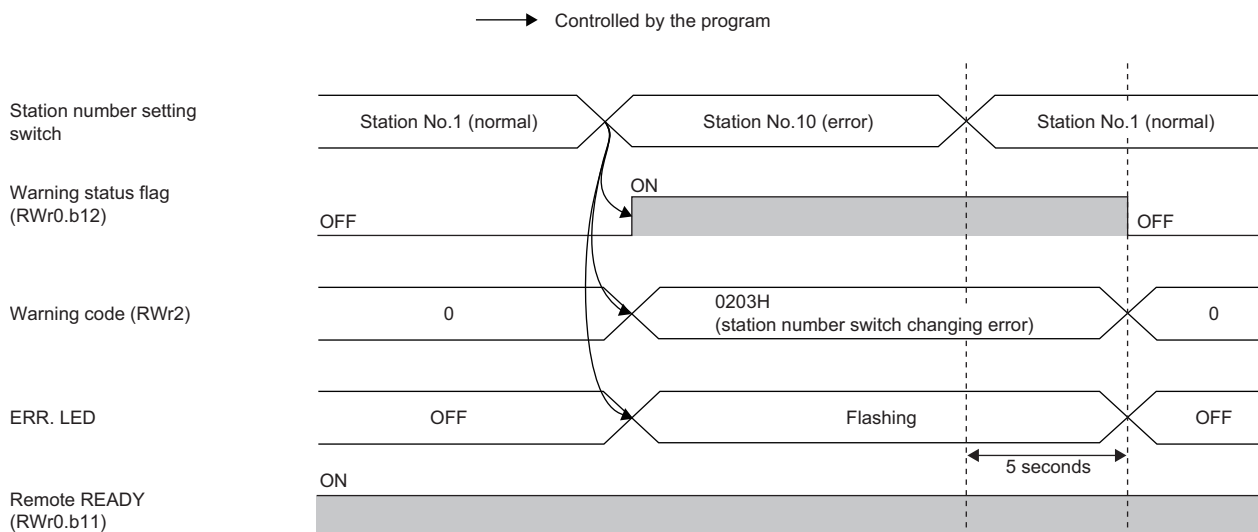

Method for clearing an error by executing the command of the slave station

The following shows how to clear an error by executing the command of the slave station.

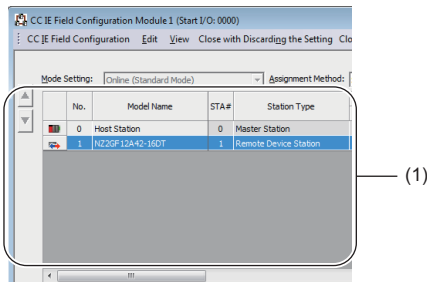

(1) List of stations

1. Select the I/O module in "List of stations" on the "CC IE Field Configuration" window.

2. Open the "Command Execution of Slave Station" window.

[CC IE Field Configuration] ⇒ [Online] ⇒ [Command Execution of Slave Station]

3. Set "Method selection" to "Error clear request" and click the [Execute] button.

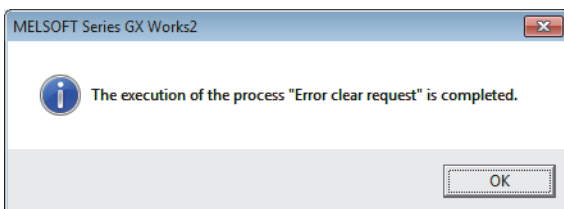
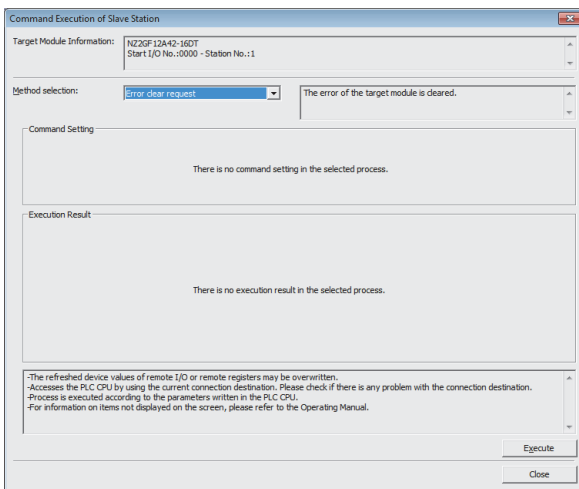

4. In the window that appears (shown left), click the [OK] button.

5. The error for the I/O module is cleared.

8.2 Input OFF Delay Function

This function turns off an X signal after a predetermined time passed from when an actual input becomes off from on. With the input OFF delay function, even an input whose ON time is extremely short can be surely recognized on a program. When an external input device is replaced with a sensitive one, users can use their previous program by only adjusting the delay time.

Set whether to enable or disable the function and set the delay time for each input point from the module parameter setting window of the engineering tool or the program.

Ex.

A short period of ON time can be surely recognized by setting the delay time longer than the period of the link scan time.

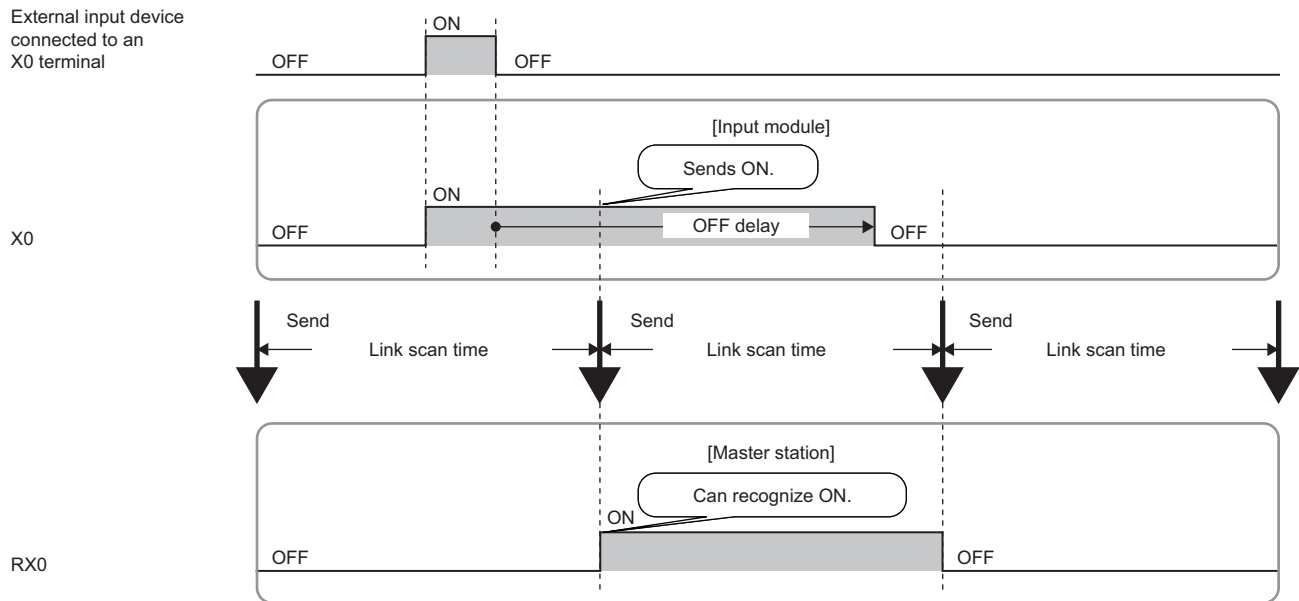

When the ON time of the target input signal is less than $100\mu\text{s}$, the module cannot recognize ON of the input and the input OFF delay function may not be performed.

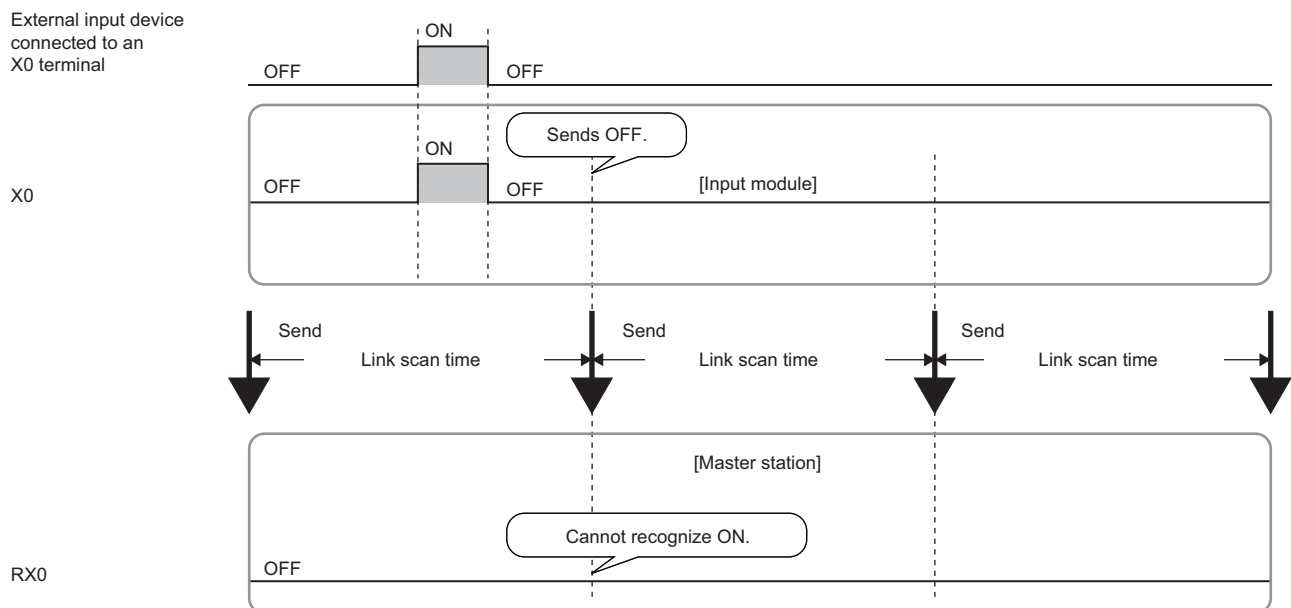

Point

- The delay time does not include the hardware response time.
- The accuracy of the delay time is 0 to $400\mu\text{s}$.

Setting procedure

1. Set "Method selection" to "Parameter write".

☞ "CC IE Field Configuration" window ⇒ Select an I/O module in "List of stations". ⇒ [CC IE Field Configuration] ⇒ [Online] ⇒ [Parameter Processing of Slave Station]

2. Set a delay time for "Input OFF delay setting X□".

<input checked="" type="checkbox"/>	Input OFF delay setting				
	Input OFF delay setting X0	0	x400us	x400us	2500
	Input OFF delay setting X1	0	x400us	x400us	

Setting item	Setting range
Input OFF delay setting X□ ^{*1}	<ul style="list-style-type: none"> • 0 (No delay) • 1 to 150000 (400μs to 60s, 400μs unit)

*1 Each module has the same item and setting range.

Combination of the input OFF delay function and the fast logic function

Ex.

An application that turns on a lamp for one second or longer responding to a brief turning on of the sensor input on the I/O combined module

- With the input OFF delay setting, an input signal (X4) turns off after one second (1000000μs).
- When the input signal (X4) is on, the output (YA) of the lamp is turned on.

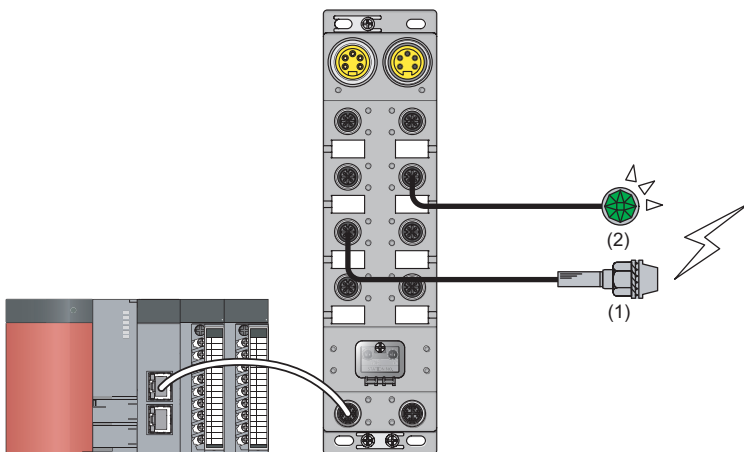

(1) Input signal (X4)
(2) Output (YA)

Item	Setting
Input OFF delay setting X4	2500
Fast Logic Setting YA	Enable

For the fast logic function, refer to the following.

☞ Page 95 Fast Logic Function

8.3 Input Response Time Setting Function

This function prevents an incorrect input due to noise by setting the response time until the module recognizes an actual input as the X signal.

The input response time can be set from the module parameter setting window of the engineering tool or the program.

Setting procedure

1. Set "Method selection" to "Parameter write".

 "CC IE Field Configuration" window ⇒ Select an I/O module in "List of stations". ⇒ [CC IE Field Configuration] ⇒ [Online] ⇒ [Parameter Processing of Slave Station]

2. For "Input response time setting", select the appropriate input response time.

<input checked="" type="checkbox"/>	Input response time setting	5: 10ms					
<input checked="" type="checkbox"/>	Output HOLD/CLEAR setting	0: CLEAR					
<input checked="" type="checkbox"/>	Cyclic data update watch tim...	0	x100ms		x100ms		
<input checked="" type="checkbox"/>	Initial operation setting	1: without ini...					
Basic module parameter							
<input checked="" type="checkbox"/>	<input type="checkbox"/> Number of ON times integrati...						
	Number of ON times integr...	0: Disable					
	Number of ON times integr...	0: Disable					
	Number of ON times integr...	0: Disable					

Item	Setting range
Input response time setting	0: 0ms 1: 0.5ms 2: 1.0ms 3: 1.5ms 4: 5ms 5: 10ms 6: 20ms 7: 70ms

Precautions

The input module may take in noise as an input depending on the input response time setting.

The pulse width which is taken in as an input varies depending on the input response time set in parameters.

To set the input response time, consider fully the operating environment.

The following table shows the minimum values of the pulse widths which may be taken in as an input. The pulse widths lower than the values shown below can be filtered as noise.

Value of input response time setting	0ms	0.5ms	1.0ms	1.5ms	5ms	10ms	20ms	70ms
The minimum value of the pulse width which may be taken in as an input (the maximum pulse widths which can be filtered as noise)	—	0.1ms	0.4ms	0.6ms	2ms	4.5ms	9ms	36ms

8.4 Output HOLD/CLEAR Setting Function

When the I/O module is disconnected from data link, or the CPU module operating status is STOP, whether to hold or clear the last output value can be set. Set whether to hold or clear the values for all the output points of the module in a batch from the module parameter setting window of the engineering tool or the program. The output HOLD/CLEAR setting is applied to a contact whose output is on by the fast logic function.

Output HOLD/CLEAR setting and its operation

When CLEAR or HOLD is set for an output, the output is turned on or off as follows.

Operating status		HOLD/CLEAR setting CLEAR (default)		HOLD/CLEAR setting HOLD	
		Last output status OFF	Last output status ON	Last output status OFF	Last output status ON
Data link in operation	CPU module in RUN	OFF	ON	OFF	ON
	CPU module in STOP	OFF	OFF	OFF	ON
	CPU module in PAUSE	OFF	ON	OFF	ON
	CPU module in RESET	OFF	OFF	OFF	ON
	CPU module suspended by error	OFF	OFF	OFF	ON
During disconnection/cyclic stop		OFF	OFF	OFF	ON

Setting procedure

1. Set "Method selection" to "Parameter write".

 "CC IE Field Configuration" window ⇒ Select an I/O module in "List of stations". ⇒ [CC IE Field Configuration] ⇒ [Online] ⇒ [Parameter Processing of Slave Station]

2. For "Output HOLD/CLEAR setting", select "0: CLEAR" or "1: HOLD".

Name	Initial Value	Unit	Read Value	Unit	Write Value
Station parameter					
<input checked="" type="checkbox"/> Input response time setting	5: 10ms				
<input checked="" type="checkbox"/> Output HOLD/CLEAR setting	0: CLEAR				
<input checked="" type="checkbox"/> Cyclic data update watch tim...	0	x100ms		x100ms	
<input checked="" type="checkbox"/> Initial operation setting	1: without ini...				0: CLEAR 1: HOLD
Basic module parameter					

Item	Setting range
Output HOLD/CLEAR setting	<ul style="list-style-type: none"> • 0: CLEAR • 1: HOLD

8.5 Cyclic Data Update Watch Function

The update intervals of cyclic data are monitored. The last output value is held or cleared when the cyclic transmission stop status continues longer than the set monitoring time.

The cyclic transmission stop status is the status that the D LINK LED is flashing (Data link in operation (cyclic transmission stopped)) or off (Data link not performed (disconnected)).

Set whether to hold or clear the output value using the output HOLD/CLEAR setting function. For the output HOLD/CLEAR setting function, refer to the following.

☞ Page 87 Output HOLD/CLEAR Setting Function

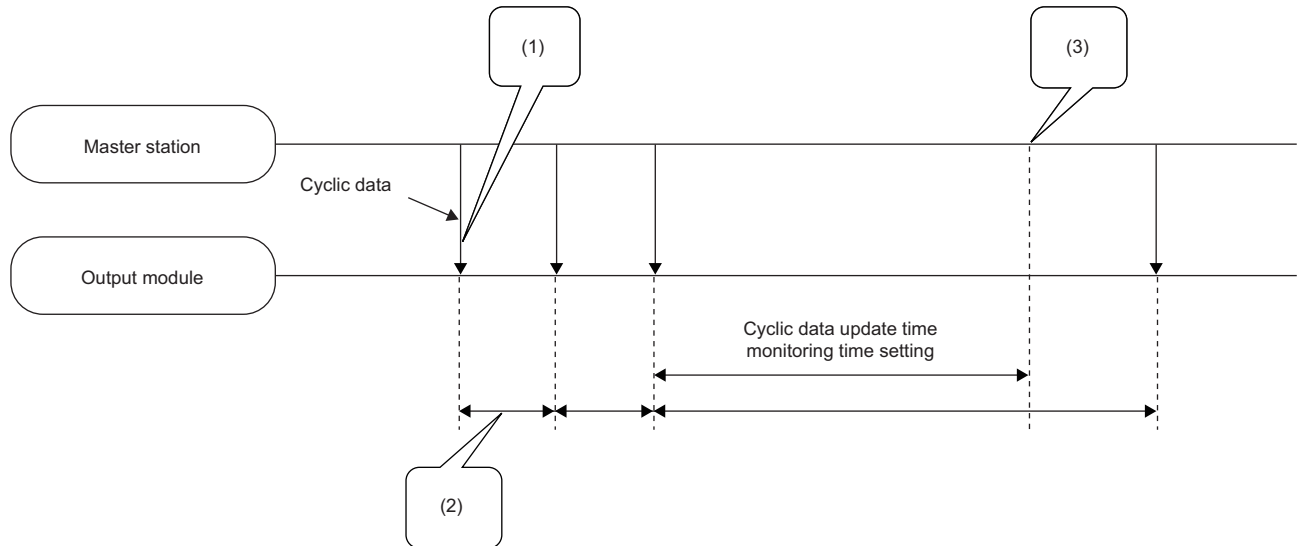

(1) Monitoring starts when the first cyclic data is received.

(2) The cyclic data is updated within the range of the data link update time.

(3) When the cyclic data update interval exceeds the set time, output is in the HOLD/CLEAR state.

Setting procedure

1. Set "Method selection" to "Parameter write".

☞ "CC IE Field Configuration" window ⇒ Select an I/O module in "List of stations". ⇒ [CC IE Field Configuration] ⇒ [Online] ⇒ [Parameter Processing of Slave Station]

2. Set the monitoring time in "Cyclic data update watch time setting".

Cyclic data update watch tim... 0 x100ms x100ms 20

Item	Setting range
Cyclic data update watch time setting	<ul style="list-style-type: none"> • 0 (Not monitor) • 1 to 20 (0.1 to 2 seconds in units of 100ms)

Point

Set the greater value for the cyclic data update watch time setting than that of the link scan time.

8.6 Number of ON Times Integration Function

The number of ON times of each output point is counted within the range of 0 to 2147483647. The integration value remains even though the output module is powered off. Whether to enable or disable the function can be set for each output point from the module parameter setting window of the engineering tool or the program. When the value for "Number of ON times integration function enable" is "1: Enable", the number of ON times at the corresponding output point is counted. When "0: Disable" is set, the number of ON times at the corresponding output point is not counted.

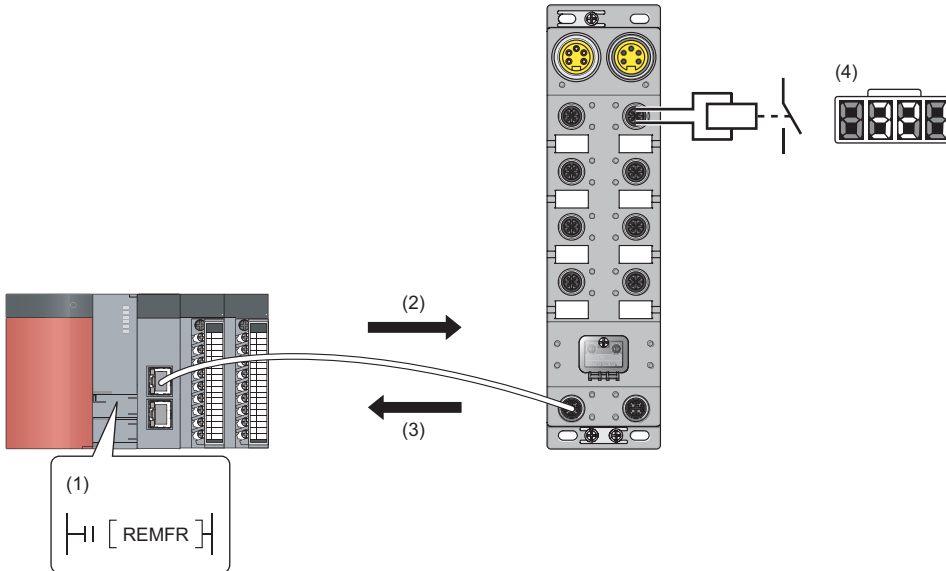

- (1) Read request (REMFR instruction)
- (2) Transient communication (read request)
- (3) Transient communication (number of ON times)
- (4) The number of ON times of Y_n is counted inside the module.

Setting procedure

1. Set "Method selection" to "Parameter write".

 "CC IE Field Configuration" window ⇒ Select an I/O module in "List of stations". ⇒ [CC IE Field Configuration] ⇒ [Online] ⇒ [Parameter Processing of Slave Station]

2. Set whether to enable or disable the number of ON times integration function in "Number of ON times integration function enable".

Number of ON times integration function enable Y8	0: Disable								
Number of ON times integration function enable Y9	0: Disable								
Number of ON times integration function enable YA	0: Disable								
Number of ON times integration function enable YB	0: Disable								

Item	Setting range
Number of ON times integration function enable Y□ ^{*1}	<ul style="list-style-type: none"> • 0: Disable • 1: Enable

*1 Each module has the same item and setting range.

Checking and clearing the number of ON times

The number of ON times can be checked and cleared on the program.

Item	Description	Reference
Number of ON times integration value Y□ (address: 0610H to 062FH)	Stores the integration value of the number of ON times integration function.	Program example <ul style="list-style-type: none"> • Page 104 Program Example Details of Remote Buffer Memory Addresses • Page 158 Number of ON times integration value
Number of ON times integration value clear command (address: 1100H)	When the corresponding bit of output is turned on, the integration value for the output with the number of ON times integration function is cleared to zero.	Program example <ul style="list-style-type: none"> • Page 111 Program example for clearing the number of ON times Details of Remote Buffer Memory Addresses • Page 164 Number of ON times integration value clear command
Number of ON times integration value clear completed (address: 1101H)	After the integration value is cleared to zero using Number of ON times integration value clear command (address: 1100H), the bit of the output which is cleared to zero turns on.	Program example <ul style="list-style-type: none"> • Page 111 Program example for clearing the number of ON times Details of Remote Buffer Memory Addresses • Page 165 Number of ON times integration value clear completed

Point

- When the ON time and the OFF time of the target output signal are less than 10ms, the output module cannot recognize the output change and the number of ON times may not be counted.
- When the number of ON times integration value exceeds 2147483647, the count stops. To integrate the number of ON times continuously, clear the integration value by using Number of ON times integration value clear command (address: 1100H).
- The number of ON times is counted also when the fast logic function is enabled.

8.7 Output ON/OFF Information Hold Function

This function checks if the output has been turned once on or off.

Output ON information

Output ON information is stored in Output Y ON information (RWr7).

Whether the output has been turned on or not can be checked with Output Y ON information (RWr7).

Output Y ON information (RWr7) can be cleared using Output Y ON information clear request (RWw7).

For the on and off timing, refer to the following.

☞ Page 150 Output Y ON information

Output OFF information

Output OFF information is stored in Output Y OFF information (RWr8).

Whether the output has been turned off or not can be checked with Output Y OFF information (RWr8).

Output Y OFF information (RWr8) can be cleared using Output Y OFF information clear request (RWw8).

For the on and off timing, refer to the following.

☞ Page 151 Output Y OFF information

8.8 Power Supply Monitoring Function

This function monitors the voltage status of each of the module-and-sensor power supply and load power supply and notifies users of the status with the PW LED and L PW LED.

By using Power supply monitor request flag (RWw3.b0), a moderate error is generated when the power supply is off. Thus, the on/off state of the power supply is notified and the output module can be stopped.

Point

Enabling the power supply monitoring function is recommended because operating the module with the power supply voltage unstable may cause incorrect input or output.

Operation of the power supply monitoring function

When an error occurs on the module-and-sensor power supply or load power supply while the Power supply monitor request flag (RWw3.b0) is on, a moderate error occurs. The following table lists errors of each power supply and bits to be turned on.

Error cause		Error code	
Abnormal power supply	Description		
Module-and-sensor power supply	Low voltage	0103H	Bit 0 of Error code details 1 turns on.
	Overvoltage		Bit 1 of Error code details 1 turns on.
Load power supply	Low voltage		Bit 2 of Error code details 1 turns on.
	Overvoltage		Bit 3 of Error code details 1 turns on.

When using this function, check that the load power supply stabilizes before turning on Power supply monitor request flag (RWw3.b0). When turning off the load power supply, turn off Power supply monitor request flag (RWw3.b0) in advance.

Setting and checking the power supply monitoring function

Item	Description	Reference
Power supply monitor request flag (RWw3.b0)	Sets whether to enable or disable the power supply monitoring function.	Page 152 Power supply monitor request flag (RWw3.b0)
Power supply monitor state flag (RWr3.b0)	Indicates whether the power supply monitoring function is enabled or disabled.	Page 149 Power supply monitor state flag (RWr3.b0)

8.9 Short-Circuit Detection Function

This function detects a short circuit in each of input ports and output channels.

Short-circuit detection on each input port

A short circuit of the sensor power supply is detected in each of input ports.

■Operation overview

A short circuit is detected when the sensor power supply current exceeds the judgment value. Since a supply current is shared with two sensor power supplies in a port, a short-circuit in either one or both of the two sensor power supplies is detected. The current flowing through the sensor power supply of the port where a short circuit has been detected stops.

■Judgment value for short-circuit detection

A supply current to a set of two sensor power supplies (total current of the two sensor power supplies) is 400mA or more.

■Notification of a detected short-circuit

When a short circuit is detected in a set of two sensor power supplies, the following operation is performed.

- The LEDs of the two sensor power supplies in the port turn on in red.
- The corresponding bit of Input X port status (RWr4)*1 turns on.

Ex.

When a short circuit is detected in the port for X0 and X1 inputs of the NZ2GF12A4-16D with a 4-wire sensor connected

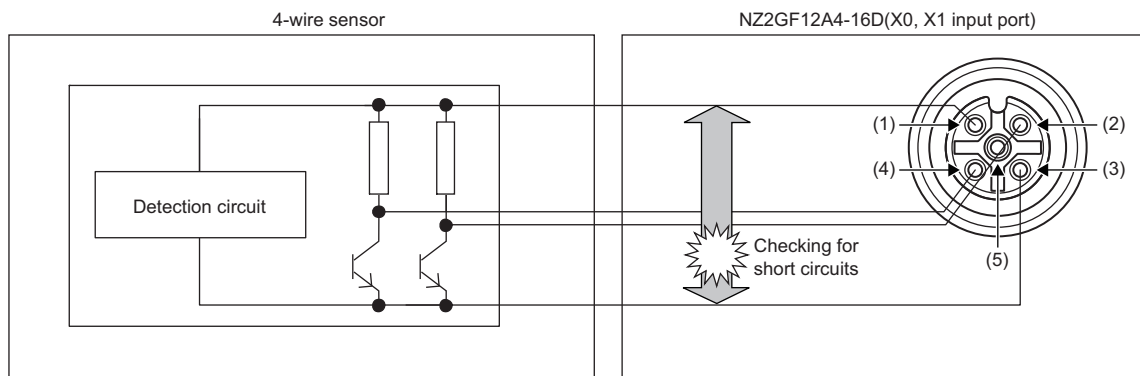

Pin number	Signal name
(1)	+24V (UNIT)
(2)	X1
(3)	24G (UNIT)
(4)	X0
(5)	FG

For example, when a short circuit is detected in X0, both the X0 LED and X1 LED turn on in red because X0 and X1 share the same port. The bit 0 (PS0) of Input X port status (RWr4) turns on.

■When a short circuit is eliminated

After a short circuit in a set of two sensor power supplies is eliminated and the two sensor power supplies in the port return to their normal conditions, the following operation will be performed.

- The LEDs of the two sensor power supplies in the port turn on in green.
- The corresponding bit of Input X port status (RWr4)*1 turns off.

*1 For details, refer to the following.

☞ Page 149 Input X port status

Short-circuit detection per output channel

A short circuit of an output signal is detected in each of output channels.

■Operation overview

A short circuit is detected when the output current of an output signal exceeds the judgment value.

■Judgment value for short-circuit detection

An output current is 6.5A or more (judged by each output signal).

■Notification of a detected short-circuit

When a short circuit is detected in an output signal, the following operation is performed.

- The LED corresponding to the output signal turns on in red.
- The corresponding bit of Output Y channel status (RWr5)^{*1} turns on.

Ex.

Short-circuit detection in the port for Y8 and Y9 outputs of the NZ2GF12A2-16T

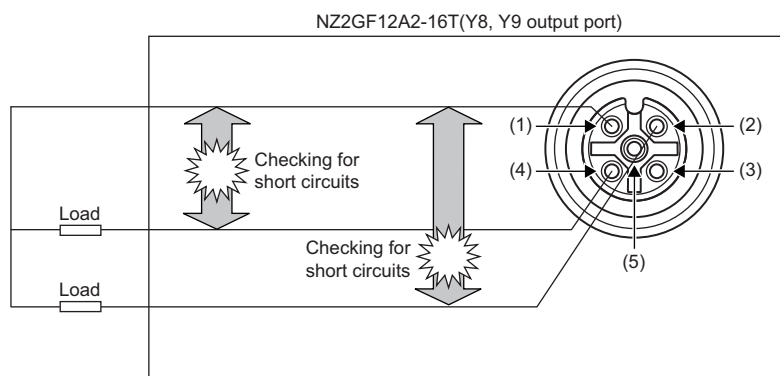

Pin number	Signal name
(1)	+24V (LOAD)
(2)	Y9
(3)	Empty
(4)	Y8
(5)	FG

For example, when a short circuit is detected in Y8, the Y8 LED turns on in red. The bit 8 (CS8) of Output Y channel status (RWr5) turns on.

■When a short circuit is eliminated

When a short circuit in an output signal is eliminated, the following operation is performed.

- The LED corresponding to the output signal turns on in green.
- The corresponding bit of Output Y channel status (RWr5)^{*1} turns off.

*1 For details, refer to the following.

☞ Page 149 Output Y channel status

8.10 Fast Logic Function

This function controls outputs according to the input status inside the I/O combined module without communications with the master station. High-speed output control can be performed with this function.

Set whether to enable or disable the function for each output point from the module parameter setting window of the engineering tool or the program. For the safety at module configuration change, the set parameter data returns to the default value (Disable (0)) when the module is powered off. (The parameter data is not stored to the nonvolatile memory.) To keep the set data, design a program which writes the value for the function at every module power supply on. For the program example, refer to the following.

☞ Page 114 Program example for the fast logic function

Overview of the fast logic function

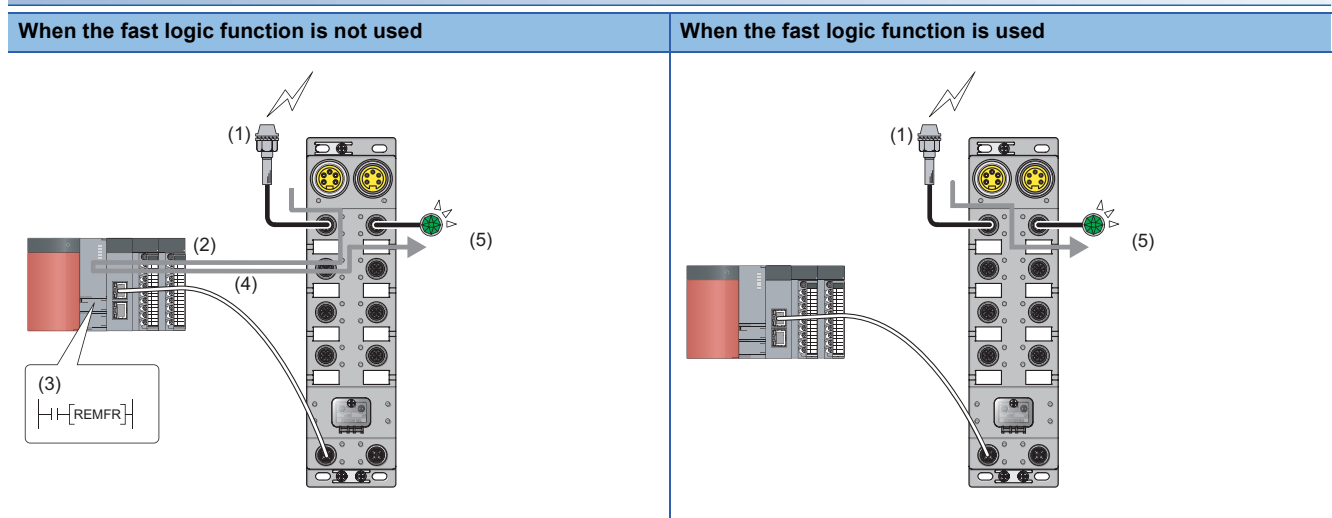

- (1) An input is changed.
- (2) The input status is sent.
- (3) CPU module processing (program)
- (4) An output instruction is received.
- (5) An output is changed.

Setting the fast logic function

In the fast logic setting, the combination of input signal A and B, and their output conditions for each output signal is fixed. When the input OFF delay function is used, a fast logic output is executed using the X signal for which the input OFF delay process has been executed.

■Combinations of output conditions and input signals for each output signal

- X0 to X7: Input signals of the I/O combined module
- Y8 to YB: Output signals of the I/O combined module

Item	Logic (output condition)	Output signal Y□	Input signal A	Input signal B
Fast logic setting Y8	AND (When both the input signal A and B turn on, Output signal Y□ is output.)	Y8	X0	X1
Fast logic setting Y9		Y9	X2	X3
Fast logic setting YA	OR (When either of the input signal A or B turns on, Output signal Y□ is output.)	YA	X4	X5
Fast logic setting YB		YB	X6	X7

Setting procedure

1. Set "Method selection" to "Parameter write".

 "CC IE Field Configuration" window ⇒ Select an I/O module in "List of stations". ⇒ [CC IE Field Configuration] ⇒ [Online] ⇒ [Parameter Processing of Slave Station]

2. Set whether to enable or disable the fast logic function in "Fast logic setting Y□".

<input checked="" type="checkbox"/>	Fast logic setting						
<input type="checkbox"/>	Fast Logic Setting Y8	0: Disable					
<input type="checkbox"/>	Fast Logic Setting Y9	0: Disable					
<input type="checkbox"/>	Fast Logic Setting YA	0: Disable					
<input type="checkbox"/>	Fast Logic Setting YB	0: Disable					0: Disable 1: Enable

Item	Setting range
Fast logic setting Y□*1	<ul style="list-style-type: none"> • 0: Disable • 1: Enable

*1 Each module has the same item and setting range.

Response time with the fast logic function

The following determines the total response time of the fast logic function from input to output.

Input response time + Response time of the fast logic function + Output response time

Input response time, output response time: Refer to the following.

 Page 20 I/O Module Specifications

Response time of the fast logic function:

- Without the input OFF delay function: 200 μ s
- With the input OFF delay function: 300 μ s

Ex.

The following determines the total response time including I/O with the fast logic function under the condition that the value of the input response time setting is 1.0ms, the fast logic function is used, and the input OFF delay function is not used.

Input response time (1.0ms) + Response time of the fast logic function (0.2ms) + Output response time (OFF \rightarrow ON) (0.5ms)
= 1.7ms

Checking the fast logic function enable status and output

Item	Description	Reference
Fast logic enable status (address: 0602H)	Stores the fast logic enable or disable status for each signal.	<ul style="list-style-type: none"> • Program example Page 117 Program example for checking the fast logic enable or disable status • Details of Remote Buffer Memory Addresses Page 157 Fast logic enable status
Output Y current value (RWr6)	Stores ON or OFF status of each output. A control result of the fast logic function can be checked.	Page 150 Output Y current value

Point

The I/O response performance of the fast logic function (the time between inputting the condition and updating an output) is 200 μ s or less (when one I/O combined module is used and the input OFF delay function is not used).

8.11 Initial Operation Setting Function

This function sets whether the initial processing using the program is necessary or not when the data link is established. The function enables the I/O module to operate (enabling the update of external I/O) with the program for initial processing not being set.

Operations of when the initial operation setting function is used

The operations of when the initial operation setting function is used vary depending on the setting value of "Initial operation setting". When setting parameters using Initial processing request flag (RWr0.b8) as an interlock as shown in the program example, set "Initial operation setting" to "0: with initial processing".

For program examples of initial processing, refer to the following.

☞ Page 116 Program example

■When "0: With initial processing" is set

When the data link is established, Initial processing request flag (RWr0.b8) turns on.

When Initial processing completion flag (RWw0.b8) is turned on, Initial processing request flag (RWr0.b8) turns off and Remote READY (RWr0.b11) turns on.

The external I/O function of the I/O module cannot be used until initial processing is completed.

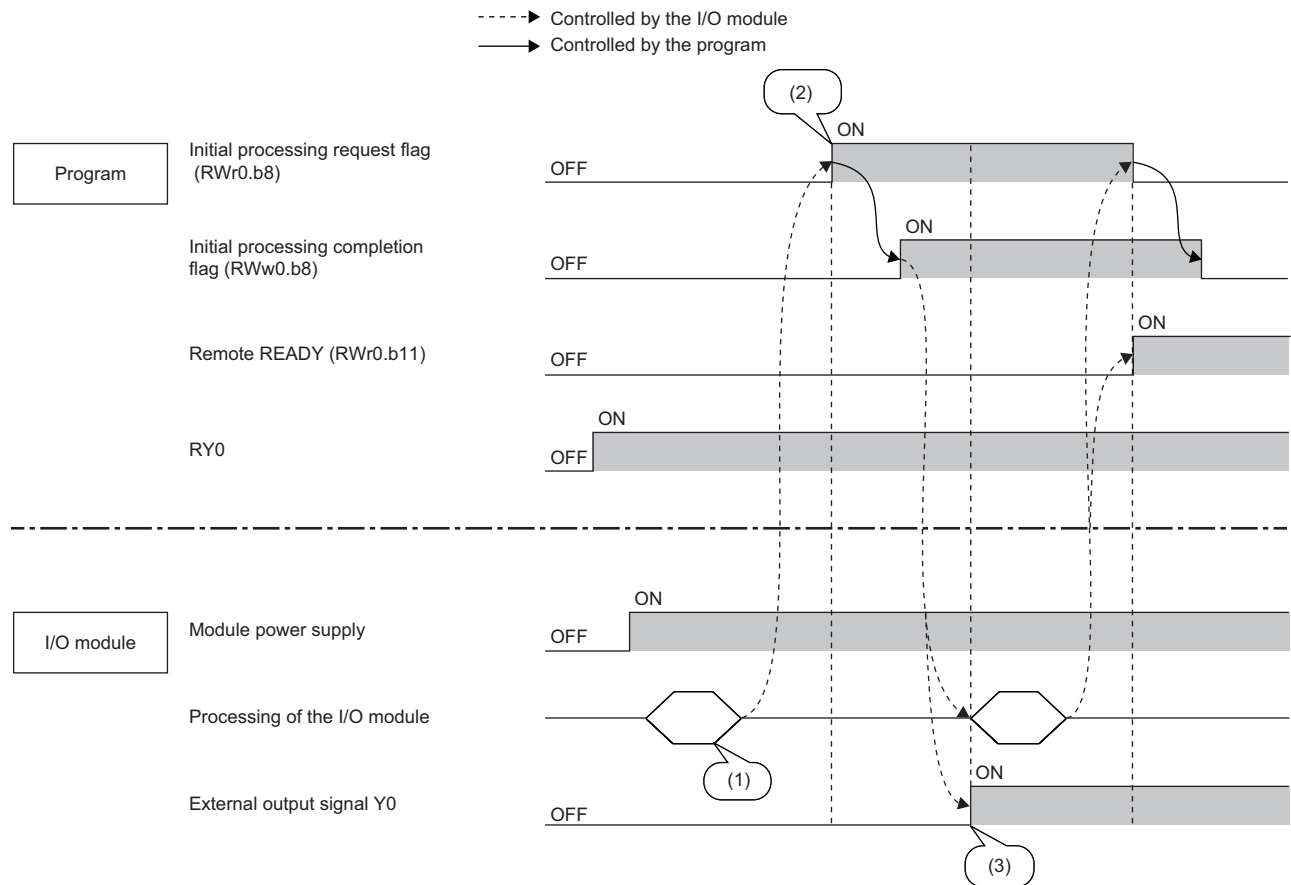

- (1) Processing executed at the startup
- (2) Data link is established.
- (3) The output is turned on.

When "1: Without initial processing" is set

- When the data link is established, Remote READY (RWr0.b11) turns on.
- At the data link establishment, the external I/O function of the I/O module becomes enabled.

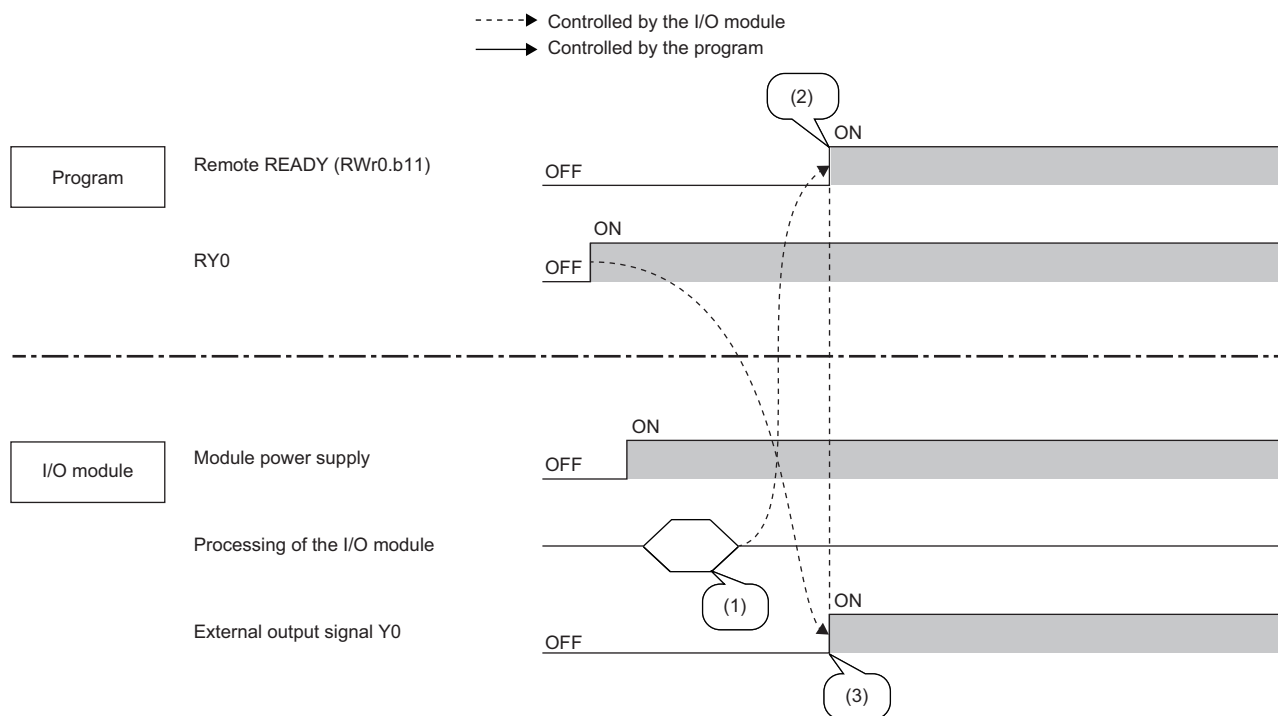

- (1) Processing executed at the startup
- (2) Data link is established.
- (3) The output is turned on.

Setting procedure

1. Set "Method selection" to "Parameter write".

"CC IE Field Configuration" window ⇒ Select an I/O module in "List of stations". ⇒ [CC IE Field Configuration] ⇒ [Online] ⇒ [Parameter Processing of Slave Station]

2. Set "Initial operation setting" to "0: With initial processing" or "1: Without initial processing".

<input checked="" type="checkbox"/>	Initial operation setting	1: without initial processing						
Basic module parameter								
<input checked="" type="checkbox"/>	Number of ON times integration f...							0: with initial processing 1: without initial processing
	Number of ON times integration...	0: Disable						

Item	Setting range
Initial operation setting	<ul style="list-style-type: none"> • 0: With initial processing • 1: Without initial processing

Point

When using the fast logic function, set parameters from a program at the startup of the I/O module. In such case, set "Initial operation setting" to "0: with initial processing".

8.12 Protection Function

The I/O module has the following protection functions.

○: Available, —: Not available

Protection function	Input module	Output module	I/O combined module
Overload protection function	—	○	○
Overheat protection function	—	○	○
Power supply overvoltage protection function	○	○	○

Point

The protection functions do not protect external devices but protect the internal circuit of the module. A problem on a load may raise the internal temperature of the module, causing deterioration in output elements and discoloration on the case and the printed-circuit board. Turn off the corresponding output as soon as a problem on a load is found, and remove the cause.

The following describes the operation of each protection function.

Overload protection function

If the output module and I/O combined module detect overcurrent, the module performs the current limiting operation (that imposes a limit on the output current to a constant value and keeps the output).

For the overcurrent detection value and the limited current, refer to "Overload protection function" in the specifications table for each module.

☞ Page 26 Output module

☞ Page 34 I/O combined module

If the load current becomes equal to the overcurrent detection value or lower, the module returns to normal operation.

Overheat protection function

If the output module and I/O combined module keep outputting the overcurrent caused by an overload, heat is generated inside the module. If the module detects a high heat in its inside, it turns off the output.

The multiple points at which the overheat protection function operates simultaneously depend on the module. Refer to "Overheat protection function" in the specifications table for each module.

☞ Page 26 Output module

☞ Page 34 I/O combined module

If the heat descends, the module automatically returns to normal operation.

Power supply overvoltage protection function

If the module power supply of the I/O module becomes the overvoltage state, the module stops the operation.

If the voltage of the module power supply descends, the module automatically returns to normal operation.

8.13 CC-Link IE Field Network Diagnostic Function

This function allows the presence or absence of a network error to be checked by accessing the engineering tool connected to the CPU module.

How to use

The following instructions assume the use of GX Works2 as the engineering tool.

1. Connect GX Works2 to the CPU module.

2. Start CC-Link IE Field Network diagnostics from the menu of GX Works2.

[Diagnostics] ⇒ [CC IE Field Diagnostics]

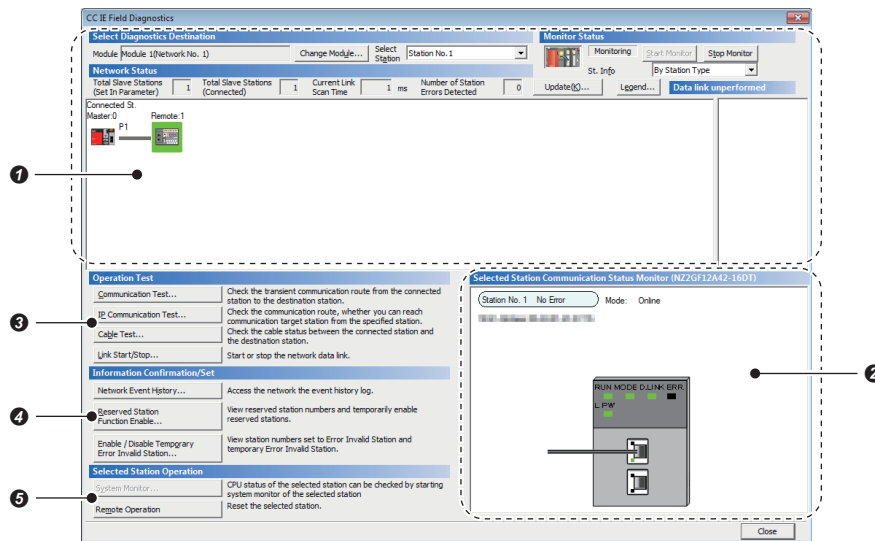

Item to be diagnosed	Description	Reference	
1	Display of network configuration diagram and error status	The status of the CC-Link IE Field Network can be checked. When an error or warning for the I/O module occurs, the status of the station is displayed on an icon.	User's manual for the master/local module used
2	Display of selected-station status and error details	The communication status of the station selected in "Networks Status" can be checked. "Selected Station Communication Status Monitor", which appears at the bottom right in the window, indicates the communication status of the I/O module.*1 For the error and warning for the I/O module, refer to the following. ☞ Page 121 Checking for the Error Codes and the Warning Codes	
3	Communication Test	The transient communication route and whether the communication is established from the connected station to the destination station can be checked.	
	IP Communication Test	The reaching time and the route of the IP communication from the connected station to the target station can be checked.	
	Cable Test	The cable status between the connected station and the destination station can be checked.	
	Link Start/Stop	The network data link can be started or stopped.	
4	Network Event History	The history of various events that occurred in the network can be checked.	
	Reserved Station Function Enable	A reservation for a station can be temporarily cancelled, and the cancellation can be disabled. Also, the station numbers for the modules set as reserved stations can be checked on a list.	
	Enable/Disable Ignore Station Errors	A station not set as an error invalid station can be temporarily set as an error invalid station, and the error invalid station setting can be disabled. Also, the station numbers for the modules set as (temporarily) error invalid stations can be checked on a list.	
5	System monitor	The system monitor on the selected station is activated and the status of the module can be checked. This function is unavailable for the I/O module.	
	Remote Operation	The selected station can be reset through the remote operation.	Page 102 Remote operation

*1 When the load power supply has a voltage error, the L PW LED status in "Selected Station Communication Status Monitor" may not be displayed correctly.

Point

Some of items cannot be diagnosed depending on the master/local module or the simple motion module used.

For details, refer to the following.

📖 User's manual for the master/local module used

📖 MELSEC-Q QD77GF Simple Motion Module User's Manual (Network)

Remote operation

1. Select a slave station to be reset and click the [Remote Operation] button.

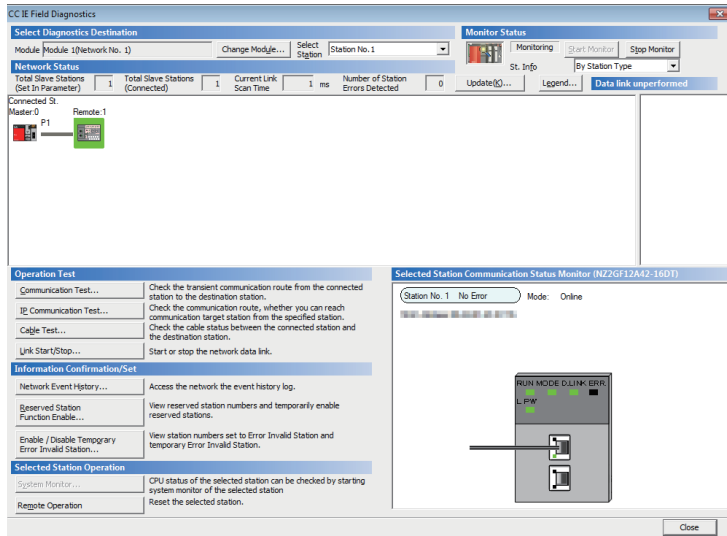

2. Clicking the [Yes] button on the following window starts the remote reset.

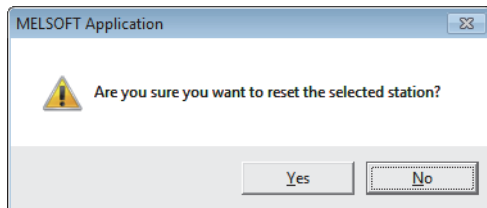

3. Click the [OK] button on the following window.

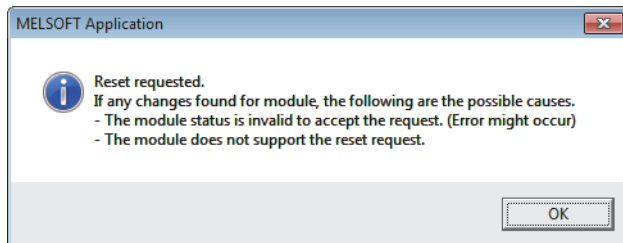

9 PROGRAMMING

This chapter describes the programming of the I/O module.

9.1 Precautions for Programming

This section describes precautions to create CC-Link IE Field Network programs.

Cyclic transmission program

For a cyclic transmission program, interlock with the following link special relay (SB) and link special register (SW).

- Own station data link status (master station) (SB0049)
- Data link status (each station) (SW00B0 to SW00B7)

For details on the link special relay (SB) and link special register (SW), refer to the user's manual for the master/local module used.

Ex.

Interlock example

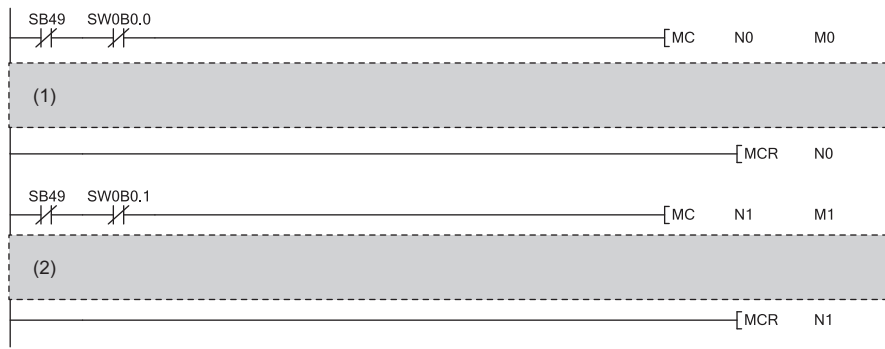

- (1) Communication program with station No.1
- (2) Communication program with station No.2

Transient transmission program

For a transient transmission program, interlock with the following link special relay (SB) and link special register (SW).

- Own station baton pass status (master station) (SB0047)
- Baton pass status (each station) (SW00A0 to SW00A7)

For details on the link special relay (SB) and link special register (SW), refer to the user's manual for the master/local module used.

Ex.

Interlock example



- (1) Start contact
- (2) Dedicated instruction to station No.1

9.2 Procedure for Programming

Create a program to execute each function of the I/O module, according to the following procedure.

1. Parameter setting

☞ Page 72 Parameter Setting

2. Creating an auxiliary program (error reset program)*1

*1 A program added depending on control details (Create the program as necessary.)

9.3 Program Example

System configuration

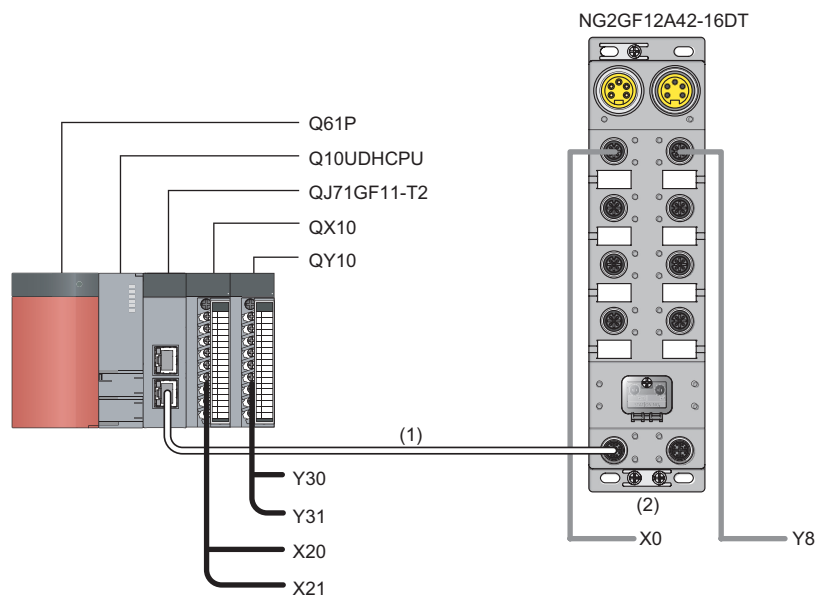

(1) Network No.1

(2) Station No.1



The setting procedure assumes the use of GX Works2 as the engineering tool.

■Assignment of link devices

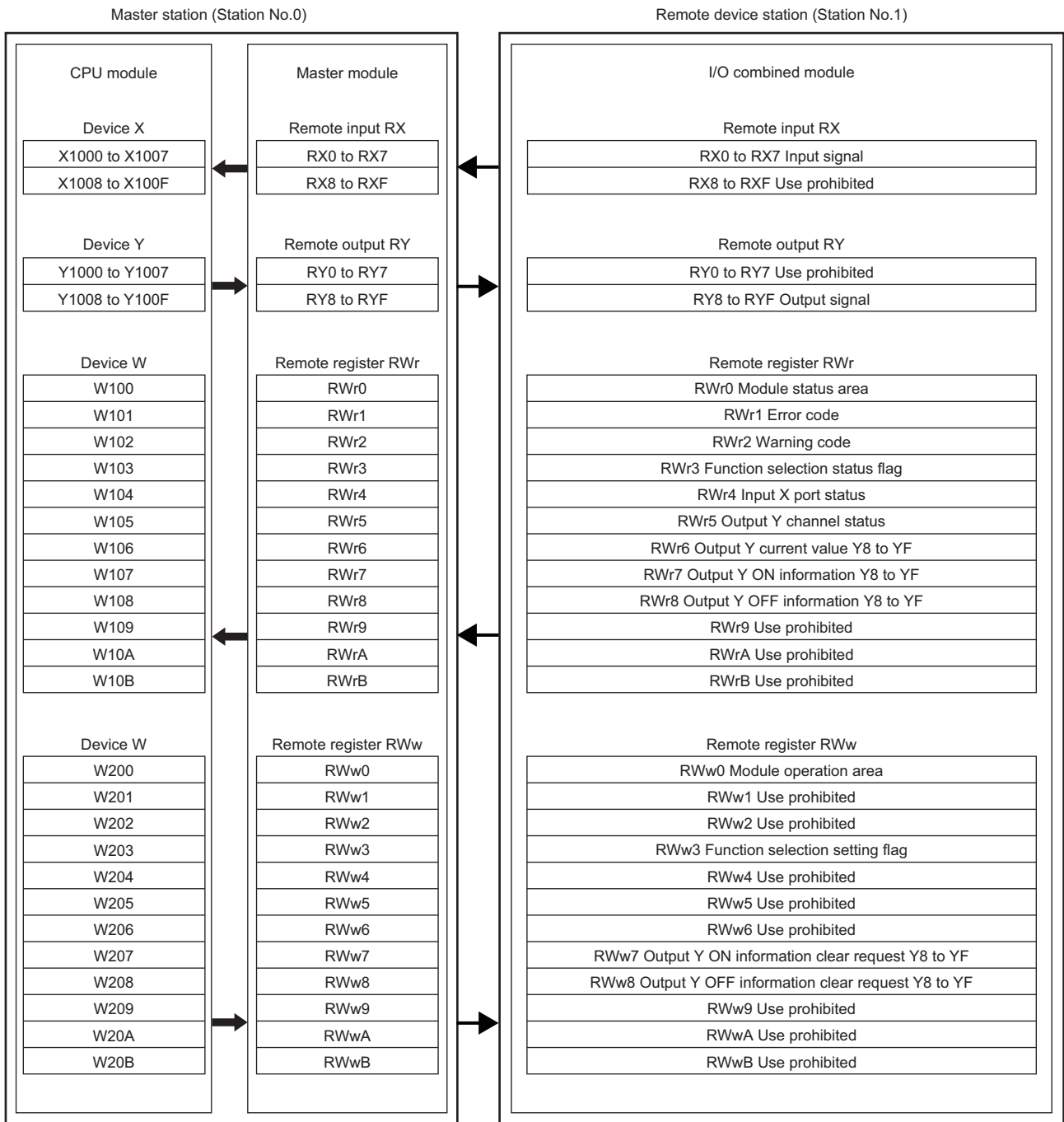

Programming condition

When X0 of the I/O combined module turns on, Y8 is turned on.

The number of ON times of the I/O combined module is read.

When an error or a warning occurs, an output module (QY10) outputs a digital signal.

Initial setting description

The following table lists the initial settings of the I/O combined module.

Item	Description
Input response time setting	1.0ms
Output HOLD/CLEAR setting	CLEAR
Cyclic data update watch time setting	200ms
Initial operation setting	Without initial processing
Input OFF delay setting X0 to X7	0
Number of ON times integration function enable Y8 to YF	Enable
Fast logic setting Y8 to YB	Disable

Devices used by user

Device	Description	
X20	Error clear switch	QX10 (X20 to X2F)
X21	Number of ON times read switch	
X1000	X0 input signal (push-button switch) of the I/O combined module	NZGF12A42-16DT (X1000 to X1007)
Y1008	Y8 output signal (lamp) of the I/O combined module	
Y30	Error lamp	QY10 (Y30 to Y3F)
Y31	Warning lamp	
D100	Latest error code	
D101	Latest warning code	
D110 to D125	Number of ON times (Y8 to YF)	
M0	Contact for master control	
M14 to M17	Contact for reading the number of ON times	
N0	Nesting	
SB47	Own station baton pass status (master station)	
SB49	Own station data link status (master station)	
SM400	Always ON	
SW0A0.0	Baton pass status (station No.1)	
SW0B0.0	Data link status (station No.1)	
W100.A	Error status flag (RWr0.b10)	Device to be written by link refresh
W100.B	Remote READY (RWr0.b11)	
W100.C	Warning status flag (RWr0.b12)	
W200.A	Error clear request flag (RWw0.b10)	
W101	Latest error code	
W102	Latest warning code	

Setting procedure

Connect GX Works2 to the master station to configure the setting.

1. Create a project on GX Works2.

For "Series", select "QCPU (Q mode)" and for "Type", select "Q10UDH".

[Project] ⇒ [New...]

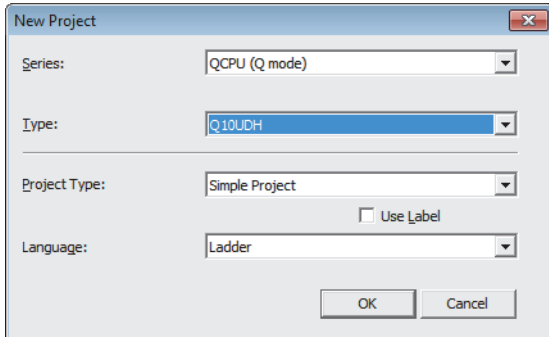

2. Display the network parameter setting window and configure the setting as follows.

Project window ⇒ [Parameter] ⇒ [Network Parameter] ⇒ [Ethernet/CC IE/MELSECNET]

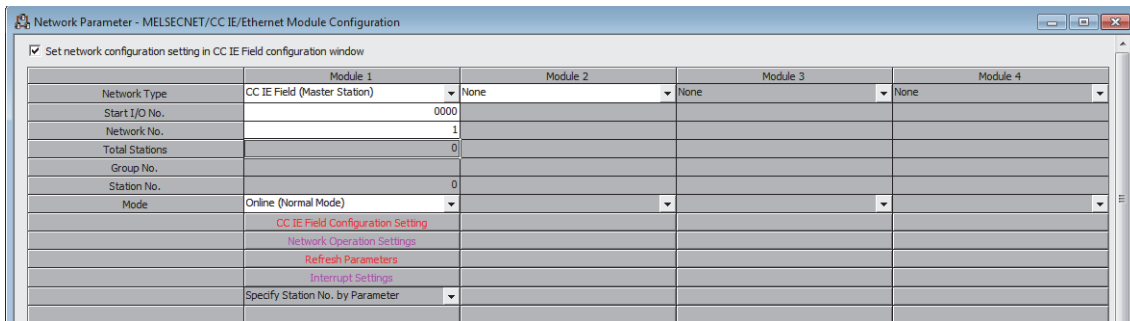

3. Display the "CC IE Field Configuration" window and configure the configuration and station number of the slave station as follows.

[CC IE Field Configuration Setting] button

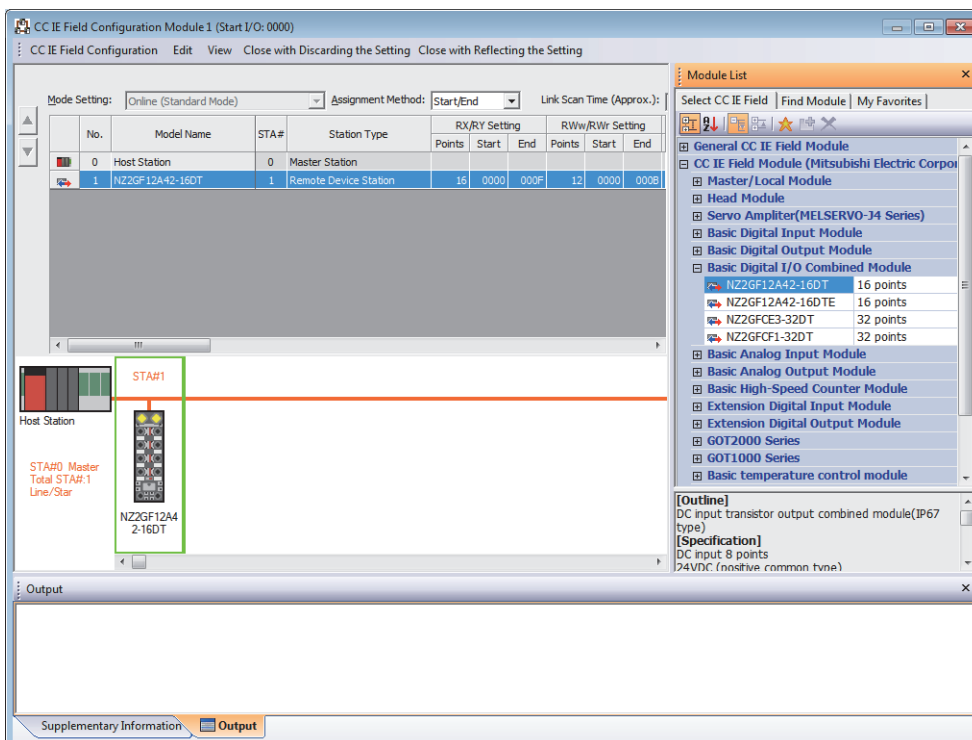

4. Close the "CC IE Field Configuration" window.

 [CC IE Field Configuration] ⇒ [Close with Reflecting the Setting]

5. Display the refresh parameter setting window and configure the setting as follows.

 [Refresh Parameters] button

Assignment Method

Points/Start

Start/End

	Link Side					PLC Side			
	Dev. Name	Points	Start	End		Dev. Name	Points	Start	End
Transfer SB	SB	512	0000	01FF	↔	SB	512	0000	01FF
Transfer SW	SW	512	0000	01FF	↔	SW	512	0000	01FF
Transfer 1	RX	16	0000	000F	↔	X	16	1000	100F
Transfer 2	RY	16	0000	000F	↔	Y	16	1000	100F
Transfer 3	RWr	12	0000	000B	↔	W	12	000100	00010B
Transfer 4	RWw	12	0000	000B	↔	W	12	000200	00020B
Transfer 5					↔				
Transfer 6					↔				
Transfer 7					↔				
Transfer 8					↔				

6. Write the set parameter to the CPU module of the master station and reset the CPU module, or turn off and on the power supply.

 [Online] ⇒ [Write to PLC...]

7. Display the "Parameter Processing of Slave Station" window.

 Project window ⇒ [Parameter] ⇒ [Network Parameter] ⇒ [Ethernet/CC IE/MELSECNET] ⇒ [CC IE Field Configuration Setting] button ⇒ Select an I/O module in "List of stations" ⇒ [CC IE Field Configuration] ⇒ [Online] ⇒ [Parameter Processing of Slave Station]

8. Set "Method selection" to "Parameter write".

Parameter Processing of Slave Station

Target Module Information: NZ2GF12A42-16DT
Start I/O No.:0000 - Station No.:1

Method selection:

Parameter Information

9. Set "Write Value". The following are the procedure.

- Click the title cell of "Initial Value" to select all the items and copy them.
- Click the title cell of "Write Value" to select all the items and paste the copy.
- Select the items to be changed, and set new values according to Initial setting description (☞ Page 106 Initial setting description).

Parameter Processing of Slave Station

Target Module Information: NZ2GF12A42-16DT
Start I/O No.:0000 - Station No.:1

Method selection: Parameter write
The parameters are written to the target module.

Parameter Information
Checked parameters are the targets of selected processes.

Select All Cancel All Selections

Name	Initial Value	Unit	Read Value	Unit	Write Value	Unit	Setting Range	Description
Station parameter								
<input checked="" type="checkbox"/> Input response time setting	5: 10ms				5: 10ms			The input module
<input checked="" type="checkbox"/> Output HOLD/CLEAR setting	0: CLEAR				0: CLEAR			Set whether to f
<input checked="" type="checkbox"/> Cyclic data update watch tim...	0	x100ms		x100ms	0	x100ms	0 to 20	Set the cyclic d
<input checked="" type="checkbox"/> Initial operation setting	1: without ini...				1: without ini...			Set whether the
Basic module parameter								
<input checked="" type="checkbox"/> Number of ON times integrati...								Set the number
<input type="checkbox"/> Number of ON times integr...	0: Disable				0: Disable			The total numbe
<input type="checkbox"/> Number of ON times integr...	0: Disable				0: Disable			The total numbe
<input type="checkbox"/> Number of ON times integr...	0: Disable				0: Disable			The total numbe
<input type="checkbox"/> Number of ON times integr...	0: Disable				0: Disable			The total numbe

Clear All "Read Value" Clear All "Write Value"

Process Option
There is no option in the selected process.

-The refreshed device values of remote I/O or remote registers may be overwritten.
-Accesses the PLC CPU by using the current connection destination. Please check if there is any problem with the connection destination.
-Process is executed according to the parameters written in the PLC CPU.
-For information on items not displayed on the screen, please refer to the Operating Manual.

Execute

Import... Export... Close

10. Click the [Execute] button to write the parameter to the I/O module.

Program example

1. Create the following program with GX Works2.

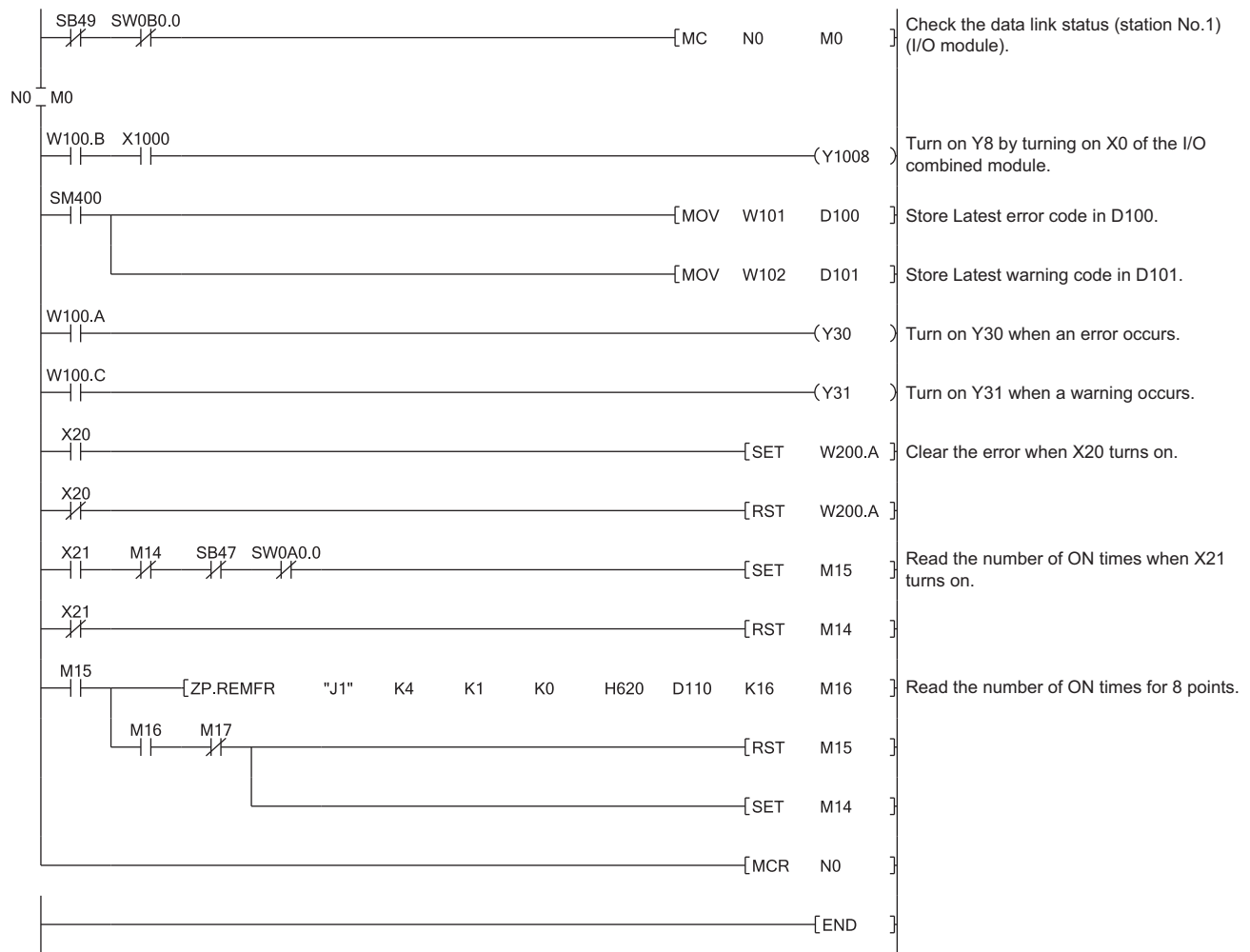

Point

If the master station does not receive a response for several link scans from the I/O module, the I/O module is determined as a cyclic transmission faulty station and the corresponding bit of the data link status (each station) (SW00B0 to SW00B7) turns on.

- Write the program to the CPU module of the master station, and reset the CPU module, or turn off and on the power supply.
- Put the CPU module of the master station into RUN.

9.4 Program Example for the Number of ON Times Integration Function

This section describes the program examples for checking and clearing the number of ON times when the number of ON times integration function is used.

Program example for checking the number of ON times

For the program for checking the number of ON times, refer to the following.

☞ Page 104 Program Example

Program example for clearing the number of ON times

System configuration

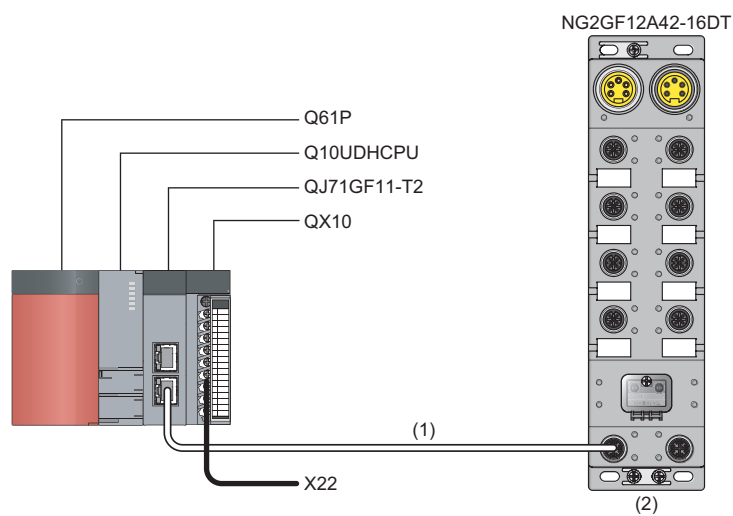

(1) Network No.1

(2) Station No.1

■Assignment of link devices

The assignment of link devices is the same as that in the following section.

☞ Page 105 Assignment of link devices

Programming condition

This program clears Number of ON times integration value Y8 of the I/O combined module when X22 turns on.

Initial setting description

The following table lists the initial settings of the I/O combined module.

Item	Description
Input response time setting	1.0ms
Output HOLD/CLEAR setting	CLEAR
Cyclic data update watch time setting	200ms
Initial operation setting	Without initial processing
Input OFF delay setting X0 to X7	0
Number of ON times integration function enable Y8 to YF	Enable
Fast logic setting Y8 to YB	Disable

Devices used by user

Device	Description
X22	Number of ON times clear switch QX10 (X20 to X2F)
D145	Number of ON times clear target device specification
D146	Number of ON times integration value clear completed confirmation
D147	Number of ON times clear target device specification clear
M30 to M41	Contact for clearing the number of ON times
SB47	Own station baton pass status (master station)
SW0A0.0	Baton pass status (station No.1)

Setting procedure

Set the same contents from procedures 1 to 6 in the following section.

 Page 107 Setting procedure

Program example

1. Create the following program with GX Works2.

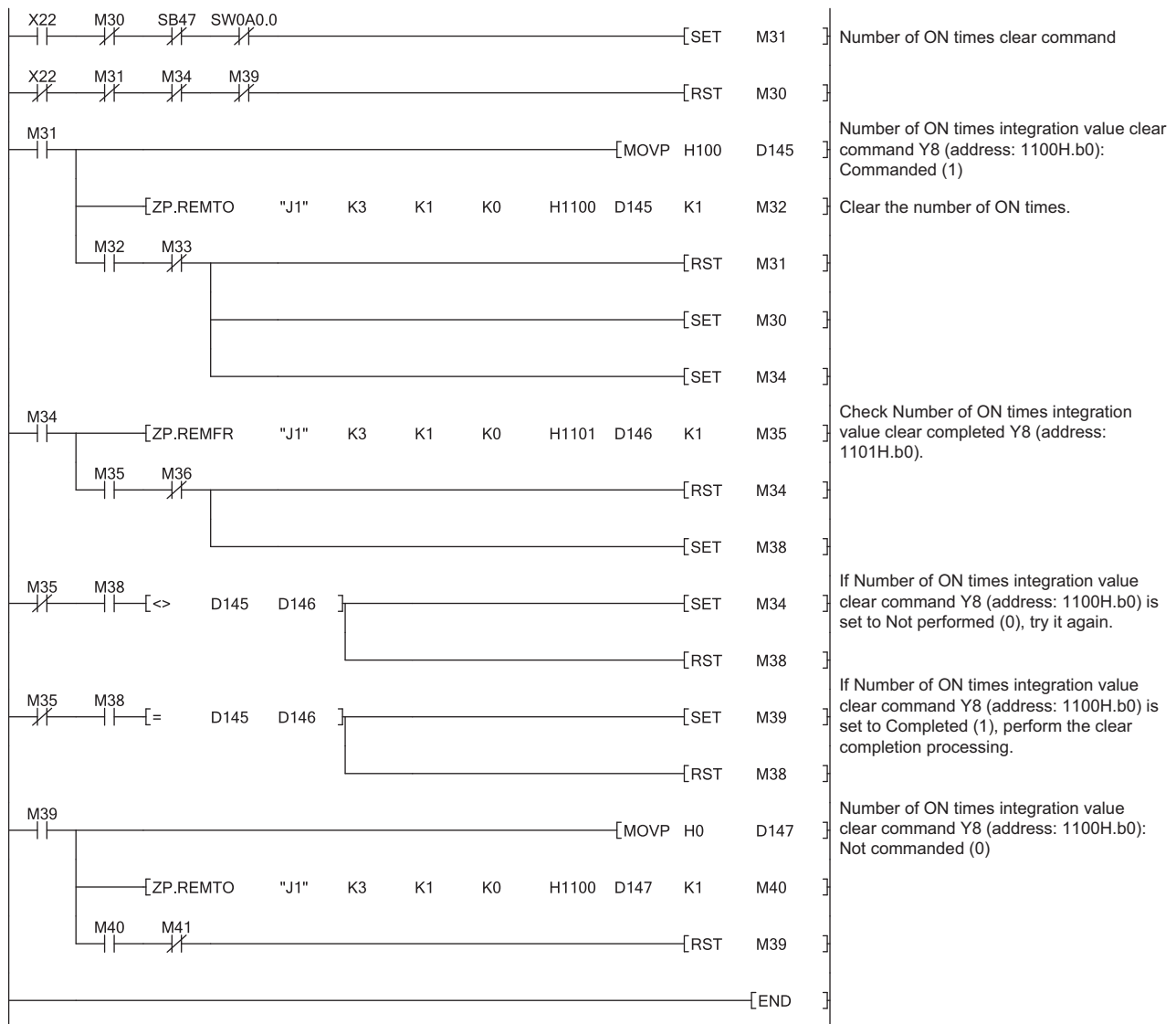

- Write the program to the CPU module of the master station, and reset the CPU module, or turn off and on the power supply.
- Put the CPU module of the master station into RUN.
- Turning on X22 clears Number of ON times Y8 of the I/O combined module.

9.5 Program Example for the Fast Logic Function

This section describes the program examples for when the fast logic function is used.

Turning off the module power supply changes the value in Fast logic setting Y□ (address: 0120H to 0127H) to the default value (Disable (0)). (The parameter is not stored in the nonvolatile memory.)

Thus, when the fast logic function is set with a program, not by the parameter setting of an engineering tool, the parameter can be set again easily.

Program example for the fast logic function

System configuration

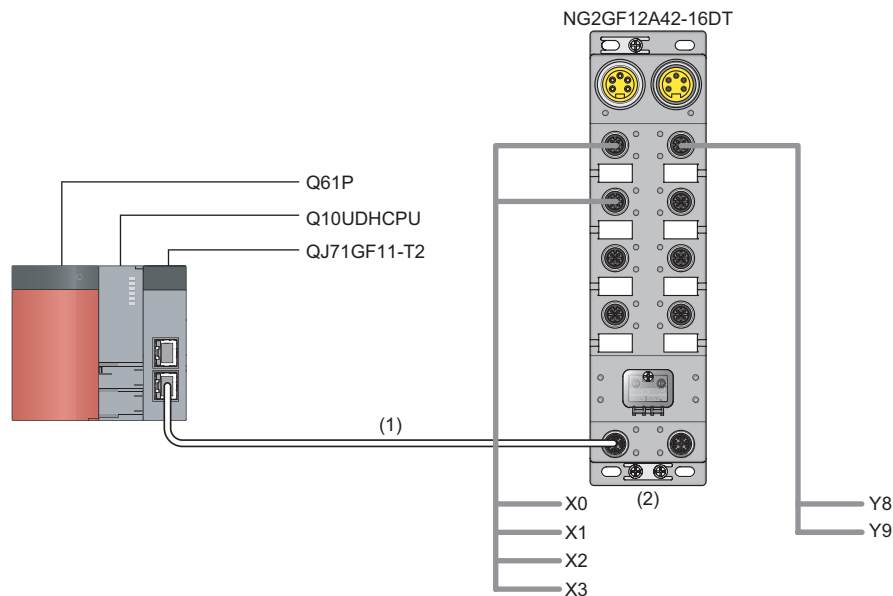

(1) Network No.1

(2) Station No.1

■Assignment of link devices

The assignment of link devices is the same as that in the following section.

☞ Page 105 Assignment of link devices

Programming condition

When both X0 and X1 of the I/O combined module turn on, Y8 is turned on. When both X2 and X3 of the I/O combined module turn on, Y9 is turned on.

Initial setting description

The following table lists the initial settings of the I/O combined module.

Item	Description
Input response time setting	1.0ms
Output HOLD/CLEAR setting	CLEAR
Cyclic data update watch time setting	200ms
Initial operation setting	With initial processing
Input OFF delay setting X0 to X7	0
Number of ON times integration function enable Y8 to YF	Enable
Fast logic setting Y8 to YB	Y8 to Y9: Enable
	YA to YB: Disable

Devices used by user

Device	Description
D0 to D6	Temporary data for parameter setting
M1 to M7, M20 to M21	Contact for parameter setting
SB47	Own station baton pass status (master station)
SW0A0.0	Baton pass status (station No.1)
W100.8	Initial processing request flag (RWr0.b8)
W100.9	Operation condition setting completion flag (RWr0.b9)
W200.8	Initial processing completion flag (RWw0.b8)
W200.9	Operation condition setting request flag (RWw0.b9)

Setting procedure

Set the same contents from procedures 1 to 6 in the following section.

 Page 107 Setting procedure

Program example

1. Create the following program with GX Works2.

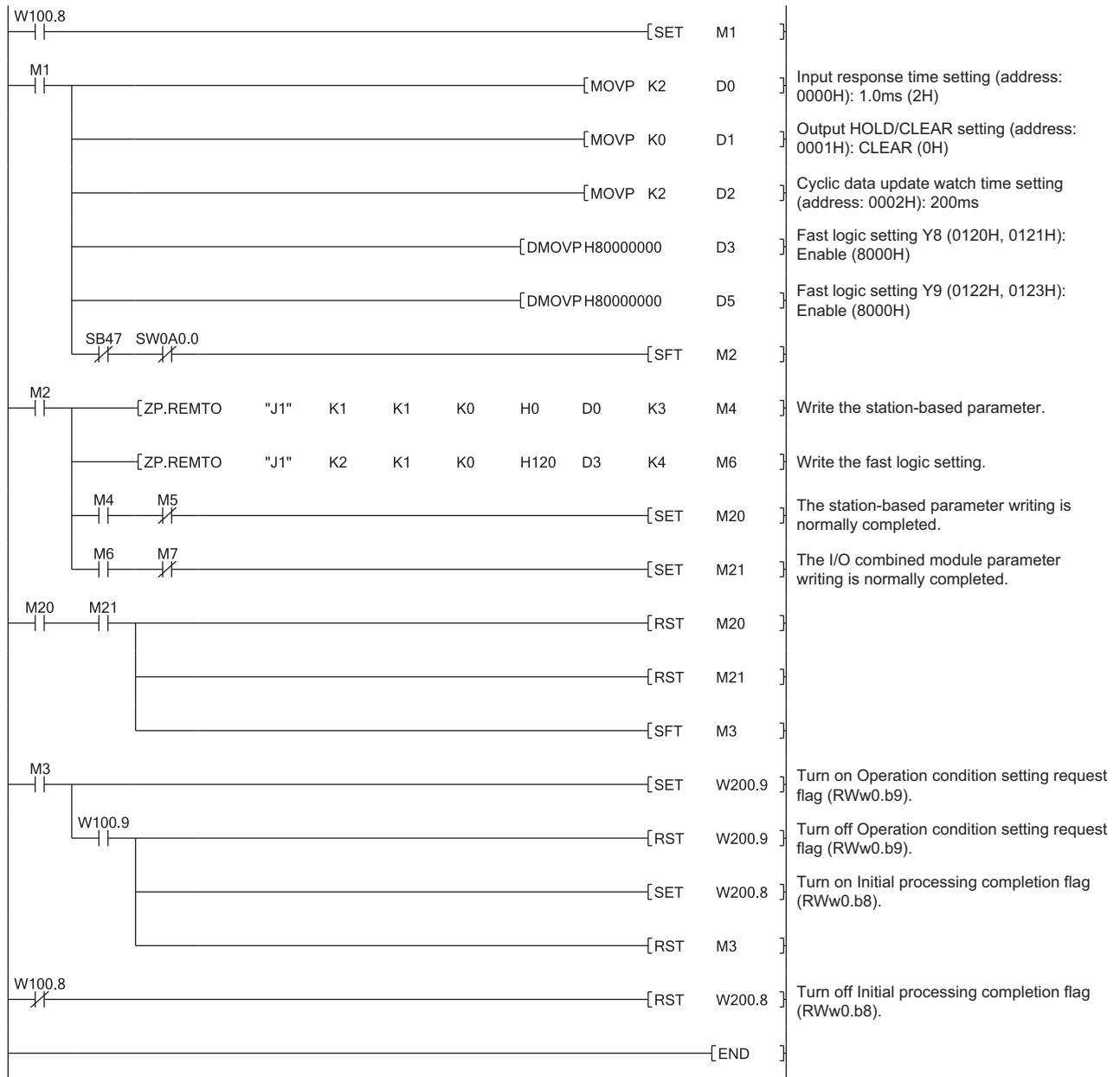

2. Write the program to the CPU module of the master station, and reset the CPU module, or turn off and on the power supply.

3. Put the CPU module of the master station into RUN.

Program example for checking the fast logic enable or disable status

This section describes the program for reading the fast logic enable status.

When the parameter setting of the fast logic function is completed and Remote READY (RWr0.b11) is on, the fast logic enable status can be read.

System configuration

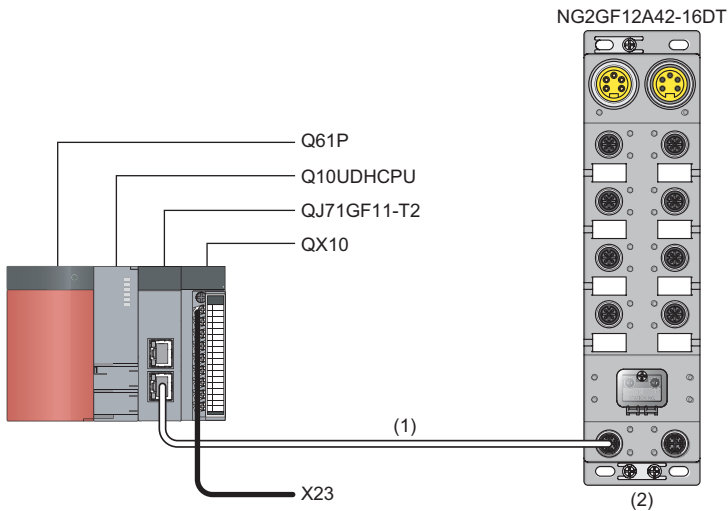

- (1) Network No.1
(2) Station No.1

■Assignment of link devices

The assignment of link devices is the same as that in the following section.

☞ Page 105 Assignment of link devices

Programming condition

This program reads the enable status of Fast logic setting Y8 to YB of the I/O combined module.

Initial setting description

The initial setting contents are the same as those in the following section.

☞ Page 115 Initial setting description

Devices used by user

Device	Description
X23	Fast logic enable status read switch
D105	Fast logic enable status acquisition
M25 to M28	Contact for reading the fast logic enable status
SB47	Own station baton pass status (master station)
SW0A0.0	Baton pass status (station No.1)
W100.B	Remote READY (RWr0.b11)

Setting procedure

Set the same contents from procedures 1 to 6 in the following section.

☞ Page 107 Setting procedure

Program example

1. Create the following program with GX Works2.

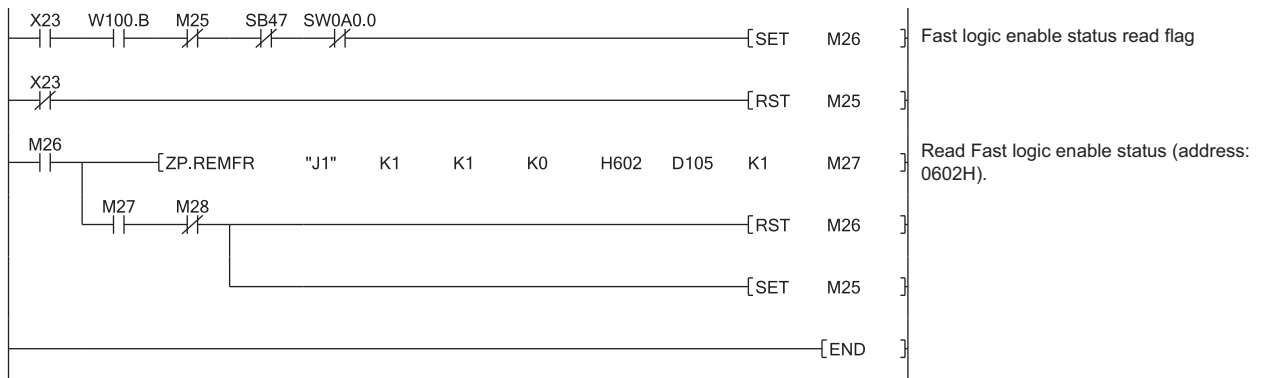

2. Write the program to the CPU module of the master station, and reset the CPU module, or turn off and on the power supply.
3. Put the CPU module of the master station into RUN.

10 MAINTENANCE AND INSPECTION

The I/O module has no special item to be inspected. However, to maintain the best condition of the system, perform the inspection in accordance with the items described in the user's manual of the CPU module used.

MEMO

11 TROUBLESHOOTING

This chapter describes error contents that may occur while the I/O module is used and those troubleshooting. Details are described using GX Works2.

11.1 Checking for the Error Codes and the Warning Codes

11

Error codes can be checked by any of the following methods:

- Page 121 Checking by executing a command of the slave station
- Page 123 Checking by Error code (RWr1)

Warning codes can be checked by any of the following methods:

- Page 121 Checking by executing a command of the slave station
- Page 123 Checking by Warning code (RWr2)

Checking by executing a command of the slave station

This section describes how to check the errors by executing a command of the slave station.

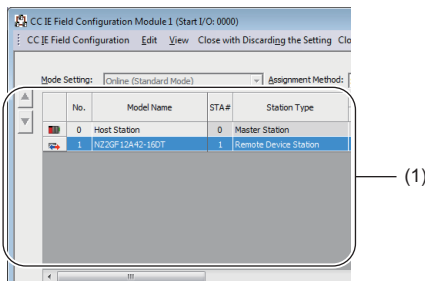

(1) List of stations

1. Select the I/O module in "List of stations" on the "CC IE Field Configuration" window.

2. Open the "Command Execution of Slave Station" window.

[CC IE Field Configuration] ⇒ [Online] ⇒ [Command Execution of Slave Station]

3. Set "Method selection" to "Error history read" and click the [Execute] button.

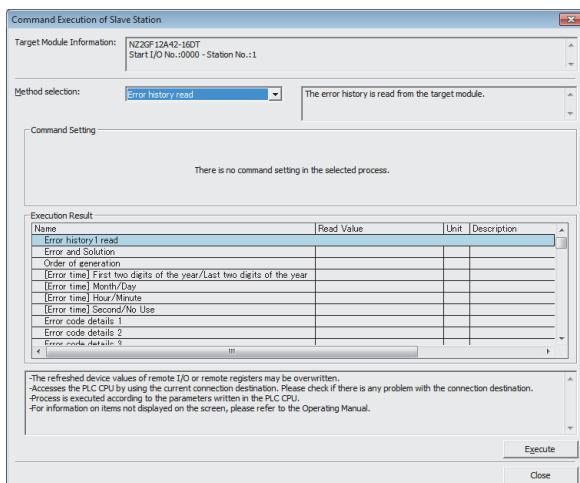

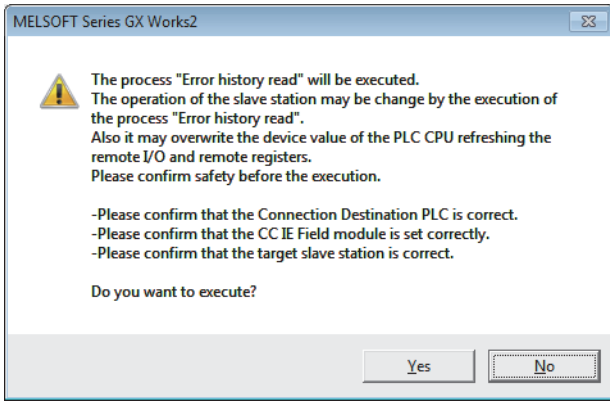

4. In the window that appears (shown left), click the [Yes] button.

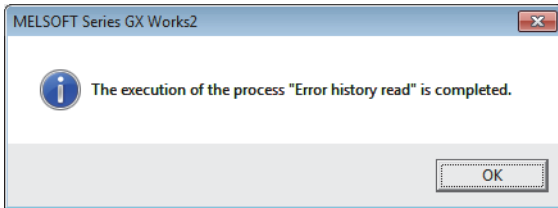

5. In the window that appears (shown left), click the [OK] button.

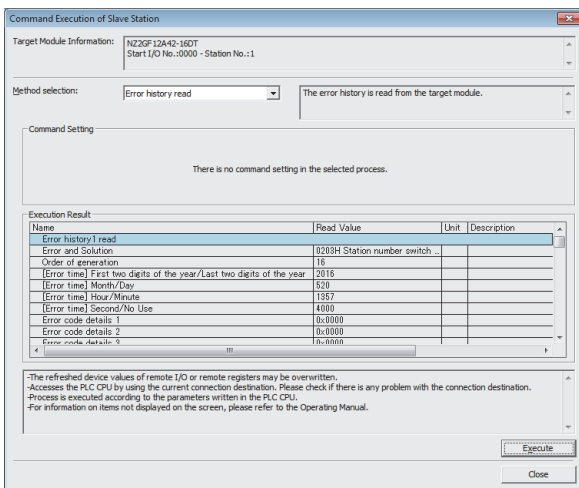

6. The error history of the I/O module is displayed in "Execution Result".

Item	Contents
Error and Solution	The action for the error is displayed.
Order of generation	The order of error occurrence is displayed. (The value of 0 to 65535 is stored.)
[Error time] First two digits of the year/Last two digits of the year	The date and hour of error occurrence is displayed. (When the tens place of Month, Hour, or Second is "0", "0" is omitted.)
[Error time] Month/Day	
[Error time] Hour/Minute	
[Error time] Second/No Use	
Error code details 1 ⋮ Error code details 10	The value of Error code details □ of the remote buffer memory when an error occurs is stored.

- The error history registers 15 errors at a maximum. If 16 or more errors occur, errors are deleted from the oldest.
- If the same error occurs continuously, only the error that occurred first is stored to the error history.
- Even after the power of the module is turned off and on, the error history remains.
- To initialize the error history, set "Method selection" to "Error history clear request" on the "Command Execution of Slave Station" window and click the [Execute] button.

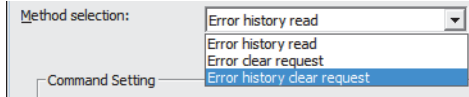

Checking by Error code (RWr1)

Check the latest error code with the remote register of the master/local module.

[Online] ⇒ [Monitor] ⇒ [Device/Buffer Memory Batch]

Ex.

When the refresh target device for Error code (RWr1) is W101

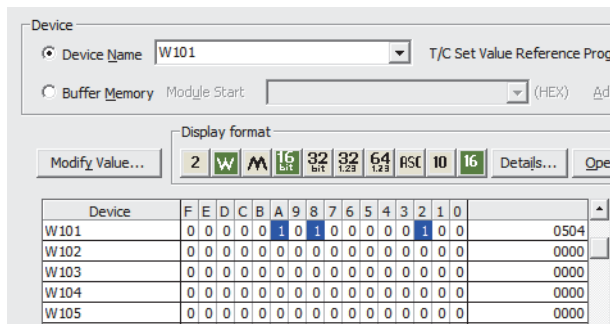

Checking by Warning code (RWr2)

Check the latest warning code with the remote register of the master/local module.

[Online] ⇒ [Monitor] ⇒ [Device/Buffer Memory Batch]

Ex.

When the refresh target device for Warning code (RWr2) is W102

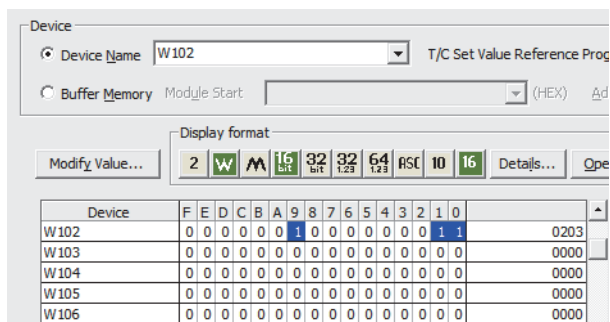

11.2 Error Code List

This section describes error codes.

Error codes are classified by error number as follows.

Error code	Classification	Reference
0000H to 3FFFH D529H, D52BH	I/O module error	Page 124 Error code list (0000H to 3FFFH, D529H, D52BH)
D000H to DFFFH (D529H and D52BH excluded)	CC-Link IE Field Network error	Page 127 Error code list (D000H to DFFFH (D529H and D52BH excluded))

Error code list (0000H to 3FFFH, D529H, D52BH)

The errors are classified into the following three types.

Classification	Description
Major error	An error that cannot be recovered. The RUN LED turns off.
Moderate error	An error where the module cannot continue to operate. The ERR. LED turns on.
Minor error	An error where the module can continue to operate. The ERR. LED flashes.

If an error occurs, check that the D LINK LED is on. Then take corrective actions as listed below.

Error code (hexadecimal)	Classification	Error name	Description and cause	Action
0001H	Major error	WDT error	The WDT (watchdog timer) has timed out.	<ul style="list-style-type: none"> Take measures against noise with a shielded cable for connection. Then turn off and on the module. If this error persists, the module may be in failure. Please consult your local Mitsubishi representative.
0002H	Major error	ROM error	An error has been detected in the ROM diagnostics upon start up.	
0003H	Major error	RAM error	An error has been detected in the RAM diagnostics upon start up.	
0004H	Major error	Non-volatile memory error	The data in the non-volatile memory are faulty.	
0005H	Major error	Non-volatile memory error (module information)	The module information stored in the non-volatile memory are faulty.	
0006H	Major error	I/O circuit error	An error has been detected when the access to the I/O circuit was checked upon start up.	
0007H	Major error	Non-volatile memory access failure	The access to the non-volatile memory has failed.	
000BH	Major error	Communication error 3	Invalid data where the communication LSI setting changes have been received.	
000CH	Major error	Communication error 4	Invalid data where the communication LSI setting changes have been received.	
000DH	Major error	Communication error 5	The communication LSI is faulty.	
0010H	Major error	Hardware failure	Module hardware error	Turn off and on the module. If this error persists, the module may be in failure. Please consult your local Mitsubishi representative.

Error code (hexadecimal)	Classification	Error name	Description and cause	Action
0101H	Moderate error	Non-volatile memory error (module working information)	The module working information stored in the non-volatile memory are faulty.	<ul style="list-style-type: none"> Set Not commanded (0), Commanded (1), and Not commanded (0) in Module operation information initialization command (address: 1004H) and set the parameters of the non-volatile memory to default. Note that number of ON times integration value will be initialized to zero. Take measures against noise with a shielded cable for connection. If this error persists, the module may be in failure. Please consult your local Mitsubishi representative.
0102H	Moderate error	Non-volatile memory error (parameter)	The parameter data stored in the non-volatile memory are faulty.	<ul style="list-style-type: none"> Set Not commanded (0), Commanded (1), and Not commanded (0) in Parameter area initialization command (address: 1002H) and set the parameters of the non-volatile memory to default. Correct the parameter settings. Take measures against noise with a shielded cable for connection. If this error persists, the module may be in failure. Please consult your local Mitsubishi representative.
0103H ¹	Moderate error	Power supply voltage error	Power supply monitor state flag (RW3.b0) is on and the module-and-sensor power supply or the load power supply has a voltage error.	<ul style="list-style-type: none"> Check the setting of Power supply monitor request flag (RW3.b0), and wiring of the power supplies, and the status of each power supply. If an error occurs at the startup of the system or when the system has stopped, correct the timing to turn on or off Power supply monitor request flag (RW3.b0).
0104H	Moderate error	Date out of range error	The clock data acquired from the CPU module is incorrect.	There may be an influence from noise or a hardware error. If the same error occurs again even after measures have been taken against noise, please consult your local Mitsubishi representative.
0201H	Minor error	Non-volatile memory data error (error history)	The error history data stored in the non-volatile memory are faulty.	<ul style="list-style-type: none"> The module will be automatically recovered immediately after the error occurs. Note that the error history of the errors that have occurred will be lost. Take measures against noise with a shielded cable for connection. If this error persists, the module may be in failure. Please consult your local Mitsubishi representative.
0202H ²	Minor error	Remote buffer memory access error	Areas other than those of the remote buffer memory have been accessed with the REMFR/REMTO instructions.	Correct the setting data of the REMFR/REMTO instruction to access the remote buffer memory.
0203H	Minor error	Station number switch changed error	The station number setting switches have been changed with the module power on.	Set the switch again to the station number that has been set before.
0503H ³	Moderate error	Parameter data error (input OFF delay)	The received parameter data values are incorrect or outside the range.	<p>■ Input module Check that the value set in Input OFF delay setting X□ (address: 0110H to 012FH) is within the setting range (0 to 150000).</p> <p>■ I/O combined module Check that the value set in Input OFF delay setting X□ (address: 0110H to 011FH) is within the setting range (0 to 150000).</p>
0504H ³	Moderate error	Parameter data error (cyclic data update watch time setting)	The received parameter data values are incorrect or outside the range.	<p>Correct the parameter settings.</p> <ul style="list-style-type: none"> Check that the set value in Cyclic data update watch time setting (address: 0002H) is within the setting range (0 to 20).
0506H ³	Moderate error	Parameter data error (initial operation setting)	The received parameter data values are incorrect or outside the range.	<p>Correct the parameter settings.</p> <ul style="list-style-type: none"> Check that the set value in Initial operation setting (address: 0004H) is within the setting range (With initial processing (0), Without initial processing (1)).

Error code (hexadecimal)	Classification	Error name	Description and cause	Action
D529H	Major error	Communication error 1	A hardware error has occurred in the communication LSI.	<ul style="list-style-type: none"> • A malfunction may have occurred due to noise or others. Check the cable distance or grounding condition of each device. Then take measures against noise. • If the same error occurs again, the hardware of the module may be in failure. Please consult your local Mitsubishi representative.
D52BH	Major error	Communication error 2	A hardware error has occurred in the communication LSI.	

*1 Information of the module that has detected an error is stored in Error code details 1 of Error history data □ (address: 0A00H to 0AEFH). For details, refer to the following.

☞ Page 160 Error history data of when a power supply voltage error occurs

*2 The start address of the remote buffer memory areas specified with the REMFR/REMTO instruction is stored in Error code details 1 of Error history data □ (address: 0A00H to 0AEFH).

*3 The remote buffer memory address of the parameter that has detected an error is stored in Error code details 1 of Error history data □ (address: 0A00H to 0AEFH).

The set value upon an error is stored in Error code details 2. The setting values of the lower 16 bits and higher 16 bits are respectively stored in Error code details 2 and Error code details 3 of Input OFF delay setting and Fast logic setting that have a setting value of 32 bits.

Point

When multiple errors occur, only the latest error code is stored in Error code (RWr1).

The errors that have occurred in the past can be checked in the error history of the engineering tool.

For error history, refer to the following.

☞ Page 121 Checking by executing a command of the slave station

☞ Page 159 Error history data

Error code list (D000H to DFFFH (D529H and D52BH excluded))



When an error occurs, the ERR. LED does not turn on. The D LINK LED flashes or turns off.

Troubleshoot the problem with the CC-Link IE Field Network diagnostics.

Error code (hexadecimal)	Classification	Error name	Description and cause	Action
D0E0H	Communication error	Station type mismatch	The network parameter is incorrect or outside the range.	In the network configuration settings of the master station (submaster station), change the station type to that of the module.
D0E1H	Communication error	Own station reserved	The network parameter is incorrect or outside the range.	<ul style="list-style-type: none"> In the network configuration settings of the master station (submaster station), cancel the reserved station setting. Change the station number of the module to a station number that is not reserved.
D0E2H	Communication error	Station No. already in use (own station)	The station number switch setting is incorrect.	<ul style="list-style-type: none"> Set a unique station number. After taking the above action, turn off and on or reset all the stations where this error has been detected.
D0E3H	Communication error	Own station No. out of range	The network parameter is incorrect or outside the range.	Add the station information of the module in the network configuration settings of the master station (submaster station).
D217H	Communication error	Transient data command error	The transient data request command is incorrect.	Correct the request command at the request source, and retry the operation.
D2A0H	Communication error	Receive buffer full	The target station is overloaded and cannot receive transient data.	<ul style="list-style-type: none"> Check the network status using CC-Link IE Field Network diagnostics of the engineering tool to take the appropriate action. When the target station is overloaded and cannot receive transient data, send the data to the target station after a while.
D2A3H	Communication error	Transient data length error	The received transient data is incorrect.	Correct the number of data (frame length) at the request source, and retry the operation.
D72AH	Communication error	Station number switch out of range	A station number out of range (a value other than 1 to 120) has been set.	Set the station number within the allowable range.
DF01H	Communication error	Transient data divided error	The divided transient data have been received.	Send the transient data that is not divided.

Point 

When multiple errors occur, only the latest error code is stored in Error code (RWr1).
 The errors that have occurred in the past can be checked in the error history of the engineering tool.
 For error history, refer to the following.

-  Page 121 Checking by executing a command of the slave station
-  Page 159 Error history data

11.3 Checking the LEDs

This section describes how to troubleshoot the system by the LEDs.

When the PW LED is on in red

Check item	Action
Is the voltage of the module-and-sensor power supply (24VDC) within the specified range?	Set the voltage value within the range of performance specifications.
Is the operating ambient temperature within the specified range?	Set the operating ambient temperature within the range of performance specifications.
Is the derating within the specified range?	Set the derating within the range of performance specifications.

When the PW LED does not turn on

Check item	Action
Is any LED other than the PW LED turned on?	When any LED other than the PW LED turns on, the possible cause is a hardware failure. Please consult your local Mitsubishi representative.
Is the module-and-sensor power supply (24VDC) wired?	Wire the module-and-sensor power supply (24VDC).
Is the module-and-sensor power supply (24VDC) on?	Turn on the module-and-sensor power supply (24VDC).
Is the voltage of the module-and-sensor power supply (24VDC) within the specified range?	Set the voltage value within the range of performance specifications.

When the L PW LED is on in red

Check item	Action
Is the voltage of the load power supply (24VDC) within the specified range?	Set the voltage value within the range of performance specifications.
Is the operating ambient temperature within the specified range?	Set the operating ambient temperature within the range of performance specifications.
Is the derating within the specified range?	Set the derating within the range of performance specifications.

When the L PW LED does not turn on

Check item	Action
Is the load power supply (24VDC) wired?	Wire the load power supply (24VDC).
Is the load power supply (24VDC) on?	Turn on the load power supply (24VDC).
Is the voltage of the load power supply (24VDC) within the specified range?	Set the voltage value within the range of performance specifications.

When the I/O LED is on in red

Check item	Action
Is the voltage of the load power supply (24VDC) within the specified range?	Set the voltage value within the range of performance specifications.
Is the supply current to the sensor power supply or the output current whose I/O LED is on in red within the specified range?	Set the current value within the range of performance specifications.
Is the operating ambient temperature within the specified range?	Set the operating ambient temperature within the range of performance specifications.
Is the derating within the specified range?	Set the derating within the range of performance specifications.
Is any input or output where the LED is on in red short-circuited?	Check the wiring of the input or output and remove the short-circuit.

When the RUN LED does not turn on

Check item	Action
Does the voltage of the module power supplied externally reach to the voltage of the specifications?	Check that module power supply voltage is within the range of performance specifications. (☞ Page 20 I/O Module Specifications) After the check, power off and on the module. If the RUN LED does not turn on even after the module power supply is turned off and on, the possible cause is a module failure. Please consult your local Mitsubishi representative.
Does any hardware error occur?	

When the MODE LED flashes

Check item	Action
Is the I/O module in execution of the unit test?	When the I/O module is in execution of the unit test, the MODE LED turns off after the unit test is completed. Take corrective action according to the result of the unit test. (☞ Page 131 Unit Test)

When the ERR. LED flashes or turns on

Check item	Action
Has any error occurred?	Identify the error factor of the I/O module with the engineering tool to take the corrective action. (☞ Page 121 Checking for the Error Codes and the Warning Codes)

When the D LINK LED turns off

Check item	Action
Does the own station in network operate normally?	Connect the engineering tool to the master station, and then check that a data link is established in the own station by using CC IE Field diagnostics. (☞ User's manual for the master/local module used)
Are 1000BASE-T-compliant Ethernet cables used?	Replace the cable with a 1000BASE-T-compliant Ethernet cable. (☞ User's manual for the master/local module used)
Is the station-to-station distance 100m or less?	Change the station-to-station distance to 100m or less.
Does the cabling condition (bending radius) meet the specifications?	Refer to the manual for the Ethernet cable used, and correct the bending radius.
Is any Ethernet cable disconnected?	Replace the Ethernet cable.
Do other stations connected to the I/O module normally operate?	Check that the power supplies of the other stations are turned on.
Does the switching hub normally operate?	<ul style="list-style-type: none"> • Check that a 1000BASE-T-compliant switching hub is used. (☞ User's manual for the master/local module used) • Check that the power supply of the switching hub is turned on.
Is the station number of the I/O module duplicated with any of other stations?	Two or more stations are duplicated. Change the setting so that all the station numbers are different.

When the D LINK LED flashes

Check item	Action
Does the station number setting of the I/O module match the station number of the I/O module set in the network configuration settings of the master station or in the CC IE Field Configuration?	Match the station number of the I/O module with the station number set in the network configuration settings of the master station or in the CC IE Field Configuration.
Is the station type remote device station?	Change the station type to the remote device station in the network configuration settings of the master station.
Is the I/O module a reserved station?	Change the setting of reserved/error invalid station to other than the reserved station in the network configuration settings of the master station.
Is the station number setting switch set to other than 1 to 120?	Change the setting within the range from 1 to 120.
Is stop of the data link checked through CC-Link IE Field Network diagnostics?	Check the link status through CC-Link IE Field Network diagnostics and start the link when the data link is stopped.
Has the connection been changed to the other master station with a different network number?	<ul style="list-style-type: none"> • Correct the connection to the previous master station. • To communicate with the master station with a different network number, power off and on the I/O module.

When the L ER LED turns on

Check item	Action
Are Ethernet cables normal?	<ul style="list-style-type: none"> • Check that 1000BASE-T-compliant Ethernet cables are used. (📖 User's manual for the master/local module used) • Check that the station-to-station distance is 100m or less. • Check that the Ethernet cables are not disconnected.
Does the switching hub in the system normally operate?	<ul style="list-style-type: none"> • Check that a 1000BASE-T-compliant switching hub is used. (📖 User's manual for the master/local module used) • Check that the power supply of the switching hub is turned on.
Do other stations connected to the I/O module normally operate?	Check that the power supplies of the other stations are turned on.
Is the mode of the module on the master station set to other than Online?	Change the mode of the module to Online.
Is there any noise affecting the system?	<ul style="list-style-type: none"> • Check the status of wiring. • Ground the control panel or the steel shelf where an I/O module is installed.*1
Is the loopback function enabled for the master station?	When the loopback function is enabled, check that the ring topology is correctly configured for the PORT where the L ER LED is on. (📖 User's manual for the master/local module used)

*1 When the I/O module is installed in the control panel or steel shelf, the FG metal fitting of the I/O module can be connected electrically with them. Thus, if the control panel or steel shelf is not properly grounded, the noise may enter the FG through the control panel or steel shelf.

When the LINK LED turns off

Check item	Action
Are Ethernet cables normal?	<ul style="list-style-type: none"> • Check that 1000BASE-T-compliant Ethernet cables are used. (📖 User's manual for the master/local module used) • Check that the station-to-station distance is 100m or less. • Check that the Ethernet cables are not disconnected.
Do the switching hub and other stations in the system normally operate?	<ul style="list-style-type: none"> • Check that a 1000BASE-T-compliant switching hub is used. (📖 User's manual for the master/local module used) • Check that the power supplies of the switching hub and other stations are turned on.

Point

If link-up processing is repeated due to a condition of a device on the line, it may take a longer time for the LINK LED to turn on.

This phenomenon may be eliminated by changing the module PORT into which the Ethernet cable is connected (example: PORT1 → PORT2).

11.4 Unit Test

Run a unit test to check if there is any error in the I/O module.

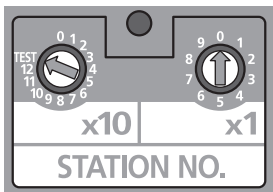
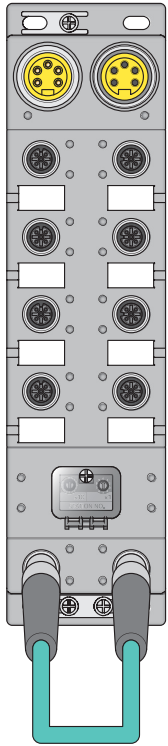

1. Power off the module.
2. Connect the PORT1 and PORT2 connectors of the I/O module with an Ethernet cable.

3. Set the station number setting switch as follows.
 - x10: TEST
 - x1: 0

For the setting procedure of the station number setting switch, refer to the following.

☞ Page 64 Setting procedure

4. Power on the module.
5. Unit test begins.

The MODE LED flashes while the unit test is being executed.

6. The MODE LED turns off when the unit test is completed.
 - If the test is completed normally, the ERR. LED does not turn on, but remains off.
 - If the test fails, the ERR. LED turns on. If the test fails, replace the Ethernet cable and run the test again. If the test fails again, it may be due to a hardware failure in the I/O module. Please consult your local Mitsubishi representative.

11.5 Troubleshooting for Each Phenomenon

This section describes troubleshooting for each phenomenon.

Perform troubleshooting for each phenomenon when the I/O module does not operate properly with no error. If an error occurs in the I/O module, identify the cause of the error using the engineering tool.

Check the following items in the order from the top.

When the ON/OFF status of an external input cannot be read

Check item	Action
Is the corresponding I/O LED of the input module or I/O combined module on when an external input device is on?	<p>If the LED does not turn on, there is a problem on the input wiring.</p> <p>Check the wiring confirming that the input wiring is not disconnected or short-circuited, or the voltage of the input signal is correct.</p> <p>For the rated input voltage, check the rated input voltage in the specifications of each input module or I/O combined module.</p> <ul style="list-style-type: none"> ☞ Page 20 Input module ☞ Page 34 I/O combined module <p>Refer to the following as well.</p> <ul style="list-style-type: none"> ☞ Page 134 Troubleshooting for input circuit
Is the setting of the refresh device correct?	<p>Check the refresh parameter and correct the setting of the refresh device so that it matches with the setting in the program. For the setting of the refresh parameters, refer to the following.</p> <ul style="list-style-type: none"> ☞ User's manual for the master/local module used
Is Remote READY (RWr0.b11) on?	<p>To enable reading the ON/OFF status of the external input when the module power supply is on, the initial processing must be executed by using Initial processing request flag (RWr0.b8) and Initial processing completion flag (RWw0.b8). Execute the initial processing to check that Remote READY (RWr0.b11) is on. For details, refer to the following.</p> <ul style="list-style-type: none"> ☞ Page 144 Initial processing request flag (RWr0.b8) ☞ Page 152 Initial processing completion flag (RWw0.b8)
Is the input OFF delay function used correctly?	<p>When the input OFF delay function is enabled, Remote input signal (RX) turns off after the delay time passes following OFF of an external device. Disable the input OFF delay function or change the setting of the delay time.</p> <p>For details on the setting related to the input OFF delay function, refer to the following.</p> <ul style="list-style-type: none"> ☞ Page 84 Input OFF Delay Function ☞ Page 156 Input OFF delay setting
Is any bit of Input X port status (RWr4) on?	<p>When any bit of Input X port status (RWr4) is on, a short circuit was detected in the input port for the bit. Check the wiring after checking that the input wiring is not disconnected or short-circuited and the voltage of the input signal is correct.</p>

When the ON/OFF status of an external output cannot be changed

Check item	Action
Is the L PW LED on?	Take corrective action according to the following. ☞ Page 128 When the L PW LED does not turn on
Does the corresponding I/O LED of the output module or I/O combined module turn on when an external output signal is turned on?	If the LED turns on, there is a problem on the output wiring. Check the wiring confirming that the output wiring is not disconnected or short-circuited. Refer to the following as well. ☞ Page 137 Troubleshooting for output circuit
Is the setting of the refresh device correct?	Check the refresh parameter and correct the setting of the refresh device so that it matches with the setting in the program. For the setting of the refresh parameters, refer to the following. ☞ User's manual for the master/local module used
Is Remote READY (RWr0.b11) on?	To enable changing the ON/OFF status of the external output when the module power supply is on, the initial processing must be executed by using Initial processing request flag (RWr0.b8) and Initial processing completion flag (RWw0.b8). Execute the initial processing to check that Remote READY (RWr0.b11) is on. For details, refer to the following. ☞ Page 144 Initial processing request flag (RWr0.b8) ☞ Page 152 Initial processing completion flag (RWw0.b8)
Is the fast logic function used correctly?	When the fast logic function is enabled, output Y is turned on or off not by the remote output signals (RY) received from the master module but by the internal operation result of the module. Disable the fast logic function or change the condition of output. For details on the fast logic function, refer to the following. ☞ Page 95 Fast Logic Function ☞ Page 157 Fast logic setting
Is any bit of Output Y channel status (RWr5) on?	When any bit of Output Y channel status (RWr5) is on, a short circuit was detected in the output signal for the bit. Check the wiring after checking that the output wiring is not disconnected or short-circuited.

Point

If an external input cannot be read or an external output cannot be controlled even after the above actions are taken, the I/O module may be failed. Please consult your local Mitsubishi representative.

When parameter read or write or CC-Link IE Field Network diagnostics fails

Check item	Action
Is the D LINK LED of the I/O module on?	Check the D LINK LED of the I/O module. If the D LINK LED does not turn on, refer to the following to perform troubleshooting. ☞ Page 129 When the D LINK LED turns off ☞ Page 129 When the D LINK LED flashes Refer to the following to check other LEDs. ☞ Page 128 Checking the LEDs
Is the version of the module on the master station correct?	Check the serial number (first five digits) of the module on the master station, and if the version is prior to the correct one, replace the module with a module of the applicable version. For the applicable version, refer to the following. ☞ Page 62 Applicable master station
Is the version of the engineering tool supported?	Please consult your local Mitsubishi representative.
Do the setting of the network parameter and that of the CPU module match?	Perform PLC verification on the network parameter to check those settings. When they are not matched, match the setting of the network parameter to that of the CPU module and write the module parameter of the slave station.
Is the voltage of the module power supply (24VDC) within the specified range?	Set the voltage value within the range of performance specifications.

11.6 Examples of Troubles with the I/O Module

Troubleshooting for input circuit

This section describes the troubleshooting for input circuit.

An input signal does not turn off No.1

■Cause

Drive by a switch with LED indicator

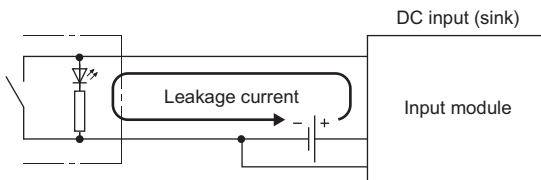

■Action

Connect an appropriate resistor as shown below so that a current through the input module may become lower than the OFF current.

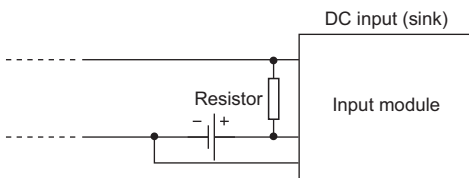

For the calculation example of a resistor to be connected, refer to the following.

☞ Page 135 Calculation example

■ Calculation example

When a module-and-sensor power supply (24VDC) of the input module is on and a switch with LED indicator that has a leakage current of 3mA at a maximum is connected

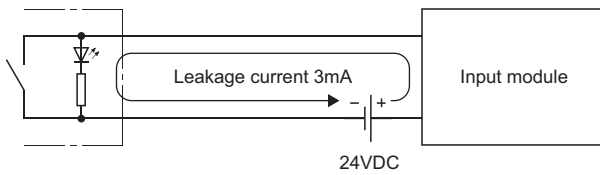

1. The OFF current through the input module is not 1.7mA or less. Therefore, connect a resistor as shown below.

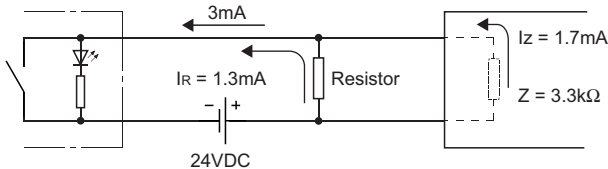

Z: Input impedance

2. To satisfy the condition, the current through the connected resistor should be 1.3mA or more. From the formula below, the value of the connected resistor is lower than 4.31kΩ.

$$I_R : I_z = Z : R$$

$$R \leq \frac{I_z}{I_R} \times Z = \frac{1.7}{1.3} \times 3.3 = 4.31[\text{k}\Omega]$$

3. When the resistor (R) is 3.9kΩ, for example, the power capacity (W) of the resistor (R) becomes 0.179W.

$$W = V^2 \div R = 26.4^2 \div 3900 = 0.179[\text{W}]$$

V: Input voltage

4. Because the resistor requires the power capacity of 3 to 5 times as large as the actual current consumption, the resistor connected to the terminal should be 3.9kΩ and 1 to 2W.
5. OFF voltage when the resistor (R) is connected becomes 5.36V. This satisfies that the OFF voltage of the input module is 8V or lower.

$$\frac{1}{\frac{1}{3.9[\text{k}\Omega]} + \frac{1}{3.3[\text{k}\Omega]}} \times 3[\text{mA}] = 5.36[\text{V}]$$

An input signal does not turn off No.2

■Cause

By using two power supplies, a sneak path is configured.

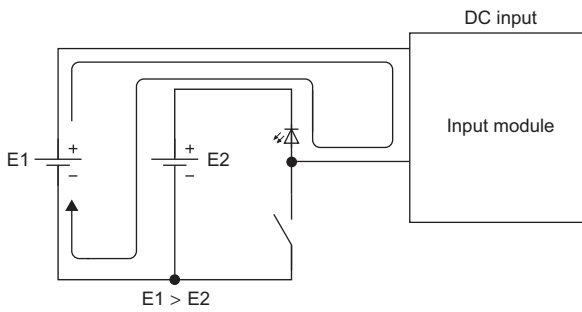

■Action

- Use one power supply.
- To prevent the sneak path, connect a diode as shown below.

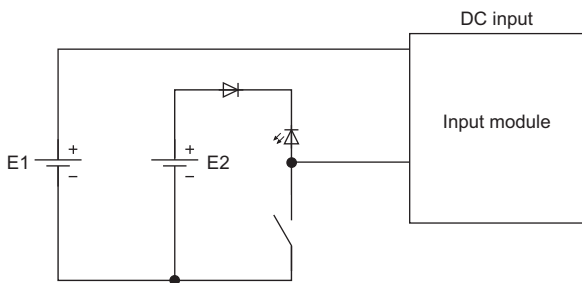

A signal incorrectly inputs data

■Cause

Noise is taken as input data.

■Action

- To prevent excessive noise, avoid installing power cables together with I/O cables.
- Connect surge absorbers to noise-generating devices such as relays and conductors using the same power supply or take other noise reduction measures.

Troubleshooting for output circuit

This section describes the troubleshooting for output circuit.

A load momentarily turns on when the load power supply is powered on

■Cause

An incorrect output occurs due to the stray capacitance (C) between collector and emitter of a photocoupler. (When a high sensitivity load (such as a solid state relay) is used, this incorrect output may occur.)

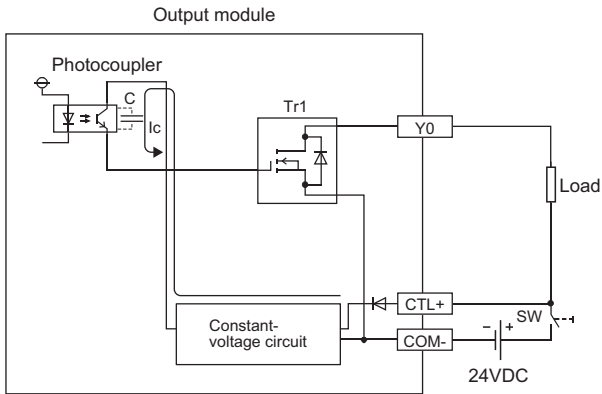

When the load power supply is powered on rapidly, the current (I_c) flows due to the stray capacitance (C). The current (I_c) flows to the gate of the transistor (Tr1) of the next stage and the output Y0 turns on for approximately 100 μ s.

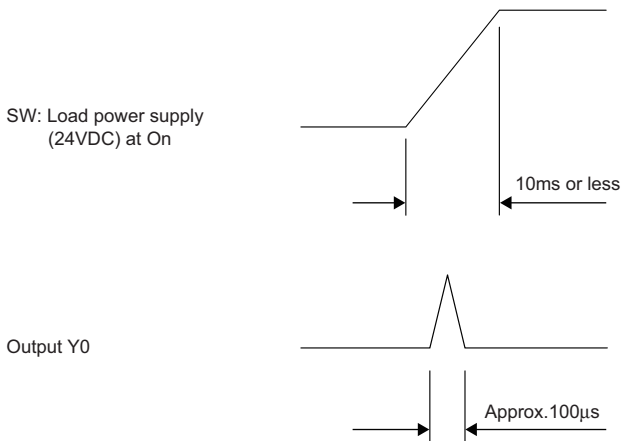

■Action

Before powering on or off the load power supply, check that the time taken to power on the load power supply itself is 10ms or more. Then, install a switch (SW1) to the primary side of the load power supply.

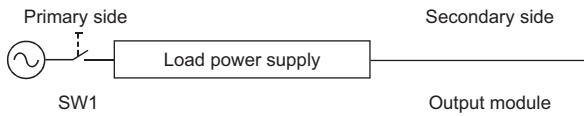

When installing the switch to the secondary side, connect a capacitor and resistor, and increase the time taken to power on the load power supply (10ms or more).

• Sink output

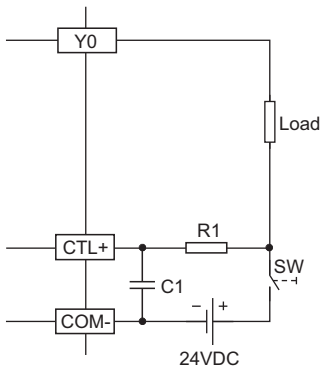

• Source output

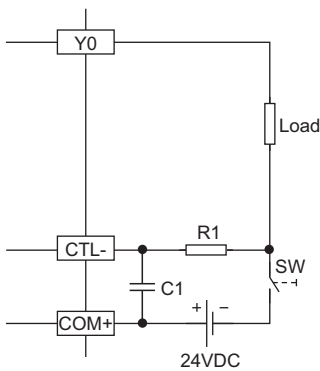

R1: Several tens of ohms

Power capacity $\geq (\text{Load power supply current}^{*1})^2 \times \text{Resistance value} \times (3 \text{ to } 5)^{*2}$

C1: Several hundreds of microfarads 50V

(Example)

R1 = 40Ω, C1 = 300μF

Time constant is calculated as shown below.

$$C1 \times R1 = 300 \times 10^{-6} \times 40$$

$$= 12 \times 10^{-3}\text{s}$$

$$= 12\text{ms}$$

*1 For the current consumption of the load power supply for the output part, refer to the manuals.

*2 Select the power capacity of resistor to be 3 to 5 times as large as the actual power consumption.

A load momentarily turns on from off when the system is powered off

■Cause

When an inductive load is connected, [2] Load may turn on from off due to a diversion of back electromotive force at [1] Shutoff.

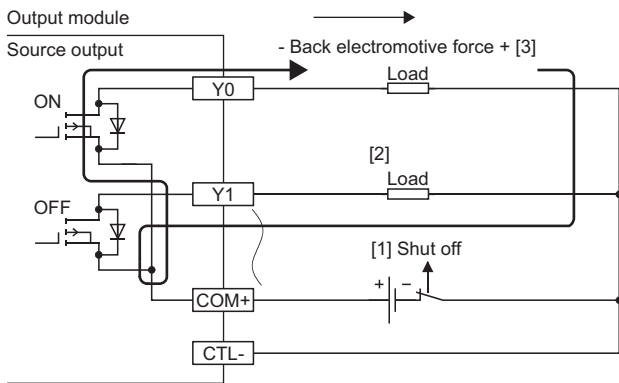
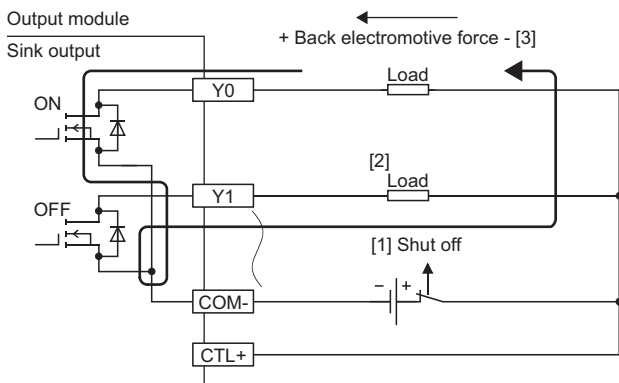

Action

Take one of two actions shown below.

- To suppress the back electromotive force, connect a diode parallel to the load where the back electromotive force has been generated.

[3]	
Sink output	Source output

- Provide another current path by connecting a diode across positive and negative of the load power supply. When taking the action described in Example 1 at a time, connect a diode parallel to C1 and R1.

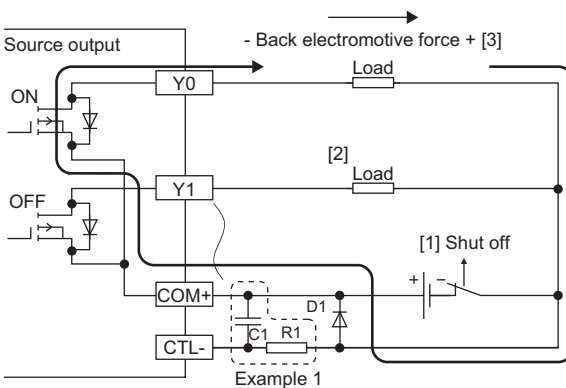
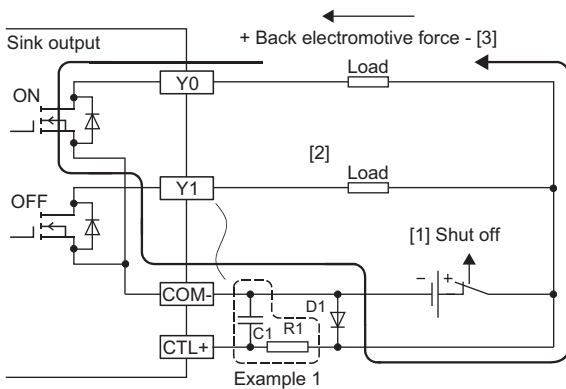

D1:

Reverse voltage V_R (VRM)^{*1}

Forward current I_F (IFM)^{*2}

*1 Approximately 10 times as large as the rated voltage in the specifications

Example: 24VDC → Approximately 200V

*2 Twice as much as the maximum load current (common) in the specifications or more

Example: 2A/1 common → 4A or more

When an LED is connected as a load, the LED lights dimly with the output module off

■Case

The load is operated by leakage current when the output module is off.

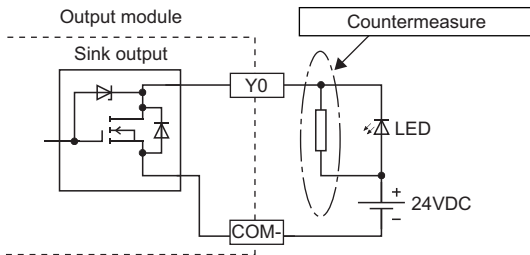

■Action

Connect a resistor of 5 to 50kΩ in parallel with the LED load.

When a digital display unit is connected as a load, the display may not be normal

■Case

The load is operated by leakage current when the output module is off.

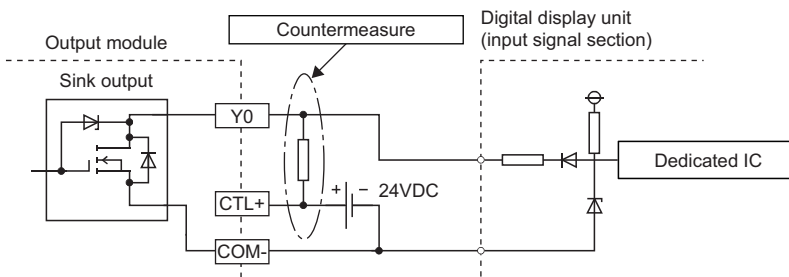

■Action

Install a pull-up resistor of 5 to 50kΩ and 0.5 (W) between the outputs of 24VDC power supply and the output module.

When an output is turned on, the load connected to other outputs is also turned on

■Case

When a non-wiring state occurs due to, for example, a shutoff or disconnection between 0V of the load power supply and the common of a load, a current flows across the load that is off through an unexpected circuit of the output element that is off.

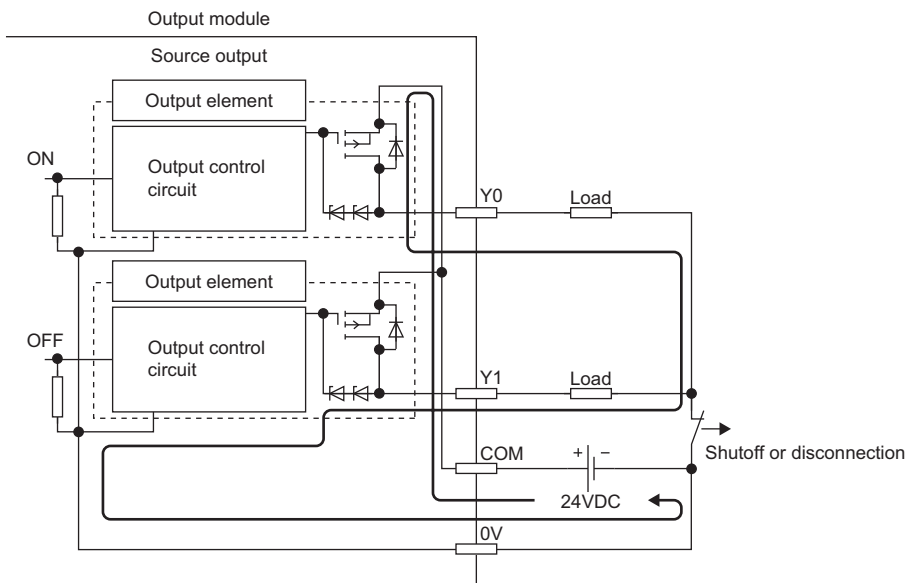

■Action

Connect the load power supply and the load properly.

To prevent the current from flowing across the load that is off, install a diode in each output terminal as shown below.

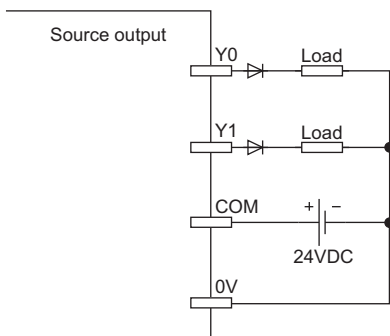

APPENDICES

Appendix 1 Details of Remote I/O Signals

The following describes the details of the remote I/O signals assigned to the master/local module.

The assignment of each device number is for the case when the remote I/O signals of the I/O module are assigned as follows.

Item	I/O module
Remote input signal	RX0 to RXF
Remote output signal	RY0 to RYF

Remote input signal

External input signal

This signal shows the on/off state of each of external inputs (X0 to XF) of the input module. However, when the input OFF delay function is enabled, the on/off state of each of the actual external inputs (X0 to XF) and that of External input signal X□ (RX0 to RXF) may not match. For details on the input OFF delay function, refer to the following.

☞ Page 84 Input OFF Delay Function

Remote output signal

External output signal

This signal turns on or off each of external outputs (Y0 to YF) of the output module. However, when the fast logic function is enabled, the on/off state of External output signal Y□ (RY0 to RYF) and that of each of the actual external outputs (Y0 to YF) may not match. For details on the fast logic function, refer to the following.

☞ Page 95 Fast Logic Function

Appendix 2 Details of Remote Registers

This section describes details of remote registers for a master/local module.

The described assignment of device numbers assumes that the remote registers of the I/O module are assigned to RWr0 to RWrB and RWw0 to RWwB.

Module status area

Initial processing request flag (RWr0.b8)

The operations of Initial processing request flag (RWr0.b8) and Initial processing completion flag (RWw0.b8) vary depending on the setting value of Initial operation setting (address: 0004H).

- When With initial processing (0) is set

After the module is powered on, Initial processing request flag (RWr0.b8) turns on. Create a program where initial processing is executed by using Initial processing request flag (RWr0.b8) and Initial processing completion flag (RWw0.b8). When Initial processing completion flag (RWw0.b8) is turned on, Remote READY (RWr0.b11) turns on. Also when Initial processing completion flag (RWw0.b8) is turned on, Initial processing request flag (RWr0.b8) turns off.

Point

When setting parameters using Initial processing request flag (RWr0.b8) as an interlock as shown in the program example, set Initial operation setting (address: 0004H) to With initial processing (0). After that, perform initial processing and check that Remote READY (RWr0.b11) is on.

For program examples of initial processing, refer to the following.

Page 116 Program example

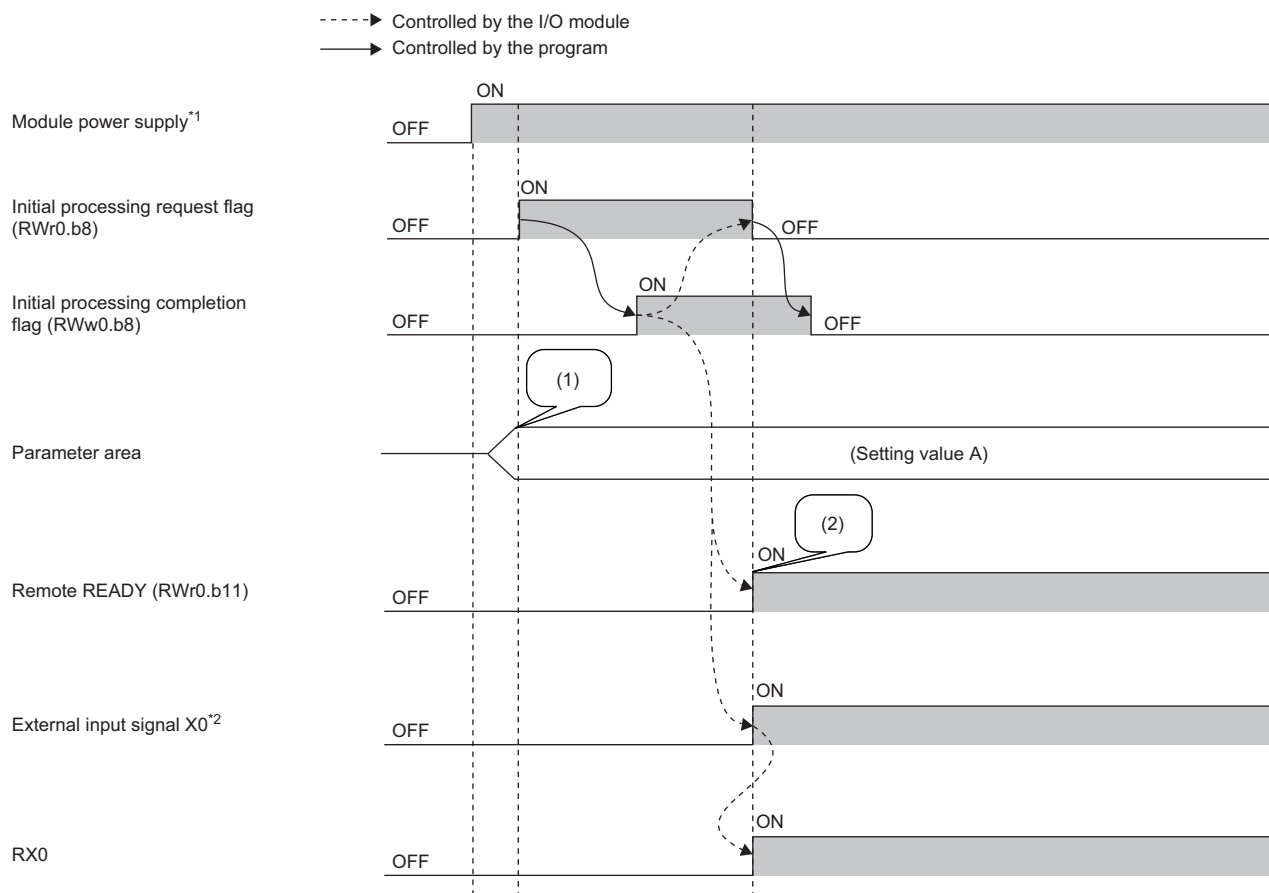

*1 When data link starts at the same time of when the module is powered on

*2 When an external input device connected to X0 is on

(1) Setting values are read from the internal nonvolatile memory.

(2) The operation starts with the setting value A.

- When Without initial processing (1) is set

Initial processing request flag (RWr0.b8) does not turn on. The I/O module becomes operable (the update of external I/O becomes enabled) without Initial processing completion flag (RWw0.b8) being turned on. When the module is powered on, Remote READY (RWr0.b11) turns on and the initial processing is completed.

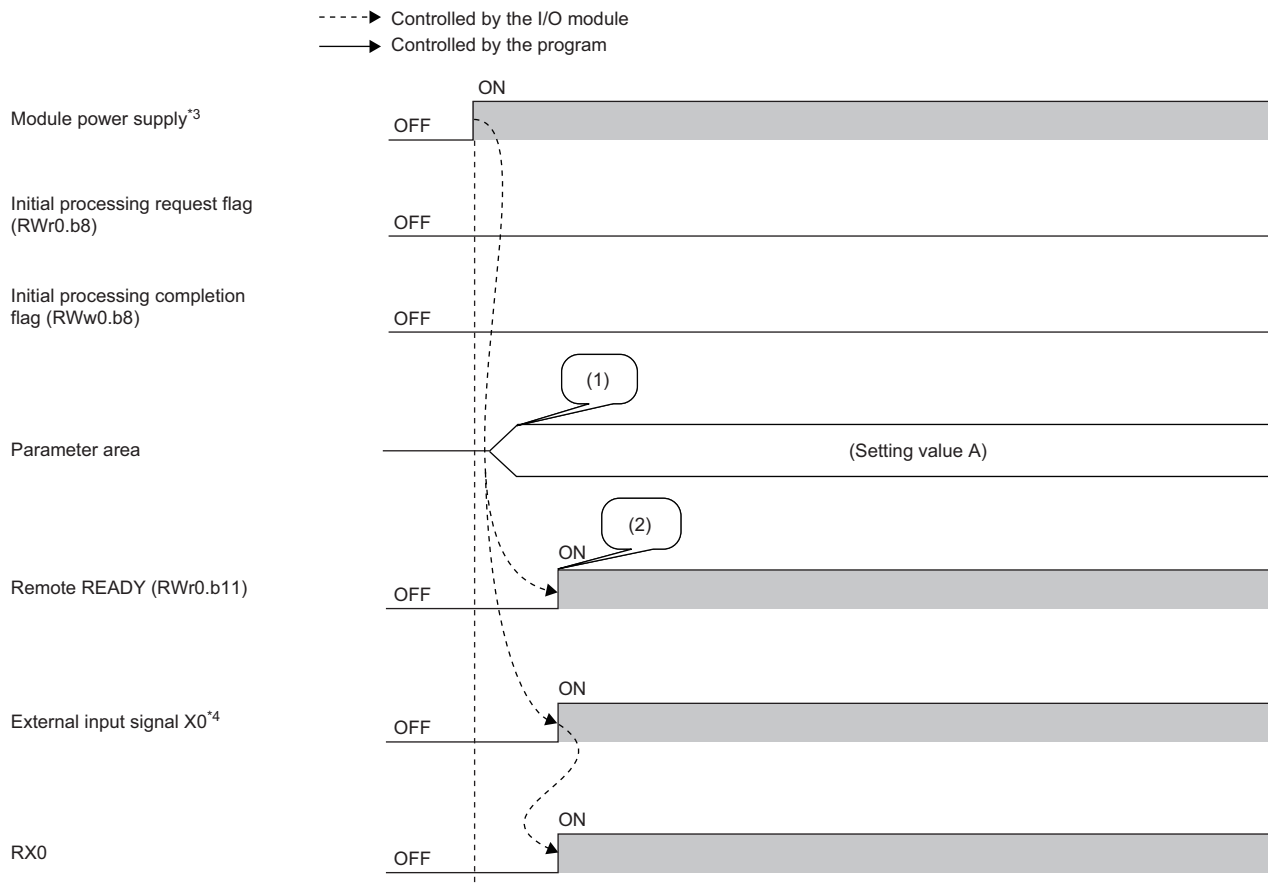

*3 When data link starts at the same time of when the module is powered on

*4 When an external input device connected to X0 is on

(1) Setting values are read from the internal nonvolatile memory.

(2) The operation starts with the setting value A.



■ Operation condition setting completion flag (RWr0.b9)

After writing parameter data to the remote buffer memory with the REMTO instruction, turn on Operation condition setting request flag (RWw0.b9). After the operating condition is changed, Operation condition setting completion flag (RWr0.b9) turns on. When the following settings are changed, the flag is used as a trigger condition to turn Operation condition setting request flag (RWw0.b9) on and off.

- Input response time setting (address: 0000H)
- Output HOLD/CLEAR setting (address: 0001H)
- Cyclic data update watch time setting (address: 0002H)
- Initial operation setting (address: 0004H)
- Number of ON times integration function enable (address: 0102H)
- Input OFF delay setting X□ (address: 0110H to 012FH)
- Fast logic setting Y□ (address: 0120H to 0127H)

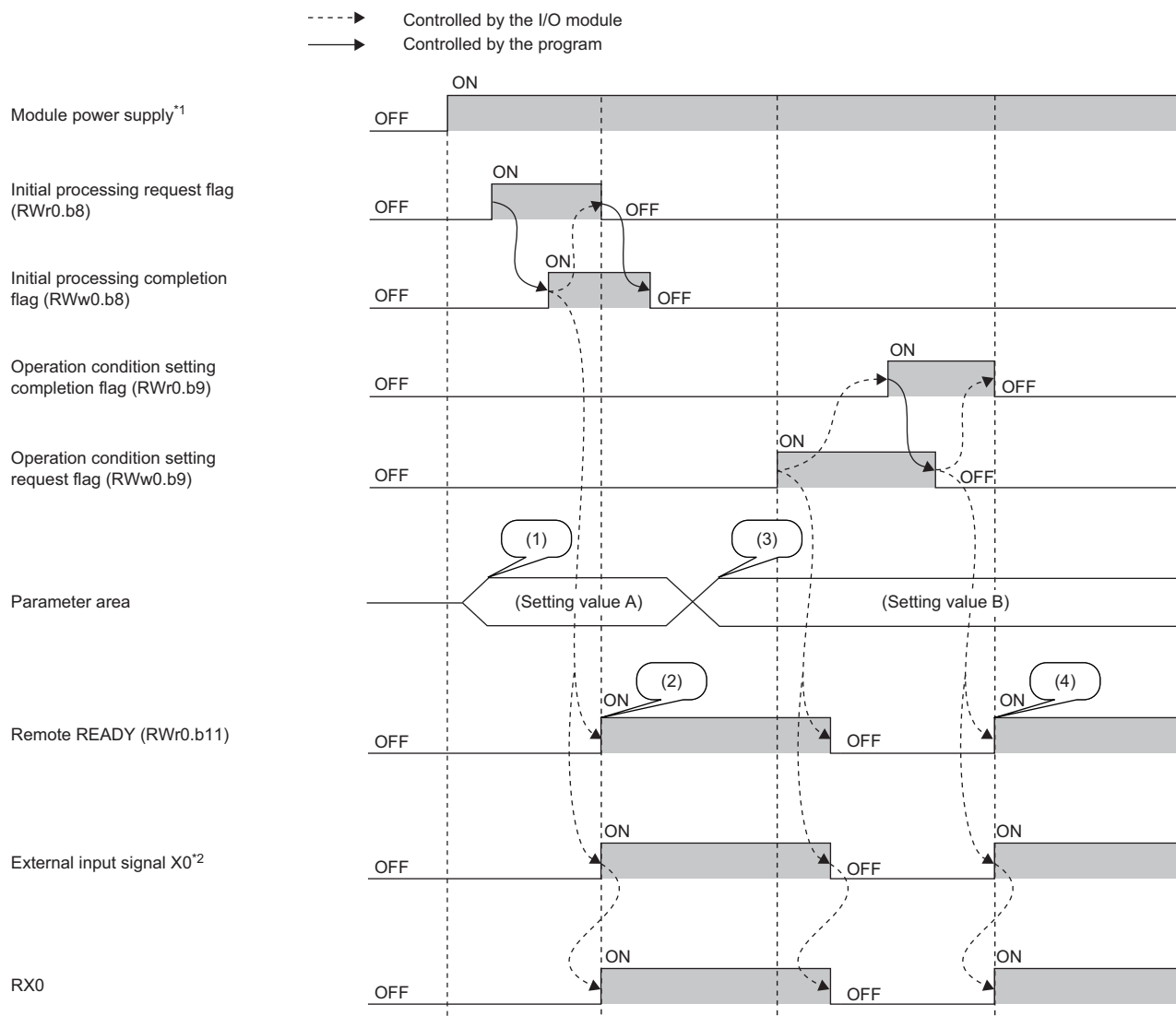

*1 When data link starts at the same time of when the module is powered on

*2 When an external input device connected to X0 is on

(1) Setting values are read from the internal nonvolatile memory.

(2) The operation starts with the setting value A.

(3) The setting value is changed by users.

(4) The operation starts with the parameter setting value B.

■ Error status flag (RWr0.b10)

Error status flag (RWr0.b10) turns on when a moderate error or major error occurs.

To clear Error code (RWr1), turn on and off Error clear request flag (RWw0.b10)).

- When a moderate error occurs

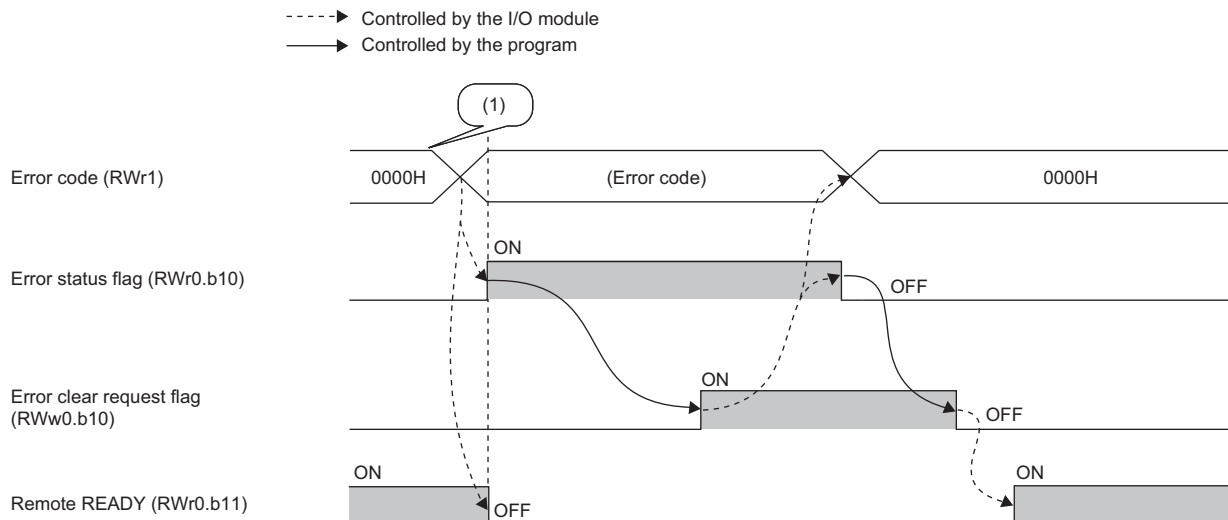

(1) An error occurs.

- When a major error occurs

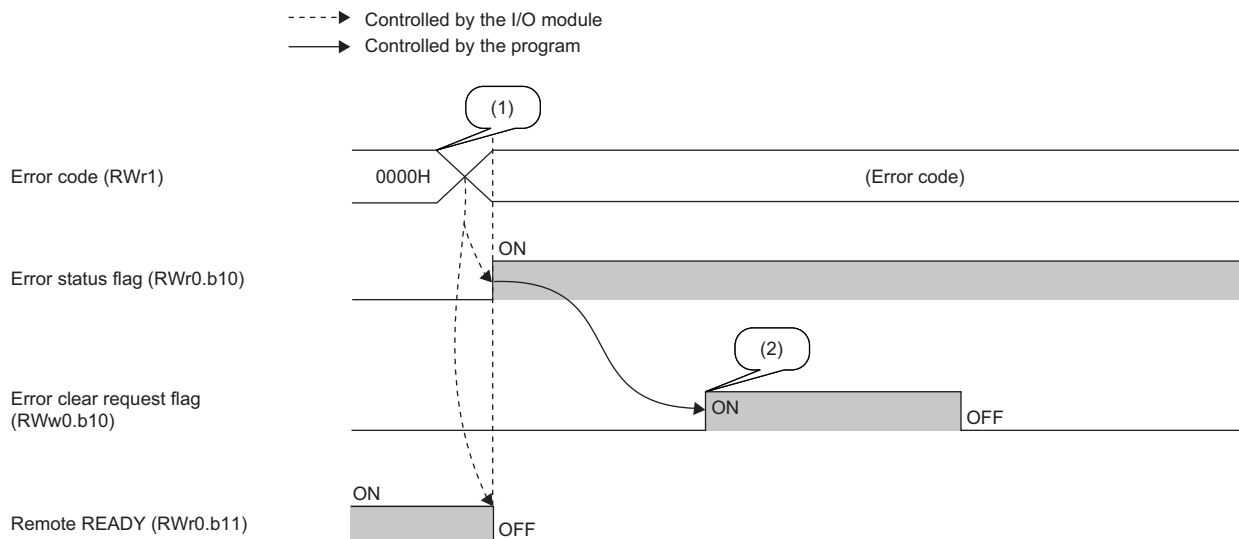

(1) An error occurs.

(2) When a major error has occurred, the error is not cleared even though an error clear request is issued.

■ Error history

The error history is not cleared even if Error clear request flag (RWw0.b10) is turned on and off. To clear the history, set "1" for Error history clear command (address: 1000H).

For the error history clear, refer to the following.

☞ Page 161 Error history clear command



■ Remote READY (RWr0.b11)

This signal is used as an interlock condition when the master station reads/writes data from/to the remote register or remote buffer memory areas of the I/O module.

With Initial operation setting (address: 0004H) being set to With initial processing (0), Remote READY (RWr0.b11) turns on when initial processing is completed after powering on of the module.

With Initial operation setting (address: 0004H) being set to Without initial processing (1), Remote READY (RWr0.b11) turns on after powering on of the module.

When Error status flag (RWr0.b10) turns on, Remote READY (RWr0.b11) turns off.

■ Warning status flag (RWr0.b12)

Warning status flag (RWr0.b12) turns on when a minor error occurs.

Five seconds after the cause of the minor error is eliminated, the value in Warning code (RWr2) is cleared automatically (0000H is stored) and Warning status flag (RWr0.b12) turns off.

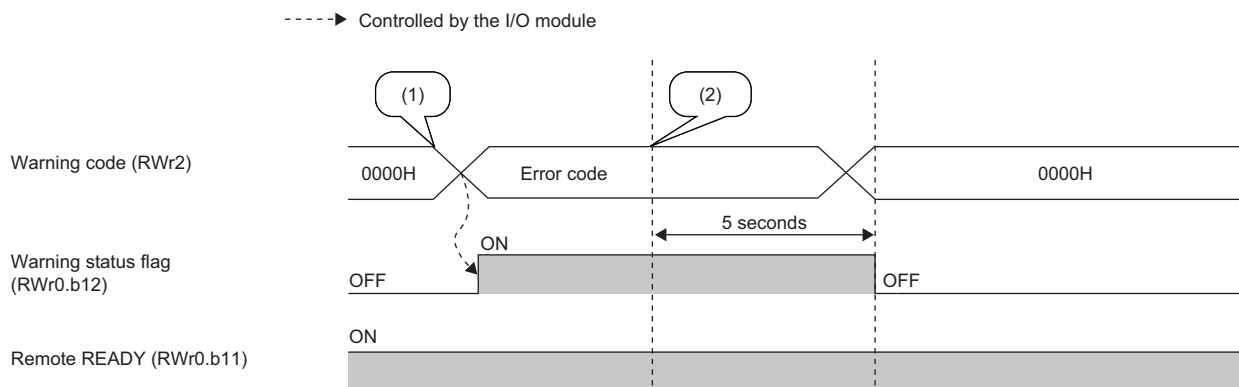

(1) A minor error occurs.

(2) The minor error is cleared.

Error code

An error code is stored into RWr1 when a moderate error or major error occurs.

Turning on Error clear request flag (RWw0.b10) after eliminating the cause of the error clears the error code.

Errors that occurred in the past can be checked with Error history data \square (address: 0A00H to 0AEFH). For error history, refer to the following.

☞ Page 159 Error history data

Warning code

The error code is stored into RWr2 when a minor error occurs.

Five seconds after the cause of the minor error is eliminated, the error code is automatically cleared.

Errors that occurred in the past can be checked with Error history data \square (address: 0A00H to 0AEFH). For error history, refer to the following.

☞ Page 159 Error history data

Function selection status flag

■ Power supply monitor state flag (RW_r3.b₀)

When the power supply monitoring function is enabled by Power supply monitor request flag (RW_w3.b₀), this flag is on.

-----► Controlled by the I/O module

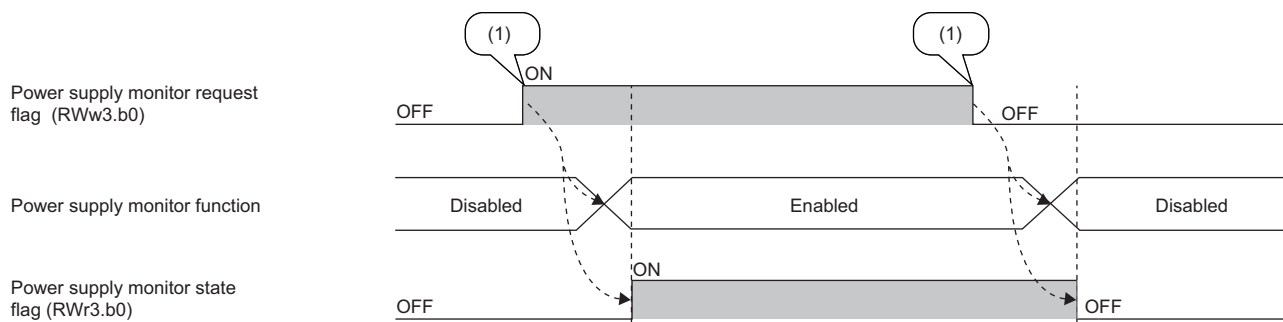

(1) Changed by users

For the power supply monitoring function, refer to the following.

☞ Page 92 Power Supply Monitoring Function

Input X port status

When a short circuit is detected in a set of two sensor power supplies, Input X port status turns on. The LEDs of the two sensor power supplies of the set in which the short circuit was detected turn on in red.

Input X port status is assigned to each input port for two sensor power supplies.

■ Input X port status PS₀ to PS₇ (RW_r4)

b ₁₅	b ₁₄	b ₁₃	b ₁₂	b ₁₁	b ₁₀	b ₉	b ₈	b ₇ ^{*1}	b ₆ ^{*1}	b ₅ ^{*1}	b ₄ ^{*1}	b ₃	b ₂	b ₁	b ₀
0 (fixed)								PS ₇	PS ₆	PS ₅	PS ₄	PS ₃	PS ₂	PS ₁	PS ₀

When PS₀ is off: No short circuit has been detected in X₀ and X₁.

When PS₀ is on: A short circuit has been detected in X₀ or X₁.

When PS₁ is off: No short circuit has been detected in X₂ and X₃.

When PS₁ is on: A short circuit has been detected in X₂ or X₃.

⋮

When PS₇ is off: No short circuit has been detected in X_E and X_F.

When PS₇ is on: A short circuit has been detected in X_E or X_F.

*1 The use of these bits is prohibited for the NZ2GF12A42-16DT and NZ2GF12A42-16DTE.

When a short circuit in a set of two sensor power supplies is eliminated and the two sensor power supplies in the port return to their normal conditions, Input X port status for the port turns off and the LEDs of the two sensor power supplies turn on in green.

Output Y channel status

When a short circuit is detected in an external device, Output Y channel status turns on. The LED of the output signal in which the short circuit was detected turns on in red.

■ Output Y channel status CS₀ to CS_F (RW_r5)

b ₁₅	b ₁₄	b ₁₃	b ₁₂	b ₁₁	b ₁₀	b ₉	b ₈	b ₇ ^{*1}	b ₆ ^{*1}	b ₅ ^{*1}	b ₄ ^{*1}	b ₃ ^{*1}	b ₂ ^{*1}	b ₁ ^{*1}	b ₀ ^{*1}
CS _F	CSE	CSD	CSC	CSB	CSA	CS ₉	CS ₈	CS ₇	CS ₆	CS ₅	CS ₄	CS ₃	CS ₂	CS ₁	CS ₀

When CS₀ is off: No short circuit has been detected in Y₀.

When CS₀ is on: A short circuit has been detected in Y₀.

When CS₁ is off: No short circuit has been detected in Y₁.

When CS₁ is on: A short circuit has been detected in Y₁.

⋮

When CS_F is off: No short circuit has been detected in Y_F.

When CS_F is on: A short circuit has been detected in Y_F.

*1 The use of these bits is prohibited for the NZ2GF12A42-16DT and NZ2GF12A42-16DTE.

When a short circuit in the output signal is eliminated, Output Y channel status for the output signal is turned off and the LED of the output signal turns on in green.

Output Y current value

- The actual on/off state of the output Y can be checked by using Output Y current value (RW_r6).
- When the fast logic function is used on the I/O combined module, the output Y is controlled according to the operation result of the inside of the module, not by the remote output signal (RY) received from the master station.
- Output Y current value (RW_r6) can always be used. (The status is stored even when the fast logic function is not used.)

Output Y current value Y0 to YF (RW_r6)

b15	b14	b13	b12	b11	b10	b9	b8	b7*1	b6*1	b5*1	b4*1	b3*1	b2*1	b1*1	b0*1
YF	YE	YD	YC	YB	YA	Y9	Y8	Y7	Y6	Y5	Y4	Y3	Y2	Y1	Y0

Off: The output Y is off.

On: The output Y is on.

*1 The use of these bits is prohibited for the NZ2GF12A42-16DT and NZ2GF12A42-16DTE.

Output Y ON information

Whether the output Y has been turned on can be checked with Output Y ON information (RW_r7).

Output Y ON information Y0 to YF (RW_r7)

b15	b14	b13	b12	b11	b10	b9	b8	b7*1	b6*1	b5*1	b4*1	b3*1	b2*1	b1*1	b0*1
YF	YE	YD	YC	YB	YA	Y9	Y8	Y7	Y6	Y5	Y4	Y3	Y2	Y1	Y0

Off: The output Y has never been turned on.

On: The output Y has been turned on.

*1 The use of these bits is prohibited for the NZ2GF12A42-16DT and NZ2GF12A42-16DTE.

Output Y ON information (RW_r7) can be cleared using Output Y ON information clear request (RW_w7).

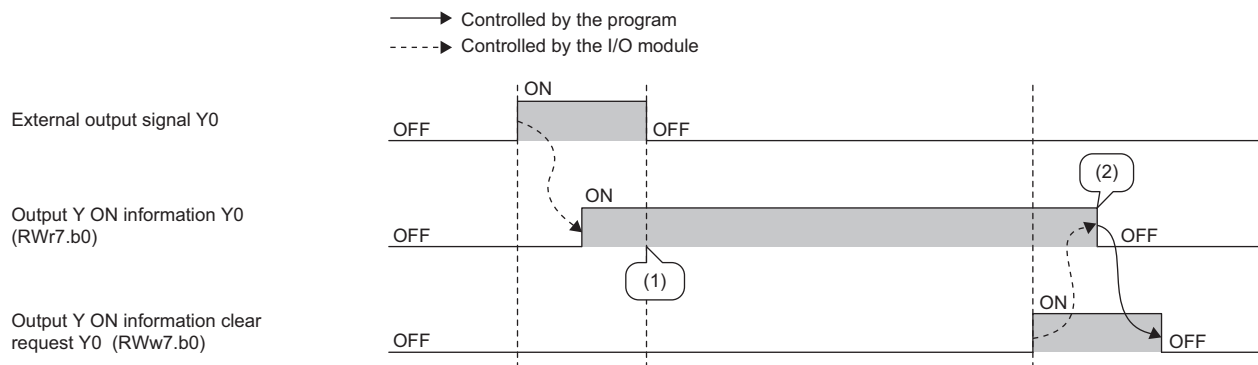

(1) This remote register remains on after Y0 is turned off.

(2) This remote register is turned off after the clear request is turned on.

Output Y OFF information

Whether the output Y has been turned off can be checked with Output Y OFF information (RWr8).

■ Output Y OFF information Y0 to YF (RWr8)

b15	b14	b13	b12	b11	b10	b9	b8	b7*1	b6*1	b5*1	b4*1	b3*1	b2*1	b1*1	b0*1
YF	YE	YD	YC	YB	YA	Y9	Y8	Y7	Y6	Y5	Y4	Y3	Y2	Y1	Y0

Off: The output Y has never been turned off.

On: The output Y has been turned off.

*1 The use of these bits is prohibited for the NZ2GF12A42-16DT and NZ2GF12A42-16DTE.

Output Y OFF information (RWr8) can be cleared using Output Y OFF information clear request (RWw8).

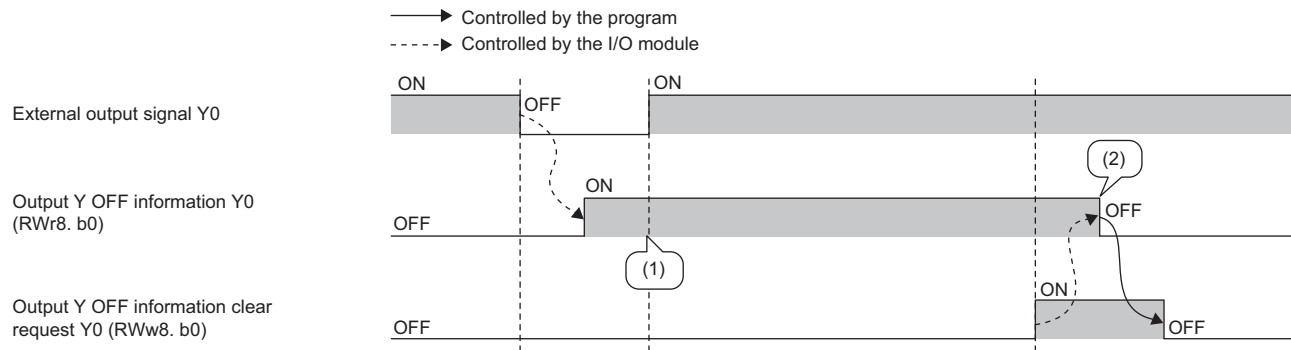

(1) This remote register remains on after Y0 is turned on.

(2) This remote register is turned off after the clear request is turned on.

Module operation area

■Initial processing completion flag (RWw0.b8)

Turning on this flag completes the initial processing and turns on Remote READY (RWr0.b11).

For the timing of turning the flag on and off, refer to the following.

☞ Page 144 Initial processing request flag (RWr0.b8)

■Operation condition setting request flag (RWw0.b9)

After writing parameter data to the remote buffer memory, turn on Operation condition setting request flag (RWw0.b9). After the operating condition is changed, Operation condition setting completion flag (RWr0.b9) turns on.

For the timing of turning the flag on and off, refer to the following.

☞ Page 146 Operation condition setting completion flag (RWr0.b9)

Point

- Turning on Operation condition setting request flag (RWw0.b9) stores zero in Warning code (RWr2) and turns off Warning status flag (RWr0.b12).
- When a major error or a moderate error occurs and the error cause is eliminated, turning on Operation condition setting request flag (RWw0.b9) stores zero in Error code (RWr1) and turns off Error status flag (RWr0.b10).

■Error clear request flag (RWw0.b10)

Use this flag to clear Error status flag (RWr0.b10) and Error code (RWr1).

- When a moderate error occurs

When Error clear request flag (RWw0.b10) is turned on after the cause of the error is eliminated, the error status is cleared and Error status flag (RWr0.b10) turns off.

If Error clear request flag (RWw0.b10) is turned off before Error status flag (RWr0.b10) turns off, Error status flag (RWr0.b10) does not turn off.

For the timing of turning the flag on and off, refer to the following.

Error status flag (RWr0.b10) (☞ Page 147 Error status flag (RWr0.b10))

- When a major error occurs

Error status flag (RWr0.b10) does not turn off even if Error clear request flag (RWw0.b10) is turned on and off.

For the timing of turning the flag on and off, refer to the following.

Error status flag (RWr0.b10) (☞ Page 147 Error status flag (RWr0.b10))

Function selection setting flag

■Power supply monitor request flag (RWw3.b0)

To enable the power supply monitoring function, turn on this flag. For the timing of turning the flag on and off, refer to the following.

☞ Page 149 Power supply monitor state flag (RWr3.b0)

Output Y ON information clear request

This remote register is used to clear Output Y ON information (RWr7).

Clear processing continues while the bit of Output Y ON information clear request (RWw7) is on.

■Output Y ON information clear request Y0 to YF (RWw7)

b15	b14	b13	b12	b11	b10	b9	b8	b7*1	b6*1	b5*1	b4*1	b3*1	b2*1	b1*1	b0*1
YF	YE	YD	YC	YB	YA	Y9	Y8	Y7	Y6	Y5	Y4	Y3	Y2	Y1	Y0

Off: Output Y ON information is not cleared.

On: Output Y ON information is cleared.

*1 The use of these bits is prohibited for the NZ2GF12A42-16DT and NZ2GF12A42-16DTE.

For the timing of turning the register on and off, refer to the following.

☞ Page 150 Output Y ON information

Output Y OFF information clear request

This remote register is used to clear Output Y OFF information (RW_r8).

Clear processing continues while the bit of Output Y OFF information clear request (RW_w8) is on.

■ Output Y OFF information clear request Y0 to YF (RW_w8)

b15	b14	b13	b12	b11	b10	b9	b8	b7 ^{*1}	b6 ^{*1}	b5 ^{*1}	b4 ^{*1}	b3 ^{*1}	b2 ^{*1}	b1 ^{*1}	b0 ^{*1}
YF	YE	YD	YC	YB	YA	Y9	Y8	Y7	Y6	Y5	Y4	Y3	Y2	Y1	Y0

Off: Output Y OFF information is not cleared.

On: Output Y OFF information is cleared.

*1 The use of these bits is prohibited for the NZ2GF12A42-16DT and NZ2GF12A42-16DTE.

For the timing of turning the register on and off, refer to the following.

 Page 151 Output Y OFF information

Appendix 3 Details of Remote Buffer Memory Addresses

This section describes the details of remote buffer memory addresses of the I/O module.

Input response time setting

Set the input response time of the input module.

Input response time	Setting value
0ms	0H
0.5ms	1H
1.0ms	2H
1.5ms	3H
5ms	4H
10ms	5H
20ms	6H
70ms	7H

Remote buffer memory address

Name	Address
Input response time setting	0000H

Enabling the setting

Turn on and off Operation condition setting request flag (RWw0.b9) to enable the setting.

Default value

The default value is 10ms (5H).

Output HOLD/CLEAR setting

Set whether to hold or clear the last status of each output for when the I/O module is disconnected from data link or the CPU module is in STOP status.

Output HOLD/CLEAR setting	Setting value
CLEAR	0H
HOLD	1H

Remote buffer memory address

Name	Address
Output HOLD/CLEAR setting	0001H

Enabling the setting

Turn on and off Operation condition setting request flag (RWw0.b9) to enable the setting.

Default value

The default value is CLEAR (0H).

Cyclic data update watch time setting

Set the time to monitor the update intervals of cyclic transmission data (watch time).

When the cyclic transmission remains stopped longer than the cyclic data update watch time, the I/O module is regarded as disconnected from data link and the output status is held or cleared by Output HOLD/CLEAR setting (address: 0001H). For Output HOLD/CLEAR setting (address: 0001H), refer to the following.

 Page 154 Output HOLD/CLEAR setting

Remote buffer memory address

Name	Address
Cyclic data update watch time setting	0002H

Setting range

Setting range is Not monitor (0) or 0.1 to 2s (1 to 20). Set the values in increments of 100ms (1).

Enabling the setting

Turn on and off Operation condition setting request flag (RWw0.b9) to enable the setting.

Default value

The default value is Not monitor (0).

Point

If a value out of the setting range above is set, the error code (0504H) is stored in Error code (RWr1), Error status flag (RWr0.b10) turns on, and the ERR. LED turns on. Then the I/O module stops the I/O operation.

Initial operation setting

Set whether the initial processing using the program is necessary or not when the data link is established.

Initial operation setting	Description	Setting value
With initial processing	Set it when the initial processing using the program is necessary. <ul style="list-style-type: none">When the data link is established, Initial processing request flag (RWr0.b8) turns on.When Initial processing completion flag (RWw0.b8) is turned on, Initial processing request flag (RWr0.b8) turns off and Remote READY (RWr0.b11) turns on.The external I/O function of the I/O module cannot be used until initial processing is completed.	0
Without initial processing	Set it when the initial processing using the program is not necessary. <ul style="list-style-type: none">When the data link is established, Remote READY (RWr0.b11) turns on.At the data link establishment, the external I/O function of the I/O module becomes enabled.	1

Remote buffer memory address

Name	Address
Initial operation setting	0004H

Enabling the setting

Turn on and off Operation condition setting request flag (RWw0.b9) to enable the setting.

Default value

The default value is Without initial processing (1).

Point

When setting parameters using Initial processing request flag (RWr0.b8) as an interlock as shown in the program example, set Initial operation setting (address: 0004H) to With initial processing (0). After that, perform initial processing and check that Remote READY (RWr0.b11) is on.
For program examples of initial processing, refer to the following.

 Page 116 Program example

Number of ON times integration function enable

Set whether to enable or disable the number of ON times integration function.

b15	b14	b13	b12	b11	b10	b9	b8	b7*1	b6*1	b5*1	b4*1	b3*1	b2*1	b1*1	b0*1
YF	YE	YD	YC	YB	YA	Y9	Y8	Y7	Y6	Y5	Y4	Y3	Y2	Y1	Y0

0: Disable

1: Enable

*1 The use of these bits is prohibited for the NZ2GF12A42-16DT and NZ2GF12A42-16DTE.

Remote buffer memory address

Name	Address
Number of ON times integration function enable	0102H

Enabling the setting

Turn on and off Operation condition setting request flag (RWw0.b9) to enable the setting.

Default value

The default value is Disable (0).

Input OFF delay setting

Set whether to enable or disable the input OFF delay function and set the delay time.

Input OFF delay setting X0 (address: 0110H to 0111H)

Address	b15	b14	b13	b12	b11	b10	b9	b8	b7	b6	b5	b4	b3	b2	b1	b0
0110H	Lower 16 bits of delay time															
0111H	Higher 16 bits of delay time															

Remote buffer memory address

Name	Address
Input OFF delay setting X0	0110H to 012FH*1

*1 The use of 0120H to 012FH is prohibited for the NZ2GF12A42-16DT and NZ2GF12A42-16DTE.

Setting range

Setting range is No delay (0) or 400μs to 60s (1 to 150000). Set the values in increments of 400μs.

Enabling the setting

Turn on and off Operation condition setting request flag (RWw0.b9) to enable the setting.

Default value

The default value is No delay (0).

Point

If a value out of the setting range above is set, the error code (0503H) is stored in Error code (RWr1), Error status flag (RWr0.b10) turns on, and the ERR. LED turns on. Then the I/O module stops the I/O operation.

Fast logic setting

Set whether to enable or disable the fast logic function where the fixed output conditions are assigned in each remote buffer memory address.

The fast logic function can be used for the I/O combined module.

Fast logic setting Y8 (address: 0120H to 0121H)

Address	b15	b14	b13	b12	b11	b10	b9	b8	b7	b6	b5	b4	b3	b2	b1	b0
0120H	0 (fixed)															
0121H	(1)	0 (fixed)														

(1) 0: Disable, 1: Enable

Remote buffer memory address

Name	Address
Fast logic setting Y□	0120H to 0127H

Combinations of output conditions and input signals for each output signal

- X0 to X7: Input signals of the I/O combined module
- Y8 to YB: Output signals of the I/O combined module

Item	Logic (output condition)	Output signal Y□	Input signal A	Input signal B
Fast logic setting Y8	AND (When both the input signal A and B turn on, Output signal Y□ is output.)	Y8	X0	X1
Fast logic setting Y9		Y9	X2	X3
Fast logic setting YA	OR (When either of the input signal A or B turns on, Output signal Y□ is output.)	YA	X4	X5
Fast logic setting YB		YB	X6	X7

Enabling the setting

Turn on and off Operation condition setting request flag (RWw0.b9) to enable the setting.

Default value

The default value is Disable (0).



Because Fast logic setting Y□ (address: 0120H to 0127H) is not written to the nonvolatile memory, the parameters must be written again after the module is powered off and on.

Fast logic enable status

The fast logic enable or disable status for each signal is stored.

The fast logic function can be used for the I/O combined module.

b15	b14	b13	b12	b11	b10	b9	b8	b7	b6	b5	b4	b3	b2	b1	b0
0 (fixed)				0: Disable 1: Enable				0 (fixed)							

Remote buffer memory address

Name	Address
Fast logic enable status	0602H

Number of ON times integration value

The integration value of the number of ON times integration function is stored as signed 32-bit binary.

■Remote buffer memory address

Name	Output	Address
Number of ON times integration value Y□	Y0 ^{*1}	0610H
	Y1 ^{*1}	0612H
	Y2 ^{*1}	0614H
	Y3 ^{*1}	0616H
	Y4 ^{*1}	0618H
	Y5 ^{*1}	061AH
	Y6 ^{*1}	061CH
	Y7 ^{*1}	061EH
	Y8	0620H
	Y9	0622H
	YA	0624H
	YB	0626H
	YC	0628H
	YD	062AH
	YE	062CH
	YF	062FH

*1 The use of these outputs is prohibited for the NZ2GF12A42-16DT and NZ2GF12A42-16DTE.

Error history data

Up to 15 errors generated in the module are recorded.

The following table and figure show the storage data for Error history data 1 (address: 0A00H to 0A0FH).

■Error history data 1 (address: 0A00H to 0A0FH)

Address	b15	b14	b13	b12	b11	b10	b9	b8	b7	b6	b5	b4	b3	b2	b1	b0
0A00H	Error code															
0A01H	Order of generation															
0A02H	First two digits of the year								Last two digits of the year							
0A03H	Month								Day							
0A04H	Hour								Minute							
0A05H	Second								00H (fixed)							
0A06H	Error code details 1															
0A07H	Error code details 2															
0A08H	Error code details 3															
0A09H	Error code details 4															
:	:															
0A0FH	Error code details 10															

Ex.

The following table lists data to be stored and storage examples of each item of error history data.

Item	Description	Storage example ^{*1}
Error code	The code of an error that has occurred is stored.	—
Order of generation	The order of error occurrence is stored. (The value of 0H to FFFFH is stored.)	0001H
First two digits of the year/Last two digits of the year ^{*2}	The items on the left are stored in BCD code.	2012H
Month/Date ^{*2}		0901H
Hour/Minute ^{*2}		1330H
Second ^{*2}		5000H
Error code details 1	The detailed information of some errors is stored. The data to be stored depend on the error. (☞ Page 160 Error code details)	—
Error code details 2		—
Error code details 3		—
Error code details 4 : Error code details 10	0 (fixed)	0

*1 Those values are for when the second error occurs at 13:30:50, September 1st, 2012.

*2 The clock information of the error that occurred is based on the clock information acquired from the CPU module of the master station.
When an error has occurred before the clock information is acquired from the CPU module, the error time is not recorded.

■Remote buffer memory address

Name	Address
Error history data □	0A00H to 0AEFH

Error history data 2 to Error history data 15 (address: 0A10H to 0AEFH) are stored in the same format as that of Error history data 1 (address: 0A00H to 0A0FH).

For the error code, refer to the following.

☞ Page 124 Error Code List

■Storage order of the error history

The latest error is stored in Error history data 1 (address: 0A00H to 0A0FH).

Errors that occurred in the past are stored in Error history data 2 to Error history data 15 (address: 0A10H to 0AEFH) in reverse chronological order.

■ Error code details

For the following errors, each of additional error information is stored in Error code details □ (address: 0A06H to 0A0FH)*1.

*1 The following table describes Error code details □ for Error history data 1 (address: 0A00H to 0A0FH).

Error		Information to be stored			
Error code (hexadecimal)	Error name	Error code details 1 (address: 0A06H)	Error code details 2 (address: 0A07H)	Error code details 3 (address: 0A08H)	Error code details 4 to Error code details 10 (address: 0A09H to 0A0FH)
0103H	Power supply voltage error	Error cause*2	0 (fixed)	0 (fixed)	0 (fixed)
0202H	Remote buffer memory access error	Start address of the remote buffer memory specified with REMFR/ REMTO	0 (fixed)	0 (fixed)	
0503H	Parameter data error (input OFF delay)	Remote buffer memory address of the parameter in which an error is detected (Input OFF delay setting X□ (address: 0110H to 012FH))	The value written to the corresponding address is stored. Check that the value is within the range of the input OFF delay setting (0 to 150000).		
0504H	Parameter data error (cyclic data update watch time setting)	Remote buffer memory address of the parameter in which an error is detected (Cyclic data update watch time setting (address: 0002H))	The value written to the corresponding address is stored. Check that the value is within the range of the cyclic data update watch time setting (0 to 20).	0 (fixed)	
0506H	Parameter data error (initial operation setting)	Remote buffer memory address of the parameter in which an error is detected (Initial operation setting (address: 0004H))	The value written to the corresponding address is stored.	0 (fixed)	

*2 For the storage data of an error cause, refer to the following.

☞ Page 160 Error history data of when a power supply voltage error occurs

■ Error history data of when a power supply voltage error occurs

Information of the module that has detected a power supply voltage error is stored in Error code details 1 of Error history data □ (address: 0A00H to 0AEFH). (The following is an example of Error history data 1 (address: 0A00H to 0A0FH).)

b15	b14	b13	b12	b11	b10	b9	b8	b7	b6	b5	b4	b3	b2	b1	b0
0 (fixed)												(4)	(3)	(2)	(1)

(1) 0: The module-and-sensor power supply has no low-voltage error., 1: The module-and-sensor power supply has a low-voltage error.

(2) 0: The module-and-sensor power supply has no overvoltage error., 1: The module-and-sensor power supply has an overvoltage error.

(3) 0: The load power supply has no low-voltage/power-off error., 1: The load power supply has a low-voltage/power-off error.

(4) 0: The load power supply has no overvoltage error., 1: The load power supply has an overvoltage error.

Error history clear command

The error history stored in the module is cleared.

b15	b14	b13	b12	b11	b10	b9	b8	b7	b6	b5	b4	b3	b2	b1	b0
0 (fixed)															(1)

(1) 0: Not commanded, 1: Commanded

Remote buffer memory address

Name	Address
Error history clear command	1000H

Operation of error history clear

When Error history clear command (address: 1000H) is set to Commanded (1), an error history is cleared.

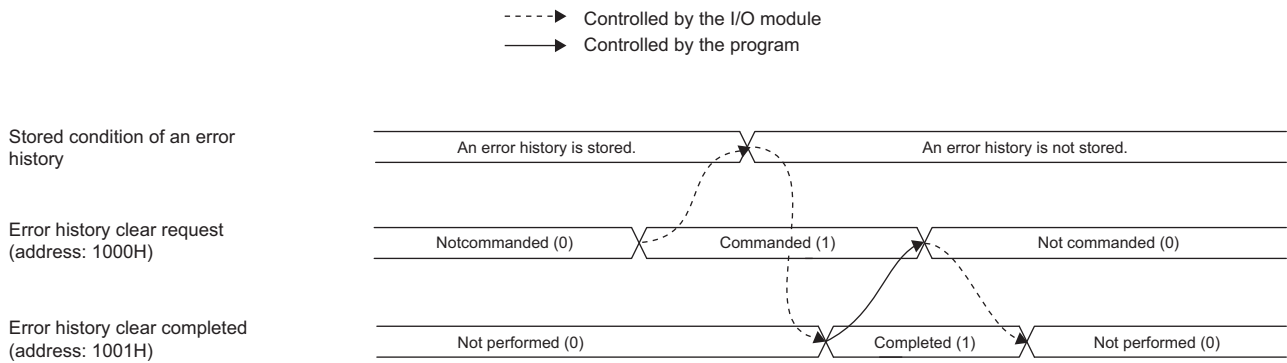

Default value

The default value is Not commanded (0).

Error history clear completed

This remote buffer memory area shows whether the error history stored in the module is cleared or not.

b15	b14	b13	b12	b11	b10	b9	b8	b7	b6	b5	b4	b3	b2	b1	b0
0 (fixed)															(1)

(1) 0: Not performed, 1: Completed

Remote buffer memory address

Name	Address
Error history clear completed	1001H

Operation of error history clear

When the error history clear is completed, Error history clear completed (address: 1001H) is turned to Completed (1).

For the timing of turning the bit to Not performed (0) → Completed (1) → Not performed (0), refer to the following.

☞ Page 161 Error history clear command

Default value

The default value is Not performed (0).

Parameter area initialization command

Set the parameters stored in a remote buffer memory and nonvolatile memory to the default value.

The module can be restored using this command when Nonvolatile memory data error (parameter) occurs.

b15	b14	b13	b12	b11	b10	b9	b8	b7	b6	b5	b4	b3	b2	b1	b0
0 (fixed)															(1)

(1) 0: Not commanded, 1: Commanded

Remote buffer memory address

Name	Address
Parameter area initialization command	1002H

Operation of the parameter area initialization

When Parameter area initialization command (address: 1002H) is set to Commanded (1), the parameters stored in a nonvolatile memory is set to the default value.

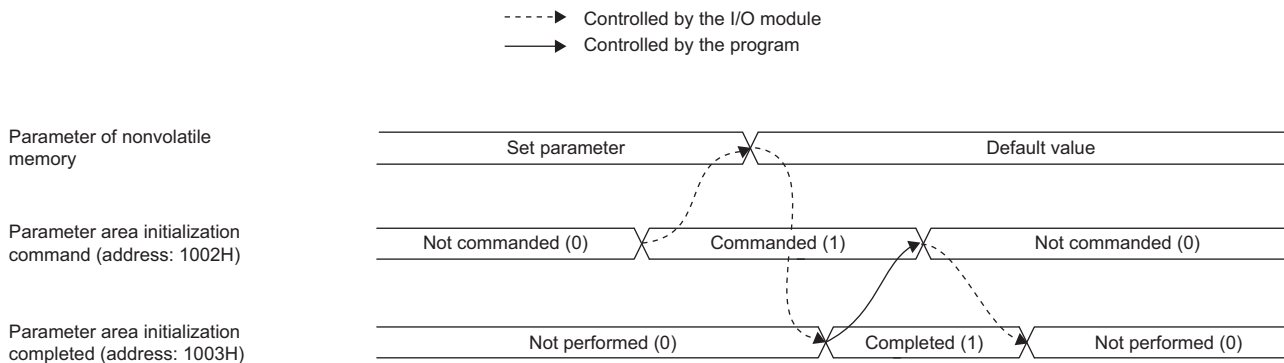

Default value

The default value is Not commanded (0).



After the parameters in a nonvolatile memory are set to the default value, the I/O module operates with the parameters of the default value.

Parameter area initialization completed

This remote buffer memory area shows whether initialization of the parameters stored in a nonvolatile memory is completed or not.

b15	b14	b13	b12	b11	b10	b9	b8	b7	b6	b5	b4	b3	b2	b1	b0
0 (fixed)															(1)

(1) 0: Not performed, 1: Completed

Remote buffer memory address

Name	Address
Parameter area initialization completed	1003H

Operation of the parameter area initialization

When the initialization of the parameters stored in a nonvolatile memory is completed, Parameter area initialization completed (address: 1003H) is turned Completed (1).

For the timing of turning the bit to Not performed (0) → Completed (1) → Not performed (0), refer to the following.

☞ Page 162 Parameter area initialization command

Default value

The default value is Not performed (0).

Module operation information initialization command

The module operation information stored in a nonvolatile memory is initialized.

The module operation information can be initialized only when Nonvolatile memory data error (module operation information) has occurred.

b15	b14	b13	b12	b11	b10	b9	b8	b7	b6	b5	b4	b3	b2	b1	b0
0 (fixed)															(1)

(1) 0: Not commanded, 1: Commanded

Remote buffer memory address

Name	Address
Module operation information initialization command	1004H

Operation of the module operation information initialization

When Module operation information initialization command (address: 1004H) is set to Commanded (1), the module information is initialized.

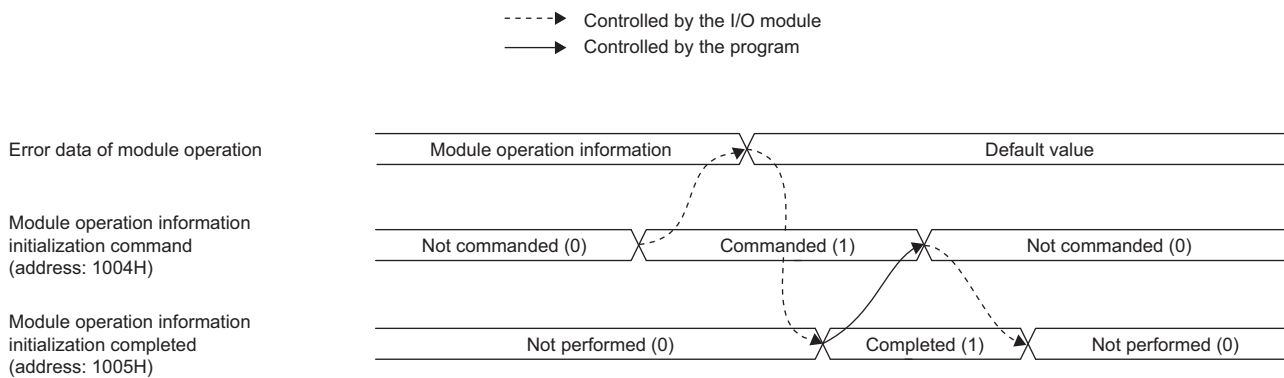

Default value

The default value is Not commanded (0).

Module operation information initialization completed

This remote buffer memory area shows whether initialization of the module operation information stored in a nonvolatile memory is completed or not.

b15	b14	b13	b12	b11	b10	b9	b8	b7	b6	b5	b4	b3	b2	b1	b0
0 (fixed)															(1)

(1) 0: Not performed, 1: Completed

Remote buffer memory address

Name	Address
Module operation information initialization completed	1005H

Operation of the module operation information initialization

When initialization of the module operation information is completed, Module operation information initialization completed (address: 1005H) is turned to Completed (1).

For the timing of turning the bit to Not performed (0) → Completed (1) → Not performed (0), refer to the following.

☞ Page 163 Module operation information initialization command

Default value

The default value is Not performed (0).

Number of ON times integration value clear command

This remote buffer memory area is used to clear Number of ON times integration value Y□ (address: 0610H to 062FH).

b15	b14	b13	b12	b11	b10	b9	b8	b7*1	b6*1	b5*1	b4*1	b3*1	b2*1	b1*1	b0*1
YF	YE	YD	YC	YB	YA	Y9	Y8	Y7	Y6	Y5	Y4	Y3	Y2	Y1	Y0

0: Not commanded

1: Commanded

*1 The use of these bits is prohibited for the NZ2GF12A42-16DT and NZ2GF12A42-16DTE.

Remote buffer memory address

Name	Address
Number of ON times integration value clear command	1100H

Operation of the number of ON times integration value clear

When a specified bit of Number of ON times integration value clear command (address: 1100H) is set to Commanded (1), the number of ON times integration value in the specified bit is cleared.

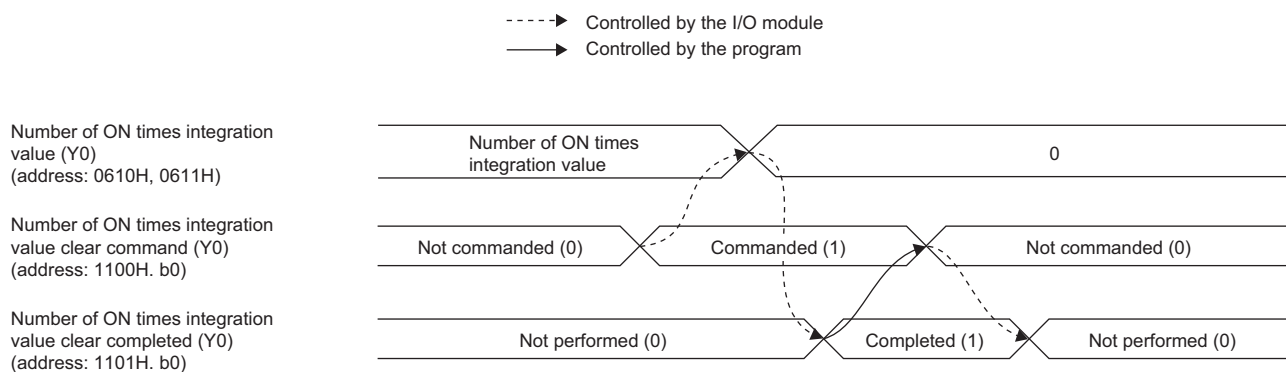

Clearing by turning on Number of ON times integration value clear command

The number of ON times integration value is cleared only once when the specified bit of Number of ON times integration value clear command (address: 1100H) is set to Commanded (1). The number of ON times integration function is executed while the specified bit remains set to Commanded (1).

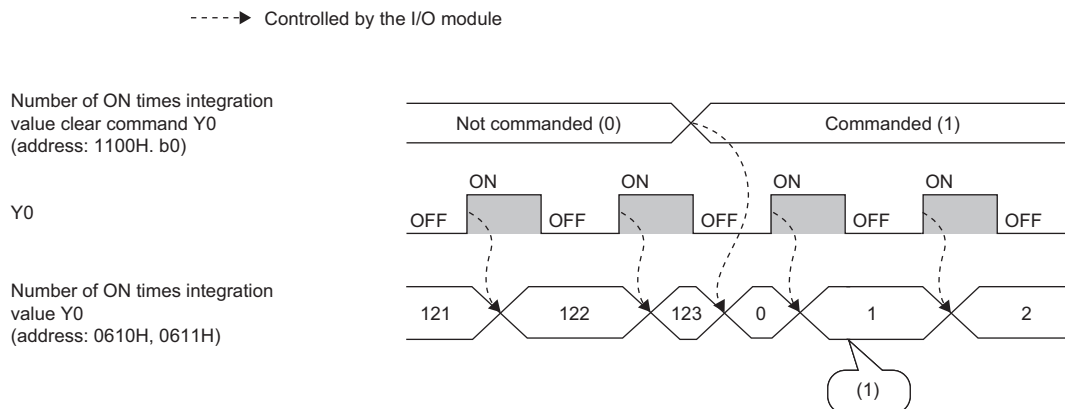

(1) The number of ON times is integrated even while Number of ON times integration value clear command (address: 1100H.b0) remains set to Commanded (1).

Default value

The default value is Not commanded (0).

Number of ON times integration value clear completed

This remote buffer memory area shows whether Number of ON times integration value Y□ (address: 0610H to 062FH) has been cleared or not.

b15	b14	b13	b12	b11	b10	b9	b8	b7*1	b6*1	b5*1	b4*1	b3*1	b2*1	b1*1	b0*1
YF	YE	YD	YC	YB	YA	Y9	Y8	Y7	Y6	Y5	Y4	Y3	Y2	Y1	Y0

0: Not performed

1: Completed

*1 The use of these bits is prohibited for the NZ2GF12A42-16DT and NZ2GF12A42-16DTE.

Remote buffer memory address

Name	Address
Number of ON times integration value clear completed	1101H

Operation of the module operation information initialization

When clearing the number of ON times integration value is completed, the specified bit of Number of ON times integration value clear completed (address: 1101H) is turned to Completed (1).

For the timing of turning the bit to Not performed (0) → Completed (1) → Not performed (0), refer to the following.

 Page 164 Number of ON times integration value clear command

Default value

The default value is Not performed (0).

Appendix 4 EMC and Low Voltage Directives

Compliance to the EMC Directive, which is one of the EU Directives, has been a legal obligation for the products sold in European countries since 1996 as well as the Low Voltage Directive since 1997.

Manufacturers who recognize their products are compliant to the EMC and Low Voltage Directives are required to attach a "CE mark" on their products.

Sales representative in EU member states

Authorized representative in EU member states is shown below.

Name: MITSUBISHI ELECTRIC EUROPE B.V.

Address: Mitsubishi-Electric-Platz 1, 40882 Ratingen, Germany

Measures to comply with the EMC Directive

The EMC Directive specifies that "products placed on the market must be so constructed that they do not cause excessive electromagnetic interference (emissions) and are not unduly affected by electromagnetic interference (immunity)".

This section summarizes the precautions on compliance with the EMC Directive of the machinery constructed with the module.

These precautions are based on the requirements and the standards of the regulation, however, it does not guarantee that the entire machinery constructed according to the descriptions will comply with abovementioned directives.

The method and judgment for complying with the EMC Directive must be determined by the person who constructs the entire machinery.

EMC Directive related standards

■ Emission requirements

Specifications	Test item	Test details	Standard value
EN61131-2: 2007	CISPR16-2-3 Radiated emission	Radio waves from the product are measured.	<ul style="list-style-type: none"> • 30M-230MHz QP: 40dBμV/m (10m in measurement range)^{*1} • 230M-1000MHz QP: 47dBμV/m (10m in measurement range)
	CISPR16-2-1, CISPR16-1-2 Conducted emission	Noise from the product to the power line is measured.	<ul style="list-style-type: none"> • 150k-500kHz QP: 79dB, Mean: 66dB^{*1} • 500k-30MHz QP: 73dB, Mean: 60dB

*1 QP: Quasi-peak value, Mean: Average value

■ Immunity requirements

Specifications	Test item	Test details	Standard value
EN61131-2: 2007	EN61000-4-2 Electrostatic discharge immunity	Immunity test in which electrostatic is applied to the cabinet of the equipment.	<ul style="list-style-type: none"> • 8kV Air discharge • 4kV Contact discharge
	EN61000-4-3 Radiated, radio-frequency, electromagnetic field immunity	Immunity test in which electric fields are irradiated to the product.	<ul style="list-style-type: none"> • 80% AM modulation@1kHz • 80M-1000MHz: 10V/m • 1.4G-2.0GHz: 3V/m • 2.0G-2.7GHz: 1V/m
	EN61000-4-4 Electrical fast transient/ burst immunity	Immunity test in which burst noise is applied to the power line and signal line.	<ul style="list-style-type: none"> • AC/DC main power, I/O power, AC I/O (unshielded): 2kV • DC I/O, analog, communication: 1kV
	EN61000-4-5 Surge immunity	Immunity test in which lightning surge is applied to the power line and signal line.	<ul style="list-style-type: none"> • AC power line, AC I/O power, AC I/O (unshielded): 2kV CM, 1kV DM • DC power line, DC I/O power: 0.5kV CM, DM • DC I/O, AC I/O (shielded), analog^{*1}, communication: 1kV CM
	EN61000-4-6 Immunity to conducted disturbances, induced by radio-frequency fields	Immunity test in which high frequency noise is applied to the power line and signal line	0.15M-80MHz, 80% AM modulation @1kHz, 10Vrms
	EN61000-4-8 Power-frequency magnetic field immunity	Immunity test in which the product is installed in inductive magnetic field	50Hz/60Hz, 30A/m
	EN61000-4-11 Voltage dips and interruption immunity	Immunity test in which power supply voltage is momentarily interrupted	<ul style="list-style-type: none"> • Apply at 0%, 0.5 cycles and zero-cross point • 0%, 250/300 cycles (50/60Hz) • 40%, 10/12 cycles (50/60Hz) • 70%, 25/30 cycles (50/60Hz)

*1 The accuracy of an analog-digital converter module may temporarily vary within $\pm 10\%$.

External power supply

- Use a CE-marked product for an external power supply and always ground the FG metal fitting. (External power supply used for the tests conducted by Mitsubishi: TDK-Lambda DLP-120-24-1, IDEC PS5R-SF24, PS5R-F24)
- Use a power cable of 10m or shorter when connecting it to the module power supply terminal.
- Use a power cable of 30m or shorter when connecting it to the load power supply for output part.

A

Others

■ Ferrite core

A ferrite core has the effect of reducing radiated noise in the 30MHz to 100MHz band.

It is recommended to attach ferrite cores if shielded cables coming out of the control panel do not provide sufficient shielding effects.

Note that the ferrite cores must be attached at the position closest to the cable hole inside the control panel. If attached at an improper position, the ferrite core will not produce any effect.

For the FG metal fitting that is connected to the load power supply of an I/O module and CC-Link IE Field Network cables, attach a ferrite core 4cm away from the module.

(Ferrite core used for the tests conducted by Mitsubishi: NEC TOKIN ESD-SR-250, TDK ZCAT3035-1330)

Ex.

Example

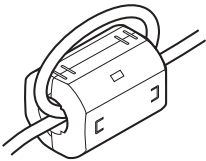

■ Noise filter (power supply line filter)

A noise filter is a component which has an effect on conducted noise. Attaching the filter can suppress more noise. (The noise filter has the effect of reducing conducted noise of 10MHz or less.)

Connect a noise filter to the load power supply of an I/O module. Use a noise filter with the damping characteristics equivalent to those of MA1206 (manufactured by TDK-Lambda Corporation). Note that a noise filter is not required if the module is used in Zone A defined in EN61131-2.

The precautions for attaching a noise filter are described below.

- Do not bundle the cables on the input side and output side of the noise filter. If bundled, the output side noise will be induced into the input side cables from which the noise was filtered.

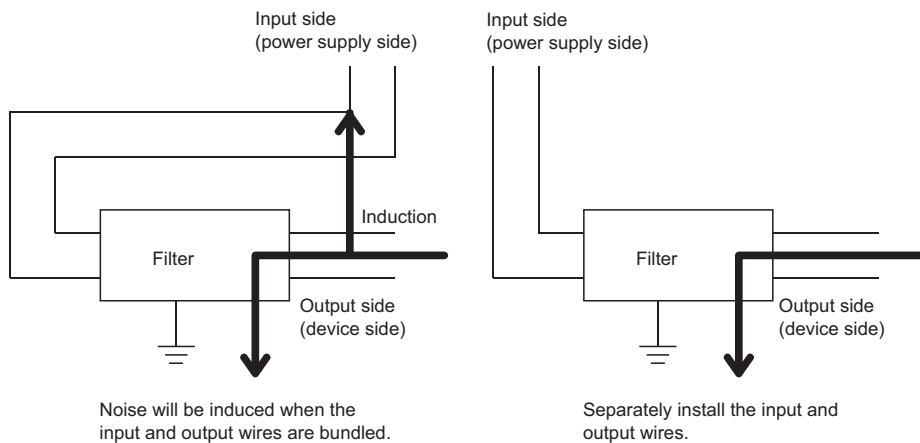

- Ground the noise filter grounding terminal to the control panel with the shortest cable possible (approx. 10cm).

Requirements to compliance with the Low Voltage Directive

The module operates at the rated voltage of 24VDC.

The Low Voltage Directive is not applied to the modules that operate at the rated voltage of less than 50VAC and 75VDC.

Appendix 6 External Dimensions

The following figures show the external dimensions of the I/O module.

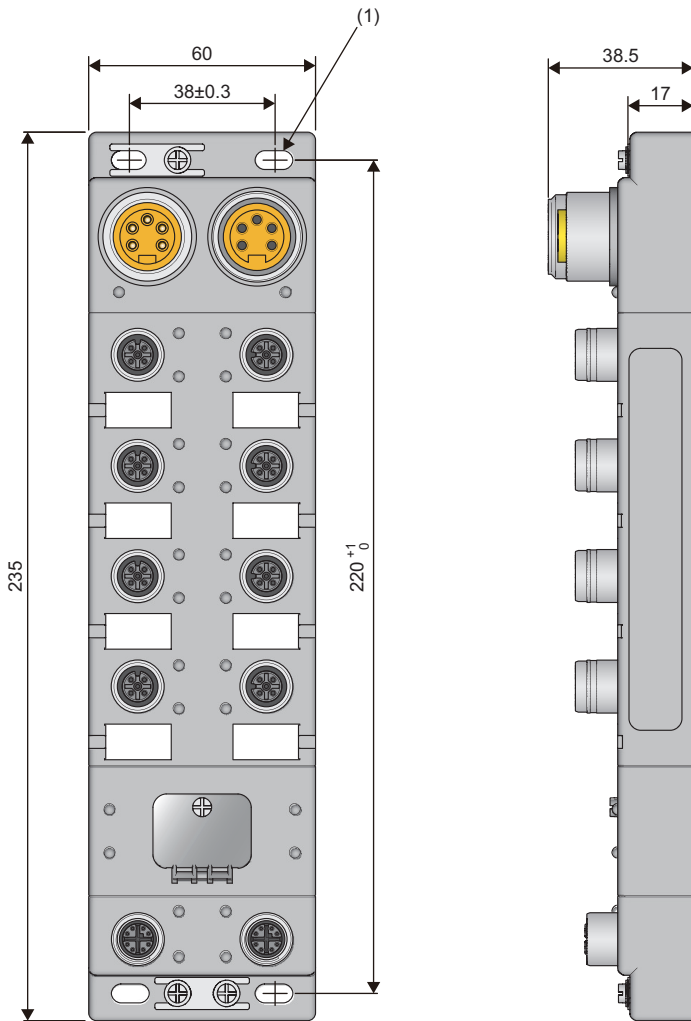

(Unit: mm)

(1) 4-5 × 10 slotted hole (M4 mounting screw)

MEMO

INDEX

A

Applicable systems	62
Applicable systems (Applicable master station) . .	62
Attaching waterproof caps	71
Available software	62

C

CC-Link IE Field Network diagnostic function . . .	100
Checking for the error codes and the warning codes	121
Checking for the error codes and the warning codes (Checking by Error code (RWr1))	123
Checking for the error codes and the warning codes (Checking by executing a command of the slave station)	121
Checking the LEDs	128
Cyclic data update watch function	88
Cyclic data update watch time setting	155

D

D LINK LED	18
Details of remote I/O signals	143

E

ERR. LED	17
Error clear request flag (RWw0.b10)	152
Error code	148
Error code details (address: 0A06H to 0A0FH) . .	160
Error code list	124
Error history area (address: 0A00H to 0FFFH) . .	57
Error history clear command	161
Error history clear completed	161
Error history data	159
Error notification function	81
Error status flag (RWr0.b10)	147
Ethernet cable	62
External dimensions	170
External input signal	143
External output signal	143

F

Fast logic enable status	157
Fast logic function	95
Fast logic setting	157
Fixing the I/O module	68
Function list	44
Function selection setting flag	152
Function selection status flag	149

G

General specifications	19
----------------------------------	----

H

How to check serial number and function version .	169
---	-----

I

I/O combined module	13
I/O combined module specifications	34
I/O LED	17
I/O module	13
I/O module specifications	20
Initial operation setting	155
Initial operation setting function	98
Initial processing completion flag (RWw0.b8) . . .	152
Initial processing request flag (RWr0.b8)	144
Input module	13
Input module specifications	20
Input OFF delay function	84
Input OFF delay setting	156
Input response time setting	154
Input response time setting function	86
Input X port status	149
Installation and wiring	64
Installation direction	67
Installation environment	66
Installation environment and installation position .	66
Installation position	67

L

L ER LED	18
L PW LED	17
LINK LED	18
List of remote buffer memory	50
List of remote I/O signals	46
List of remote register	48

M

Maintenance and inspection	119
Measures to comply with the EMC Directive . . .	166
Measures to comply with the EMC Directive (EMC Directive related standards)	167
Measures to comply with the EMC Directive (External power supply)	167
Measures to comply with the EMC Directive (Others)	168
MODE LED	17
Module control data area (address: 1000H to 14FFH)	58
Module operation area	152
Module operation information initialization command	163
Module operation information initialization completed	163
Module operation information initialization	163
Module status area	144
Monitoring area (address: 0500H to 09FFH)	55

N

Number of ON times integration function	89
Number of ON times integration function enable	156
Number of ON times integration value	158
Number of ON times integration value clear command	164
Number of ON times integration value clear completed	165

O

Operation condition setting completion flag (RWr0.b9)	146
Operation condition setting request flag (RWw0.b9)	152
Output HOLD/CLEAR setting	154
Output HOLD/CLEAR setting function	87
Output module	13
Output module specifications	26
Output ON/OFF information hold function	91
Output Y channel status	149
Output Y current value	150
Output Y OFF information	151
Output Y OFF information clear request	153
Output Y ON information	150
Output Y ON information clear request	152
Overheat protection function	100
Overload protection function	100

P

Parameter area (address: 0000H to 04FFH)	51
Parameter area initialization command	162
Parameter area initialization completed	162
Parameter setting	72
Parameter setting (changing the network configuration)	77
Parameter setting (changing the parameter without changing the network configuration)	79
Part names	16
Power supply monitor request flag (RWw3.b0)	152
Power supply monitor state flag (RWr3.b0)	149
Power supply monitoring function	92
Precautions for programming	103
Procedure for programming	104
Procedures before operation	60
Product lineup	13
Program example for checking the fast logic enable or disable status	117
Program example for checking the number of ON times	111
Program example for clearing the number of ON times	111
Program example for the fast logic function	114
Programming	103
Protection function	100
PW LED	17

R

Remote READY (RWr0.b11)	148
Replacing the module	60
Requirements to compliance with the Low Voltage Directive	168
RUN LED	17

S

Setting switch	64
Short-circuit detection function	93
Specifications	19
Station number setting with the station number setting switch	64
System configuration	62

T

Terms	12
Transition wiring of the power supply	68
Troubleshooting	121
Troubleshooting for each phenomenon	132
Troubleshooting for input circuit	134
Troubleshooting for output circuit	137

U

Unit test	131
---------------------	-----

W

Warning code	148
Warning status flag (RWr0.b12)	148
Wiring of Ethernet cable	69
Wiring the power supply	68

REVISIONS

*The manual number is given on the bottom left of the back cover.

Print date	*Manual number	Revision
February 2017	SH(NA)-081637ENG-A	First edition
July 2017	SH(NA)-081637ENG-B	■Added or modified part Chapter 2

Japanese manual number: SH-081636-B

This manual confers no industrial property rights or any rights of any other kind, nor does it confer any patent licenses. Mitsubishi Electric Corporation cannot be held responsible for any problems involving industrial property rights which may occur as a result of using the contents noted in this manual.

© 2017 MITSUBISHI ELECTRIC CORPORATION

WARRANTY

Please confirm the following product warranty details before using this product.

1. Gratis Warranty Term and Gratis Warranty Range

If any faults or defects (hereinafter "Failure") found to be the responsibility of Mitsubishi occurs during use of the product within the gratis warranty term, the product shall be replaced at no cost via the sales representative.

However, if on-site service are required at domestic or overseas location, expenses to send an engineer will be solely at the customer's discretion. Mitsubishi shall not be held responsible for any re-commissioning, maintenance, or testing on-site that involves replacement of the failed module.

[Gratis Warranty Term]

The gratis warranty term of the product shall be for one year after the date of purchase or delivery to a designated place. Note that after manufacture and shipment from Mitsubishi, the maximum distribution period shall be six (6) months, and the longest gratis warranty term after manufacturing shall be eighteen (18) months. The gratis warranty term of replacement shall not exceed the gratis warranty term before product exchange.

[Gratis Warranty Range]

- (1) The range shall be limited to normal use within the usage state, usage methods and usage environment, etc., which follow the conditions and precautions, etc., given in the instruction manual, user's manual and caution labels on the product.
- (2) Even within the gratis warranty term, replacement shall be charged for in the following cases.
 1. Failure occurring from inappropriate storage or handling, carelessness or negligence by the user. Failure caused by the user's hardware or software design.
 2. Failure caused by unapproved modifications, etc., to the product by the user.
 3. When the Mitsubishi product is assembled into a user's device, Failure that could have been avoided if functions or structures, judged as necessary in the legal safety measures the user's device is subject to or as necessary by industry standards, had been provided.
 4. Failure that could have been avoided if consumable parts (battery, backlight, fuse, etc.) designated in the instruction manual had been correctly serviced or replaced.
 5. Failure caused by external irresistible forces such as fires or abnormal voltages, and Failure caused by force majeure such as earthquakes, lightning, wind and water damage.
 6. Failure caused by reasons unpredictable by scientific technology standards at time of shipment from Mitsubishi.
 7. Any other failure found not to be the responsibility of Mitsubishi or that admitted not to be so by the user.

2. Repair and Analysis

Please note that repairs and failure analysis are refused due to the structure of this product.

3. Discontinuation of production

- (1) Discontinuation of production shall be notified with Mitsubishi Technical Bulletins, etc.
- (2) Product supply (including repair parts) is not available after production is discontinued.

4. Overseas service

Overseas, please contact Mitsubishi's local overseas FA Center.

5. Exclusion of loss in opportunity and secondary loss from warranty liability

Regardless of the gratis warranty term, Mitsubishi shall not be liable for compensation to:

- (1) Damages caused by any cause found not to be the responsibility of Mitsubishi.
- (2) Loss in opportunity, lost profits incurred to the user by Failures of Mitsubishi products.
- (3) Special damages and secondary damages whether foreseeable or not, compensation for accidents, and compensation for damages to products other than Mitsubishi products.
- (4) Replacement by the user, maintenance of on-site equipment, start-up test run and other tasks.

6. Changes in product specifications

The specifications given in the catalogs, manuals or technical documents are subject to change without prior notice.

TRADEMARKS

Ethernet is a registered trademark of Fuji Xerox Co., Ltd. in Japan.

The company names, system names and product names mentioned in this manual are either registered trademarks or trademarks of their respective companies.

In some cases, trademark symbols such as [™] or [®] are not specified in this manual.

molex Molex, LLC www.molex.com

SH(NA)-081637ENG-B(1707)MEE

MODEL: CCIEF-WD-IO-U-E

MODEL CODE: 13JX54

MITSUBISHI ELECTRIC CORPORATION

HEAD OFFICE : TOKYO BUILDING, 2-7-3 MARUNOUCHI, CHIYODA-KU, TOKYO 100-8310, JAPAN
NAGOYA WORKS : 1-14, YADA-MINAMI 5-CHOME, HIGASHI-KU, NAGOYA, JAPAN

When exported from Japan, this manual does not require application to the
Ministry of Economy, Trade and Industry for service transaction permission.

Specifications subject to change without notice.