



## Main

Commercial Status	Commercialised
Range of product	Harmony XB5S
Product or component type	Biometric switch
Product specific application	Industrial machines Materials handling
Device short name	XB5S
Bezel material	Plastic
Mounting diameter	22 mm
Output type	PNP
Sale per indivisible quantity	1
IP degree of protection	IP65 front face conforming to EN/IEC 60529 IP20 rear face conforming to EN/IEC 60529
Type of operator	Momentary
Operator profile	Fingerprint reader
Connections - terminals	1 pre-wired cable, clamping capacity: 3 x 0.34 mm <sup>2</sup>
Memory usage	200 users with up to 2 fingerprints per user

## Complementary

Enclosure material	Polyamide PA66
Cable insulation material	PvR
Operating position	Flat surface installation Horizontal position Vertical surface installation
Function of module	Monostable
Product weight	0.17 kg
Marking	CE
Local signalling	1 LED red, function: reset 1 LED red, function: error 1 LED orange, function: operator's registration mode 1 LED orange, function: administrator's registration mode 1 LED green, function: output state indicator
Short circuit protection	250 mA by gG external fuse
[Us] rated supply voltage	24 V DC
Electrical connection	Free wire ends with 3 wires of 2 m
Supply voltage limits	20...30 V DC
Protection type	Overload protection Reverse polarity Short-circuit
Maximum switching current	<= 200 mA
[Ures] residual voltage	<= 1 V, closed state
Current consumption	<= 50 mA no-load
Delay first up	< 2 s
Delay recovery	< 1 s
Delay response	< 1 s

## Environment

Ambient air temperature for storage	-25...70 °C
Ambient air temperature for operation	-5...50 °C
NEMA degree of protection	NEMA 12
Standards	IEC 61000-6-2 IEC 61000-6-4
Product certifications	CSA UL
Vibration resistance	1 gn (f = 9...500 Hz) conforming to IEC 60068-2-6 +/- 3 mm (f = 5...9 Hz) conforming to IEC 60068-2-6
Shock resistance	50 gn for 11 ms conforming to IEC 60068-2-27

## Offer Sustainability

Sustainable offer status	Green Premium product
RoHS	Compliant - since 0910 - <a href="#">Schneider Electric declaration of conformity</a>
REACH	Reference contains SVHC above the threshold - <a href="#">go to CaP for more details</a>
Product environmental profile	Available
Product end of life instructions	Need no specific recycling operations

Dimensions of Biometric Switches

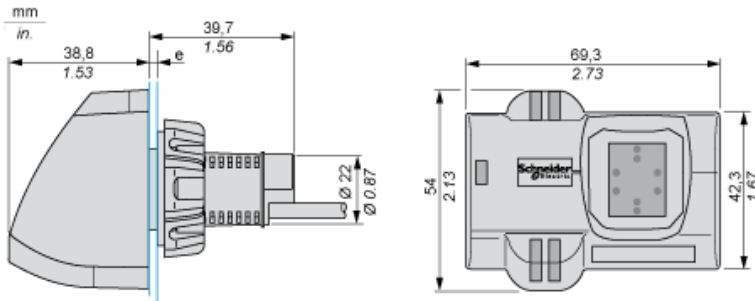

e: 1 to 6 mm / 0.04 to 0.24 in.

---

Cable with PNP Output

---

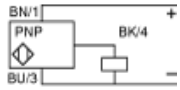

BU: Blue  
BN: Brown  
BK: Black