

XZBWR2STT24

programmable receiver - 4 PNP - 200 mA - 24 V DC
- 2 pusbuttons - 6 LEDs



Main

Product or component type	Programmable receiver
Device application	Interface to PLC
Product compatibility	Radio transmitter XZBWE

Complementary

Function of module	Receiver unit for remote sensor
Number of transceivers	> 0...2 by ZigBee
Nominal output current	0.8 A at 24 V DC
Output type	Transistor PNP
Output contacts	4 PNP
Time delay range	0.5 s (- 15...15 %)
Starting time	<= 400 ms
Maximum switching current	200 mA DC
Minimum switching current	10 mA
[Us] rated supply voltage	24 V DC (- 15...20 %)
Voltage drop	<= 2 V (nominal output current <= 200 mA)
Communication port protocol	Zigbee green power at 2.4 GHz
Maximum sensing distance	100 m in free field 25 m in a metal enclosure
Response time	< 30 ms after sensor change
Number of channels	<= 2 per receiver
Utilisation category	DC-13 conforming to EN/IEC 60947-5-1
Power consumption in W	26 W DC
Breaking capacity	4.8 W per output
Short circuit protection	1 A by fast blow fuse
Operating position	Any position without derating
Electrical connection	1 conductor cable 0.14...2.5 mm ² AWG 26...AWG 14 solid without cable end conforming to IEC 60947-1 2 conductors cable 0.14...1.5 mm ² AWG 26...AWG 16 solid without cable end conforming to IEC 60947-1 1 conductor cable 0.14...4 mm ² AWG 26...AWG 12 flexible with cable end conforming to IEC 60947-1 2 conductors cable 0.14...1.5 mm ² AWG 26...AWG 16 flexible with cable end conforming to IEC 60947-1
Tightening torque	0.5...1 N.m conforming to EN/IEC 60947-1
Housing material	Self-extinguishing plastic
Status LED	Power ON: 1 LED green Reception signal: 1 LED green and yellow Output active: 4 LEDs green
Mounting support	35 mm symmetrical DIN rail conforming to EN/IEC 60715 Mounting plate
Rated short-duration power frequency withstand voltage	1 kV at 50 Hz conforming to EN/IEC 60947-5-1
[Uimp] rated impulse withstand voltage	0.8 kV
Width	36 mm
Height	108 mm

The information provided in this documentation contains general descriptions and/or technical characteristics of the performance of the products contained herein. This documentation is not intended as a substitute for and is not to be used for determining suitability or reliability of these products for specific user applications. It is the duty of any such user or integrator to perform the appropriate and complete risk analysis, evaluation and testing of the products with respect to the relevant specific application or use thereof. Neither Schneider Electric Industries SAS nor any of its affiliates or subsidiaries shall be responsible or liable for misuse of the information contained herein.

Depth	75 mm
Product weight	0.13 kg
Marking	CE

Environment

surge withstand	Differential mode: 0.5 kV conforming to IEC 61000-4-5 Common mode: 1 kV conforming to IEC 61000-4-5
standards	EN/IEC 60947-1 EN/IEC 60947-5-1
ambient air temperature for storage	-40...70 °C
relative humidity	90 % without condensation (-20...55 °C) conforming to ETSI EN 300 328
vibration resistance	+/- 7.5 mm (5...14 Hz) conforming to IEC 60068-2-6 2 gn (8...150 Hz) conforming to IEC 60068-2-6
shock resistance	10 gn with 6000 shocks during 16 ms conforming to IEC 60068-2-27
IP degree of protection	Casing: IP20 conforming to IEC 60529 Terminals: IP20 conforming to IEC 60529
pollution degree	2 conforming to IEC 60664-1
overvoltage category	III conforming to IEC 60664-1
insulation resistance	> 500 MOhm at 500 V DC conforming to NF C 20-030
[Uij] rated insulation voltage	< 60 V conforming to IEC 60664-1
electromagnetic compatibility	Immunity for industrial environments conforming to EN/IEC 61000-6-2 Conducted and radiated emissions class B conforming to CISPR 22 Electrostatic discharge immunity test 8 kV in free air (in insulating parts) conforming to IEC 61000-4-2 Electrostatic discharge immunity test 6 kV on contact (on metal parts) conforming to IEC 61000-4-2 Susceptibility to electromagnetic fields 10 V/m, 80 MHz...1 GHz at 3 m conforming to IEC 61000-4-3 Susceptibility to electromagnetic fields 3 V/m, 1.4 MHz...2 GHz at 3 m conforming to IEC 61000-4-3 Electrical fast transient/burst immunity test 2 kV power supply wires conforming to IEC 61000-4-4 Conducted RF disturbances 10 V conforming to IEC 61000-4-6 Radiated emission conforming to ETSI EN 301 489-17 Conducted emission conforming to ETSI EN 301 489-17 Radiated emission conforming to ETSI EN 300 328 Electrical fast transient/burst immunity test 1 kV PNP output wires conforming to IEC 61000-4-4 1.2/50 µs shock waves immunity test 0.5 kV differential mode conforming to IEC 61000-4-5 1.2/50 µs shock waves immunity test 1 kV common mode conforming to IEC 61000-4-5 Immunity to microbreaks and voltage drops 7 ms conforming to IEC 61000-4-11

Offer Sustainability

Sustainable offer status	Not Green Premium product
RoHS (date code: YYWW)	Compliant - since 1510 - Schneider Electric declaration of conformity
REACH	Reference not containing SVHC above the threshold

Receiver Dimensions

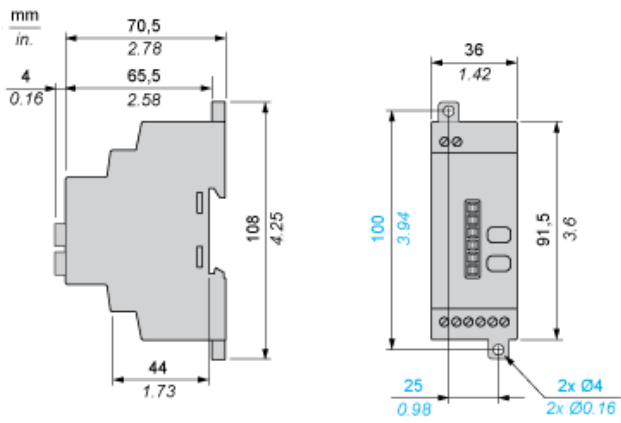

Receiver Wiring Diagram

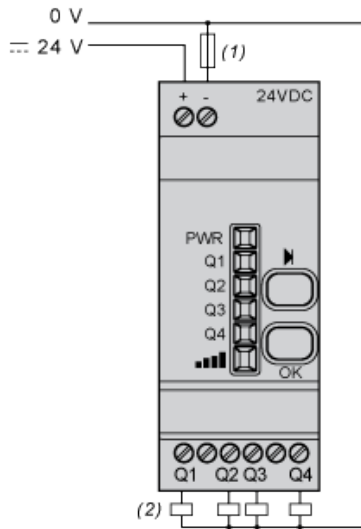

- (1) 400 mA fast-blow fuse
- (2) I_{max} = 200 mA

Receiver Mounting

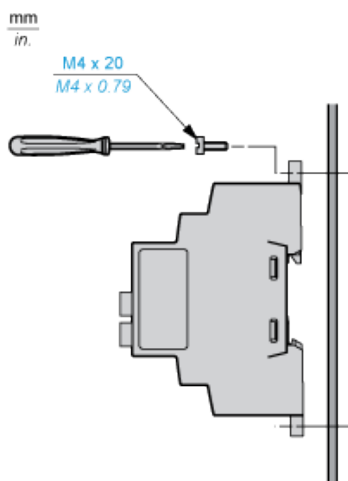

Receiver Mounting

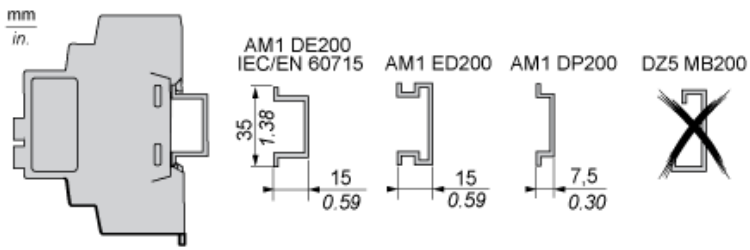

Receiver Mounting

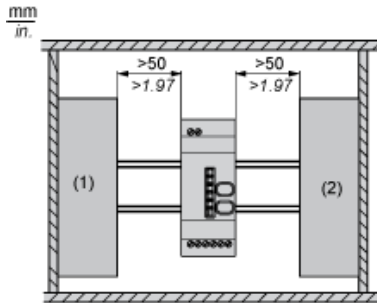

- (1) Drive
- (2) Power Supply or PLC

Unobstructed Mounting

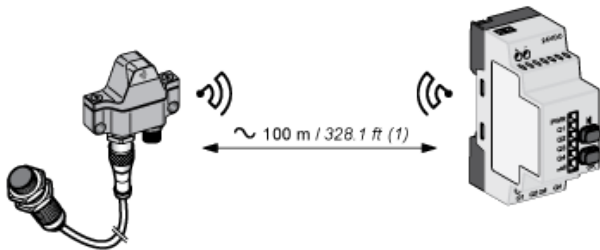

- (1) Typical values that may be modified by the application environment.

Mounting in a Metal Cabinet

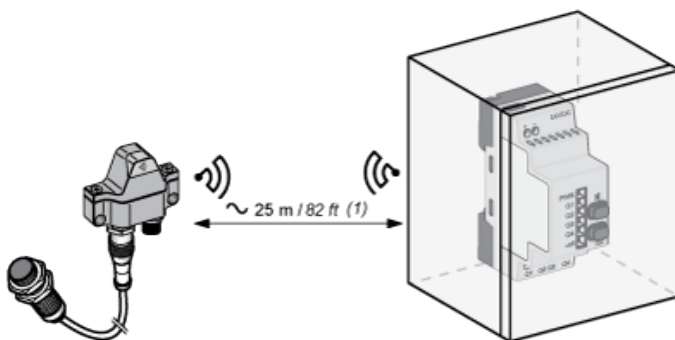

- (1) Typical values that may be modified by the application environment.