

### Main

Commercial Status	Commercialised
Range of product	Harmony XAC
Product or component type	Pendant control station
Control station name	XACA pistol grip
Control station type	Double insulated
Enclosure material	Polypropylene
Control type	Intuitive
Electrical circuit type	Control circuit
Enclosure type	Complete ready for use
Control station application	Control of single speed hoist motor
Control station composition	2 booted pushbuttons
Control button type	Second pushbutton 1 NC + 1 NO lower, slow First pushbutton 1 NC + 1 NO raise, slow
Contact block name	ZB2BE102 + ZB2BE101 for each direction
Mechanical interlocking	With mechanical interlocking

### Complementary

Control station colour	Yellow
Connections - terminals	Screw clamp terminals, connection capacity: 2 x 1.5 mm <sup>2</sup> with or without cable end Screw clamp terminals, connection capacity: 1 x 2.5 mm <sup>2</sup> with or without cable end
Mechanical durability	1000000 cycles
Cable entry	Rubber sleeve with stepped entry, cable outer diameter: 7...15 mm
Contact code designation	Q600 DC-13, U <sub>e</sub> = 600 V, I <sub>e</sub> = 0.1 A conforming to IEC 60947-5-1 appendix A Q600 DC-13, U <sub>e</sub> = 250 V, I <sub>e</sub> = 0.27 A conforming to IEC 60947-5-1 appendix A A600 AC-15, U <sub>e</sub> = 600 V, I <sub>e</sub> = 1.2 A conforming to IEC 60947-5-1 appendix A A600 AC-15, U <sub>e</sub> = 240 V, I <sub>e</sub> = 3 A conforming to IEC 60947-5-1 appendix A
[I <sub>th</sub> ] conventional enclosed thermal current	10 A
[U <sub>i</sub> ] rated insulation voltage	600 V (degree of pollution: 3) conforming to IEC 60947-1
[U <sub>imp</sub> ] rated impulse withstand voltage	6 kV conforming to IEC 60947-1
Contacts operation	Slow-break
Resistance across terminals	<= 25 MOhm
Operating force	13...15 N
Short circuit protection	10 A fuse protection by cartridge fuse type gG
Rated operational power in W	65 W DC-13 for 1000000 cycles, operating rate = 60 cyc/mn at 24 V, load factor = 0.5 (inductive load) conforming to IEC 60947-5-1 appendix C 48 W DC-13 for 1000000 cycles, operating rate = 60 cyc/mn at 48 V, load factor = 0.5 (inductive load) conforming to IEC 60947-5-1 appendix C 40 W DC-13 for 1000000 cycles, operating rate = 60 cyc/mn at 120 V, load factor = 0.5 (inductive load) conforming to IEC 60947-5-1 appendix C
Terminals description ISO n°1	(11-12)NC (13-14)NO
Terminal identifier	(11-12)NC (13-14)NO
Product weight	0.32 kg

## Environment

Standards	CSA C22-2 No 14 EN/IEC 60204-32 EN/IEC 60947-5-1 EN/IEC 60947-5-5 EN/ISO 13850: 2006 UL 508
Product certifications	CSA UL
Protective treatment	TH
Ambient air temperature for operation	-25...70 °C
Ambient air temperature for storage	-40...70 °C
Vibration resistance	15 gn (f = 10...500 Hz) conforming to IEC 60068-2-6
Shock resistance	100 gn conforming to IEC 60068-2-27
Class of protection against electric shock	Class II conforming to IEC 61140
IP degree of protection	IP65 conforming to IEC 60529
IK degree of protection	IK08 conforming to EN 50102

## Contractual warranty

Period	18 months
--------	-----------

Dimensions

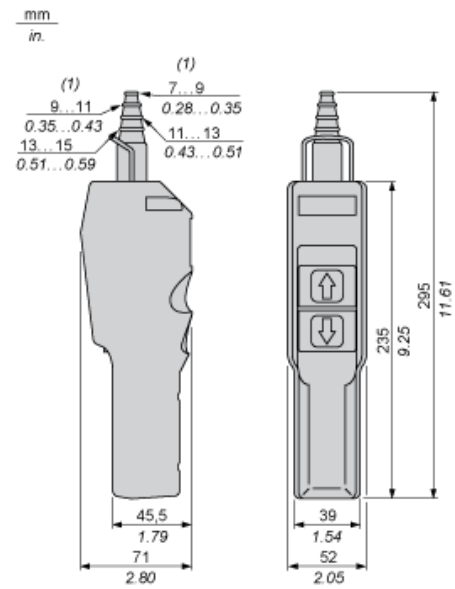

(1) Internal Ø

## Control of Single-Speed Reversing Motor

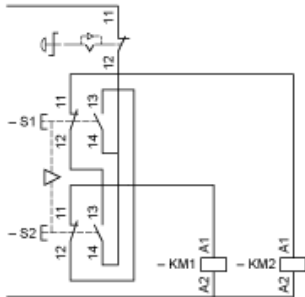

Rated Operational Power

AC Supply 50/60 Hz Inductive Circuit

Operating rate: 3600 operating cycles/hour. Load factor: 0.5.

Millions of operating cycles, AC-15 utilization category



I<sub>the</sub> Thermal current  
(A) Current

DC Supply

Operating rate: 3600 operating cycles/hour. Load factor: 0.5.

Power broken in W for 1 million operating cycles, DC-13 utilization category

Voltage	V	24	48	120
Inductive circuit	W	65	48	40