

XACA2114

pendant station XAC-A pistol grip - 2 booted push buttons 1 Emergency stop



Main

Range of product	Harmony XAC
Product or component type	Pendant control station
Control station name	XACA pistol grip
Control station type	Double insulated
Enclosure material	Polypropylene
Control type	Intuitive
Electrical circuit type	Control circuit
Enclosure type	Complete ready for use
Control station application	Control of single speed hoist motor
Control station composition	2 booted pushbuttons + 1 emergency stop
Control button type	Emergency stop pushbutton Ø 30 mm 1 NC, trigger action First pushbutton 1 NO raise, slow Second pushbutton 1 NO lower, slow
Contact block name	ZB2BE101 for each direction ZB2BE102 for emergency stop
Mechanical interlocking	With mechanical interlocking

Complementary

Control station colour	Yellow
Connections - terminals	Screw clamp terminals, connection capacity: 1 x 2.5 mm ² with or without cable end Screw clamp terminals, connection capacity: 2 x 1.5 mm ² with or without cable end
Mechanical durability	1000000 cycles
Cable entry	Rubber sleeve with stepped entry, cable outer diameter: 7...15 mm
Contact code designation	A600 AC-15, U _e = 240 V, I _e = 3 A conforming to IEC 60947-5-1 appendix A A600 AC-15, U _e = 600 V, I _e = 1.2 A conforming to IEC 60947-5-1 appendix A Q600 DC-13, U _e = 250 V, I _e = 0.27 A conforming to IEC 60947-5-1 appendix A Q600 DC-13, U _e = 600 V, I _e = 0.1 A conforming to IEC 60947-5-1 appendix A
[I _{the}] conventional enclosed thermal current	10 A
[U _i] rated insulation voltage	600 V (degree of pollution: 3) conforming to IEC 60947-1
[U _{imp}] rated impulse withstand voltage	6 kV conforming to IEC 60947-1
Contacts operation	Slow-break
Resistance across terminals	<= 25 MOhm
Operating force	13...15 N
Short circuit protection	10 A fuse protection by cartridge fuse type gG
Rated operational power in W	40 W DC-13 for 1000000 cycles, operating rate = 60 cyc/mn at 120 V, load factor = 0.5 (inductive load) conforming to IEC 60947-5-1 appendix C 48 W DC-13 for 1000000 cycles, operating rate = 60 cyc/mn at 48 V, load factor = 0.5 (inductive load) conforming to IEC 60947-5-1 appendix C 65 W DC-13 for 1000000 cycles, operating rate = 60 cyc/mn at 24 V, load factor = 0.5 (inductive load) conforming to IEC 60947-5-1 appendix C
Terminals description ISO n°1	(13-14)NO
Terminals description ISO n°2	(11-12)NC
Terminal identifier	(11-12)NC (13-14)NO
Product weight	0.31 kg

Environment

Standards	EN/IEC 60204-32 EN/IEC 60947-5-1 EN/IEC 60947-5-5 EN/ISO 13850: 2006
-----------	---

The information provided in this documentation contains general descriptions and/or technical characteristics of the products contained herein. This documentation is not intended as a substitute for and is not to be used for determining suitability or reliability of these products for specific user applications. It is the duty of any such user or integrator to perform the appropriate and complete risk analysis, evaluation and testing of the products with respect to the relevant specific application or use thereof. Neither Schneider Electric Industries SAS nor any of its affiliates or subsidiaries shall be responsible or liable for misuse of the information contained herein.

Product certifications	CSA UL
Protective treatment	TH
Ambient air temperature for operation	-25...70 °C
Ambient air temperature for storage	-40...70 °C
Vibration resistance	15 gn (f = 10...500 Hz) conforming to IEC 60068-2-6
Shock resistance	100 gn conforming to IEC 60068-2-27
Class of protection against electric shock	Class II conforming to IEC 61140
IP degree of protection	IP65 conforming to IEC 60529
IK degree of protection	IK08 conforming to EN 50102

Contractual warranty

Period	18 months
--------	-----------

Dimensions

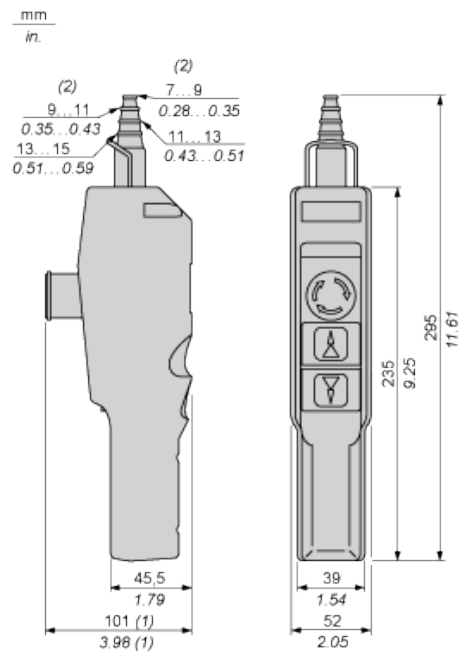

- (1) With trigger action latching \varnothing 30 mm / 1.18 in. Emergency stop.
- (2) Internal \varnothing

Control of Single-Speed Reversing Motor

