



PROGRAMMABLE CONTROLLERS
MELSEC iQ-F

MELSEC iQ-F FX5-4DA-ADP

Hardware Manual



Manual Number	JY997D60301
Revision	C
Date	April 2015

This manual describes the part names, dimensions, installation, and specifications of the product. Before use, read this manual and manuals of relevant products fully to acquire proficiency in handling and operating the product. Make sure to learn all the product information, safety information, and precautions.

And, store this manual in a safe place so that you can take it out and read it whenever necessary. Always forward it to the end user.

Registration:

The company name and the product name to be described in this manual are the registered trademarks or trademarks of each company.

Effective April 2015

Specifications are subject to change without notice.

© 2015 Mitsubishi Electric Corporation

Safety Precaution (Read these precautions before use.)

This manual classifies the safety precautions into two categories:

WARNING and **CAUTION**

WARNING	Indicates that incorrect handling may cause hazardous conditions, resulting in death or severe injury.
CAUTION	Indicates that incorrect handling may cause hazardous conditions, resulting in minor or moderate injury or property damage.

Depending on the circumstances, procedures indicated by **CAUTION** may also cause severe injury.

It is important to follow all precautions for personal safety.

Associated Manuals

Manual name	Manual No.	Description
MELSEC iQ-F FX5U User's Manual (Hardware)	JY997D55301	Explains FX5U PLC specification details for I/O, wiring, installation, and maintenance.
MELSEC iQ-F FX5UC User's Manual (Hardware)	JY997D61301	Explains FX5UC PLC specification details for I/O, wiring, installation, and maintenance.
MELSEC iQ-F FX5 User's Manual (Analog Control)	JY997D60501	Explains analog control.

How to obtain manuals

For the necessary product manuals or documents, consult with your local Mitsubishi Electric representative.

Applicable standards

FX5-4DA-ADP comply with the EC Directive (EMC Directive). Further information can be found in the following manual.

→ MELSEC iQ-F FX5U User's Manual (Hardware)

→ MELSEC iQ-F FX5UC User's Manual (Hardware)

Regarding the standards that relate to the CPU module, please refer to either the product catalog or consult with your nearest Mitsubishi product provider.

Attention

- This product is designed for use in industrial applications.

Note

- Authorized Representative in the European Community:
Mitsubishi Electric Europe B.V.
Gothaer Str. 8, 40880 Ratingen, Germany

Caution for EC Directive

• Installation in Enclosure
Programmable controllers are open-type devices that must be installed and used within conductive control cabinets. Please use the programmable controller while installed within a conductive shielded control cabinet. Installation within a control cabinet greatly affects the safety of the system and aids in shielding noise from the programmable controller.

• Control cabinet

- The control cabinet must be conductive.
- Ground the control cabinet with the thickest possible grounding cable.
- To ensure that there is electric contact between the control cabinet and its door, connect the cabinet and its doors with thick wires.
- In order to suppress the leakage of radio waves, the control cabinet structure must have minimal openings. Also, wrap the cable holes with a shielding cover or other shielding devices.
- The gap between the control cabinet and its door must be as small as possible by attaching EMI gaskets between them.

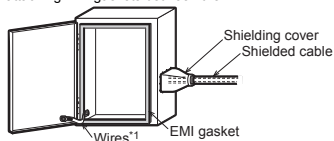

*1 These wires are used to improve the conductivity between the door and control cabinet.

• Cables

- Make sure to use shielded cables as cables pulled out of the control cabinet.
- Connect the shield such as shielded cables and shielding covers to the grounded control cabinet.

- It is possible that the accuracy temporarily fluctuates within ±10 %.
- Set the number of times of winding to "2 turns" within approximately 200 mm (7.87") from the connector of the power cable on the FX5-4DA-ADP side, and attach a ferrite core. (Ferrite core used in our test: E04SR401938 manufactured by SEIWA ELECTRIC MFG. CO., LTD.)
- The FX5-4DA-ADP requires that the cable used for power supply is 30 m (9'85") or less.

1. Outline

The FX5-4DA-ADP expansion adapter for analog output (hereinafter called 4DA-ADP) is an expansion adapter to add four analog output points.

1.1 Incorporated Items

Verify that the following product and items are included in the package:

Product	FX5-4DA-ADP analog output expansion adapter
Included Items	FX2NC-100MPCB power supply cable (1 m (3.33")) × 1 Hardware manual (This manual)

1.2 External Dimensions, Part Names, and Terminal Layout

Unit: mm (inches)

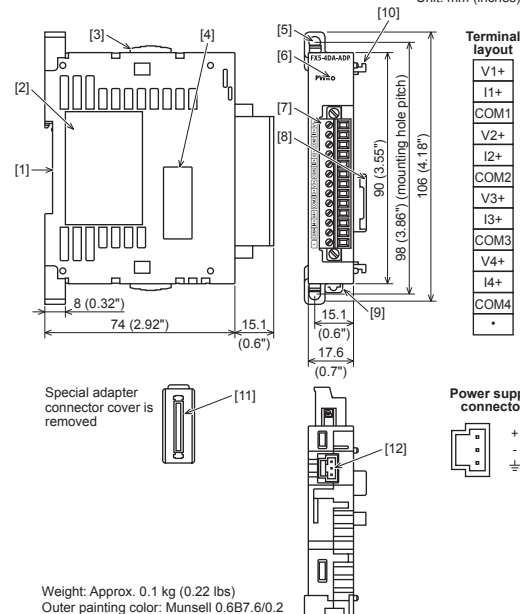

Terminal layout

V1+
I1+
COM1
V2+
I2+
COM2
V3+
I3+
COM3
V4+
I4+
COM4
•

- [1] DIN rail mounting groove (DIN rail: DIN46277, 35 mm (1.38") wide)
- [2] Name plate
- [3] Expansion adapter slide lock
- [4] Expansion adapter connector cover
- [5] Direct mounting hole: 2 holes of φ4.5 (0.18") (mounting screw: M4 screw)
- [6] PWR LED (green)
- [7] Terminal block (European type terminal block)
- [8] Expansion adapter connector
- [9] DIN rail mounting hook
- [10] Expansion adapter fixing hook
- [11] Expansion adapter connector
- [12] Power supply connector

2. Installation

INSTALLATION PRECAUTIONS **WARNING**

- Make sure to cut off all phases of the power supply externally before attempting installation or wiring work. Failure to do so may cause electric shock or damage to the product.
- Use the product within the generic environment specifications described in the FX5 User's Manual (Hardware). Never use the product in areas with excessive dust, oily smoke, conductive dusts, corrosive gas (salt air, Cl₂, H₂S, SO₂ or NO₂), flammable gas, vibration or impacts, or expose it to high temperature, condensation, or rain and wind. If the product is used in such conditions, electric shock, fire, malfunctions, deterioration or damage may occur.

INSTALLATION PRECAUTIONS **CAUTION**

- Do not touch the conductive parts of the product directly. Doing so may cause device failures or malfunctions.
- When drilling screw holes or wiring, make sure cutting or wire debris does not enter the ventilation slits. Failure to do so may cause fire, equipment failures or malfunctions.
- Install the product on a flat surface. If the mounting surface is rough, undue force will be applied to the PC board, thereby causing nonconformities.
- Install the product securely using a DIN rail or mounting screws.
- Connect the expansion board and expansion adapter securely to their designated connectors. Loose connections may cause malfunctions.

For the installation, refer to the following manual.

→ MELSEC iQ-F FX5U User's Manual (Hardware)

→ MELSEC iQ-F FX5UC User's Manual (Hardware)

3. Wiring

WIRING PRECAUTIONS **WARNING**

- Make sure to cut off all phases of the power supply externally before attempting installation or wiring work. Failure to do so may cause electric shock or damage to the product.
- Make sure to properly wire to the terminal block (European type) in accordance with the following precautions. Failure to do so may cause electric shock, equipment failures, a short-circuit, wire breakage, malfunctions, or damage to the product.
 - The disposal size of the cable end should follow the dimensions described in the manual.
 - Tightening torque should follow the specifications in the manual.
 - Twist the ends of stranded wires and make sure that there are no loose wires.
 - Do not solder-plate the electric wire ends.
 - Do not connect more than the specified number of wires or electric wires of unspecified size.
 - Affix the electric wires so that neither the terminal block nor the connected parts are directly stressed.

WIRING PRECAUTIONS **CAUTION**

- When drilling screw holes or wiring, make sure cutting or wire debris does not enter the ventilation slits. Failure to do so may cause fire, equipment failures or malfunctions.
- Make sure to observe the following precautions in order to prevent any damage to the machinery or accidents due to malfunction of the PLC caused by abnormal data written to the PLC due to the effects of noise:
 - Do not bundle the power line or analog input/output cable together with or lay them close to the main circuit, high-voltage line, load line or power line. As a guideline, lay the power line, control line and communication cables at least 100 mm (3.94") away from the main circuit, high-voltage line, load line or power line.
 - Ground the shield of the analog input/output cable at one point on the signal receiving side. However, do not use common grounding with heavy electrical systems.

3.1 Cable end treatment and tightening torque

3.1.1 European type terminal block

1) Suitable wiring

No. of wire per terminal	Wire size	
	Single wire, Strand wire	Ferrules with insulating sleeve
One wire	AWG22 to 20 (0.3 to 0.5 mm ²)	AWG22 to 20 (0.3 to 0.5 mm ²)
Two wires	AWG22 (0.3 mm ²)	-

2) Tightening torque

Tighten the terminal screws with 0.20 N•m. Do not tighten the screws outside the specified torque. Failure to do so may cause equipment failures or malfunctions.

- 3) Wire end treatment
Strip the coating of strand wire and twist the cable core before connecting it, or strip the coating of single wire before connecting it.
When using a wire ferrule with an insulating sleeve, choose a wire with proper cable sheath referring to the above outside dimensions, otherwise the wire cannot be inserted easily.

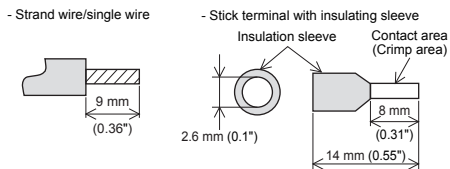

<Reference>

Manufacturer	Model	Caulking tool
Phoenix Contact GmbH & Co. KG	AI 0.5-8 WH	CRIMPFOX 6 CRIMPFOX 6T-F

- 4) Tool
For tightening the terminal, use a commercially available small screwdriver having a straight form that is not widened toward the end as shown right.

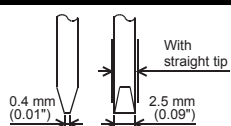

Note:
If the diameter of screwdriver grip is too small, tightening torque may not be achieved. To achieve the appropriate tightening torque shown in the table above, use the following screwdriver or appropriate replacement (grip diameter: approximately 25 mm (0.98 inch)).

Manufacturer	Model names
Phoenix Contact GmbH & Co. KG	SZS 0.4x2.5

- 5) Terminal block fixed screw tightening torque
Tighten the screws within the range of 0.2 to 0.3 N·m.
Do not tighten terminal screws exceeding with a torque outside the abovementioned range.
Failure to do so may cause equipment failures or malfunctions.

3.2 Power Supply Wiring

For the power supply wiring, refer to the following manual.
→ MELSEC IQ-F FX5 User's Manual (Analog Control)

3.3 Wiring of Analog Input

→ For the terminal configuration, refer to Section 1.2

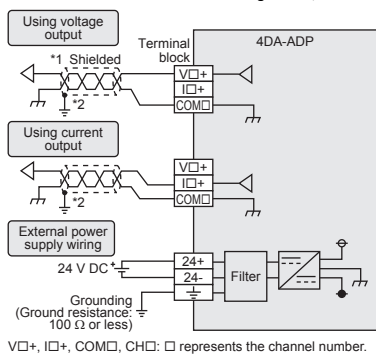

- *1 Use 2-core shielded twisted pair cable for the analog output lines, and separate the analog output lines from other power lines or inductive lines.

- *2 Ground the shielded wire at one point on the signal receiving side.

3.4 Grounding

Grounding should be performed as stated below.

- The grounding resistance should be 100 Ω or less.
- Independent grounding should be performed for best results.
When independent grounding is not performed, perform "shared grounding" of the following figure.

For the details, refer to the following manual.
→ MELSEC IQ-F FX5U Series User's Manual [Hardware]

→ MELSEC IQ-F FX5UC Series User's Manual [Hardware]

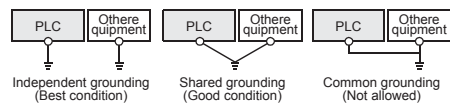

- The grounding wire size should be AWG 22 to 20 (0.3 to 0.5 mm²).
- The grounding point should be close to the PLC, and all grounding wire should be as short as possible.

4. Specifications

STARTUP AND MAINTENANCE PRECAUTIONS	CAUTION
<ul style="list-style-type: none"> Do not disassemble or modify the PLC. Doing so may cause fire, equipment failures, or malfunctions. For repair, contact your local Mitsubishi Electric representative. Do not drop the product or exert strong impact to it. Doing so may cause damage. 	

DISPOSAL PRECAUTIONS	CAUTION
<ul style="list-style-type: none"> Please contact a certified electronic waste disposal company for the environmentally safe recycling and disposal of your device. 	

TRANSPORTATION PRECAUTIONS	CAUTION
<ul style="list-style-type: none"> The product is a precision instrument. During transportation, avoid impacts larger than those specified in the general specifications by using dedicated packaging boxes and shock-absorbing pallets. Failure to do so may cause failures in the product. After transportation, verify operation of the product and check for damage of the mounting part, etc. 	

4.1 Applicable CPU module

Model name	Applicability
FX5U CPU module	Ver. 1.010 or later
FX5UC CPU module	Ver. 1.010 or later

4.2 General Specifications

The items other than the following are equivalent to those of the CPU module.
For general specifications, refer to the following manual.

→ MELSEC IQ-F FX5U User's Manual (Hardware)
→ MELSEC IQ-F FX5UC User's Manual (Hardware)

Item	Specification
Dielectric withstand voltage	500 V AC for one minute
Insulation resistance	10 MΩ or higher by 500 V DC insulation resistance tester

4.3 Power Supply Specifications

Item	Specification
External electric supply (D/A conversion circuit)	24 V DC +20 %/-15 % 160 mA External electric supply is carried out from the power supply connector of an adapter.
Internal electric supply (Interface)	5 V DC 10 mA Internal electric supply is carried out from 5 V DC power supply of a CPU module.

4.4 Performance Specifications

Item	Specification			
Number of analog output points	4 points (4 channels)			
Digital input	14-bit binary value			
Analog output voltage	-10 to +10 V DC (external load resistance value 1k to 1 MΩ)			
Analog output current	0 to 20 mA DC (external load resistance value 0 to 500 Ω)			
Output characteristics, resolution ^{*1}	Voltage	Analog output range	Digital value	Resolution
		0 to 10 V	0 to 16000	625 μV
		0 to 5 V	0 to 16000	312.5 μV
	1 to 5 V	0 to 16000	250 μV	
	-10 to +10 V	-8000 to +8000	1250 μV	
	Current	0 to 20 mA	0 to 16000	1.25 μA
4 to 20 mA		0 to 16000	1 μA	
Accuracy (accuracy for the full scale of the analog output value)	Ambient temperature 25±5°C: ±0.1 % (Voltage ±20 mV, Current ±20 μA) Ambient temperature 0 to 55°C: ±0.2 % (Voltage ±40 mV, Current ±40 μA)			
Conversion speed	Maximum 950 μs (The data will be updated at every scan time of the PLC.)			
Insulation method	Between output terminal and PLC: Photocoupler Between output channels: Non-isolation			
Number of occupied I/O points	0 point (This number is not related to the maximum number of I/O points of the PLC.)			

*1 For the output conversion characteristic, refer to the following.

→ MELSEC IQ-F FX5 User's Manual (Analog Control)

This manual confers no industrial property rights or any rights of any other kind, nor does it confer any patent licenses. Mitsubishi Electric Corporation cannot be held responsible for any problems involving industrial property rights which may occur as a result of using the contents noted in this manual.

Warranty

Mitsubishi will not be held liable for damage caused by factors found not to be the cause of Mitsubishi; opportunity loss or lost profits caused by faults in the Mitsubishi products; damage, secondary damage, accident compensation caused by special factors unpredictable by Mitsubishi; damages to products other than Mitsubishi products; and to other duties.

⚠ For safe use

- This product has been manufactured as a general-purpose part for general industries, and has not been designed or manufactured to be incorporated in a device or system used in purposes related to human life.
- Before using the product for special purposes such as nuclear power, electric power, aerospace, medicine or passenger movement vehicles, consult with Mitsubishi Electric.
- This product has been manufactured under strict quality control. However when installing the product where major accidents or losses could occur if the product fails, install appropriate backup or failsafe functions in the system.

MITSUBISHI ELECTRIC CORPORATION

HEAD OFFICE : TOKYO BUILDING, 2-7-3 MARUNOUCHI, CHIYODA-KU, TOKYO 100-8310, JAPAN