

# Altivar 71

Variable speed drives for  
synchronous motors and  
asynchronous motors

## Installation Manual

03/2011



55 kW (75 Hp) ... 75 kW (100 Hp) / 200 - 240 V  
90 kW (125 Hp) ... 500 kW (700 Hp) / 380 - 480 V  
90 kW (125 Hp) ... 630 kW (700 Hp) / 500 - 690 V



# Table of Contents

---

Important information	4
Before you begin	5
Steps for setting up the drive	6
Preliminary recommendations	7
Drive ratings	11
Dimensions and weights	14
Mounting the DC choke on the ●●●M3X and ATV71H●●●N4	17
Connecting the DC choke on ATV71H●●●M3X and ATV71H●●●N4 drives	18
Mounting the transformer(s) on ATV71H●●●Y drives	19
Connecting the transformer(s) on ATV71H●●●Y drives	20
Derating as a function of temperature and switching frequency	22
Mounting in a wall-mounted or floor-standing enclosure	25
Installing the kit for IP31/NEMA type 1 conformity	28
Position of the charging LED	30
Installing option cards	31
Wiring recommendations	33
Power terminals	35
Control terminals	52
Option terminals	54
Connection diagrams	60
Use on an IT system and corner grounded system	73
Electromagnetic compatibility, wiring	76

# Important information

---

## WARNING

Please read these instructions carefully and examine the equipment in order to familiarize yourself with the device before installing, operating or carrying out any maintenance work on it.

The following special messages that you will come across in this document or on the device are designed to warn you about potential risks or draw your attention to information that will clarify or simplify a procedure.



The addition of this symbol to a "Danger" or "Warning" safety label indicates that there is an electrical risk that will result in injury if the instructions are not followed.



This is a safety warning symbol. It warns you of potential risks of injury. You must comply with all safety messages that follow this symbol in order to avoid the risk of injury or death.

## DANGER

DANGER indicates an imminently hazardous situation which, if not avoided, **will result in** death, serious injury or equipment damage.

## WARNING

WARNING indicates a potentially hazardous situation which, if not avoided, **can result in** death, serious injury or equipment damage.

## CAUTION

CAUTION indicates a potentially hazardous situation which, if not avoided, **can result in** injury or equipment damage.

### PLEASE NOTE:

Only qualified personnel are authorized to carry out maintenance work on electrical equipment. Schneider Electric accepts no responsibility for the consequences of using this device. This document does not constitute an instruction manual for inexperienced personnel.  
© 2009 Schneider Electric. All rights reserved.

Read and understand these instructions before performing any procedure on this drive.

## DANGER

### RISK OF ELECTRIC SHOCK

- Read and understand this manual before installing or operating the Altivar 71 drive. Installation, adjustment, repair and maintenance must be performed by qualified personnel.
- The user is responsible for compliance with all international and national electrical standards in force concerning protective grounding of all equipment.
- Many parts of this variable speed drive, including the printed circuit boards, operate at the line voltage. **DO NOT TOUCH.**  
Use only electrically insulated tools.
- **DO NOT** touch unshielded components or terminal strip screw connections with voltage present.
- **DO NOT** short across terminals PA and PB or across the DC bus capacitors.
- Install and close all covers before applying power or starting and stopping the drive.
- Before servicing the variable speed drive
  - Disconnect all power.
  - Place a “DO NOT TURN ON” label on the variable speed drive disconnect.
  - Lock the disconnect in the open position.
- Disconnect all power including external control power that may be present before servicing the drive. Wait for the charging LED to go off. Then follow the DC bus voltage measurement procedure on page 28 to verify that the DC voltage is less than 45 V. The drive LEDs are not accurate indicators of the absence of DC bus voltage.

**Failure to follow these instructions will result in death or serious injury.**

## CAUTION

### IMPROPER DRIVE OPERATION

- If the drive is not turned on for a long period, the performance of its electrolytic capacitors will be reduced.
- If it is stopped for a prolonged period, turn the drive on every two years for at least 5 hours to restore the performance of the capacitors, then check its operation. It is recommended that the drive is not connected directly to the line voltage. The voltage should be increased gradually using an adjustable AC source.

**Failure to follow these instructions can result in injury and/or equipment damage.**

# INSTALLATION

### ■ 1 Receive and inspect the drive controller

- Check that the catalog number printed on the label is the same as that on the purchase order
- Remove the Altivar from its packaging and check that it has not been damaged in transit

### ■ 2 Check the line voltage

- Check that the line voltage is compatible with the voltage range of the drive (see pages [11](#) and [13](#))

### ■ 3 Mount the drive

- Mount the drive in accordance with the instructions in this document
- Install and connect the DC choke (see page [16](#)) or the transformer(s) (see page [19](#)) and the AC choke
- Install any internal and external options

### ■ 4 Wire the drive

- Connect the motor, ensuring that its connections correspond to the voltage
- Connect the line supply, after making sure that the power is off
- Connect the control
- Connect the speed reference

*Steps 1 to 4 must be performed with the power off.*



# PROGRAMMING

- 5** Please refer to the Programming Manual

# Preliminary recommendations

---

## On receipt

Package contents will vary depending on the model:

- ATV71H●●●M3X and ATV71H●●●N4 contain:
  - The drive and a DC choke mounted on the same pallet. The DC choke will comprise 1 to 3 components depending on the drive rating.
- ATV71H●●●M3XD and ATV71H●●●N4D contain:
  - The drive only.
- ATV71H●●●Y contains:
  - The drive and one or two DC chokes mounted on the same pallet.

## Handling/Storage

To protect the drive prior to installation, handle and store the device in its packaging. Ensure that the ambient conditions are acceptable.

 <b>WARNING</b>
<b>DAMAGED PACKAGING</b> If the packaging appears damaged, it can be dangerous to open it or handle it. Take precautions against all risks when opening or handling the packaging. <b>Failure to follow this instruction can result in death, serious injury or equipment damage.</b>

 <b>WARNING</b>
<b>DAMAGED EQUIPMENT</b> Do not install or operate any drive that appears damaged. <b>Failure to follow this instruction can result in death, serious injury or equipment damage.</b>

# Preliminary recommendations

## Unpacking/Handling ATV71H●●●M3X and ATV71H●●●N4 drives

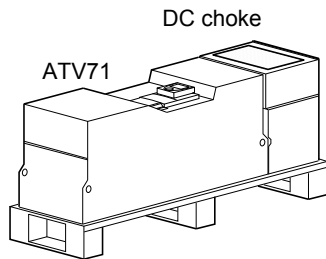

Figure 1

The drive and the DC choke are mounted on a pallet with screws (Figure 1). The DC choke is supplied already assembled to make it easier to transport. It will comprise 1 to 3 components depending on the drive rating. The unit should be unpacked in the following order:

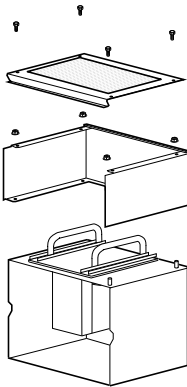

Figure 2

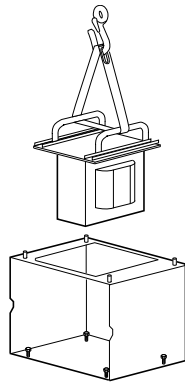

Figure 3

1 Disassemble the components of the DC choke (Figure 2) for installation later, and use a hoist to remove the choke (Figure 3).

2 Remove the fixing screws (Figure 3) from the choke support on the pallet.

### **WARNING**

#### **RISK OF CUTS**

The fixing screws that hold the choke support on the pallet are difficult to access, leading to a risk of cutting oneself. Take all possible measures to avoid this risk, and use protective gloves.

**Failure to follow this instruction can result in death, serious injury or equipment damage.**

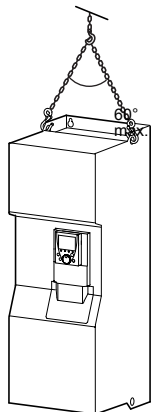

Figure 4

3 Remove the screws holding the drive on the pallet and use a hoist to lift the drive off. It has lifting lugs for this purpose (Figure 4).

### **WARNING**

#### **RISK OF TOPPLING**

Never stand the drive upright (Figure 5) without keeping hold of it, or it will topple over.

**Failure to follow this instruction can result in death, serious injury or equipment damage.**

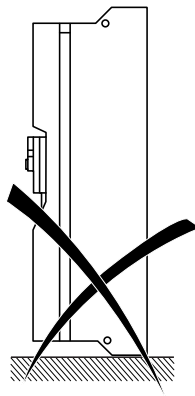

Figure 5

## Unpacking/Handling ATV71H●●●M3XD and ATV71H●●●N4D drives

As these models do not feature a DC choke, you only need to follow instruction 3 above.



# Preliminary recommendations

## Unpacking/Handling ATV71H●●●Y drives

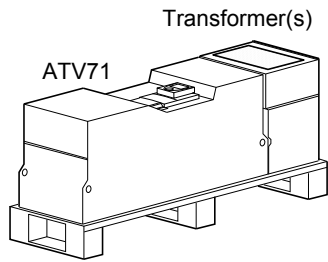

Figure 1

The drive and one or two transformers are mounted on a pallet with screws (Figure 1). The transformer(s) are supplied ready-assembled to make transport easier. The unit should be unpacked in the following order:

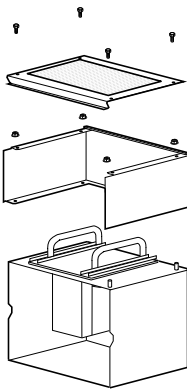

Figure 2

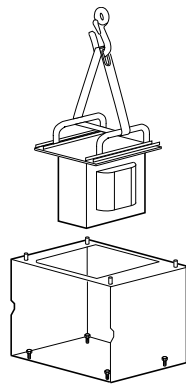

Figure 3

1 Disassemble the components of the transformer(s) (Figure 2) for installation later, and use a hoist to remove the transformer(s) (Figure 3).

2 Remove the fixing screws (Figure 3) from the transformer(s).

### **WARNING**

#### **RISK OF CUTS**

The fixing screws that hold the transformer(s) support on the pallet are difficult to access, leading to a risk of cutting oneself. Take all possible measures to avoid this risk, and use protective gloves.

**Failure to follow this instruction can result in death, serious injury or equipment damage.**

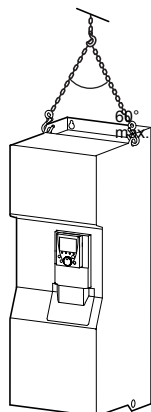

Figure 4

3 Remove the screws holding the drive on the pallet and use a hoist to lift it off. It has lifting lugs for this purpose (Figure 4).

### **WARNING**

#### **RISK OF TOPPLING**

Never stand the drive upright (Figure 5) without keeping hold of it, or it will topple over.

**Failure to follow this instruction can result in death, serious injury or equipment damage.**

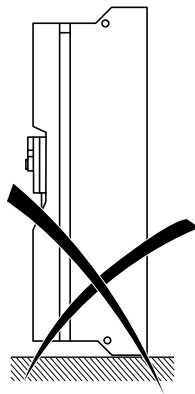

Figure 5

# Preliminary recommendations

---

## Installing the drive

- **Mount the drive first** on a wall or the back of the enclosure in accordance with the recommendations described in this document, before installing the DC choke or transformer(s).

## Installing the DC choke on ATV71H●●●M3X and ATV71H●●●N4 drives

ATV71H D55M3XD to D75M3XD and ATV71H D90N4D to C50N4D drives are not supplied with a DC choke. ATV71H D55M3X to D75M3X and ATV71H D90N4 to C50N4 drives are supplied with a DC choke that must be installed on top of the drive and wired in accordance with the recommendations described in this document. This choke must be used for connecting drives to the three-phase line supply.

- Mount the DC choke on the back of the enclosure or on the wall above the drive and connect it up. The instructions for installing and connecting the choke are given on page 16.
- Make sure that the seal between the drive and the choke chassis is doing its job properly.

## Installing the transformer(s) on ATV71H●●●Y drives

ATV71H C11Y to C63Y drives are supplied with one or two transformers for the fan power supply; these must be installed on top of the drive and wired in accordance with the recommendations described in this document.

## Installing the AC choke on ATV71H●●●Y drives

The use of an AC choke, which must be ordered separately, is mandatory on these drives if a special transformer is not used (e.g., 12-pulse).

## Recommendations

**Read and understand the instructions in the "Programming Manual".**

### CAUTION

#### **INCOMPATIBLE LINE VOLTAGE**

Before powering up and configuring the drive, ensure that the line voltage is compatible with the supply voltage shown on the drive nameplate. The drive may be damaged if the line voltage is not compatible.

**Failure to follow this instruction can result in injury and/or equipment damage.**

### DANGER

#### **UNINTENDED EQUIPMENT OPERATION**

- Before turning on and configuring the Altivar 71, check that the PWR (POWER REMOVAL) input is deactivated (at state 0) in order to prevent unintended operation. Do not forget to reactivate the Power Removal input to start the motor.
- Before turning on the drive, or when exiting the configuration menus, check that the inputs assigned to the run command are deactivated (at state 0) since they can cause the motor to start immediately.

**Failure to follow these instructions will result in death or serious injury.**



If the safety of personnel requires the prohibition of unwanted or unintended operation, provision for electronic locking is provided by the Altivar 71's Power Removal function.

This function requires the use of connection diagrams conforming to category 3 of standard EN 954-1, ISO 13849-1 and safety integrity level 2

according to IEC/EN 61508.

The Power Removal function takes priority over any run command.

# Drive ratings

## Powers in kW

### Three-phase supply voltage: 200...240 V 50/60 Hz

Three-phase motor 200..240 V

Motor	Line supply (input)				Drive (output)			Altivar 71
	Line current (2)		Max. prospective line Isc (4)	Apparent power	Max. available nominal current In (1)	Max. transient current (1) for		
	at 200 V	at 240 V				60 s	2 s	
Power indicated on plate (1)	A	A	kA	kVA	A	A	A	Catalog number (3)
kW								
55	202	176	35	71	221	332	365	<b>ATV71HD55M3X(5)</b>
75	274	237	35	95	285	428	470	<b>ATV71HD75M3X(5)</b>

### Three-phase supply voltage: 380...480 V 50/60 Hz

Three-phase motor 380...480 V

Motor	Line supply (input)				Drive (output)			Altivar 71
	Line current (2)		Max. prospective line Isc (4)	Apparent power	Max. available nominal current In (1)	Max. transient current (1) for		
	at 380 V	at 480 V				60 s	2 s	
Power indicated on plate (1)	A	A	kA	kVA	A	A	A	Catalog number (3)
kW								
90	166	134	35	109	179	268	295	<b>ATV71HD90N4(5)</b>
110	202	163	35	133	215	322	354	<b>ATV71HC11N4(5)</b>
132	239	192	35	157	259	388	427	<b>ATV71HC13N4(5)</b>
160	289	233	50	190	314	471	518	<b>ATV71HC16N4(5)</b>
200	357	286	50	235	387	580	638	<b>ATV71HC20N4(5)</b>
220	396	320	50	261	481	721	793	<b>ATV71HC25N4(5)</b>
250	444	357	50	292				
280	494	396	50	325	550	825	907	<b>ATV71HC28N4(5)</b>
315	555	444	50	365	616	924	1016	<b>ATV71HC31N4(5)</b>
355	637	512	50	419	759	1138	1252	<b>ATV71HC40N4(5)</b>
400	709	568	50	467				
500	876	699	50	577	941	1411	1552	<b>ATV71HC50N4(5)</b>

(1) These power ratings and currents are given for an ambient temperature of 50°C (122°F) at the factory-set switching frequency of 2.5 kHz, used in continuous operation.

Above 2.5 kHz, the drive will reduce the switching frequency automatically in the event of excessive temperature rise. For continuous operation above 2.5 kHz, derating must be applied to the nominal drive current in accordance with the curves on pages [22](#) and [23](#).

(2) Typical value for the indicated motor power, with a standard 4-pole motor on a line supply with the indicated "Max. prospective line Isc".

(3) The drives are supplied as standard with a DC choke, which must be used when connecting a drive to the three-phase supply. For connections to the DC bus, drives can be ordered without a DC choke by adding D at the end of the catalog number. For example, ATV 71HD90N4 becomes ATV 71HD90N4D.

(4) If the drive is installed on a line supply with a prospective short-circuit current that is higher than the value given in this column, use line chokes (please refer to the catalog).

(5) Drives with the extension 383 are intended for use with synchronous motors.

# Drive ratings

## Powers in HP

### Three-phase supply voltage: 200...240 V 50/60 Hz

Three-phase motor 200...240 V

Motor	Line supply (input)				Drive (output)			Altivar 71 Catalog number (3)
	Line current (2)		Max. prospective line Isc (4)	Apparent power	Max. available nominal current In (1)	Max. transient current (1) for		
	at 200 V	at 240 V				60 s	2 s	
HP	A	A	kA	kVA	A	A	A	
75	202	176	35	71	221	332	365	<b>ATV71HD55M3X(5)</b>
100	274	237	35	95	285	428	470	<b>ATV71HD75M3X(5)</b>

### Three-phase supply voltage: 460...480 V 50/60 Hz

Three-phase motor 460 V

Motor	Line supply (input)			Drive (output)			Altivar 71 Catalog number (3)	
	Line current (2)		Max. prospective line Isc (4)	Apparent power	Max. available nominal current In (1)	Max. transient current (1) for		
	at 460 V					60 s		2 s
HP	A	kA	kVA	A	A	A		
125	143	35	114	179	268	295	<b>ATV71HD90N4(5)</b>	
150	173	35	138	215	322	354	<b>ATV71HC11N4(5)</b>	
200	225	35	179	259	388	427	<b>ATV71HC13N4(5)</b>	
250	281	50	224	314	471	518	<b>ATV71HC16N4(5)</b>	
300	333	50	265	387	580	638	<b>ATV71HC20N4(5)</b>	
350	394	50	314	481	721	793	<b>ATV71HC25N4(5)</b>	
400	442	50	352					
450	494	50	394	550	825	907	<b>ATV71HC28N4(5)</b>	
500	547	50	436	616	924	1016	<b>ATV71HC31N4(5)</b>	
550	614	50	489	759	1138	1252	<b>ATV71HC40N4(5)</b>	
600	660	50	526					
700	761	50	606	941	1411	1552	<b>ATV71HC50N4(5)</b>	

(1) These power ratings and currents are given for an ambient temperature of 50°C (122°F) at the factory-set switching frequency of 2.5 kHz, used in continuous operation.

Above 2.5 kHz, the drive will reduce the switching frequency automatically in the event of excessive temperature rise. For continuous operation above 2.5 kHz, derating must be applied to the nominal drive current in accordance with the curves on pages [22](#) and [23](#).

(2) Typical value for the indicated motor power, with a standard 4-pole motor on a line supply with the indicated "Max. prospective line Isc".

(3) The drives are supplied as standard with a DC choke, which must be used when connecting a drive to the three-phase supply. For connections to the DC bus, drives can be ordered without a DC choke by adding D at the end of the catalog number. For example, ATV 71HD90N4 becomes ATV 71HD90N4D.

(4) If the drive is installed on a line supply with a prospective short-circuit current that is higher than the value given in this column, use line chokes (please refer to the catalog).

(5) Drives with the extension 383 are intended for use with synchronous motors.

# Drive ratings

## Powers in kW and HP

### Three-phase supply voltage: 500...690 V 50/60 Hz

Three-phase motor 500..690 V

Motor			Line supply (input)				Drive (output)			Altivar 71
Power indicated on plate (1)			Max. line current (2)			Max. prospective line Isc	Max. available nominal current In (1)			Catalog number (3)(4)
500 V	575 V	690 V	at 500 V	at 600 V	at 690 V		500 V	575 V	690 V	
kW	HP	kW	A	A	A	kA	A	A	A	
90	125	110	128	113	117	28	136	125	125	<b>ATV71HC11Y</b>
110	150	132	153	133	137	28	165	150	150	<b>ATV71HC13Y</b>
132	-	160	182	-	163	35	200	-	180	<b>ATV71HC16Y</b>
160	200	200	227	204	212	35	240	220	200	<b>ATV71HC20Y</b>
200	250	250	277	249	256	35	312	290	290	<b>ATV71HC25Y</b>
250	350	315	342	311	317	35	390	355	355	<b>ATV71HC31Y</b>
315	450	400	439	401	409	35	462	420	420	<b>ATV71HC40Y</b>
400	550	500	544	491	498	35	590	543	543	<b>ATV71HC50Y</b>
500	700	630	673	613	616	42	740	675	675	<b>ATV71HC63Y</b>

- (1) These power ratings and currents are given for an ambient temperature of 50°C (122°F) at the factory-set switching frequency of 2.5 kHz, used in continuous operation.  
Above 2.5 kHz, the drive will reduce the switching frequency automatically in the event of excessive temperature rise. For continuous operation above 2.5 kHz, derating must be applied to the nominal drive current in accordance with the curves on pages [24](#) and [25](#).
- (2) Typical value for the indicated motor power, with a standard 4-pole motor on a line supply with the indicated "Max. prospective line Isc".
- (3) The drives are supplied as standard with one or two transformers which must be used for the fan power supply.
- (4) The use of an AC choke, which must be ordered separately (please refer to the catalog), is mandatory on these drives if a special transformer is not used (e.g., 12-pulse).

#### Note:

The maximum transient current for 60 s corresponds to 150% of the maximum nominal current In.  
The maximum transient current for 2 s corresponds to 165% of the maximum nominal current In.

# Dimensions and weights

With 0 or 1 option card (1)

With 2 option cards (1)

ATV71H D55M3X, D75M3X,  
ATV71H D90N4 to C28N4

ATV71H C20N4 to C28N4 with braking unit

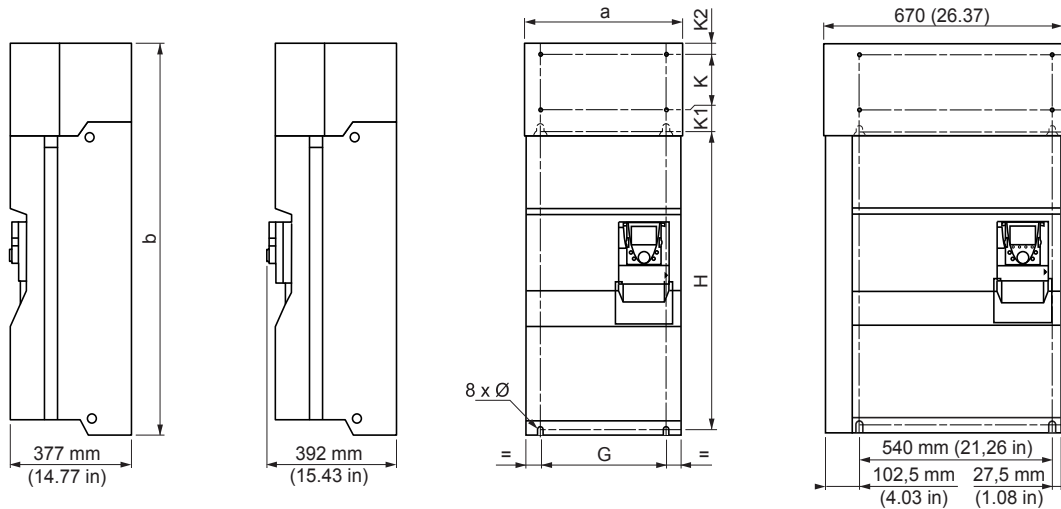

ATV71H	a mm (in.)	b mm (in.)	G mm (in.)	H mm (in.)	K mm (in.)	K1 mm (in.)	K2 mm (in.)	Ø mm (in.)	For screws	Weight kg (lb.)
<b>D55M3X, D90N4</b>	320 (12.60)	920 (36.22)	250 (9.84)	650 (25.59)	150 (5.91)	75 (2.95)	30 (1.18)	11.5 (0.45)	M10	100 (220)
<b>C11N4, D75M3X</b>	360 (14.17)	1022 (40.23)	298 (11.73)	758 (29.84)	150 (5.91)	72 (2.83)	30 (1.18)	11.5 (0.45)	M10	106 (234)
<b>C13N4</b>	340 (13.39)	1190 (46.62)	285 (11.22)	920 (36.22)	150 (5.91)	75 (2.95)	30 (1.18)	11.5 (0.45)	M10	116 (255)
<b>C16N4</b>	440 (17.32)	1190 (46.62)	350 (13.78)	920 (36.22)	150 (5.91)	75 (2.95)	30 (1.18)	11.5 (0.45)	M10	163 (358)
<b>C20N4, C25N4, C28N4</b>	595 (23.43)	1190 (46.62)	540 (21.26)	920 (36.22)	150 (5.91)	75 (2.95)	30 (1.18)	11.5 (0.45)	M10	207 (455)

With 0 or 1 option card (1)

With 2 option cards (1)

ATV71H C31N4 to C40N4

ATV71H C50N4

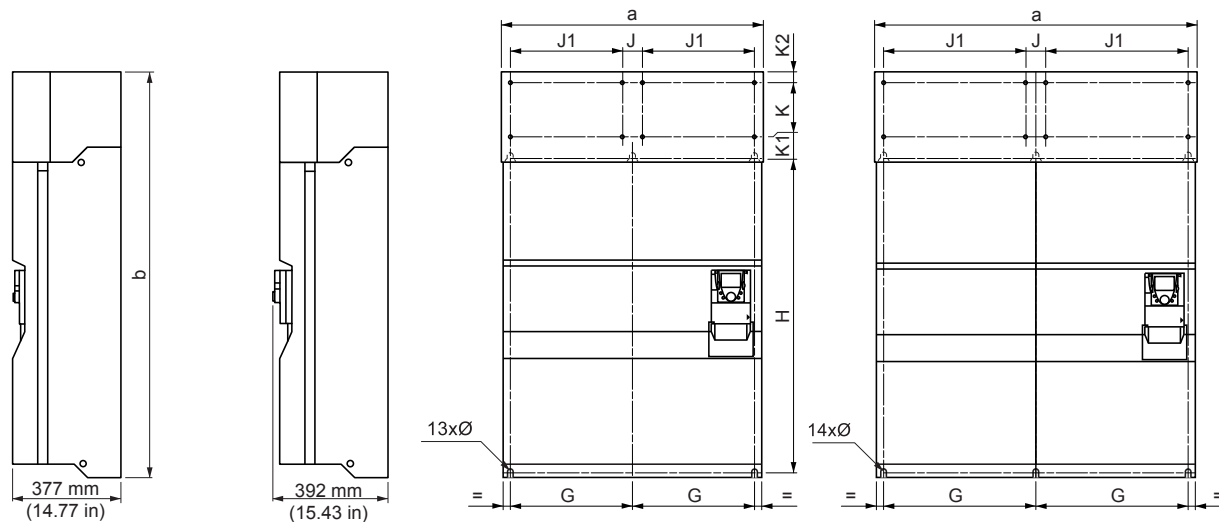

ATV71H	a mm (in.)	b mm (in.)	G mm (in.)	J mm (in.)	J1 mm (in.)	H mm (in.)	K mm (in.)	K1 mm (in.)	K2 mm (in.)	Ø mm (in.)	For screws	Weight kg (lb.)
<b>C31N4</b>	890 (35.04)	1390 (54.72)	417.5 (16.44)	70 (2.76)	380 (14.96)	1120 (44.09)	150 (5.91)	75 (2.95)	30 (1.18)	11.5 (0.45)	M10	320 (704)
<b>C40N4</b>	890 (35.04)	1390 (54.72)	417.5 (16.44)	70 (2.76)	380 (14.96)	1120 (44.09)	150 (5.91)	75 (2.95)	30 (1.18)	11.5 (0.45)	M10	330 (726)
<b>C50N4</b>	1120 (44.09)	1390 (54.72)	532.5 (20.96)	70 (2.76)	495 (19.49)	1120 (44.09)	150 (5.91)	75 (2.95)	30 (1.18)	11.5 (0.45)	M10	435 (957)

(1) For the addition of I/O extension cards, communication cards or the "Controller Inside" programmable card.

# Dimensions and weights

With 0 or 1 option card (1)

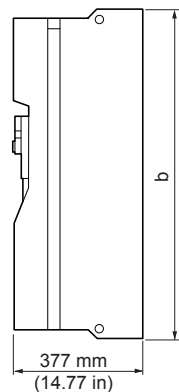

With 2 option cards (1)

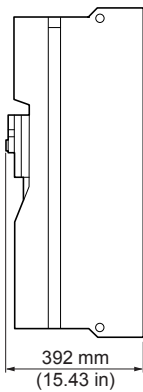

ATV71H D55M3XD, D75M3XD  
ATV71H D90N4D to C28N4D

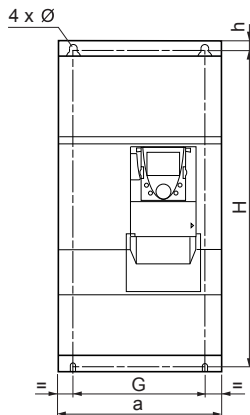

ATV71H C20N4D to C28N4D  
with braking unit (VW3A7 101)

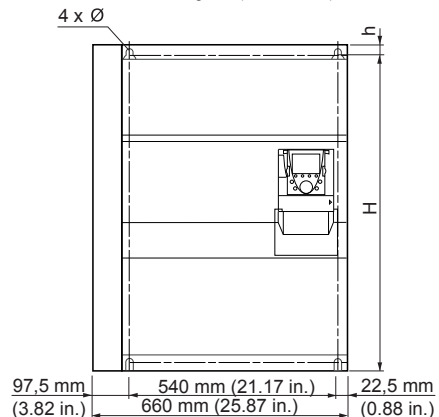

ATV71H	a mm (in.)	b mm (in.)	G mm (in.)	H mm (in.)	h mm (in.)	Ø mm (in.)	For screws	Weight kg (lb.)
<b>D55M3XD, D90N4D</b>	310 (12.20)	680 (26.77)	250 (9.84)	650 (25.59)	15 (0.59)	11.5 (0.45)	M10	76 (168)
<b>C11N4D, D75M3XD</b>	350 (13.78)	782 (30.79)	298 (11.73)	758 (29.84)	12 (0.47)	11.5 (0.45)	M10	90 (198)
<b>C13N4D</b>	330 (12.99)	950 (37.4)	285 (11.22)	920 (36.22)	15 (0.59)	11.5 (0.45)	M10	80 (176)
<b>C16N4D</b>	430 (16.33)	950 (37.4)	350 (13.78)	920 (36.22)	15 (0.59)	11.5 (0.45)	M10	110 (242)
<b>C20N4D, C25N4D, C28N4D</b>	585 (23.03)	950 (37.4)	540 (21.26)	920 (36.22)	15 (0.59)	11.5 (0.45)	M10	140 (309)

With 0 or 1 option card (1)

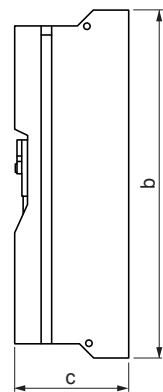

With 2 option cards (1)

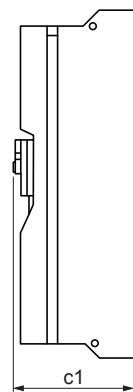

ATV71H C31N4D to C40N4D

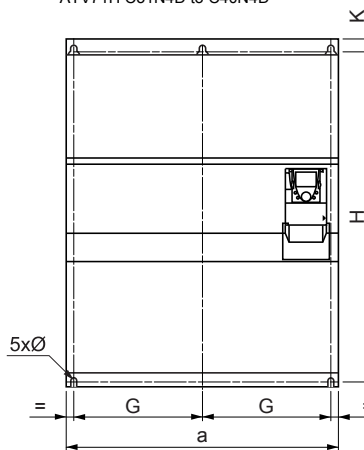

ATV71H C50N4D

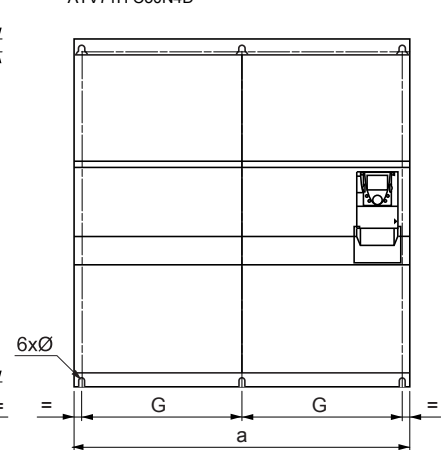

ATV71H	a mm (in.)	b mm (in.)	G mm (in.)	H mm (in.)	F mm (in.)	Ø mm (in.)	For screws	Weight kg (lb.)
<b>C31N4D</b>	880 (35.65)	1150 (54.72)	417.5 (16.44)	1120 (44.09)	415 (16.34)	11.5 (0.45)	M10	215 (474)
<b>C40N4D</b>	880 (35.65)	1150 (54.72)	417.5 (16.44)	1120 (44.09)	415 (16.34)	11.5 (0.45)	M10	225 (496)
<b>C50N4D</b>	1110 (43.49)	1150 (54.72)	532.5 (20.96)	1120 (44.09)	532.5 (20)	11.5 (0.45)	M10	300 (661)

(1) For the addition of I/O extension cards, communication cards or the "Controller Inside" programmable card.

# Dimensions and weights

With 0 or 1 option card (1)

With 2 option cards (1)

ATV71H C11Y to C16Y

ATV71HC20Y to C31Y with braking unit

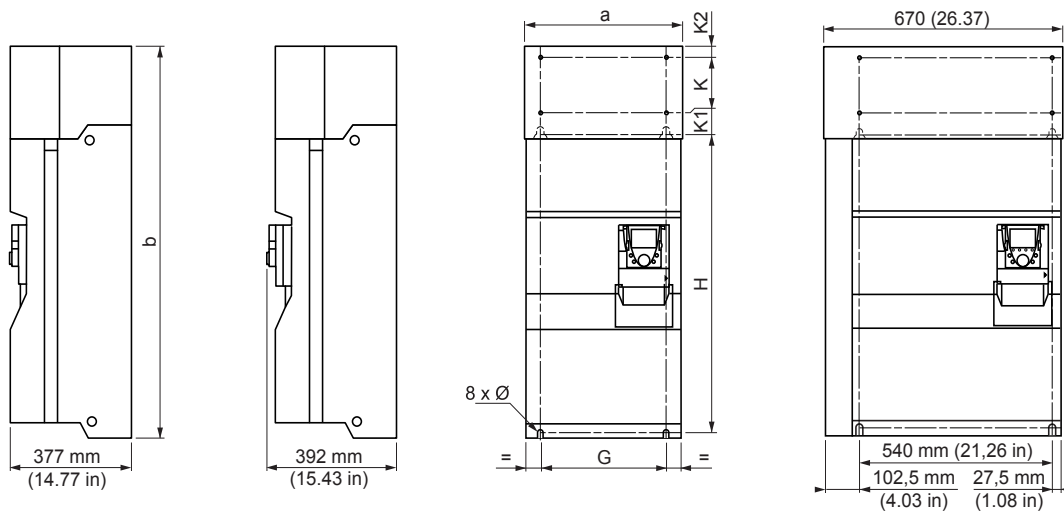

ATV71H	a	b	G	H	K	K1	K2	Ø	For screws	Weight
	mm (in.)	mm (in.)	mm (in.)	mm (in.)	mm (in.)	mm (in.)	mm (in.)	mm (in.)		kg (lb.)
<b>C11Y to C16Y</b>	340 (13.39)	1190 (46.62)	285 (11.22)	920 (36.22)	150 (5.91)	75 (2.95)	30 (1.18)	11.5 (0.45)	M10	102 (225)
<b>C20Y to C31Y</b>	595 (23.43)	1190 (46.62)	540 (21.26)	920 (36.22)	150 (5.91)	75 (2.95)	30 (1.18)	11.5 (0.45)	M10	181 (399)

With 0 or 1 option card (1)

With 2 option cards (1)

ATV71HC40Y to C63Y

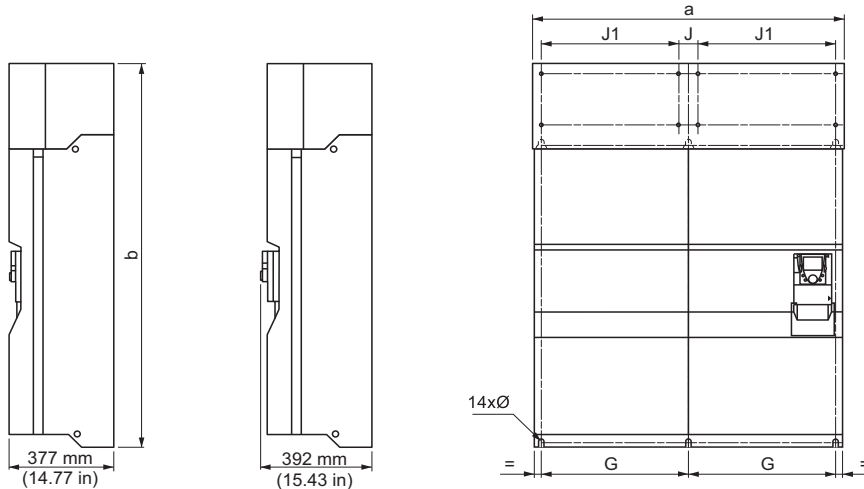

ATV71H	a	b	G	J	J1	H	K	K1	K2	Ø	For screws	Weight
	mm (in.)	mm (in.)	mm (in.)	mm (in.)	mm (in.)	mm (in.)	mm (in.)	mm (in.)	mm (in.)	mm (in.)		kg (lb.)
<b>C40Y to C63Y</b>	1120 (44.09)	1390 (54.72)	532.5 (20.96)	70 (2.76)	495 (19.49)	1120 (44.09)	150 (5.91)	75 (2.95)	30 (1.18)	11.5 (0.45)	M10	383 (844)

(1) For the addition of I/O extension cards, communication cards or the "Controller Inside" programmable card.



# Mounting the DC choke on the ●●●M3X and ATV71H●●●N4

This should be performed after mounting the drive and before wiring it. If a VW3 A7 101 braking module is being used, install the module on the drive before mounting the DC choke.  
During installation, ensure that no liquid, dust or conductive objects fall into the drive.

## Example of mounting DC chokes on an ATV71HC16N4 drive

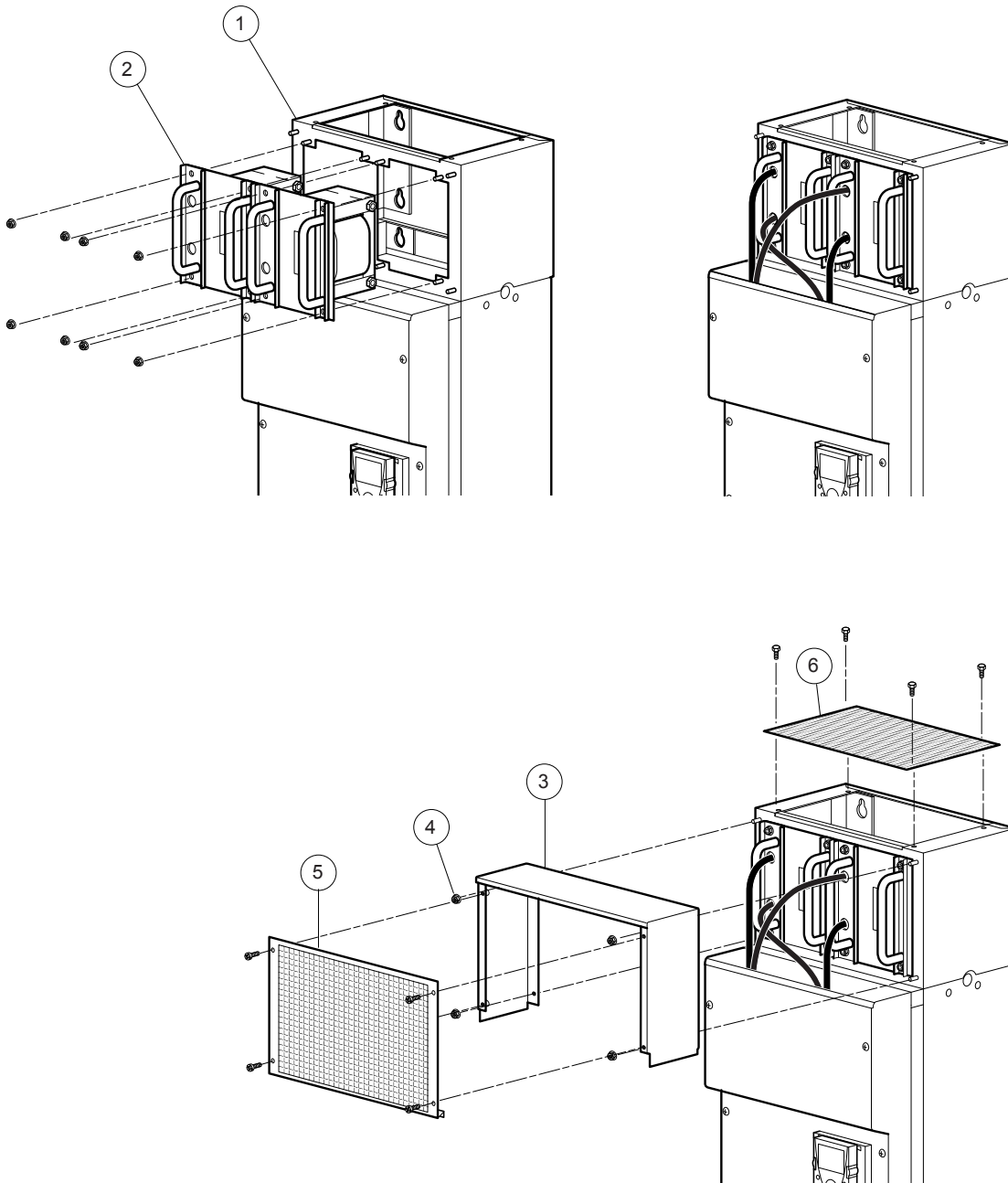

- Mount the DC choke chassis ① on the wall, on top of the drive. Ensure that the chassis is tightly secured to the drive to maintain the IP54 seal of the ventilation duct.
- Then install the DC choke ② on the chassis ① using the nuts provided.
- Connect the choke between the PO and PA+ terminals on the drive (see note and next page).
- Connect the grounding strip between the DC choke chassis ① and the drive.
- Then mount the cover ③ on the chassis and secure it with the nuts ④ provided.
- Then mount panels ⑤ and ⑥ using the screws provided.

Once the choke has been installed, the degree of protection of the top the drive is IP31.

**Note:** The number of DC chokes supplied with the drive varies according to the drive rating.

# Connecting the DC choke on ATV71H...M3X and ATV71H...N4 drives

Between 1 and 4 chokes can be connected in parallel as described in the following examples.

## Table of drive/choke combinations

Drive	Number of chokes in parallel	Choke model
ATV71HD55M3X	1	DC-CHOKE 5
ATV71HD75M3X	1	DC-CHOKE 6
ATV71HD90N4	1	DC-CHOKE 1
ATV71HC11N4	1	DC-CHOKE 2
ATV71HC13N4	1	DC-CHOKE 4
ATV71HC16N4	2	DC-CHOKE 1
ATV71HC20N4	2	DC-CHOKE 3
ATV71HC25N4, C28N4	2	DC-CHOKE 4
ATV71HC31N4	3	DC-CHOKE 3
ATV71HC40N4	4	DC-CHOKE 2
ATV71HC50N4	4	DC-CHOKE 7

**Example 1:**  
ATV71H D55M3X ... D75M3X,  
ATV71H D90N4 ... C13N4

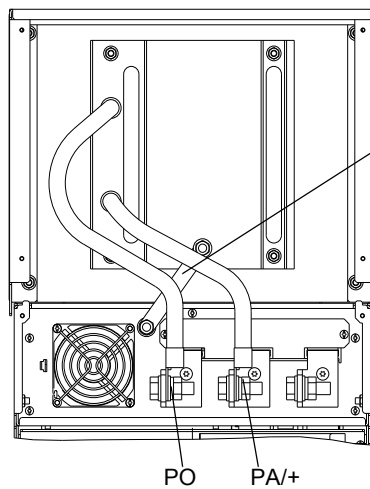

**Example 3:**  
ATV71HC31N4

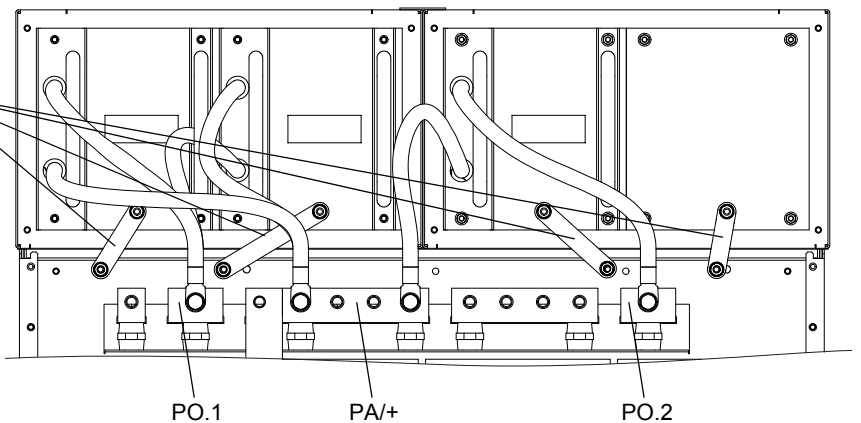

**Example 2:** ATV71H C16N4 ... C28N4

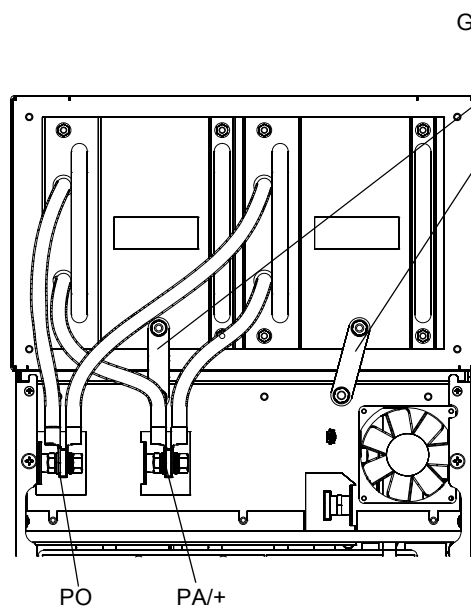

**Example 4:** ATV71H C40N4 ... C50N4

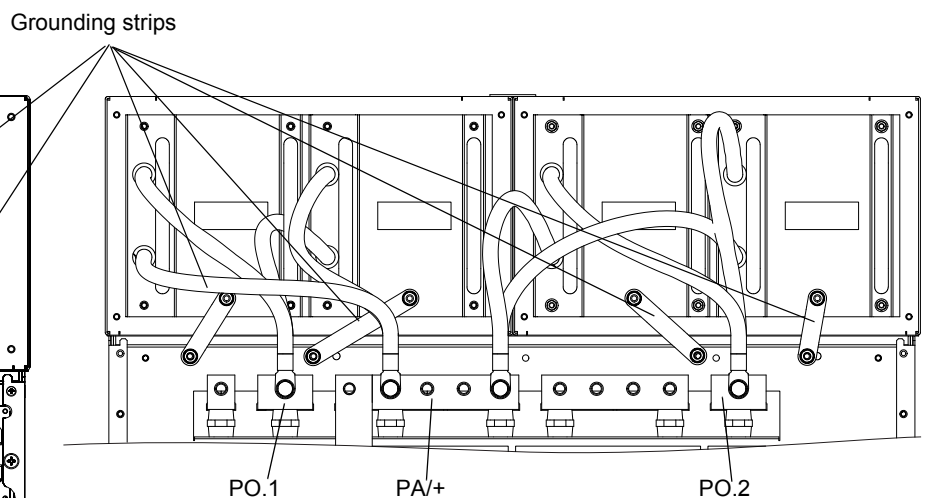

# Mounting the transformer(s) on ATV71H●●●Y drives

This should be performed after mounting the drive and before wiring it.  
During installation, ensure that no liquid, dust or conductive objects fall into the drive.

## Example of mounting a transformer on an ATV71HC20Y drive

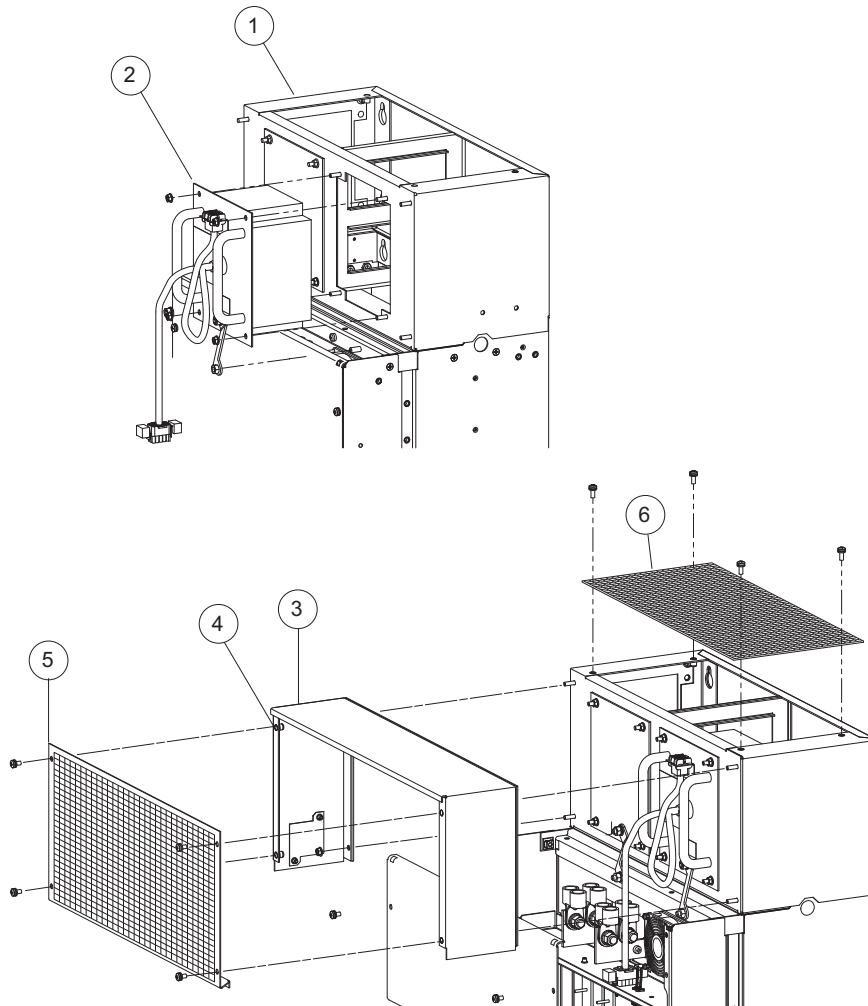

- Mount the transformer chassis (1) on the wall, on top of the drive. Ensure that the chassis is tightly secured to the drive to maintain the IP54 seal of the ventilation duct.
- Then mount the transformer (2) on the chassis (1) using the nuts provided.
- Connect the transformer connector on the drive (see next page).
- Connect the grounding strips between the transformer chassis (1) and the drive.
- Then mount the cover (3) on the chassis and secure it with the nuts (4) provided.
- Then mount panels (5) and (6) using the screws provided.

Once the transformer has been installed, the degree of protection of the top the drive is IP31.

### Location of transformers:

ATV71 HC11Y to HC16Y: One transformer



ATV71 HC20Y to HC31Y: One transformer



ATV71 HC40Y to HC63Y: Two transformers



# Connecting the transformer(s) on ATV71H●●●Y drives

1 to 2 chokes can be connected as described in the following examples.

## Table of drive/transformer combinations

Drive	Number of transformers
ATV71HC11Y to HC16Y	1
ATV71HC20Y to HC31Y	1
ATV71HC40Y to HC63Y	2

### Example 1: ATV71H C11Y ... C16Y

### Example 2: ATV71H C20Y ... C31Y

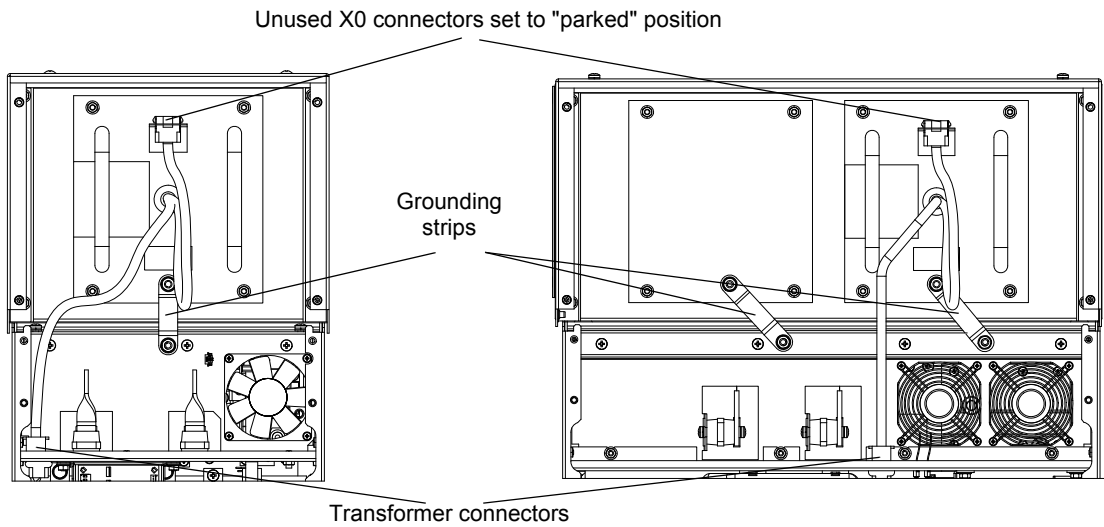

### Example 3: ATV71H C40Y ... C63Y

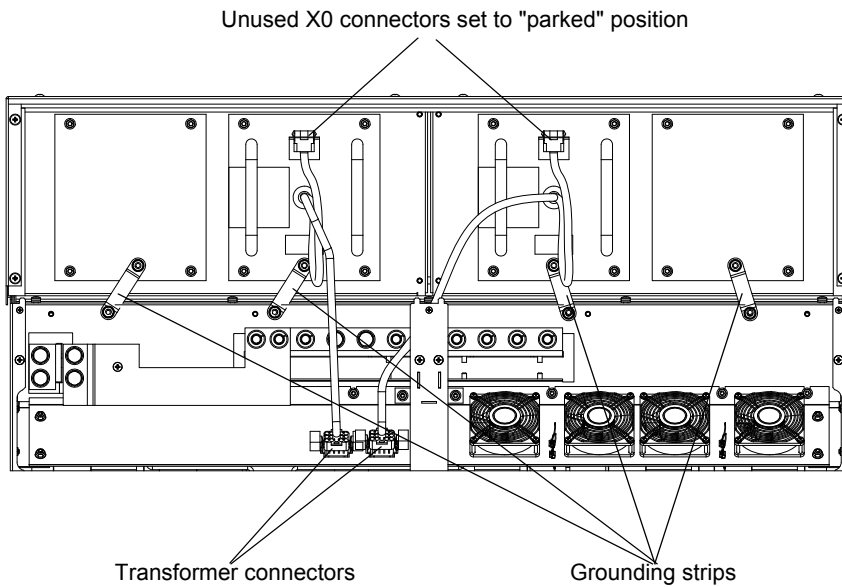

# Connecting the transformer(s) on ATV71H●●●Y drives

Each transformer features one 500 V/600 V connector and one 690 V connector. Connect the connector appropriate for the line supply (see above). Set the unused connector to the parked position.

**Connection of a transformer (500 V/50 Hz or 600 V/60 Hz line): Use X2A.**

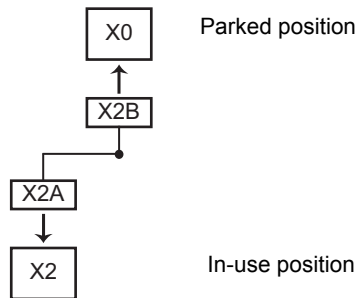

**Connection of a transformer (690 V/50 Hz line): Use X2B.**

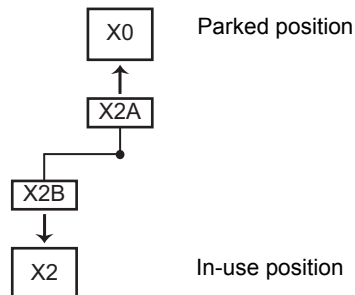

ATV71HC40Y to ATV71HC63Y drives feature 2 transformers. Make this connection for each transformer.

## CAUTION

### IMPROPER WIRING PRACTICES

Making a connection inappropriate for the line voltage will damage the transformer(s) and the ATV71.

**Failure to follow this instruction can result in injury and/or equipment damage.**

# Derating as a function of temperature and switching frequency

Derating curves for the drive current  $I_n$  as a function of temperature and switching frequency.

**ATV71HD55M3X, HD75M3X**

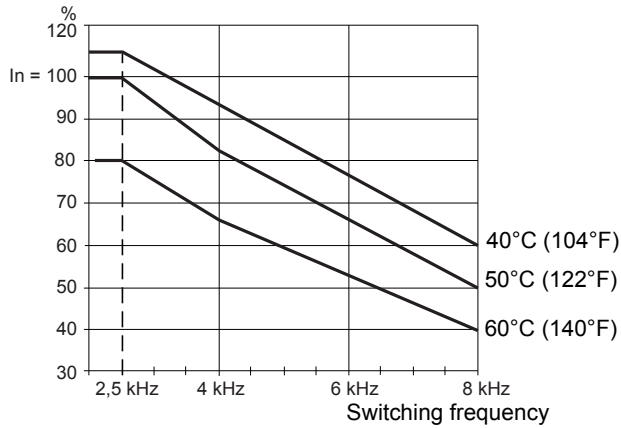

**ATV71HD90N4**

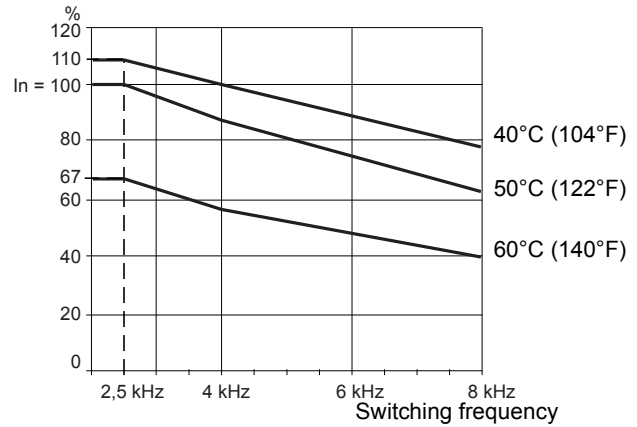

**ATV71HC11N4**

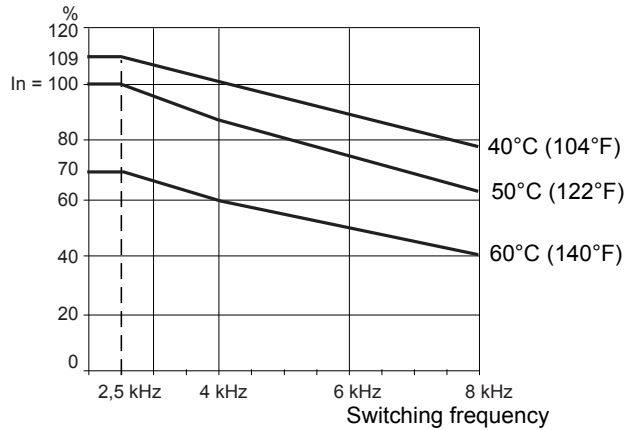

**ATV71HC13N4**

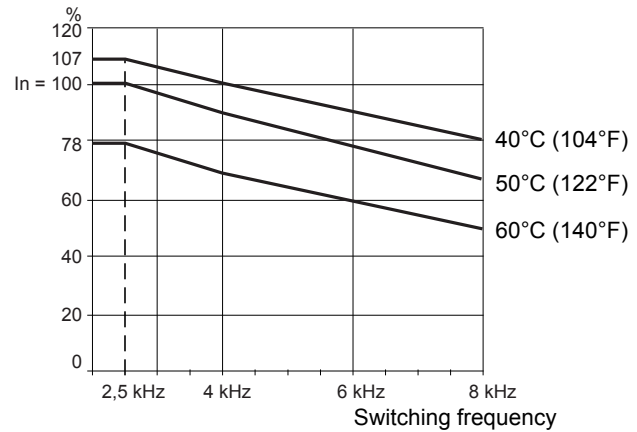

**ATV71HC16N4**

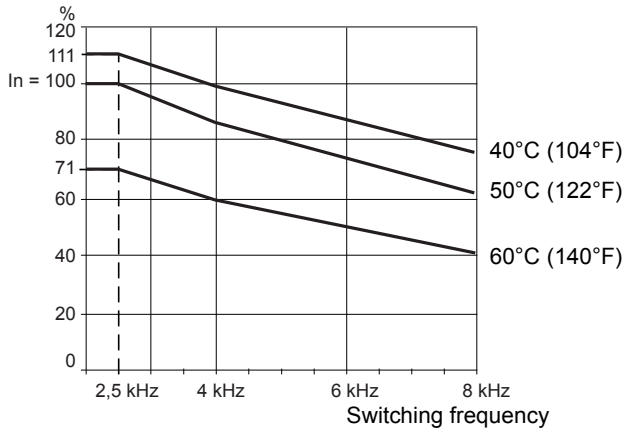

**ATV71HC20N4**

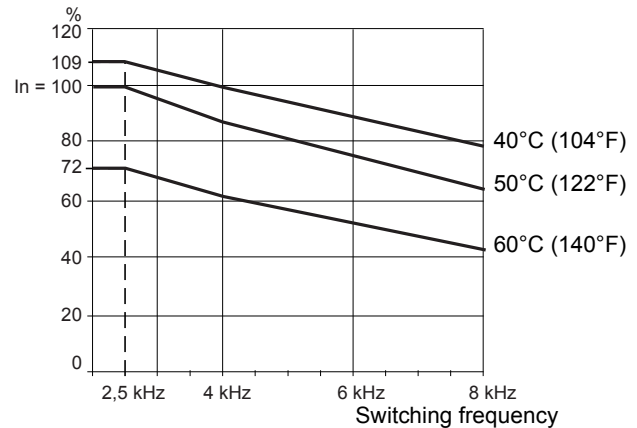

For intermediate temperatures (e.g., 55°C (131°F)), interpolate between two curves.

# Derating as a function of temperature and switching frequency

**ATV71HC25N4**

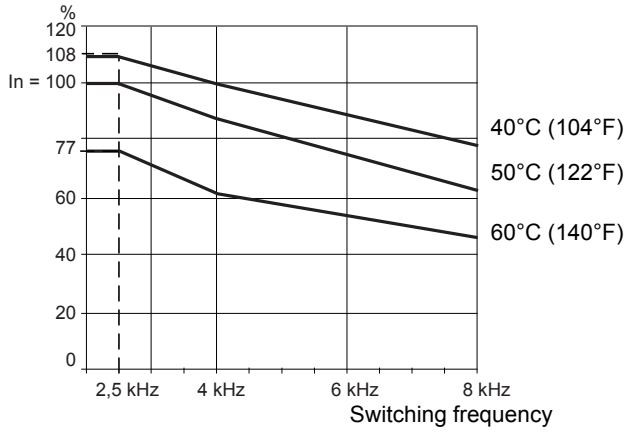

**ATV71HC28N4**

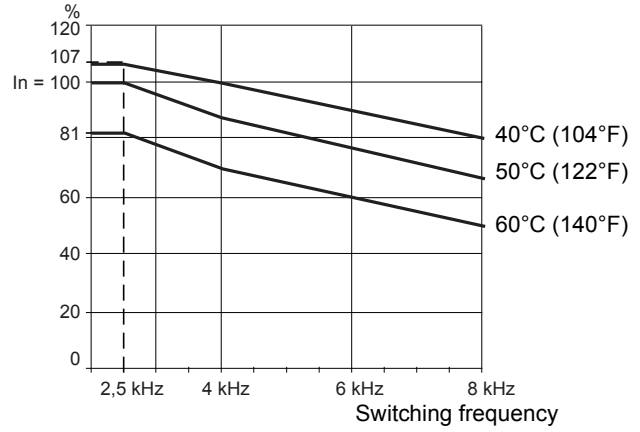

**ATV71HC31N4**

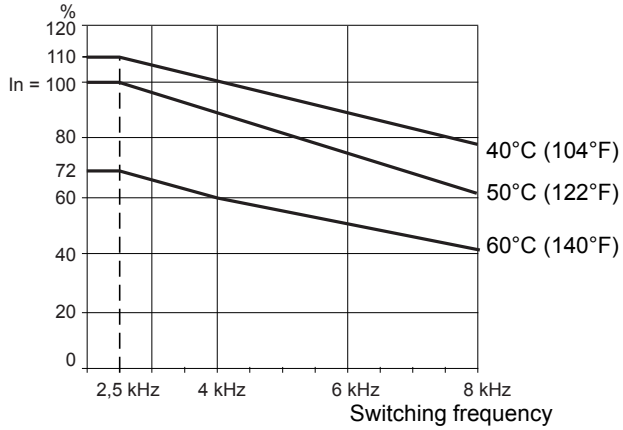

**ATV71HC40N4**

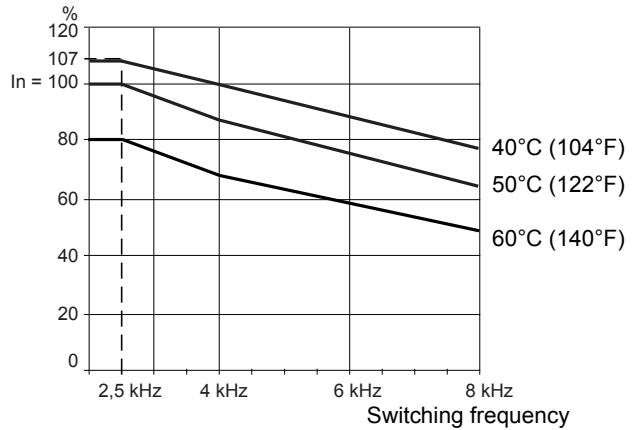

**ATV71HC50N4**

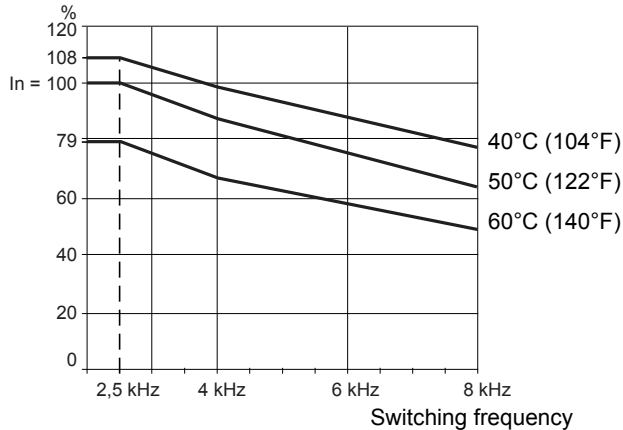

For intermediate temperatures (e.g., 55°C (131°F)), interpolate between two curves.

# Derating as a function of temperature and switching frequency

**ATV71HC11Y**

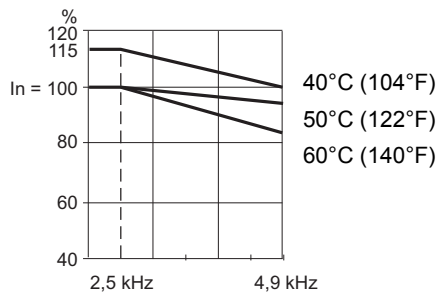

Switching frequency

**ATV71HC13Y**

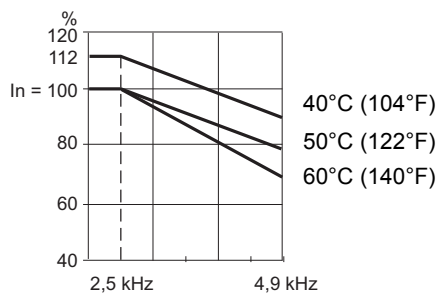

Switching frequency

**ATV71HC16Y**

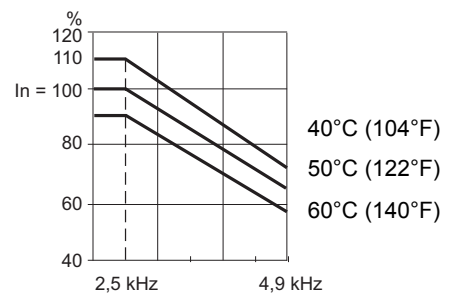

Switching frequency

**ATV71HC20Y**

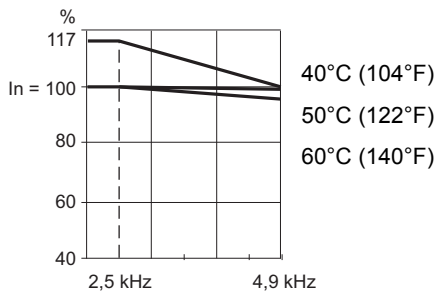

Switching frequency

**ATV71HC25Y**

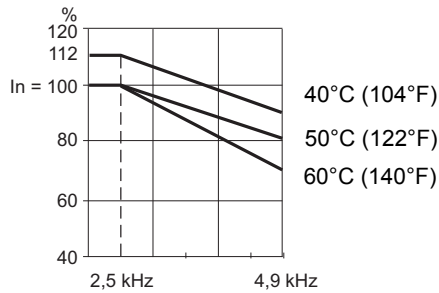

Switching frequency

**ATV71HC31Y**

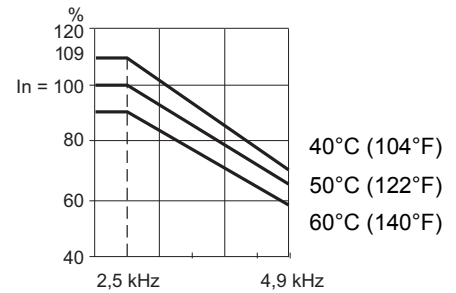

Switching frequency

**ATV71HC40Y**

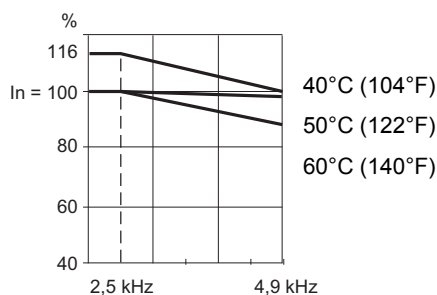

Switching frequency

**ATV71HC50Y**

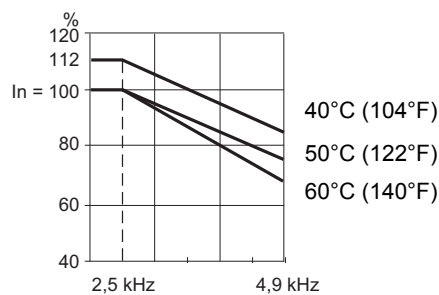

Switching frequency

**ATV71HC63Y**

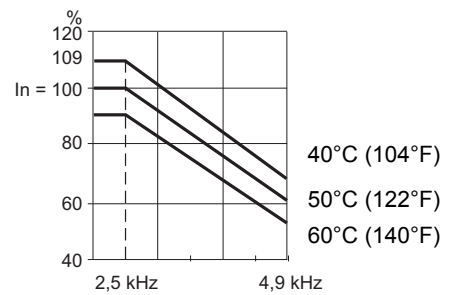

Switching frequency

For intermediate temperatures (e.g., 55°C (131°F)), interpolate between two curves.



# Mounting in a wall-mounted or floor-standing enclosure

Install the drive vertically at  $\pm 10^\circ$ . Do not place it close to heating elements.

## Mounting with the heatsink inside the enclosure

The power dissipated by the drive power components is given in the table below.

### Dissipated power

These levels of power dissipation are given for operation at nominal load and for a switching frequency of 2.5 kHz.

ATV71H	Dissipated power W	ATV71H	Dissipated power W	ATV71H	Dissipated power W	ATV71H	Dissipated power W
D55M3X	1715	C20N4	4930	C11Y	2320	C40Y	7596
D75M3X	2204	C25N4	5873	C13Y	2739	C50Y	9614
D90N4	2403	C28N4	6829	C16Y	3271	C63Y	11921
C11N4	2726	C31N4	7454	C20Y	4005		
C13N4	3191	C40N4	9291	C25Y	5142		
C16N4	3812	C50N4	11345	C31Y	6293		

The drive has a fan for cooling the power components. The air is circulated from the bottom to the top of the unit via a duct (the duct is shown shaded gray in the diagram below). This duct is isolated from the control section by IP54 protection. The DC choke (ATV71H●●●M3X, ATV71H●●●N4) extends the duct while maintaining the IP54 protection.

The drive dissipates a great deal of power which must be evacuated to the outside of the enclosure.

Air inlets and outlets must be provided to ensure that the flow of air in the enclosure is at least equal to the value given in the table below for each drive.

ATV71H	Flow rate	
	m <sup>3</sup> /hour	ft <sup>3</sup> /min
D55M3X, D90N4	402	236
D75M3X, C11N4	774	455
C13N4	745	438
C16N4	860	506
C20N4, C25N4, C28N4	1260	742
C31N4, C40N4	2100	1236
C50N4	2400	1412

ATV71H	Flow rate	
	m <sup>3</sup> /hour	ft <sup>3</sup> /min
C11Y, C13Y, C16Y	600	353
C20Y, C25Y, C31Y	1200	706
C40Y, C50Y, C63Y	2400	1412

Several methods of evacuation are possible. The following is a proposed method for IP23 and IP54 mounting.

Figure 1

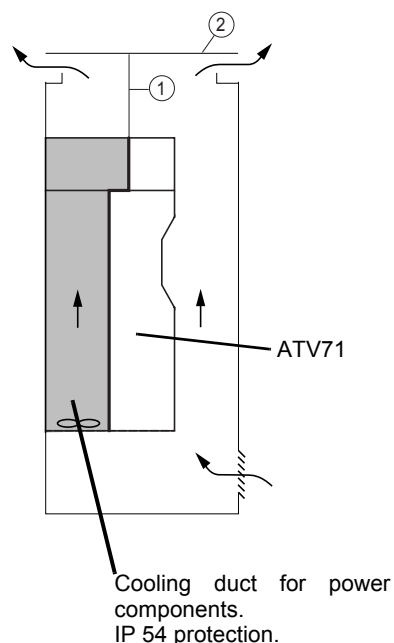

### IP23 mounting (standard operating conditions):

#### Figure 1

Install the drive on an enclosure baseplate.

Install the DC choke (ATV71H●●●M3X, ATV71H●●●N4) or the transformer(s) (ATV71H●●●Y) in accordance with the mounting recommendations.

The simplest mounting method is to extend the IP54 duct between the upper outlet of the DC choke (or transformer) and the top of the enclosure (1). Fixing points are provided for this purpose on the top of the DC choke (or transformer).

The hot air is thus evacuated to the outside and does not contribute towards increasing the internal temperature of the enclosure.

It is advisable to add a plate (2) approximately 150 mm from the top of the enclosure over the air outlet opening to prevent foreign bodies falling into the drive cooling duct.

The air inlet can be via a grille on the bottom front panel of the enclosure door, in accordance with the required flow rates given in the above table.

#### Note:

- If the air in the power circuit is totally evacuated to the outside, very little power is dissipated inside the enclosure. In this case, use the dissipated power table for dust and damp proof flange mounting (see the next page).
- Connect all the additional metal parts to ground via grounding strips.

# Mounting in a wall-mounted or floor-standing enclosure

## Mounting the heatsink inside the enclosure (continued)

Figure 2

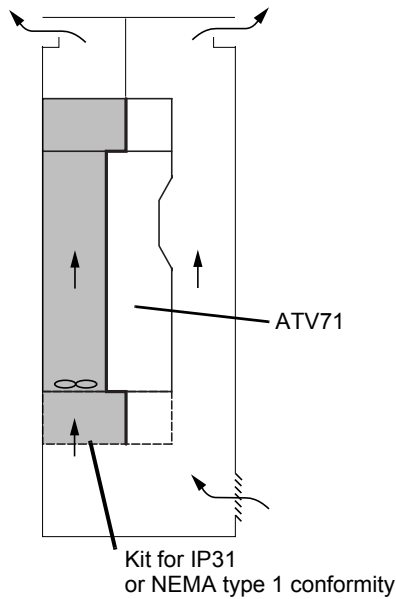

### IP23 mounting (standard operating conditions, continued):

Figure 2

It is advisable to use a kit for IP31/NEMA type 1 conformity (to be ordered as an option) for attaching the power cables. The design of the IP31 kit is based on the same principle as the DC choke, and has an IP54 duct to help guide the incoming air.

**Note:**

- If the air in the power circuit is totally evacuated to the outside, very little power is dissipated inside the enclosure. In this case, use the dissipated power table for dust and damp proof flange mounting (see below).
- Connect all the additional metal parts to ground via grounding strips.

Figure 3

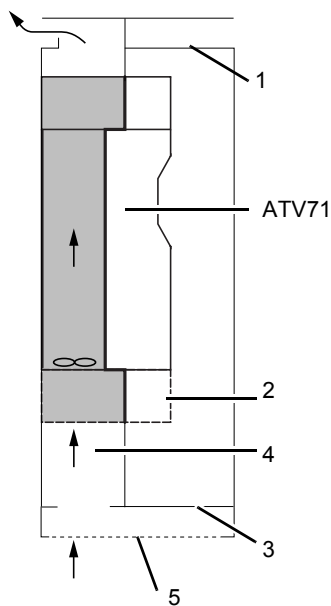

### IP54 mounting (standard operating conditions):

The drive must be mounted in an IP54 enclosure in certain environmental conditions: dust, corrosive gases, high humidity with risk of condensation and dripping water, splashing liquid, etc.

The simplest way of obtaining an enclosure with IP54 protection is to follow the mounting recommendations for IP23 protection with the following additional points (Figure 3):

- 1 Do not make an air outlet hole for the control section. Do not make an air inlet hole in the enclosure door. In the power section, the air will enter through the bottom of the enclosure via a plinth added for this purpose.
- 2 Add the IP31 or NEMA type 1 conformity kit in accordance with the mounting instructions.
- 3 Add an enclosure baseplate designed to provide IP54 protection around the power cables.
- 4 Add an air evacuation duct between the baseplate and the duct of the IP31 or NEMA type 1 conformity kit. The IP31 or NEMA type 1 conformity kit enables an extension duct to be mounted. Drill a hole in the base of the enclosure to allow air to enter. Place seals around the duct that has been added to maintain IP54 protection.
- 5 Add a 200 mm plinth at the bottom of the enclosure with grilles to allow air to enter.
- 6 Use the dissipated power table below to calculate the enclosure dimensions.

**Note:** Connect all the additional metal parts to ground via grounding strips.

## Power dissipated by the control section inside the enclosure (for calculating the enclosure dimensions)

These levels of power dissipation are given for operation at nominal load and for the factory-set switching frequency.

ATV71H	Dissipated power (1)	ATV71H	Dissipated power (1)	ATV71H	Dissipated power (1)	ATV71H	Dissipated power (1)
	W		W		W		W
D55M3X	154	C20N4	493	C11Y	169	C40Y	471
D75M3X	154	C25N4	586	C13Y	179	C50Y	554
D90N4	237	C28N4	658	C16Y	196	C63Y	658
C11N4	261	C31N4	772	C20Y	267		
C13N4	296	C40N4	935	C25Y	311		
C16N4	350	C50N4	1116	C31Y	363		

(1) Add 7 W to this value for each option card added

# Mounting in a wall-mounted or floor-standing enclosure

## Dust and damp proof flange mounting (heatsink outside the enclosure)

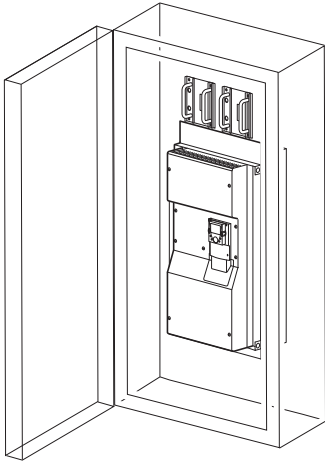

This mounting is used to reduce the power dissipated in the enclosure by locating the power section outside the enclosure.

This requires the use of a dust and damp proof flange mounting kit VW3A9509...517 (please refer to the catalog).

The degree of protection of drives mounted in this way becomes IP54.

To install the kit on the drive, please refer to the manual supplied with the kit.

Check that the back of the enclosure is strong enough to support the weight of the drive.

Use the dissipated power table on the previous page to calculate the enclosure dimensions.

In this case the DC choke (ATV71H●●●M3X, ATV71H●●●N4) or transformer (ATV71H●●●Y) can be mounted directly on the back of the enclosure.

If the hot air exiting the drive is not ducted and evacuated to the outside, it risks being sucked back in, rendering the ventilation totally ineffective. In order to avoid this, it is important to leave enough free space around the drive, as indicated below. The enclosure must be cooled in order to evacuate the dissipated heat.

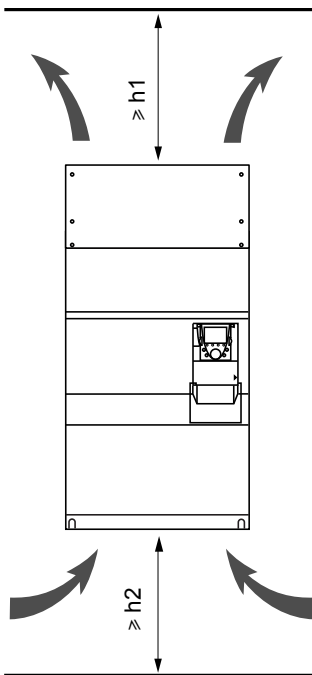

ATV71H	h1		h2	
	mm	in.	mm	in.
D55M3X, D75M3X, D90N4	100	3.94	100	3.94
C11N4 ... C16N4, C11Y ... C16Y	150	5.90	150	5.90
C20N4 ... C28N4, C20Y ... C31Y	200	7.87	150	5.90
C31N4 ... C40N4	300	11.81	250	9.84
C50N4, C40Y ... C63Y	400	15.75	250	9.84

Free space in front of the drive: 10 mm (0.39 in.), minimum

## Installing the kit for IP31/NEMA type 1 conformity

On ATV71H D55M3X to D75M3X and D90N4 to C50N4 and C11Y to C63Y drives, cable shielding can be attached and connected to ground using one of the following two kits:

- Kit for IP31 conformity (VW3 A9 109 ... 116)
- Kit for NEMA type 1 conformity (VW3 A9 209 ... 214)

This kit is not supplied with the drive. It must be ordered separately (please refer to the catalog). It is mounted under the drive as shown below.

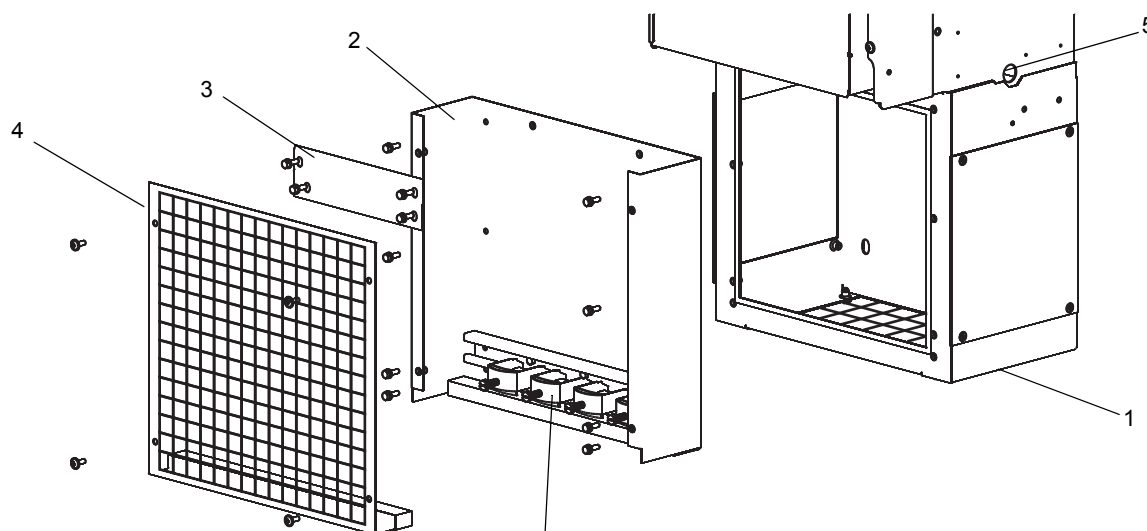

EMC clamp for holding the cables in place and connecting the shielding to ground

- Mount the chassis ① on the wall or the back of the enclosure under the drive. Ensure that the chassis is tightly secured to the drive to maintain the IP54 seal of the ventilation duct. To do this, slot the 2 locking flanges into the drive transport holes ⑤.
- Mount the EMC plate ② on the kit chassis using the screws provided.
- Mount the bridge ③ to ensure equipotentiality of the grounds between the drive and the EMC plate.
- Then mount the IP31 or NEMA type 1 cover ④ on the EMC plate using the screws provided.

### Note:

This kit can be used to simplify guiding the inlet air. It is supplied with a seal to provide IP54 sealing for the duct to the drive. Close the drive transport holes ⑤ with the plastic plugs provided.

# Installing the kit for IP31/NEMA type 1 conformity

VW3 A9 109 ... 116

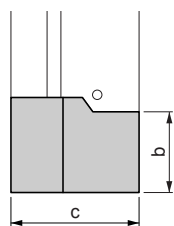

VW3 A9 109 ... 113, 115

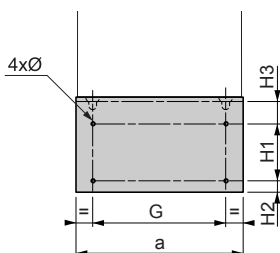

VW3 A9 114

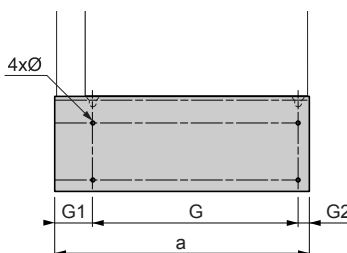

VW3 A9 116

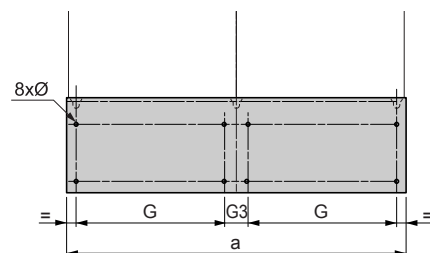

VW3	a mm (in.)	b mm (in.)	c mm (in.)	G mm (in.)	G1 mm (in.)	G2 mm (in.)	G3 mm (in.)	H1 mm (in.)	H2 mm (in.)	H3 mm (in.)	Ø mm (in.)	For screws
A9 109	325 (12.80)	228 (8.98)	375 (14.76)	250 (9.84)	- -	- -	- -	95 (3.74)	73 (2.87)	75 (2.95)	11.5 (0.45)	M10
A9 110	365 (14.37)	308 (12.13)	375 (14.76)	298 (11.73)	- -	- -	- -	250 (9.84)	35 (1.38)	35 (1.38)	11.5 (0.45)	M10
A9 111	345 (13.58)	323 (12.72)	362 (14.25)	285 (11.22)	- -	- -	- -	240 (9.40)	35 (1.38)	55 (2.15)	11.5 (0.45)	M10
A9 112	445 (17.52)	383 (15.08)	362 (14.25)	350 (13.78)	- -	- -	- -	250 (9.84)	65 (2.56)	75 (2.95)	11.5 (0.45)	M10
A9 113	600 (23.62)	383 (15.08)	362 (14.25)	540 (21.26)	- -	- -	- -	250 (9.84)	65 (2.56)	75 (2.95)	11.5 (0.45)	M10
A9 114	670 (23.43)	383 (15.08)	362 (14.25)	540 (21.26)	102.5 (4.03)	27.5 (1.08)	- -	250 (9.84)	65 (2.56)	75 (2.95)	11.5 (0.45)	M10
A9 115	895 (35.04)	483 (19.02)	462 (18.19)	835 (32.87)	- -	- -	- -	350 (13.78)	65 (2.56)	75 (2.95)	11.5 (0.45)	M10
A9 116	1125 (44.29)	483 (19.02)	462 (18.19)	495 (19.49)	- -	- -	75 (2.95)	350 (13.78)	65 (2.56)	75 (2.95)	11.5 (0.45)	M10

VW3 A9 209 ... 214

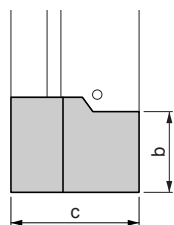

VW3 A9 209 ... 213

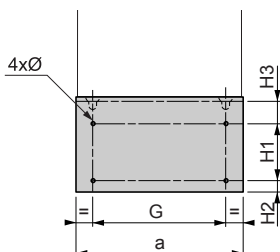

VW3 A9 214

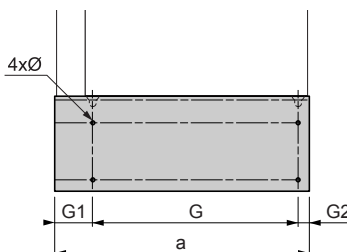

VW3	a mm (in.)	b mm (in.)	c mm (in.)	G mm (in.)	G1 mm (in.)	G2 mm (in.)	G3 mm (in.)	H1 mm (in.)	H2 mm (in.)	H3 mm (in.)	Ø mm (in.)	For screws
A9 209	325 (12.80)	228 (8.98)	375 (14.76)	250 (9.84)	- -	- -	- -	95 (3.74)	73 (2.87)	75 (2.95)	11.5 (0.45)	M10
A9 210	365 (14.37)	308 (12.13)	375 (14.76)	298 (11.73)	- -	- -	- -	250 (9.84)	35 (1.38)	35 (1.38)	11.5 (0.45)	M10
A9 211	345 (13.58)	323 (12.72)	375 (14.76)	285 (11.22)	- -	- -	- -	240 (9.40)	35 (1.37)	55 (2.15)	11.5 (0.45)	M10
A9 212	445 (17.52)	383 (15.08)	429 (16.89)	350 (13.78)	- -	- -	- -	250 (9.84)	65 (2.56)	75 (2.95)	11.5 (0.45)	M10
A9 213	600 (23.62)	383 (15.08)	475 (18.70)	540 (21.26)	- -	- -	- -	250 (9.84)	65 (2.56)	75 (2.95)	11.5 (0.45)	M10
A9 214	670 (23.43)	383 (15.08)	475 (18.70)	540 (21.26)	102.5 (4.03)	27.5 (1.08)	- -	250 (9.84)	65 (2.56)	75 (2.95)	11.5 (0.45)	M10

## Position of the charging LED

---

Before working on the drive, switch it off, wait until the red capacitor charging LED has gone out, then measure the DC bus voltage.

### Position of the capacitor charging LED

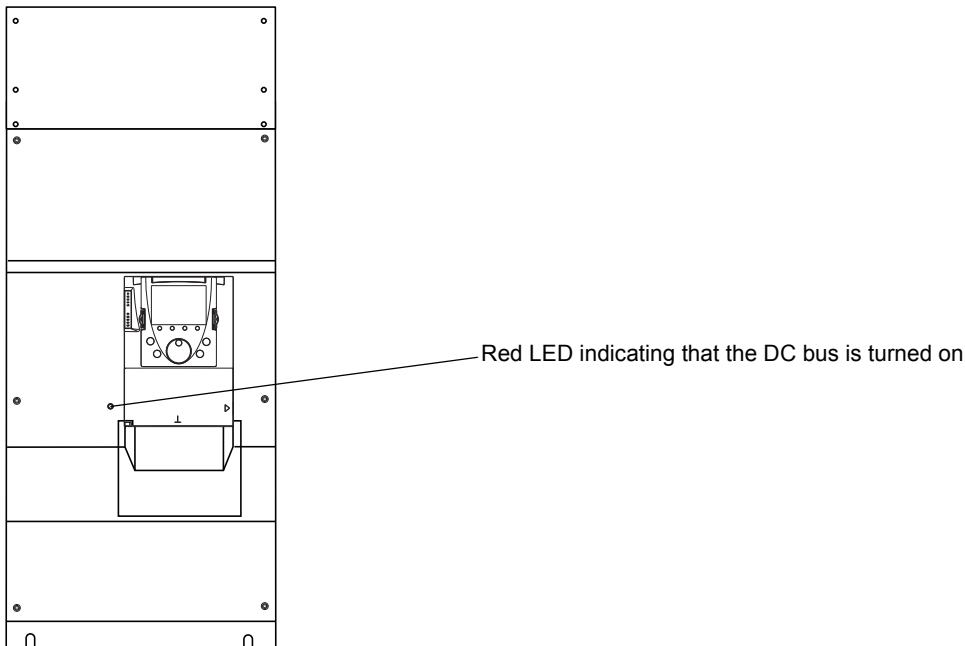

### Procedure for measuring the DC voltage

<b>⚠ DANGER</b>
<b>HAZARDOUS VOLTAGE</b> Read and understand the instructions on page <a href="#">5</a> before performing this procedure. <b>Failure to follow this instruction will result in death or serious injury.</b>

The DC bus voltage can exceed 1,000 V  $\text{---}$ . Use a properly rated voltage sensing device when performing this procedure. To measure the DC bus voltage:

- 1 Disconnect the drive power supply.
- 2 Wait for the capacitor charging LED to go off.
- 3 Measure the voltage of the DC bus between the PA/+ and PC/- terminals to check whether the voltage is less than 45 V  $\text{---}$ . Please refer to page [35](#) for the arrangement of the power terminals.
- 4 If the DC bus capacitors have not discharged completely, contact your local Schneider Electric representative (do not repair or operate the drive).

# Installing option cards

These should ideally be installed after mounting the drive and before wiring it.

Check that the red capacitor charging LED has gone out. Measure the DC bus voltage in accordance with the procedure described on page [30](#).

The option cards are installed under the drive control front panel. Remove the graphic display terminal then take off the control front panel as shown below.

## Removing the control front panel

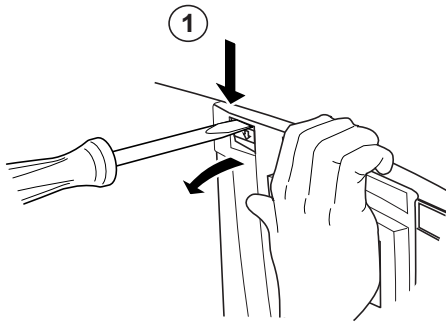

- Using a screwdriver, press down on the catch and pull to release the left-hand part of the control front panel

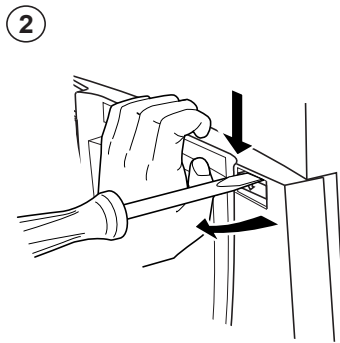

- Do the same on the right-hand side

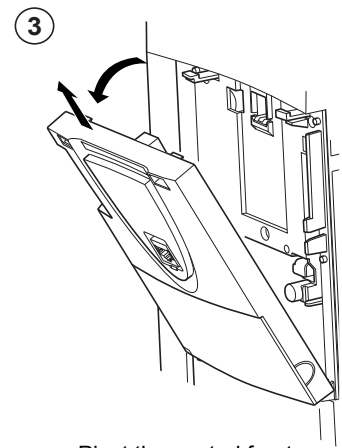

- Pivot the control front panel and remove it

## Removing the empty option card support

ⓘ ATV71H D55M3X to D75M3X, ATV71H D90N4 to C50N4 and ATV71H C11Y to C63Y drives are supplied with empty an option card support already installed. If adding an I/O or communication option card or a "Controller Inside" programmable card, remove the support following the procedure described below. This card support serves no purpose when at least one option card is used.

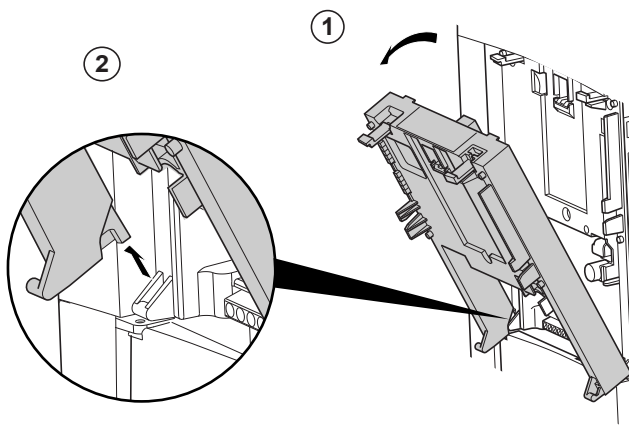

- ① Open the empty option card support
- ② Unhook the support from its clasps and remove it

# Installing option cards

## Installing an encoder interface card

There is a special slot on the drive for adding an encoder interface card.

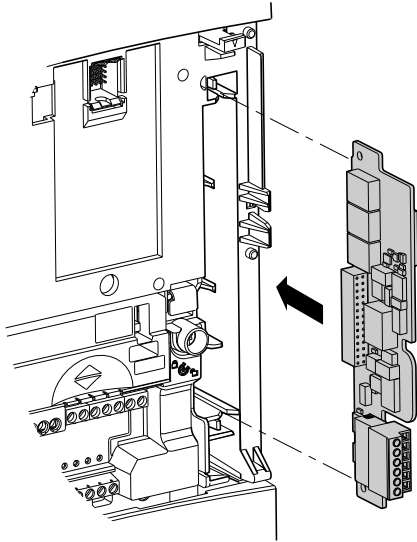

- First remove the empty option card support (if present), as described on the previous page, so you can access the slot for the encoder feedback card.
- If an I/O or communication option card or a "Controller Inside" programmable card has already been installed, remove it so you can access the slot for the encoder feedback card.
- Once you have installed the encoder interface card, replace the empty card support or any option cards.

## Installing an I/O extension card, a communication card or a "Controller Inside" programmable card

### CAUTION

#### RISK OF DAMAGE TO THE CONNECTOR

Ensure good positioning of the option card on the clasps to avoid damage to the connector.

Failure to follow these instructions can result in equipment damage.

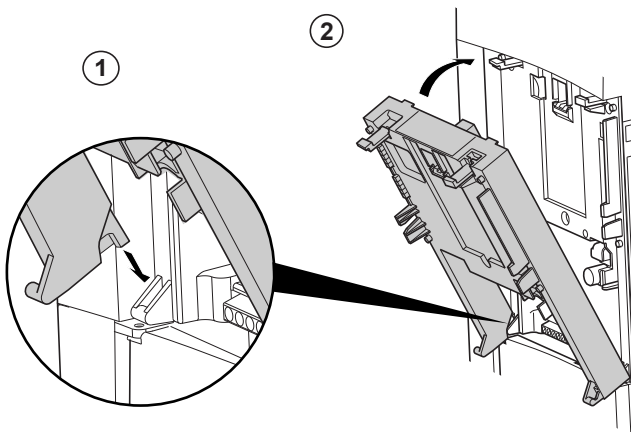

- ① Position the option card on the clasps
- ② Pivot the card until it clicks into place

## Replacing the control front panel

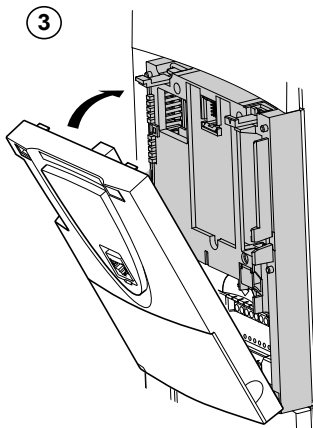

- ③ Replace the control front panel on the option card (same procedure as for installing the option card, see ① and ②)



# Wiring recommendations

## Power

The drive must be connected to the protective ground. To comply with current regulations concerning high leakage currents (above 3.5 mA), use at least a 10 mm<sup>2</sup> (AWG 6) protective conductor or 2 protective conductors with the same cross-section as the power section AC supply conductors.

### DANGER

#### HAZARDOUS VOLTAGE

Ground equipment using the ground connecting point provided as illustrated. The drive panel must be properly grounded before power is applied.

**Failure to follow these instructions will result in death or serious injury.**

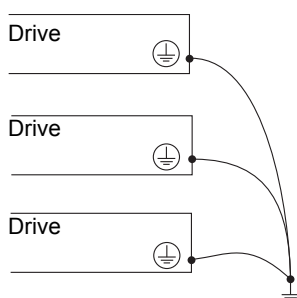

- Check whether the resistance to the protective ground is one ohm or less.
- If several drives need to be connected to the protective ground, each one must be connected directly to this ground as illustrated opposite.

### WARNING

#### IMPROPER WIRING PRACTICES

- Applying input line voltage to the output terminals (U/T1,V/T2,W/T3) will damage the ATV71.
- Check the power connections before powering up the ATV71 drive.
- If replacing another drive, verify that all wiring connections to the ATV71 drive comply with all wiring instructions in this manual.

**Failure to follow these instructions can result in death, serious injury or equipment damage.**

When upstream protection by means of a "residual current device" is required by installation standards, a type A device should be used for single-phase drives and type B for three-phase drives. Choose a suitable model integrating:

- HF current filtering
- A time delay which prevents tripping caused by the load from stray capacitance on power-up. A time delay is not possible for 30 mA devices. In this case, choose devices with immunity against nuisance tripping, for example, "residual current devices" with reinforced immunity from the s.i range (Merlin Gerin brand).

If the installation includes several drives, provide one "residual current device" per drive.

### WARNING

#### INADEQUATE OVERCURRENT PROTECTION

- Overcurrent protective devices must be properly coordinated.
- The Canadian Electricity Code and the National Electrical Code require branch circuit protection. Use the fuses recommended on the drive nameplate to achieve published short-circuit current ratings.
- Do not connect the drive to a line supply whose short-circuit capacity exceeds the maximum prospective short-circuit current listed in the tables on pages [11](#), [12](#) and [13](#).

**Failure to follow these instructions can result in death, serious injury or equipment damage.**

# Wiring recommendations

Keep the power cables separate from circuits in the installation with low-level signals (sensors, PLCs, measuring apparatus, video, telephone).

The motor cables must be at least 0.5 m (20 in.) long.

In certain applications involving the immersion of the cables in water, the earth leakage currents can cause tripping, making the addition of output filters necessary.

Do not use surge arresters or power factor correction capacitors on the variable speed drive output.

 <b>CAUTION</b>
<b>IMPROPER USE OF A BRAKING RESISTOR</b>
<ul style="list-style-type: none"> <li>• Only use the braking resistance values recommended in our catalogs.</li> <li>• Wire a thermal overload relay in the sequence or configure the braking resistor protection (please refer to the Programming Manual) so that the drive power section AC supply is disconnected in the event of a fault.</li> </ul>
<b>Failure to follow these instructions can result in injury and/or equipment damage.</b>

## Control

Keep the control circuits away from the power circuits. For control and speed reference circuits, we recommend using shielded twisted cables with a pitch of between 25 and 50 mm (0.98 and 1.97 in.) and connecting the shielding to ground at each end.

If using conduit, do not lay the motor, power supply and control cables in the same conduit. Keep the metal conduit containing the power supply cables at least 8 cm (3 in.) away from the metal conduit containing the control cables. Keep the non-metal conduits or cable ducts containing the power supply cables at least 31 cm (12 in.) away from the metal conduits containing the control cables. If it is necessary for control and power cables to cross each other, be sure they cross at right angles.

## Length of motor cables

		0 (0 ft)	15 m (49.2 ft)	30 m (98.4 ft)	100 m (328 ft)	200 m (656 ft)	300 m (984 ft)	400 m (1,312 ft)	600 m (1,968 ft)
ATV71H●●●M3X ATV71H D90N4 to C50N4	Shielded cable				Motor choke	2 motor chokes in series			
	Unshielded cable				Motor choke	2 motor chokes in series			
ATV71H C11Y to C63Y	Shielded cable	Please refer to the catalog							
	Unshielded cable	Please refer to the catalog							

**Note:** On old-generation motors or those with poor insulation we recommend using a motor choke where the cable is more than 5 m (16.4 ft) long.

### Choice of associated components:

Please refer to the catalog.

# Power terminals

## Accessing the power terminals on ATV71H●●●M3X and ATV71H●●●N4 drives

To access the power terminals, unscrew the front panel and remove the protective cover.

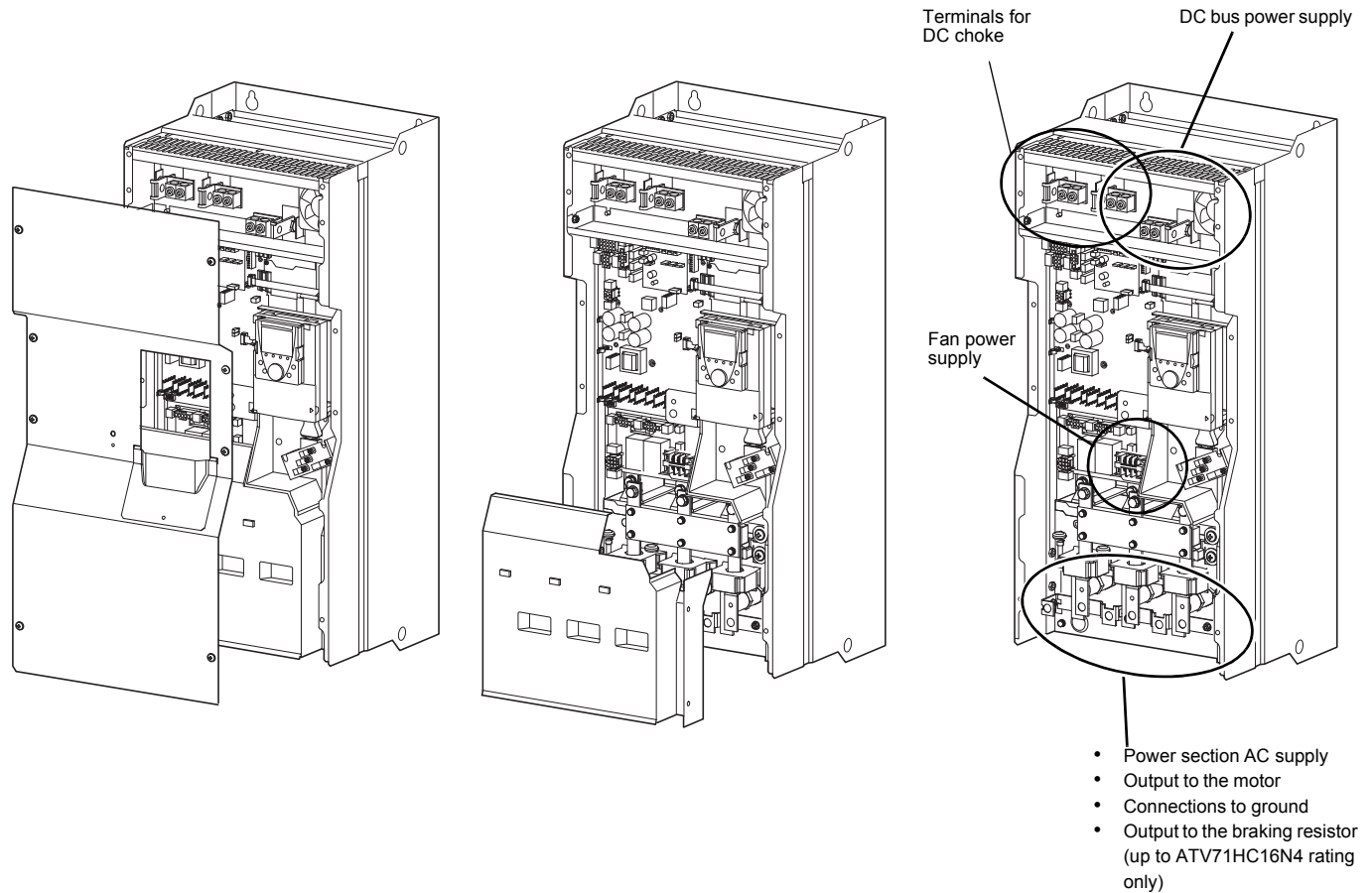

## Characteristics and functions of the power terminals

Terminals	Function	Altivar
3 x $\perp$	Protective ground connection terminals	All ratings
R/L1, S/L2, T/L3 (1)	Power section AC supply	All ratings
PO	DC choke connection	ATV71H D55M3X, D75M3X ATV71H D90N4 to C28N4
PO.1, PO.2	DC choke connection	ATV71H C31N4 to C50N4
PA/+	DC bus + polarity and DC choke connection	All ratings
PC/-	DC bus - polarity	All ratings
PA	Output to the braking resistor	ATV71H D55M3X, D75M3X ATV71H D90N4 to C16N4 (2)
PB	Output to the braking resistor	
U/T1, V/T2, W/T3	Output to the motor	All ratings
RO, SO, TO	Separate fan power supply when the drive is powered only by the DC bus	ATV71H D75M3X ATV71H C11N4 to C50N4
BU+, BU-	+ and - polarities to be connected to the braking unit	ATV71H C20N4 to C50N4
X20, X92, X3	Braking unit control cable connection	Please refer to the User's Manual for the braking unit.

(1) The ATV71H C40N4 and C50N4 have two input bridges. The power section AC supply is connected on terminals R/L1.1 - R/L1.2, S/L2.1 - S/L2.2 and T/L3.1 - T/L3.2.

(2) From the ATV71HC20N4 upwards, there are no braking resistor connection terminals on the drive as the braking unit is optional (please refer to the catalog). The braking resistor is connected on the braking unit.

# Power terminals

## Accessing the power terminals on ATV71H●●●Y drives

To access the power terminals, unscrew the front panel and remove the protective cover.

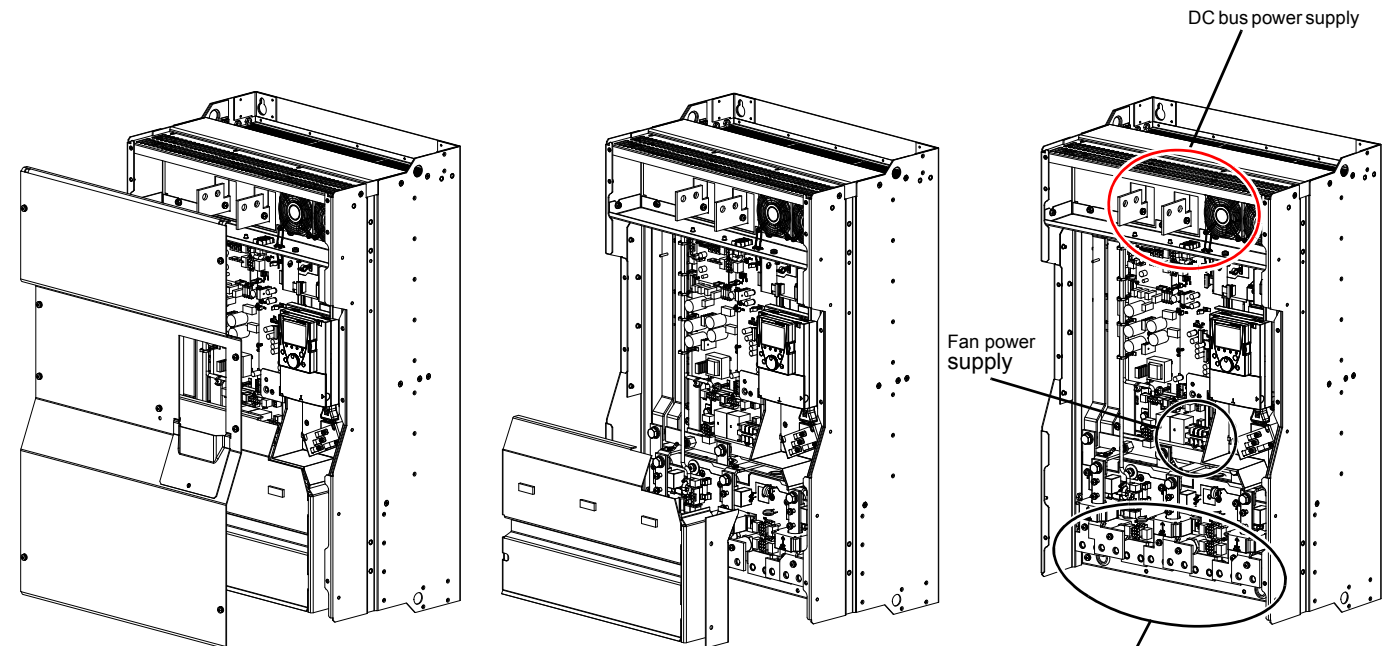

View from below

- Power section AC supply
- Output to the motor
- Connections to ground
- Output to the braking resistor (up to ATV71HC16Y rating only)

## Characteristics and functions of the power terminals

Terminals	Function	Altivar
3 x $\perp$	Protective ground connection terminals	All ratings
R/L1, S/L2, T/L3 (1)	Power section AC supply	All ratings
PA/+	DC bus + polarity	All ratings
PC/-	DC bus - polarity	All ratings
PA	Output to the braking resistor	ATV71H C11Y to C16Y (2)
PB	Output to the braking resistor	
U/T1, V/T2, W/T3	Output to the motor	All ratings
RO, SO, TO	Separate fan power supply when the drive is powered only by the DC bus	ATV71H C11Y to C63Y
BU+, BU-	+ and - polarities to be connected to the braking unit	ATV71H C20Y to C63Y
X20, X92, X3	Braking unit control cable connection	Please refer to the User's Manual for the braking unit.

(1) ATV61H C40Y to C63Y drives have two input bridges. The power section AC supply is connected on terminals R/L1.1 - R/L1.2, S/L2.1 - S/L2.2 and T/L3.1 - T/L3.2.

(2) From the ATV71HC20Y onwards, there are no braking resistor connection terminals on the drive as the braking unit is optional (please refer to the catalog). The braking resistor is connected on the braking unit.

# Power terminals

## ATV71H D55M3X, D90N4

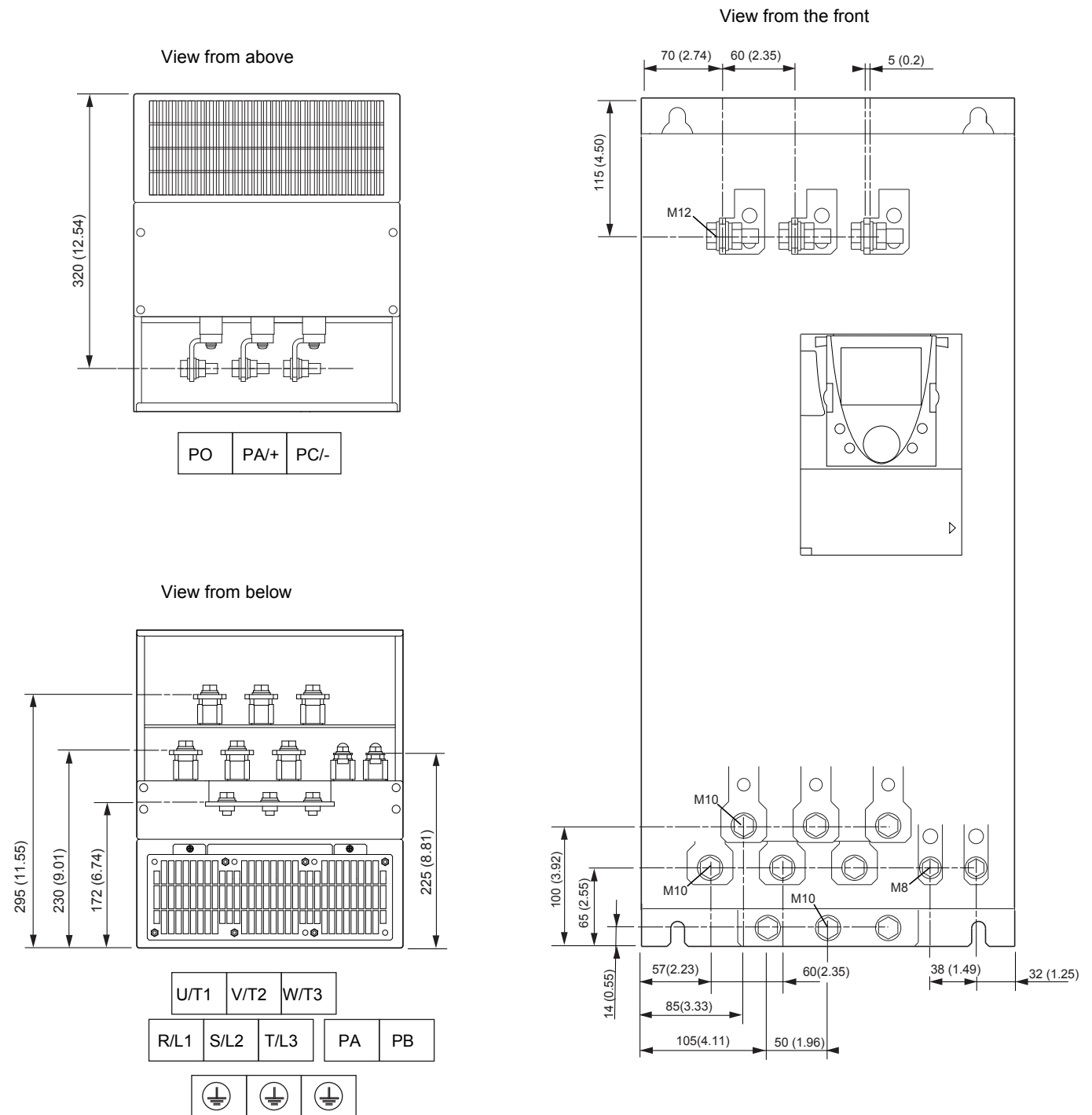

### Maximum terminal wire size/tightening torque

Drive terminals	L1/R, L2/S, L3/T, U/T1, V/T2, W/T3	PC/-, PO, PA/+	PA, PB
	2 x 100 mm <sup>2</sup> /24 Nm	2 x 100 mm <sup>2</sup> /41Nm	60 mm <sup>2</sup> /12 Nm
	2 x 250 MCM/212 lb.in	2 x 250 MCM/360 lb.in	250 MCM/106 lb.in

# Power terminals

## ATV71H D75M3X, C11N4

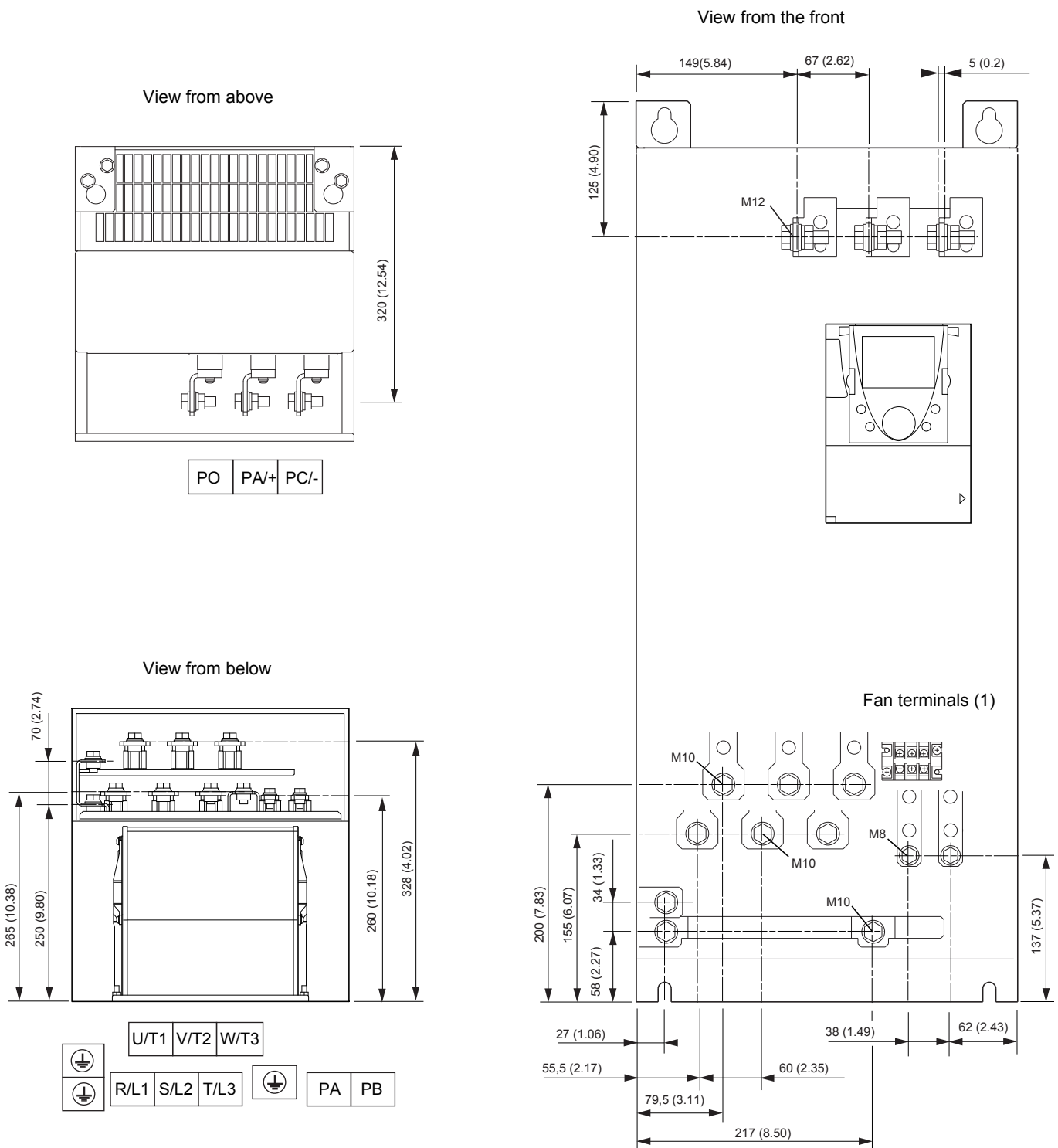

### Maximum terminal wire size/tightening torque

Drive terminals	L1/R, L2/S, L3/T, U/T1, V/T2, W/T3	PC/-, PO, PA/+	PA, PB	RO, SO, TO (1)
	2 x 100 mm <sup>2</sup> /24Nm	2 x 150 mm <sup>2</sup> /41 Nm	60 mm <sup>2</sup> /12 Nm	5.5 mm <sup>2</sup> /1.4 Nm
	2 x 250 MCM/212 lb.in	2 x 250 MCM/360 lb.in	250 MCM/106 lb.in	AWG 10/12 lb.in

(1) Fan power supply, compulsory if the drive is powered only by the DC bus. Do not use if the drive is powered with a three-phase supply by L1/R, L2/S, L3/T.

# Power terminals

## ATV71HC13N4

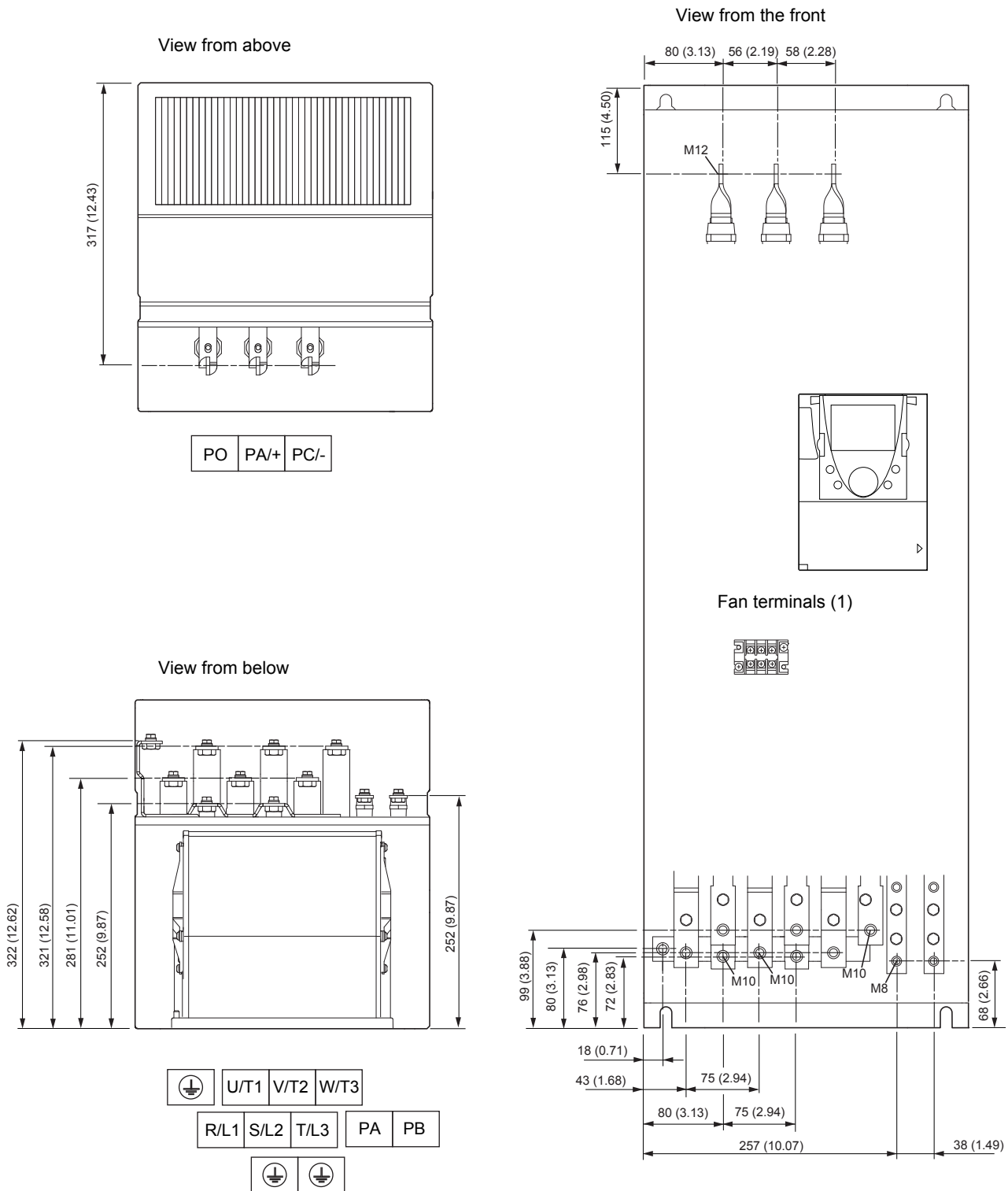

### Maximum terminal wire size/tightening torque

Drive terminals	L1/R, L2/S, L3/T, U/T1, V/T2, W/T3	PC-, PO, PA+	PA, PB	RO, SO, TO (1)
	2 x 120 mm <sup>2</sup> /24 Nm	2 x 120 mm <sup>2</sup> /24 Nm	120 mm <sup>2</sup> /24 Nm	5.5 mm <sup>2</sup> /1.4 Nm
	2 x 250 MCM/212 lb.in	2 x 250 MCM/212 lb.in	250 MCM/212 lb.in	AWG 10/12 lb.in

(1) Fan power supply, compulsory if the drive is powered only by the DC bus. Do not use if the drive is powered with a three-phase supply by L1/R, L2/S, L3/T.

# Power terminals

## ATV71HC16N4

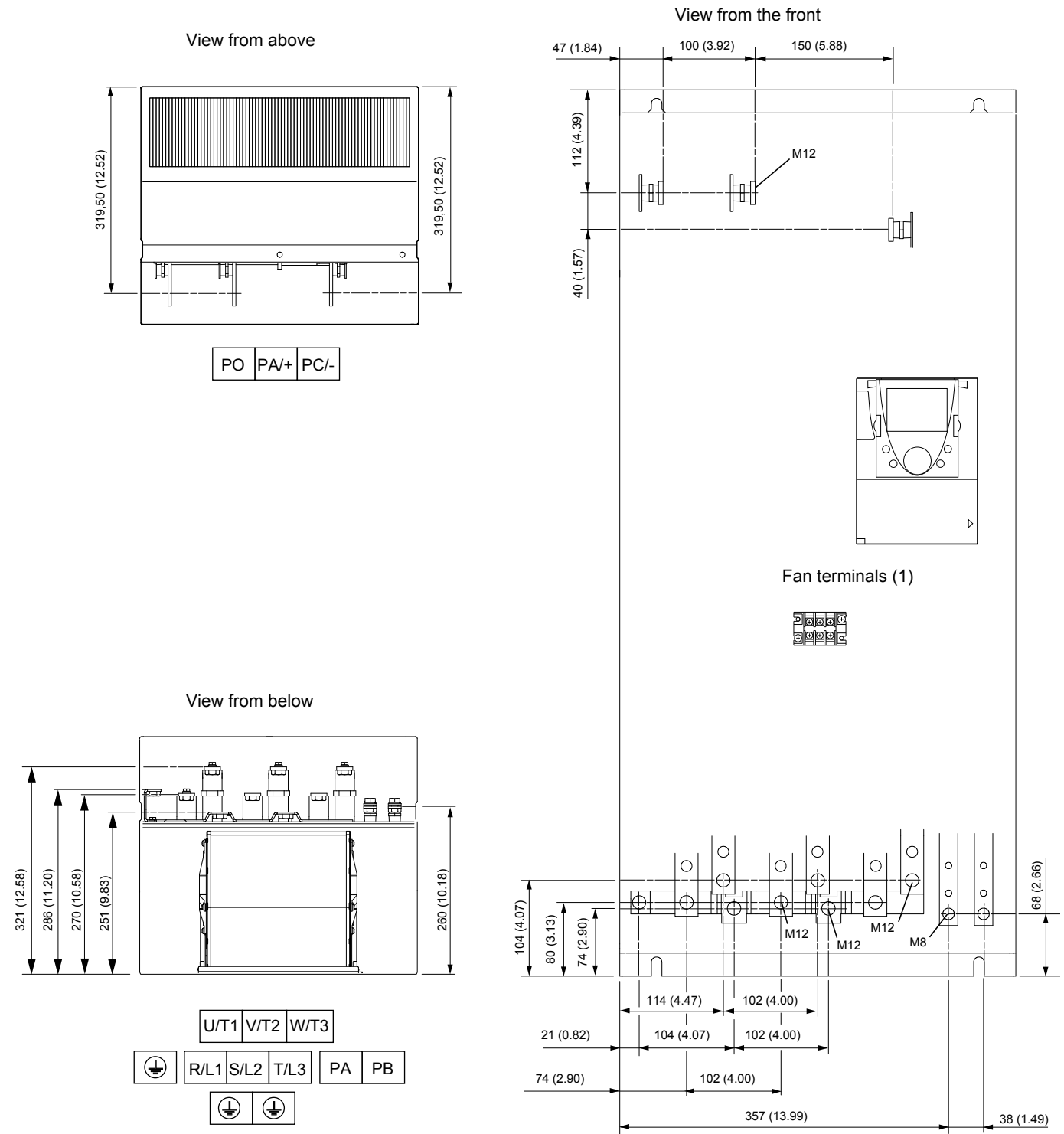

### Maximum terminal wire size/tightening torque

Drive terminals	L1/R, L2/S, L3/T, U/T1, V/T2, W/T3	PC/-, PO, PA/+	PA, PB	RO, SO, TO (1)
	2 x 150 mm <sup>2</sup> /41 Nm	2 x 150 mm <sup>2</sup> /41 Nm	120 mm <sup>2</sup> /24 Nm	5.5 mm <sup>2</sup> /1.4 Nm
	2 x 350 MCM/360 lb.in	2 x 350 MCM/360 lb.in	250 MCM/212 lb.in	AWG 10/12 lb.in

(1) Fan power supply, compulsory if the drive is powered only by the DC bus. Do not use if the drive is powered with a three-phase supply by L1/R, L2/S, L3/T.



# Power terminals

## ATV71H C20N4, C25N4, C28N4

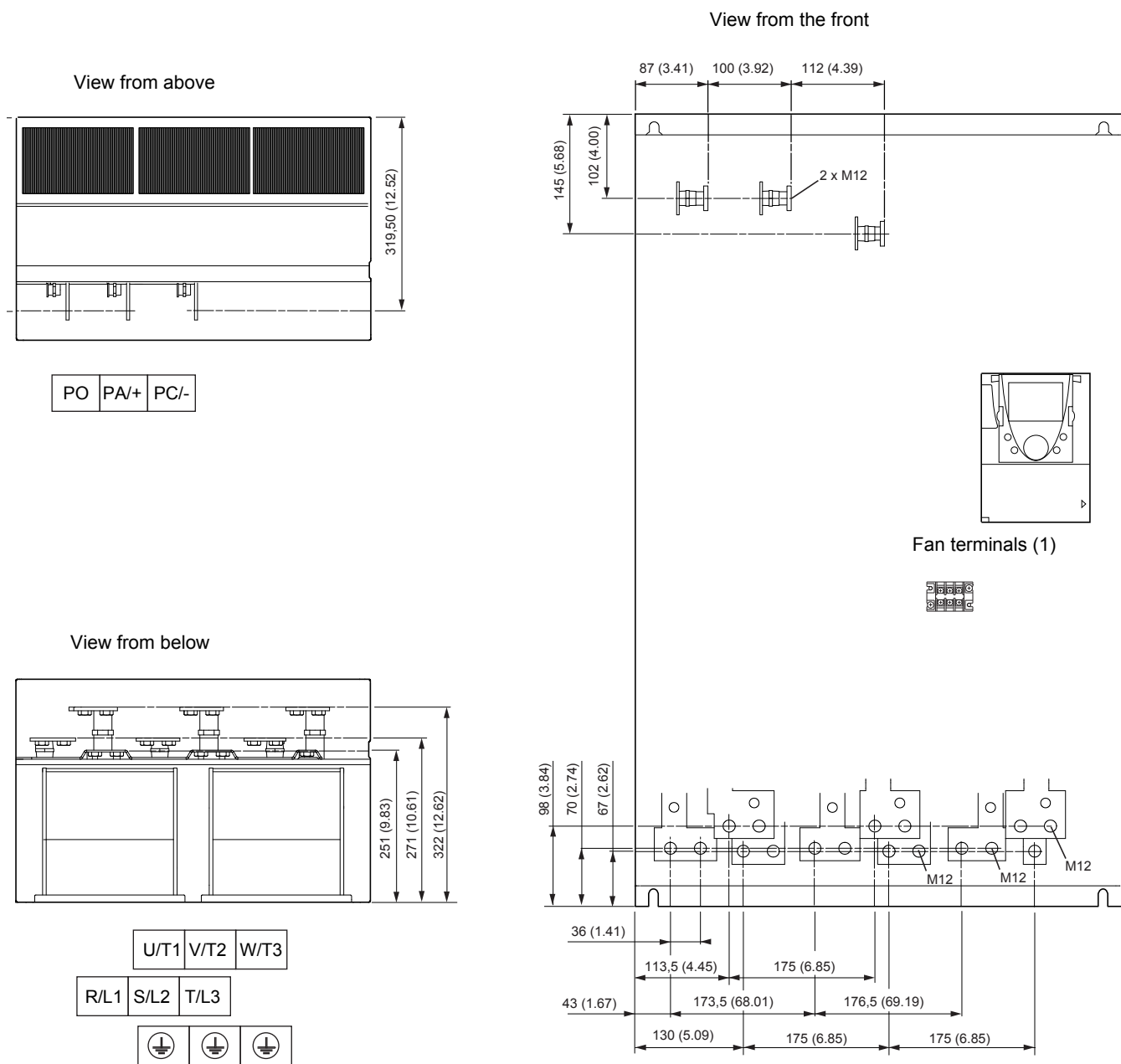

### Maximum terminal wire size/tightening torque

Drive terminals	L1/R, L2/S, L3/T, U/T1, V/T2, W/T3	PC/-, PO, PA/+	RO, SO, TO (1)
	4 x 185 mm <sup>2</sup> /41 Nm	4 x 185 mm <sup>2</sup> /41 Nm	5.5 mm <sup>2</sup> /1.4 Nm
	3 x 350 MCM/360 lb.in	3 x 350 MCM/360 lb.in	AWG 10/12 lb.in

(1) Fan power supply, compulsory if the drive is powered only by the DC bus. Do not use if the drive is powered with a three-phase supply by L1/R, L2/S, L3/T.

# Power terminals

## ATV71HC31N4

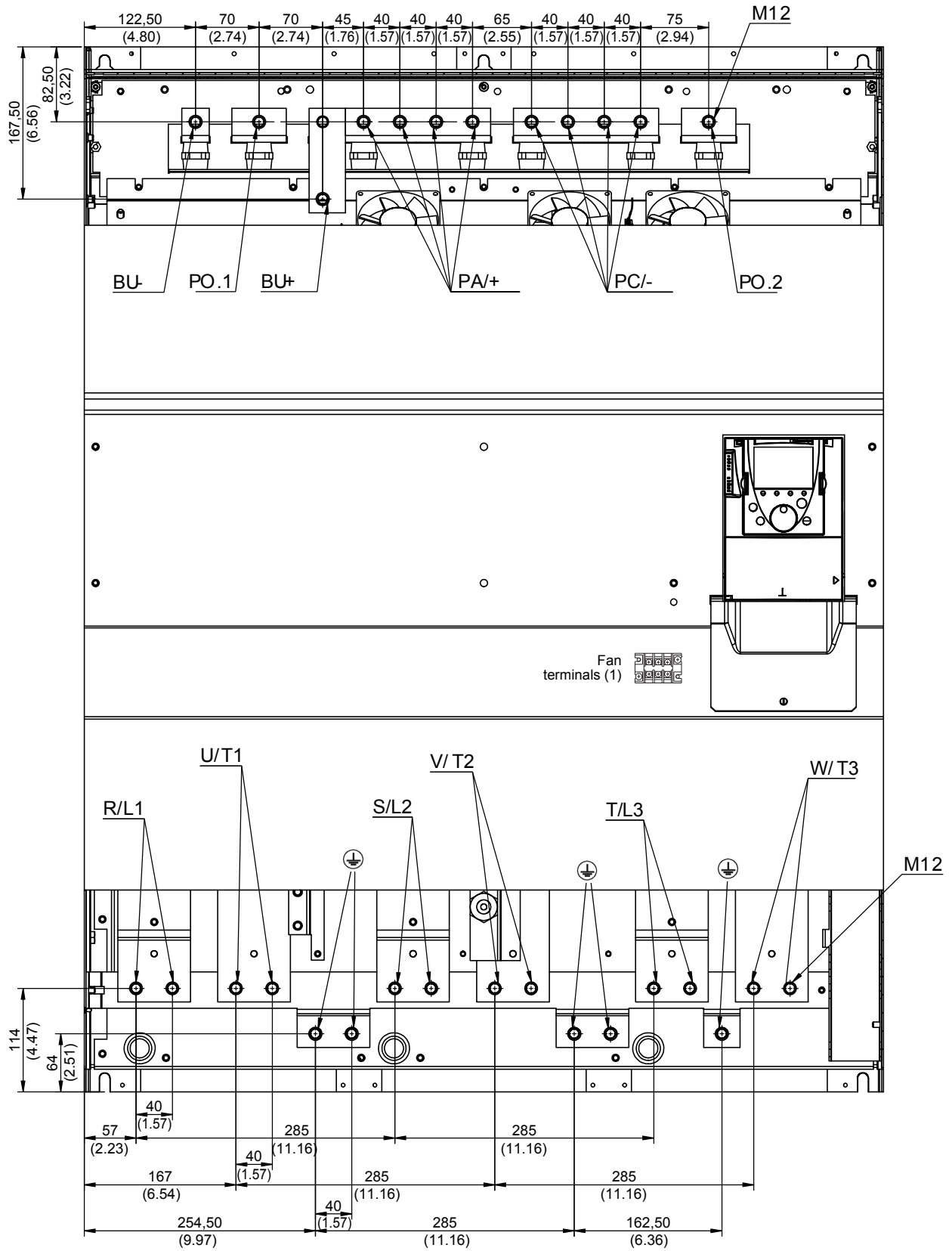

# Power terminals

## ATV71HC31N4

View from above

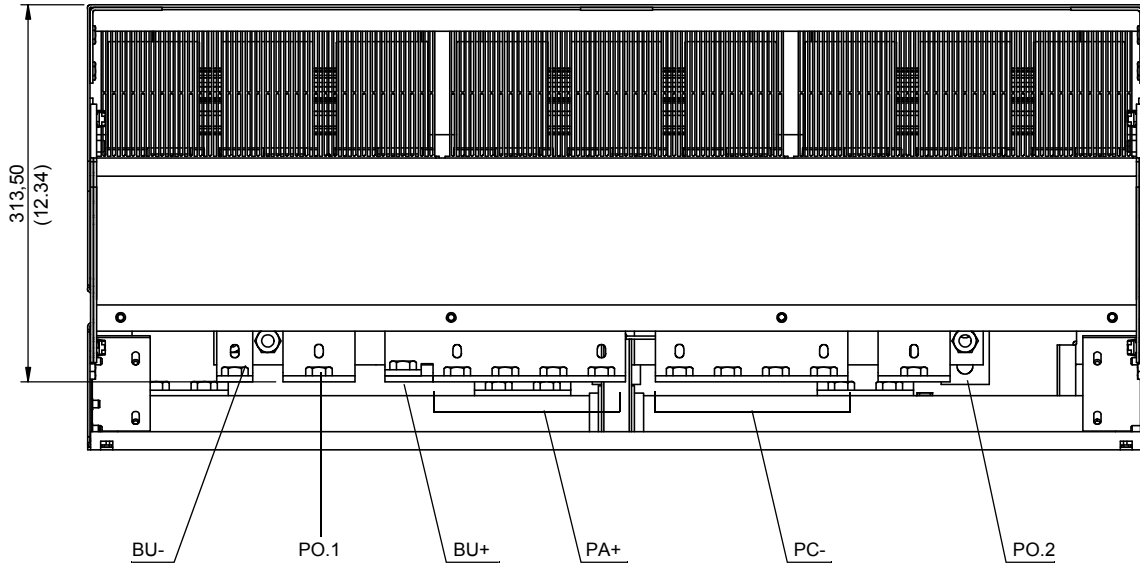

View from below

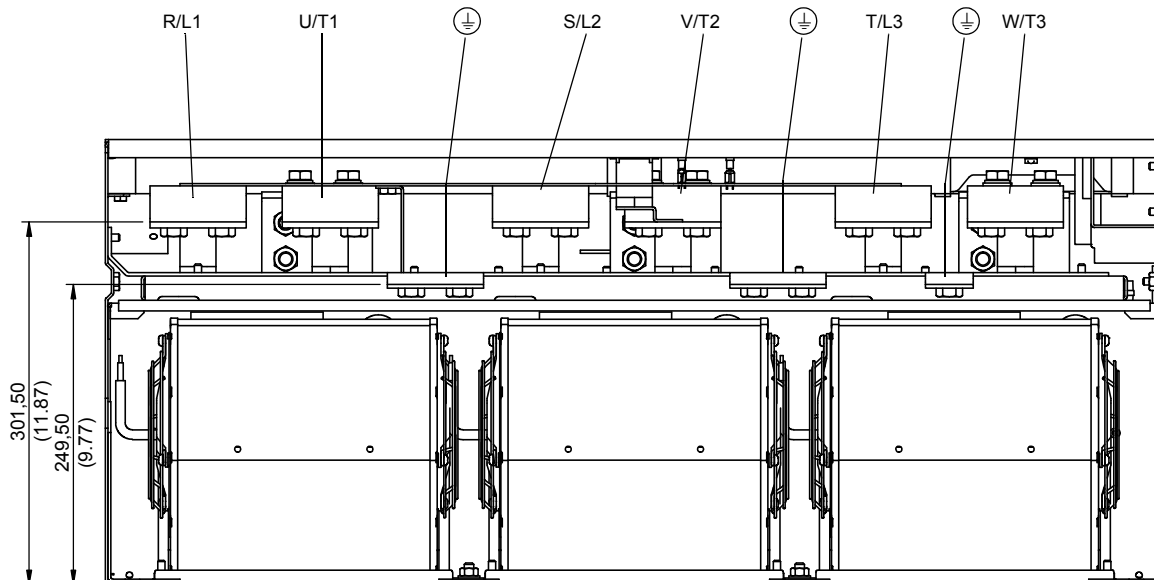

### Maximum terminal wire size/tightening torque

Drive terminals	L1/R, L2/S, L3/T, U/T1, V/T2, W/T3	PC/-, PA/+	RO, SO, TO (1)
ATV 71HC31N4	4 x 185 mm <sup>2</sup> /41 Nm	8 x 185 mm <sup>2</sup> /41 Nm	5.5 mm <sup>2</sup> /1.4 Nm
	4 x 500 MCM/360 lb.in	4 x 500 MCM/360 lb. in	AWG 10/12 lb. in

(1) Fan power supply, compulsory if the drive is powered only by the DC bus. Do not use if the drive is powered with a three-phase supply by L1/R, L2/S, L3/T.

# Power terminals

ATV71HC40N4

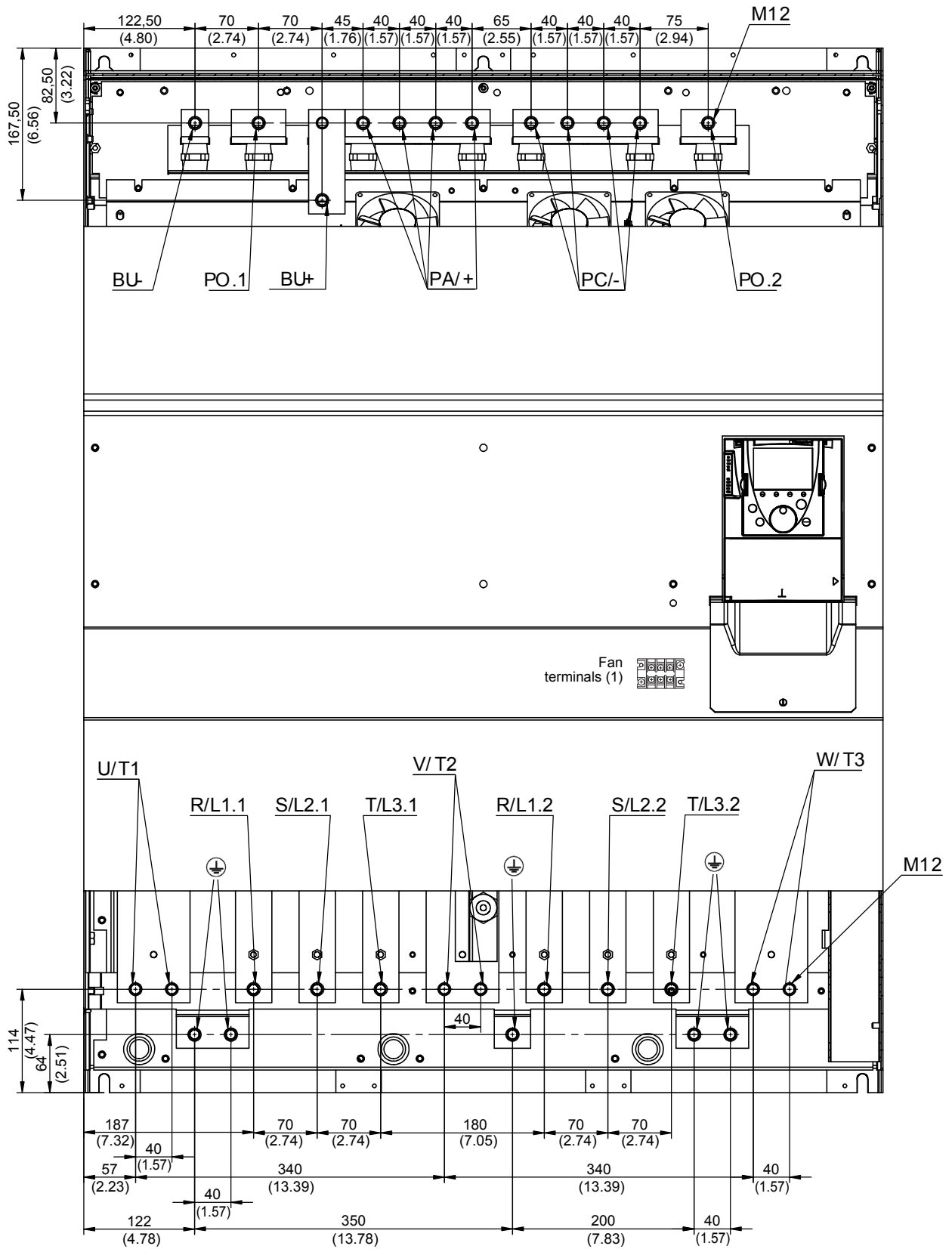

# Power terminals

## ATV71HC40N4

View from above

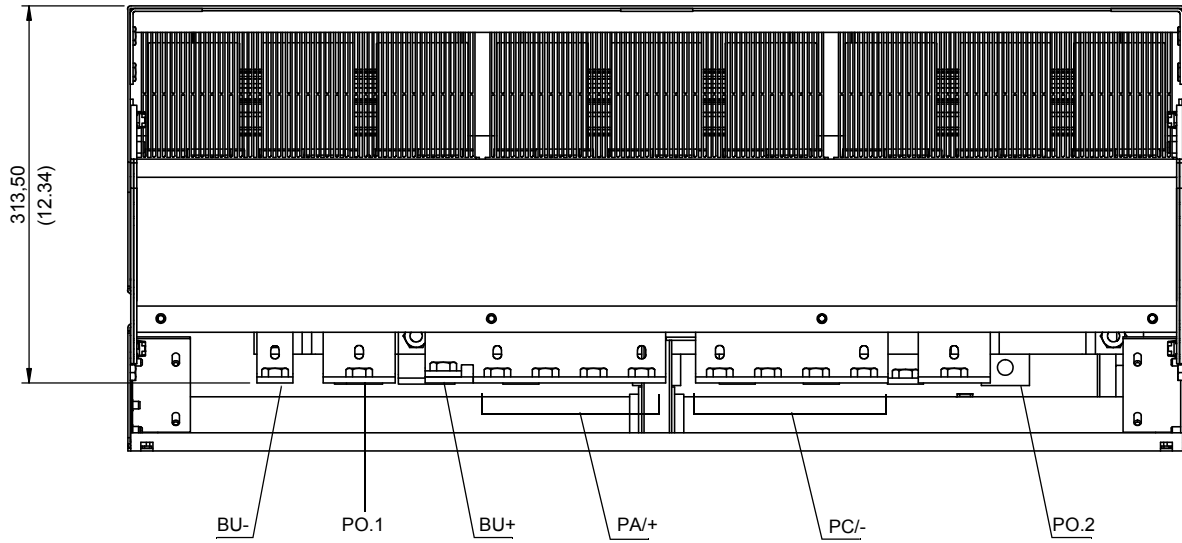

View from below

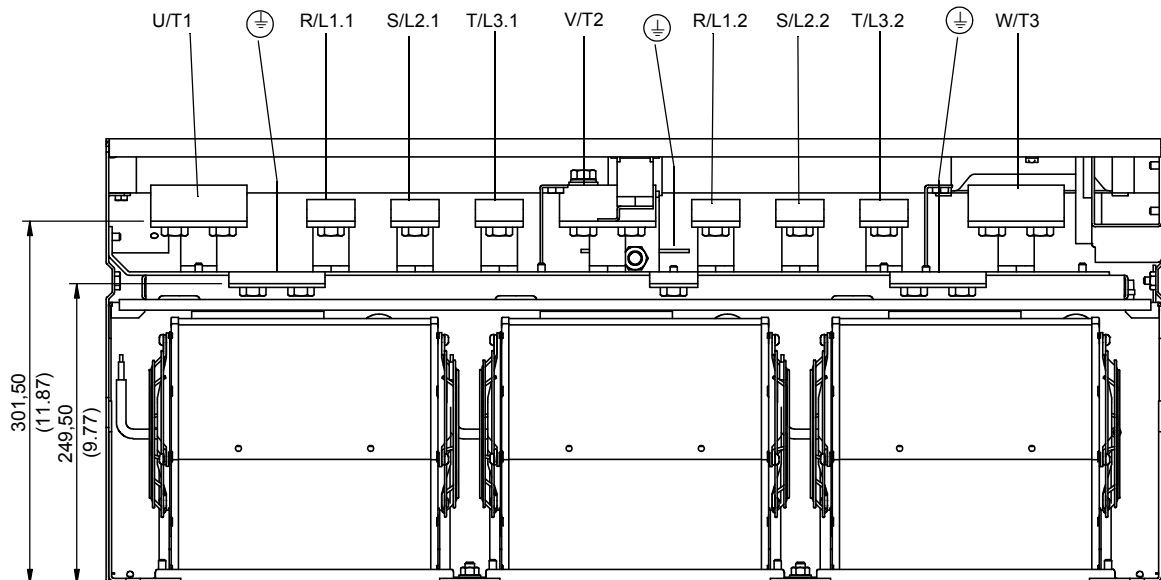

### Maximum terminal wire size/tightening torque

Drive terminals	R/L1.1, R/L1.2, S/L2.1, S/L2.2, T/L3.1, T/L3.2	U/T1, V/T2, W/T3	PC/-, PA/+	RO, SO, TO (1)
ATV 71HC40N4	2 x 185 mm <sup>2</sup> /41 Nm	4 x 185 mm <sup>2</sup> /41 Nm	8 x 185 mm <sup>2</sup> /41 Nm	5.5 mm <sup>2</sup> /1.4 Nm
	2 x 500 MCM/360 lb.in	4 x 500 MCM/360 lb.in	4 x 500 MCM/360 lb.in	AWG 10/12 lb.in

(1) Fan power supply, compulsory if the drive is powered only by the DC bus. Do not use if the drive is powered with a three-phase supply by L1/R, L2/S, L3/T.

# Power terminals

## ATV71HC50N4

View from the front

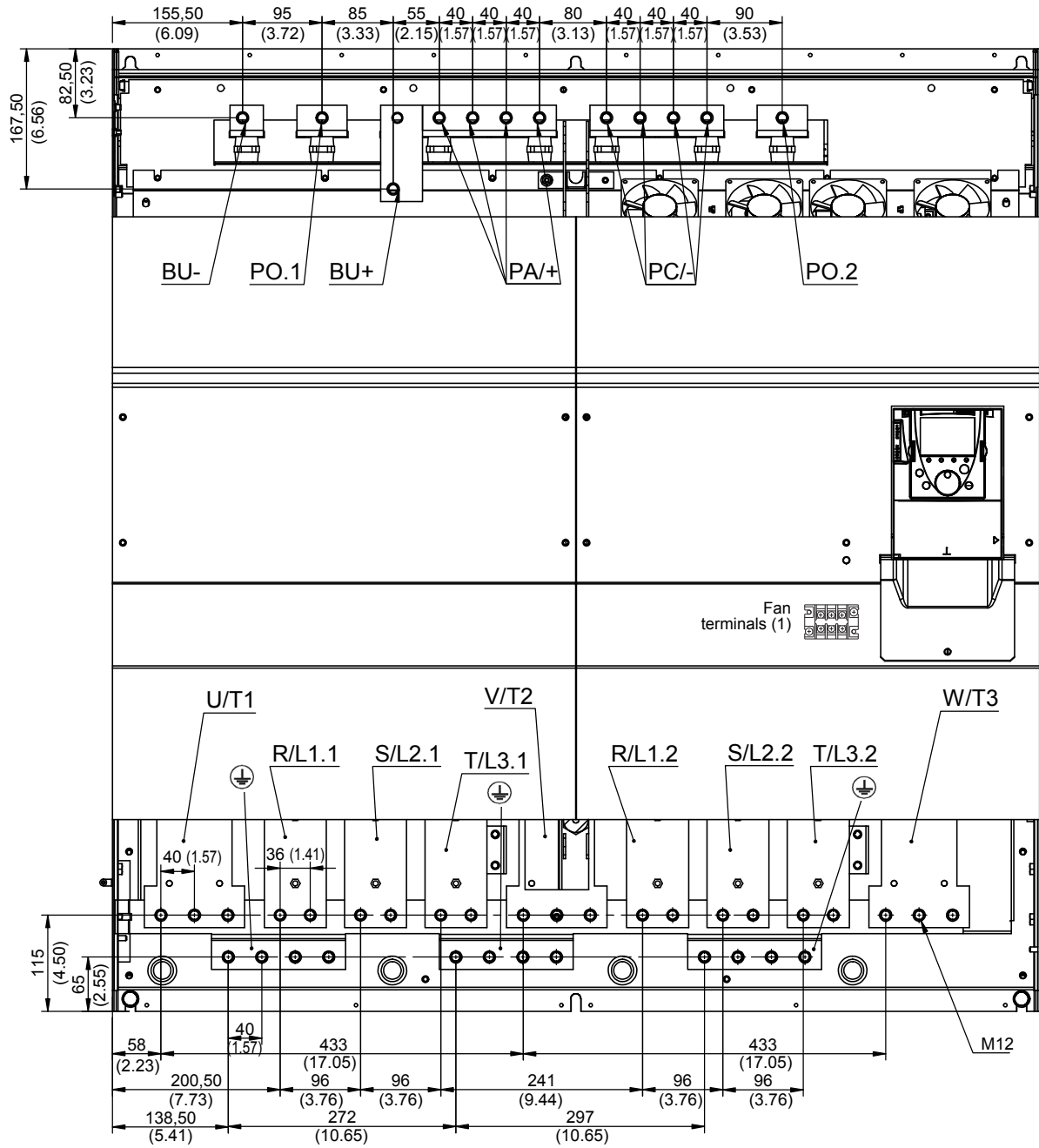

# Power terminals

## ATV71HC50N4

View from above

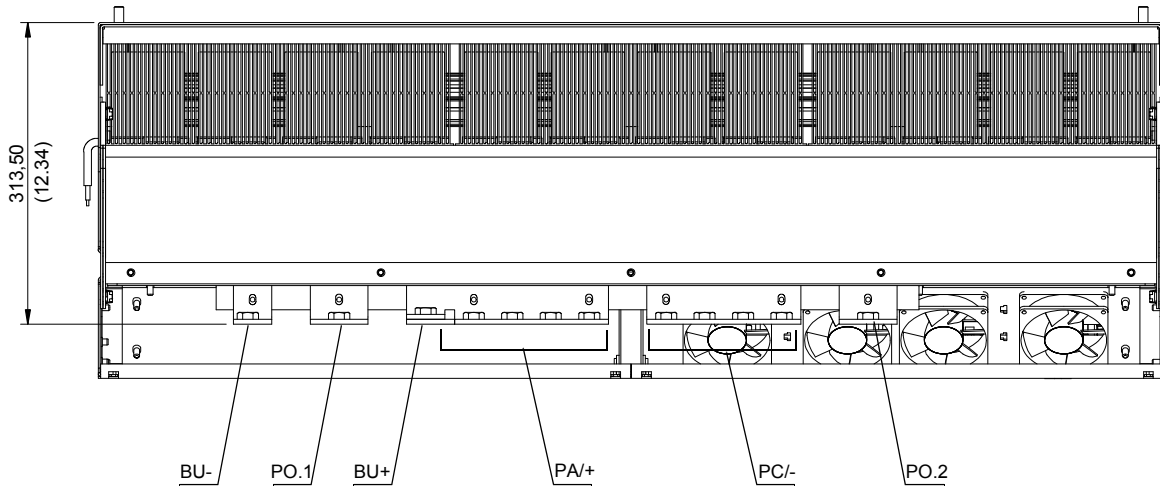

View from below

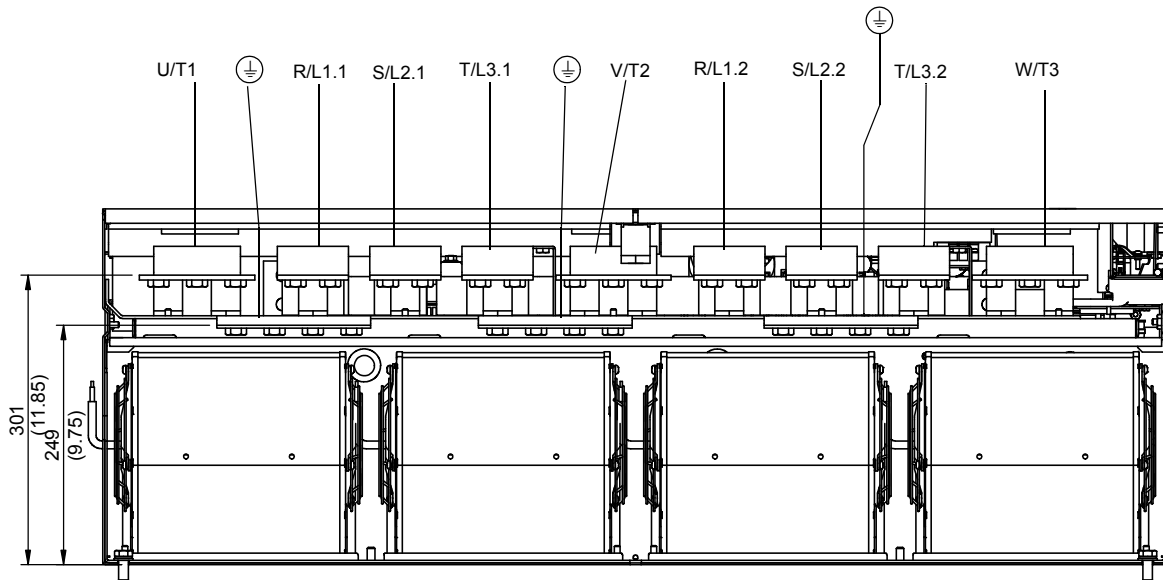

### Maximum terminal wire size/tightening torque

Drive terminals	R/L1.1, R/L1.2, S/L2.1, S/L2.2, T/L3.1, T/L3.2	U/T1, V/T2, W/T3	PC-, PA+	RO, SO, TO (1)
ATV 71HC50N4	4 x 185 mm <sup>2</sup> /41 Nm	6 x 185 mm <sup>2</sup> /41 Nm	8 x 185 mm <sup>2</sup> /41 Nm	5.5 mm <sup>2</sup> /1.4 Nm
	3 x 500 MCM/360 lb.in	5 x 500 MCM/360 lb.in	5 x 500 MCM/360 lb.in	AWG 10/12 lb.in

(1) Fan power supply, compulsory if the drive is powered only by the DC bus. Do not use if the drive is powered with a three-phase supply by L1/R, L2/S, L3/T.

# Power terminals

## ATV71H C11Y, 13Y, 16Y

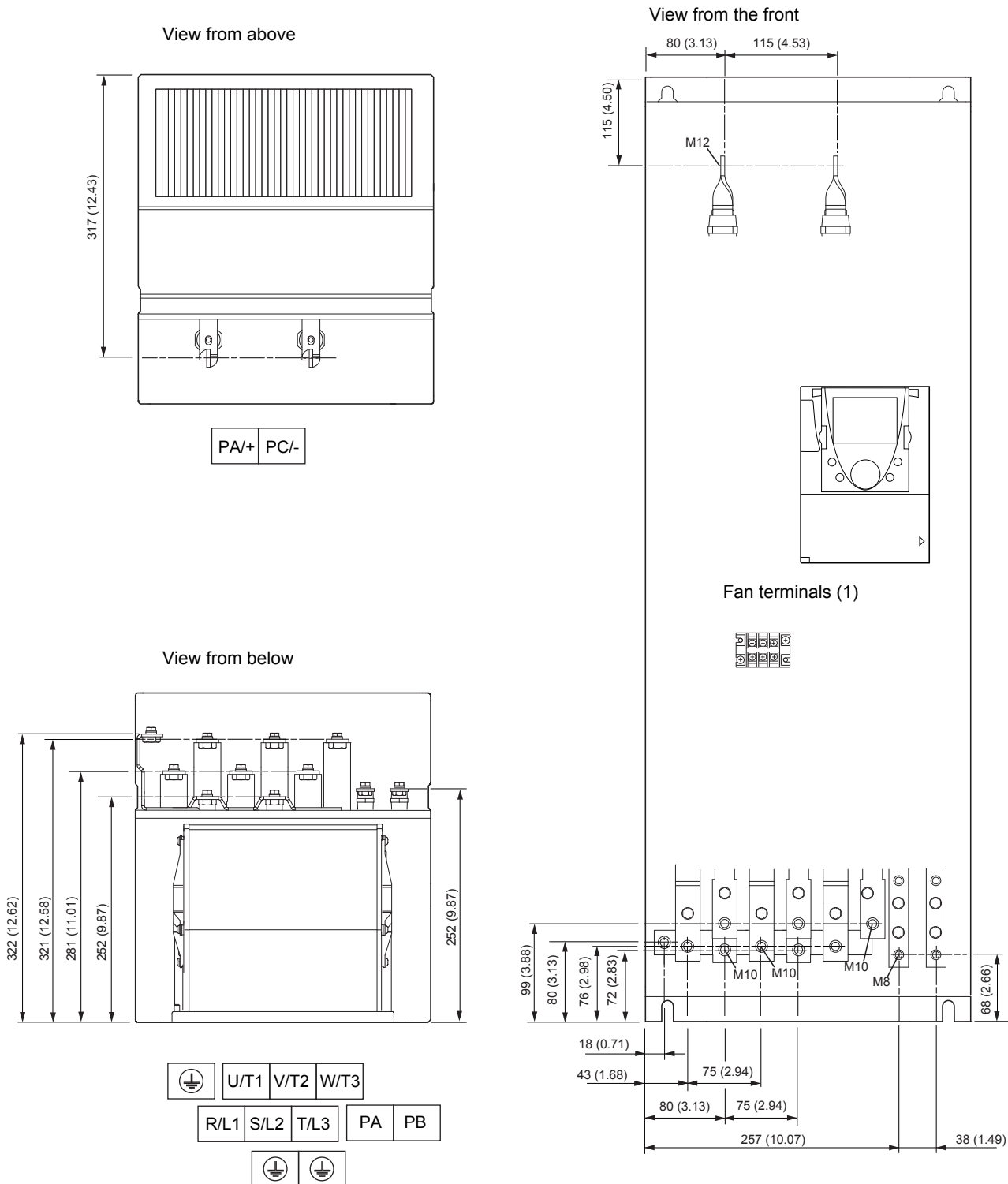

### Maximum terminal wire size/tightening torque

Drive terminals	L1/R, L2/S, L3/T, U/T1, V/T2, W/T3	PC-, PA+	PA, PB	RO, SO, TO (1)
	2 x 120 mm <sup>2</sup> /24 Nm	2 x 120 mm <sup>2</sup> /24 Nm	120 mm <sup>2</sup> /24 Nm	5.5 mm <sup>2</sup> /1.4 Nm
	2 x 250 MCM/212 lb.in	2 x 250 MCM/212 lb.in	250 MCM/212 lb.in	AWG 10/12 lb.in

(1) Fan power supply, compulsory if the drive is powered only by the DC bus. Do not use if the drive is powered with a three-phase supply by L1/R, L2/S, L3/T.



# Power terminals

## ATV71H C20Y, C25Y, C31Y

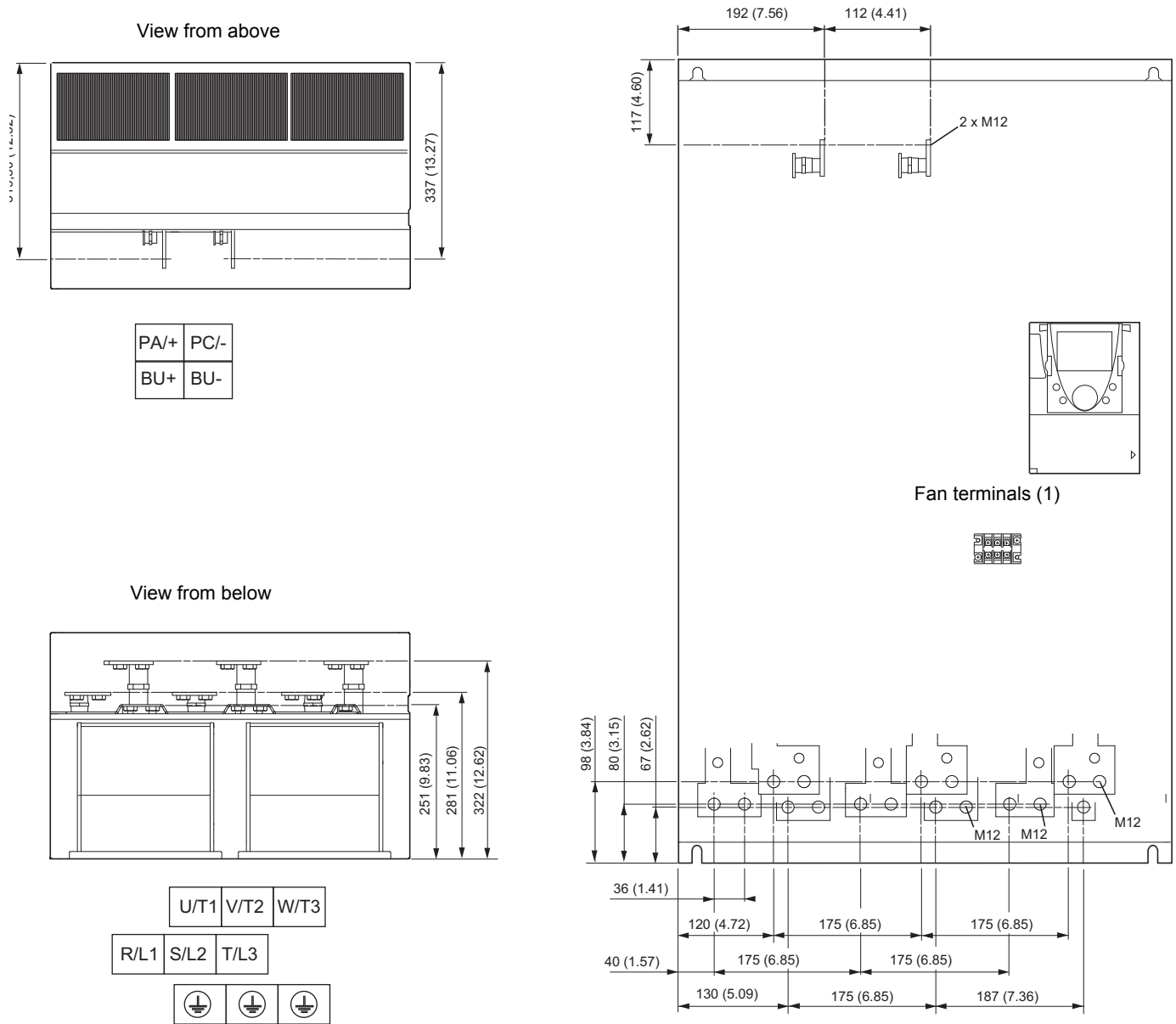

### Maximum terminal wire size/tightening torque

Drive terminals	L1/R, L2/S, L3/T, U/T1, V/T2, W/T3	PC/-, PA/+	RO, SO, TO (1)
	4 x 185 mm <sup>2</sup> /41 Nm	4 x 185 mm <sup>2</sup> /41 Nm	5.5 mm <sup>2</sup> /1.4 Nm
	3 x 350 MCM/360 lb.in	3 x 350 MCM/360 lb.in	AWG 10/12 lb.in

(1) Fan power supply, compulsory if the drive is powered only by the DC bus. Do not use if the drive is powered with a three-phase supply by L1/R, L2/S, L3/T.

# Power terminals

ATV71H C40Y, C50Y, C63Y

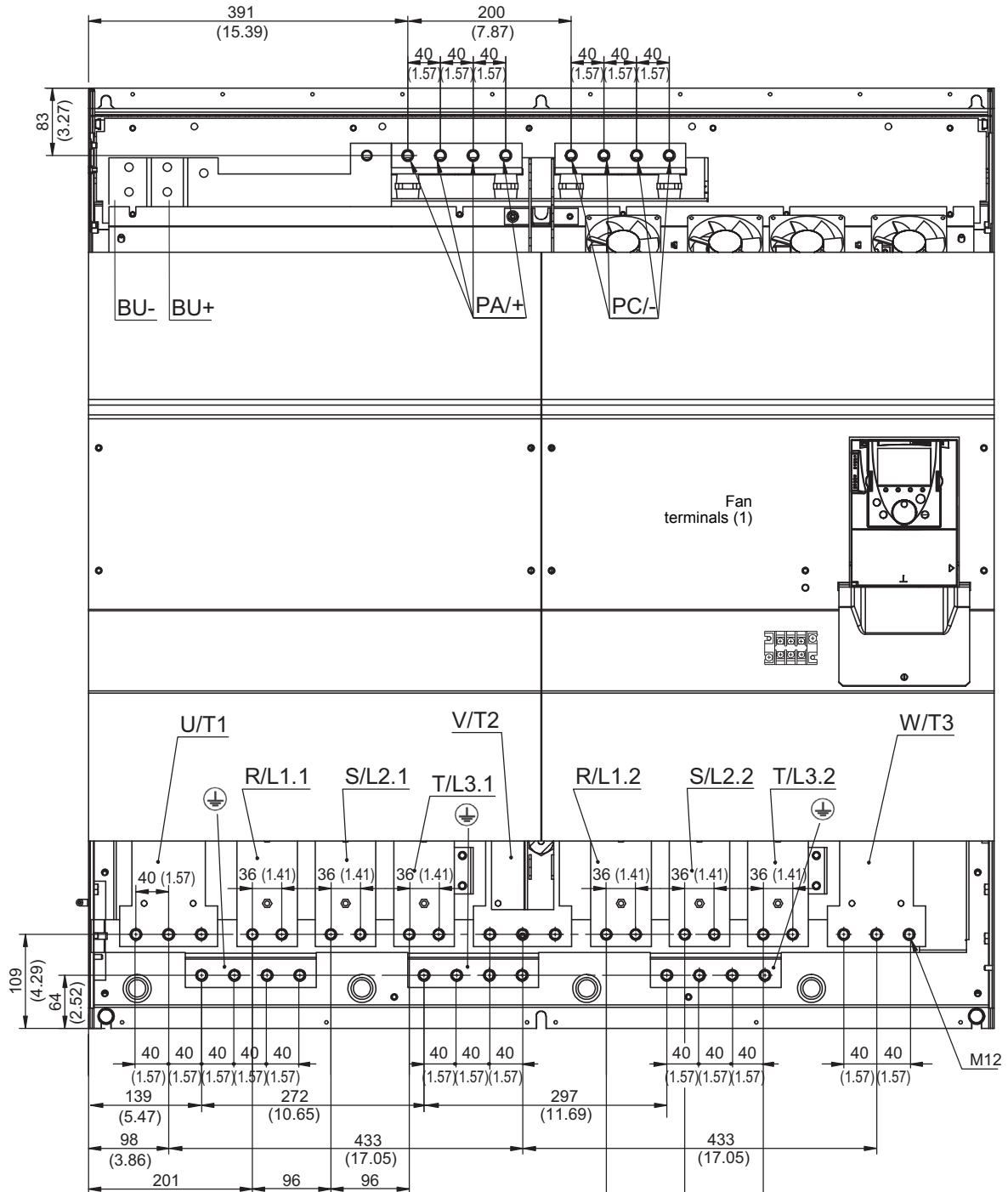

# Power terminals

## ATV71H C40Y, C50Y, C63Y

View from above

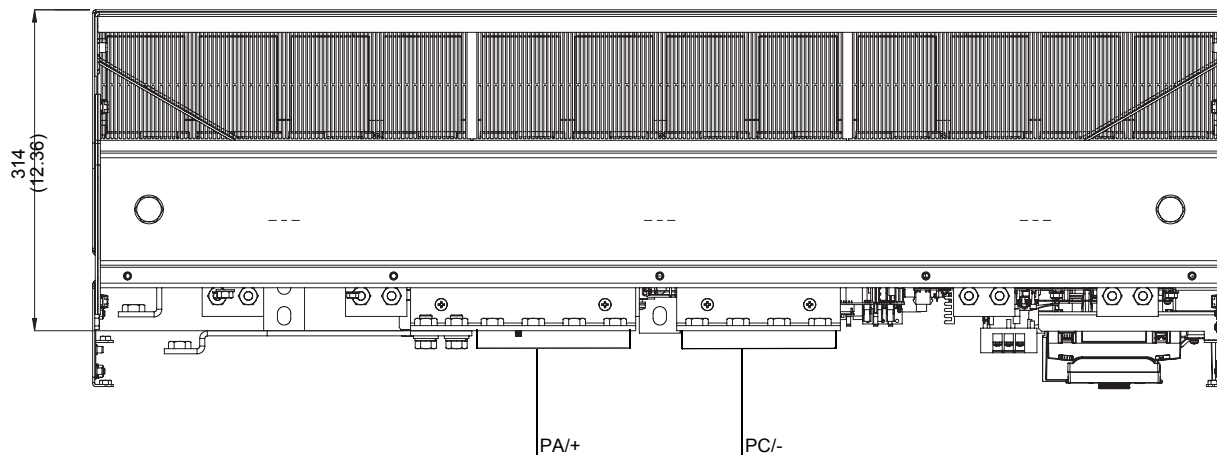

View from below

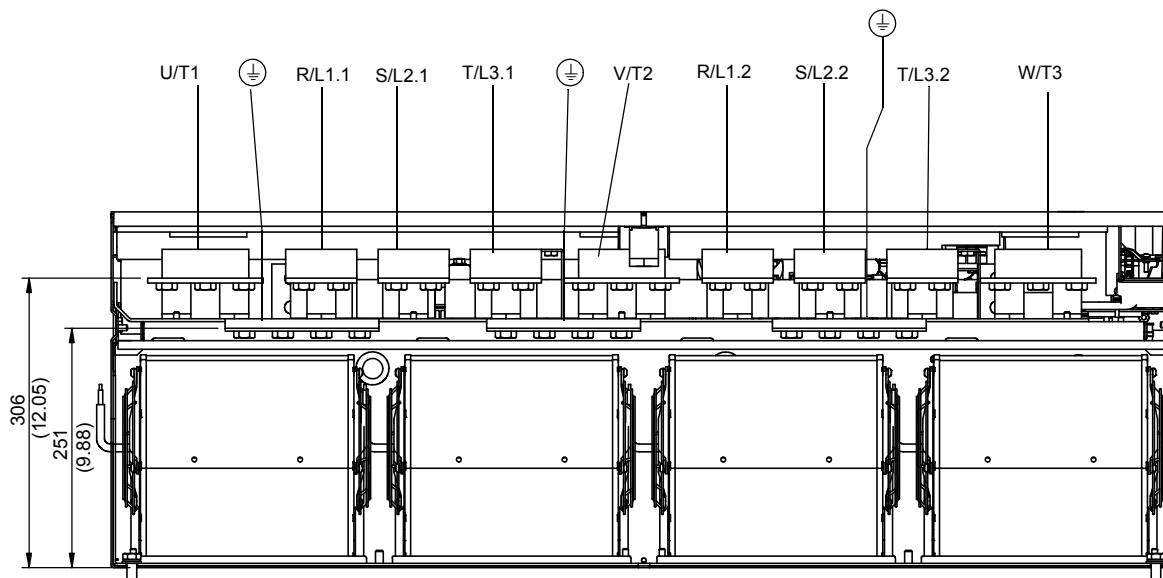

### Maximum terminal wire size/tightening torque

Drive terminals	R/L1.1, R/L1.2, S/L2.1, S/L2.2, T/L3.1, T/L3.2	U/T1, V/T2, W/T3	PC/-, PA/+	RO, SO, TO (1)
	4 x 185 mm <sup>2</sup> /41 Nm	6 x 185 mm <sup>2</sup> /41 Nm	8 x 185 mm <sup>2</sup> /41 Nm	5.5 mm <sup>2</sup> /1.4 Nm
	3 x 500 MCM/360 lb.in	5 x 500 MCM/360 lb.in	5 x 500 MCM/360 lb.in	AWG 10/12 lb.in

(1) Fan power supply, compulsory if the drive is powered only by the DC bus. Do not use if the drive is powered with a three-phase supply by L1/R, L2/S, L3/T.

# Control terminals

## Access to the control terminals

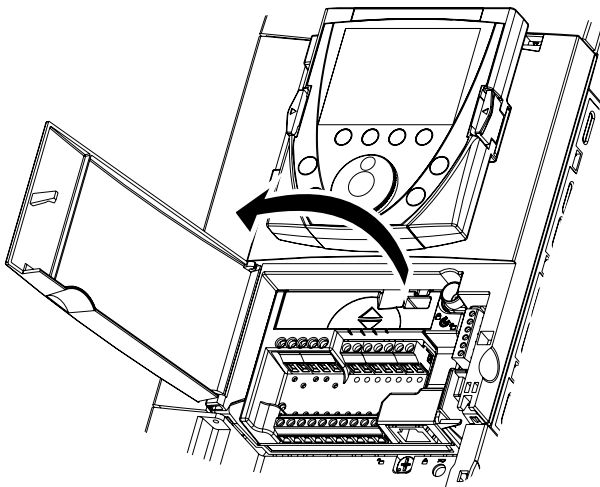

To access the control terminals, open the cover on the control front panel.

## Removing the terminal card

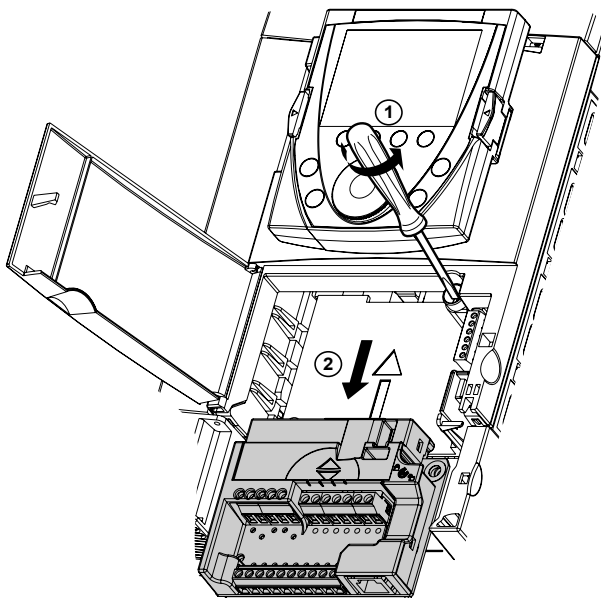

To make it easier to wire the drive control section, the control terminal card can be removed.

- Undo the screw until the spring is fully extended.
- Remove the card by sliding it downwards.

### CAUTION

#### IMPROPERLY SECURED TERMINAL CARD

When replacing the control terminal card, it is essential to fully tighten the captive screw.

**Failure to follow this instruction can result in injury and/or equipment damage.**

## Arrangement of the control terminals

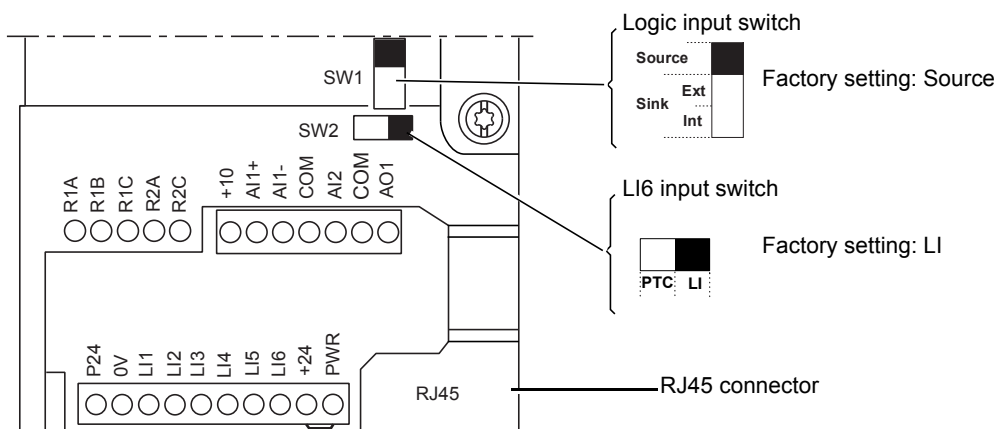

**Note:** The ATV71 is supplied with a link between the PWR and +24 terminals.

# Control terminals

## Characteristics and functions of the control terminals

Terminals	Function	Electrical characteristics									
R1A R1B R1C	Common point C/O contact (R1C) of programmable relay R1	<ul style="list-style-type: none"> <li>Minimum switching capacity: 3 mA for 24 V <math>\overline{\text{DC}}</math></li> <li>Maximum switching capacity on resistive load: 5 A for 250 V <math>\sim</math> or 30 V <math>\overline{\text{DC}}</math></li> </ul>									
R2A R2C	N/O contact of R2 programmable relay	<ul style="list-style-type: none"> <li>Maximum switching current on inductive load (<math>\cos \varphi = 0.4</math> L/R = 7 ms): 2 A for 250 V <math>\sim</math> or 30 V <math>\overline{\text{DC}}</math></li> <li>Reaction time: 7 ms <math>\pm</math> 0.5 ms</li> <li>Service life: 100,000 operations at max. switching power</li> </ul>									
+10	+10 V $\overline{\text{DC}}$ power supply for reference potentiometer 1 to 10 k $\Omega$	<ul style="list-style-type: none"> <li>+10 V <math>\overline{\text{DC}}</math> (10.5 V <math>\pm</math> 0.5 V)</li> <li>10 mA, max.</li> </ul>									
AI1+ AI1 -	Differential analog input AI1	<ul style="list-style-type: none"> <li>-10 to +10 V <math>\overline{\text{DC}}</math> (max. safe voltage 24 V)</li> <li>Reaction time: 2 ms <math>\pm</math> 0.5 ms, 11-bit resolution + 1 sign bit</li> <li>Accuracy <math>\pm</math> 0.6% for <math>\Delta\theta = 60^\circ\text{C}</math> (140°F), linearity <math>\pm</math> 0.15% of max. value</li> </ul>									
COM	Analog I/O common	0 V									
AI2	Depending on software configuration: Analog voltage input  or Analog current input	<ul style="list-style-type: none"> <li>Analog input 0 to +10 V <math>\overline{\text{DC}}</math> (max. safe voltage 24 V), impedance 30 k<math>\Omega</math></li> <li>or</li> <li>Analog input X - Y mA, X and Y can be programmed from 0 to 20 mA</li> <li>Impedance 250 <math>\Omega</math></li> <li>Reaction time: 2 ms <math>\pm</math> 0.5 ms</li> <li>11-bit resolution, accuracy <math>\pm</math> 0.6% for <math>\Delta\theta = 60^\circ\text{C}</math> (140°F), linearity <math>\pm</math> 0.15% of max. value</li> </ul>									
COM	Analog I/O common	0 V									
AO1	Depending on software configuration: Analog voltage output or Analog current output or Logic output	<ul style="list-style-type: none"> <li>Analog output 0 to +10 V <math>\overline{\text{DC}}</math>, load impedance greater than 50 k<math>\Omega</math></li> <li>or</li> <li>Analog output X - Y mA, X and Y can be programmed from 0 to 20 mA</li> <li>Max. load impedance 500 <math>\Omega</math></li> <li>10-bit resolution, reaction time: 2 ms <math>\pm</math> 0.5 ms</li> <li>Accuracy <math>\pm</math> 1% for <math>\Delta\theta = 60^\circ\text{C}</math> (140°F), linearity <math>\pm</math> 0.2% of max. value</li> <li>or</li> <li>Logic output : 0 to +10 V or 0 to 20 mA.</li> </ul>									
P24	Input for external +24 V $\overline{\text{DC}}$ control section power supply	<ul style="list-style-type: none"> <li>+24 V <math>\overline{\text{DC}}</math> (min. 19 V, max. 30 V)</li> <li>Power 30 watts</li> </ul>									
0V	Logic input common and 0 V of P24 external power supply	0 V									
LI1 LI2 LI3 LI4 LI5	Programmable logic inputs	<ul style="list-style-type: none"> <li>+24 V <math>\overline{\text{DC}}</math> (max. 30 V)</li> <li>Impedance 3.5 k<math>\Omega</math></li> <li>Reaction time: 2 ms <math>\pm</math> 0.5 ms</li> </ul> <table border="1" style="margin-left: auto; margin-right: auto;"> <thead> <tr> <th>Switch SW1</th> <th>State 0</th> <th>State 1</th> </tr> </thead> <tbody> <tr> <td>Source (factory setting)</td> <td>&lt; 5 V <math>\overline{\text{DC}}</math></td> <td>&gt; 11 V <math>\overline{\text{DC}}</math></td> </tr> <tr> <td>Sink Int or Sink Ext</td> <td>&gt; 16 V <math>\overline{\text{DC}}</math></td> <td>&lt; 10 V <math>\overline{\text{DC}}</math></td> </tr> </tbody> </table>	Switch SW1	State 0	State 1	Source (factory setting)	< 5 V $\overline{\text{DC}}$	> 11 V $\overline{\text{DC}}$	Sink Int or Sink Ext	> 16 V $\overline{\text{DC}}$	< 10 V $\overline{\text{DC}}$
Switch SW1	State 0	State 1									
Source (factory setting)	< 5 V $\overline{\text{DC}}$	> 11 V $\overline{\text{DC}}$									
Sink Int or Sink Ext	> 16 V $\overline{\text{DC}}$	< 10 V $\overline{\text{DC}}$									
LI6	Depending on the position of switch SW2: - Programmable logic input  or - Input for PTC probes	<ul style="list-style-type: none"> <li>Switch SW2 on LI (factory setting)</li> <li>Same characteristics as logic inputs LI1 to LI5</li> <li>or</li> <li>Switch SW2 on PTC</li> <li>Trip threshold 3 k<math>\Omega</math>, reset threshold 1.8 k<math>\Omega</math></li> <li>Short-circuit detection threshold &lt; 50 <math>\Omega</math></li> </ul>									
+24	Logic input power supply	<ul style="list-style-type: none"> <li>Switch SW1 in Source or Sink Int position</li> <li>+24 V <math>\overline{\text{DC}}</math> power supply (min. 21 V, max. 27 V), protected against short-circuits and overloads</li> <li>Max. current available for customers 200 mA</li> <li>Switch SW1 in Sink Ext position</li> <li>Input for external +24 V <math>\overline{\text{DC}}</math> power supply for the logic inputs</li> </ul>									
PWR	Power Removal safety function input When PWR is not connected to the 24 V, the motor cannot be started (compliance with functional safety standard EN 954-1, ISO 13849-1 and IEC/EN 61508).	<ul style="list-style-type: none"> <li>24 V <math>\overline{\text{DC}}</math> power supply (max. 30 V)</li> <li>Impedance 1.5 k<math>\Omega</math></li> <li>State 0 if &lt; 2 V, state 1 if &gt; 17 V</li> <li>Reaction time: 10 ms</li> </ul>									

# Option terminals

## Logic I/O option card terminals (VW3 A3 201)

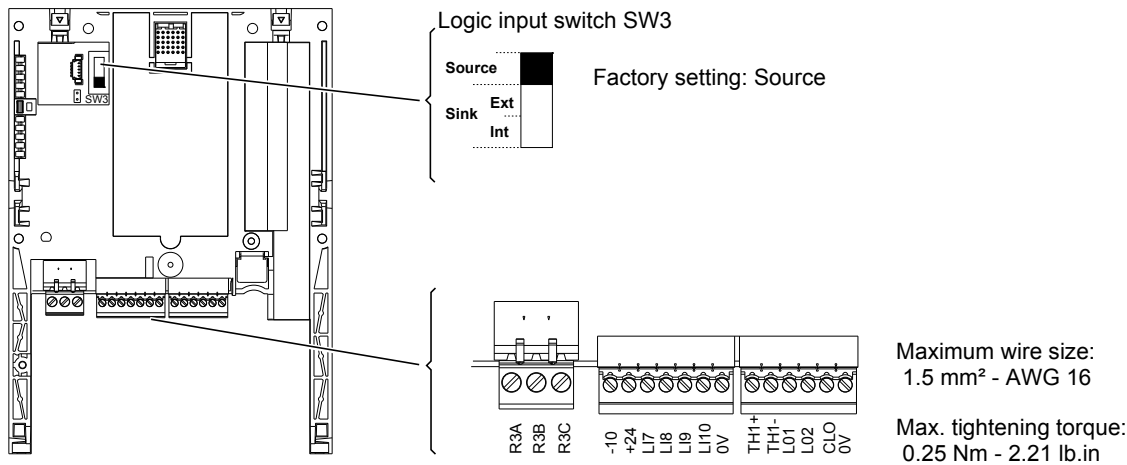

### Characteristics and functions of the terminals

Terminals	Function	Electrical characteristics									
R3A R3B R3C	Common point C/O contact R3C of programmable relay R3	<ul style="list-style-type: none"> <li>Minimum switching capacity: 3 mA for 24 V <math>\text{---}</math></li> <li>Maximum switching capacity on resistive load: 5 A for 250 V <math>\sim</math> or 30 V <math>\text{---}</math></li> <li>Maximum switching capacity on inductive load (<math>\cos \varphi = 0.4</math> L/R = 7 ms): 2 A for 250 V <math>\sim</math> or 30 V <math>\text{---}</math></li> <li>Reaction time: 7 ms <math>\pm</math> 0.5 ms</li> <li>Service life: 100,000 operations</li> </ul>									
-10	-10 V $\text{---}$ power supply for reference potentiometer 1 to 10 k $\Omega$	<ul style="list-style-type: none"> <li>-10 V <math>\text{---}</math> (-10.5 V <math>\pm</math> 0.5 V)</li> <li>10 mA, max.</li> </ul>									
+24	Logic input power supply	<p>Switch SW3 in Source or Sink Int position</p> <ul style="list-style-type: none"> <li>+24 V <math>\text{---}</math> power supply (min. 21 V, max. 27 V), protected against short-circuits and overloads</li> <li>Max. current available for customers 200 mA (this corresponds to the total consumption on the control card +24 and the option cards +24)</li> </ul> <p>Switch SW3 in Sink Ext position</p> <ul style="list-style-type: none"> <li>Input for external +24 V <math>\text{---}</math> power supply for the logic inputs</li> </ul>									
L17 L18 L19 L110	Programmable logic inputs	<ul style="list-style-type: none"> <li>+24 V <math>\text{---}</math> power supply (max. 30 V)</li> <li>Impedance 3.5 k<math>\Omega</math></li> <li>Reaction time 2 ms <math>\pm</math> 0.5 ms</li> </ul> <table border="1"> <thead> <tr> <th>Switch SW3</th> <th>State 0</th> <th>State 1</th> </tr> </thead> <tbody> <tr> <td>Source (factory setting)</td> <td>&lt; 5 V <math>\text{---}</math></td> <td>&gt; 11 V <math>\text{---}</math></td> </tr> <tr> <td>Sink Int or Sink Ext</td> <td>&gt; 16 V <math>\text{---}</math></td> <td>&lt; 10 V <math>\text{---}</math></td> </tr> </tbody> </table>	Switch SW3	State 0	State 1	Source (factory setting)	< 5 V $\text{---}$	> 11 V $\text{---}$	Sink Int or Sink Ext	> 16 V $\text{---}$	< 10 V $\text{---}$
Switch SW3	State 0	State 1									
Source (factory setting)	< 5 V $\text{---}$	> 11 V $\text{---}$									
Sink Int or Sink Ext	> 16 V $\text{---}$	< 10 V $\text{---}$									
0V	0 V	0 V									
TH1+ TH1-	PTC probe input	<ul style="list-style-type: none"> <li>Trip threshold 3 k<math>\Omega</math>, reset threshold 1.8 k<math>\Omega</math></li> <li>Short-circuit detection threshold &lt; 50 <math>\Omega</math></li> </ul>									
LO1 LO2	Open collector programmable logic outputs	<ul style="list-style-type: none"> <li>+24 V <math>\text{---}</math> (max. 30 V)</li> <li>Max. current 200 mA for internal power supply and 200 mA for external power supply</li> <li>Reaction time: 2 ms <math>\pm</math> 0.5 ms</li> </ul>									
CLO	Logic output common										
0V	0 V	0 V									

# Option terminals

## Extended I/O option card terminals (VW3 A3 202)

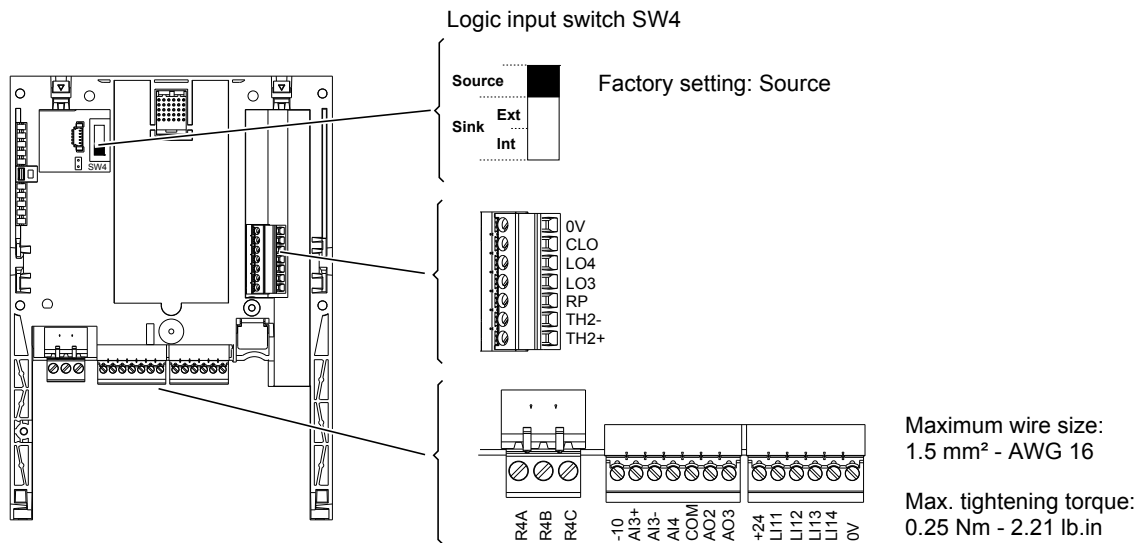

### Characteristics and functions of the terminals

Terminals	Function	Electrical characteristics
R4A R4B R4C	Common point C/O contact R4C of programmable relay R4	<ul style="list-style-type: none"> <li>Minimum switching capacity: 3 mA for 24 V <math>\overline{\text{---}}</math></li> <li>Maximum switching capacity on resistive load: 5 A for 250 V <math>\sim</math> or 30 V <math>\overline{\text{---}}</math></li> <li>Maximum switching capacity on inductive load (<math>\cos \varphi = 0.4</math> L/R = 7 ms): 1.5 A for 250 V <math>\sim</math> or 30 V <math>\overline{\text{---}}</math></li> <li>Reaction time 10 ms <math>\pm</math> 1 ms</li> <li>Service life: 100,000 operations</li> </ul>
-10	-10 V $\overline{\text{---}}$ power supply for reference potentiometer 1 to 10 k $\Omega$	<ul style="list-style-type: none"> <li>-10 V <math>\overline{\text{---}}</math> (-10.5 V <math>\pm</math> 0.5 V)</li> <li>10 mA, max.</li> </ul>
AI3 +	+ polarity of the current differential analog input AI3	<ul style="list-style-type: none"> <li>Analog input X - Y mA, X and Y can be programmed from 0 to 20 mA, impedance 250 <math>\Omega</math></li> <li>Reaction time: 5 ms <math>\pm</math> 1 ms</li> <li>11-bit resolution + 1 sign bit, accuracy <math>\pm</math> 0.6% for <math>\Delta\theta = 60^\circ\text{C}</math> (140°F)</li> <li>Linearity <math>\pm</math> 0.15% of max. value</li> </ul>
AI3 -	- polarity of the current differential analog input AI3	
AI4	Depending on software configuration: Analog current input  or Analog voltage input	<ul style="list-style-type: none"> <li>Analog input 0 to +10 V <math>\overline{\text{---}}</math> (max. safe voltage 24 V), impedance 30 k<math>\Omega</math></li> <li>or</li> <li>Analog input X - Y mA, X and Y can be programmed from 0 to 20 mA, impedance 250 <math>\Omega</math></li> <li>Reaction time: 5 ms <math>\pm</math> 1 ms</li> <li>11-bit resolution, accuracy <math>\pm</math> 0.6% for <math>\Delta\theta = 60^\circ\text{C}</math> (140°F), linearity <math>\pm</math> 0.15% of max. value</li> </ul>
COM	Analog I/O common	0 V
AO2 AO3	Depending on software configuration: Analog voltage outputs  or Analog current outputs	<ul style="list-style-type: none"> <li>0 - 10 V <math>\overline{\text{---}}</math> or -10/+10 V <math>\overline{\text{---}}</math> bipolar analog output depending on software configuration, load impedance greater than 50 k<math>\Omega</math></li> <li>or</li> <li>Analog current output X-Y mA, X and Y can be programmed from 0 to 20 mA, max. load impedance 500 <math>\Omega</math></li> <li>10-bit resolution</li> <li>Reaction time 5 ms <math>\pm</math> 1 ms, accuracy <math>\pm</math> 1% for <math>\Delta\theta = 60^\circ\text{C}</math> (140°F), linearity <math>\pm</math> 0.2%</li> </ul>

# Option terminals

Terminals	Function	Electrical characteristics									
+24	Logic input power supply	Switch SW4 in Source or Sink Int position <ul style="list-style-type: none"> <li>+24 V <math>\overline{\text{---}}</math> output (min. 21 V, max. 27 V), protected against short-circuits and overloads</li> <li>Max. current available for customers 200 mA (this corresponds to the total consumption on the control card +24 and the option cards +24)</li> </ul> Switch SW4 in Sink Ext position <ul style="list-style-type: none"> <li>Input for external +24 V <math>\overline{\text{---}}</math> power supply for the logic inputs</li> </ul>									
LI11 LI12 LI13 LI14	Programmable logic inputs	<ul style="list-style-type: none"> <li>+24 V <math>\overline{\text{---}}</math> (max. 30 V)</li> <li>Impedance 3.5 k<math>\Omega</math></li> <li>Reaction time: 5 ms <math>\pm</math> 1 ms</li> </ul> <table border="1" style="margin-left: auto; margin-right: auto;"> <thead> <tr> <th>Switch SW4</th> <th>State 0</th> <th>State 1</th> </tr> </thead> <tbody> <tr> <td>Source (factory setting)</td> <td>&lt; 5 V <math>\overline{\text{---}}</math></td> <td>&gt; 11 V <math>\overline{\text{---}}</math></td> </tr> <tr> <td>Sink Int or Sink Ext</td> <td>&gt; 16 V <math>\overline{\text{---}}</math></td> <td>&lt; 10 V <math>\overline{\text{---}}</math></td> </tr> </tbody> </table>	Switch SW4	State 0	State 1	Source (factory setting)	< 5 V $\overline{\text{---}}$	> 11 V $\overline{\text{---}}$	Sink Int or Sink Ext	> 16 V $\overline{\text{---}}$	< 10 V $\overline{\text{---}}$
Switch SW4	State 0	State 1									
Source (factory setting)	< 5 V $\overline{\text{---}}$	> 11 V $\overline{\text{---}}$									
Sink Int or Sink Ext	> 16 V $\overline{\text{---}}$	< 10 V $\overline{\text{---}}$									
0V	Logic input common	0 V									
TH2 + TH2 -	PTC probe input	<ul style="list-style-type: none"> <li>Trip threshold 3 k<math>\Omega</math>, reset threshold 1.8 k<math>\Omega</math></li> <li>Short-circuit detection threshold &lt; 50 <math>\Omega</math></li> </ul>									
RP	Frequency input	<ul style="list-style-type: none"> <li>Frequency range: 0...30 kHz</li> <li>Cyclic ratio: 50% <math>\pm</math> 10%</li> <li>Maximum sampling time: 5 ms <math>\pm</math> 1 ms</li> <li>Maximum input voltage 30 V, 15 mA</li> <li>Add a resistor if the input voltage is greater than 5 V (510 <math>\Omega</math> for 12 V, 910 <math>\Omega</math> for 15 V, 1.3 k<math>\Omega</math> for 24 V)</li> <li>State 0 if &lt; 1.2 V, state 1 if &gt; 3.5 V</li> </ul>									
LO3 LO4	Open collector programmable logic outputs	<ul style="list-style-type: none"> <li>+24 V <math>\overline{\text{---}}</math> (max. 30 V)</li> <li>Max. current 20 mA for internal power supply and 200 mA for external power supply</li> <li>Reaction time 5 ms <math>\pm</math> 1ms</li> </ul>									
CLO	Logic output common										
0V	0 V	0 V									



# Option terminals

## Encoder interface card terminals

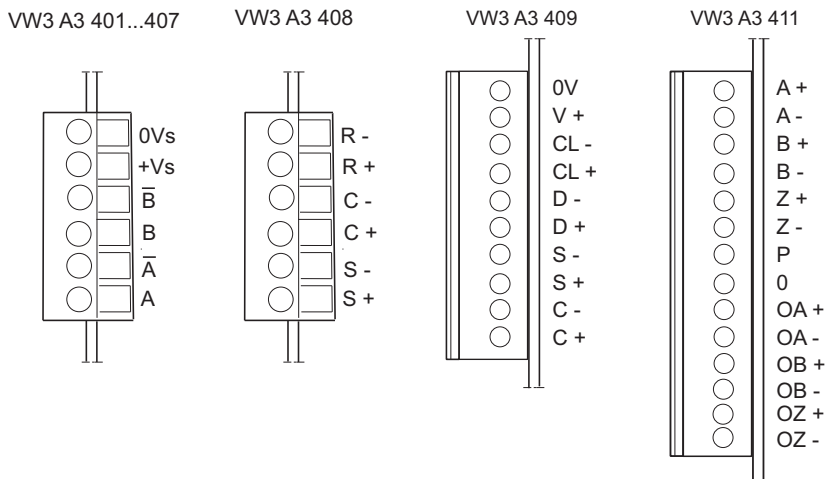

Maximum wire size:  
1.5 mm<sup>2</sup> - AWG 16

Max. tightening torque:  
0.25 Nm - 2.21 lb.in

## Characteristics and functions of the terminals

### Encoder interface cards with RS422-compatible differential outputs

Terminals	Function	Electrical characteristics	
		VW3 A3 401	VW3 A3 402
+Vs 0Vs	Power supply for encoder	<ul style="list-style-type: none"> <li>5 V <math>\bar{\text{---}}</math> (max. 5.5 V) protected against short-circuits and overloads</li> <li>Max. current 200 mA</li> </ul>	<ul style="list-style-type: none"> <li>15 V <math>\bar{\text{---}}</math> (max. 16 V) protected against short-circuits and overloads</li> <li>Max. current 175 mA</li> </ul>
A, /A B, /B	Incremental logic inputs	<ul style="list-style-type: none"> <li>Max. resolution: 5,000 points/rev</li> <li>Max. frequency: 300 kHz</li> <li>Nominal input voltage: 5 V</li> </ul>	

### Encoder interface cards with open collector outputs

Terminals	Function	Electrical characteristics	
		VW3 A3 403	VW3 A3 404
+Vs 0Vs	Power supply for encoder	<ul style="list-style-type: none"> <li>12 V <math>\bar{\text{---}}</math> (max. 13 V) protected against short-circuits and overloads</li> <li>Max. current 175 mA</li> </ul>	<ul style="list-style-type: none"> <li>15 V <math>\bar{\text{---}}</math> (max. 16 V) protected against short-circuits and overloads</li> <li>Max. current 175 mA</li> </ul>
A, /A B, /B	Incremental logic inputs	<ul style="list-style-type: none"> <li>Max. resolution: 5,000 points/rev</li> <li>Max. frequency: 300 kHz</li> </ul>	

### Encoder interface cards with push-pull outputs

Terminals	Function	Electrical characteristics		
		VW3 A3 405	VW3 A3 406	VW3 A3 407
+Vs 0Vs	Power supply for encoder	<ul style="list-style-type: none"> <li>12 V <math>\bar{\text{---}}</math> (max. 13 V) protected against short-circuits and overloads</li> <li>Max. current 175 mA</li> </ul>	<ul style="list-style-type: none"> <li>15 V <math>\bar{\text{---}}</math> (max. 16 V) protected against short-circuits and overloads</li> <li>Max. current 175 mA</li> </ul>	<ul style="list-style-type: none"> <li>24 V <math>\bar{\text{---}}</math> (min. 20V, max. 30V) protected against short-circuits and overloads</li> <li>Max. current 100 mA</li> </ul>
A, /A B, /B	Incremental logic inputs	<ul style="list-style-type: none"> <li>Max. resolution: 5,000 points/rev</li> <li>Max. frequency: 300 kHz</li> </ul>		

### Resolver encoder interface card (ATV ... 383)

Terminals	Function	Electrical characteristics
		VW3 A3 408
R - R +	Reference excitation	<ul style="list-style-type: none"> <li>Nominal voltage: 1.25 to 5.6 V rms</li> <li>Maximum current: 50 mA</li> </ul>
C - C +	Cosine signals	<ul style="list-style-type: none"> <li>Transformation ratio: Automatic detection (4/1 - 3/1 - 2/1 - 1/1)</li> <li>Excitation frequency: 4 - 8 - 12 kHz</li> <li>Resolution: 12 bits for 360° electrical <math>\pm</math> 1 bit</li> </ul>
S - S +	Sine signals	<ul style="list-style-type: none"> <li>Number of poles/max. speed: 2/7,500 rpm - 4/3,750 rpm - 6/2,500 rpm - 8/1,875 rpm</li> </ul>

# Option terminals

## SinCos, SinCosHiperface, EnDat, SSI encoder interface card (ATV ... 383)

Terminals	Function	Electrical characteristics		
		VW3 A3 409		
0V V+	Power supply for encoder	<ul style="list-style-type: none"> <li>5 V <math>\overline{\text{---}}</math> (max. 5.5 V) protected against short-circuits and overloads</li> <li>Max. current 200 mA</li> </ul>	<ul style="list-style-type: none"> <li>8 V <math>\overline{\text{---}}</math> (max. 8.5 V) protected against short-circuits and overloads</li> <li>Max. current 200 mA</li> </ul>	<ul style="list-style-type: none"> <li>12 V <math>\overline{\text{---}}</math> (max. 12.5 V) protected against short-circuits and overloads</li> <li>Max. current 200 mA</li> </ul>
CL - CL +	Clock	<ul style="list-style-type: none"> <li>Fixed clock frequency: 500 kHz</li> <li>Max. speed feedback resolution: <math>2^{13}</math></li> </ul>		
D - D +	Data			
S - S +	Sine signals			
C - C +	Cosine signals			

## Encoder interface card with RS422-compatible differential outputs with encoder emulation

Terminals	Function	Electrical characteristics	
		VW3 A3 411	
P 0	Power supply for encoder	<ul style="list-style-type: none"> <li>5 V <math>\overline{\text{---}}</math> (max. 5.5 V) protected against short-circuits and overloads</li> <li>Max. current 200 mA</li> </ul>	<ul style="list-style-type: none"> <li>15 V <math>\overline{\text{---}}</math> (max. 16 V) protected against short-circuits and overloads</li> <li>Max. current 200 mA</li> </ul>
A+, A- B+, B- Z+, Z-	Logic inputs	<ul style="list-style-type: none"> <li>Max. resolution: 10,000 points/rev</li> <li>Max. frequency: 300 kHz</li> </ul>	
OA+, OA- OB+, OB- OZ+, OZ-	Logic outputs	<ul style="list-style-type: none"> <li>Selectable ratio: 1, 1/2, 1/4, 1/8, 1/16, 1/32, 1/64</li> <li>Max. frequency: 300 kHz</li> </ul>	

This encoder card has two sets of parameterization switches:

- The first is used to select the supply voltage provided by the interface card to the encoder: 5 V or 15 V.
- The second is a set of 5 switches numbered from 1 to 5 (see below). The division ratio for the ESIM outputs is selected using switches 1, 2 and 3. Switches 4 and 5 are used to select the input signals used on the encoder card. Fault detection will be inhibited for inputs selected via these switches.

1	2	3	ESIM outputs
ON	ON	ON	A and B divided by 1
ON	ON	OFF	A and B divided by 2
ON	OFF	ON	A and B divided by 4
ON	OFF	OFF	A and B divided by 8
OFF	ON	ON	A and B divided by 16
OFF	ON	OFF	A and B divided by 32
OFF	OFF	ON	A and B divided by 64
OFF	OFF	OFF	ESIM deactivated

4	5	Encoder inputs
ON	ON	Encoder A, B and Z
ON	OFF	Encoder A and B
OFF	ON	Encoder A and B
OFF	OFF	Encoder A



## Selecting an encoder

The encoder interface cards available as an option with the ATV71 enable different encoder technologies to be used (incremental or absolute).

- Incremental encoder with RS422-compatible differential outputs
- Incremental encoder with open collector outputs
- Incremental encoder with push-pull outputs
- Incremental encoder with RS422-compatible differential outputs with encoder emulation
- Resolver absolute encoder
- SinCos incremental encoder, SinCosHiperface absolute encoder, EnDat absolute encoder, SSI absolute encoder

The VW3 A3 408 and VW3 A3 409 encoder cards available as an option with the ATV71 specification 383 can be used with a synchronous or asynchronous motor for closed-loop control.

# Option terminals

## Wiring an encoder

Use a shielded cable containing 3 twisted pairs with a pitch of between 25 and 50 mm (0.98 in. and 1.97 in.). Connect the shielding to ground at both ends.

The minimum cross-section of the conductors must comply with the table below, in order to limit line voltage drop:

Max. encoder cable length	VW3 A3 401...402			VW3 A3 403...407		
	Max. consumption current of encoder	Minimum cross-section of conductors		Max. consumption current of encoder	Minimum cross-section of conductors	
10 m 32.8 ft	100 mA	0.2 mm <sup>2</sup>	AWG 24	100 mA	0.2 mm <sup>2</sup>	AWG 24
	200 mA	0.2 mm <sup>2</sup>	AWG 24	200 mA	0.2 mm <sup>2</sup>	AWG 24
50 m 164 ft	100 mA	0.5 mm <sup>2</sup>	AWG 20	100 mA	0.5 mm <sup>2</sup>	AWG 20
	200 mA	0.75 mm <sup>2</sup>	AWG 18	200 mA	0.75 mm <sup>2</sup>	AWG 18
100 m 328 ft	100 mA	0.75 mm <sup>2</sup>	AWG 18	100 mA	0.75 mm <sup>2</sup>	AWG 18
	200 mA	1.5 mm <sup>2</sup>	AWG 15	200 mA	1.5 mm <sup>2</sup>	AWG 15
200 m 656 ft	-	-	-	100 mA	0.5 mm <sup>2</sup>	AWG 20
	-	-	-	200 mA	1.5 mm <sup>2</sup>	AWG 15
300 m 984 ft	-	-	-	100 mA	0.75 mm <sup>2</sup>	AWG 18
	-	-	-	200 mA	1.5 mm <sup>2</sup>	AWG 15

Max. encoder cable length	VW3 A3 408			VW3 A3 409		
	Max. consumption current of encoder	Minimum cross-section of conductors		Max. consumption current of encoder	Minimum cross-section of conductors	
25 m 82 ft	30 mA	0.2 mm <sup>2</sup>	AWG 24	100 mA	0.5 mm <sup>2</sup>	AWG 20
	50 mA	0.2 mm <sup>2</sup>	AWG 24	200 mA	1 mm <sup>2</sup>	AWG 17
50 m 164 ft	30 mA	0.2 mm <sup>2</sup>	AWG 24	100 mA	0.75 mm <sup>2</sup>	AWG 18
	50 mA	0.5 mm <sup>2</sup>	AWG 20	200 mA	1.5 mm <sup>2</sup>	AWG 15
100 m 328 ft	30 mA	0.5 mm <sup>2</sup>	AWG 20	-	-	-
	50 mA	0.5 mm <sup>2</sup>	AWG 20	-	-	-
200 m 656 ft	30 mA	0.75 mm <sup>2</sup>	AWG 18	-	-	-
	50 mA	1 mm <sup>2</sup>	AWG 17	-	-	-

Max. encoder cable length	VW3 A3 411				
	Max. consumption current of encoder	Minimum cross-section of conductors			
		15 V power supply		5 V power supply	
25 m 82 ft	100 mA	0.2 mm <sup>2</sup>	AWG 24	0.5 mm <sup>2</sup>	AWG 20
	200 mA	0.5 mm <sup>2</sup>	AWG 20	1 mm <sup>2</sup>	AWG 17
50 m 164 ft	100 mA	0.5 mm <sup>2</sup>	AWG 20	0.75 mm <sup>2</sup>	AWG 18
	200 mA	0.75 mm <sup>2</sup>	AWG 18	1.5 mm <sup>2</sup>	AWG 15
100 m 328 ft	100 mA	0.75 mm <sup>2</sup>	AWG 18	-	-
	200 mA	1.5 mm <sup>2</sup>	AWG 15	-	-

# Connection diagrams

## Connection diagrams conforming to standards EN 954-1 category 1, ISO 13849-1 and IEC/EN 61508 capacity SIL1, stopping category 0 in accordance with standard IEC/EN 60204-1

Diagram with line contactor

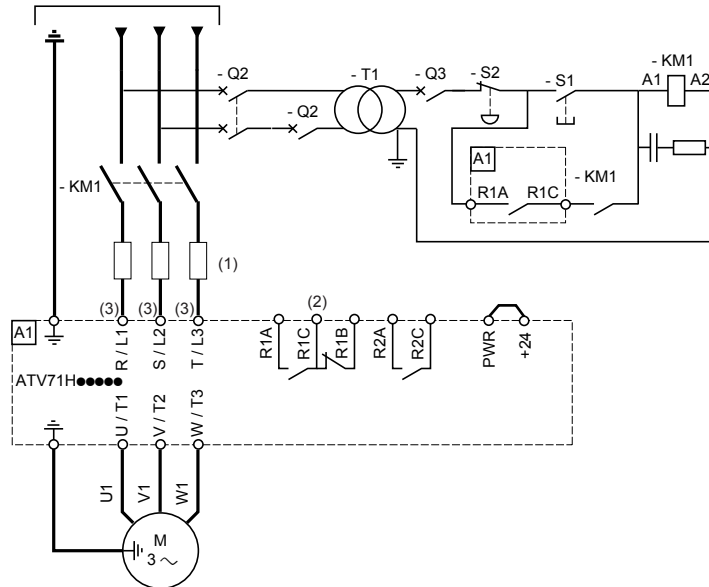
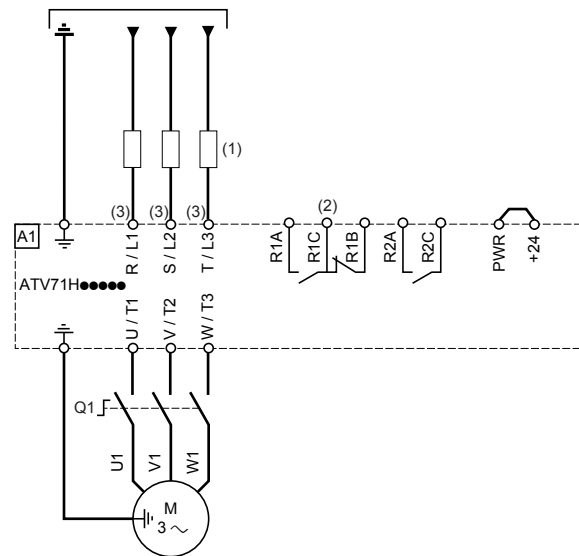

Diagram with switch disconnect



- (1) Line choke, optional for ATV71H●●●M3X and ATV71H●●●N4, compulsory for ATV71H●●●Y drives (to be ordered separately) if a special transformer is not used (e.g., 12-pulse).
- (2) Fault relay contacts, for remote signaling of drive status
- (3) For the wiring of the power section AC supply for ATV71H C40N4, C50N4, C40Y, C50Y and C63Y drives please refer to page [63](#).

**Note:** Install interference suppressors on all inductive circuits near the drive or coupled to the same circuit (relays, contactors, solenoid valves, etc).

**Choice of associated components:**  
Please refer to the catalog.

# Connection diagrams

## Connection diagrams conforming to standards EN 954-1 category 3, ISO 13849-1 and IEC/EN 61508 capacity SIL2, stopping category 0 in accordance with standard IEC/EN 60204-1

This connection diagram is suitable for use with machines with a short freewheel stop time (machines with low inertia or high resistive torque). When the emergency stop is activated, the drive power supply is cut immediately and the motor stops in accordance with category 0 of standard IEC/EN 60204-1.

 **This diagram must be used for hoisting applications.**

A contact on the Preventa XPS AC module must be inserted in the brake control circuit to engage it safely when the Power Removal safety function is activated.

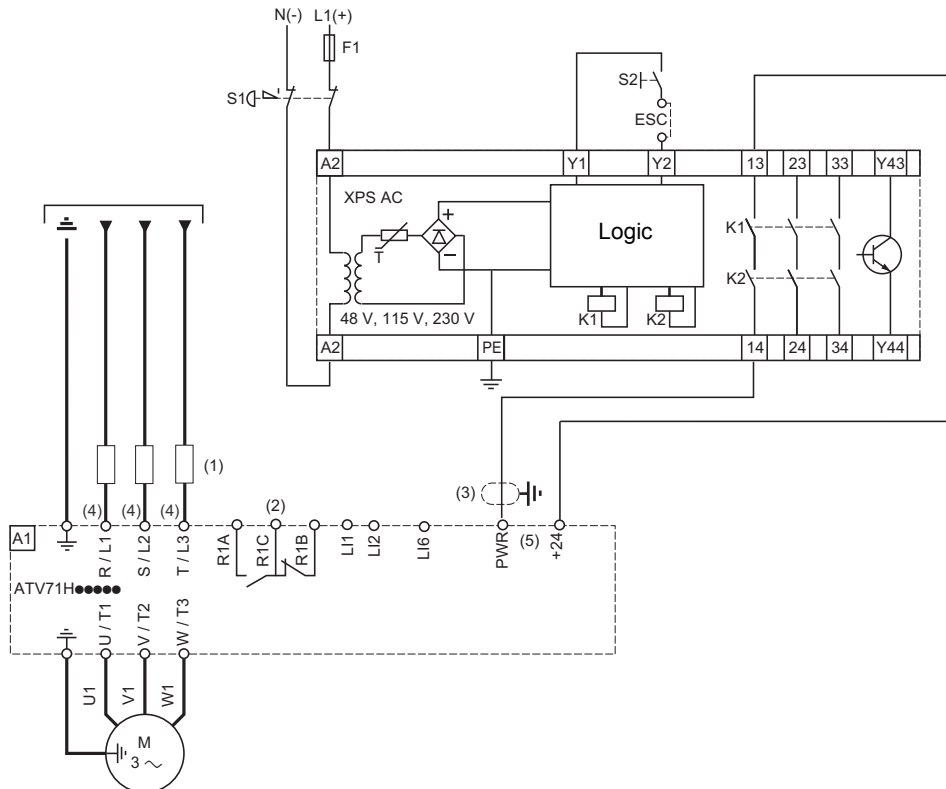

- (1) Line choke, optional for ATV71H●●●M3X and ATV71H●●●N4, compulsory for ATV71H●●●Y (to be ordered separately) if a special transformer is not used (e.g., 12-pulse).
- (2) Fault relay contacts, for remote signaling of drive status
- (3) It is essential to connect the shielding on the cable connected to the Power Removal input to ground.
- (4) For the wiring of the power section AC supply for ATV71H C40N4, C50N4, C40Y, C50Y and C63Y drives please refer to page 63.
- (5) Use cable ends DZ5CE020 (yellow) on wires connected to PWR and +24 inputs.

- Standard EN 954-1 category 3 and ISO 13849-1 require the use of a stop button with double contact (S1).
- S1 is used to activate the Power Removal safety function.
- S2 is used to initialize the Preventa module when powering up or after an emergency stop. ESC enables the use of other initialization conditions for the module.
- One Preventa module can be used for the Power Removal safety function on several ATV71 drives.
- A logic input on the Preventa module can be used to indicate reliably that the drive is operating in safe conditions.

### Note:

For preventive maintenance, the Power Removal function must be activated at least once a year.

The drive power supply must be turned off and then on again before carrying out this preventive maintenance.

The drive logic output signals cannot be considered as safety-type signals.

Install interference suppressors on all inductive circuits near the drive or coupled to the same circuit (relays, contactors, solenoid valves, etc).

### Choice of associated components:

Please refer to the catalog.

# Connection diagrams

## Connection diagrams conforming to standards EN 954-1 category 3, ISO 13849-1 and IEC/EN 61508 capacity SIL2, stopping category 1 in accordance with standard IEC/EN 60204-1

This connection diagram is suitable for use with machines with a long freewheel stop time (machines with high inertia or low resistive torque).

 **This diagram must not be used for hoisting applications.**

When the emergency stop is activated, deceleration of the motor controlled by the drive is requested first. Then, after a time delay corresponding to the deceleration time, the Power Removal safety function is activated.

### Example:

- 2-wire control
- LI1 assigned to forward
- LI2 assigned to reverse

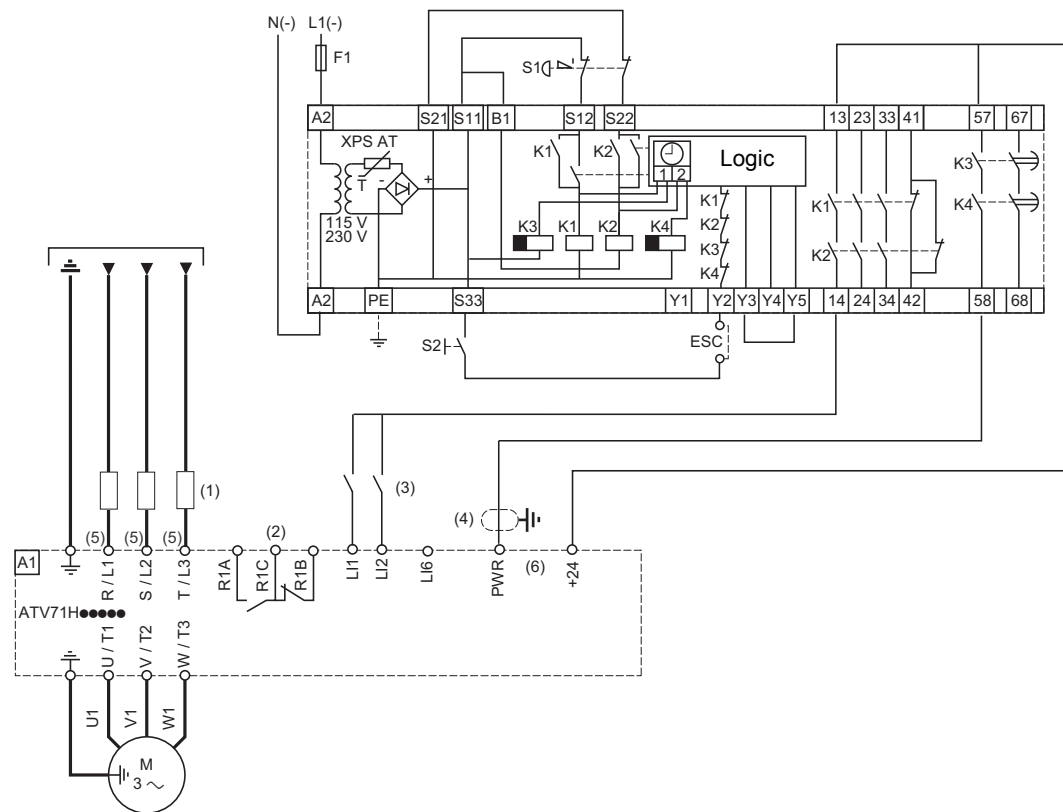

- (1) Line choke, optional for ATV71H●●●M3X and ATV71H●●●N4, compulsory for ATV71H●●●Y (to be ordered separately) if a special transformer is not used (e.g., 12-pulse).
- (2) Fault relay contacts, for remote signaling of drive status
- (3) In this example, the logic inputs Lix are wired as "Source" but can be wired as "Sink Int" or "Sink Ext" (please refer to page 64).
- (4) It is essential to connect the shielding on the cable connected to the Power Removal input to ground.
- (5) For the wiring of the power section AC supply for ATV71H C40N4, C50N4, C40Y, C50Y and C63Y drives please refer to page 63.
- (6) Use cable ends DZ5CE020 (yellow) on wires connected to PWR and +24 inputs.

- Standard EN 954-1 category 3 and ISO 13849-1 require the use of an emergency stop with double contact (S1).
- S1 is used to activate the Power Removal safety function.
- S2 is used to initialize the Preventa module when powering up or after an emergency stop. ESC enables the use of other initialization conditions for the module.
- One Preventa module can be used for the Power Removal safety function on several ATV71 drives. In this case the time delay must be set to the longest stopping time.
- A logic input on the Preventa module can be used to indicate reliably that the drive is operating in safe conditions.

**Note:** For preventive maintenance, the Power Removal function must be activated at least once a year.

The drive power supply must be turned off and then on again before carrying out this preventive maintenance.

The drive logic output signals cannot be considered as safety-type signals.

Install interference suppressors on all inductive circuits near the drive or coupled to the same circuit (relays, contactors, solenoid valves, etc).

### Choice of associated components:

Please refer to the catalog.

# Connection diagrams

## Connection diagram for power terminals on ATV71H C40N4, C50N4, C40Y, C50Y, C63Y drives

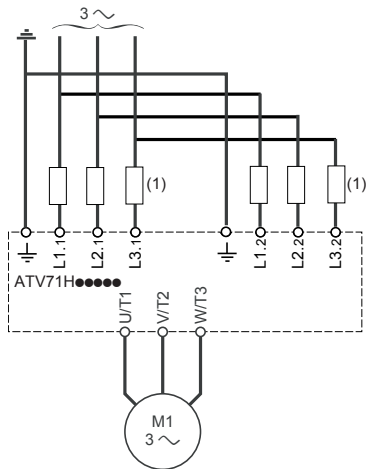

(1) Line chokes, optional for ATV71H●●●N4, compulsory for ATV71H●●●Y (to be ordered separately) if a special transformer is not used (e.g., 12-pulse).

## Braking resistor connection diagram

**ATV71H D55M3X, D75M3**  
**ATV71H D90N4 to C16N4**  
**ATV71H C11Y to C16Y**

For these ratings, braking resistors are connected directly to the terminals at the base of the drive (terminals PA and PB).

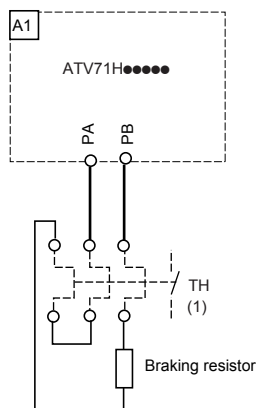

(1) Thermal overload relay

**ATV71H C20N4 to C50N4**  
**ATV71H C20Y to C63Y**

For these ratings, the braking resistor is connected on the external braking unit. Please refer to the braking unit User's Manual.

# Connection diagrams

## Control connection diagrams

### Control card connection diagram

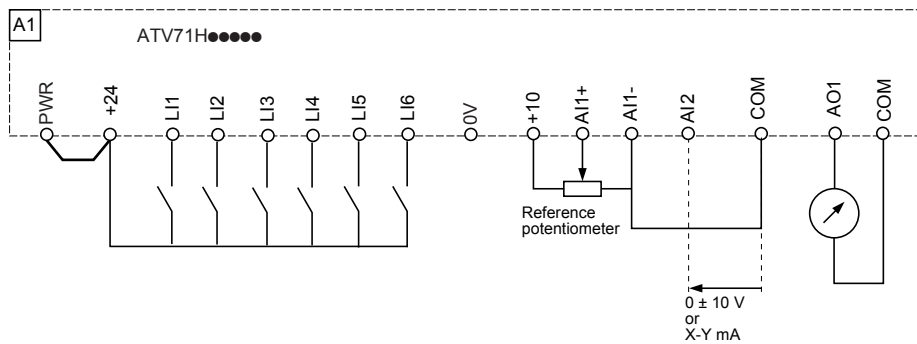

### Logic input switch (SW1)

The logic input switch (SW1) is used to adapt the operation of the logic inputs to the technology of the programmable controller outputs.

- Set the switch to Source (factory setting) if using PLC outputs with PNP transistors.
- Set the switch to Sink Int or Sink Ext if using PLC outputs with NPN transistors.

- Switch SW1 set to "Source" position

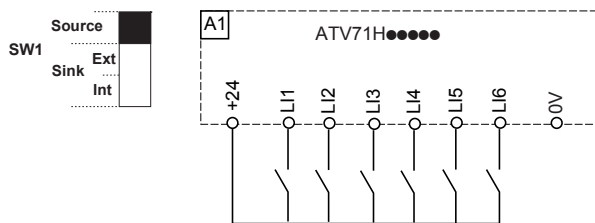

- Switch SW1 set to "Source" position and use of an external power supply for the LIs

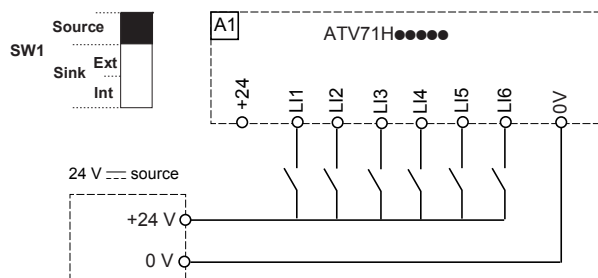

- Switch SW1 set to "Sink Int" position

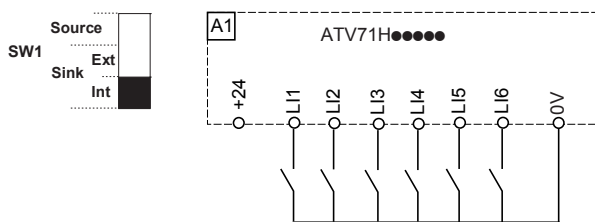

- Switch SW1 set to "Sink Ext" position

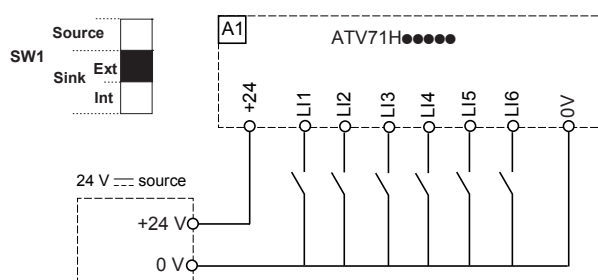

## WARNING

### UNINTENDED EQUIPMENT OPERATION

When switch SW1 is set to "Sink Int" or "Sink Ext", the common must never be connected to ground or to protective ground, as there is then a risk of unintended equipment operation on the first insulation fault.

**Failure to follow this instruction can result in death, serious injury or equipment damage.**



# Connection diagrams

## Bipolar speed reference

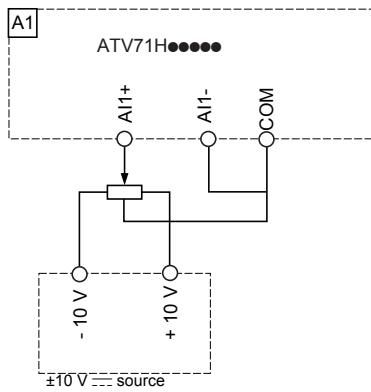

## Speed reference using axis control

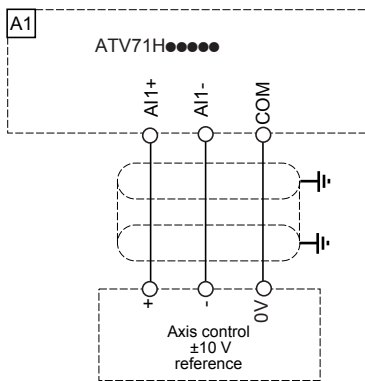

## Switch SW2

The LI6 logic input switch (SW2) makes it possible to use the LI6 input:

- Either as a logic input by setting the switch to LI (factory setting)
- Or for motor protection via PTC probes by setting the switch to PTC

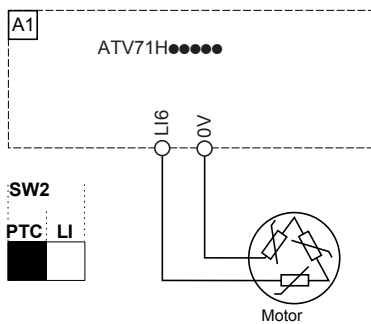

## Control power supply via an external source

The control card can be supplied via an external +24 V source

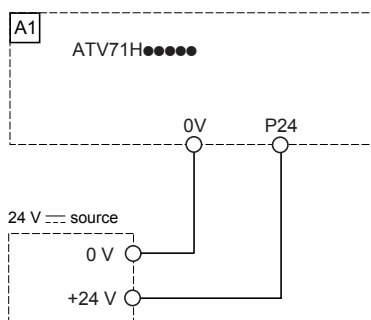

# Connection diagrams

## I/O extension card connection diagrams

Connection diagram for extended I/O option card (VW3A3202)

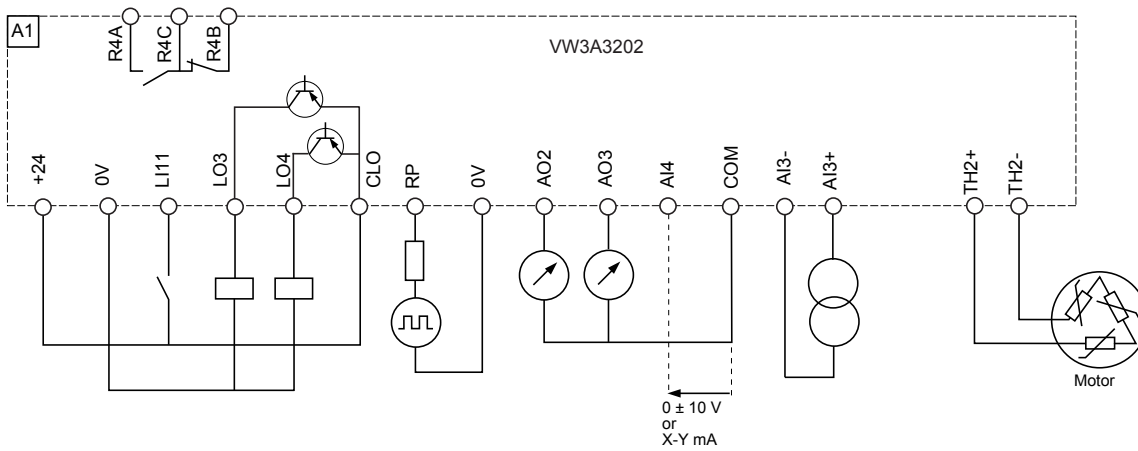

Connection diagram for logic I/O option card (VW3A3201)

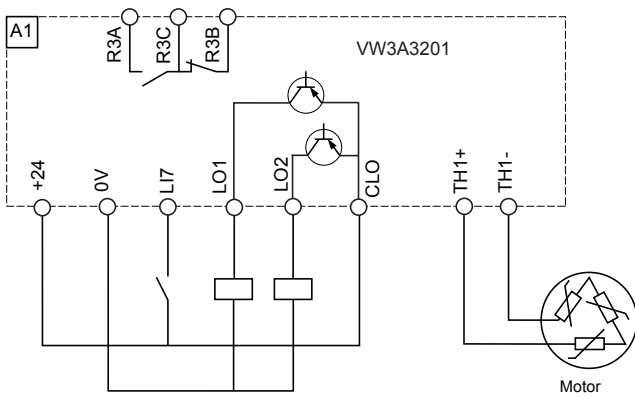

# Connection diagrams

## SW3/SW4 logic I/O switch

- Switch in "Source" position

SW3 or SW4

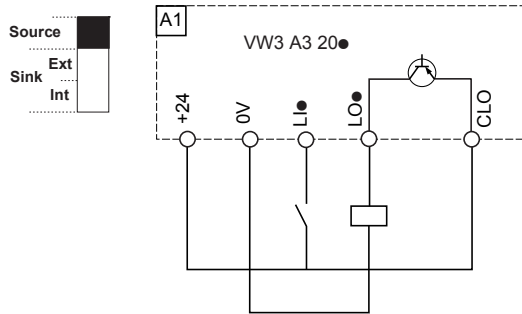

- Switch in "Source" position and use of an external + 24 V source

SW3 or SW4

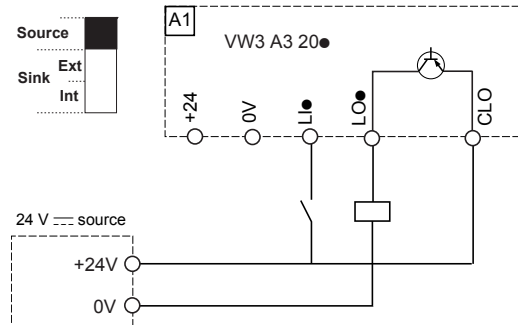

- Switch in "Sink Int" position

SW3 or SW4

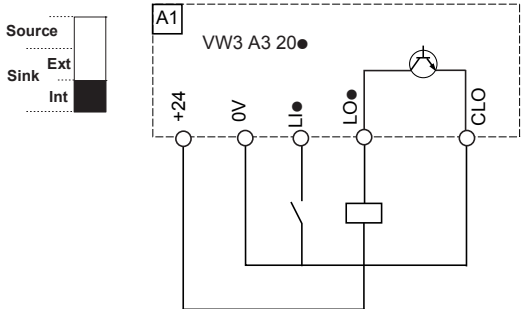

- Switch in "Sink Ext" position

SW3 or SW4

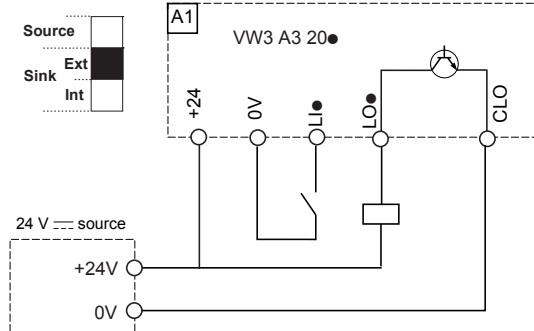

## WARNING

### UNINTENDED EQUIPMENT OPERATION

When switches SW3 or SW4 are set to "Sink Int" or "Sink Ext", the common must never be connected to ground or to protective ground, as there is then a risk of unintended equipment operation on the first insulation fault.

**Failure to follow this instruction can result in death, serious injury or equipment damage.**

# Connection diagrams

## Connection of several drives in parallel on the DC bus

It is essential that these drives all have the same voltage rating.

### Connection on DC bus between drives with equivalent ratings

Each drive uses its own charging circuit

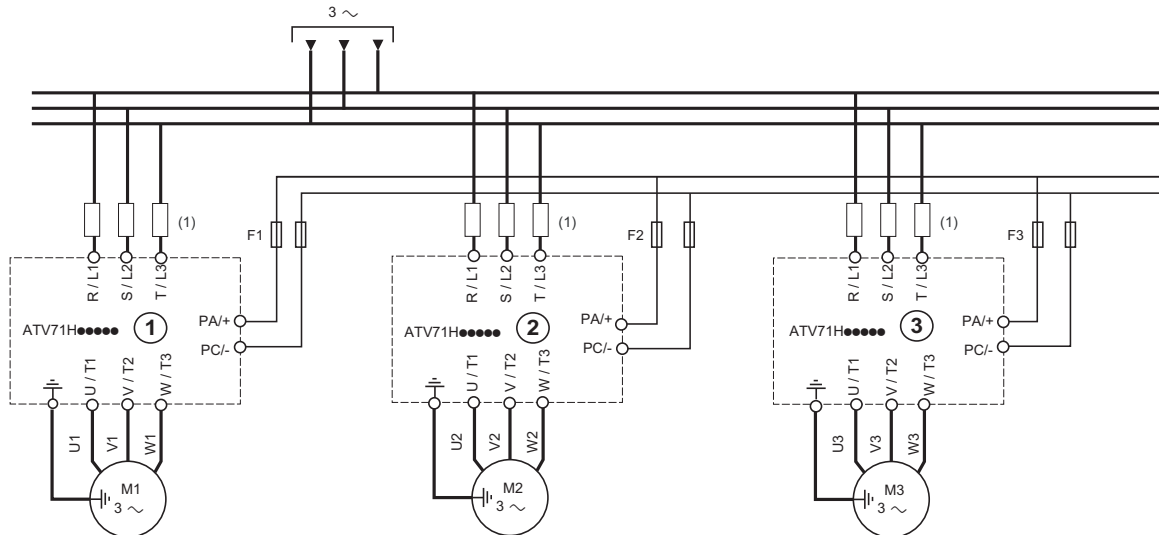

Drives ①, ② and ③ must not be more than one size apart when they are connected in this way.

F1, F2, F3: Fast-acting semiconductor fuses for protection on the DC bus side.

### Connection on DC bus between drives with different ratings

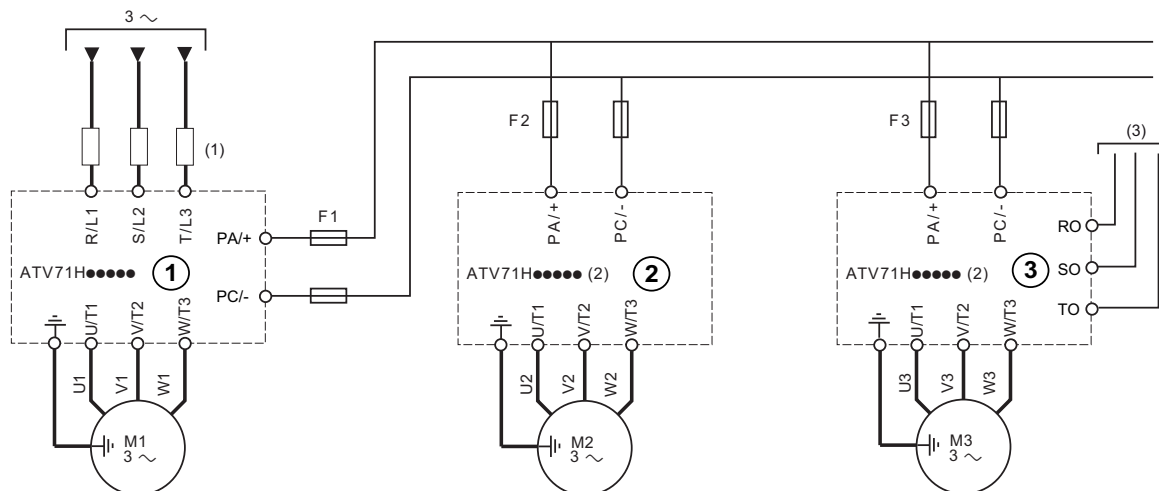

(1) Line choke, optional for ATV71H●●●M3X and ATV71H●●●N4, compulsory for ATV71H●●●Y (to be ordered separately) if a special transformer is not used (e.g., 12-pulse).

(2) Drives ② and Catalog number ③ powered only by their DC bus do not have to have a DC choke (catalog number ATV71H●●●M3XD or ATV71H●●●N4D).

(3) Separate fan power supply for certain ratings, please refer to the warning below.

F1, F2, F3: Fast-acting semiconductor fuses for protection on the DC bus side.

## ⚠ CAUTION

### RISK OF DAMAGE TO DRIVES

- Drive 1 must be large enough to supply all the motors capable of operating simultaneously.
  - When ratings D75M3X, C11N4 to C50N4 and C11Y to C63Y (drive 3 in the diagram above) are powered only by their DC bus and not their R/L1, S/L2, T/L3 terminals, it is essential to provide a separate three-phase power supply 380...480 V, 50 / 60 Hz (RO, SO, TO terminals) for the fans, protected with fuses or a motor disconnect. Power and connection are detailed on the following page.
- Failure to follow these instructions can result in injury and/or equipment damage.**

# Connection diagrams

## Power consumed by the fans

ATV71H drive	Power consumed by the fans
D75M3X, C11N4, C13N4, C16N4, C11Y, C13Y, C16Y	550 VA
C20N4, C25N4, C28N4, C20Y, C25Y, C31Y	1,100 VA
C31N4, C40N4, C50N4, C40Y, C50Y, C63Y	2,200 VA

## Connecting fans for a separate power supply

In order to remove the link between the fans and power supply terminals R/L1, S/L2, T/L3 and relocate it at terminals RO, SO, TO, connectors X1 and X4 must be crossed as indicated on the diagrams below.

### ATV71H D75M3X, C11N4 to C16N4 and C11Y to C16Y

Factory wiring: Fans powered internally by R/L1, S/L2, T/L3

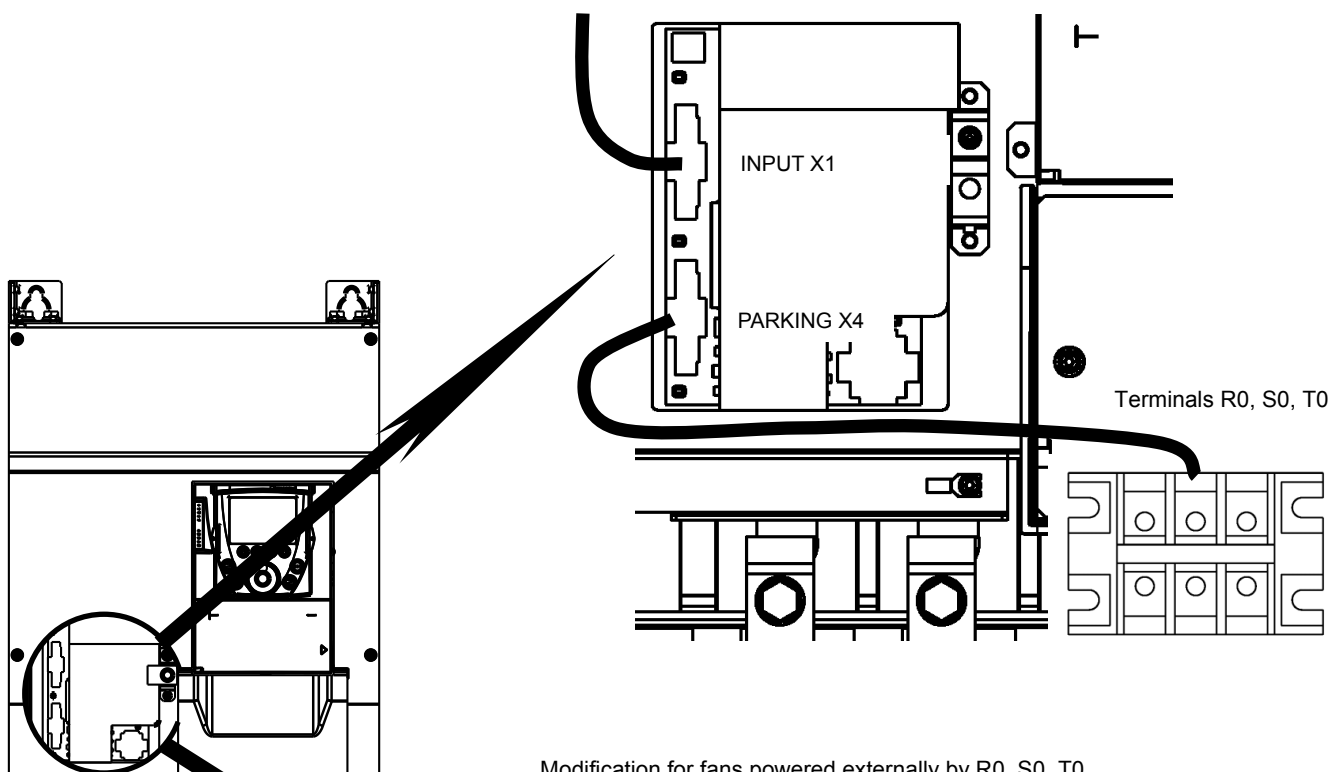

Modification for fans powered externally by R0, S0, T0

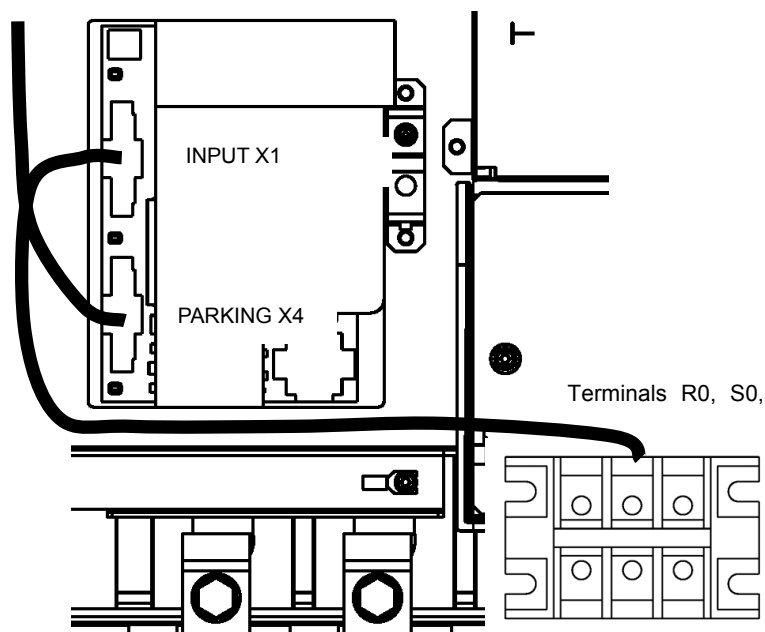

# Connection diagrams

## ATV71H C20N4 to C28N4 and C20Y to C31Y

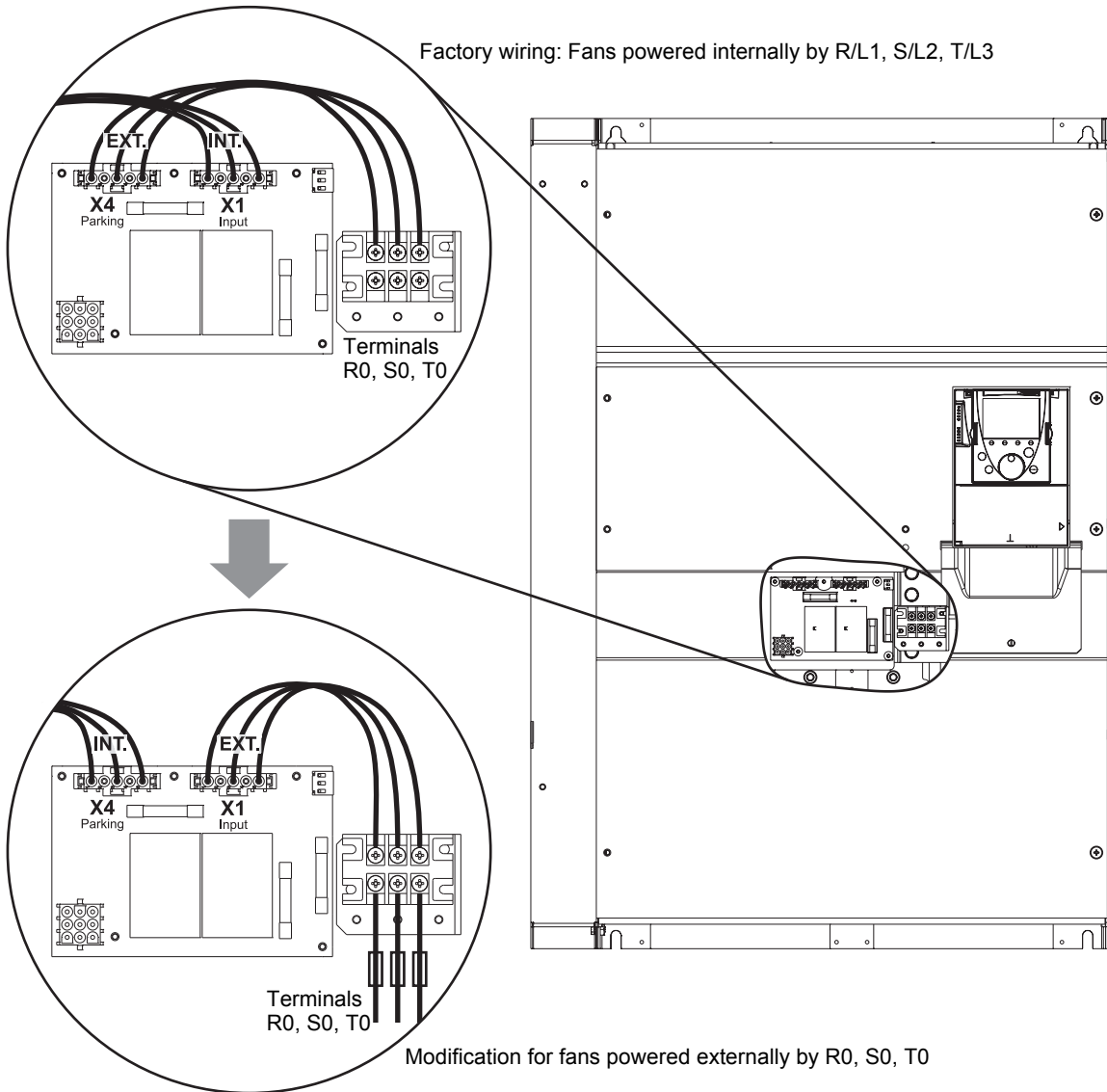

# Connection diagrams

## ATV71H C31N4, C40N4

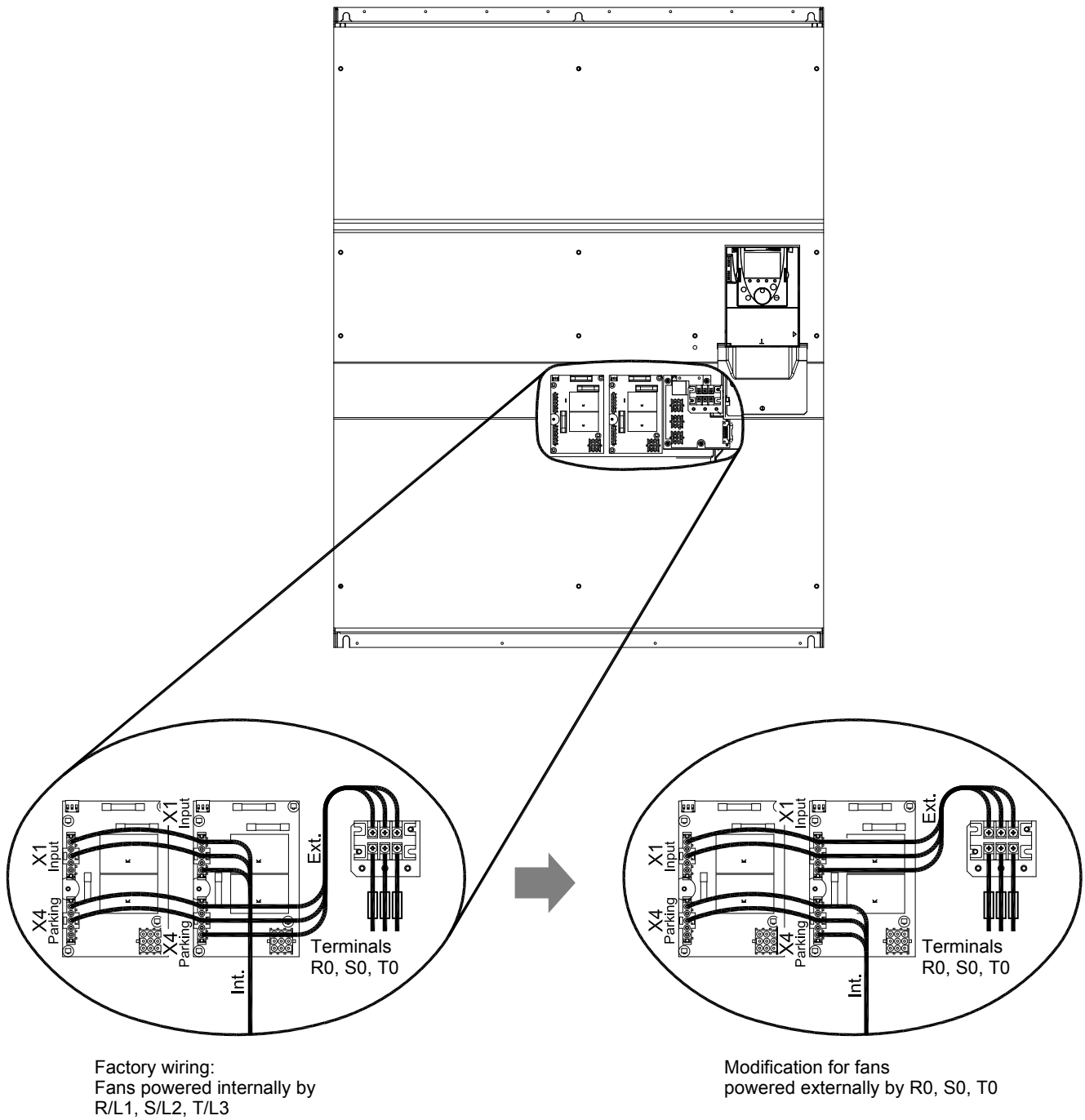

# Connection diagrams

## ATV71H C50N4, C40Y to C63Y

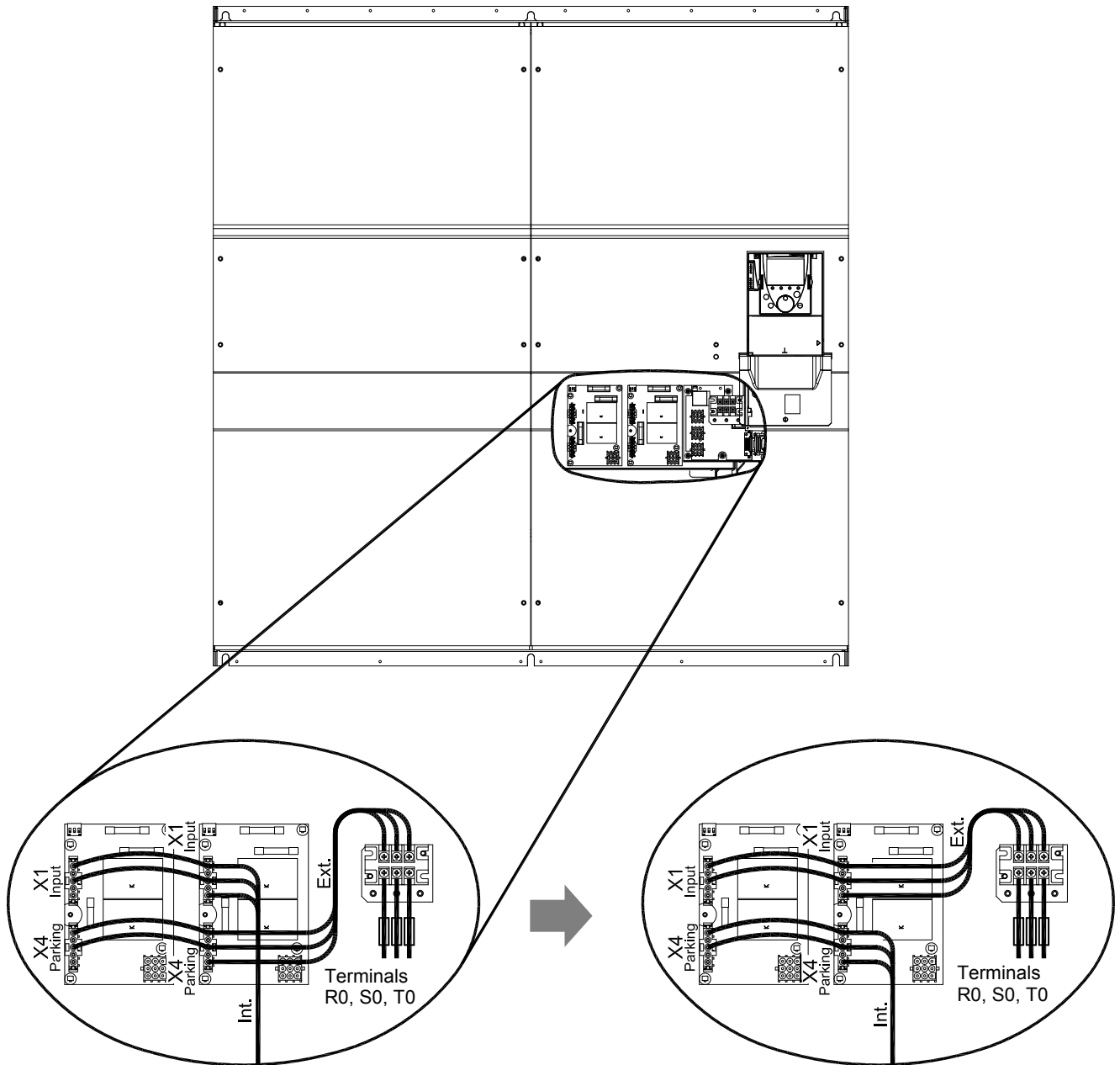

Factory wiring:  
Fans powered internally by  
R/L1, S/L2, T/L3

Modification for fans  
powered externally by R0, S0, T0



# Use on an IT system and corner grounded system

**IT system:** Isolated or impedance grounded neutral system.

Use a permanent insulation monitor compatible with non-linear loads such as a Merlin Gerin type XM200 or equivalent.

Altivar 71 drives feature built-in RFI filters. In order to be able to use ATV71H C11Y to C63Y drives on an IT system, the link between these filters and ground must be removed as shown in the connection diagrams below. For other drives, removal of the link is possible but not mandatory:

**Corner grounded system:** System with one phase grounded.

 <b>WARNING</b>
<b>RISK OF ELECTRIC SHOCK</b>
ATV71H C11Y to C63Y drives must not be connected on a corner grounded system.
<b>Failure to follow this instruction can result in death, serious injury or equipment damage.</b>

## Disconnection of RFI filters

**ATV71H D90N4 to C11N4:**

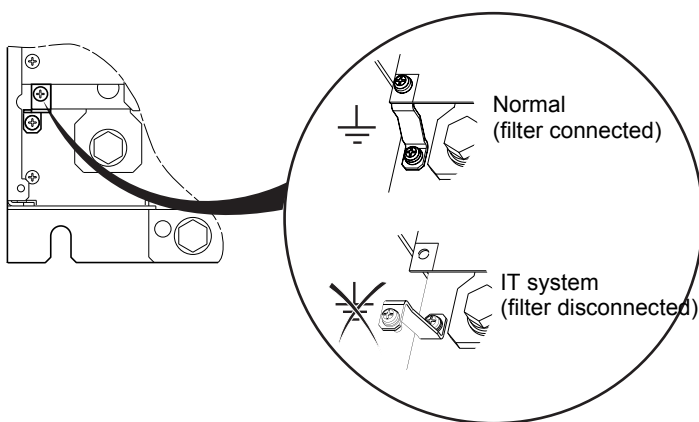

**ATV71H C13N4 to C16N4 and ATV71H C11Y to C16Y:**

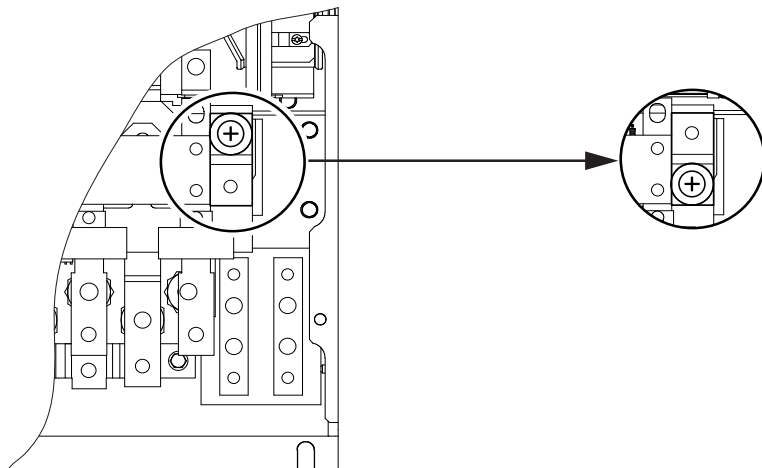
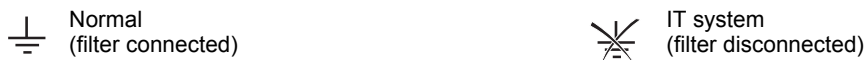

 <b>CAUTION</b>
<b>RISK OF DAMAGE TO DRIVE</b>
The filter must be disconnected if the drive is to be used on an IT or corner grounded system.
<b>Failure to follow this instruction can result in injury and/or equipment damage.</b>

# Use on an IT system and corner grounded system

ATV71H C20N4 to C28N4 and ATV71H C20Y to C31Y:

Normal  
(filter connected)

IT system  
(filter disconnected)

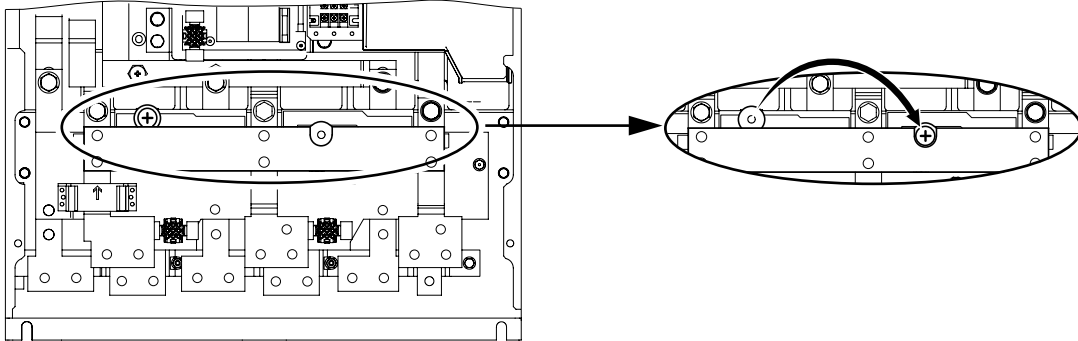

ATV71HC31N4:

Normal  
(filter connected)

IT system  
(filter disconnected)

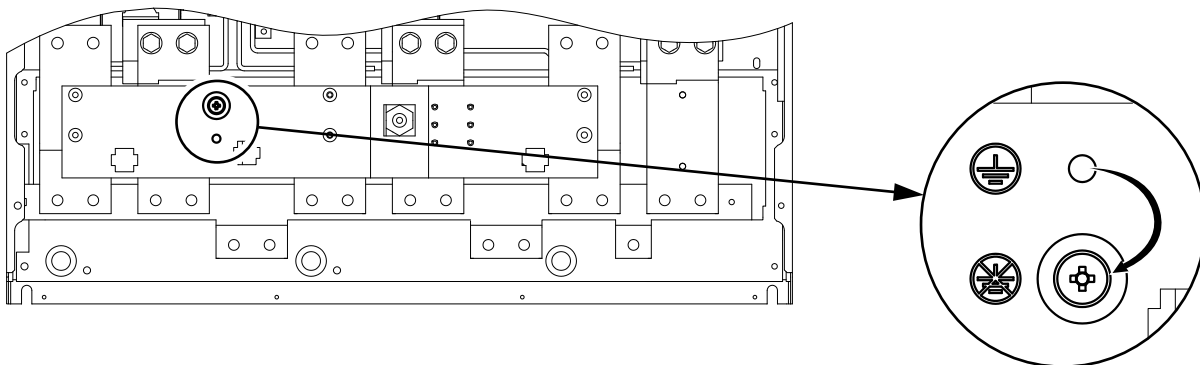

## ⚠ CAUTION

### RISK OF DAMAGE TO DRIVE

The filter must be disconnected if the drive is to be used on an IT or corner grounded system.  
**Failure to follow this instruction can result in injury and/or equipment damage.**

# Use on an IT system and corner grounded system

## ATV71HC40N4:

 Normal  
(filter connected)

 IT system  
(filter disconnected)

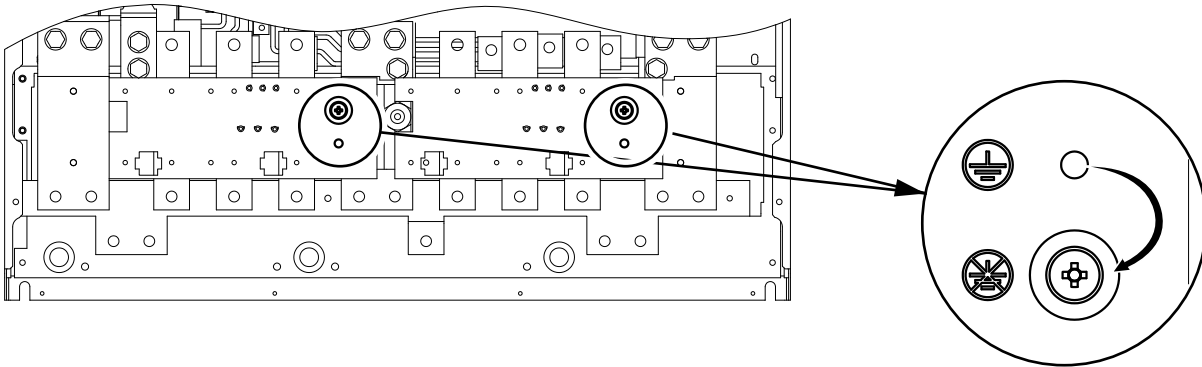

## ATV71H C50N4 and ATV71H C40Y to C63Y:

 Normal  
(filter connected)

 IT system  
(filter disconnected)

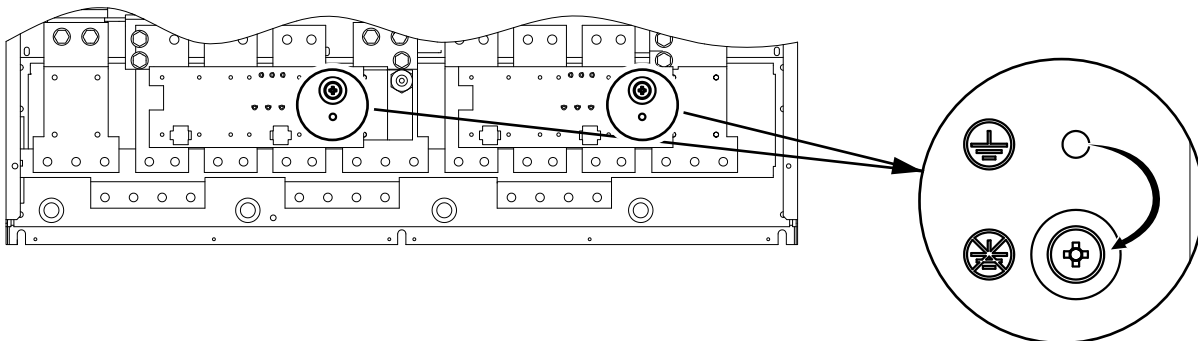

### CAUTION

#### RISK OF DAMAGE TO DRIVE

The filter must be disconnected if the drive is to be used on an IT or corner grounded system.  
**Failure to follow this instruction can result in injury and/or equipment damage.**

# Electromagnetic compatibility, wiring

## Electromagnetic compatibility

### Principle

- Grounds between drive, motor and cable shielding must have "high frequency" equipotentiality.
- Use of shielded cables with shielding connected to ground at both ends for the motor cables, braking resistor (if used) and control-signal wiring. Metal ducting or conduit can be used for part of the shielding length provided that there is no break in continuity.
- Ensure maximum separation between the power cable (line supply) and the motor cable.

### Installation diagram

ATV71H D55M3X to D75M3X, ATV71H D90N4 to C50N4 and ATV71H C11Y to C63Y

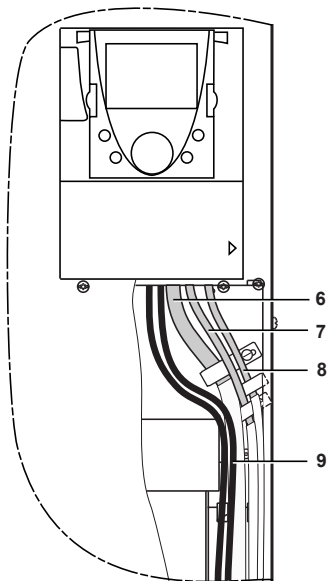
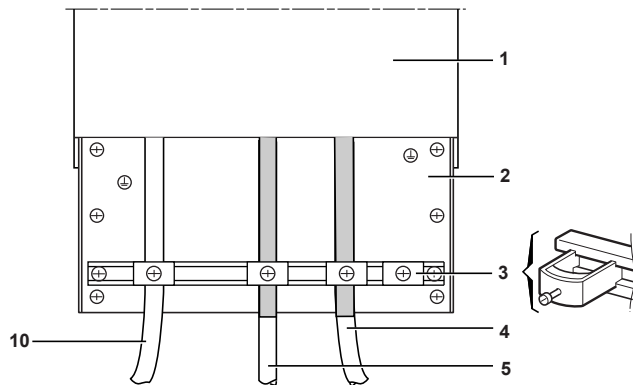

- 1 Altivar 71
- 2 Sheet steel grounded plate
- 3 Metal clamps
- 4 Shielded cable for motor connection, with shielding connected to ground at both ends. The shielding must be continuous and intermediate terminals must be in EMC shielded metal boxes.
- 5 Shielded cable for connecting the braking resistor (if used). The shielding must be continuous and intermediate terminals must be in EMC shielded metal boxes.
- 6 Shielded cables for connecting the control-signal cables. For applications requiring several conductors, use cables with a small cross-section (0.5 mm<sup>2</sup>).
- 7 Shielded cables for connecting the Power Removal safety function input. The shielding must be continuous and intermediate terminals must be in EMC shielded metal boxes.
- 8 Shielded cables for connecting the encoder. The shielding must be continuous and intermediate terminals must be in EMC shielded metal boxes.
- 9 Unshielded wires for relay contact output.
- 10 Unshielded drive power supply cables.

### Note:

- If using an additional input filter, it should be connected directly to the line supply via an unshielded cable. Link **10** on the drive is made via the filter output cable.
- The HF equipotential ground connection between the drive, motor and cable shielding does not remove the need to connect the PE protective conductors (green-yellow) to the appropriate terminals on each unit.

# Electromagnetic compatibility, wiring

## Installing the encoder cable for the VW3 A3 408, VW3 A3 409 and VW3 A3 411 cards (1 cable)

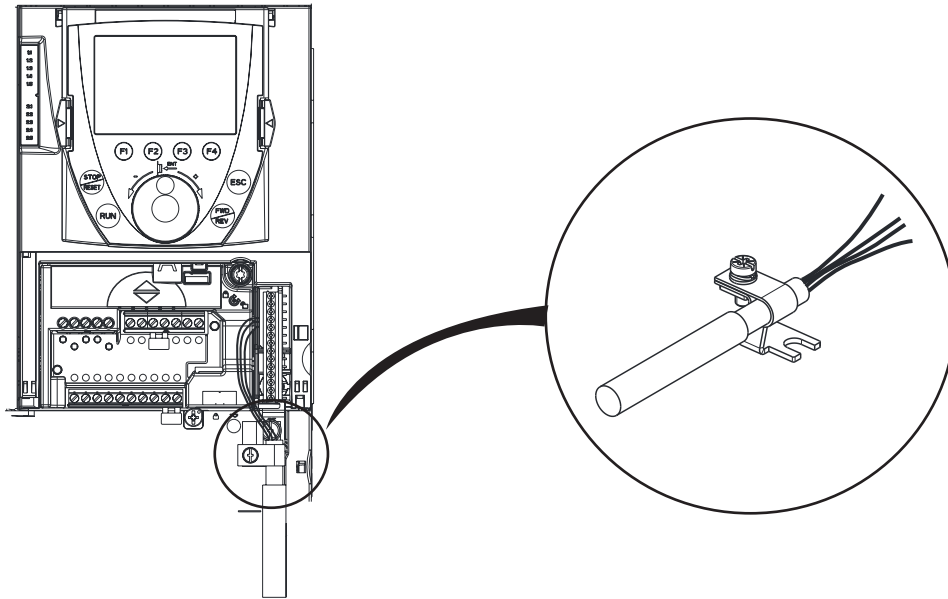

- 1 Strip the cable shielding.
- 2 Select the appropriate clamp for the cable diameter and attach it to the cable.
- 3 Attach the clamp to the bracket using one of the screws supplied with the card.
- 4 Use the ground screw to attach the bracket to the grounding point located next to the encoder card.

### Note:

The cable must be mounted on the EMC plate as shown in the diagram on page [76](#). The cable must be stripped for mounting on the EMC plate.

## Installing the ESIM and encoder cables for the VW3 A3 411 card (2 cables)

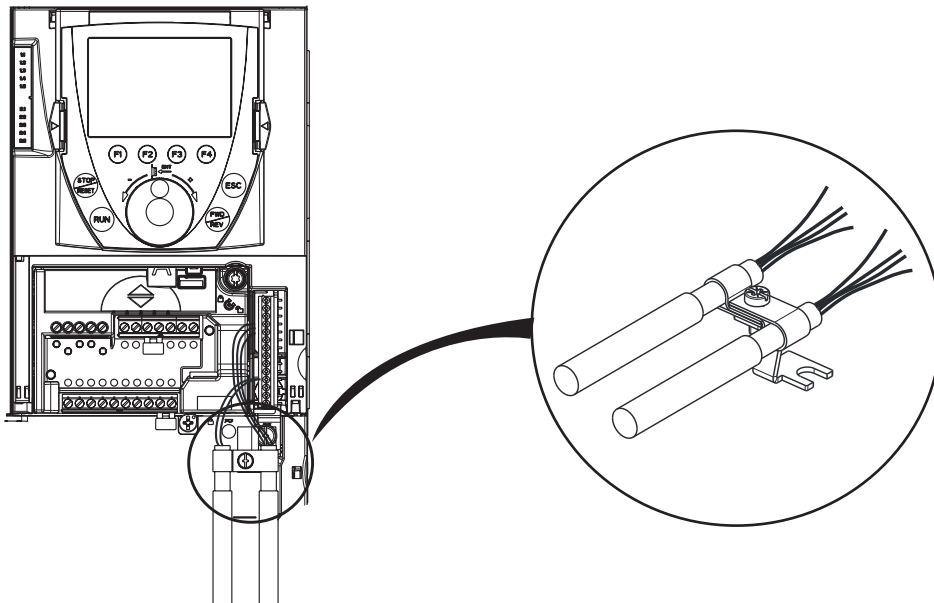

- Repeat steps 1 to 4 above.
- 5 Strip the shielding from the ESIM cable.
  - 6 Attach the clamp to the cable.
  - 7 Attach the clamp to the bracket using the second screw supplied with the card.

