



INVERTER

FR-F800

INSTALLATION GUIDELINE

FR-F820-00046(0.75K) to 04750(110K)

FR-F840-00023(0.75K) to 06830(315K)

Thank you for choosing this Mitsubishi Electric Inverter.
This Installation guideline and the enclosed CD-ROM give handling information and precautions for use of this product.
Do not use this product until you have a full knowledge of the equipment, the safety information and the instructions.
Please forward this Installation guideline and the CD-ROM to the end user.

CONTENTS

[1]	INSTALLATION AND INSTRUCTIONS.....	1
[2]	OUTLINE DRAWING	3
[3]	WIRING	4
[4]	FAILSAFE OF THE SYSTEM WHICH USES THE INVERTER.....	20
[5]	PRECAUTIONS FOR USE OF THE INVERTER	21
[6]	DRIVE THE MOTOR	23
[7]	TROUBLESHOOTING	39
[8]	SPECIFICATIONS	42
[A]	APPENDIX	44



Version check

Art. No.: 281590
20 11 2014
Version A

This section is specifically about safety matters

Do not attempt to install, operate, maintain or inspect the inverter until you have read through this Installation Guideline and appended documents carefully and can use the equipment correctly. Do not use the inverter until you have a full knowledge of the equipment, safety information and instructions.

Installation, operation, maintenance and inspection must be performed by qualified personnel. Here, qualified personnel means personnel who meets all the conditions below.

- A person who took a proper engineering training. Please note if you can take a proper engineering training at your local Mitsubishi Electric office. Such training may be available at your local Mitsubishi Electric office. Contact your local sales office for schedules and locations.
- A person who can access operating manuals for the protective devices (e.g. light curtain) connected to the safety control system.

A person who has read and familiarized himself/herself with the manuals.

In this Installation Guideline, the safety instruction levels are classified into "WARNING" and "CAUTION".

WARNING

Assumes that incorrect handling may cause hazardous conditions, resulting in death or severe injury.

CAUTION

Assumes that incorrect handling may cause hazardous conditions, resulting in medium or slight injury, or may cause physical damage only.

Note that even the  **CAUTION** level may lead to a serious consequence according to conditions. Please follow strictly the instructions of both levels because they are important to personnel safety.

Electric Shock Prevention

WARNING

- While power is on or when the inverter is running, do not open the front cover. Otherwise you may get an electric shock.
- Do not run the inverter with the front cover removed. Otherwise, you may access the exposed high-voltage terminals or the charging part of the circuitry and get an electric shock.
- Even if power is off, do not remove the front cover except for wiring or periodic inspection. You may access the charged inverter circuits and get an electric shock.
- Before starting wiring or inspection, check to make sure that the operation panel indicator is off, wait for at least 10 minutes after the power supply has been switched off, and check that there are no residual voltage using a tester or the like. The capacitor is charged with high voltage for some time after power off and it is dangerous.
- This inverter must be earthed. Earthing must conform to the requirements of national and local safety regulations and electrical codes (JIS, NEC section 250, IEC 536 class 1 and other applicable standards). A neutral-point earthed power supply for 400V class inverter in compliance with EN standard must be used.
- Any person who is involved in the wiring or inspection of this equipment should be fully competent to do the work.
- Always install the inverter before wiring. Otherwise, you may get an electric shock or be injured.
- If your application requires by installation standards an RCD (residual current device) as up stream protection please select according to DIN VDE 0100-530 as following:
 - Single phase inverter type A or B
 - Three phase inverter only type B(Additional instructions on the use of a residual current device are contained on *page 45*.)
- Perform setting dial and key operations with dry hands to prevent an electric shock. Otherwise you may get an electric shock.
- Do not subject the cables to scratches, excessive stress, heavy loads or pinching. Otherwise you may get an electric shock.
- Do not replace the cooling fan while power is on. It is dangerous to replace the cooling fan while power is on.
- Do not touch the printed circuit board or handle the cables with wet hands. You may get an electric shock.
- When measuring the main circuit capacitor capacity, the DC voltage is applied to the motor for 1s at powering OFF. Never touch the motor terminal, etc. right after powering OFF to prevent an electric shock.
- A PM motor is a synchronous motor with high-performance magnets embedded in the rotor. Motor terminals holds high-voltage while the motor is running even after the inverter power is turned OFF. Before wiring or inspection, the motor must be confirmed to be stopped. In an application, such as fan and blower, where the motor is driven by the load, a low-voltage manual motor starter must be connected at the inverter's output side, and wiring and inspection must be performed while the motor starter is open. Otherwise you may get an electric shock.

Fire Prevention

CAUTION

- Mount the inverter to incombustible material. Install the inverter on a nonflammable wall without holes (so that nobody can touch the inverter heatsink on the rear side, etc.). Mounting it to or near combustible material can cause a fire.
- If the inverter has become faulty, switch off the inverter power. A continuous flow of large current could cause a fire.
- Do not connect a resistor directly to the DC terminals P/+, N/-. This could cause a fire and destroy the inverter. The surface temperature of braking resistors can far exceed 100 °C for brief periods. Make sure that there is adequate protection against accidental contact and a safe distance is maintained to other units and system parts.
- Be sure to perform daily and periodic inspections as specified in the Instruction Manual. If a product is used without any inspection, a burst, breakage, or a fire may occur.

Injury Prevention

⚠CAUTION

- Apply only the voltage specified in the instruction manual to each terminal. Otherwise, burst, damage, etc. may occur.
- Ensure that the cables are connected to the correct terminals. Otherwise, burst, damage, etc. may occur.
- Always make sure that polarity is correct to prevent damage, etc. Otherwise, burst, damage, etc. may occur.
- While power is on or for some time after power-off, do not touch the inverter as it is hot and you may get burnt.

Additional Instructions

Also note the following points to prevent an accidental failure, injury, electric shock, etc.

Transportation and installation

⚠CAUTION

- Any person who is opening a package using a sharp object, such as a knife and cutter, must wear gloves to prevent injuries caused by the edge of the sharp object.
- When carrying products, use correct lifting gear to prevent injury.
- Do not stand or rest heavy objects on the product.
- Do not stack the inverter boxes higher than the number recommended.
- When carrying the inverter, do not hold it by the front cover or setting dial; it may fall off or fail.
- During installation, caution must be taken not to drop the inverter as doing so may cause injuries.
- Ensure that installation position and material can withstand the weight of the inverter. Install according to the information in the instruction manual.
- Do not install the product on a hot surface.
- Check the inverter mounting orientation is correct.
- The inverter must be installed on a strong surface securely with screws so that it will not drop.
- Do not install or operate the inverter if it is damaged or has parts missing. This can result in breakdowns.
- Prevent other conductive bodies such as screws and metal fragments or other flammable substance such as oil from entering the inverter.
- As the inverter is a precision instrument, do not drop or subject it to impact.
- Use the inverter under the following environmental conditions. Otherwise, the inverter may be damaged.

Operating condition	FR-F800
Surrounding air temperature	LD rating: -10°C to $+50^{\circ}\text{C}$ (non-freezing) SLD rating: -10°C to $+40^{\circ}\text{C}$ (non-freezing)
Ambient humidity	With circuit board coating (conforming to IEC 60721-3-3 3C2/3S2): 95% RH or less (non-condensing), Without circuit board coating: 90% RH or less (non-condensing)
Storage temperature	-20°C to $+65^{\circ}\text{C}$ *1
Atmosphere	Indoors (free from corrosive gas, flammable gas, oil mist, dust and dirt)
Altitude	Maximum 1000m above sea level for standard operation. After that derate by 3% for every extra 500m up to 2500m (91%)
Vibration	5.9m/s^2 or less *2 at 10 to 55Hz (directions of X, Y, Z axes)

*1 Temperature applicable for a short time, e.g. in transit.

*2 2.9m/s^2 or less for the FR-F840-04320(185K) or higher

- If halogen-based materials (fluorine, chlorine, bromine, iodine, etc.) infiltrate into a Mitsubishi Electric product, the product will be damaged. Halogen-based materials are often included in fumigant, which is used to sterilize or disinfect wooden packages. When packaging, prevent residual fumigant components from being infiltrated into Mitsubishi Electric products, or use an alternative sterilization or disinfection method (heat disinfection, etc.) for packaging. Sterilization or disinfection of wooden package should also be performed before packaging the product.
- To prevent a failure, do not use the inverter with a part or material containing halogen flame retardant including bromine.

Wiring

⚠CAUTION

- Do not install assemblies or components (e. g. power factor correction capacitors) on the inverter output side, which are not approved from Mitsubishi Electric. These devices on the inverter output side may be overheated or burn out.
- The direction of rotation of the motor corresponds to the direction of rotation commands (STF/STR) only if the phase sequence (U, V, W) is maintained.
- PM motor terminals (U, V, W) hold high-voltage while the PM motor is running even after the power is turned OFF. Before wiring, the PM motor must be confirmed to be stopped. Otherwise you may get an electric shock.
- Never connect a PM motor to the commercial power supply.
Applying the commercial power supply to input terminals (U,V, W) of a PM motor will burn the PM motor. The PM motor must be connected with the output terminals (U, V, W) of the inverter.

Test operation and adjustment

⚠CAUTION

- Before starting operation, confirm and adjust the parameters. A failure to do so may cause some machines to make unexpected motions.

Operation

WARNING

- When you have chosen the retry function, stay away from the equipment as it will restart suddenly after an alarm stop.
- Since pressing the  key may not stop output depending on the function setting status, provide a circuit and switch separately to make an emergency stop (power off, mechanical brake operation for emergency stop, etc).
- Make sure that the start signal is off before resetting the inverter alarm. A failure to do so may restart the motor suddenly.
- Do not use a PM motor for an application where the PM motor is driven by its load and runs at a speed higher than the maximum motor speed.
- The inverter can be started and stopped via the serial port communications link or the field bus. However, please note that depending on the settings of the communications parameters it may not be possible to stop the system via these connections if there is an error in the communications system or the data line. In configurations like this it is thus essential to install additional safety hardware that makes it possible to stop the system in an emergency (e.g. controller inhibit via control signal, external motor contactor etc). Clear and unambiguous warnings about this must be posted on site for the operating and service staff.
- Use this inverter only with three-phase induction motors or with a PM motor. Connection of any other electrical equipment to the inverter output may damage the inverter as well as the equipment.
- Do not modify the equipment.
- Do not perform parts removal which is not instructed in this manual. Doing so may lead to fault or damage of the inverter.

CAUTION

- The electronic thermal relay function does not guarantee protection of the motor from overheating. It is recommended to install both an external thermal and PTC thermistor for overheat protection.
- Do not use a magnetic contactor on the inverter input for frequent starting/stopping of the inverter. Otherwise, the life of the inverter decreases.
- Use a noise filter to reduce the effect of electromagnetic interference and follow the accepted EMC procedures for proper installation of frequency inverters. Otherwise nearby electronic equipment may be affected.
- Take appropriate measures regarding harmonics. Otherwise this can endanger compensation systems or overload generators.
- When driving a 400V class motor by the inverter, the motor must be an insulation-enhanced motor or measures must be taken to suppress surge voltage. Surge voltage attributable to the wiring constants may occur at the motor terminals, deteriorating the insulation of the motor.
- Use a motor designed for inverter operation. (The stress for motor windings is bigger than in line power supply).
- When parameter clear or all clear is performed, set again the required parameters before starting operations. Each parameter returns to the initial value.
- The inverter can be easily set for high-speed operation. Before changing its setting, fully examine the performances of the motor and machine.
- The DC braking function of the frequency inverter is not designed to continuously hold a load. Use an electro-mechanical holding brake on the motor for this purpose.
- Before running an inverter which had been stored for a long period, always perform inspection and test operation.
- For prevention of damage due to static electricity, touch nearby metal before touching this product to eliminate static electricity from your body.
- Only one PM motor can be connected to an inverter.
- A PM motor must be used under PM motor control. When operating with PM motor control, a synchronous motor, induction motor or synchronous induction motor may only be used when it is a PM motor.
- Do not connect a PM motor under the induction motor control settings (initial settings). Do not use an induction motor under the PM motor control settings. It will cause a failure.
- In the system with a PM motor, the inverter power must be turned ON before closing the contacts of the contactor at the output side.
- When the emergency drive operation is performed, the operation is continued or the retry is repeated even when a fault occurs, which may damage or burn the inverter and motor. Before restarting the normal operation after using the emergency drive function, make sure that the inverter and motor have no fault.

Emergency stop

CAUTION

- Provide a safety backup such as an emergency brake which will prevent the machine and equipment from hazardous conditions if the inverter fails.
- When the breaker on the inverter primary side trips, check for the wiring fault (short circuit), damage to internal parts of the inverter, etc. Identify the cause of the trip, then remove the cause and power on the breaker.
- When the protective function is activated (i. e. the frequency inverter switches off with an error message), take the corresponding corrective action as described in the inverter manual, then reset the inverter, and resume operation.

Maintenance, inspection and parts replacement

CAUTION

- Do not carry out a megger (insulation resistance) test on the control circuit of the inverter. It will cause a failure.

Disposing of the inverter

CAUTION

- Treat as industrial waste.

General instructions

Many of the diagrams and drawings in instruction manuals show the inverter without a cover, or partially open. Never run the inverter in this status. Always replace the cover and follow instruction manuals when operating the inverter. For more details on the PM motor, refer to the Instruction Manual of the PM motor.

1 INSTALLATION AND INSTRUCTIONS

1.1 Inverter Type

FR - F820 - 00046 -1

Symbol	Voltage class	Symbol	Description	Symbol	Type ^{*1}	Symbol	Circuit board coating (conforming to IEC60721-3-3 3C2/3S2)	Plated conductor
2	200V class	00023 to 06830	SLD rated inverter current [A]	-1	FM	Without	Without	Without
4	400V class	0.75 to 315K	LD rated inverter capacity [kW]	-2	CA	-60	With	Without
						-06	With	With

Capacity plate

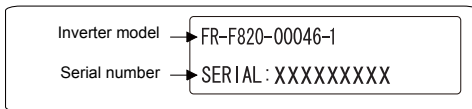

Rating plate

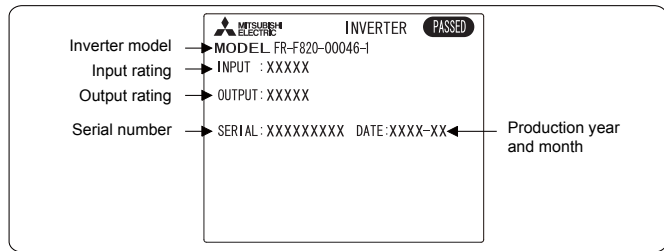

^{*1} Specification differs by the type. Major differences are shown in the table below.

Type	Monitor output	Initial setting				
		Built-in EMC filter	Control logic	Rated frequency	Pr. 19 "Base frequency voltage"	Pr.570 "Multiple rating setting"
FM (terminal FM equipped model)	Terminal FM: pulse train output Terminal AM: analog voltage output (0 to ±10VDC)	OFF	Sink logic	60Hz	9999 (same as the power supply voltage)	1 (LD rating)
CA (terminal CA equipped model)	Terminal CA: analog current output (0 to 20mADC) Terminal AM: analog voltage output (0 to ±10VDC)	ON	Source logic	50Hz	8888 (95% of the power supply voltage)	0 (SLD rating)

Notes

- The rating plate shows the rated inverter current in SLD operation (Super Light Duty). The overload current rating at SLD is 110 % of the rated current for 60 s and 120 % for 3 s at surrounding air temperature of max. 40 °C.
- The inverter model name used in this installation guide consists of the inverter model, e. g. FR-F820-00046-1 and the applicable motor capacity in brackets specified in [kW]. This approach helps for better understanding and for choosing the right motor. For further specification details like capacity, current or overload current rating refer to *chapter 8*.
- For selecting the right frequency inverter you should know details of your application and especially the load characteristic.



1.2 Installation of the inverter

Installation on the enclosure

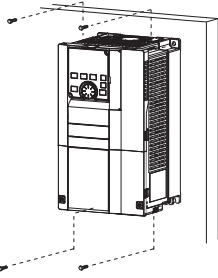

Fix six positions for the FR-F840-04320(185K) or higher.

- Install the inverter on a strong surface securely with bolts.
- Leave enough clearances and take cooling measures.
- Avoid places where the inverter is subjected to direct sunlight, high temperature and high humidity.
- Install the inverter on a nonflammable surface.
- When encasing multiple inverters, install them in parallel as a cooling measure.

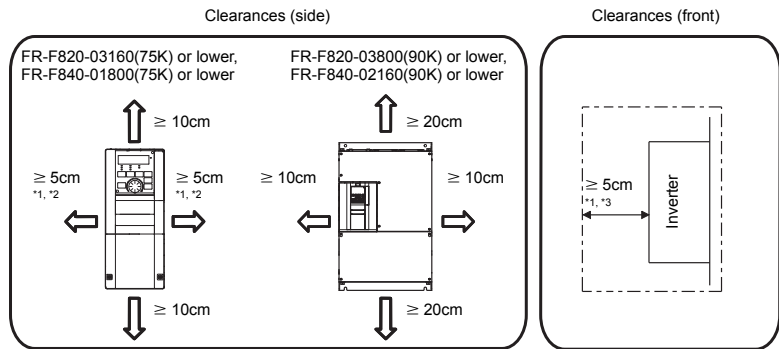
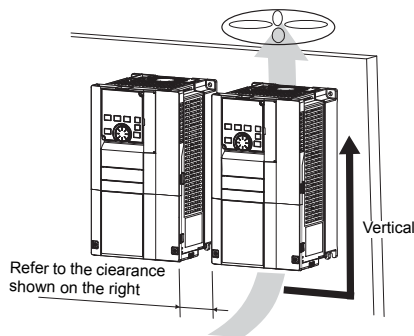

*1 For the FR-F820-00250(5.5K) or lower and FR-F840-00126(5.5K) or lower, allow 1cm or more clearance.

*2 When using the FR-F820-01250(30K) or lower and FR-F840-00620(30K) or lower at the surrounding air temperature of 40°C or less (30°C or less for the SLD rated inverter), side-by-side installation (0cm clearance) is available.

*3 For replacing the cooling fan of the FR-F840-04320(185K) or higher, 30cm of space is necessary in front of the inverter. Refer to the Instruction Manual for fan replacement.

1.3 Environment

Before installation, check that the environment meets following specifications:

Surrounding air temperature *6	LD rating: -10°C to +50°C (non-freezing)	
	SLD rating: -10°C to +40°C (non-freezing)	
Ambient humidity	With circuit board coating (conforming to IEC 60721-3-3 3C2/3S2): 95% RH or less (non-condensing), Without circuit board coating: 90% RH or less (non-condensing)	
Storage temperature	-20°C to +65°C *4	
Atmosphere	Indoors (No corrosive and flammable gases, oil mist, dust and dirt)	
Altitude	Maximum 2,500 m above sea level *5	
Vibration	5.9m/s ² or less *7 at 10 to 55Hz (directions of X, Y, Z axes)	

*4 Temperature applicable for a short time, e.g. in transit.

*5 For the installation at an altitude above 1,000m up to 2,500m, derate the rated current 3% per 500 m.

*6 Surrounding air temperature is a temperature measured at a measurement position in an enclosure. Ambient temperature is a temperature outside an enclosure.

*7 2.9m/s² or less for the FR-F840-04320(185K) or higher

2 OUTLINE DRAWING

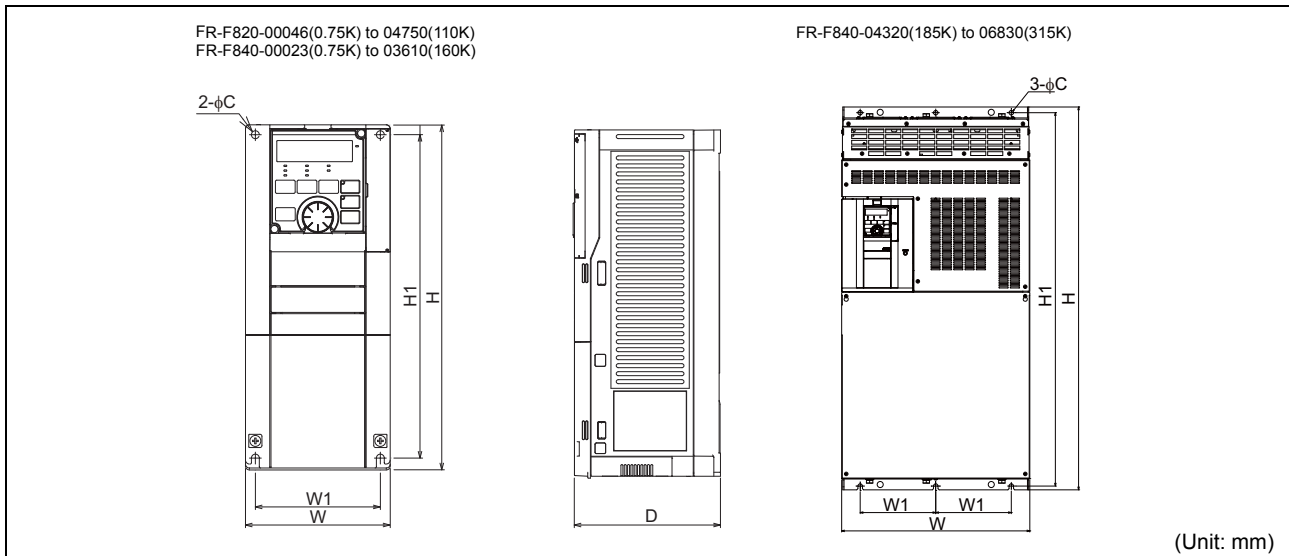

	Inverter Type	W	W1	H	H1	D	c		
200V class	FR-F820-00046(0.75K)	110	95	260	245	110	6		
	FR-F820-00077(1.5K)					125			
	FR-F820-00105(2.2K)	150	125			260		245	140
	FR-F820-00167(3.7K)								
	FR-F820-00250(5.5K)	220	195			300		285	170
	FR-F820-00340(7.5K)								
	FR-F820-00490(11K)								
	FR-F820-00630(15K)								
	FR-F820-00770(18.5K)	250	230	400	380	190	10		
	FR-F820-00930(22K)								
	FR-F820-01250(30K)								
	FR-F820-01540(37K)								
	FR-F820-01870(45K)	435	380	550	525	250	12		
	FR-F820-02330(55K)								
FR-F820-03160(75K)	465	410	700	675	360				
FR-F820-03800(90K)		400	740	715					
FR-F820-04750(110K)									
400V class	FR-F840-00023(0.75K)	150	125	260	245	140	6		
	FR-F840-00038(1.5K)								
	FR-F840-00052(2.2K)								
	FR-F840-00083(3.7K)								
	FR-F840-00126(5.5K)								
	FR-F840-00170(7.5K)	220	195	300	285	170			
	FR-F840-00250(11K)								
	FR-F840-00310(15K)								
	FR-F840-00380(18.5K)								
	FR-F840-00470(22K)	250	230	400	380	190	10		
	FR-F840-00620(30K)								
	FR-F840-00770(37K)								
	FR-F840-00930(45K)	435	380	550	525	250	12		
	FR-F840-01160(55K)								
	FR-F840-01800(75K)								
	FR-F840-02160(90K)	465	400	620	595	300			
	FR-F840-02600(110K)								
	FR-F840-03250(132K)			740	715	360			
	FR-F840-03610(160K)								
	FR-F840-04320(185K)	498	200	1010	985	380			
FR-F840-04810(220K)									
FR-F840-05470(250K)	680	300	1010	984	380				
FR-F840-06100(280K)									
FR-F840-06830(315K)									

3 WIRING

3.1 Terminal connection diagrams

● FM type

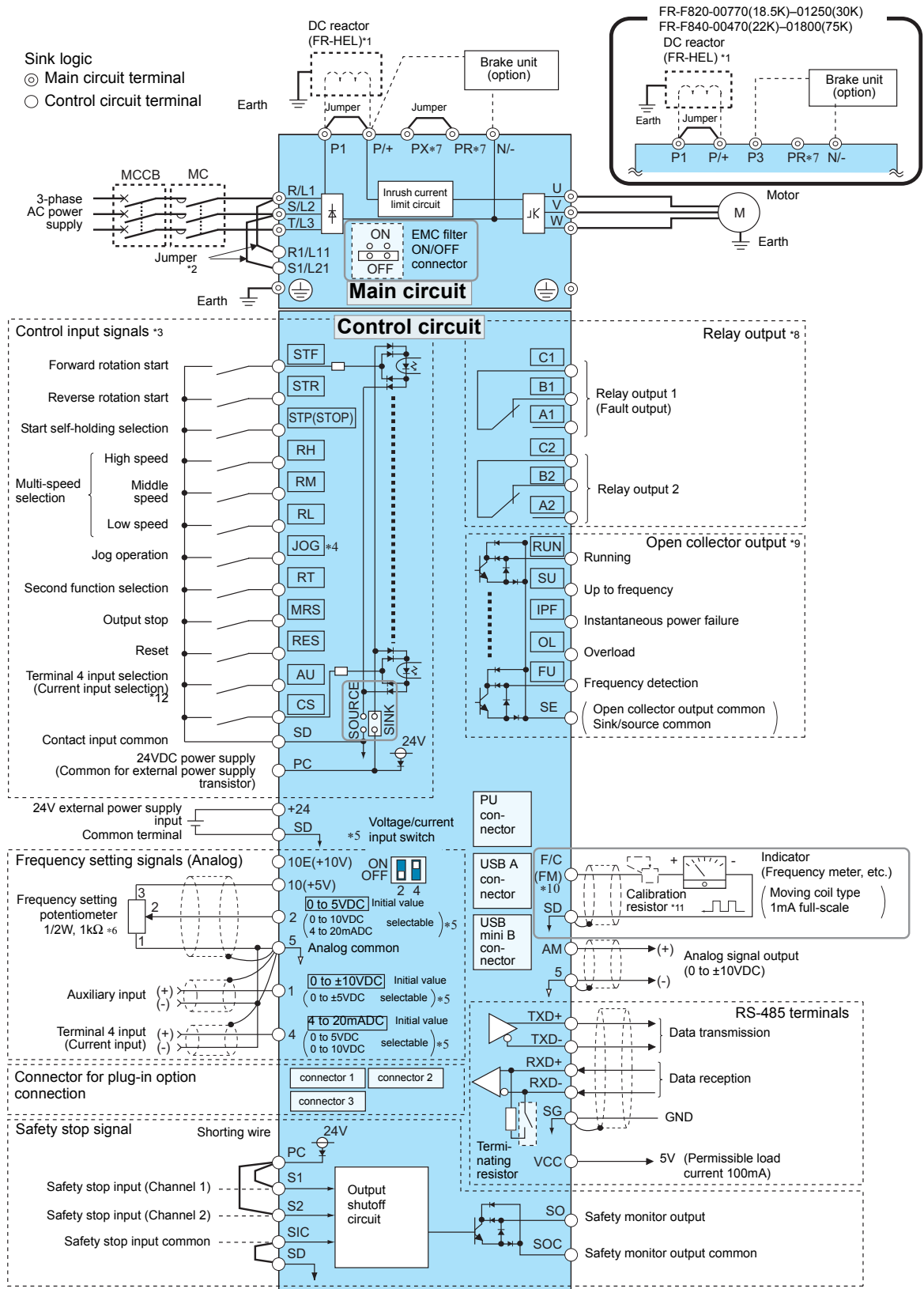

For footnotes *1 to *12 refer to next page.

- *1 For the FR-F820-03160(75K) or higher and FR-F840-01800(75K) or higher always connect a DC reactor (FR-HEL), which is available as an option.
(When selecting a DC reactor, refer to *page 42*, and select one suitable for the applicable motor capacity.) When a DC reactor is connected to the FR-F820-2330(55K) or lower or the FR-F840-01160(55K) or lower, if a jumper is installed across the terminals P1 and P/+, remove the jumper before installing the DC reactor.
- *2 When using separate power supply for the control circuit, remove the jumper between R1/L11 and S1/L21.
- *3 No input voltage is allowed for these terminals. The function of these terminals can be changed with the input terminal assignment (Pr. 178 to Pr. 189). (Refer to *page 25*.)
- *4 Terminal JOG is also used as the pulse train input terminal. Use Pr. 291 to choose JOG or pulse.
- *5 Terminal input specifications can be changed by analog input specification switchover (Pr. 73, Pr. 267). To input a voltage, set the voltage/current input switch OFF. To input a current, set the voltage/current input switch ON. Terminals 10 and 2 are also used as a PTC input terminal. (Pr. 561) (Refer to the Instruction Manual.)
- *6 It is recommended to use 2W, 1k Ω when the frequency setting signal is changed frequently.
- *7 Do not use terminals PR and PX. Do not remove the jumper connected to terminals PR and PX.
- *8 The function of these terminals can be changed with the output terminal assignment (Pr. 195, Pr. 196). (Refer to *page 25*.)
- *9 The function of these terminals can be changed with the output terminal assignment (Pr. 190 to Pr. 194). (Refer to *page 25*.)
- *10 The terminal F/C (FM) can be used to output pulse trains as open collector output by setting Pr. 291.
- *11 Not required when calibrating the scale with the operation panel.
- *12 No function is assigned in the initial status. Assign the function using Pr. 186 „CS terminal function selection“. (Refer to *page 25*.)

CAUTION

- To prevent a malfunction due to noise, keep the signal cables more than 10cm away from the power cables. Also, separate the main circuit cables at the input side from the main circuit cables at the output side.
 - After wiring, wire offcuts must not be left in the inverter.
Wire offcuts can cause an alarm, failure or malfunction. Always keep the inverter clean.
When drilling mounting holes in a control box etc., take care not to allow chips and other foreign matter to enter the inverter.
 - Set the voltage/current input switch in the correct position. An incorrect setting may cause a fault, failure or malfunction.
-



● CA type

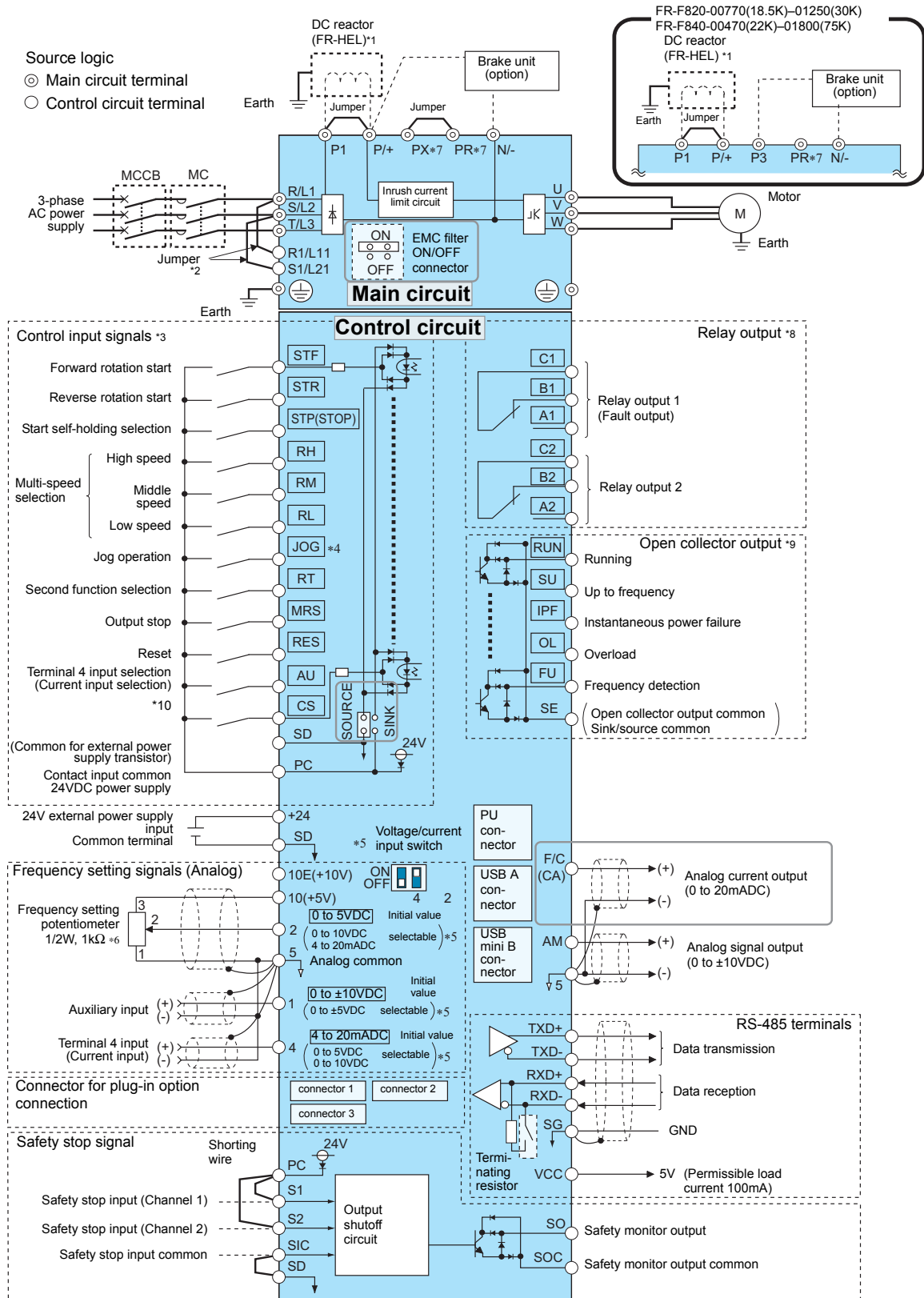

For footnotes *1 to *10 refer to next page.

- *1 For the FR-F820-03160(75K) or higher and FR-F840-01800(75K) or higher always connect a DC reactor (FR-HEL), which is available as an option.
(When selecting a DC reactor, refer to *page 42*, and select one suitable for the applicable motor capacity.) When a DC reactor is connected to the FR-F820-02330(55K) or lower or the FR-F840-01160(55K) or lower, if a jumper is installed across the terminals P1 and P/+, remove the jumper before installing the DC reactor.
- *2 When using separate power supply for the control circuit, remove the jumper between R1/L11 and S1/L21.
- *3 The function of these terminals can be changed with the input terminal assignment (Pr. 178 to Pr. 189). (Refer to *page 25*.)
- *4 Terminal JOG is also used as the pulse train input terminal. Use Pr. 291 to choose JOG or pulse.
- *5 Terminal input specifications can be changed by analog input specification switchover (Pr. 73, Pr. 267). To input a voltage, set the voltage/current input switch OFF. To input a current, set the voltage/current input switch ON. Terminals 10 and 2 are also used as a PTC input terminal. (Pr. 561) (Refer to the Instruction Manual.)
- *6 It is recommended to use 2W, 1k Ω when the frequency setting signal is changed frequently.
- *7 Do not use terminals PR and PX. Do not remove the jumper connected to terminals PR and PX.
- *8 The function of these terminals can be changed with the output terminal assignment (Pr. 195, Pr. 196). (Refer to *page 25*.)
- *9 The function of these terminals can be changed with the output terminal assignment (Pr. 190 to Pr. 194). (Refer to *page 25*.)
- *10 No function is assigned in the initial status. Assign the function using Pr. 186 „CS terminal function selection“. (Refer to *page 25*.)

CAUTION

- To prevent a malfunction due to noise, keep the signal cables more than 10cm away from the power cables. Also, separate the main circuit cables at the input side from the main circuit cables at the output side.
 - After wiring, wire offcuts must not be left in the inverter.
Wire offcuts can cause an alarm, failure or malfunction. Always keep the inverter clean.
When drilling mounting holes in a control box etc., take care not to allow chips and other foreign matter to enter the inverter.
 - Set the voltage/current input switch in the correct position. An incorrect setting may cause a fault, failure or malfunction.
-



3.2 Main circuit terminal

3.2.1 Terminal layout and wiring

<p>FR-F820-00046(0.75K), 00077(1.5K)</p>	<p>FR-F820-00105(2.2K) to 00250(5.5K) FR-F840-00023(0.75K) to 00126(5.5K)</p>	<p>FR-F820-00340(7.5K), 00490(11K) FR-F840-00170(7.5K), 00250(11K)</p>
<p>FR-F820-00630(15K) FR-F840-00310(15K), 00380(18.5K)</p>	<p>FR-F820-00770(18.5K) to 01250(30K) FR-F840-00470(22K), 00620(30K)</p>	<p>FR-F820-01540(37K) *2 FR-F840-00770(37K)</p>
<p>FR-F820-01870(45K), 02330(55K) *1</p>	<p>FR-F820-03160(75K) *1</p>	<p>FR-F840-00930(45K) to 01800(75K) *1, *3</p>
<p>FR-F840-02160(90K), 02600(110K) *1</p>	<p>FR-F820-03800(90K), 04750(110K) *1 FR-F840-03250(132K) to 04810(220K) *1</p>	<p>FR-F840-05470(250K) to 06830(315K) *1</p>

*1 The following diagram shows the positions of R1/L11, S1/L21, and the charge lamp.

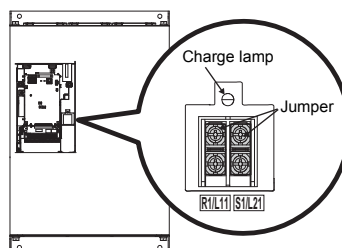

*2 The terminals P3 and PR of the FR-F820-01540(37K) are not equipped with screws. Do not connect anything to these.

*3 For the FR-F840-01800(75K), a jumper is not installed across the terminals P1 and P/+. Always connect a DC reactor (FR-HEL), which is available as an option, across the terminals P1 and P/+.

CAUTION

- The power supply cables must be connected to R/L1, S/L2, T/L3. Never connect the power cable to the U, V, W, of the inverter. Doing so will damage the inverter. (Phase sequence needs not to be matched.)
- Connect the motor to U, V, W. At this time turning on the forward rotation switch (signal) rotates the motor in the clockwise direction when viewed from the motor shaft. (The phase sequence must be matched.)
- The charge lamp will turn ON when the power is supplied to the main circuit.
- When wiring the inverter main circuit conductor of the FR-F840-05470(250K) or higher, tighten a nut from the right side of the conductor. When wiring two wires, place wires on both sides of the conductor (refer to the drawing). For wiring, use bolts (nuts) provided with the inverter.

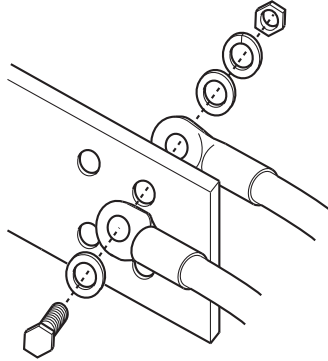



3.3 Wiring fundamentals

3.3.1 Cable size

Select the recommended cable size to ensure that the voltage drop will be 2% max.

If the wiring distance is long between the inverter and motor, the main circuit cable voltage drop will cause the motor torque to decrease especially at the output of a low frequency.

The following table indicates a selection example for the wiring length of 20m.

LD rating (Pr. 570 "Multiple rating setting" = "1")

- 200V class (when input power supply is 220V)

Applicable Inverter Type FR-F820-□	Terminal Screw Size *4	Tightening Torque [Nm]	Crimping Terminal		Cable Sizes								
					HIV, etc. [mm ²] *1				AWG/MCM *2		PVC, etc. [mm ²] *3		
			R/L1, S/L2, T/L3	U, V, W	R/L1, S/L2, T/L3	U, V, W	P/+ , P1	Earth Cable Gauge	R/L1, S/L2, T/L3	U, V, W	R/L1, S/L2, T/L3	U, V, W	Earth Cable Gauge
00046(0.75K) to 00105(2.2K)	M4	1.5	2-4	2-4	2	2	2	2	14	14	2.5	2.5	2.5
00167(3.7K)	M4	1.5	5.5-4	5.5-4	3.5	3.5	3.5	3.5	12	12	4	4	4
00250(5.5K)	M4	1.5	5.5-4	5.5-4	5.5	5.5	5.5	5.5	10	10	6	6	6
00340(7.5K)	M5	2.5	14-5	8-5	14	8	14	5.5	6	8	16	10	16
00490(11K)	M5	2.5	14-5	14-5	14	14	14	8	6	6	16	16	16
00630(15K)	M5	2.5	22-5	22-5	22	22	22	14	4	4	25	25	16
00770(18.5K)	M6	4.4	38-6	38-6	38	38	38	14	2	2	35	35	25
00930(22K)	M8(M6)	7.8	38-8	38-8	38	38	38	22	2	2	35	35	25
01250(30K)	M8(M6)	7.8	60-8	60-8	60	60	60	22	1/0	1/0	50	50	25
01540(37K)	M8(M6)	7.8	80-8	80-8	80	80	80	22	3/0	3/0	70	70	35
01870(45K)	M10(M8)	14.7	100-10	100-10	100	100	100	38	4/0	4/0	95	95	50
02330(55K)	M10(M8)	14.7	100-10	100-10	100	100	100	38	4/0	4/0	95	95	50
03160(75K)	M12(M8)	24.5	150-12	150-12	125	125	150	38	250	250	—	—	—
03800(90K)	M12(M8)	24.5	150-12	150-12	150	150	2×100	38	2×4/0	2×4/0	—	—	—
04750(110K)	M12(M8)	24.5	100-12	100-12	150	150	2×100	38	2×4/0	2×4/0	—	—	—

- 400V class (when input power supply is 440V)

Applicable Inverter Type FR-F840-□	Terminal Screw Size *4	Tightening Torque [Nm]	Crimping Terminal		Cable Sizes								
					HIV, etc. [mm ²] *1				AWG/MCM *2		PVC, etc. [mm ²] *3		
			R/L1, S/L2, T/L3	U, V, W	R/L1, S/L2, T/L3	U, V, W	P/+ , P1	Earth Cable Gauge	R/L1, S/L2, T/L3	U, V, W	R/L1, S/L2, T/L3	U, V, W	Earth Cable Gauge
00023(0.75K) to 00083(3.7K)	M4	1.5	2-4	2-4	2	2	2	2	14	14	2.5	2.5	2.5
00126(5.5K)	M4	1.5	2-4	2-4	2	2	3.5	3.5	12	14	2.5	2.5	4
00170(7.5K)	M4	1.5	5.5-4	5.5-4	3.5	3.5	3.5	3.5	12	12	4	4	4
00250(11K)	M4	1.5	5.5-4	5.5-4	5.5	5.5	5.5	5.5	10	10	6	6	10
00310(15K)	M5	2.5	8-5	8-5	8	8	8	5.5	8	8	10	10	10
00380(18.5K)	M5	2.5	14-5	8-5	14	8	14	8	6	8	16	10	16
00470(22K)	M6	4.4	14-6	14-6	14	14	22	14	6	6	16	16	16
00620(30K)	M6	4.4	22-6	22-6	22	22	22	14	4	4	25	25	16
00770(37K)	M6	4.4	22-6	22-6	22	22	22	14	4	4	25	25	16
00930(45K)	M8	7.8	38-8	38-8	38	38	38	22	1	2	50	50	25
01160(55K)	M8	7.8	60-8	60-8	60	60	60	22	1/0	1/0	50	50	25
01800(75K)	M8	7.8	60-8	60-8	60	60	60	22	1/0	1/0	50	50	25
02160(90K)	M10	14.7	60-10	60-10	60	60	60	22	1/0	1/0	50	50	25
02600(110K)	M10	14.7	80-10	80-10	80	80	80	22	3/0	3/0	70	70	35
03250(132K)	M10(M12)	14.7	100-10	100-10	100	100	100	38	4/0	4/0	95	95	50
03610(160K)	M10(M12)	14.7	150-10	150-10	125	125	100	38	250	250	120	120	70
04320(185K)	M12(M10)	24.5	150-12	150-12	150	150	150	38	300	300	150	150	95
04810(220K)	M12(M10)	24.5	100-12	100-12	2×100	2×100	2×100	60	2×4/0	2×4/0	2×95	2×95	95
05470(250K)	M12(M10)	46	100-12	100-12	2×100	2×100	2×100	60	2×4/0	2×4/0	2×95	2×95	95
06100(280K)	M12(M10)	46	150-12	150-12	2×125	2×125	2×125	60	2×250	2×250	2×120	2×120	120
06830(315K)	M12(M10)	46	150-12	150-12	2×150	2×150	2×125	60	2×300	2×300	2×150	2×150	150

For footnotes *1 to *4 refer to next page.

- *1 For the FR-F820-02330(55K) or lower and FR-F840-01160(55K) or lower, the recommended cable size is that of the HIV cable (600V class 2 vinyl-insulated cable) with continuous maximum permissible temperature of 75°C. Assumes that the surrounding air temperature is 50°C or less and the wiring distance is 20m or less.
For the FR-F820-03160(75K) or higher and FR-F840-01800(75K) or higher, the recommended cable size is that of the LMFC cable (heat resistant flexible cross-linked polyethylene insulated cable) with continuous maximum permissible temperature of 90°C. Assumes that the surrounding air temperature is 50°C or less and wiring is performed in an enclosure.
- *2 For all the 200V class capacities and FR-F840-00930(45K) or lower, the recommended cable size is that of the THHW cable with continuous maximum permissible temperature of 75°C. Assumes that the surrounding air temperature is 40°C or less and the wiring distance is 20m or less.
For the FR-F840-01160(55K) or higher, the recommended cable size is that of THHN cable with continuous maximum permissible temperature of 90°C. Assumes that the surrounding air temperature is 40°C or less and wiring is performed in an enclosure. (Selection example for use mainly in the United States.)
- *3 For the FR-F820-00770(18.5K) or lower and FR-F840-00930(45K) or lower, the recommended cable size is that of the PVC cable with continuous maximum permissible temperature of 70°C. Assumes that the surrounding air temperature is 40°C or less and the wiring distance is 20m or less.
For the FR-F820-00930(22K) or higher and FR-F840-01160(55K) or higher, the recommended cable size is that of XLPE cable with continuous maximum permissible temperature of 90°C. Assumes that the surrounding air temperature is 40°C or less and wiring is performed in an enclosure. (Selection example for use mainly in Europe.)
- *4 The terminal screw size indicates the terminal size for R/L1, S/L2, T/L3, U, V, W, P/+, N/–, P1, P3, and a screw for earthing.
The screw size for earthing of FR-F820-00930(22K) or higher is indicated in brackets.
The screw size for P/+ terminal for connecting an option to FR-F840-03250(132K) or FR-F840-03610(160K) is indicated in brackets.
The screw size for earthing (grounding) of FR-F840-04320(185K) or higher is indicated in brackets.



SLD rating (Pr. 570 "Multiple rating setting" = "0")

- 200V class (when input power supply is 220V)

Applicable Inverter Type FR-F820-□	Terminal Screw Size *4	Tightening Torque [Nm]	Crimping Terminal		Cable Sizes								
					HIV, etc. [mm ²] *1				AWG/MCM *2		PVC, etc. [mm ²] *3		
			R/L1, S/L2, T/L3	U, V, W	R/L1, S/L2, T/L3	U, V, W	P/+, P1	Earth Cable Gauge	R/L1, S/L2, T/L3	U, V, W	R/L1, S/L2, T/L3	U, V, W	Earth Cable Gauge
00046(0.75K) to 00105(2.2K)	M4	1.5	2-4	2-4	2	2	2	2	14	14	2.5	2.5	2.5
00167(3.7K)	M4	1.5	5.5-4	5.5-4	3.5	3.5	3.5	3.5	12	12	4	4	4
00250(5.5K)	M4	1.5	5.5-4	5.5-4	5.5	5.5	5.5	5.5	10	10	6	6	6
00340(7.5K)	M5	2.5	14-5	8-5	14	8	14	5.5	6	8	16	10	16
00490(11K)	M5	2.5	14-5	14-5	14	14	14	8	6	6	16	16	16
00630(15K)	M5	2.5	22-5	22-5	22	22	22	14	4	4	25	25	16
00770(18.5K)	M6	4.4	38-6	38-6	38	38	38	14	2	2	50	50	25
00930(22K)	M8(M6)	7.8	38-8	38-8	38	38	38	22	2	2	50	50	25
01250(30K)	M8(M6)	7.8	60-8	60-8	60	60	60	22	1/0	1/0	50	50	25
01540(37K)	M8(M6)	7.8	80-8	80-8	80	80	80	22	3/0	3/0	70	70	35
01870(45K)	M10(M8)	14.7	100-10	100-10	100	100	100	38	4/0	4/0	95	95	50
02330(55K)	M10(M8)	14.7	100-10	100-10	100	100	100	38	4/0	4/0	95	95	50
03160(75K)	M12(M8)	24.5	150-12	150-12	125	125	150	38	250	250	—	—	—
03800(90K)	M12(M8)	24.5	100-12	100-12	150	150	2×100	38	2×4/0	2×4/0	—	—	—
04750(110K)	M12(M8)	24.5	100-12	100-12	2×100	2×100	2×100	60	2×4/0	2×4/0	—	—	—

- 400V class (when input power supply is 440V)

Applicable Inverter Type FR-F840-□	Terminal Screw Size *4	Tightening Torque [Nm]	Crimping Terminal		Cable Sizes								
					HIV, etc. [mm ²] *1				AWG/MCM *2		PVC, etc. [mm ²] *3		
			R/L1, S/L2, T/L3	U, V, W	R/L1, S/L2, T/L3	U, V, W	P/+, P1	Earth Cable Gauge	R/L1, S/L2, T/L3	U, V, W	R/L1, S/L2, T/L3	U, V, W	Earth Cable Gauge
00023(0.75K) to 00083(3.7K)	M4	1.5	2-4	2-4	2	2	2	2	14	14	2.5	2.5	2.5
00126(5.5K)	M4	1.5	2-4	2-4	2	2	3.5	3.5	12	14	2.5	2.5	4
00170(7.5K)	M4	1.5	5.5-4	5.5-4	3.5	3.5	3.5	3.5	12	12	4	4	4
00250(11K)	M4	1.5	5.5-4	5.5-4	5.5	5.5	5.5	5.5	10	10	6	6	10
00310(15K)	M5	2.5	8-5	8-5	8	8	8	5.5	8	8	10	10	10
00380(18.5K)	M5	2.5	14-5	8-5	14	8	14	8	6	8	16	10	16
00470(22K)	M6	4.4	14-6	14-6	14	14	22	14	6	6	16	16	16
00620(30K)	M6	4.4	22-6	22-6	22	22	22	14	4	4	25	25	16
00770(37K)	M6	4.4	22-6	22-6	22	22	22	14	4	4	25	25	16
00930(45K)	M8	7.8	38-8	38-8	38	38	38	22	1	2	50	50	25
01160(55K)	M8	7.8	60-8	60-8	60	60	60	22	1/0	1/0	50	50	25
01800(75K)	M8	7.8	60-8	60-8	60	60	60	22	1/0	1/0	50	50	25
02160(90K)	M10	14.7	80-10	80-10	80	80	80	22	3/0	3/0	70	70	35
02600(110K)	M10	14.7	100-10	100-10	100	100	100	38	4/0	4/0	95	95	50
03250(132K)	M10(M12)	14.7	150-10	150-10	125	125	100	38	250	250	120	120	120
03610(160K)	M10(M12)	14.7	150-10	150-10	150	150	150	38	300	300	150	150	95
04320(185K)	M12(M10)	24.5	100-12	100-12	2×100	2×100	2×100	60	2×4/0	2×4/0	2×95	2×95	95
04810(220K)	M12(M10)	24.5	100-12	100-12	2×100	2×100	2×100	60	2×4/0	2×4/0	2×95	2×95	95
05470(250K)	M12(M10)	46	150-12	150-12	2×125	2×125	2×125	60	2×250	2×250	2×120	2×120	120
06100(280K)	M12(M10)	46	150-12	150-12	2×150	2×150	2×125	60	2×300	2×300	2×150	2×150	150
06830(315K)	M12(M10)	46	200-12	200-12	2×200	2×200	2×150	100	2×350	2×350	2×185	2×185	2×95

For footnotes *1 to *4 refer to next page.

- *1 For all the 200 V class capacities and FR-F840-01160(55K) or lower, the recommended cable size is that of the HIV cable (600V class 2 vinyl-insulated cable) with continuous maximum permissible temperature of 75°C. Assumes that the surrounding air temperature is 50°C or less and the wiring distance is 20m or less.
For the FR-F840-01800(75K) or higher, the recommended cable size is that of the LMFC cable (heat resistant flexible cross-linked polyethylene insulated cable) with continuous maximum permissible temperature of 90°C. Assumes that the surrounding air temperature is 50°C or less and wiring is performed in an enclosure.
- *2 For all the 200V class capacities and FR-F840-00930(45KK) or lower, the recommended cable size is that of the THHW cable with continuous maximum permissible temperature of 75°C. Assumes that the surrounding air temperature is 40°C or less and the wiring distance is 20m or less.
For the FR-F840-01160(55K) or higher, the recommended cable size is that of THHN cable with continuous maximum permissible temperature of 90°C. Assumes that the surrounding air temperature is 40°C or less and wiring is performed in an enclosure.
(Selection example for use mainly in the United States.)
- *3 For the FR-F820-00930(22K) or lower and FR-F840-00930(45K) or lower, the recommended cable size is that of the PVC cable with continuous maximum permissible temperature of 70°C. Assumes that the surrounding air temperature is 40°C or less and the wiring distance is 20m or less.
For the FR-F820-01250(30K) or higher and FR-F840-01160(55K) or higher, the recommended cable size is that of XLPE cable with continuous maximum permissible temperature of 90°C. Assumes that the surrounding air temperature is 40°C or less and wiring is performed in an enclosure. (Selection example for use mainly in Europe.)
- *4 The terminal screw size indicates the terminal size for R/L1, S/L2, T/L3, U, V, W, P/+, N/–, P1, P3, and a screw for earthing.
The screw size for earthing of FR-F820-00930(22K) or higher is indicated in brackets.
The screw size for P/+ terminal for connecting an option to FR-F840-03250(132K) or FR-F840-03610(160K) is indicated in brackets.
The screw size for earthing (grounding) of FR-F840-04320(185K) or higher is indicated in brackets.

The line voltage drop can be calculated by the following expression:

$$\text{Line voltage drop [V]} = \frac{\sqrt{3} \times \text{wire resistance [m}\Omega\text{/m]} \times \text{wiring distance [m]} \times \text{current [A]}}{1000}$$

Use a larger diameter cable when the wiring distance is long or when it is desired to decrease the voltage drop (torque reduction) in the low speed range.

CAUTION

- Tighten the terminal screw to the specified torque.
A screw that has been tightened too loosely can cause a short circuit or malfunction.
A screw that has been tightened too tightly can cause a short circuit or malfunction due to the unit breakage.
 - Use crimping terminals with insulation sleeve to wire the power supply and motor.
-



3.3.2 Total wiring length

• With general-purpose motor

Connect one or more general-purpose motors within the total wiring length shown in the following table.

Pr. 72 setting (carrier frequency)	FR-F820-00046(0.75K), FR-F840-00023(0.75K)	FR-F820-00077(1.5K), FR-F840-00038(1.5K)	FR-F820-00105(2.2K) or higher FR-F840-00052(2.2K) or higher
2 (2kHz) or lower	300m	500m	500m
3 (3kHz) or higher	200m	300m	500m

When driving a 400V class motor by the inverter, surge voltages attributable to the wiring constants may occur at the motor terminals, deteriorating the insulation of the motor. In this case, take one of the following measure.

- Use a "400V class inverter-driven insulation-enhanced motor" and set frequency in Pr. 72 "PWM frequency selection" according to wiring length.

	Wiring Length		
	≤ 50m	50m–100m	≥ 100m
Pr. 72 setting	≤ 15 (14.5kHz)	≤ 9 (9kHz)	≤ 4 (4kHz)

- Connect the surge voltage suppression filter (FR-ASF-H, FR-BMF-H) to the output side of the FR-F840-01160(55K) or lower and the sine wave filter (MT-BSL, MT-BSC) to the output side of the FR-F840-01800(75K) or higher.

• With PM motor

Use the following wiring length or shorter when connecting a PM motor.

Voltage class	Pr. 72 setting (carrier frequency)	FR-F820-00077(1.5K) or lower, FR-F840-00038(1.5K) or lower	FR-F820-00105(2.2K) or higher FR-F840-00052(2.2K) or higher
200 V	0 (2 kHz) to 15 (14 kHz)	100 m	100 m
400 V	≤ 5 (2 kHz)	100 m	100 m
	6 to 9 (6 kHz)	50 m	100 m
	≥ 10 (10 kHz)	50 m	50 m

Use one PM motor for one inverter. Multiple PM motors cannot be connected to an inverter.

CAUTION

- Especially for long-distance wiring, the inverter may be affected by a charging current caused by stray capacitances of the wiring, leading to an activation of the overcurrent protection, malfunction of the fast-response current limit operation, or even to an inverter failure. If the fast-response current limit function malfunctions, disable this function. (For Pr. 156 "Stall prevention operation selection", refer to the Instruction Manual.)
- The optional surge voltage suppression filter (FR-ASF-H/FR-BMF-H) or sine wave filter (MT-BSL/MT-BSC) cannot be used under PM motor control. Do not connect it.
- For details of Pr. 72 "PWM frequency selection", refer to the Instruction Manual.
- The FR-ASF-H and FR-BMF-H can be used under V/F control and Advanced magnetic flux vector control. The MT-BSL and MT-BSC can be used under V/F control. (For details, refer to the Instruction Manual of the option.)
- Refer to the Instruction Manual to drive a 400V class motor by an inverter.

3.3.3 Cable size of the control circuit power supply (terminal R1/L11, S1/L21)

- Terminal screw size: M4
- Cable size: 0.75mm² to 2mm²
- Tightening torque: 1.5Nm

3.4 Control circuit terminals

3.4.1 Terminal layout

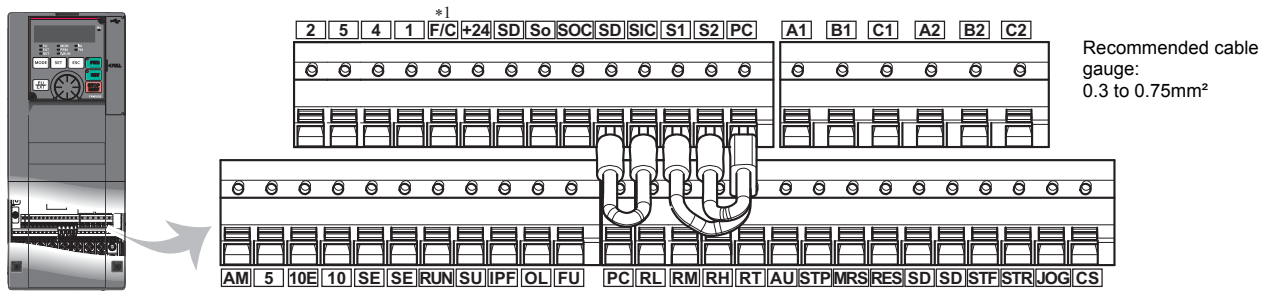

*1 The terminal functions as the terminal FM for the FM type, and as the terminal CA for the CA type.

3.4.2 Wiring method

• Power supply connection

For the control circuit wiring, strip off the sheath of a cable, and use it with a blade terminal. For a single wire, strip off the sheath of the wire and apply directly. Insert the blade terminal or the single wire into a socket of the terminal.

- (1) Strip off the sheath for the below length. If the length of the sheath peeled is too long, a short circuit may occur with neighbouring wires. If the length is too short, wires might come off. Wire the stripped cable after twisting it to prevent it from becoming loose. In addition, do not solder it.

Cable sheath stripping length



- (2) Insert wires into a blade terminal, then crimp the terminal. Insert wires to a blade terminal, and check that the wires come out for about 0 to 0.5 mm from a sleeve. Check the condition of the blade terminal after crimping. Do not use a blade terminal of which the crimping is inappropriate, or the face is damaged.

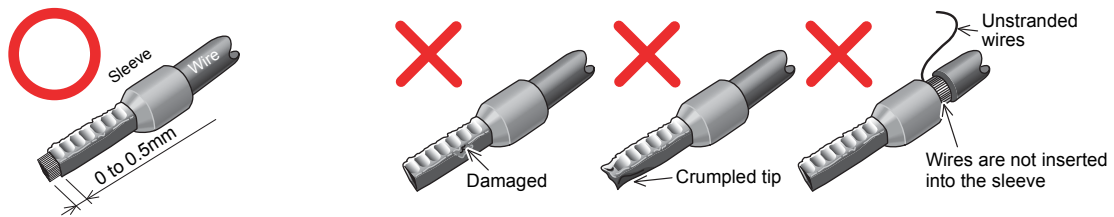

• Blade terminals commercially available (as of February 2012)

Cable gauge (mm ²)	Blade terminal model			Manufacturer	Crimping tool name
	With insulation sleeve	Without insulation sleeve	For UL wire *2		
0.3	AI 0,5-10WH	—	—	Phoenix Contact Co., Ltd.	CRIMPFOX 6
0.5	AI 0,5-10WH	—	AI 0,5-10WH-GB		
0.75	AI 0,75-10GY	A 0,75-10	AI 0,75-10GY-GB		
1	AI 1-10RD	A 1-10	AI 1-10RD/1000GB		
1.25, 1.5	AI 1,5-10BK	A 1,5-10	AI 1,5-10BK/1000GB*3		
0.75 (for two wires)	AI-TWIN 2×0,75-10GY	—	—		

*2 A blade terminal with an insulation sleeve compatible with the MTW wire which has a thick wire insulation.

*3 Applicable for the terminal A1, B1, C1, A2, B2, C2.

Cable gauge (mm ²)	Blade terminal product number	Insulation product number	Manufacturer	Crimping tool product number
0.3 to 0.75	BT 0.75-11	VC 0.75	NICHIFU Co.,Ltd.	NH 69



(3) Insert the wires into a socket.

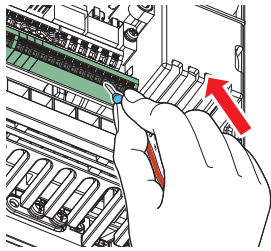

When using a single wire or stranded wires without a blade terminal, push the open/close button all the way down with a flathead screwdriver, and insert the wire.

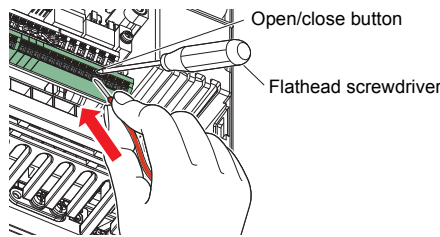

• Wire removal

Pull the wire while pushing the open/close button all the way down firmly with a flathead screwdriver.

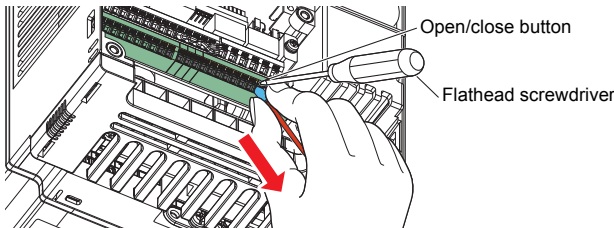

CAUTION

- When using stranded wires without a blade terminal, twist enough to avoid short circuit with a nearby terminals or wires.
- During wiring, pulling out the wire forcefully without pushing the open/close button all the way down may damage the terminal block.
- Use a small flathead screwdriver (tip thickness: 0.4 mm, tip width: 2.5 mm). If a flathead screwdriver with a narrow tip is used, terminal block may be damaged. Commercially available products (as of February 2012).

Name	Model	Manufacturer
Driver	SZF 0- 0,4 x 2,5	Phoenix Contact Co., Ltd.

- Place the flathead screwdriver vertical to the open/close button. In case the blade tip slips, it may cause an inverter damage or injury.

3.4.3 Wiring precautions

- It is recommended to use the cables of 0.3 to 0.75mm² gauge for connection to the control circuit terminals.
- The wiring length should be 30m (200 m for the terminal FM) maximum.
- Use two or more parallel micro-signal contacts or twin contacts to prevent a contact faults when using contact inputs since the control circuit input signals are micro-currents.
- To suppress EMI, use shielded or twisted cables for the control circuit terminals and run them away from the main and power circuits (including the 200 V relay sequence circuit). For the cables connected to the control circuit terminals, connect their shields to the common terminal of the connected control circuit terminal. When connecting an external power supply to the terminal PC, however, connect the shield of the power supply cable to the negative side of the external power supply. Do not directly earth the shield to the enclosure, etc.
- Always apply a voltage to the alarm output terminals (A1, B1, C1, A2, B2, C2) via a relay coil, lamp, etc.

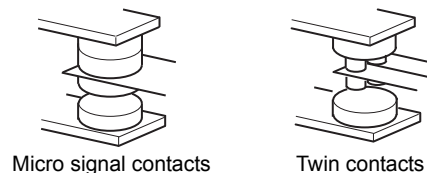

3.4.4 Control logic (sink/source) change

Change the control logic of input signals as necessary.

To change the control logic, change the jumper connector position on the control circuit board. Connect the jumper connector to the connector pin of the desired control logic.

- The control logic of input signals is initially set to the sink logic (SINK) for the FM type.
- The control logic of input signals is initially set to the source logic (SOURCE) for the CA type.

(The output signals may be used in either the sink or source logic independently of the jumper connector position.)

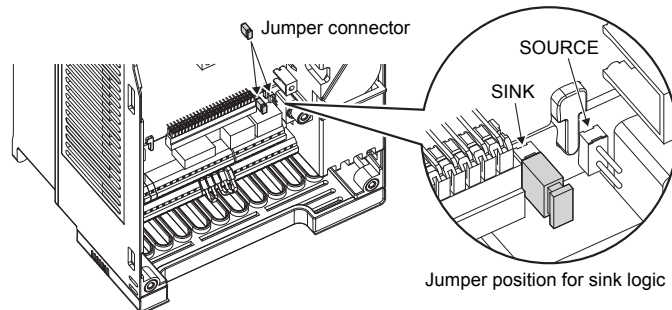

3.4.5 When supplying 24 V external power to the control circuit

Connect the 24 V external power supply across terminals +24 and SD. The 24 V external power supply enables I/O terminal ON/OFF operation, operation panel displays, control functions, and communication during communication operation even during power-OFF of inverter's main circuit power supply.

During the 24 V external power supply operation, "EV" flickers on the operation panel.

- **Applied 24 V external power specification**

Item	Rated specification
Input voltage	23 to 25.5 V DC
Input current	≤ 1.4 A



3.5 Safety stop function

3.5.1 Function description

The terminals related to the safety stop function are shown below.

Terminal symbol	Terminal function description			
S1 *1	For input of the safety stop	Channel 1	Between S1 and SIC	Open: In safety stop mode Short: Other than the safety stop mode
S2 *1		Channel 2	Between S2 and SIC	
SIC *1	Common terminal for terminals S1 and S2			
SO	Outputs when an alarm or failure is detected. The signal is output when no internal safety circuit failure *2 exists.		OFF: Internal safety circuit failure *2 ON: No internal safety circuit failure *2	
SOC	Terminal SO (open collector output) common			

*1 In the initial status, terminals S1 and PC, S2 and PC, and SIC and SD are respectively shorted with shorting wires. To use the safety stop function, remove all the shortening wires, and then connect to the safety relay module as shown in the following connection diagram.

*2 At an internal safety circuit failure, the operation panel displays one of the faults shown on the next page.

CAUTION

Use the terminal SO to output a fault and to prevent restarting of the inverter. The signal cannot be used as safety stop input signal to other devices.

3.5.2 Connection diagram

To prevent automatic restart after a fault occurrence, connect the reset button of a safety relay module or a safety programmable controller across the terminals SO and SOC. The reset button acts as the feedback input for the safety relay module or the safety programmable controller.

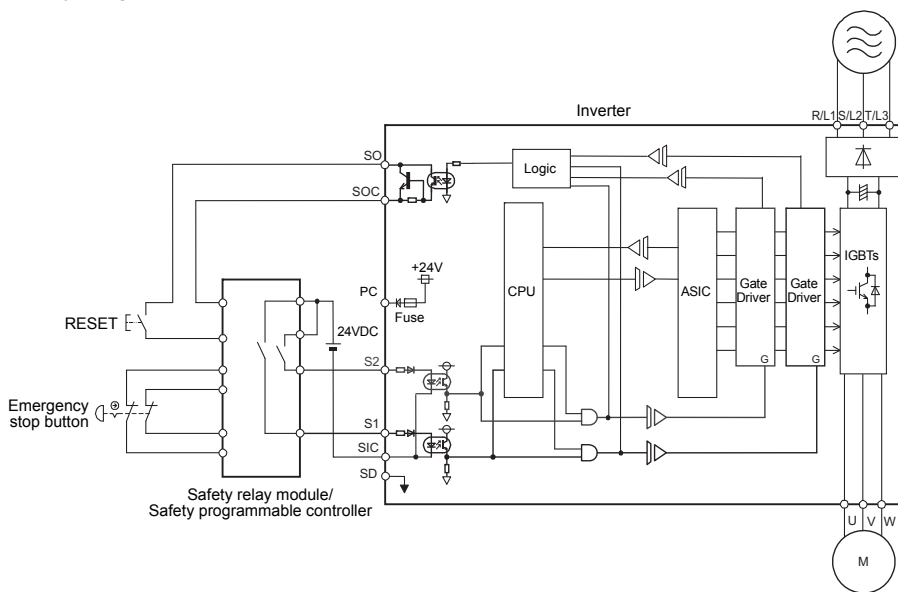

3.5.3 Safety stop function operation

Input power	Internal safety circuit status	Input terminal *1, *2		Output terminal	Inverter operation enable signal	Operation panel indication	
		S1	S2			SO	E.SAF*6
OFF	—	—	—	OFF	Output shutoff (Safe state)	Not displayed	Not displayed
ON	Normal	ON	ON	ON *3	Drive enabled	Not displayed	Not displayed
	Normal	ON	OFF	OFF *4	Output shutoff (Safe state)	Displayed	Displayed
	Normal	OFF	ON	OFF *4	Output shutoff (Safe state)	Displayed	Displayed
	Normal	OFF	OFF	ON *3	Output shutoff (Safe state)	Not displayed	Displayed
	Fault	ON	ON	OFF	Output shutoff (Safe state)	Displayed	Not displayed *5
	Fault	ON	OFF	OFF	Output shutoff (Safe state)	Displayed	Displayed
	Fault	OFF	ON	OFF	Output shutoff (Safe state)	Displayed	Displayed
	Fault	OFF	OFF	OFF	Output shutoff (Safe state)	Displayed	Displayed

*1 ON: Transistor used for an open collector output is conducted.

OFF: Transistor used for an open collector output is not conducted.

*2 When not using the safety stop function, short across terminals S1 and PC, S2 and PC, and SIC and SD to use the inverter. (In the initial status, terminals S1 and PC, S2 and PC, and SIC and SD are respectively shorted with shorting wires.)

*3 If any of the protective functions shown in the following table is activated, the terminal SO turns OFF.

Error Definition	Operation panel indication	Error Definition	Operation panel indication
Option fault	E.OPT	24 VDC power fault	E.P24
Communication option fault	E.OP1	Safety circuit fault	E.SAF
Parameter storage device fault	E.PE	Overspeed occurrence	E.OS
Retry count excess	E.RET	Encoder phase fault	E.EP
Parameter storage device fault	E.PE2	CPU fault	E.CPU
Operation panel power supply short circuit/RS-485 terminal power supply short circuit	E.CTE		E.5 to E.7
		Internal circuit fault	E.13

*4 If the internal safety circuit is operated normally, the terminal SO remains ON until E.SAF is displayed, and the terminal SO turns OFF when E.SAF is displayed.

*5 SA is displayed when the terminals S1 and S2 are identified as OFF due to the internal safety circuit failure.

*6 If another fault occurs at the same time as E.SAF, the other fault can be displayed.

*7 If another warning occurs at the same time as SA, the other warning can be displayed.

For more details, refer to the Safety stop function instruction manual (BCN-A23228-001).
(Find a PDF copy of this manual in the enclosed CD-ROM.)

4 FAILSAFE OF THE SYSTEM WHICH USES THE INVERTER

When a fault is detected by the protective function, the protective function activates and output a fault signal (ALM). However, a fault output signal may not be output at an inverter fault occurrence when the detection circuit or output circuit fails, etc. Although Mitsubishi Electric assures best quality products, provide an interlock which uses inverter status output signals to prevent accidents such as damage to machine when the inverter fails for some reason.

At the same time consider the system configuration where failsafe from outside the inverter, without using the inverter, is enabled even if the inverter fails.

Interlock method which uses the inverter status output signals

By combining the inverter status output signals to provide an interlock as shown below, an inverter alarm can be detected.

Interlock Method	Check Method	Used Signals	Refer to
Inverter protective function operation	Operation check of an alarm contact Circuit error detection by negative logic	Fault output signal (ALM signal)	Refer to chapter "Parameter" of the Instruction Manual
Inverter operating status	Operation ready signal check	Operation ready signal (RY signal)	
Inverter running status	Logic check of the start signal and running signal	Start signal (STF signal, STR signal) Running signal (RUN signal)	
	Logic check of the start signal and output current	Start signal (STF signal, STR signal) Output current detection signal (Y12 signal)	

Backup method outside the inverter

Even if the interlock is provided by the inverter status signal, enough failsafe is not ensured depending on the failure status of the inverter itself. For example, when the inverter CPU fails, even if the interlock is provided using the inverter fault output signal, start signal and RUN signal output, there is a case where a fault output signal is not output and RUN signal is kept output even if an inverter fault occurs.

Provide a speed detector to detect the motor speed and current detector to detect the motor current and consider the backup system such as checking up as below according to the level of importance of the system.

- Start signal and actual operation check**
 Check the motor running and motor current while the start signal is input to the inverter by comparing the start signal to the inverter and detected speed of the speed detector or detected current of the current detector. Note that the current is flowing through the motor while the motor coasts to stop, even after the inverter's start signal is turned OFF. For the logic check, configure a sequence considering the inverter deceleration time. In addition, it is recommended to check the three-phase current when using the current detector.
- Command speed and actual operation check**
 Check if there is no gap between the actual speed and commanded speed by comparing the inverter speed command and detected speed of the speed detector.

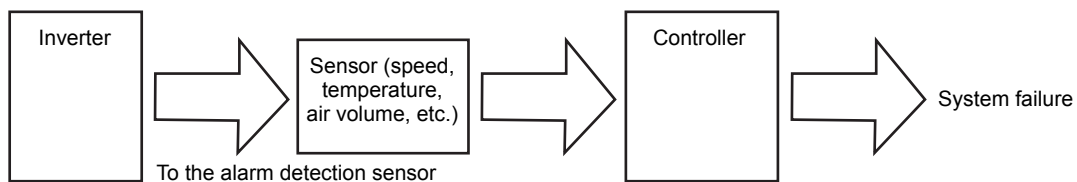

5 PRECAUTIONS FOR USE OF THE INVERTER

The FR-F800 series is a highly reliable product, but incorrect peripheral circuit making or operation/handling method may shorten the product life or damage the product.

Before starting operation, always recheck the following items:

- Use crimping terminals with insulation sleeve to wire the power supply and motor.
- Application of power to the output terminals (U, V, W) of the inverter will damage the inverter. Never perform such wiring.
- After wiring, wire offcuts must not be left in the inverter.
Wire offcuts can cause an alarm, failure or malfunction. Always keep the inverter clean. When drilling mounting holes in a control box etc., take care not to allow chips and other foreign matter to enter the inverter.
- Use cables of the appropriate size to make a voltage drop of 2% maximum.
If the wiring distance is long between the inverter and motor, a voltage drop in the main circuit will cause the motor torque to decrease especially at the output of a low frequency.
Refer to *page 10* for the recommended cable size.
- The overall wiring length should be within the prescribed length.
Especially for long distance wiring, the fast-response current limit function may be reduced or the equipment connected to the inverter output side may malfunction or become faulty under the influence of a charging current due to the stray capacity of the wiring. Therefore, note the overall wiring length. (Refer to *page 14*.)
- Electromagnetic wave interference
The input/output (main circuit) of the inverter includes high frequency components, which may interfere with the communication devices (such as AM radios) used near the inverter. In this case, activate the EMC filter (turn ON the EMC filter ON/OFF connector) to minimize interference. (Refer to the Instruction Manual.)
- Do not install a power factor correction capacitor, varistor or arrester on the inverter output side.
This will cause the inverter to trip or the capacitor, varistor, or arrester to be damaged. If any of the above devices is installed, immediately remove it.
- Before starting wiring or other work after the inverter is operated, wait for at least 10 minutes after the power supply has been switched off, and check that there are no residual voltage using a tester or the like. The capacitor is charged with high voltage for some time after power off and it is dangerous.
- If "EV" is displayed on the operation panel, turn OFF the 24 V external power supply before performing wiring.
- A short circuit or earth fault on the inverter output side may damage the inverter modules.
 - Fully check the insulation resistance of the circuit prior to inverter operation since repeated short circuits caused by peripheral circuit inadequacy or an earth fault caused by wiring inadequacy or reduced motor insulation resistance may damage the inverter modules.
 - Fully check the to-earth insulation and inter-phase insulation of the inverter output side before power-on.
Especially for an old motor or use in hostile atmosphere, securely check the motor insulation resistance etc.
- Do not use the inverter input side magnetic contactor (MC) to start/stop the inverter.
Since repeated inrush currents at power ON will shorten the life of the converter circuit (switching life is about 1,000,000 times), frequent starts and stops of the MC must be avoided.
Always use the start signal (ON/OFF of STF and STR signals) to start/stop the inverter.
- Do not apply a voltage higher than the permissible voltage to the inverter I/O signal circuits.
Contact to the inverter I/O signal circuits or opposite polarity may damage the I/O devices. Especially check the wiring to prevent the speed setting potentiometer from being connected incorrectly to short terminals 10E and 5.
- Provide electrical and mechanical interlocks for MC1 and MC2 which are used for commercial power supply-inverter switch-over.
When the wiring is incorrect or if there is a commercial power supply-inverter switch-over circuit as shown on the right, the inverter will be damaged by leakage current from the power supply due to arcs generated at the time of switch-over or chattering caused by a sequence error.
(The commercial power supply operation is not available with PM motors.)
- If the machine must not be restarted when power is restored after a power failure, provide a magnetic contactor (MC) in the inverter's input side and also make up a sequence which will not switch on the start signal.
If the start signal (start switch) remains on after a power failure, the inverter will automatically restart as soon as the power is restored.

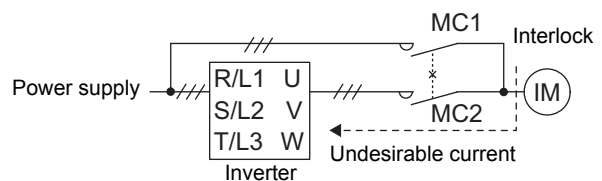



- Inverter input side magnetic contactor (MC)
On the inverter input side, connect an MC for the following purposes. (Refer to the Instruction Manual.)
 - To release the inverter from the power supply when a fault occurs or when the drive is not functioning (e.g. emergency stop operation).
 - To prevent any accident due to an automatic restart at restoration of power after an inverter stop made by a power failure
 - To separate the inverter from the power supply to ensure safe maintenance and inspection work.If using an MC for emergency stop during operation, select an MC regarding the inverter input side current as JEM1038-AC-3 class rated current.
- Handling of inverter output side magnetic contactor
Switch the magnetic contactor between the inverter and motor only when both the inverter and motor are at a stop. When the magnetic contactor is turned ON while the inverter is operating, overcurrent protection of the inverter and such will activate. When MC is provided for switching to the commercial power supply, for example, switch it ON/OFF after the inverter and motor have stopped.
A PM motor is a synchronous motor with high-performance magnets embedded inside. High-voltage is generated at the motor terminals while the motor is running even after the inverter power is turned OFF. Before wiring or inspection, confirm that the motor is stopped. In an application, such as fan and blower, where the motor is driven by the load, a low-voltage manual contactor must be connected at the inverter's output side, and wiring and inspection must be performed while the contactor is open. Otherwise you may get an electric shock.
- Countermeasures against inverter-generated EMI
When the motor speed is unstable, due to change in the frequency setting signal caused by electromagnetic noises from the inverter, take the following measures when applying the motor speed by the analog signal:
 - Do not run the signal cables and power cables (inverter I/O cables) in parallel with each other and do not bundle them.
 - Run signal cables as far away as possible from power cables (inverter I/O cables).
 - Use shielded cables as signal cables.
 - Install a ferrite core on the signal cable (Example: ZCAT3035-1330 TDK).
- Make sure that the specifications and rating match the system requirements.

6 DRIVE THE MOTOR

6.1 Operation panel (FR-DU08)

6.1.1 Components of the operation panel (FR-DU08)

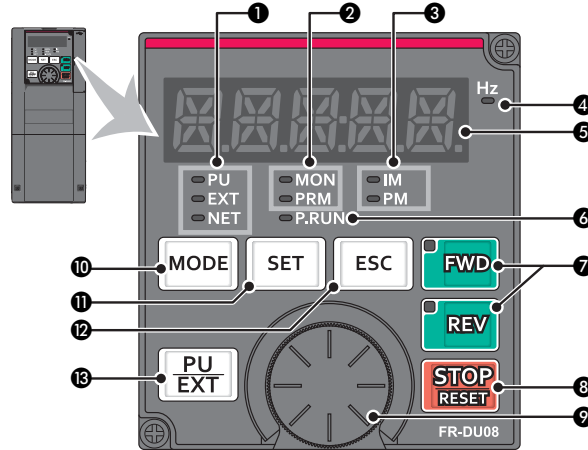

No.	Component	Name	Description
1		Operation mode indicator	PU: Lit to indicate the PU operation mode. EXT: Lit to indicate the External operation mode. (Lit at power-ON in the initial setting.) NET: Lit to indicate the Network operation mode. PU and EXT: Lit to indicate the External/PU combined operation mode 1 or 2.
2		Operation panel status indicator	MON: Lit to indicate the monitoring mode. Quickly flickers twice intermittently while the protective function is activated. Slowly flickers in the display-OFF mode. PRM: Lit to indicate the parameter setting mode.
3		Control motor indicator	IM: Lit to indicate the induction motor control. PM: Lit to indicate the PM motor control. The indicator flickers when test operation is selected.
4		Frequency unit indicator	Lit to indicate frequency. (Flickers when the set frequency is displayed in the monitor.)
5		Monitor (5-digit LED)	Shows the frequency, parameter number, etc. (Using Pr. 52, Pr. 774 to Pr. 776, the monitored item can be changed.)
6		PLC function indicator	Lit to indicate that the sequence program can be executed.
7		FWD key, REV key	FWD key: Starts forward rotation. The LED is lit during forward operation. REV key: Starts reverse rotation. The LED is lit during reverse operation. The LED flickers under the following conditions. <ul style="list-style-type: none"> When the frequency command is not given even if the forward/reverse command is given. When the frequency command is the starting frequency or lower. When the MRS signal is being input.
8		STOP/RESET key	Stops the operation commands. Resets the inverter when the protection function is activated.
9		Setting dial	The setting dial of the Mitsubishi Electric inverters. The setting dial is used to change the frequency and parameter settings. Press the setting dial to perform the following operations: <ul style="list-style-type: none"> To display a set frequency in the monitoring mode (the setting can be changed using Pr. 992.) To display the present setting during calibration To display a fault history number in the faults history mode
10		MODE key	Switches to different modes. Pressing the "MODE" and "PU/EXT" keys simultaneously switches to the easy setting mode. Holding this key for 2 seconds locks the operation. The key lock is invalid when Pr. 161="0 (initial setting)". (Refer to the Instruction Manual.)
11		SET key	Enters each setting. If pressed during operation, the monitored item changes. (Using Pr. 52 and Pr. 774–Pr. 776, the monitored item can be changed.) <div style="text-align: right; margin-top: 10px;"> When the initial setting is set. </div>
12		ESC key	Goes back to the previous display. Holding this key for a longer time changes the mode back to the monitor mode.
13		PU/EXT key	Switches between the PU operation mode, the PU JOG operation mode and the External operation mode. Pressing the "MODE" and "PU/EXT" keys simultaneously switches to the easy setting mode. Cancels the PU stop also.



6.1.2 Basic operation (factory setting)

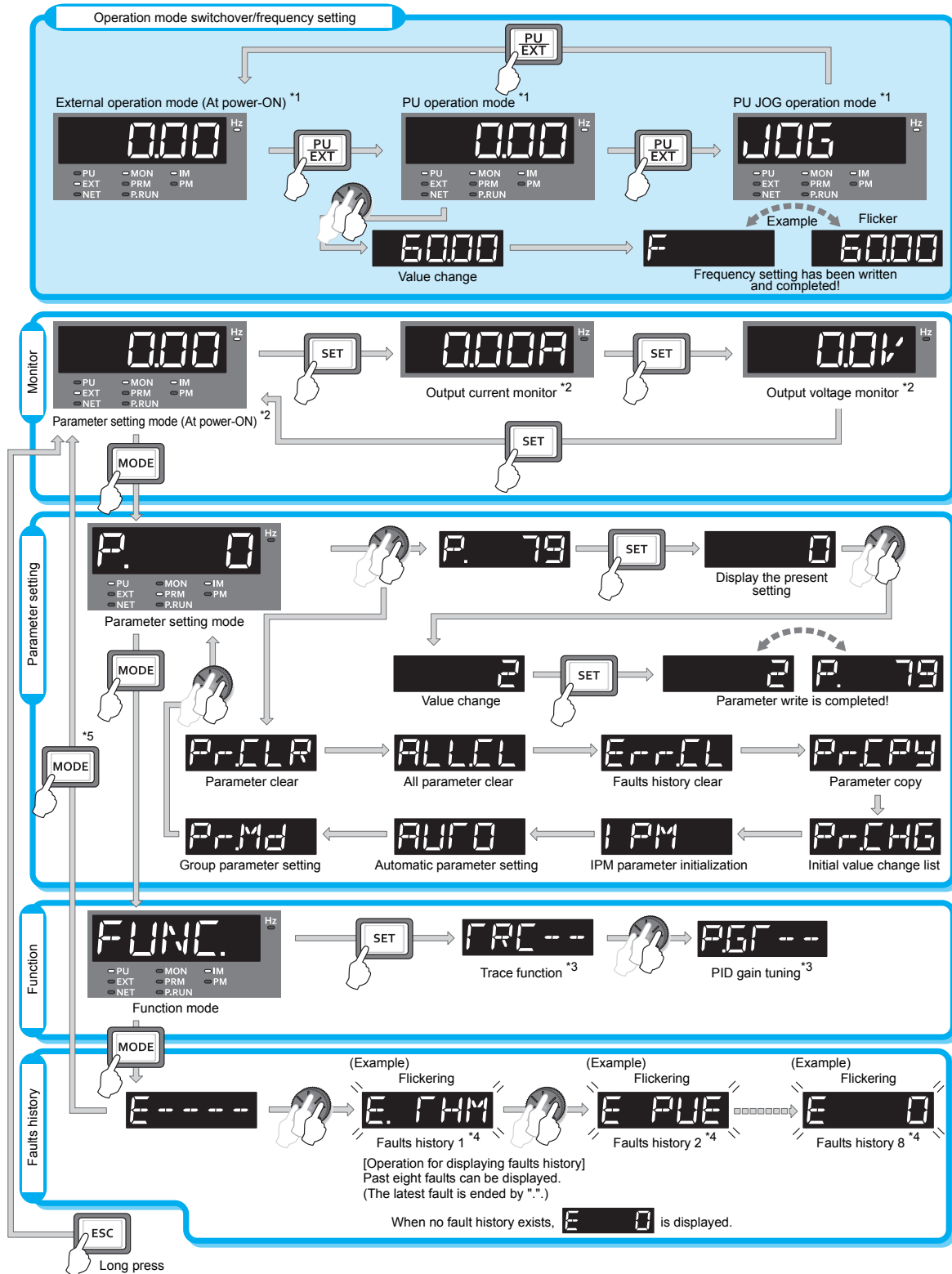

^{*1} For the details of operation modes, refer to the Instruction Manual.

^{*2} Monitored items can be changed. (Refer to the Instruction Manual.)

^{*3} For the details, refer to the Instruction Manual.

^{*4} For the details of faults history, refer to the Instruction Manual.

^{*5} The USB memory mode will appear if a USB memory device is connected. Refer to the Instruction Manual for the USB memory mode.

6.2 Parameter list

For simple variable-speed operation of the inverter, the initial values of the parameters may be used as they are. Set the necessary parameters to meet the load and operational specifications. Parameter setting, change and check can be performed from the operation panel (FR-DU08).

Remark

Simple indicates simple mode parameters. Use Pr. 160 "User group read selection" to switch between the simple mode and extended mode. (Initially set to the extended mode.)

Parameter	Name	Setting Range	Initial Value	Parameter	Name	Setting Range	Initial Value
0	Torque boost Simple	0 to 30%	6/4/3/2/1.5/ 1% *1	18	High speed maximum frequency	120 to 590Hz	120Hz *2 60Hz *3
1	Maximum frequency Simple	0 to 120Hz	120Hz *2 60Hz *3	19	Base frequency voltage	0 to 1000V, 8888, 9999	9999/ 8888 *9
2	Minimum frequency Simple	0 to 120Hz	0Hz	20	Acceleration/ deceleration reference frequency	1 to 590Hz	60/50Hz *9
3	Base frequency Simple	0 to 590Hz	60/50Hz *9	21	Acceleration/ deceleration time increments	0, 1	0
4	Multi-speed setting (high speed) Simple	0 to 590Hz	60/50Hz *9	22	Stall prevention operation level (Torque limit level)	0 to 400%	120/110% *9
5	Multi-speed setting (middle speed) Simple	0 to 590Hz	30Hz	23	Stall prevention operation level compensation factor at double speed	0 to 200%, 9999	9999
6	Multi-speed setting (low speed) Simple	0 to 590Hz	10Hz	24 to 27	Multi-speed setting (4 speed to 7 speed)	0 to 590Hz, 9999	9999
7	Acceleration time Simple	0 to 3600s	5s *4 15s *5	28	Multi-speed input compensation selection	0, 1	0
8	Deceleration time Simple	0 to 3600s	10s *4 30s *5	29	Acceleration/ deceleration pattern selection	0 to 3, 6	0
9	Electronic thermal O/L relay Simple	0 to 500 *2 0 to 3600A *3	Rated inverter current	30	Regenerative function selection	0 to 2, 10, 11, 20, 21, 100 to 102, 110, 111, 120, 121	0
10	DC injection brake operation frequency	0 to 120Hz, 9999	3Hz	31	Frequency jump 1A	0 to 590Hz, 9999	9999
11	DC injection brake operation time	0 to 10s, 8888	0.5s	32	Frequency jump 1B	0 to 590Hz, 9999	9999
12	DC injection brake operation voltage	0 to 30%	4/2/1% *6	33	Frequency jump 2A	0 to 590Hz, 9999	9999
13	Starting frequency	0 to 60Hz	0.5Hz	34	Frequency jump 2B	0 to 590Hz, 9999	9999
14	Load pattern selection	0, 1	1	35	Frequency jump 3A	0 to 590Hz, 9999	9999
15	Jog frequency	0 to 590Hz	5Hz	36	Frequency jump 3B	0 to 590Hz, 9999	9999
16	Jog acceleration/ deceleration time	0 to 3600s	0.5s				
17	MRS input selection	0, 2, 4	0				

*1 Differs according to capacities.

- 6%: FR-F820-00046(0.75K) and FR-F840-00023(0.75K)
- 4%: FR-F820-00077(1.5K) to 00167(3.7K) and FR-F840-00038(1.5K) to 00083(3.7K)
- 3%: FR-F820-00250(5.5K), 00340(7.5K), FR-F840-00126(5.5K) and 00170(7.5K)
- 2%: FR-F820-00490(11K) to 01540(37K) and FR-F840-00250(11K) to 00770(37K)
- 1.5%: FR-F820-01870(45K), 02330(55K), FR-F840-00930(45K) and 01160(55K)
- 1%: FR-F820-03160(75K) or higher and FR-F840-01800(75K) or higher

*2 For FR-F820-02330(55K) or lower and FR-F840-01160(55K) or lower

*3 For FR-F820-03160(75K) or higher and FR-F840-01800(75K) or higher

*4 For FR-F820-00340(7.5K) or lower and FR-F840-00170(7.5K) or lower

*5 For FR-F820-00490(11K) or higher and FR-F840-00250(11K) or higher

*6 Differs according to capacities.

- 4%: FR-F820-00340(7.5K) or lower and FR-F840-00170(7.5K) or lower
- 2%: FR-F820-00490(11K) to 02330(55K) and FR-F840-00250(11K) to 01160(55K)
- 1%: FR-F820-03160(75K) or higher and FR-F840-01800(75K) or higher

*9 Differs according to types. (FM type/CA type)



Parameter	Name	Setting Range	Initial Value
37	Speed display	0, 1 to 9998	0
41	Up-to-frequency sensitivity	0 to 100%	10%
42	Output frequency detection	0 to 590Hz	6Hz
43	Output frequency detection for reverse rotation	0 to 590Hz, 9999	9999
44	Second acceleration/ deceleration time	0 to 3600s	5s
45	Second deceleration time	0 to 3600s, 9999	9999
46	Second torque boost	0 to 30%, 9999	9999
47	Second V/F (base frequency)	0 to 590Hz, 9999	9999
48	Second stall prevention operation level	0 to 400%	120/110% * ⁹
49	Second stall prevention operation frequency	0 to 590Hz, 9999	0Hz
50	Second output frequency detection	0 to 590Hz	30Hz
51	Second electronic thermal O/L relay	0 to 500A, 9999 * ²	9999
		0 to 3600A, 9999 * ³	
52	Operation panel main monitor selection	0, 5 to 14, 17, 18, 20, 23 to 25, 34, 38, 40 to 45, 50 to 57, 61, 62, 64, 67, 68, 81 to 96, 98, 100	0
54	FM/CA terminal function selection * ⁹	1 to 3, 5 to 14, 17, 18, 21, 24, 34, 50, 52, 53, 61, 62, 67, 70, 85, 87 to 90, 92, 93, 95, 98	1
55	Frequency monitoring reference	0 to 590Hz	60/50Hz * ⁹
56	Current monitoring reference	0 to 500A * ²	LD/SLD rated inverter current * ⁹
		0 to 3600A * ³	
57	Restart coasting time	0, 0.1 to 30s, 9999	9999
58	Restart cushion time	0 to 60s	1s
59	Remote function selection	0 to 3, 11 to 13	0
60	Energy saving control selection	0, 4, 9	0
65	Retry selection	0 to 5	0

Parameter	Name	Setting Range	Initial Value
66	Stall prevention operation reduction starting frequency	0 to 590Hz	60/50Hz * ⁹
67	Number of retries at fault occurrence	0 to 10, 101 to 110	0
68	Retry waiting time	0.1 to 600s	1s
69	Retry count display erase	0	0
70	Parameter for manufacturer setting. Do not set.		
71	Applied motor	0 to 6, 13 to 16, 20, 23, 24, 40, 43, 44, 50, 53, 54, 70, 73, 74, 210, 213, 214, 8090, 8093, 8094, 9090, 9093, 9094	0
		0 to 15 * ²	2
72	PWM frequency selection	0 to 6, 25 * ³	
73	Analog input selection	0 to 7, 10 to 17	1
74	Input filter time constant	0 to 8	1
75	Reset selection/ disconnected PU detection/PU stop selection	0 to 3, 14 to 17 * ²	14
		0 to 3, 14 to 17, 100 to 103, 114 to 117 * ³	
76	Fault code output selection	0 to 2	0
77	Parameter write selection	0 to 2	0
78	Reverse rotation prevention selection	0 to 2	0
79	Operation mode selection <i>Simple</i>	0 to 4, 6, 7	0
80	Motor capacity	0.4 to 55kW, 9999 * ²	9999
		0 to 3600kW, 9999 * ³	
81	Number of motor poles	2, 4, 6, 8, 10, 12, 9999	9999
82	Motor excitation current	0 to 500A, 9999 * ²	9999
		0 to 3600A, 9999 * ³	
83	Rated motor voltage	0 to 1000V	200/400V * ⁷
84	Rated motor frequency	10 to 400Hz, 9999	9999

*² For FR-F820-02330(55K) or lower and FR-F840-01160(55K) or lower
 *³ For FR-F820-03160(75K) or higher and FR-F840-01800(75K) or higher
 *⁷ Differs according to the voltage class. (200 V class/400 V class)
 *⁹ Differs according to types. (FM type/CA type)

Parameter	Name	Setting Range	Initial Value
89	Speed control gain (Advanced magnetic flux vector)	0 to 200%, 9999	9999
90	Motor constant (R1)	0 to 50Ω, 9999 * ² 0 to 400mΩ, 9999 * ³	9999
91	Motor constant (R2)	0 to 50Ω, 9999 * ² 0 to 400mΩ, 9999 * ³	9999
92	Motor constant (L1)/ d-axis inductance (Ld)	0 to 6000mH, 9999 * ² 0 to 400mH, 9999 * ³	9999
93	Motor constant (L2)/ q-axis inductance (Lq)	0 to 6000mH, 9999 * ² 0 to 400mH, 9999 * ³	9999
94	Motor constant (X)	0 to 100%, 9999	9999
95	Online auto tuning selection	0, 1	0
96	Auto tuning setting/ status	0, 1, 11, 101	0
100	V/F1 (first frequency)	0 to 590Hz, 9999	9999
101	V/F1 (first frequency voltage)	0 to 1000V	0V
102	V/F2 (second frequency)	0 to 590Hz, 9999	9999
103	V/F2 (second frequency voltage)	0 to 1000V	0V
104	V/F3 (third frequency)	0 to 590Hz, 9999	9999
105	V/F3 (third frequency voltage)	0 to 1000V	0V
106	V/F4 (fourth frequency)	0 to 590Hz, 9999	9999
107	V/F4 (fourth frequency voltage)	0 to 1000V	0V
108	V/F5 (fifth frequency)	0 to 590Hz, 9999	9999
109	V/F5 (fifth frequency voltage)	0 to 1000V	0V
117	PU communication station number	0 to 31	0
118	PU communication speed	48, 96, 192, 384, 576, 768, 1152	192
119	PU communication stop bit length / data length	0, 1, 10, 11	1
120	PU communication parity check	0 to 2	2
121	Number of PU communication retries	0 to 10, 9999	1

Parameter	Name	Setting Range	Initial Value
122	PU communication check time interval	0, 0.1 to 999.8s, 9999	9999
123	PU communication waiting time setting	0 to 150ms, 9999	9999
124	PU communication CR/LF selection	0 to 2	1
125	Terminal 2 frequency setting gain frequency Simple	0 to 590Hz	60/50Hz * ⁹
126	Terminal 4 frequency setting gain frequency Simple	0 to 590Hz	60/50Hz * ⁹
127	PID control automatic switchover frequency	0 to 590Hz, 9999	9999
128	PID action selection	0, 10, 11, 20, 21, 50, 51, 60, 61, 70, 71, 80, 81, 90, 91, 100, 101, 1000, 1001, 1010, 1011, 2000, 2001, 2010, 2011	0
129	PID proportional band	0.1 to 1000%, 9999	100%
130	PID integral time	0.1 to 3600s, 9999	1s
131	PID upper limit	0 to 100%, 9999	9999
132	PID lower limit	0 to 100%, 9999	9999
133	PID action set point	0 to 100%, 9999	9999
134	PID differential time	0.01 to 10.00s, 9999	9999
135	Electronic bypass sequence selection	0, 1	0
136	MC switchover interlock time	0 to 100s	1s
137	Start waiting time	0 to 100s	0.5s
138	Bypass selection at a fault	0, 1	0
139	Automatic switch- over frequency between inverter and commercial power- supply operation	0 to 60Hz, 9999	9999
140	Backlash acceleration stopping frequency	0 to 590Hz	1Hz
141	Backlash acceleration stopping time	0 to 360s	0.5s

*² For FR-F820-02330(55K) or lower and FR-F840-01160(55K) or lower

*³ For FR-F820-03160(75K) or higher and FR-F840-01800(75K) or higher

*⁹ Differs according to types. (FM type/CA type)



Parameter	Name	Setting Range	Initial Value	Parameter	Name	Setting Range	Initial Value	
142	Backlash deceleration stopping frequency	0 to 590Hz	1Hz	165	Stall prevention operation level for restart	0 to 400%	120/110% ^{*9}	
143	Backlash deceleration stopping time	0 to 360s	0.5s	166	Output current detection signal retention time	0 to 10s, 9999	0.1s	
144	Speed setting switchover	0, 2, 4, 6, 8, 10, 102, 104, 106, 108, 110, 112	4	167	Output current detection operation selection	0, 1, 10, 11	0	
145	PU display language selection	0 to 7	1	168	Parameter for manufacturer setting. Do not set.			
147	Acceleration/ deceleration time switching frequency	0 to 590Hz, 9999	9999	169				
148	Stall prevention level at 0V input	0 to 400%	120/110% ^{*9}	170	Watt-hour meter clear	0, 10, 9999	9999	
149	Stall prevention level at 10V input	0 to 400%	150/120% ^{*9}	171	Operation hour meter clear	0, 9999	9999	
150	Output current detection level	0 to 400%	120/110% ^{*9}	172	User group registered display/ batch clear	9999, (0 to 16)	0	
151	Output current detection signal delay time	0 to 10s	0s	173	User group registration	0 to 1999, 9999	9999	
152	Zero current detection level	0 to 400%	5%	174	User group clear	0 to 1999, 9999	9999	
153	Zero current detection time	0 to 10s	0.5s	178	STF terminal function selection	0 to 8, 10 to 14, 16, 18, 24, 25, 28, 37, 46 to 48, 50, 51, 60 to 62, 64 to 67, 70 to 73, 77 to 81, 84, 94 to 98, 9999 ^{*11}	60	
154	Voltage reduction selection during stall prevention operation	0, 1, 10, 11	1	179	STR terminal function selection		61	
155	RT signal function validity condition selection	0, 10	0	180	RL terminal function selection		0	
156	Stall prevention operation selection	0 to 31, 100, 101	0	181	RM terminal function selection		1	
157	OL signal output timer	0 to 25s, 9999	0s	182	RH terminal function selection		2	
158	AM terminal function selection	1 to 3, 5 to 14, 17, 18, 21, 24, 34, 50, 52 to 54, 61, 62, 67, 70, 86 to 96, 98	1	183	RT terminal function selection		3	
159	Automatic switch-over frequency range from bypass to inverter operation	0 to 10Hz, 9999	9999	184	AU terminal function selection		4	
160	User group read selection <i>Simple</i>	0, 1, 9999	9999/0 ^{*9}	185	JOG terminal function selection		5	
161	Frequency setting/ key lock operation selection	0, 1, 10, 11	0	186	CS terminal function selection		9999	
162	Automatic restart after instantaneous power failure selection	0 to 3, 10 to 13	0	187	MRS terminal function selection		24	
163	First cushion time for restart	0 to 20s	0s	188	STOP terminal function selection		25	
164	First cushion voltage for restart	0 to 100%	0%	189	RES terminal function selection		62	
				190	RUN terminal function selection		0 to 5, 7, 8, 10 to 19, 25, 26, 35, 39, 40, 45 to 54, 57, 64 to 68, 70 to 79, 82, 85, 90 to 96, 98 to 105, 107, 108, 110 to 116, 125, 126, 135, 139, 140, 145 to 154, 157, 164 to 168, 170 to 179, 182, 185, 190 to 196, 198 to 208, 211 to 213, 215, 300 to 308, 311 to 313, 315, 9999 ^{*12}	0
				191	SU terminal function selection		1	
				192	IPF terminal function selection		2	
				193	OL terminal function selection		3	
				194	FU terminal function selection	4		
				195	ABC1 terminal function selection	99		
				196	ABC2 terminal function selection	9999		

^{*9} Differs according to types. (FM type/CA type)

^{*11} The setting value "60" is only available for Pr. 178, and "61" is only for Pr. 179.

^{*12} The setting values "92, 93, 192, 193" are only available for Pr. 190 to Pr. 194.

Parameter	Name	Setting Range	Initial Value
232 to 239	Multi-speed setting (speeds 8 to 15)	0 to 590Hz, 9999	9999
240	Soft-PWM operation selection	0, 1	1
241	Analog input display unit switchover	0, 1	0
242	Terminal 1 added compensation amount (terminal 2)	0 to 100%	100%
243	Terminal 1 added compensation amount (terminal 4)	0 to 100%	75%
244	Cooling fan operation selection	0, 1, 101 to 105	1
245	Rated slip	0 to 50%, 9999	9999
246	Slip compensation time constant	0.01 to 10s	0.5s
247	Constant-power range slip compensation selection	0, 9999	9999
248	Self power management selection	0 to 2	0
249	Earth fault detection at start	0, 1	0
250	Stop selection	0 to 100s, 1000 to 1100s, 8888, 9999	9999
251	Output phase loss protection selection	0, 1	1
252	Override bias	0 to 200%	50%
253	Override gain	0 to 200%	150%
254	Main circuit power OFF waiting time	0 to 3600s, 9999	600s
255	Life alarm display	(0 to 15)	0
256	Inrush current limit circuit life display	(0 to 100%)	100%
257	Control circuit capacitor life display	(0 to 100%)	100%
258	Main circuit capacitor life display	(0 to 100%)	100%
259	Main circuit capacitor life measuring	0, 1	0
260	PWM frequency automatic switchover	0, 1	1
261	Power failure stop selection	0 to 2, 21, 22	0
262	Subtracted frequency at deceleration start	0 to 20Hz	3Hz
263	Subtraction starting frequency	0 to 590Hz, 9999	60/50Hz * ⁹
264	Power-failure deceleration time 1	0 to 3600s	5s
265	Power-failure deceleration time 2	0 to 3600s, 9999	9999

Parameter	Name	Setting Range	Initial Value
266	Power failure deceleration time switchover frequency	0 to 590Hz	60/50Hz * ⁹
267	Terminal 4 input selection	0 to 2	0
268	Monitor decimal digits selection	0, 1, 9999	9999
269	Parameter for manufacturer setting. Do not set.		
289	Inverter output terminal filter	5 to 50ms, 9999	9999
290	Monitor negative output selection	0 to 7	0
291	Pulse train I/O selection	0, 1, 10, 11, 20, 21, 100 (FM type) 0,1 (CA type)	0
294	UV avoidance voltage gain	0 to 200%	100%
295	Frequency change increment amount setting	0, 0.01, 0.10, 1.00, 10.00	0
296	Password lock level	0 to 6, 99, 100 to 106, 199, 9999	9999
297	Password lock/unlock	(0 to 5), 1000 to 9998, 9999	9999
298	Frequency search gain	0 to 32767, 9999	9999
299	Rotation direction detection selection at restarting	0, 1, 9999	9999
331	RS-485 communication station	0 to 31 (0 to 247)	0
332	RS-485 communication speed	3, 6, 12, 24, 48, 96, 192, 384, 576, 768, 1152	96
333	RS-485 communication stop bit length/data length	0, 1, 10, 11	1
334	RS-485 communication parity check selection	0 to 2	2
335	RS-485 communication retry count	0 to 10, 9999	1
336	RS-485 communication check time interval	0 to 999.8s, 9999	0s
337	RS-485 communication waiting time setting	0 to 150ms, 9999	9999
338	Communication operation command source	0, 1	0
339	Communication speed command source	0 to 2	0
340	Communication startup mode selection	0 to 2, 10, 12	0

*⁹ Differs according to types. (FM type/CA type)



Parameter	Name	Setting Range	Initial Value
341	RS-485 communication CR/LF selection	0 to 2	1
342	Communication EEPROM write selection	0, 1	0
343	Communication error count	—	0
374	Overspeed detection level	0 to 590Hz, 9999	9999
384	Input pulse division scaling factor	0 to 250	0
385	Frequency for zero input pulse	0 to 590Hz	0
386	Frequency for maximum input pulse	0 to 590Hz	60/50Hz * ⁹
390	% setting reference frequency	1 to 590Hz	60/50Hz * ⁹
414	PLC function operation selection	0 to 2	0
415	Inverter operation lock mode setting	0, 1	0
416	Pre-scale function selection	0 to 5	0
417	Pre-scale setting value	0 to 32767	1
450	Second applied motor	0, 1, 3 to 6, 13 to 16, 20, 23, 24, 40, 43, 44, 50, 53, 54, 70, 73, 74, 210, 213, 214, 8090, 8093, 8094, 9090, 9093, 9094, 9999	9999
453	Second motor capacity	0.4 to 55kW, 9999 * ² 0 to 3600kW, 9999 * ³	9999
454	Number of second motor poles	2, 4, 6, 8, 10, 12, 9999	9999
455	Second motor excitation current	0 to 500A, 9999 * ² 0 to 3600A, 9999 * ³	9999

Parameter	Name	Setting Range	Initial Value
456	Rated second motor voltage	0 to 1000V	200/400V * ⁷
457	Rated second motor frequency	10 to 400Hz, 9999	9999
458	Second motor constant (R1)	0 to 50Ω, 9999 * ² 0 to 400mΩ, 9999 * ³	9999
459	Second motor constant (R2)	0 to 50Ω, 9999 * ² 0 to 400mΩ, 9999 * ³	9999
460	Second motor constant(L1)/ d-axis inductance (Ld)	0 to 6000mH, 9999 * ² 0 to 400mH, 9999 * ³	9999
461	Second motor constant (L2)/q-axis inductance (Lq)	0 to 6000mH, 9999 * ² 0 to 400mH, 9999 * ³	9999
462	Second motor constant (X)	0 to 100%, 9999	9999
463	Second motor auto tuning setting/status	0, 1, 11, 101	0
495	Remote output selection	0, 1, 10, 11	0
496	Remote output data 1	0 to 4095	0
497	Remote output data 2	0 to 4095	0
498	PLC function flash memory clear	0, 9696 (0 to 9999)	0
502	Stop mode selection at communication error	0 to 3	0
503	Maintenance timer 1	0 (1 to 9998)	0
504	Maintenance timer 1 alarm output set time	0 to 9998, 9999	9999
505	Speed setting reference	1 to 590Hz	60/50Hz * ⁹
514	Emergency drive dedicated waiting time	0.1 to 600s, 9999	9999
515	Emergency drive dedicated retry count	1 to 200, 9999	1
522	Output stop frequency	0 to 590Hz, 9999	9999
523	Emergency drive mode selection	100, 111, 112, 121, 122, 123, 124, 200, 211, 212, 221, 222, 223, 224, 300, 311, 312, 321, 322, 323, 324, 400, 411, 412, 421, 422, 423, 424, 9999	9999
524	Emergency drive running speed	0 to 590Hz/ 0 to 100%, 9999	9999

*² For FR-F820-02330(55K) or lower and FR-F840-01160(55K) or lower

*³ For FR-F820-03160(75K) or higher and FR-F840-01800(75K) or higher

*⁷ Differs according to the voltage class. (200V class/400V class)

*⁹ Differs according to types. (FM type/CA type)

Parameter	Name	Setting Range	Initial Value	Parameter	Name	Setting Range	Initial Value
539	Modbus-RTU communication check time interval	0 to 999.8s, 9999	9999	578	Auxiliary motor operation selection	0 to 3	0
547	USB communication station number	0 to 31	0	579	Motor connection function selection	0 to 3	0
548	USB communication check time interval	0 to 999.8s, 9999	9999	580	MC switching interlock time	0 to 100s	1s
549	Protocol selection	0, 1, 2	0	581	Start waiting time	0 to 100s	1s
550	NET mode operation command source selection	0, 1, 9999	9999	582	Auxiliary motor connection-time deceleration time	0 to 3600s, 9999	1s
551	PU mode operation command source selection	1 to 3, 9999	9999	583	Auxiliary motor disconnection-time acceleration time	0 to 3600s, 9999	1s
552	Frequency jump range	0 to 30Hz, 9999	9999	584	Auxiliary motor 1 starting frequency	0 to 590Hz	60/50Hz ^{*9}
553	PID deviation limit	0 to 100%, 9999	9999	585	Auxiliary motor 2 starting frequency	0 to 590Hz	60/50Hz ^{*9}
554	PID signal operation selection	0 to 3, 10 to 13	0	586	Auxiliary motor 3 starting frequency	0 to 590Hz	60/50Hz ^{*9}
555	Current average time	0.1 to 1.0s	1s	587	Auxiliary motor 1 stopping frequency	0 to 590Hz	0Hz
556	Data output mask time	0 to 20s	0s	588	Auxiliary motor 2 stopping frequency	0 to 590Hz	0Hz
557	Current average value monitor signal output reference current	0 to 500A ^{*2} 0 to 3600A ^{*3}	LD/SLD rated inverter current ^{*9}	589	Auxiliary motor 3 stopping frequency	0 to 590Hz	0Hz
560	Second frequency search gain	0 to 32767, 9999	9999	590	Auxiliary motor start detection time	0 to 3600s	5s
561	PTC thermistor protection level	0.5 to 30k Ω , 9999	9999	591	Auxiliary motor stop detection time	0 to 3600s	5s
563	Energization time carrying-over times	(0 to 65535)	0	592	Traverse function selection	0 to 2	0
564	Operating time carrying-over times	(0 to 65535)	0	593	Maximum amplitude amount	0 to 25%	10%
569	Second motor speed control gain	0 to 200%, 9999	9999	594	Amplitude compensation amount during deceleration	0 to 50%	10%
570	Multiple rating setting	0, 1	1/0 ^{*9}	595	Amplitude compensation amount during acceleration	0 to 50%	10%
571	Holding time at a start	0 to 10s, 9999	9999	596	Amplitude acceleration time	0.1 to 3600s	5s
573	4mA input check selection	1 to 4, 9999	9999	597	Amplitude deceleration time	0.1 to 3600s	5s
574	Second motor online auto tuning	0, 1	0	598 ^{*13}	Undervoltage level	350 to 430V, 9999	9999
575	Output interruption detection time	0 to 3600s, 9999	1s	599	X10 terminal input selection	0, 1	0
576	Output interruption detection level	0 to 590Hz	0Hz	600	First free thermal reduction frequency 1	0 to 590Hz, 9999	9999
577	Output interruption release level	900 to 1100%	1000%				

^{*2} For FR-F820-02330(55K) or lower and FR-F840-01160(55K) or lower

^{*3} For FR-F820-03160(75K) or higher and FR-F840-01800(75K) or higher

^{*9} Differs according to types. (FM type/CA type)

^{*13} The setting is available only with the 400V class.



Parameter	Name	Setting Range	Initial Value
601	First free thermal reduction ratio 1	1 to 100%	100%
602	First free thermal reduction frequency 2	0 to 590Hz, 9999	9999
603	First free thermal reduction ratio 2	1 to 100%	100%
604	First free thermal reduction frequency 3	0 to 590Hz, 9999	9999
606	Power failure stop external signal input selection	0, 1	1
607	Motor permissible load level	110 to 250%	150%
608	Second motor permissible load level	110 to 250%, 9999	9999
609	PID set point/ deviation input selection	1 to 5	2
610	PID measured value input selection	1 to 5, 101 to 105	3
611	Acceleration time at a restart	0 to 3600s, 9999	9999
653	Speed smoothing control	0 to 200%	0%
654	Speed smoothing cutoff frequency	0 to 120Hz	20Hz
655	Analog remote output selection	0, 1, 10, 11	0
656	Analog remote output 1	800 to 1200%	1000%
657	Analog remote output 2	800 to 1200%	1000%
658	Analog remote output 3	800 to 1200%	1000%
659	Analog remote output 4	800 to 1200%	1000%
660	Increased magnetic excitation deceleration operation selection	0, 1	0
661	Magnetic excitation increase rate	0 to 40%, 9999	9999
662	Increased magnetic excitation current level	0 to 300%	100%
665	Regeneration avoidance frequency gain	0 to 200%	100%
668	Power failure stop frequency gain	0 to 200%	100%
673	SF-PR slip amount adjustment operation selection	2, 4, 6, 9999	9999
674	SF-PR slip amount adjustment gain	0 to 500%	100%

Parameter	Name	Setting Range	Initial Value
684	Tuning data unit switchover	0, 1	0
686	Maintenance timer 2	0 (1 to 9998)	0
687	Maintenance timer 2 warning output set time	0 to 9998, 9999	9999
688	Maintenance timer 3	0 (1 to 9998)	0
689	Maintenance timer 3 warning output set time	0 to 9998, 9999	9999
692	Second free thermal reduction frequency 1	0 to 590Hz, 9999	9999
693	Second free thermal reduction ratio 1	1 to 100%	100%
694	Second free thermal reduction frequency 2	0 to 590Hz, 9999	9999
695	Second free thermal reduction ratio 2	1 to 100%	100%
696	Second free thermal reduction frequency 3	0 to 590Hz, 9999	9999
699	Input terminal filter	5 to 50ms, 9999	9999
702	Maximum motor frequency	0 to 400Hz, 9999	9999
706	Induced voltage constant (ϕf)	0 to 5000mV/(rad/s), 9999	9999
707	Motor inertia (integer)	10 to 999, 9999	9999
711	Motor Ld decay ratio	0 to 100%, 9999	9999
712	Motor Lq decay ratio	0 to 100%, 9999	9999
717	Starting resistance tuning compensation	0 to 200%, 9999	9999
721	Starting magnetic pole position detection pulse width	0 to 6000 μ s, 10000 to 16000 μ s, 9999	9999
724	Motor inertia (exponent)	0 to 7, 9999	9999
725	Motor protection current level	100 to 500%, 9999	9999
726	Auto Baudrate/Max Master	0 to 255	255
727	Max Info Frames	1 to 255	1
728	Device instance number (Upper 3 digits)	0 to 419	0
729	Device instance number (Lower 4 digits)	0 to 9999	0

Parameter	Name	Setting Range	Initial Value
738	Second motor induced voltage constant (phi f)	0 to 5000mV/(rad/s), 9999	9999
739	Second motor Ld decay ratio	0 to 100%, 9999	9999
740	Second motor Lq decay ratio	0 to 100%, 9999	9999
741	Second starting resistance tuning compensation	0 to 200%, 9999	9999
742	Second motor magnetic pole detection pulse width	0 to 6000μs, 10000 to 16000μs,9999	9999
743	Second motor maximum frequency	0 to 400Hz, 9999	9999
744	Second motor inertia (integer)	10 to 999, 9999	9999
745	Second motor inertia (exponent)	0 to 7, 9999	9999
746	Second motor protection current level	100 to 500%, 9999	9999
753	Second PID action selection	0, 10, 11, 20, 21, 50, 51, 60, 61, 70, 71, 80, 81, 90, 91, 100, 101, 1000, 1001, 1010, 1011, 2000, 2001, 2010, 2011	0
754	Second PID control automatic switch-over frequency	0 to 590Hz, 9999	9999
755	Second PID action set point	0 to 100%, 9999	9999
756	Second PID proportional band	0.1 to 1000%, 9999	100 %
757	Second PID integral time	0.1 to 3600s, 9999	1 s
758	Second PID differential time	0.01 to 10.00s, 9999	9999
759	PID unit selection	0 to 43, 9999	9999
760	Pre-charge fault selection	0, 1	0
761	Pre-charge ending level	0 to 100%, 9999	9999
762	Pre-charge ending time	0 to 3600s, 9999	9999
763	Pre-charge upper detection level	0 to 100%, 9999	9999
764	Pre-charge time limit	0 to 3600s, 9999	9999

Parameter	Name	Setting Range	Initial Value
765	Second pre-charge fault selection	0, 1	0 %
766	Second pre-charge ending level	0 to 100%, 9999	9999
767	Second pre-charge ending time	0 to 3600s, 9999	9999
768	Second pre-charge upper detection level	0 to 100%, 9999	9999
769	Second pre-charge time limit	0 to 3600s, 9999	9999
774	Operation panel monitor selection 1	1 to 3, 5 to 14, 17, 18, 20, 23 to 25, 34, 38, 40 to 45, 50 to 57, 61, 62, 64, 67, 68, 81 to 96, 98,100, 9999	9999
775	Operation panel monitor selection 2		9999
776	Operation panel monitor selection 3		9999
777	4mA input fault operation frequency	0 to 590Hz, 9999	9999
778	4mA input check filter	0 to 10s	0
779	Operation frequency during communication error	0 to 590Hz, 9999	9999
791	Acceleration time in low-speed range	0 to 3600s, 9999	9999
792	Deceleration time in low-speed range	0 to 3600s, 9999	9999
799	Pulse increment setting for output power	0.1, 1, 10, 100, 1000kWh	1kWh
800	Control method selection	9, 20	20
820	Speed control P gain 1	0 to 1000%	25%
821	Speed control integral time 1	0 to 20s	0.333s
822	Speed setting filter 1	0 to 5s, 9999	9999
824	Torque control P gain 1 (current loop proportional gain)	0 to 500%	50%
825	Torque control integral time 1 (current loop integral time)	0 to 500ms	40ms
827	Torque detection filter 1	0 to 0.1s	0s
828	Parameter for manufacturer setting. Do not set.		
830	Speed control P gain 2	0 to 1000%, 9999	9999



Parameter	Name	Setting Range	Initial Value
831	Speed control integral time 2	0 to 20s, 9999	9999
832	Speed setting filter 2	0 to 5s, 9999	9999
834	Torque control P gain 2	0 to 500%, 9999	9999
835	Torque control integral time 2	0 to 500ms, 9999	9999
837	Torque detection filter 2	0 to 0.1s, 9999	9999
849	Analog input offset adjustment	0 to 200%	100%
858	Terminal 4 function assignment	0, 4, 9999	0
859	Torque current/Rated PM motor current	0 to 500A, 9999 ^{*2}	9999
		0 to 3600A, 9999 ^{*3}	
860	Second motor torque current/Rated PM motor current	0 to 500A, 9999 ^{*2}	9999
		0 to 3600A, 9999 ^{*3}	
864	Torque detection	0 to 400%	150%
866	Torque monitoring reference	0 to 400%	150%
867	AM output filter	0 to 5s	0.01s
868	Terminal 1 function assignment	0, 4, 9999	0
869 ^{*10}	Current output filter	0 to 5s	0.02s
870	Speed detection hysteresis	0 to 5Hz	0Hz
872	Input phase loss protection selection	0, 1	0
874	OLT level setting	0 to 400%	120/ 110% ^{*9}
882	Regeneration avoidance operation selection	0 to 2	0
883	Regeneration avoidance operation level	300 to 800V	380V DC/ 760V DC ^{*7}
884	Regeneration avoidance at deceleration detection sensitivity	0 to 5	0

Parameter	Name	Setting Range	Initial Value
885	Regeneration avoidance compensation frequency limit value	0 to 590Hz, 9999	6Hz
886	Regeneration avoidance voltage gain	0 to 200%	100%
888	Free parameter 1	0 to 9999	9999
889	Free parameter 2	0 to 9999	9999
891	Cumulative power monitor digit shifted times	0 to 4, 9999	9999
892	Load factor	30 to 150%	100%
893	Energy saving monitor reference (motor capacity)	0.1 to 55kW ^{*2}	LD/SLD rated inverter capacity ^{*9}
		0 to 3600kW ^{*3}	
894	Control selection during commercial power-supply operation	0 to 3	0
895	Power saving rate reference value	0, 1, 9999	9999
896	Power unit cost	0 to 500, 9999	9999
897	Power saving monitor average time	0, 1 to 1000h, 9999	9999
898	Power saving cumulative monitor clear	0, 1, 10, 9999	9999
899	Operation time rate (estimated value)	0 to 100%, 9999	9999
C0 (900) ^{*8}	FM/CA terminal calibration ^{*9}	—	—
C1 (901) ^{*8}	AM terminal calibration	—	—
C2 (902) ^{*8}	Terminal 2 frequency setting bias frequency	0 to 590Hz	0Hz
C3 (902) ^{*8}	Terminal 2 frequency setting bias	0 to 300%	0%
125 (903) ^{*8}	Terminal 2 frequency setting gain frequency	0 to 590Hz	60/50Hz ^{*9}
C4 (903) ^{*8}	Terminal 2 frequency setting gain	0 to 300%	100%
C5 (904) ^{*8}	Terminal 4 frequency setting bias frequency	0 to 590Hz	0Hz
C6 (904) ^{*8}	Terminal 4 frequency setting bias	0 to 300%	20%

^{*2} For FR-F820-02330(55K) or lower and FR-F840-01160(55K) or lower

^{*3} For FR-F820-03160(75K) or higher and FR-F840-01800(75K) or higher

^{*7} Differs according to the voltage class. (200V class/400V class)

^{*8} The parameter number in parentheses is the one for use with the parameter unit (FR-PU07).

^{*9} Differs according to types. (FM type/CA type)

^{*10} The setting is available only with the CA type.

Parameter	Name	Setting Range	Initial Value	Parameter	Name	Setting Range	Initial Value
126 (905) *8	Terminal 4 frequency setting gain frequency	0 to 590Hz	60/50Hz *9	C39 (932) *8	Terminal 4 bias (torque)	0 to 300%	20%
C7 (905) *8	Terminal 4 frequency setting gain	0 to 300%	100%	C40 (933) *8	Terminal 4 gain command (torque)	0 to 400%	150%
C12 (917) *8	Terminal 1 bias frequency (speed)	0 to 590Hz	0Hz	C41 (933) *8	Terminal 4 gain (torque)	0 to 300%	100%
C13 (917) *8	Terminal 1 bias (speed)	0 to 300%	0%	C42 (934) *8	PID display bias coefficient	0 to 500.00, 9999	9999
C14 (918) *8	Terminal 1 gain frequency (speed)	0 to 590Hz	60/50Hz *9	C43 (934) *8	PID display bias analog value	0 to 300.0%	20%
C15 (918) *8	Terminal 1 gain (speed)	0 to 300%	100%	C44 (935) *8	PID display gain coefficient	0 to 500.00, 9999	9999
C16 (919) *8	Terminal 1 bias command (torque)	0 to 400%	0%	C45 (935) *8	PID display gain analog value	0 to 300.0%	100%
C17 (919) *8	Terminal 1 bias (torque)	0 to 300%	0%	977	Input voltage mode selection	0, 1	0
C18 (920) *8	Terminal 1 gain command (torque)	0 to 400%	150%	989	Parameter copy alarm release	10 *2	10 *2
C19 (920) *8	Terminal 1 gain (torque)	0 to 300%	100%	990		100 *3	100 *3
C8 (930) *8,*10	Current output bias signal	0 to 100%	0%	991	PU buzzer control	0, 1	1
C9 (930) *8,*10	Current output bias current	0 to 100%	0%	992	PU contrast adjustment	0 to 63	58
C10 (931) *8,*10	Current output gain signal	0 to 100%	100%	992	Operation panel setting dial push monitor selection	0 to 3, 5 to 14, 17, 18, 20, 23 to 25, 34, 38, 40 to 45, 50 to 57, 61, 62, 64, 67, 68, 81 to 96, 98, 100	0
C11 (931) *8,*10	Current output gain current	0 to 100%	100%	997	Fault initiation	0 to 255, 9999	9999
C38 (932) *8	Terminal 4 bias command (torque)	0 to 400%	0%	998	PM parameter initialization	0, 12, 112, 8009, 8109, 9009, 9109	0
				999	Automatic parameter setting	1, 2, 10 to 13, 20, 21, 9999	9999
				1000	Parameter for manufacturer setting. Do not set.		
				1002	Lq tuning target current adjustment coefficient	50 to 150%, 9999	9999
				1006	Clock (year)	2000 to 2099	2000

*2 For FR-F820-02330(55K) or lower and FR-F840-01160(55K) or lower

*3 For FR-F820-03160(75K) or higher and FR-F840-01800(75K) or higher

*8 The parameter number in parentheses is the one for use with the parameter unit (FR-PU07).

*9 Differs according to types. (FM type/CA type).

*10 The setting is available only with the CA type.



Parameter	Name	Setting Range	Initial Value
1007	Clock (month, day)	101 to 131, 201 to 229, 301 to 331, 401 to 430, 501 to 531, 601 to 630, 701 to 731, 801 to 831, 901 to 930, 1001 to 1031, 1101 to 1130, 1201 to 1231	101
1008	Clock (hour, minute)	0 to 59, 100 to 159, 200 to 259, 300 to 359, 400 to 459, 500 to 559, 600 to 659, 700 to 759, 800 to 859, 900 to 959, 1000 to 1059, 1100 to 1159, 1200 to 1259, 1300 to 1359, 1400 to 1459, 1500 to 1559, 1600 to 1659, 1700 to 1759, 1800 to 1859, 1900 to 1959, 2000 to 2059, 2100 to 2159, 2200 to 2259, 2300 to 2359	0
1013	Emergency drive running speed after retry reset	0 to 590Hz	60/50Hz ^{*9}
1015	Integral stop selection at limited frequency	0, 1, 10, 11	0
1016	PTC thermistor protection detection time	0 to 60s	0s
1020	Trace operation selection	0 to 4	0
1021	Trace mode selection	0 to 2	0
1022	Sampling cycle	0 to 9	2
1023	Number of analog channels	1 to 8	4
1024	Sampling auto start	0, 1	0
1025	Trigger mode selection	0 to 4	0
1026	Number of sampling before trigger	0 to 100%	90%

Parameter	Name	Setting Range	Initial Value
1027	Analog source selection (1ch)	1 to 3, 5 to 14, 17, 18, 20, 23, 24, 34, 40 to 42, 52 to 54, 61, 62, 64, 67, 68, 81 to 96, 98, 201 to 213, 230 to 232, 237, 238	201
1028	Analog source selection (2ch)		202
1029	Analog source selection (3ch)		203
1030	Analog source selection (4ch)		204
1031	Analog source selection (5ch)		205
1032	Analog source selection (6ch)		206
1033	Analog source selection (7ch)		207
1034	Analog source selection (8ch)		208
1035	Analog trigger channel	1 to 8	1
1036	Analog trigger operation selection	0, 1	0
1037	Analog trigger level	600 to 1400	1000
1038	Digital source selection (1ch)	1 to 255	1
1039	Digital source selection (2ch)		2
1040	Digital source selection (3ch)		3
1041	Digital source selection (4ch)		4
1042	Digital source selection (5ch)		5
1043	Digital source selection (6ch)		6
1044	Digital source selection (7ch)		7
1045	Digital source selection (8ch)		8
1046	Digital trigger channel	1 to 8	1
1047	Digital trigger operation selection	0, 1	0
1048	Display-off waiting time	0 to 60min	0min
1049	USB host reset	0, 1	0
1106	Torque monitor filter	0 to 5s, 9999	9999
1107	Running speed monitor filter	0 to 5s, 9999	9999

^{*9} Differs according to types. (FM type/CA type)

Parameter	Name	Setting Range	Initial Value
1108	Excitation current monitor filter	0 to 5s, 9999	9999
1132	Pre-charge change increment amount	0 to 100%, 9999	9999
1133	Second pre-charge change increment amount	0 to 100%, 9999	9999
1134	Parameter for manufacturer setting. Do not set.		
1135			
1136	Second PID display bias coefficient	0 to 500, 9999	9999
1137	Second PID display bias analog value	0 to 300%	20%
1138	Second PID display gain coefficient	0 to 500, 9999	9999
1139	Second PID display gain analog value	0 to 300%	100%
1140	Second PID set point/deviation input selection	1 to 5	2
1141	Second PID measured value input selection	1 to 5, 101 to 105	3
1142	Second PID unit selection	0 to 43, 9999	9999
1143	Second PID upper limit	0 to 100%, 9999	9999
1144	Second PID lower limit	0 to 100%, 9999	9999
1145	Second PID deviation limit	0.0 to 100.0%, 9999	9999
1146	Second PID signal operation selection	0 to 3, 10 to 13	0
1147	Second output interruption detection time	0 to 3600s, 9999	1s
1148	Second output interruption detection level	0 to 590Hz	0Hz
1149	Second output interruption cancel level	900 to 1100%	1000%
1150 to 1199	User parameters 1 to 50	0 to 65535	0
1211	PID gain tuning timeout time	1 to 9999s	100s
1212	Step manipulated amount	900 to 1100%	1000%
1213	Step responding sampling cycle	0.01 to 600s	1s
1214	Timeout time after the maximum slope	1 to 9999s	10s
1215	Limit cycle output upper limit	900 to 1100%	1100%
1216	Limit cycle output lower limit	900 to 1100%	1000%

Parameter	Name	Setting Range	Initial Value			
1217	Limit cycle hysteresis	0.1 to 10%	1%			
1218	PID gain tuning setting	0, 100 to 102, 111, 112, 121, 122, 200 to 202, 211, 212, 221, 222	0			
1219	PID gain tuning start/status	(0), 1, 8, (9, 90 to 96)	0			
1300 to 1343	Communication option parameters					
1350 to 1359						
1460				PID multistage set point 1	0 to 100%, 9999	9999
1461				PID multistage set point 2		9999
1462	PID multistage set point 3	9999				
1463	PID multistage set point 4	9999				
1464	PID multistage set point 5	9999				
1465	PID multistage set point 6	9999				
1466	PID multistage set point 7	9999				
1469	Number of cleaning times monitor	0 to 255	0			
1470	Number of cleaning times setting	0 to 255	0			
1471	Cleaning trigger selection	0 to 15	0			
1472	Cleaning reverse rotation frequency	0 to 590Hz	30Hz			
1473	Cleaning reverse rotation operation time	0 to 3600s	9999			
1474	Cleaning forward rotation frequency	0 to 590Hz, 9999	9999			
1475	Cleaning forward rotation operation time	0 to 3600s, 9999	9999			
1476	Cleaning stop time	0 to 3600s	5s			
1477	Cleaning acceleration time	0 to 3600s, 9999	9999			
1478	Cleaning deceleration time	0 to 3600s, 9999	9999			
1479	Cleaning time trigger	0 to 6000hr	0			
1480	Load characteristics measurement mode	0, 1, (2, 3, 4, 5, 81, 82, 83, 84, 85)	0			
1481	Load characteristics load reference 1	0 to 400%, 8888, 9999	9999			
1482	Load characteristics load reference 2	0 to 400%, 8888, 9999	9999			
1483	Load characteristics load reference 3	0 to 400%, 8888, 9999	9999			



Parameter	Name	Setting Range	Initial Value
1484	Load characteristics load reference 4	0 to 400%, 8888, 9999	9999
1485	Load characteristics load reference 5	0 to 400%, 8888, 9999	9999
1486	Load characteristics maximum frequency	0 to 590Hz	60/50Hz ^{*9}
1487	Load characteristics minimum frequency	0 to 590Hz	6Hz
1488	Upper limit warning detection width	0 to 400%, 9999	20%
1489	Lower limit warning detection width	0 to 400%, 9999	20%
1490	Upper limit fault detection width	0 to 400%, 9999	9999
1491	Lower limit fault detection width	0 to 400%, 9999	9999
1492	Load status detection signal delay time / load reference measurement waiting time	0 to 60s	1s

Parameter	Name	Setting Range	Initial Value
Pr.CLR	Parameter clear	(0,) 1	0
ALL.CL	All parameter clear	(0,) 1	0
Err.CL	Fault history clear	(0,) 1	0
Pr.CPY	Parameter copy	(0,) 1 to 3	0
Pr.CHG	Initial value change list	—	—
IPM	IPM initialization	0, 12	0
AUTO	Automatic parameter setting	—	—
Pr.Md	Group parameter setting	(0,) 1, 2	0

^{*9} Differs according to types. (FM type/CA type)

7 TROUBLESHOOTING

When a fault occurs in the inverter, the protective function activates, and the PU display automatically changes to one of the fault or alarm indications listed on *page 41*.

If the fault does not correspond to any of the following errors or if you have any other problem, please contact your sales representative.

- Retention of alarm output signal.....When the magnetic contactor (MC) provided on the input side of the inverter is opened at the activation of the protective function, the inverter's control power will be lost and the alarm output will not be held.
- Alarm display.....When the protective function is activated, the operation panel display automatically switches to the fault or alarm indication.
- Resetting methodWhen a protective function of the inverter is activated, the inverter output is kept stopped. Unless reset, the inverter cannot restart. (Refer to *page 40*.)
- When the protective functions were activated, take an appropriate corrective action, then reset the inverter, and resume the operation. Not doing so may lead to an inverter fault and damage.

Inverter fault or alarm indications are roughly divided as below:

- Error Message
A message regarding operational fault and setting fault by the operation panel (FR-DU08) and parameter unit (FR-PU07) is displayed. The inverter does not shut off output.
- Warning
The inverter does not shut off output even when a warning is displayed. However, failure to take appropriate measures will lead to a fault.
- Alarm
The inverter does not shut off output. You can also output an alarm signal by making parameter setting.
- Fault
When the protective function is activated, the inverter output is shut off and a fault signal is output.

NOTES

- For the details of fault displays and other malfunctions, also refer to the Instruction Manual.
- Past eight faults can be displayed using the setting dial. (Refer to *page 24*.)



7.1 Reset method of protective function

The inverter can be reset by performing any of the following operations. Note that the internal thermal integrated value of the electronic thermal relay function and the number of retries are cleared (erased) by resetting the inverter. Inverter recovers about 1s after reset is cancelled.

Three different methods can be used to reset an inverter.

- Using the operation panel, press the STOP/RESET key to reset the inverter. (This may only be performed when a fault occurs.)

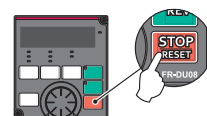

- Switch OFF the power once, then switch it ON again after the indicator of the operation panel turns OFF.

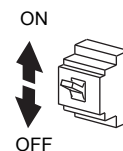

- Turn ON the reset signal (RES) for more than 0.1 s. (If the RES signal is kept ON, "Err." appears (flickers) to indicate that the inverter is in a reset status.)

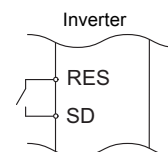

CAUTION

OFF status of the start signal must be confirmed before resetting the inverter fault. Resetting inverter fault with the start signal ON restarts the motor suddenly. This may cause injury.

7.2 List of alarm display

Operation Panel Indication		Name	Data code	
Error message	E-----	E-----	Faults history	—
	HOLD	HOLD	Operation panel lock	—
	LOCd	LOCd	Password locked	—
	Er1 to Er4 Er8	Er1 to Er4 Er8	Parameter write error	—
	rE1 to rE4 rE6 to rE8	rE1 to rE4 rE6 to rE8	Copy operation error	—
	Err.	Err.	Error	—
	Warning	OL	OL	Stall prevention (overcurrent)
oL		oL	Stall prevention (overvoltage)	—
TH		TH	Electronic thermal relay function pre-alarm	—
PS		PS	PU Stop	—
MT1 to MT3		MT1 to MT3	Maintenance signal output	—
CP		CP	Parameter copy	—
SA		SA	Safety stop	—
UF		UF	USB host error	—
EV		EV	24 V external power supply operation	—
Ed		ED	Emergency drive in operation	—
LdF		LDF	Load fault warning	—
Alarm	FN	FN	Fan alarm	—
Fault	E. OC1	E.OC1	Overcurrent trip during acceleration	16 (H10)
	E. OC2	E.OC2	Overcurrent trip during constant speed	17 (H11)
	E. OC3	E.OC3	Overcurrent trip during deceleration or stop	18 (H12)
	E. OV1	E.OV1	Regenerative overvoltage trip during acceleration	32 (H20)
	E. OV2	E.OV2	Regenerative overvoltage trip during constant speed	33 (H21)
	E. OV3	E.OV3	Regenerative overvoltage trip during deceleration or stop	34 (H22)
	E. THF	E.THT	Inverter overload trip (electronic thermal relay function)	48 (H30)
	E. THM	E.THM	Motor overload trip (electronic thermal relay function)	49 (H31)
	E. FIN	E.FIN	Heatsink overheat	64 (H40)
	E. IPF	E.IPF	Instantaneous power failure	80 (H50)
	E. UVF	E.UVT	Undervoltage	81 (H51)
	E. ILF	E.ILF	Input phase loss	82 (H52)
	E. OLF	E.OLT	Stall prevention stop	96 (H60)
	E. SOT	E. SOT	Loss of synchronism detection	97 (H61)

Operation Panel Indication		Name	Data code
E. LUP	E.LUP	Upper limit fault detection	98 (H62)
E. LDN	E.LDN	Lower limit fault detection	99 (H63)
E. bE	E.BE	Internal circuit fault	112 (H70)
E. GF	E.GF	Output side earth fault overcurrent	128 (H80)
E. LF	E.LF	Output phase loss	129 (H81)
E. OHT	E.OHT	External thermal relay operation	144 (H90)
E. PTC	E.PTC	PTC thermistor operation	145 (H91)
E. OPT	E.OPT	Option fault	160 (HA0)
E. OP1	E.OP1	Communication option fault	161 (HA1)
E. 16 to E. 20	E.16 to E.20	User definition error by the PLC function	164–168 (HA4–HA8)
E. PE	E.PE	Parameter storage device fault	176 (HB0)
E. PUE	E.PUE	PU disconnection	177 (HB1)
E. RET	E.RET	Retry count excess	178 (HB2)
E. PE2	E.PE2	Parameter storage device fault	179 (HB3)
E. CPU	E.CPU	CPU fault	192 (HC0)
E. CTE	E.CTE	Operation panel power supply short circuit/RS-485 terminal power supply short circuit	193 (HC1)
E. P24	E.P24	24V DC power fault	194 (HC2)
E. CDO	E.CDO	Abnormal output current detection	196 (HC4)
E. IOH	E.IOH	Inrush current limit circuit fault	197 (HC5)
E. SER	E.SER	Communication fault (inverter)	198 (HC6)
E. AIE	E.AIE	Analog input fault	199 (HC7)
E. USB	E.USB	USB communication fault	200 (HC8)
E. SAF	E.SAF	Safety circuit fault	201 (HC9)
E. PBT	E.PBT	Internal circuit fault	202 (HCA)
E. OS	E.OS	Overspeed occurrence	208 (HD0)
E. LCI	E.LCI	4mA input fault	228 (HE4)
E. PCH	E.PCH	Pre-charge fault	229 (HE5)
E. PID	E.PID	PID signal fault	230 (HE6)
E. 1 to E. 3	E. 1 to E. 3	Option fault	241–243 (HF1–HF3)
E. 5 to E. 7	E. 5 to E. 7	CPU fault	245–247 (HF5–HF7)
E. 13	E.13	Internal circuit fault	253 (HFD)

If faults other than the above appear, contact your sales representative.

8 SPECIFICATIONS

8.1 Rating

8.1.1 200V class

Model FR-F820-□		00046 (0.75K)	00077 (1.5K)	00105 (2.2K)	00167 (3.7K)	00250 (5.5K)	00340 (7.5K)	00490 (11K)	00630 (15K)	00770 (18.5K)	00930 (22K)	01250 (30K)	01540 (37K)	01870 (45K)	02330 (55K)	03160 (75K)	03800 (90K)	04750 (110K)
Applicable motor capacity [kW] *1	SLD	0.75	1.5	2.2	3.7	5.5	7.5	11	15	18.5	22	30	37	45	55	75	110	132
	LD	0.75	1.5	2.2	3.7	5.5	7.5	11	15	18.5	22	30	37	45	55	75	90	110
Rated capacity [kVA] *2	SLD	1.8	2.9	4	6.4	10	13	19	24	29	35	48	59	71	89	120	145	181
	LD	1.6	2.7	3.7	5.8	8.8	12	17	22	27	32	43	53	65	81	110	132	165
Rated current [A]	SLD	4.6	7.7	10.5	16.7	25	34	49	63	77	93	125	154	187	233	316	380	475
	LD	4.2	7	9.6	15.2	23	31	45	58	70.5	85	114	140	170	212	288	346	432
Overload current rating *3	SLD	110% of rated motor capacity for 60s, 120% of rated motor capacity for 3s (max. surrounding air temperature 40°C)																
	LD	120% of rated motor capacity for 60s, 150% of rated motor capacity for 3s (max. surrounding air temperature 50°C)																
Rated voltage *4		Three-phase 200 to 240V																
Rated input AC voltage/frequency		Three-phase 200 to 240V 50Hz/60Hz																
Permissible AC voltage fluctuation		170 to 264V 50Hz/60Hz																
Permissible frequency fluctuation		±5%																
Rated input current [A] *5	SLD	5.3	8.9	13.2	19.7	31.3	45.1	62.8	80.6	96.7	115	151	185	221	269	316	380	475
	LD	5	8.3	12.2	18.3	28.5	41.6	58.2	74.8	90.9	106	139	178	207	255	288	346	432
Power supply capacity [kVA] *6	SLD	2	3.4	5	7.5	12	17	24	31	37	44	58	70	84	103	120	145	181
	LD	1.9	3.2	4.7	7	11	16	22	29	35	41	53	68	79	97	110	132	165
Protective structure (IEC 60529) *7		IP20											IP00					
Cooling system		Self-cooling			Forced air cooling													
Weight [kg]		1.9	2.1	3.0	3.0	3.0	6.3	6.3	8.3	15	15	15	22	42	42	54	74	74

*1 The applicable motor capacity indicated is the maximum capacity applicable for use of the Mitsubishi Electric 4-pole standard motor.

*2 The rated output capacity indicated assumes that the output voltage is 220V.

*3 The % value of the overload current rating indicated is the ratio of the overload current to the inverter's rated output current. For repeated duty, allow time for the inverter and motor to return to or below the temperatures under 100% load.

*4 The maximum output voltage does not exceed the power supply voltage. The maximum output voltage can be changed within the setting range. However, the maximum point of the voltage waveform at the inverter output side is the power supply voltage multiplied by about $\sqrt{2}$.

*5 The rated input current indicates a value at a rated output voltage. The impedance at the power supply side (including those of the input reactor and cables) affects the rated input current.

*6 The power supply capacity is the value when at the rated output current. It varies by the impedance at the power supply side (including those of the input reactor and cables).

*7 FR-DU08: IP40 (except for the PU connector section)

8.1.2 400V class

Model FR-F840-□		00023 (0.75K)	00038 (1.5K)	00052 (2.2K)	00083 (3.7K)	00126 (5.5K)	00170 (7.5K)	00250 (11K)	00310 (15K)	00380 (18.5K)	00470 (22K)	00620 (30K)	00770 (37K)	00930 (45K)	01160 (55K)	01800 (75K)	02160 (90K)	02600 (110K)	03250 (132K)	03610 (160K)	04320 (185K)	04810 (220K)	05470 (250K)	06100 (280K)	06830 (315K)	
Applicable motor capacity [kW] *1	SLD	0.75	1.5	2.2	3.7	5.5	7.5	11	15	18.5	22	30	37	45	55	75	110	132	160	185	220	250	280	315	355	
	LD	0.75	1.5	2.2	3.7	5.5	7.5	11	15	18.5	22	30	37	45	55	75	90	110	132	160	185	220	250	280	315	
Rated capacity [kVA] *2	SLD	1.8	2.9	4	6.3	10	13	19	24	29	36	47	59	71	88	137	165	198	248	275	329	367	417	465	521	
	LD	1.6	2.7	3.7	5.8	8.8	12	18	22	27	33	43	53	65	81	110	137	165	198	248	275	329	367	417	465	
Rated current [A]	SLD	2.3	3.8	5.2	8.3	12.6	17	25	31	38	47	62	77	93	116	180	216	260	325	361	432	481	547	610	683	
	LD	2.1	3.5	4.8	7.6	11.5	16	23	29	35	43	57	70	85	106	144	180	216	260	325	361	432	481	547	610	
Overload current rating *3	SLD	110% of rated motor capacity for 60s, 120% of rated motor capacity for 3s (max. surrounding air temperature 40°C)																								
	LD	120% of rated motor capacity for 60s, 150% of rated motor capacity for 3s (max. surrounding air temperature 50°C)																								
Rated voltage *4	Three-phase 380 to 500V																									
Rated input AC voltage/frequency	Three-phase 380 to 500V 50Hz/60Hz *8																									
Permissible AC voltage fluctuation	323 to 550V 50Hz/60Hz																									
Permissible frequency fluctuation	±5%																									
Rated input current [A] *5	SLD	3.2	5.4	7.8	10.9	16.4	22.5	31.7	40.3	48.2	58.4	76.8	97.6	115	141	180	216	260	325	361	432	481	547	610	683	
	LD	3	4.9	7.3	10.1	15.1	22.3	31	38.2	44.9	53.9	75.1	89.7	106	130	144	180	216	260	325	361	432	481	547	610	
Power supply capacity [kVA] *6	SLD	2.5	4.1	5.9	8.3	12	17	24	31	37	44	59	74	88	107	137	165	198	248	275	329	367	417	465	521	
	LD	2.3	3.7	5.5	7.7	12	17	24	29	34	41	57	68	81	99	110	137	165	198	248	275	329	367	417	465	
Protective structure (IEC 60529) *7	IP20												IP00													
Cooling system	Self-cooling					Forced air cooling																				
Weight [kg]	2.5	2.5	2.5	3.0	3.0	6.3	6.3	8.3	8.3	15	15	23	41	41	43	52	55	71	78	117	117	166	166	166	166	

*1 The applicable motor capacity indicated is the maximum capacity applicable for use of the Mitsubishi Electric 4-pole standard motor.
 *2 The rated output capacity indicated assumes that the output voltage is 440V.
 *3 The % value of the overload current rating indicated is the ratio of the overload current to the inverter's rated output current. For repeated duty, allow time for the inverter and motor to return to or below the temperatures under 100% load.
 *4 The maximum output voltage does not exceed the power supply voltage. The maximum output voltage can be changed within the setting range. However, the maximum point of the voltage waveform at the inverter output side is the power supply voltage multiplied by about $\sqrt{2}$.
 *5 The rated input current indicates a value at a rated output voltage. The impedance at the power supply side (including those of the input reactor and cables) affects the rated input current.
 *6 The power supply capacity is the value when at the rated output current. It varies by the impedance at the power supply side (including those of the input reactor and cables).
 *7 FR-DU08: IP40 (except for the PU connector section)
 *8 For the power voltage exceeding 480V, set Pr. 977 "Input voltage mode selection". (For details, refer to the Instruction Manual.)

A APPENDIX

A.1 Instructions for Compliance with the EU Directives

The EU Directives are issued to standardize different national regulations of the EU Member States and to facilitate free movement of the equipment, whose safety is ensured, in the EU territory.

Since 1996, compliance with the EMC Directive that is one of the EU Directives has been legally required. Since 1997, compliance with the Low Voltage Directive, another EU Directive, has been also legally required. When a manufacturer confirms its equipment to be compliant with the EMC Directive and the Low Voltage Directive, the manufacturer must declare the conformity and affix the CE marking.

- The authorized representative in the EU
Name: Mitsubishi Electric Europe B.V.
Address: Gothaer Straße 8, 40880 Ratingen, Germany

NOTE

We declare that this inverter conforms with the EMC Directive in industrial environments and affix the CE marking on the inverter. When using the inverter in a residential area, take appropriate measures and ensure the conformity of the inverter used in the residential area.

A.1.1 EMC Directive

We declare that this inverter conforms with the EMC Directive and affix the CE marking on the inverter.

- EMC Directive: 2004/108/EC
- Standard(s): EN61800-3:2004 (Second environment / PDS Category "C3")
- This inverter is not intended to be used on a low-voltage public network which supplies domestic premises.
- Radio frequency interference is expected if used on such a network.
- The installer shall provide a guide for installation and use, including recommended mitigation devices.

NOTES

- First environment
Environment including residential buildings. Includes buildings directly connected without a transformer to the low voltage power supply network which supplies power to residential buildings.
- Second environment
Environment including all buildings except buildings directly connected without a transformer to the low voltage power supply network which supplies power to residential buildings.

NOTES

Set the EMC filter valid and install the inverter and perform wiring according to the following instructions:

- The inverter is equipped with a built-in EMC filter. Set the EMC filter valid.
(For details, refer to the Instruction Manual.)
- Connect the inverter to an earthed power supply.
- Install a motor and a control cable according to the EMC Installation Guidelines (BCN-A21041-204) and Technical News (MF-S-114, 115) according to the instruction.
- Confirm that the inverter conforms with the EMC Directive as the industrial drives application for final installation.

A.1.2 Low Voltage Directive

We have self-confirmed our inverters as products compliant to the Low Voltage Directive (conforming standard EN 61800-5-1) and place the CE mark on the inverters.

Outline of instructions

- Do not use an earth leakage current breaker as an electric shock protector without connecting the equipment to the earth. Connect the equipment to the earth securely.
- Wire the earth terminal independently. (Do not connect two or more cables to one terminal.)
- Use the cable sizes on *page 10* under the following conditions.
 - Surrounding air temperature: 40°C maximum
 - If conditions are different from above, select appropriate wire according to EN60204 Appendix C TABLE 5.
- Use a tinned (plating should not include zinc) crimping terminal to connect the earth cable. When tightening the screw, be careful not to damage the threads.
For use as a product compliant with the Low Voltage Directive, use PVC cable whose size is indicated on *page 10*.
- Use the moulded case circuit breaker and magnetic contactor which conform to the EN or IEC Standard.
- This product can cause a DC current in the protective earthing conductor. Where a residual current-operated protective (RCD) or monitoring (RCM) device is used for protection in case of direct or indirect contact, only an RCD or RCM of Type B is allowed on the supply side of this product.
- Use the inverter under the conditions of overvoltage category II (usable regardless of the earth condition of the power supply), overvoltage category III (usable with the earthed-neutral system power supply, 400V class only) and pollution degree 2 or lower specified in IEC 60664. An insulating transformer needs to be installed in the input side of the FR-F820 series inverters.
 - To use the inverter FR-F820-01250(30K) or more and FR-F840-00770(37K) or more (IP00) under the conditions of pollution degree 2, install it in the enclosure of IP 2X or higher.
 - To use the inverter under the conditions of pollution degree 3, install it in the enclosure of IP54 or higher.
 - To use the inverter FR-F820-00930(22K) or less and FR-F840-00620(30K) or less (IP20) outside of an enclosure in the environment of pollution degree 2, fix a fan cover with fan cover fixing screws enclosed.

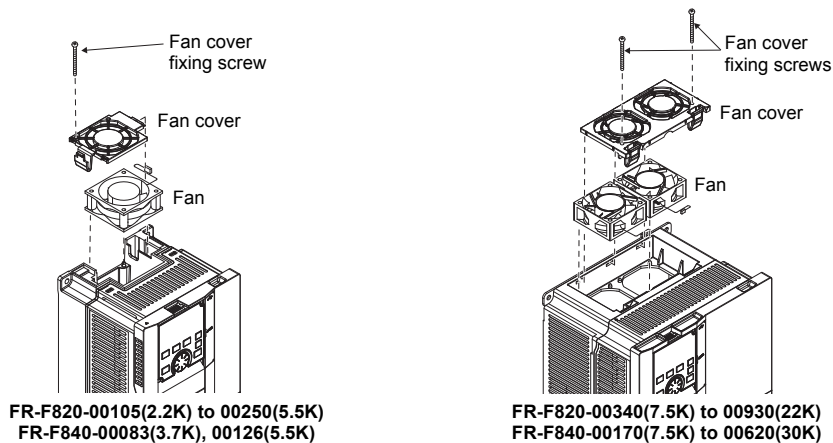

- On the input and output of the inverter, use cables of the type and size set forth in EN60204 Appendix C.
- The operating capacity of the relay outputs (terminal symbols A1, B1, C1, A2, B2, C2) should be 30VDC, 0.3A. (Relay outputs are basically isolated from the inverter internal circuit.)
- Control circuit terminals on *page 4* are safely isolated from the main circuit.
- Environment

	During Operation	In Storage	During Transportation
Surrounding air temperature	LD rating: -10 to +50°C SLD rating: -10 to +40°C	-20 to +65°C	-20 to +65°C
Ambient humidity	95% RH or less	95% RH or less	95% RH or less
Maximum altitude	2500m	2500m	10000m



Wiring protection

For installation Class T, Class J, or Class CC fuse or UL 489 Molded Case Circuit Breaker (MCCB) according to the local directives must be provided.

FR-F820-□		00046 (0.75K)	00077 (1.5K)	00105 (2.2K)	00167 (3.7K)	00250 (5.5K)	00340 (7.5K)	00490 (11K)	00630 (15K)	00770 (18.5K)	00930 (22K)	01250 (30K)	01540 (37K)
Rated fuse voltage [V]		240V or more											
Fuse Maximum allowable rating [A] *1	Without power factor improving reactor	15	20	30	40	60	80	150	175	200	225	300	350
	With power factor improving reactor	15	20	20	30	50	70	125	150	200	200	250	300
Molded case circuit breaker (MCCB) Maximum allowable rating [A] *1		15	15	25	40	60	80	110	150	190	225	300	350

FR-F820-□		01870 (45K)	02330 (55K)	03160 (75K)	03800 (90K)	04750 (110K)
Rated fuse voltage [V]		240V or more				
Fuse Maximum allowable rating [A] *1	Without power factor improving reactor	400	500	—	—	—
	With power factor improving reactor	350	400	500	600	700
Molded case circuit breaker (MCCB) Maximum allowable rating [A] *1		450	500	700	900	1000

FR-F840-□		00023 (0.75K)	00038 (1.5K)	00052 (2.2K)	00083 (3.7K)	00126 (5.5K)	00170 (7.5K)	00250 (11K)	00310 (15K)	00380 (18.5K)	00470 (22K)	00620 (30K)	00770 (37K)
Rated fuse voltage [V]		500V or more											
Fuse Maximum allowable rating [A] *1	Without power factor improving reactor	6	10	15	20	30	40	70	80	90	110	150	175
	With power factor improving reactor	6	10	10	15	25	35	60	70	90	100	125	150
Molded case circuit breaker (MCCB) Maximum allowable rating [A] *1		15	15	15	20	30	40	60	70	90	100	150	175

FR-F840-□		00930 (45K)	01160 (55K)	01800 (75K)	02160 (90K)	02600 (110K)	03250 (132K)	03610 (160K)	04320 (185K)	04810 (220K)	05470 (250K)	06100 (280K)	06830 (315K)
Rated fuse voltage [V]		500V or more											
Fuse Maximum allowable rating [A] *1	Without power factor improving reactor	200	250	—	—	—	—	—	—	—	—	—	—
	With power factor improving reactor	175	200	250	300	350	400	500	600	700	800	900	1000
Molded case circuit breaker (MCCB) Maximum allowable rating [A] *1		225	250	450	450	500	—	—	—	—	—	—	—

*1 Maximum allowable rating by US National Electrical Code. Exact size must be chosen for each installation.

A.1.3 Short circuit ratings

- 200V class
Suitable for use in a circuit capable of delivering not more than 100kA rms symmetrical amperes, 264V maximum.
- 400V class
Suitable for use in a circuit capable of delivering not more than 100kA rms symmetrical amperes, 550V or 600V maximum.

A.1.4 Machinery directive

The frequency inverter itself is not a machine in the spirit of the EU machinery directive. The start up of the frequency inverter in a machine is prohibited so long until it has been confirmed that the entire machine complies with the provisions of Directive 98/37/EC (from 29.12.2009 Machinery Directive 2006/42/EC).

A.2 Instructions for UL and cUL

(Conforming standard UL 508C, CSA C22.2 No.14)

A.2.1 General precautions

⚠ WARNING

The bus capacitor discharge time is 10 minutes. Before starting wiring or inspection, switch power off, wait for more than 10 minutes, and check for residual voltage between terminal P/+ and N/- with a meter etc., to avoid a hazard of electrical shock.

A.2.2 Installation

These types of inverter have been approved as products for use in enclosure and approval tests were conducted under the following conditions.

Design an enclosure so that the inverter surrounding air temperature, humidity and atmosphere satisfy the specifications. (Refer to *page 2*.)

Wiring protection

For installation in the United States, Class T, Class J, or Class CC fuse or UL 489 Molded Case Circuit Breaker (MCCB) must be provided in accordance with the National Electrical Code and any applicable provincial codes (refer to the tables on *page 46*).

For installation in Canada, Class T, Class J, or Class CC fuse or UL 489 Molded Case Circuit Breaker (MCCB) must be provided in accordance with the Canada Electrical Code and any applicable provincial codes (refer to the tables on *page 46*).

A.2.3 Wiring of the power supply and motor

For wiring the input (R/L1, S/L2, T/L3) and output (U, V, W) terminals of the inverter, use the UL-listed copper wires (rated at 75°C) and round crimping terminals. Crimp the crimping terminals with the crimping tool recommended by the terminal maker.

A.2.4 Short circuit ratings

- 200V class
Suitable for use in a circuit capable of delivering not more than 100kA rms symmetrical amperes, 264V maximum.
- 400V class
Suitable for use in a circuit capable of delivering not more than 100kA rms symmetrical amperes, 550V or 600V maximum.



A.2.5 Motor overload protection

When using the electronic thermal relay function as motor overload protection, set the rated motor current to Pr. 9 "Electronic thermal O/L relay".

Electronic thermal relay function operation characteristic (LD rating)

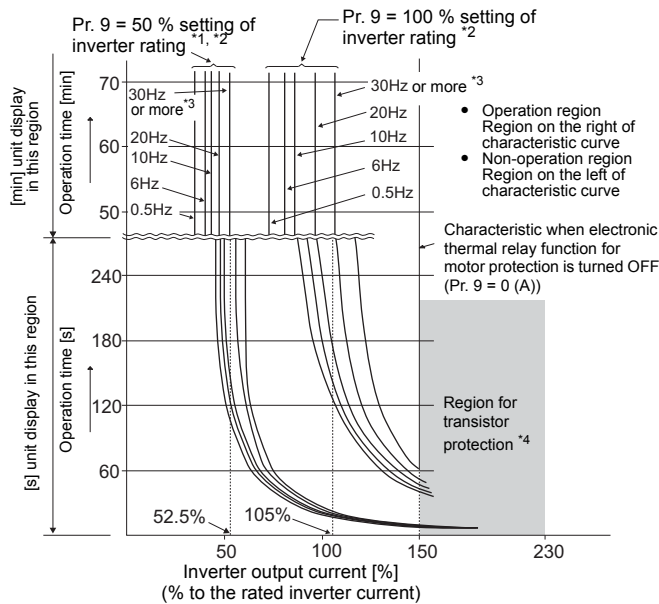

This function detects the overload (overheat) of the motor, stops the operation of the inverter's output transistor, and stops the output. (The operation characteristic is shown on the left.)

When using the Mitsubishi Electric constant-torque motor set one of "1", "13" to "16", "50", "53", "54" in Pr. 71. This provides a 100 % continuous torque characteristic in the low-speed range. Set the rated current of the motor in Pr. 9.

^{*1} When 50% of the inverter rated output current (current value) is set in Pr. 9.

^{*2} The % value denotes the percentage to the inverter rated output current. It is not the percentage to the motor rated current.

^{*3} When you set the electronic thermal relay function dedicated to the Mitsubishi Electric constant-torque motor, this characteristic curve applies to operation at 6 Hz or higher.

^{*4} Transistor protection is activated depending on the temperature of the heatsink. The protection may be activated even with less than 120% depending on the operating conditions.

CAUTION

- The internal accumulated heat value of the electronic thermal relay function is reset by inverter power reset and reset signal input. Avoid unnecessary reset and power-OFF.
- When using multiple motors with one inverter, or using a multi-pole motor or a specialized motor, provide an external thermal relay (OCR) between the inverter and motor. And for the setting of the thermal relay, add the line-to line leakage current to the current value on the motor rating plate (details in the Instruction Manual). For low-speed operation where the cooling capability of the motor reduces, it is recommended to use a thermal protector or thermistor-incorporated motor.
- When the difference between the inverter and motor capacities is large and the setting is small, the protective characteristics of the electronic thermal relay function will be deteriorated. In this case, use an external thermal relay.
- A special motor cannot be protected by the electronic thermal relay function. Use an external thermal relay.
- Electronic thermal relay may not operate when 5% or less of rated inverter current is set to electronic thermal relay setting.
- Motor over temperature sensing is not provided by the drive.

HEADQUARTERS		EUROPEAN REPRESENTATIVES		EUROPEAN REPRESENTATIVES		EURASIAN REPRESENTATIVES	
Mitsubishi Electric Europe B.V. Gothaer Straße 8 D-40880 Ratingen Phone: +49 (0)2102 / 486-0 Fax: +49 (0)2102 / 486-1120	EUROPE	GEVA Wiener Straße 89 A-2500 Baden Phone: +43 (0)2252 / 85 55 20 Fax: +43 (0)2252 / 488 60	AUSTRIA	Beijer Electronics UAB Goštautų g. 3 LT-48324 Kaunas Phone: +370 37 262707 Fax: +370 37 455605	LITHUANIA	TOO Kazpromavtomatika UL. ZHAMBYLA 28, KAZ-100017 Karaganda Phone: +7 7212 / 50 10 00 Fax: +7 7212 / 50 11 50	KAZAKHSTAN
Mitsubishi Electric Europe B.V. Radlická 751/113e Avenir Business Park CZ-158 00 Praha 5 Phone: +420 251 551 470 Fax: +420 251 551 471	CZECH REP.	000 TECHNIKON Prospect Nezavisimosti 177-9 BY-220125 Minsk Phone: +375 (0)17 / 393 1177 Fax: +375 (0)17 / 393 0081	BELARUS	ALFATRADE Ltd. 99, Paola Hill Malta-Paola PLA 1702 Phone: +356 (0)21 / 697 816 Fax: +356 (0)21 / 697 817	MALTA	MIDDLE EAST REPRESENTATIVE	
Mitsubishi Electric Europe B.V. 25, Boulevard des Bouvets F-92741 Nanterre Cedex Phone: +33 (0)1 / 55 68 55 68 Fax: +33 (0)1 / 55 68 57 57	FRANCE	ESCO DRIVES Culliganlaan 3 BE-1831 Diegem Phone: +32 (0)2 / 717 64 60 Fax: +32 (0)2 / 717 64 61	BELGIUM	INTEHSIS SRL bld. Traian 23/1 MD-2060 Kishinev Phone: +373 (0)22 / 66 4242 Fax: +373 (0)22 / 66 4280	MOLDOVA	I.C. SYSTEMS Ltd. 23 Al-Saad-Al-Alee St. EG-Sarayat, Maadi, Cairo Phone: +20 (0) 2 / 235 98 548 Fax: +20 (0) 2 / 235 96 625	EGYPT
Mitsubishi Electric Europe B.V. Westgate Business Park, Ballymount IRL-Dublin 24 Phone: +353 (0)1 4198800 Fax: +353 (0)1 4198890	IRELAND	KONING & HARTMAN B.V. Woluwelaan 31 BE-1800 Vilvoorde Phone: +32 (0)2 / 257 02 40 Fax: +32 (0)2 / 257 02 49	BELGIUM	HIFLEX AUTOM. B.V. Wolweverstraat 22 NL-2984 CD Ridderkerk Phone: +31 (0)180 / 46 60 04 Fax: +31 (0)180 / 44 23 55	NETHERLANDS	SHERF Motion Techn. Ltd. Rehov Hamerkava 19 IL-58851 Holon Phone: +972 (0)3 / 559 54 62 Fax: +972 (0)3 / 556 01 82	ISRAEL
Mitsubishi Electric Europe B.V. Viale Colleoni 7 Palazzo Sirio I-20864 Agrate Brianza (MB) Phone: +39 039 / 60 53 1 Fax: +39 039 / 60 53 312	ITALY	INEA RBT d.o.o. Stegne 11 SI-1000 Ljubljana Phone: +386 (0)1 / 513 8116 Fax: +386 (0)1 / 513 8170	BOSNIA AND HERZEGOVINA	IMTECH MARINE & OFFSHORE B.V. Sluisjesdijk 155 NL-3087 AG Rotterdam Phone: +31 (0)10 / 487 19 11 Fax: +31 (0)10 / 487 1692	NETHERLANDS	CEG LIBAN Cebaco Center/Block A Autostrade DORA Lebanon-Beirut Phone: +961 (0)1 / 240 445 Fax: +961 (0)1 / 240 193	LEBANON
Mitsubishi Electric Europe B.V. Nijverheidsweg 23a NL-3641RP Mijdrecht Phone: +31 (0) 297250350	NETHERLANDS	AKHNATON 4, Andrei Ljapchev Blvd., PO Box 21 BG-1756 Sofia Phone: +359 (0)2 / 817 6000 Fax: +359 (0)2 / 97 44 06 1	BULGARIA	KONING & HARTMAN B.V. Energieweg 1 NL-2627 AP Delft Phone: +31 (0)15 260 99 06 Fax: +31 (0)15 261 9194	NETHERLANDS	AFRICAN REPRESENTATIVE	
Mitsubishi Electric Europe B.V. ul. Krakowska 50 PL-32-083 Balice Phone: +48 (0) 12 347 65 00 Fax: +48 (0) 12 347 65 01	POLAND	INEA CR Losinjska 4 a HR-10000 Zagreb Phone: +385 (0)1 / 36 940 - 01 / -02 / -03 Fax: +385 (0)1 / 36 940 - 03	CROATIA	Beijer Electronics AS Postboks 487 NO-3002 Drammen Phone: +47 (0)32 / 24 30 00 Fax: +47 (0)32 / 84 85 77	NORWAY	ADROIT TECHNOLOGIES 20 Waterford Office Park 189 Witkoppen Road ZA-Fourways Phone: +27 (0)11 / 658 8100 Fax: +27 (0)11 / 658 8101	SOUTH AFRICA
Mitsubishi Electric Europe B.V. 52, bld. 1 Kosmodamianskaya emb. RU-115054 Moscow Phone: +7 495 / 721 2070 Fax: +7 495 / 721 2071	RUSSIA	AutoCont C. S. S.R.O. Kačkova 1853/3 CZ-702 00 Ostrava 2 Phone: +420 595 691 150 Fax: +420 595 691 199	CZECH REPUBLIC	Fonseca S.A. R. João Francisco do Casal 87/89 PT-3801-997 Aveiro, Esigueira Phone: +351 (0)234 / 303 900 Fax: +351 (0)234 / 303 910	PORTUGAL		
Mitsubishi Electric Europe B.V. Carretera de Rubi 76-80 Apdo. 420 E-08190 Sant Cugat del Vallés (Barcelona) Phone: +34 (0) 93 / 5653131 Fax: +34 (0) 93 / 5891579	SPAIN	Beijer Electronics A/S Lykkegardsvej 17 DK-4000 Roskilde Phone: +45 (0)46 / 75 76 66 Fax: +45 (0)46 / 75 56 26	DENMARK	SIRIUS TRADING & SERVICES SRL Aleea Lacul Morii Nr. 3 RO-060841 Bucuresti, Sector 6 Phone: +40 (0)21 / 430 40 06 Fax: +40 (0)21 / 430 40 02	ROMANIA		
Mitsubishi Electric Europe B.V. (Scandinavia) Fjellievägen 8 SE-22736 Lund Phone: +46 (0) 8 625 10 00 Fax: +46 (0) 46 39 70 18	SWEDEN	HANS FÖLSGAARD A/S Theilgaardstr. 1 DK-4600 Køge Phone: +45 4320 8600 Fax: +45 4396 8855	DENMARK	INEA SR d.o.o. Ul. Karadjordjeva 12/217 SER-11300 Smederevo Phone: +386 (0)26 / 461 54 01	SERBIA		
Mitsubishi Electric Turkey Elektrik Ürünleri A.Ş. Fabrika Otomasyon Merkezi Şerifali Mahallesi Nutuk Sokak No.5 TR-34775 Ümraniye-İSTANBUL Phone: +90 (0)216 / 526 39 90 Fax: +90 (0)216 / 526 39 95	TURKEY	Beijer Electronics Eesti OÜ Pärnu mnt. 160i EE-11317 Tallinn Phone: +372 (0)6 / 51 81 40 Fax: +372 (0)6 / 51 81 49	ESTONIA	SIMAP SK (Západné Slovensko) Jána Derku 1671 SK-911 01 Trenčín Phone: +421 (0)32 743 04 72 Fax: +421 (0)32 743 75 20	SLOVAKIA		
Mitsubishi Electric Europe B.V. Travellers Lane UK-Hatfield, Herts. AL10 8XB Phone: +44 (0)1707 / 28 87 80 Fax: +44 (0)1707 / 27 86 95	UK	Beijer Electronics OY Vanha Nurmijärventie 62 FIN-01670 Vantaa Phone: +358 (0)207 / 463 500 Fax: +358 (0)207 / 463 501	FINLAND	INEA RBT d.o.o. Stegne 11 SI-1000 Ljubljana Phone: +386 (0)1 / 513 8116 Fax: +386 (0)1 / 513 8170	SLOVENIA		
Mitsubishi Electric Europe B.V. Dubai Silicon Oasis United Arab Emirates - Dubai Phone: +971 4 3724716 Fax: +971 4 3724721	UAE	PROVENDOR OY Teljänkatu 8 A3 FIN-28130 Pori Phone: +358 (0) 2 / 522 3300 Fax: +358 (0) 2 / 522 3322	FINLAND	Beijer Electronics Automation AB Box 426 SE-20124 Malmö Phone: +46 (0)40 / 35 86 00 Fax: +46 (0)40 / 93 23 01	SWEDEN		
Mitsubishi Electric Corporation Tokyo Building 2-7-3 Marunouchi, Chiyoda-ku Tokyo 100-8310 Phone: +81 (3) 3218-2111 Fax: +81 (3) 3218-2185	JAPAN	UTECO A.B.E.E. 5, Mavrogenous Str. GR-18542 Piraeus Phone: +30 (0)211 / 1206-900 Fax: +30 (0)211 / 1206-999	GREECE	OMNI RAY AG Im Schörl 5 CH-8600 Dübendorf Phone: +41 (0)44 / 802 28 80 Fax: +41 (0)44 / 802 28 28	SWITZERLAND		
Mitsubishi Electric Automation, Inc. 500 Corporate Woods Parkway Vernon Hills, IL 60061 Phone: +1 (847) 478-2100 Fax: +1 (847) 478-0328	USA	MELTRADE Kft. Fertő utca 14. HU-1107 Budapest Phone: +36 (0)1 / 431-9726 Fax: +36 (0)1 / 431-9727	HUNGARY	OOO "CSC-AUTOMATION" 4-B, M. Raskovoyi St. UA-02660 Kiev Phone: +380 (0)44 / 494 33 44 Fax: +380 (0)44 / 494-33-66	UKRAINE		
		Beijer Electronics SIA Ritausmas iela 23 LV-1058 Riga Phone: +371 (0)6 / 784 2280 Fax: +371 (0)6 / 784 2281	LATVIA				