

### Main

Range of product	Preventa Safety detection
Product or component type	Preventa RFID safety switch
Component name	XCSRC

### Complementary

Design	Rectangular, standard
Size	50 x 15 x 15 mm transponder 108.3 x 30 x 15 mm reader
Material	Valox
Electrical connection	1 male connector
Connector type	M12 male
Type of output stage	Solid-state, PNP
Safety outputs	2 NO
Number of poles	5
Local signalling	2 multi-colour LEDs green, orange and red
[Sa] assured operating distance	10 mm face to face
[Sar] assured tripping distance	35 mm face to face
Approach directions	3 directions-transponder with rotary sensing face
[Ue] rated operational voltage	24 V DC (- 20...10 %) SELV or PELV conforming to EN/IEC 60204-1
[Ie] rated operational current	60 mA
[Ui] rated insulation voltage	30 V DC
[Uimp] rated impulse withstand voltage	0.8 kV IEC 60947-5-2
Protection type	Short-circuit protection
Maximum switching voltage	26.4 V DC
Switching capacity in mA	200 mA
Switching frequency	<= 0.5 Hz
Discordance time	<= 120 ms
Response time	120 ms typical
Delay first up	5 s
Tightening torque	<= 1.5 N.m
Standards	ISO 14119 EN/IEC 60947-5-2 EN/IEC 60947-5-3
Product certifications	Ecolab CSA 22-2 EAC E2 RCM TÜV IC FCC

Marking	FCC CULus RCM EAC CE IC TÜV
Safety level	SIL 3 EN/IEC 61508 SILCL 3 EN/IEC 62061 PL = e EN/ISO 13849-1 Category 4 EN/ISO 13849-1
Safety reliability data	PFH<SUB>D</SUB> = 5E-10/h EN/IEC 62061 PFH<SUB>D</SUB> = 5E-10/h EN/ISO 13849-1
Service life	20 yr
Ambient air temperature for operation	-25...70 °C
Ambient air temperature for storage	-40...85 °C
Vibration resistance	10 gn 10...150 Hz EN/IEC 60068-2-6
Shock resistance	30 gn 11 ms EN/IEC 60068-2-27
Electrical shock protection class	Class III EN/IEC 61140
IP degree of protection	IP65 EN/IEC 60529 IP66 EN/IEC 60529 IP67 EN/IEC 60529 IP69K DIN 40050

Dimensions

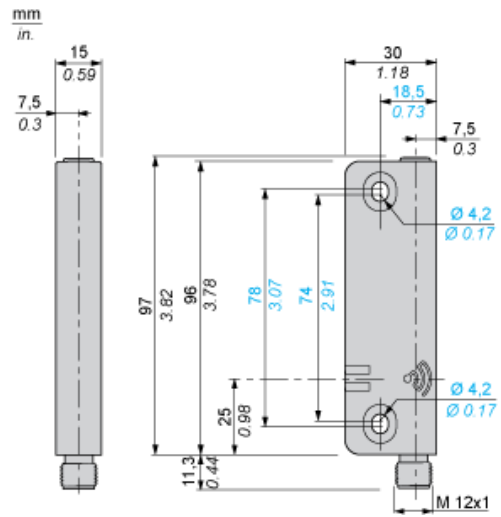

Connections

M12 Connector, 5-pin

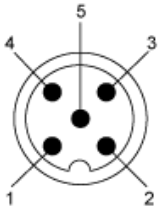

- (1) + 24 VDC
- (2) OSSD2
- (3) 0 VDC
- (4) OSSD1
- (5) NC (Not connected)

Connections

Wiring Diagram: Connection to a Safety Relay

Cat. 4 / PL=e (EN/ISO 13849-1) / SIL3 (IEC 61508) / SILCL3 IEC 62061), if combined with an appropriate Preventa XPS Safety unit PL=e / SIL3

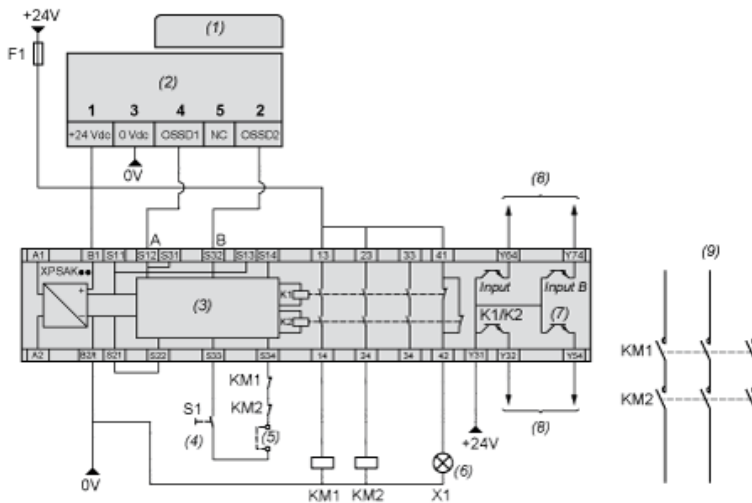

- (1) Transponder
- (2) Reader
- (3) Logic
- (4) Start
- (5) ESC: External start conditions
- (6) H1: indicator light deactivated
- (7) Fuse. Operating status of internal electronic fuse
- (8) To PLC
- (9) Power circuit

NOTE: KM1 and KM2 contactors must have force-guided contacts.

Connections

Wiring Diagram: Connection to a Safety Controller

Cat. 4 / PL=e (EN/ISO 13849-1) / SIL3 (IEC 61508) / SILCL3 IEC 62061), if combined with an appropriate Preventa XPS Safety controller PL=e / SIL3

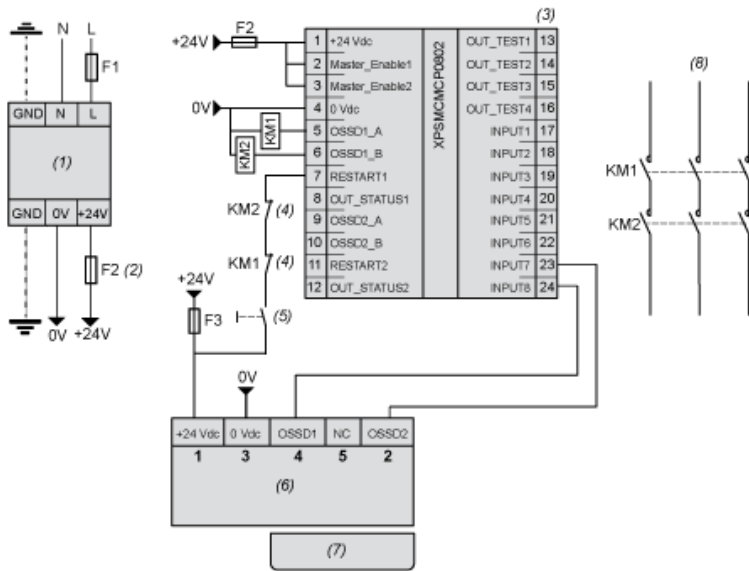

- (1) Power supply
- (2) 1 A max.
- (3) Safety controller
- (4) Feedback
- (5) Restart
- (6) Reader
- (7) Transponder
- (8) Power circuit

NOTE: KM1 and KM2 contactors must have force-guided contacts.

## Mounting and Clearance

### Face to Face Mounting (Preferred Configuration)

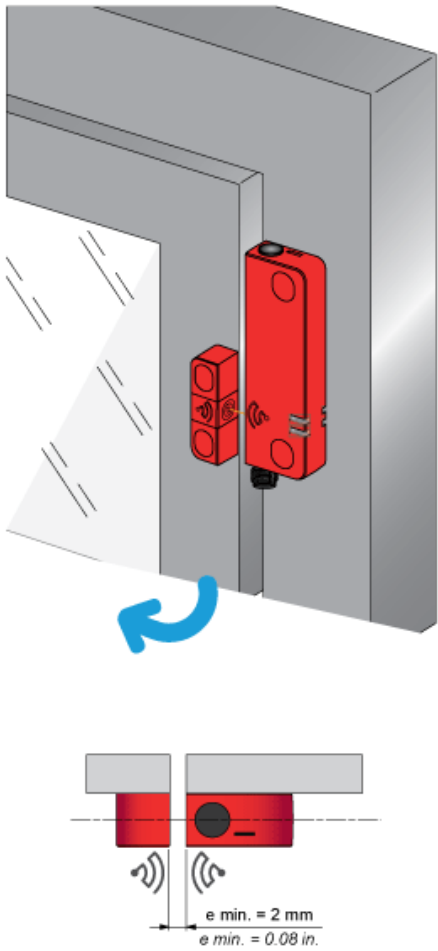
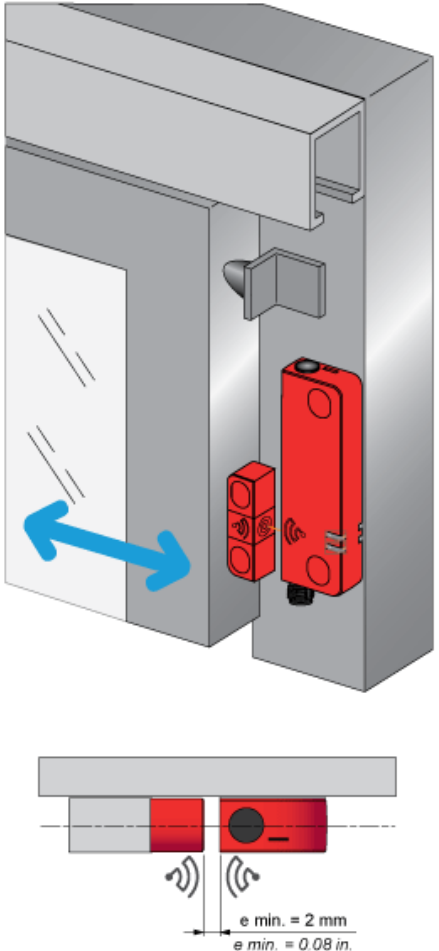
Example n°1	Example n°2
 <p><math>e \text{ min.} = 2 \text{ mm}</math> <math>e \text{ min.} = 0.08 \text{ in.}</math></p>	 <p><math>e \text{ min.} = 2 \text{ mm}</math> <math>e \text{ min.} = 0.08 \text{ in.}</math></p>
<p>e: Recommended minimum mounting distance between transponder and reader.</p>	<p>e: Recommended minimum mounting distance between transponder and reader.</p>

## Face to Face Mounting (Preferred Configuration)

Example n°3

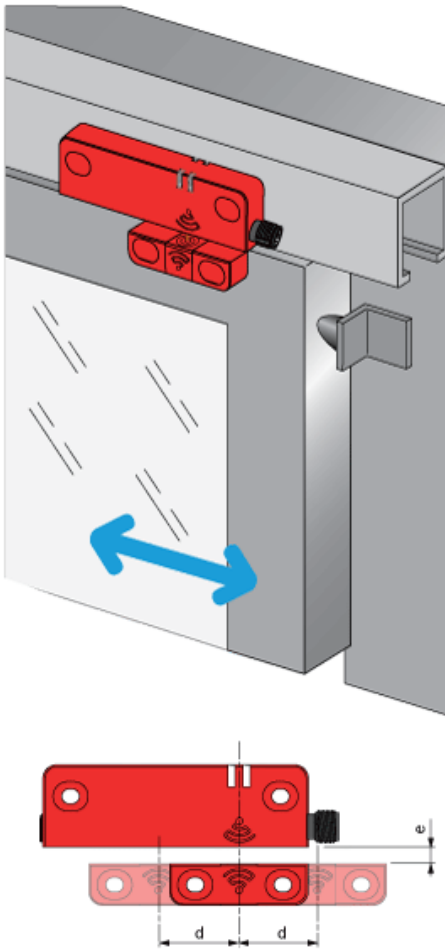

$e > 2 \text{ mm}$ . (e: recommended minimum mounting distance between transponder and reader)  
min.  
d : Detection limit

## Mounting and Clearance

---

### Side by Side Mounting

Correct Mounting Configuration

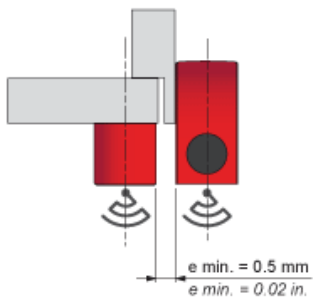
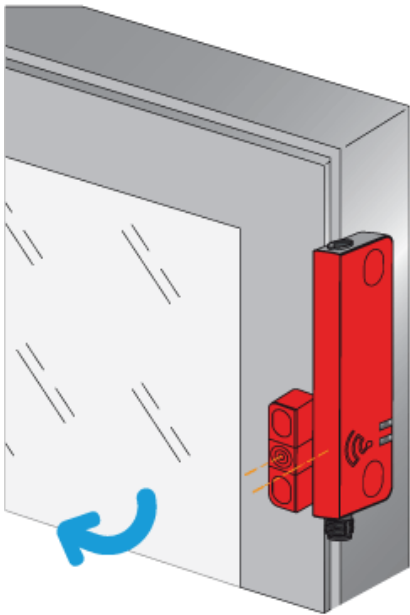

e: Recommended minimum mounting distance between transponder and reader.

## Mounting and Clearance

### Minimum Mounting Clearances between Safety Switches

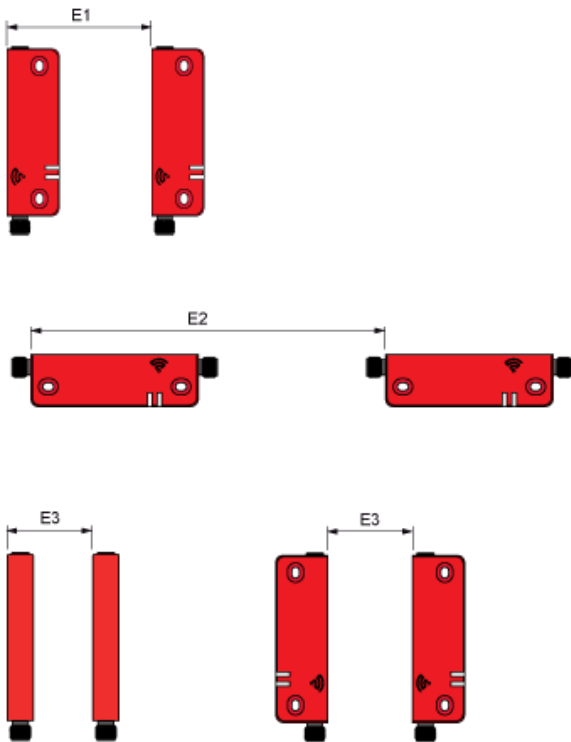

Dimensions in mm

E1 min.	E2 min.	E3 min.
45	150	65



Dimensions in in.

E1 min.	E2 min.	E3 min.
1.77	5.91	2.56

Detection Curves

Face to Face Mounting (Preferred Configuration)

Sao and Sar sensing distances along Y axis as function of Z (longitudinal misalignment for X=0)

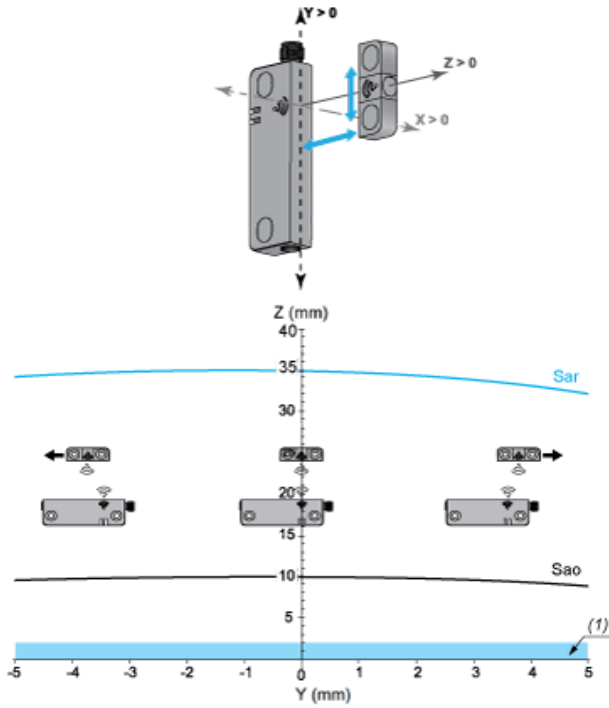

Sar: Assured release distance

Sao: Assured operating distance

(1) Recommended minimum mounting distance between transponder and reader.

Sao and Sar sensing distances along X axis as function of Z (transverse misalignment for Y=0)

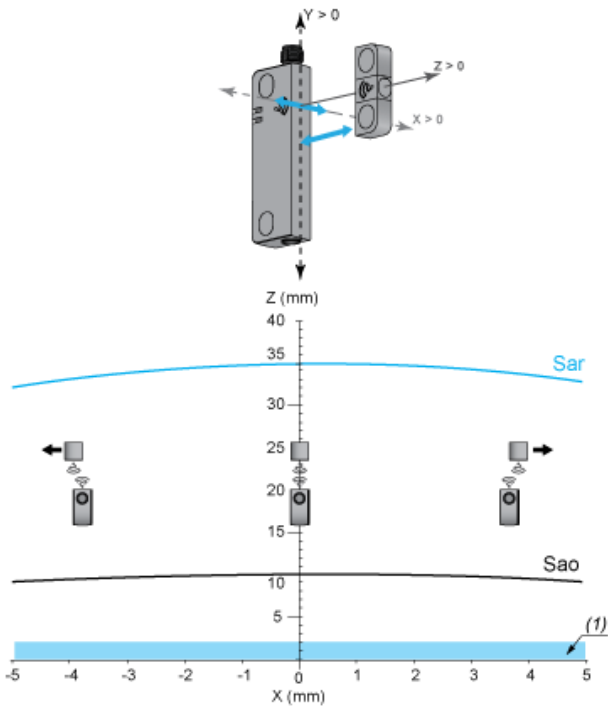

Sar: Assured release distance  
 Sao: Assured operating distance  
 (1) Recommended minimum mounting distance between transponder and reader.

## Detection Curves

### Side by Side Mounting

Sao and Sar sensing distances along Y axis as function of X (longitudinal misalignment for Z=0mm)

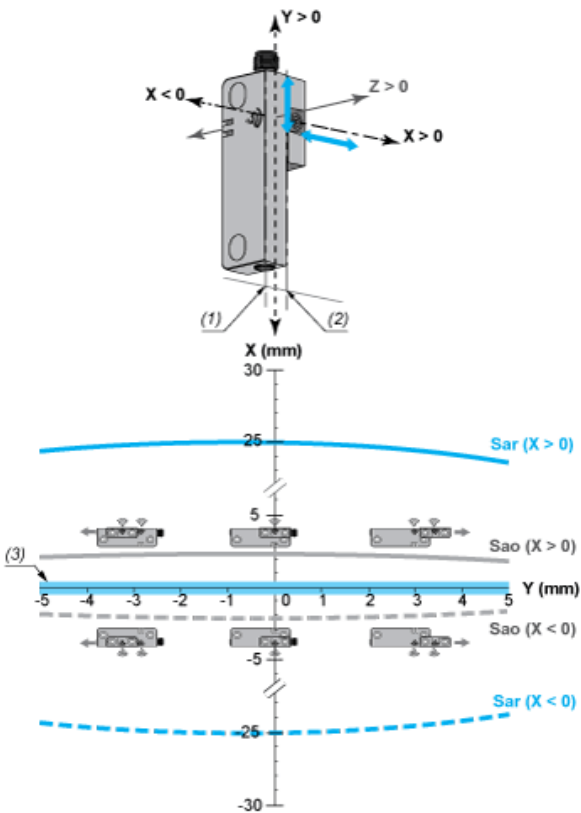

Sar: Assured release distance  
 Sao: Assured operating distance  
 (1)  $X=0$  for  $X < 0$   
 (2)  $X=0$  for  $X > 0$   
 (3) Recommended minimum mounting distance between transponder and reader.

Sao and Sar sensing distances along Z axis as function of X (transverse misalignment for Y=0mm)

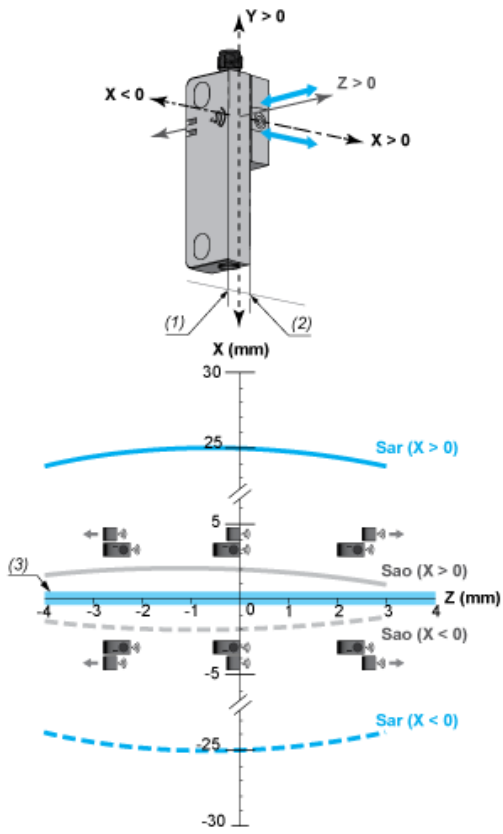

Sar: Assured release distance

Sao: Assured operating distance

(1)  $X=0$  for  $X < 0$

(2)  $X=0$  for  $X > 0$

(3) Recommended minimum mounting distance between transponder and reader.