

# MX2

## Born to drive machines

- Current vector control
- High starting torque: 200% at 0.5 Hz
- Double rating VT 120%/1 min and CT 150%/1 min
- Speed range up to 1000 Hz
- IM & PM motor control
- Torque control in open loop vector
- Positioning functionality
- Built-in application functionality (i.e. Brake control)
- User programmable as standard
- Safety embedded compliant with ISO13849-1 (double input circuit and external device monitor EDM)
- USB port for PC programming
- 24 VDC backup supply for control board
- Fieldbus communications: Modbus, DeviceNet, Profibus, Componet, Ethercat, ML-II and CanOpen
- PC configuration tool: CX-Drive
- RoHS, CE, cULus

## Ratings

- 200 V Class single-phase 0.1 to 2.2 kW
- 200 V Class three-phase 0.1 to 15.0 kW
- 400 V Class three-phase 0.4 to 15.0 kW



## System configuration

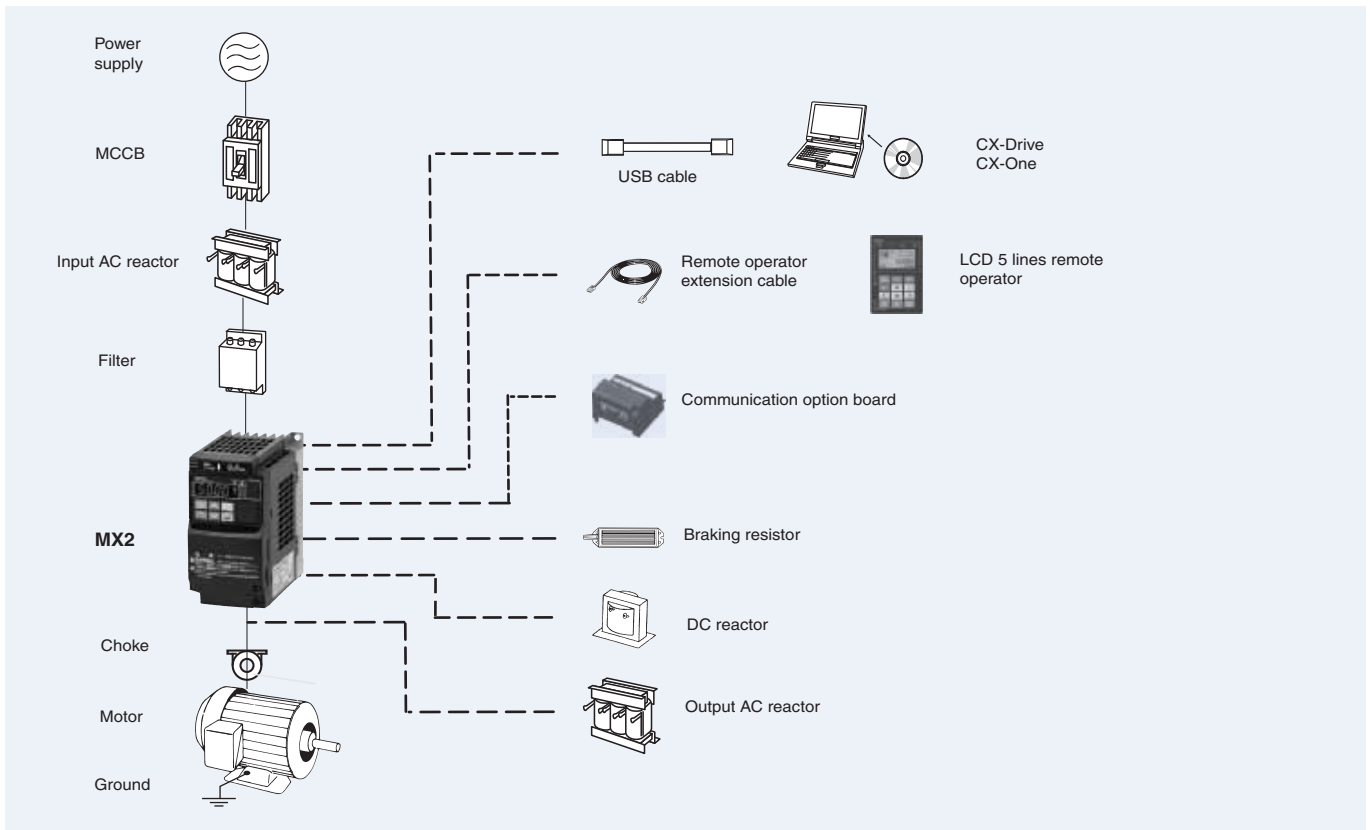

Specifications

Type designation

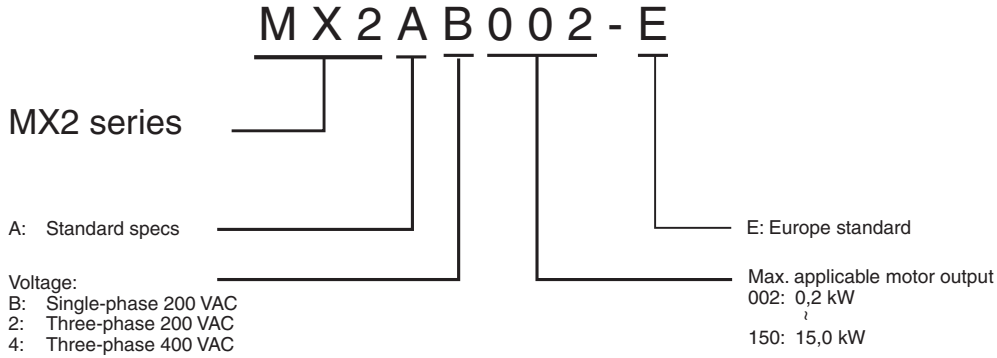

200 V class

Single-phase: MX2□		AB001	AB002	AB004	AB007 <sup>1</sup>	AB015	AB022	-	-	-	-	-	
Three-phase: MX2□		A2001	A2002	A2004	A2007	A2015	A2022	A2037	A2055	A2075	A2110	A2150	
Motor kW <sup>2</sup>	For VT setting	0.2	0.4	0.55	1.1	2.2	3.0	5.5	7.5	11	15	18.5	
	For CT setting	0.1	0.2	0.4	0.75	1.5	2.2	3.7	5.5	7.5	11	15	
Output characteristics	Inverter capacity kVA	200 VT	0.4	0.6	1.2	2.0	3.3	4.1	6.7	10.3	13.8	19.3	23.9
		200 CT	0.2	0.5	1.0	1.7	2.7	3.8	6.0	8.6	11.4	16.2	20.7
		240 VT	0.4	0.7	1.4	2.4	3.9	4.9	8.1	12.4	16.6	23.2	28.6
		240 CT	0.3	0.6	1.2	2.0	3.3	4.5	7.2	10.3	13.7	19.5	24.9
	Rated output current (A) at VT	1.2	1.9	3.5	6.0	9.6	12.0	19.6	30.0	40.0	56.0	69.0	
Rated output current (A) at CT	1.0	1.6	3.0	5.0	8.0	11.0	17.5	25.0	33.0	47.0	60.0		
Max. output voltage	Proportional to input voltage: 0..240 V												
Max. output frequency	1000 Hz <sup>3</sup>												
Power supply	Rated input voltage and frequency	Single-phase 200..240 V 50/60 Hz 3-phase 200..240 V 50/60 Hz											
	Allowable voltage fluctuation	-15%..+10%											
	Allowable frequency fluctuation	5%											
Braking torque	At short-time deceleration	100%: <50Hz 50%: <60Hz				70%: <50Hz 50%: <60Hz	Approx 20%						
	At capacitor feedback												
Cooling method		Self cooling					Forced-air-cooling						

1. Three phase model use forced-air-cooling but single phase model is self cooling.
2. Based on a standard 3-Phase standard motor.
3. Above 400 Hz with some function limitation.

400 V class

Three-phase: MX2□		A4004	A4007	A4015	A4022	A4030	A4040	A4055	A4075	A4110	A4150	
Motor kW <sup>1</sup>	For VT setting	0.75	1.5	2.2	3.0	4.0	5.5	7.5	11	15	18.5	
	For CT setting	0.4	0.75	1.5	2.2	3.0	4.0	5.5	7.5	11	15	
Output characteristics	Inverter capacity kVA	380 VT	1.3	2.6	3.5	4.5	5.7	7.3	11.5	15.1	20.4	25.0
		380 CT	1.1	2.2	3.1	3.6	4.7	6.0	9.7	11.8	15.7	20.4
		480 VT	1.7	3.4	4.4	5.7	7.3	9.2	14.5	19.1	25.7	31.5
		480 CT	1.4	2.8	3.9	4.5	5.9	7.6	12.3	14.9	19.9	25.7
	Rated output current (A) at VT	2.1	4.1	5.4	6.9	8.8	11.1	17.5	23.0	31.0	38.0	
Rated output current (A) at CT	1.8	3.4	4.8	5.5	7.2	9.2	14.8	18.0	24.0	31.0		
Max. output voltage	Proportional to input voltage: 0..480 V											
Max. output frequency	1000 Hz <sup>2</sup>											
Power supply	Rated input voltage and frequency	3-phase 380..480 V 50/60 Hz										
	Allowable voltage fluctuation	-15%..+10%										
	Allowable frequency fluctuation	5%										
Braking torque	At short-time deceleration <sup>*3</sup>	100%: <50Hz 50%: <60Hz				70%: <50Hz 50%: <60Hz						
	At capacitor feedback											
Cooling method		Self cooling				Forced-air-cooling						

1. Based on a standard 3-Phase standard motor.
2. Above 400 Hz with some function limitation.

Specifications

Common specifications

Model number MX2□	Specifications		
Control functions	<b>Control methods</b>	Phase-to-phase sinusoidal pulse with modulation PWM (Sensorless vector control, V/F)	
	<b>Output frequency range</b>	0.10..1000.00 Hz (with restrictions above 400Hz)	
	<b>Frequency precision</b>	Digital set value: ±0.01% of the max. frequency	
		Analogue set value: ±0.2% of the max. frequency (25 ±10°C)	
	<b>Resolution of frequency set value</b>	Digital set value: 0.01 Hz	
		Analogue set value: 1/1000 of maximum frequency	
	<b>Resolution of output frequency</b>	0.01Hz	
	<b>Starting torque</b>	200% / 0.5 Hz	
	<b>Overload capability</b>	Dual rating: Heavy duty (CT): 150% for 1 minute Normal Duty (VT): 120% for 1 minute	
<b>Frequency set value</b>	0 to 10 VDC (10 KΩ), 4 to 20 mA (100 Ω), RS485 Modbus, Network options		
<b>V/f Characteristics</b>	Constant/ reduced torque, free V/f		
Functionality	<b>Inputs signals</b>	FW (forward run command), RV (reverse run command), CF1~CF4 (multi-stage speed setting), JG (jog command), DB (external braking), SET (set second motor), 2CH (2-stage accel./decel. command), FRS (free run stop command), EXT (external trip), USP (startup function), CS (commercial power switchover), SFT (soft lock), AT (analog input selection), RS (reset), PTC (thermistor thermal protection), STA (start), STP (stop), F/R (forward/reverse), PID (PID disable), PIDC (PID reset), UP (remote control up function), DWN (remote control down function), UDC (remote control data clear), OPE (operator control), SF1~SF7 (multi-stage speed setting; bit operation), OLR (overload restriction), TL (torque limit enable), TRQ1 (torque limit changeover1), TRQ2 (torque limit changeover2), BOK (Braking confirmation), LAC (LAD cancellation), PCLR (position deviation clear), ADD (add frequency enable), F-TM (force terminal mode), ATR (permission of torque command input), KHC (Cumulative power clear), MI1~MI7 (general purpose inputs for EzSQ), AHD (analog command hold), CP1~CP3 (multistage-position switches), ORL (limit signal of zero-return), ORC (trigger signal of zero-return), SPD (speed/position changeover), GS1~GS2 (STO inputs, safety related signals), 485 (Starting communication signal), PRG (executing EzSQ program), HLD (retain output frequency), ROK (permission of run command), EB (rotation direction detection of B-phase), DISP (display limitation), OP (option control signal), NO (no function)	
	<b>Output signals</b>	RUN (run signal), FA1~FA5 (frequency arrival signal), OL,OL2 (overload advance notice signal), OD (PID deviation error signal), AL (alarm signal), OTQ (over/under torque threshold), UV (under-voltage), TRQ (torque limit signal), RNT (run time expired), ONT (power ON time expired), THM (thermal warning), BRK (brake release), BER (brake error), ZS (0Hz detection), DSE (speed deviation excessive), POK (positioning completion), ODC (analog voltage input disconnection), OIdc (analog current input disconnection), FBV (PID second stage output), NdC (network disconnect detection), LOG1~LOG3 (Logic output signals), WAC (capacitor life warning), WAF (cooling fan warning), FR (starting contact), OHF (heat sink overheat warning), LOC (Low load), MO1~MO3 (general outputs for EzSQ), IRDY (inverter ready), FWR (forward operation), RVR (reverse operation), MJA (major failure), WCO (window comparator O), WCOI (window comparator OI), FREF (frequency command source), REF (run command source), SETM (second motor in operation), EDM (STO (safe torque off) performance monitor), OP (option control signal), NO (no function)	
	<b>Standard functions</b>	Free-V/f, manual/automatic torque boost, output voltage gain adjustment, AVR function, reduced voltage start, motor data selection, auto-tuning, motor stabilization control, reverse running protection, simple position control, simple torque control, torque limiting, automatic carrier frequency reduction, energy saving operation, PID function, non-stop operation at instantaneous power failure, brake control, DC injection braking, dynamic braking (BRD), frequency upper and lower limiters, jump frequencies, curve accel and decel (S, U, inversed U,EL-S), 16-stage speed profile, fine adjustment of start frequency, accel and decel stop, process jogging, frequency calculation, frequency addition, 2-stage accel/decel, stop mode selection, start/end freq., analog input filter, window comparators, input terminal response time, output signal delay/hold function, rotation direction restriction, stop key selection, software lock, safe stop function, scaling function, display restriction, password function, user parameter, initialization, initial display selection, cooling fan control, warning, trip retry, frequency pull-in restart, frequency matching, overload restriction, over current restriction, DC bus voltage AVR	
	<b>Analogue inputs</b>	2 analogue inputs 0 to 10 V (10 KΩ), 4 to 20 mA (100 Ω)	
	<b>Pulse train input terminal</b>	0 to 10 V (up to 24 V), up to 32 kHz	
	<b>Accel/Decel times</b>	0.01 to 3600.0 s (line/curve selection), 2nd accel/decel setting available	
	<b>Display</b>	Status indicator LED's Run, Program, Alarm, Power, Hz, Amps Digital operator: Available to monitor 32 items: frequency reference, output current, output frequency...	
	Protection functions	<b>Motor overload protection</b>	Electronic Thermal overload relay and PTC thermistor input
		<b>Instantaneous overcurrent</b>	200% of rated current
		<b>Overload</b>	Dual rating: Heavy duty (CT): 150% for 1 minute Normal Duty (VT): 120% for 1 minute
<b>Overvoltage</b>		800 V for 400 V type and 400 V for 200 V type	
<b>Undervoltage</b>		345 V for 400 V type and 172.5 V for 200 V type	
<b>Momentary power loss</b>		Following items are selectable: Alarm, decelerates to stop, decelerates to stop with DC bus controlled, restart	
<b>Cooling fin overheat</b>		Temperature monitor and error detection	
<b>Stall prevention level</b>		Stall prevention during acceleration/deceleration and constant speed	
<b>Ground fault</b>		Detection at power-on	
<b>Power charge indication</b>	On when power is supplied to the control part		
Ambient conditions	<b>Degree of protection</b>	IP20, Varnish coating on PCB	
	<b>Ambient humidity</b>	90% RH or less (without condensation)	
	<b>Storage temperature</b>	-20°C..+65°C (short-term temperature during transportation)	
	<b>Ambient temperature</b>	-10°C to 40°C	
	<b>Installation</b>	Indoor (no corrosive gas, dust, etc.)	
	<b>Installation height</b>	Max. 1000 m	
<b>Vibration</b>	5.9 m/s <sup>2</sup> (0.6G), 10 to 55 Hz		

Dimensions

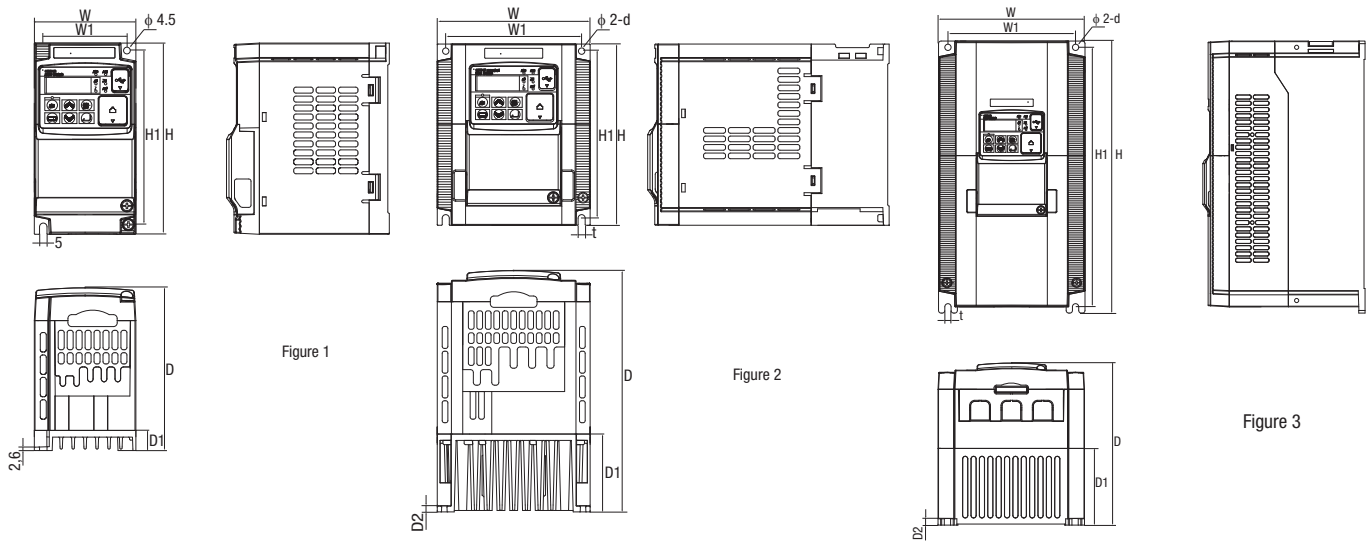

Voltage class	Inverter model	MX2	Figure	Dimensions in mm									Weight (KG)
				W	W1	H	H1	t	D	D1	D2	d	
Single-phase 200 V	AB001		1	68	56	128	118	-	109	13.5	-	-	1.0
	AB002	1	1.0										
	AB004	1	108	96	128	118	-	123	27	4.4	4.5	1.1	
	AB007	2						1.4					
	AB015	2						1.8					
AB022	2	1.8											
Three-phase 200 V	A2001		1	68	56	128	118	-	109	13.5	-	-	1.0
	A2002	1	1.0										
	A2004	1	108	96	128	118	-	113	27	4.4	4.5	1.1	
	A2007	1						1.2					
	A2015	2						1.6					
	A2022	2	1.8										
	A2037	3	2.0	140	128	128	118	5	170.5	55	4.4	4.5	3.0
	A2055	3	3.0	140	122	260	248	6	155	73.3	6	6	3.4
	A2075	3	3.4										
A2110	3	5.1											
A2150	3	7.4	180	160	296	284	7	175	97	5	7	5.1	
Three-phase 400 V	A4004	2	108	96	128	118	-	-	144	28	-	-	1.5
	A4007	2							1.6				
	A4015	2							1.8				
	A4022	2							1.9				
	A4030	2	1.9	140	128	128	118	5	171	55	4.4	4.5	2.1
	A4040	3	2.1										
	A4055	3	3.5										
	A4075	3	3.5										
	A4110	3	4.7										
A4150	3	5.2	180	160	296	284	7	175	97	5	7	5.2	

Rasmi footprint filters

Rasmi model		Dimensions					
		W	H	L	X	Y	M
1x200 V	AX-FIM1010-RE	71	45	169	156	51	M4
	AX-FIM1014-RE	111	50	169	156	91	M4
	AX-FIM1024-RE	111	50	169	156	91	M4
3x200 V	AX-FIM2010-RE	82	50	194	181	62	M4
	AX-FIM2020-RE	111	50	169	156	91	M4
	AX-FIM2030-RE	144	50	174	161	120	M4
	AX-FIM2060-RE	150	52	320	290	122	M5
	AX-FIM2080-RE	188	62	362	330	160	M5
3x400 V	AX-FIM2100-RE	220	62	415	380	192	M6
	AX-FIM3005-RE	111	45	169	156	91	M4
	AX-FIM3010-RE	114	45	169	156	91	M4
	AX-FIM3014-RE	144	50	174	161	120	M4
	AX-FIM3030-RE	150	52	306	290	122	M5
	AX-FIM3050-RE	182	62	357	330	160	M5

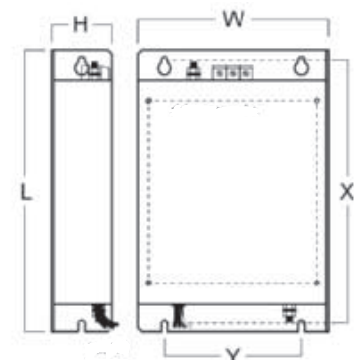

Option board

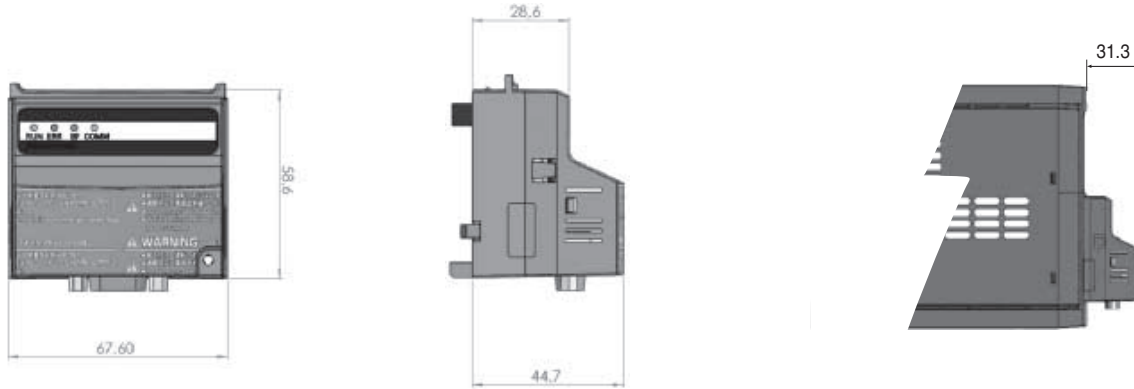

Input AC reactor

Voltage	Reference	Dimensions						Weight kg
		A	B2	C2	D	E	F	
200 V	AX-RAI02800080-DE	120	70	120	80	52	5.5	1.78
	AX-RAI00880200-DE	120	80	120	80	62	5.5	2.35
	AX-RAI00350335-DE	180	85	190	140	55	6	5.5
	AX-RAI00180670-DE	180	85	190	140	55	6	5.5
400 V	AX-RAI07700050-DE	120	70	120	80	52	5.5	1.78
	AX-RAI03500100-DE	120	80	120	80	62	5.5	2.35
	AX-RAI01300170-DE	120	80	120	80	62	5.5	2.50
	AX-RAI00740335-DE	180	85	190	140	55	6	5.5

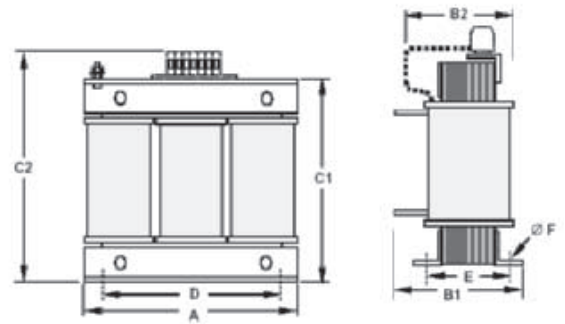

DC Reactor

Voltage	Reference	Dimensions								Weight kg	
		A	B	C	D	E	F	G	H		
200 V	AX-RC21400016-DE	84	113	96	101	66	5	7.5	2	9.5	1.22
	AX-RC10700032-DE			105							1.60
	AX-RC06750061-DE			105							1.60
	AX-RC03510093-DE			116							1.95
	AX-RC02510138-DE	108	135	124	120	82	6.5	7	-	3.20	
	AX-RC01600223-DE	120	152	136	135	94	7			9.5	5.20
	AX-RC01110309-DE	120	152	146	135	94	7	9.5	-	6.00	
	AX-RC00840437-DE			160						11.4	
	AX-RC00590614-DE			150						177	182.6
400 V	AX-RC43000020-DE	84	113	96	101	66	5	7.5	2	9.5	1.22
	AX-RC27000030-DE			105							1.60
	AX-RC14000047-DE			105							1.60
	AX-RC10100069-DE			116							1.95
	AX-RC06400116-DE	108	135	133	120	82	6.5	7	-	3.70	
	AX-RC04410167-DE	120	152	136	135	94	7			9.5	5.20
	AX-RC03350219-DE	120	152	146	135	94	7	9.5	-	6.00	
	AX-RC02330307-DE			160						11.4	
AX-RC01750430-DE	150			177						182.6	160

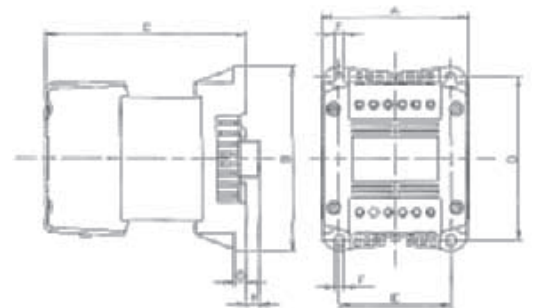

Output AC Reactor

Voltage	Reference	Dimensions						Weight kg
		A	B2	C2	D	E	F	
200 V	AX-RAO11500026-DE	120	70	120	80	52	5.5	1.78
	AX-RAO07600042-DE	120	70	120	80	52	5.5	1.78
	AX-RAO04100075-DE	120	80	120	80	62	5.5	2.35
	AX-RAO03000105-DE	120	80	120	80	62	5.5	2.35
	AX-RAO01830180-DE	180	85	190	140	55	6	5.5
	AX-RAO01150220-DE	180	85	190	140	55	6	5.5
	AX-RAO00950320-DE	180	85	205	140	55	6	6.5
	AX-RAO00630430-DE	180	95	205	140	65	6	9.1
	AX-RAO00490640-DE	180	95	205	140	65	6	9.1

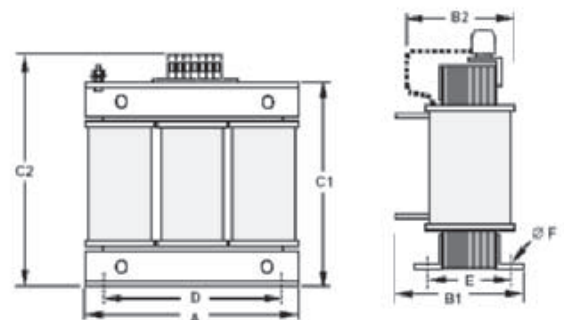

Voltage	Reference	Dimensions						Weight kg
		A	B2	C2	D	E	F	
400 V	AX-RAO16300038-DE	120	70	120	80	52	5.5	1.78
	AX-RAO11800053-DE	120	80	120	80	52	5.5	2.35
	AX-RAO07300080-DE	120	80	120	80	62	5.5	2.35
	AX-RAO04600110-DE	180	85	190	140	55	6	5.5
	AX-RAO03600160-DE	180	85	205	140	55	6	6.5
	AX-RAO02500220-DE	180	95	205	140	55	6	9.1
	AX-RAO02000320-DE	180	105	205	140	85	6	11.7

**Chokes**

Reference	D diameter	Motor kW	Dimensions						Weight kg
			L	W	H	X	Y	m	
AX-FER2102-RE	21	< 2.2	85	22	46	70	-	5	0.1
AX-FER2515-RE	25	< 15	105	25	62	90	-	5	0.2
AX-FER5045-RE	50	< 45	150	50	110	125	30	5	0.7

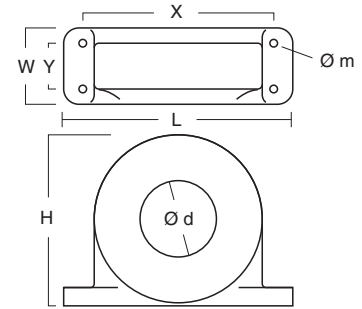

**Resistor dimensions**

AX-REM00K1200

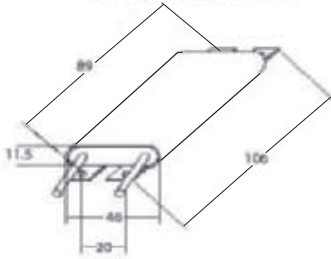

Fig 1

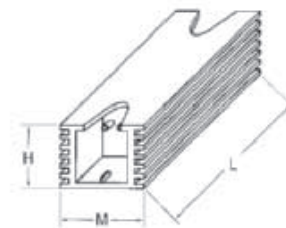

Fig 2

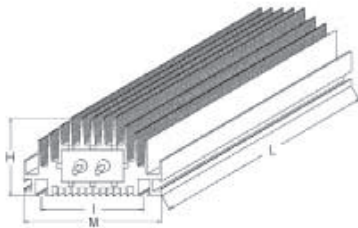

Fig 3

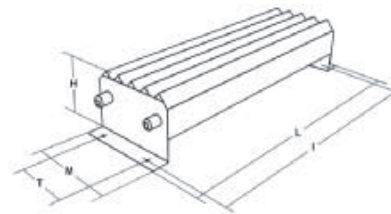
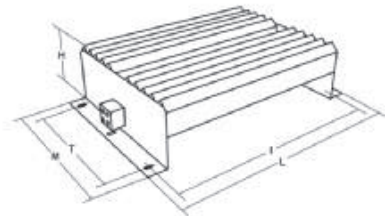

Fig 4



Type	Fig.	Dimensions					Weight kg
		L	H	M	I	T	
AX-REM00K1400-IE	1	105	27	36	94	-	0.2
AX-REM00K2070-IE							
AX-REM00K2120-IE							
AX-REM00K2200-IE							
AX-REM00K4075-IE							
AX-REM00K4035-IE							
AX-REM00K4030-IE							
AX-REM00K5120-IE							
AX-REM00K6100-IE							
AX-REM00K6035-IE							
AX-REM00K9070-IE	2	200	62	100	74	-	1.41
AX-REM00K9020-IE							
AX-REM00K9017-IE							
AX-REM01K9070-IE	3	365	73	105	350	70	4
AX-REM01K9017-IE							
AX-REM02K1070-IE	4	310	100	240	295	210	7
AX-REM02K1017-IE							
AX-REM03K5035-IE							8
AX-REM03K5010-IE							



Standard connections

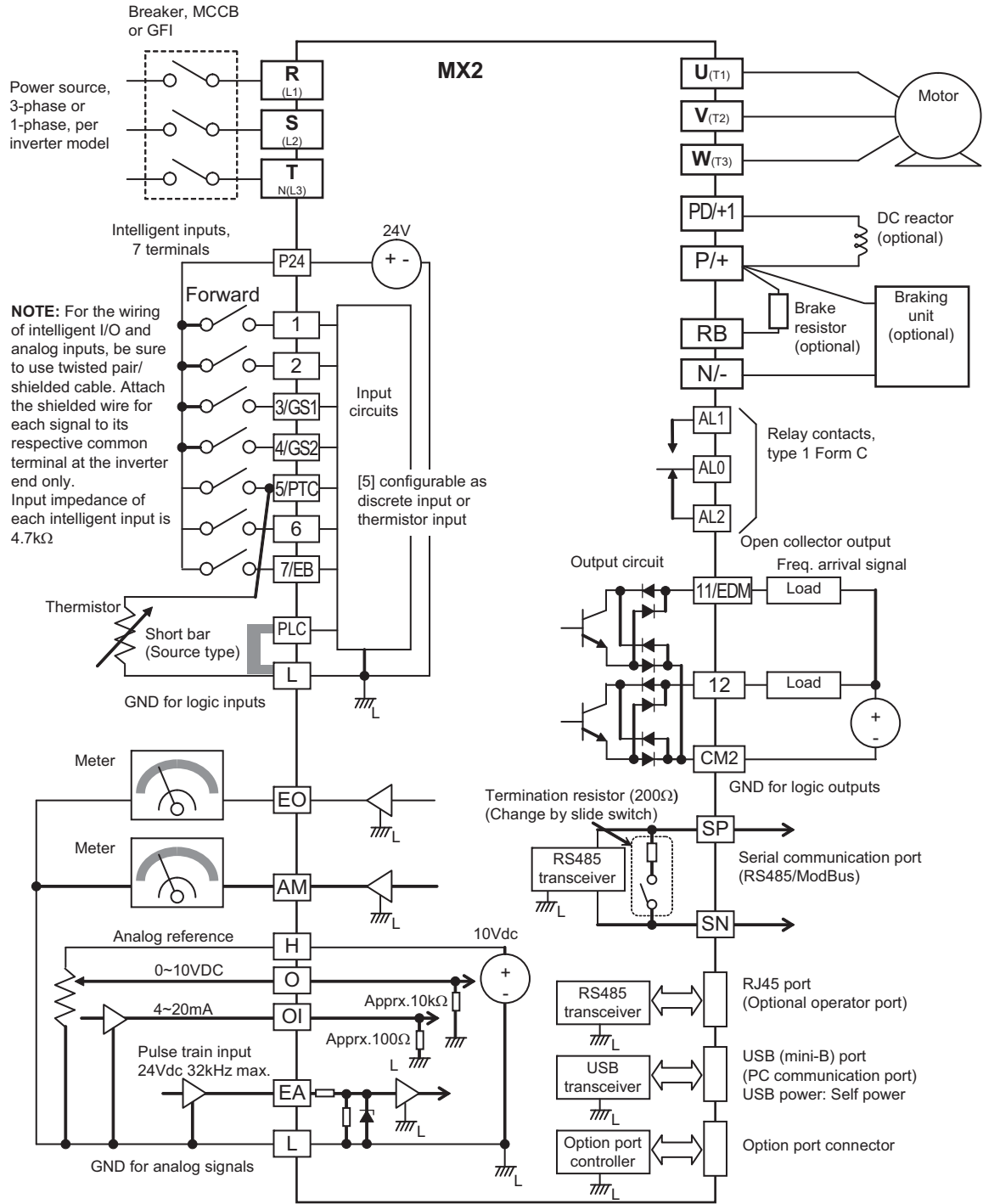

Terminal Block Specifications

Terminal	Name	Function (signal level)
R/L1, S/L2, T/L3	Main circuit power supply input	Used to connect line power to the drive. Drives with single-phase 200 V input power use only terminals R/L1 and N (T/L3), terminal S/L2 is not available for these units
U/T1, V/T2, W/T3	Inverter output	Used to connect the motor
PD/+1, P/+	External DC reactor terminal	Normally connected by the short-circuit bar. Remove the short-circuit bar between +1 and P/+2 when a DC reactor is connected.
P/+, N/-	Regenerative braking unit terminal	Connect optional regenerative braking units (If a braking torque is required)
P/+, RB	Braking resistor terminals	Connect option braking resistor (if a braking torque is required)
⊕	Grounding	For grounding (grounding should conform to the local grounding code.)

Control Circuit

Type	No.	Signal name	Function	Signal level
Digital input signals	PLC	Intelligent input common	Source type: connecting [P24] to [1]-[7] turns inputs ON Sink type: connecting [L] to [1]-[7] turns inputs ON	-
	P24	Internal 24 VDC	24 VDC, 30mA	24 VDC, 30 mA
	1	Multi-function Input selection 1	Factory setting: Forward/ Stop	27 VDC max
	2	Multi-function Input selection 2	Factory setting: Reverse/ Stop	
	3/ST1	Multi-function Input selection 3 / safe stop input 1	Factory setting: External trip	
	4/ST2	Multi-function Input selection 4 / safe stop input 2	Factory setting: Reset	
	5/PTC	Multi-function Input selection 5 / PTC thermistor input	Factory setting: Multi-step speed reference 1	
	6	Multi-function input selection 6	Factory setting: Multi-step speed reference 2	
	7/EB	Multi-function input selection 7 / Pulse train input B	Factory setting: Jog	
L	Multi-function Input selection common (in upper row)	--	--	
Pulse train	EA	Pulse train input A	Factory setting: Speed reference	32 kHz max 5 to 24 VDC
	EO	Pulse train output	LAD frequency	10 VDC 2 mA 32 kHz max
Analog input signal	H	Frequency reference power supply	10 VDC 10 mA max	
	O	Voltage frequency reference signal	0 to 10 VDC (10 kΩ)	
	OI	Current frequency reference signal	4 to 20 mA (250 Ω)	
	L	Frequency reference common (bottom row)	--	
Digital output signals	11/EDM	Discrete logic output 1 / EDM output	Factory setting: During Run	27 VDC, 50 mA max EDM based on ISO13849-1
	12	Discrete logic output 2	Factory setting: Frequency arrival type 1	
	CMD	GND logic output	--	
	AL0	Relay common contact	Factory setting: Alarm signal	R load 250 VAC 2.5 A 30 VDC 3.0 A I load 250 VAC 0.2 A 30 VDC 0.7 A
	AL1	Relay contact, normally open	Under normal operation AL1 - AL0 Closed	
AL2	Relay contact, normally closed	AL2 - AL0 Open		
Monitor Signal	AM	Analog voltage output	Factory setting: LAD frequency	0 to 10 VDC 1 mA
Comms	SP	Serial communication terminal	RS485 Modbus communication	
	SN			

Side by side mounting

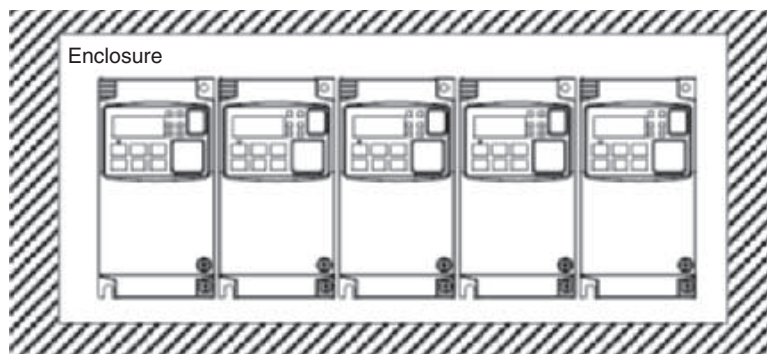

Inverter heat loss

Three-phase 200 V class

Model MX2		A2001	A2002	A2004	A2007	A2015	A2022	A2037	A2055	A2075	A2110	A2150
Inverter capacity kVA	200 VT	0.4	0.6	1.2	2.0	3.3	4.1	6.7	10.3	13.8	19.3	23.9
	200 CT	0.2	0.5	1.0	1.7	2.7	3.8	6.0	8.6	11.4	16.2	20.7
	240 VT	0.4	0.7	1.4	2.4	3.9	4.9	8.1	12.4	16.6	23.2	28.6
	240 CT	0.3	0.6	1.2	2.0	3.3	4.5	7.2	10.3	13.7	19.5	24.9
Rated current (A) VT		1.2	1.9	3.4	6.0	9.6	12.0	19.6	30.0	40.0	56.0	69.0
Rated current (A) CT		1.0	1.6	3.0	5.0	8.0	11.0	17.5	25.0	33.0	47.0	60.0
Total heat loss		12	22	30	48	79	104	154	229	313	458	625
Efficiency at rated load		89.5	90	93	94	95	95.5	96	96	96	96	96
Cooling Method		Self cooling					Forced-air-cooling					



Single-phase 200 V class

Model MX2		AB001	AB002	AB004	AB007	AB015	AB022
Inverter capacity kVA	200V VT	0.4	0.6	1.2	2.0	3.3	4.1
	200V CT	0.2	0.5	1.0	1.7	2.7	3.8
	240V VT	0.4	0.7	1.4	2.4	3.9	4.9
	240V CT	0.3	0.6	1.2	2.0	3.3	4.5
Rated current (A) VT		1.2	1.9	3.4	6.0	9.6	12.0
Rated current (A) CT		1.0	1.6	3.0	5.0	8.0	11.0
Total heat loss		12	22	30	48	79	104
Efficiency at rated load		89.5	90	93	94	95	95.5
Cooling Method		Self cooling				Forced-air-cooling	

Three-phase 400 V class

Model MX2		A4004	A4007	A4015	A4022	A4030	A4040	A4055	A4075	A4110	A4150
Inverter capacity kVA	380V VT	1.3	2.6	3.5	4.5	5.7	7.3	11.5	15.1	20.4	25.0
	380V CT	1.1	2.2	3.1	3.6	4.7	6.0	9.7	11.8	15.7	20.4
	480V VT	1.7	3.4	4.4	5.7	7.3	9.2	14.5	19.1	25.7	31.5
	480V CT	1.4	2.8	3.9	4.5	5.9	7.6	12.3	14.9	19.9	25.7
Rated current (A) VT		2.1	4.1	5.4	6.9	8.8	11.1	17.5	23.0	31.0	38.0
Rated current (A) CT		1.8	3.4	4.8	5.5	7.2	9.2	14.8	18.0	24.0	31.0
Total heat loss		35	56	96	116	125	167	229	296	411	528
Efficiency at rated load		92	93	94	95	96	96	96	96.2	96.4	96.6
Cooling Method		Self cooling				Forced-air-cooling					

Input AC Reactor

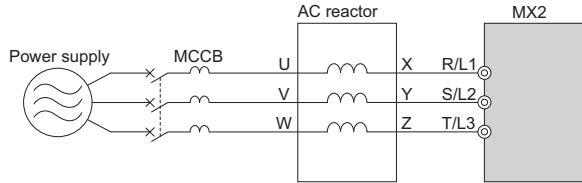

3 phase 200 V class				400 V class			
Max. applicable motor output kW	Reference	Current value A	Inductance mH	Max. applicable motor output kW	Reference	Current value A	Inductance mH
1.5	AX-RAI02800080-DE	8.0	2.8	1.5	AX-RAI07700050-DE	5.0	7.7
3.7	AX-RAI00880200-DE	20.0	0.88	4.0	AX-RAI03500100-DE	10.0	3.5
7.5	AX-RAI00350335-DE	33.5	0.35	7.5	AX-RAI01300170-DE	17.0	1.3
15	AX-RAI00180670-DE	67.0	0.18	15	AX-RAI00740335-DE	33.5	0.74

DC Reactor

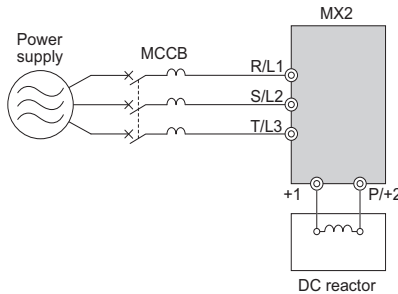

200 V class				400 V class			
Max. applicable motor output kW	Reference	Current value A	Inductance mH	Max. applicable motor output kW	Reference	Current value A	Inductance mH
0.2	AX-RC21400016-DE	1.6	21.4	0.4	AX-RC43000020-DE	2.0	43.0
0.4	AX-RC10700032-DE	3.2	10.7	0.7	AX-RC27000030-DE	3.0	27.0
0.7	AX-RC06750061-DE	6.1	6.75	1.5	AX-RC14000047-DE	4.7	14.0
1.5	AX-RC03510093-DE	9.3	3.51	2.2	AX-RC10100069-DE	6.9	10.1
2.2	AX-RC02510138-DE	13.8	2.51	3.0	AX-RC08250093-DE	9.3	8.25
3.7	AX-RC01600223-DE	22.3	1.60	4.0	AX-RC06400116-DE	11.6	6.40
5.5	AX-RC01110309-DE	30.9	1.11	5.5	AX-RC04410167-DE	16.7	4.41
7.5	AX-RC00840437-DE	43.7	0.84	7.5	AX-RC03350219-DE	21.9	3.35
11.0	AX-RC00590614-DE	61.4	0.59	11.0	AX-RC02330307-DE	30.7	2.33
15.0	AX-RC00440859-DE	85.9	0.44	15.0	AX-RC01750430-DE	43.0	1.75

Output AC Reactor

200 V class				400 V class			
Max. applicable motor output kW	Reference	Current value A	Inductance mH	Max. applicable motor output kW	Reference	Current value A	Inductance mH
0.4	AX-RAO11500026-DE	2.6	11.50	1.5	AX-RAO16300038-DE	3.8	16.30
0.75	AX-RAO07600042-DE	4.2	7.60				
1.5	AX-RAO04100075-DE	7.5	4.10				
2.2	AX-RAO03000105-DE	10.5	3.00	2.2	AX-RAO11800053-DE	5.3	11.80
3.7	AX-RAO01830160-DE	16.0	1.83	4.0	AX-RAO07300080-DE	8.0	7.30
5.5	AX-RAO01150220-DE	22.0	1.15	5.5	AX-RAO04600110-DE	11.0	4.60
7.5	AX-RAO00950320-DE	32.0	0.95	7.5	AX-RAO03600160-DE	16.0	3.60
11	AX-RAO00630430-DE	43.0	0.63	11	AX-RAO02500220-DE	22.0	2.50
15	AX-RAO00490640-DE	64.0	0.49	15	AX-RAO02000320-DE	32.0	2.00

Ordering information

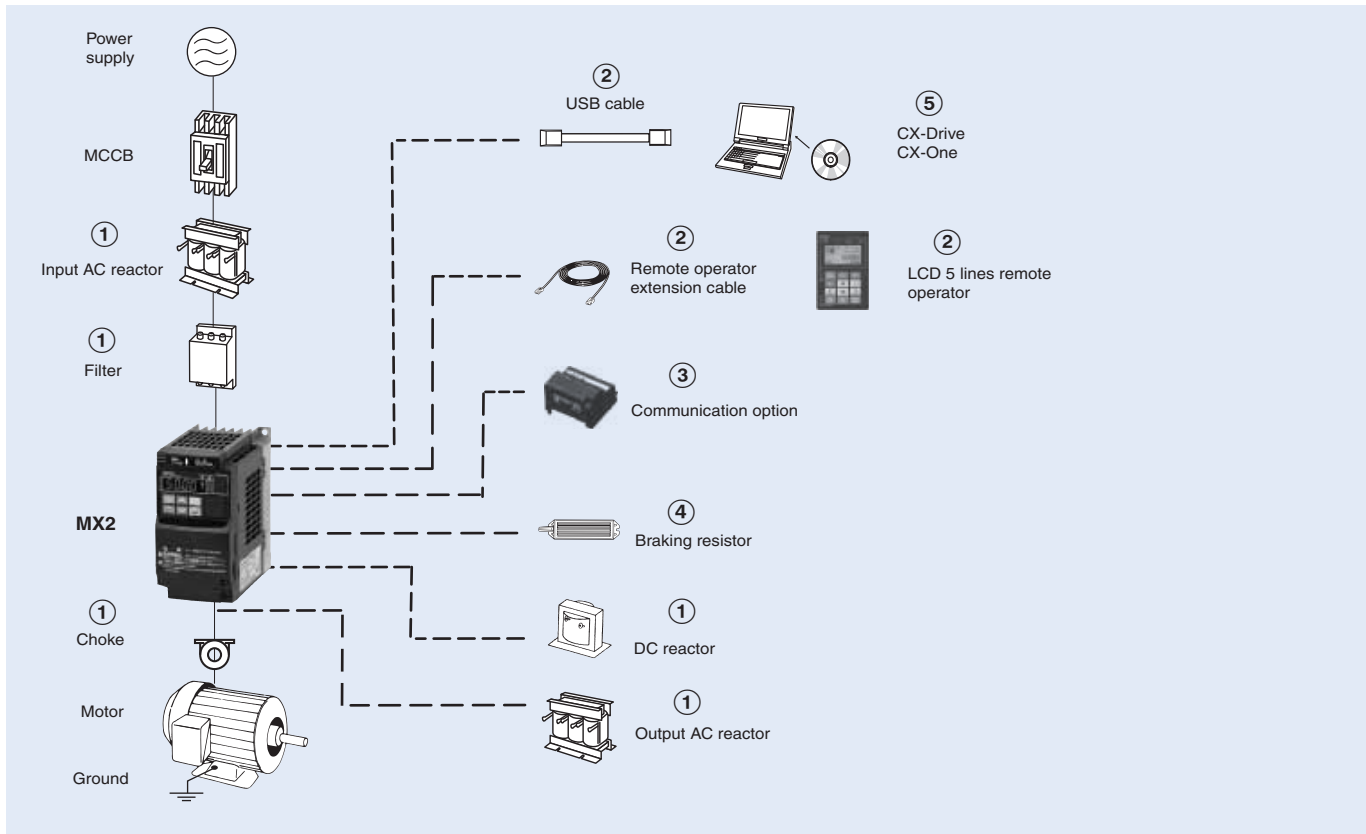

MX2

Voltage class	Specifications				Model
	Constant torque		Variable torque		Standard
	Max motor kW	Rated current A	Max motor kW	Rated current A	
Single-phase 200 V	0.1	1.0	0.2	1.2	MX2-AB001-E
	0.2	1.6	0.4	1.9	MX2-AB002-E
	0.4	3.0	0.55	3.5	MX2-AB004-E
	0.75	5.0	1.1	6.0	MX2-AB007-E
	1.5	8.0	2.2	9.6	MX2-AB015-E
	2.2	11.0	3.0	12.0	MX2-AB022-E
Three-phase 200 V	0.1	1.0	0.2	1.2	MX2-A2001-E
	0.2	1.6	0.4	1.9	MX2-A2002-E
	0.4	3.0	0.55	3.5	MX2-A2004-E
	0.75	5.0	1.1	6.0	MX2-A2007-E
	1.5	8.0	2.2	9.6	MX2-A2015-E
	2.2	11.0	3.0	12.0	MX2-A2022-E
	3.7	17.5	5.5	19.6	MX2-A2037-E
	5.5	25.0	7.5	30.0	MX2-A2055-E
	7.5	33.0	11	40.0	MX2-A2075-E
	11	47.0	15	56.0	MX2-A2110-E
Three-phase 400 V	0.4	1.8	0.75	2.1	MX2-A4004-E
	0.75	3.4	1.5	4.1	MX2-A4007-E
	1.5	4.8	2.2	5.4	MX2-A4015-E
	2.2	5.5	3.0	6.9	MX2-A4022-E
	3.0	7.2	4.0	8.8	MX2-A4030-E
	4.0	9.2	5.5	11.1	MX2-A4040-E
	5.5	14.8	7.5	17.5	MX2-A4055-E
	7.5	18.0	11	23.0	MX2-A4075-E
	11	24.0	15	31.0	MX2-A4110-E
	15	31.0	18.5	38.0	MX2-A4150-E

① Line filters

Inverter		Line filter Rasmi	
Voltage	Model MX2-□	Reference	Rated current (A)
1-Phase 200 VAC	AB001 / AB002 / AB004	AX-FIM1010-RE	10
	AB007	AX-FIM1014-RE	14
	AB015 / AB022	AX-FIM1024-RE	24
3-Phase 200 VAC	A2001 / A2002 / A2004 / A2007	AX-FIM2010-RE	10
	A2015 / A2022	AX-FIM2020-RE	20
	A2037	AX-FIM2030-RE	30
	A2055 / A2075	AX-FIM2060-RE	60
	A2110	AX-FIM2080-RE	80
3-Phase 400 VAC	A4004 / A4007	AX-FIM3005-RE	5
	A4015 / A4022 / A4030	AX-FIM3010-RE	10
	A4040	AX-FIM3014-RE	14
	A4055 / A4075	AX-FIM3030-RE	23
	A4110 / A4150	AX-FIM3050-RE	50

① Input AC reactors

Inverter		AC Reactor
Voltage	Model MX2-□	Reference
3-Phase 200 VAC	A2002 / A2004 / A2007	AX-RAI02800080-DE
	A2015 / A2022 / A2037	AX-RAI00880200-DE
	A2055 / A2075	AX-RAI00350335-DE
	A2110 / A2150	AX-RAI00180670-DE
1-Phase 200 VAC	AB002 / AB004	Under development
	AB007	
3-Phase 400 VAC	AB015 / AB022	
	A4004 / A4007 / A4015	AX-RAI07700050-DE
	A4022 / A4030 / A4040	AX-RAI03500100-DE
	A4055 / A4075	AX-RAI01300170-DE
	A4110 / A4150	AX-RAI00740335-DE

① DC reactors

200V single phase		200V 3-phase		400V 3-phase	
Inverter	DC Reactor	Inverter	DC Reactor	Inverter	DC Reactor
MX2-AB001	AX-RC10700032-DE	MX2-A2001	AX-RC21400016-DE	MX2-A4004	AX-RC43000020-DE
MX2-AB002		MX2-A2002		MX2-A4007	AX-RC27000030-DE
MX2-AB004	AX-RC06750061-DE	MX2-A2004	AX-RC10700032-DE	MX2-A4015	AX-RC14000047-DE
MX2-AB007	AX-RC03510093-DE	MX2-A2007	AX-RC06750061-DE	MX2-A4022	AX-RC10100069-DE
MX2-AB015	AX-RC02510138-DE	MX2-A2015	AX-RC03510093-DE	MX2-A4030	AX-RC08250093-DE
MX2-AB022	AX-RC01600223-DE	MX2-A2022	AX-RC02510138-DE	MX2-A4040	AX-RC06400116-DE
		MX2-A2037	AX-RC01600223-DE	MX2-A4055	AX-RC04410167-DE
		MX2-A2055	AX-RC01110309-DE	MX2-A4075	AX-RC03350219-DE
		MX2-A2075	AX-RC00840437-DE	MX2-A4011	AX-RC02330307-DE
		MX2-A2011	AX-RC00590614-DE	MX2-A4015	AX-RC01750430-DE
		MX2-A2015	AX-RC00440859-DE		-

① Chokes

Model	Diameter	Description
AX-FER2102-RE	21	For 2.2 KW motors or below
AX-FER2515-RE	25	For 15 KW motors or below
AX-FER5045-RE	50	For 45 KW motors or below

① Output AC reactor

Inverter		AC Reactor
Voltage	Model MX2-□	Reference
200 VAC	A2001 / A2002 / A2004 AB001 / AB002 / AB004	AX-RAO11500026-DE
	A2007/AB007	AX-RAO07600042-DE
	A2015 / AB015	AX-RAO04100075-DE
	A2022 / AB022	AX-RAO03000105-DE
	A2037	AX-RAO01830160-DE
	A2055	AX-RAO01150220-DE
400 VAC	A2075	AX-RAO00950320-DE
	A4004 / A4007 / A4015	AX-RAO16300038-DE
	A4022	AX-RAO11800053-DE
	A4030 / A4040	AX-RAO07300080-DE
	A4055	AX-RAO04600110-DE
	A4075	AX-RAO03600160-DE

② Accessories

Types	Model	Description	Functions
Digital operator	AX-OP05-E	LCD remote operator	5 Line LCD remote operator with copy function, cable length max. 3m.
	3G3AX-CAJOP300-EE	Remote operator cable	3 meters cable for connecting remote operator
	3G3AX-OP01	LED remote operator	LED remote operator, cable length max. 3m
	4X-KITMINI	Mounting kit for LED operator	Mounting kit for LED operator on panel
Accessories	AX-CUSBM002-E	PC configuration cable	Mini USB to USB connector cable

③ Communication option boards

Types	Model	Description	Functions
Communication options	3G3AX-MX2-PRT	Profibus option card	Used for running or stopping the inverter, setting or referencing parameters, and monitoring output frequency, output current, or similar items through Profibus communications with the host controller.
	3G3AX-MX2-DRT	DeviceNet option card	Used for running or stopping the inverter, setting or referencing parameters, and monitoring output frequency, output current, or similar items through DeviceNet communications with the host controller.
	3G3AX-MX2-ERT	Ethercat option card	Under development
	3G3AX-MX2-CRT	CompoNet option card	Used for running or stopping the inverter, setting or referencing parameters, and monitoring output frequency, output current, or similar items through CompoNet communications with the host controller.
	3G3AX-MX2-ML2	Mechatrolink II option card	Under development
	3G3AX-MX2-CORT	CanOpen option card	Under development

④ Braking unit, braking resistor unit

Voltage	Inverter			Braking resistor unit						
	Max. motor kW	Inverter MX2□		Connectable min. resistance Ω	Inverter mounted type (3%ED, 10 sec max)		Braking torque %	Inverter mounted type (10%ED, 10 sec max)		Braking torque %
		3-phase	1-phase		Type AX-	Resist Ω		Type AX-	Resist Ω	
200 V (single-/three-phase)	0.12	2001	B001	100	REM00K1400-IE	400	200	REM00K1400-IE	400	200
	0.25	2002	B002		REM00K1200-IE	200	180	REM00K1200-IE	200	180
	0.55	2004	B004				100	REM00K2070-IE	70	200
	1.1	2007	B007	50	REM00K2070-IE	70	140	REM00K4075-IE	75	130
	1.5	2015	B015				90	REM00K4035-IE	35	180
	2.2	2022	B022	35	REM00K4075-IE	75	50	REM00K6035-IE	35	100
	4.0	2040	-				75	REM00K6035-IE	20	150
	5.5	2055	-	20	REM00K4035-IE	35	75	REM01K9020-IE	20	150
	7.5	2075	-				55	REM01K9017-IE	17	110
	11	2110	-	17	REM00K6035-IE	35	40	REM02K1017-IE	17	75
15	2150	-	10	REM00K9017-IE	17	55	REM03K5010-IE	10	95	
400 V (three-phase)	0.55	4004	-	180	REM00K1400-IE	400	200	REM00K1400-IE	400	200
	1.1	4007	-		REM00K1200-IE	200	200	REM00K2200-IE	200	200
	1.5	4015	-				190	REM00K2200-IE	200	190
	2.2	4022	-	100	REM00K2120-IE	120	130	REM00K5120-IE	120	200
	3.0	4030	-				160	REM00K6100-IE	100	160
	4.0	4040	-	70	REM00K4075-IE	75	120	REM00K6100-IE	100	140
	5.5	4055	-				140	REM00K9070-IE	70	150
	7.5	4075	-				100	REM01K9070-IE	70	110
	11	4110	-	35	REM00K6100-IE	100	50	REM02K1070-IE	70	75
15	4150	-	55				REM03K5035-IE	35	110	

⑤ Computer software

Types	Model	Description	Installation
Software	CX-drive	Computer software	Configuration and monitoring software tool
	CX-One	Computer software	Configuration and monitoring software tool

ALL DIMENSIONS SHOWN ARE IN MILLIMETERS.  
To convert millimeters into inches, multiply by 0.03937. To convert grams into ounces, multiply by 0.03527.