

## Three-phase Phase-sequence Phase-loss Relay K8AB-PM

**Ideal for monitoring 3-phase power supplies for industrial facilities and equipment.**

- Monitor overvoltages, undervoltages, phase sequence, and phase loss for three-phase 3-wire or 4-wire power supplies with just one Unit.  
Switch setting for 3-phase 3-wire or 3-phase 4-wire power supply.
- Two SPDT output relays, 6 A at 250 VAC (resistive load).  
Output overvoltages and undervoltages using separate relays.
- World-wide power specifications supported by one Unit (switchable).
- Output status can be monitored using LED indicator.

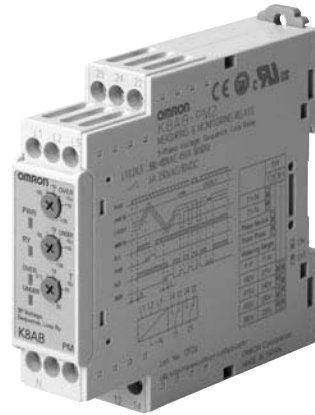

## Model Number Structure

### Model Number Legend

**K8AB-□□**

1 2 3

#### 1. Basic Model

K8AB: Measuring and Monitoring Relays

#### 2. Functions

PM: Three-phase Phase-sequence Phase-loss Relay (Simultaneous upper and lower monitoring)

#### 3. Rated Input Voltage

1: 115, 127, 133, 138, 200, 220, 230, 240 VAC

2: 220, 230, 240, 277, 380, 400, 415, 480 VAC

### Single K8AB Monitors 3-phase Power Supply with 3 or 4 Wires

Monitoring Relays can be used to monitor 3-phase power supplies with 3 or 4 wires simply by changing DIP switch settings.

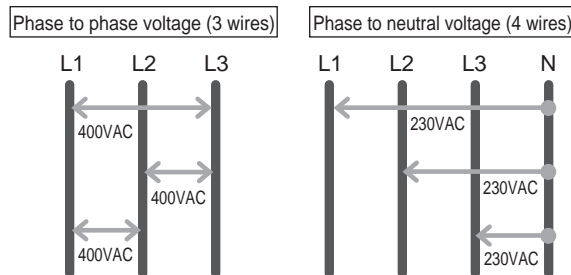

**A Single K8AB Can Monitor a 3-phase Power Supply Anywhere in the World**

**Reduces Maintenance Parts Inventory**

	SW3		ON	ON	OFF	OFF	
	SW4		ON	OFF	ON	OFF	
<b>K8AB-P□1</b>	SW2	ON	P-N	138 V	133 V	127 V	115 V
		OFF	P-P	240 V	230 V	220 V	200 V
<b>K8AB-P□2</b>	SW2	ON	P-N	277 V	240 V	230 V	220 V
		OFF	P-P	480 V	415 V	400 V	380 V

# Ordering Information

## List of Models

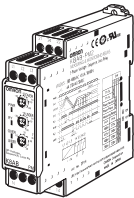
Three-phase Phase-sequence Phase-loss Relay	Rated input (See note 2.)		Model
		3-phase 3-wire mode	
3-phase 4-wire mode		115, 127, 133, 138 VAC	
3-phase 3-wire mode		380, 400, 415, 480 VAC	K8AB-PM2
3-phase 4-wire mode		220, 230, 240, 277 VAC	

**Note:** 1. Three-phase 3-wire or 4-wire and the input range are switched using a DIP switch.  
 2. The power supply is shared with the rated input voltage.

## Ratings and Specifications

### Ratings

Rated input voltage	K8AB-PM1	Three-phase, three-wire Mode: 200, 220, 230 and 240 VAC Three-phase, four-wire Mode: 115, 127, 133 and 138 VAC
	K8AB-PM2	Three-phase, three-wire Mode: 380, 400, 415 and 480 VAC Three-phase, four-wire Mode: 220, 230, 240 and 277 VAC
Input load	K8AB-PM1: 25 VA max. K8AB-PM2: 45 VA max.	
Operating value setting range (OVER, UNDER)	Overvoltage -30% to 25% of rated input voltage Undervoltage -30% to 25% of rated input voltage <b>Note:</b> The rated input voltage can be switched using the DIP switch.	
Operating value	100% operation at set value	
Reset value	5% of operating value (fixed)	
Reset method	Automatic reset	
Operating time setting range (T)	Overvoltage/undervoltage	0.1 to 30 s
	Reversed phase/phase loss	0.1 s max.
Startup lock time (LOCK)	1 s or 5 s (Switched using DIP switch.)	
Indicators	Power (PWR): Green, Relay output (RY): Yellow, OVER/UNDER: Red	
Output relays	Two SPDT relays (NC operation)	
Output relay ratings	Rated load Resistive load 6 A at 250 VAC ( $\cos\phi = 1$ ) 6 A at 30 VDC (L/R = 0 ms) Inductive load 1 A at 250 VAC ( $\cos\phi = 0.4$ ) 1 A at 30 VDC (L/R = 7 ms) Maximum contact voltage: 250 VAC Maximum contact current: 6 A AC Maximum switching capacity: 1,500 VA Minimum load: 10 mA at 5 VDC Mechanical life: 10,000,000 operations Electrical life: Make: 50,000 times, Break: 30,000 times	
Ambient operating temperature	-20 to 60°C (with no condensation or icing)	
Storage temperature	-40 to 70°C (with no condensation or icing)	
Ambient operating humidity	25% to 85% (with no condensation)	
Storage humidity	25% to 85% (with no condensation)	
Altitude	2,000 m max.	
Terminal screw tightening torque	0.49 N·m	
Terminal wiring method	Recommended wire Solid wire: 2.5 mm <sup>2</sup> Twisted wires: AWG16, AWG18 <b>Note:</b> 1. Ferrules with insulating sleeves must be used with twisted wires. 2. Two wires can be twisted together. Recommended ferrules Al 1.5-8BK (for AWG16) manufactured by Phoenix Contact Al 1-8RD (for AWG18) manufactured by Phoenix Contact Al 0.75-8GY (for AWG18) manufactured by Phoenix Contact	
Case color	Munsell 5Y8/1	
Case material	ABS resin (self-extinguishing resin) UL94-V0	
Weight	Approx. 130 g	
Mounting	Mounted to DIN Track or via M4 screws (tightening torque: 1.2 N·m)	
Dimensions	22.5 (W) × 90 (H) × 100 (D) mm	

## ■ Specifications

Input frequency range		45 to 65 Hz
Overload capacity		Continuous input: 115% of maximum input, 10 s max.: 125% of maximum input
Setting error	Operating value	Set value $\pm 10\%$ of full scale
	Operating time	
	Startup lock time	
Repeat error	Operating value	Operating value $\pm 2\%$ Error calculation: $\text{Error} = ((\text{Maximum operating value} - \text{Minimum operating value (over 10 operations)})/2) / \text{Average value} \times 100\%$
	Reset value	Overvoltage: Operating value $\times 95\% \pm 2\%$ Undervoltage: Operating value $\times 105\% \pm 2\%$ Error calculation: $\text{Error} = ((\text{Maximum reset value} - \text{Minimum reset value (over 10 resets)})/2) / \text{Average value} \times 100\%$
	Operating time	Operating time repeat error: $\pm 50$ ms Overvoltage: Measured when input suddenly changes from 70% to 120% of setting. Undervoltage: Measured when input suddenly changes from 120% to 70% of setting. The input voltage, however, must be between 70% and 125% of rating.
	Startup lock time	Startup lock time repeat error: $\pm 0.5$ s (The operating time when the operating time is set to the minimum value and the power supply suddenly changes from 0% to 100%.)
Temperature influence		Operating value Drift based on measured value at standard temperature: –20°C to standard temperature: $\pm 1,000$ ppm/°C max. Standard temperature to 60°C: $\pm 1,000$ ppm/°C max. (Humidity: 25% to 80%) Operating time Fluctuation based on measured value at standard temperature: –20°C to standard temperature: $\pm 10\%$ max. Standard temperature to 60°C: $\pm 10\%$ max. (Humidity: 25% to 80%)
Humidity influence		Operating value Based on ambient humidity of 65% 25% to 80%: $\pm 5\%$ max. Operating time Based on ambient room humidity 25% to 80%: $\pm 10\%$ max.
Influence of input frequency		At 45 to 65 Hz Operating value $\pm 5\%$ max. Operating time $\pm 10\%$ max. <b>Note:</b> The error in the operating value and operating time under standard conditions.
Applicable standards	Conforming standards	EN60255-5 and EN60255-6 Installation environment (Pollution Degree 2, Overvoltage Category III)
	EMC	EN61326
	Safety standards	UL508
Insulation resistance		20 M $\Omega$ min. Between external terminals and case Between input terminals and output 1 terminals Between input terminals and output 2 terminals Between output 1 terminals and output 2 terminals
Dielectric strength		2,000 VAC for one minute Between external terminals and case Between input terminals and output 1 terminals Between input terminals and output 2 terminals Between output 1 terminals and output 2 terminals
Noise immunity		1,500 V power supply terminal common/normal mode Square-wave noise of $\pm 1$ $\mu$ s/100 ns pulse width with 1-ns rise time
Vibration resistance		Frequency 10 to 55 Hz, 0.35-mm single amplitude, acceleration 50 m/s <sup>2</sup> 10 sweeps of 5 min each in X, Y, and Z directions
Shock resistance		100 m/s <sup>2</sup> , 3 times each in 6 directions along three axes (up/down, left/right, forward/backward)
Degree of protection		Terminal section: Finger protection

# Connections

## ■ Wiring Diagram

### Overvoltage/Undervoltage and Phase Sequence/Phase Loss Operation Diagram

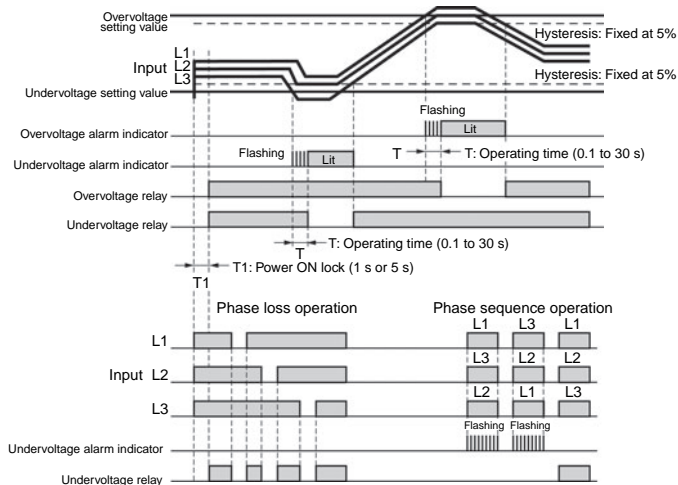

- Note:**
1. The K8AB-PM output relay is normally operative.
  2. The power ON lock prevents unnecessary alarms from being generated during the instable period when the power is first turned on. There is no relay output during timer operation.
  3. Phase loss is detected by L1, L2, and L3 voltage drops. A phase loss will exist if any of the phases drops below 60% of the rated input.
  4. L1 and L2 function both as the power supply terminals and as input terminals. If the voltage drops dramatically, then the Relay will not operate due to an undervoltage.
  5. Phase loss on the power supply or load side cannot be detected in the motor load during operation.

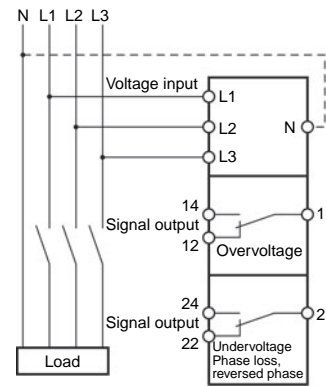

### Operation Indicators

Item	Display			Contact operation	
	Ry_LED	Over_LED	Under_LED	Over_Ry	Under_Ry
<b>Over-voltage</b>	ON	ON	OFF	OFF	ON
<b>Under-voltage</b>	ON	OFF	ON	ON	OFF
<b>Phase loss</b>	OFF	OFF (See note 1.)	ON	OFF (See note 1.)	OFF
<b>Re-versed phase</b>	ON	OFF	Flashing (See note 2.)	ON	OFF
<b>Correct phase</b>	ON	OFF	OFF	ON	ON

- Note:**
1. While phase loss is detected, Over\_Ry will also be OFF.
  2. The indicator will flash once per second after a phase loss is detected and once per 0.5 second during the detection time.

# Nomenclature

## Front

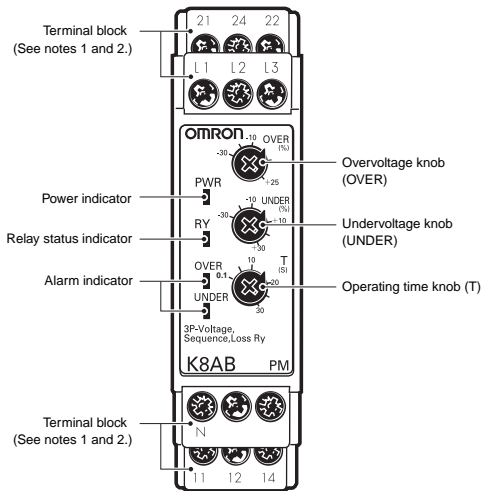

## Indicators

Item	Meaning
Power indicator (PWR: Green)	Lit when power is being supplied (see note).
Relay status indicator (RY: Yellow)	Lit when relay is operating (normally lit).
Alarm indicator	Overvoltage: Red The indicator flashes to indicate the error status after the overvoltage has exceeded the threshold value while the operating time is being clocked.
	Undervoltage: Red <ul style="list-style-type: none"> <li>Lit when there is an undervoltage or phase loss. The indicator flashes to indicate the error status after the undervoltage has exceeded the threshold value while the operating time is being clocked.</li> <li>Lit when there is a phase sequence error.</li> </ul>

**Note:** The input across L1 and L2 is used for the internal power supply. Therefore, the power indicator will not be lit if there is no input across L1 and L2.

## Setting Knobs

Item	Usage
Overvoltage knob (OVER)	Can be set between -30% and 25% of the rated input.
Undervoltage knob (UNDER)	Can be set between -30% and 25% of the rated input.
Operating time knob (T)	Used to set the operating time to 0.1 to 30 s.

**Note: 1.** Use either a solid wire of 2.5 mm<sup>2</sup> maximum or a ferrule with insulating sleeve for the terminal connection. The length of the exposed current-carrying part inserted into the terminal must be 8 mm or less to maintain dielectric strength after connection.

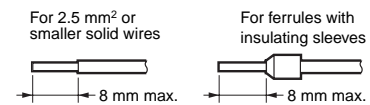

Recommended ferrules

Phoenix Contact

- AI 1,5-8BK (for AWG16)
- AI 1-8RD (for AWG18)
- AI 0,75-8GY (for AWG18)

- 2.** Tightening torque  
 Recommended: 0.49 N·m  
 Maximum: 0.54 N·m

# ■ Operation and Setting Methods

## Connections

### 1. Input

Connect to L1, L2, and L3 (for three-phase three-wire mode) or L1, L2, L3, and N (for three-phase four-wire mode), depending on the mode selected using pin 2 on the DIP switch. The Unit will not operate correctly if the DIP switch setting and the wiring do not agree. Make sure the phase sequence is wired correctly. The Unit will not operate normally if the phase sequence is incorrect.

### 2. Outputs

Terminals 11, 12, and 14 are the output terminals for overvoltage (SPDT). Terminals 21, 22, and 24 are the output terminals for undervoltage, phase loss, and reversed phase (SPDT).

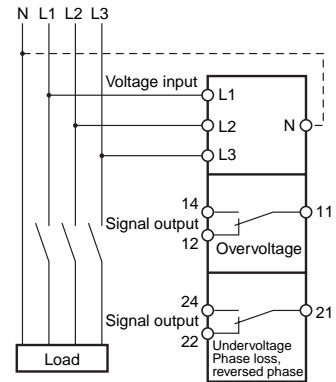

## DIP Switch Settings

The power ON lock time, number of wires, and rated voltage are set using the DIP switch located on the bottom of the Unit.

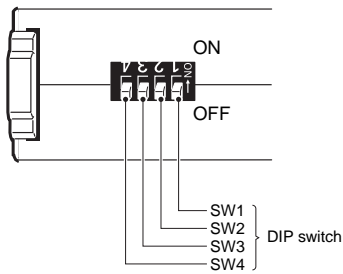

### DIP Switch Functions

#### K8AB-PM1

SWITCH		ON ● ↑				
		4	3	2	1	
Power ON lock time	5 s	---	---	---	●	
	1 s	---	---	---	○	
Number of wires	Three-phase, four-wire	---	---	●	---	
	Three-phase, three-wire	---	---	○	---	
Rated voltage	Three-phase, three-wire					
	Three-phase, four-wire					
	240 V	138 V	●	●	---	---
	230 V	133 V	●	○	---	---
	220 V	127 V	○	●	---	---
200 V	115 V	○	○	---	---	

Note: All pins are set to OFF at the factory.

#### K8AB-PM2

SWITCH		ON ● ↑				
		4	3	2	1	
Power ON lock time	5 s	---	---	---	●	
	1 s	---	---	---	○	
Number of wires	Three-phase, four-wire	---	---	●	---	
	Three-phase, three-wire	---	---	○	---	
Rated voltage	Three-phase, three-wire					
	Three-phase, four-wire					
	480 V	277 V	●	●	---	---
	415 V	240 V	●	○	---	---
	400 V	230 V	○	●	---	---
380 V	220 V	○	○	---	---	

Note: All pins are set to OFF at the factory.

## Setting Method

### 1. Overvoltage

The overvoltage knob (OVER) is used to set the overvoltage threshold.

The overvoltage can be set to between -30% and 25% of the rated input voltage.

Turn the knob while there is an input to the input terminals until the alarm indicator flashes (when the set value and the input have reached the same level.)

Use this as a guide to set the voltage.

The rated input depends on the model and DIP switch setting.

Example: K8AB-PM1 with Pin 2 Turned OFF (Three-phase, Three-wire Mode) and Pins 3 and 4 Turned OFF (Rated Voltage of 200 V)

The rated input voltage is 200 VAC and the setting range is 140 to 250 V.

### 2. Undervoltage

Undervoltage is set using the undervoltage knob (UNDER).

The undervoltage can be set to between -30% and 25% of the rated input.

Turn the knob while there is an input to the input terminals until the alarm indicator flashes (when the set value and the input have reached the same level.)

Use this as a guide to set the voltage.

The rated input depends on the model and DIP switch setting.

Example: K8AB-PM1 with Pin 2 Turned OFF (Three-phase, Three-wire Mode) and Pins 3 and 4 Turned OFF (Rated Voltage of 200 V)

The rated input voltage is 200 VAC and the setting range is 140 to 250 V.

### 3. Operating Time

The operating time is set using the operating time knob (T).

The operating time can be set to between 0.1 and 30 s.

Turn the knob while there is an input to the input terminals until the alarm indicator flashes (when the set value and the input have reached the same level.)

Use this as a guide to set the operating time.

If the input exceeds (or drops lower than) the voltage setting, the alarm indicator will start flashing for the set period and then stay lit.

## Dimensions

(Unit: mm)

### Three-phase Voltage with Phase-sequence, Phase-loss Relays

K8AB-PM1

K8AB-PM2

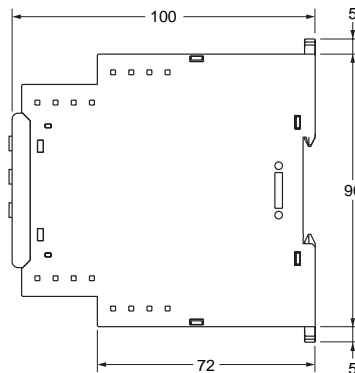
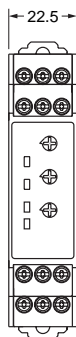
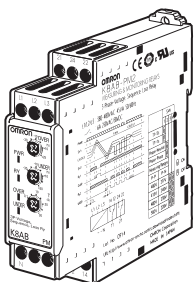

# Safety Precautions

## ■ Precautions for Safe Use

Make sure to follow the instructions below to ensure safety.

1. Do not use or keep this product in the following environments.
  - Outdoors, or places subject to direct sunlight or wearing weather.
  - Places where dust, iron powder, or corrosive gases (in particular, sulfuric or ammonia gas) exist.
  - Places subject to static electricity or inductive noise.
  - Places where water or oil come in contact with the product.
2. Make sure to install this product in the correct direction.
3. There is a remote risk of electric shock. Do not touch terminals while electricity is being supplied.
4. Make sure to thoroughly understand all instructions in the Instructions Manual before handling this product.
5. Make sure to confirm terminal makings and polarity for correct wiring.
6. Tighten terminal screws firmly using the following torque.  
Recommended tightening torque: 0.49 N·m  
Maximum tightening torque: 0.54 N·m max.
7. Operating ambient temperature and humidity for this product must be within the indicated rating when using this product.
8. There is a remote risk of explosion. Do not use this product where flammable or explosive gas exists.
9. Make sure that no weight rests on the product after installation.
10. To enable an operator to turn off this product easily, install switches or circuit breakers that conform to relevant requirements of IEC60947-1 and IEC60947-3, and label them appropriately.

## ■ Precautions for Correct Use

### For Proper Use

1. Do not use the product in the following locations.
  - Places subject to radiant heat from heat generating devices.
  - Places subject to vibrations or physical shocks.
2. Make sure to use setting values appropriate for the controlled object. Failure to do so can cause unintended operation, and may result in accident or corruption of the product.
3. Do not use thinner or similar solvent for cleaning. Use commercial alcohol.
4. When discarding, properly dispose of the product as industrial waste.
5. Only use this product within a board whose structure allows no possibility for fire to escape.

### About Installation

1. When wiring, use only recommended crimp terminals.
2. Do not block areas around the product for proper dissipation of heat. (If you do not secure space for heat dissipation, life cycle of the product will be compromised.)
3. To avoid electrical shocks, make sure that power is not supplied to the product while wiring.
4. To avoid electrical shocks, make sure that power is not supplied to the product when performing DIP switch settings.

### Noise Countermeasures

1. Do not install the product near devices generating strong high frequency waves or surges.
2. When using a noise filter, check the voltage and current and install it as close to the product as possible.
3. In order to prevent inductive noise, wire the lines connected to the product separately from power lines carrying high voltages or currents. Do not wire in parallel with or on the same cable as power lines.  
Other measures for reducing noise include running lines along separate ducts and using shield lines.

### To avoid faulty operations, malfunctions, or failure, observe the following operating instructions.

1. When turning on the power, make sure to realize rated voltage within 1 second from the time of first supply of electricity.
2. Make sure to use power supply for operations, inputs, and transformer with the appropriate capacity and rated burden.
3. Maintenance and handling of this product may only be performed by qualified personnel.
4. Distortion ratio of input wave forms must be 30% or less. Use of this product with circuits that have large distortion in wave forms may result in unwanted operations.
5. Using this product for thyristor controls or inverters will result in errors.
6. When setting the volume, adjust the control from the minimum side to the maximum side.



# Questions and Answers

**Q** **Checking Operation**

**A** **Overvoltages**  
 Gradually increase the input from 80% of the setting. The input value will equal the operating value when the input exceeds the setting and the alarm indicator starts flashing. Operation can be checked by the relay output that will start after the operating time has passed.

**Undervoltage**  
 Gradually decrease the input from 120% of the setting and check the operation using the same method as for overvoltage.

Example: For monitoring mode set to three-phase three-wire monitoring, a rated voltage of 200 V, and an operating time of 5 s.

**Note:** K8AB-PM□ output relays are normally operative.

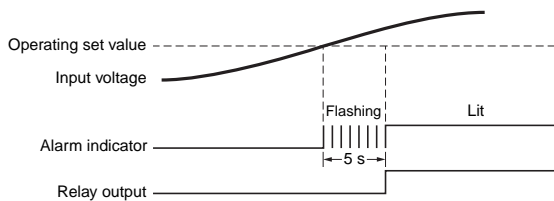

**Connection Diagram 1**

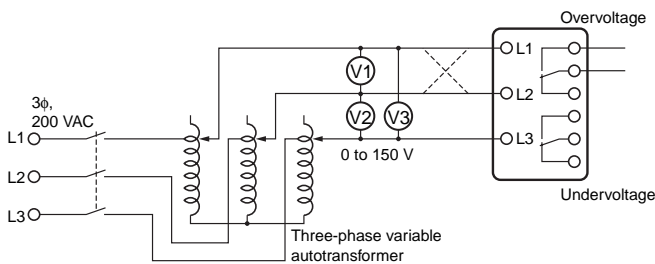

**Q** **How to Measure the Operating Time**

**A** **Overvoltage**  
 Change the input suddenly from 0% to 120% of the set value and measure the time until the Unit operates.

**Undervoltage**  
 Change the input suddenly from 120% to 0% of the set value and measure the time until the Unit operates.

**Operating Time**  
 Adjust the slide resistor so that the voltage applied to the K8AB terminals is 120% of the set value (for overvoltage detection) and 80% of the set value (for undervoltage detection) when the auxiliary relay operates, as shown in connection diagram 2. Close the switch and use the cycle counter to measure the operating time.

**Connection Diagram 2**

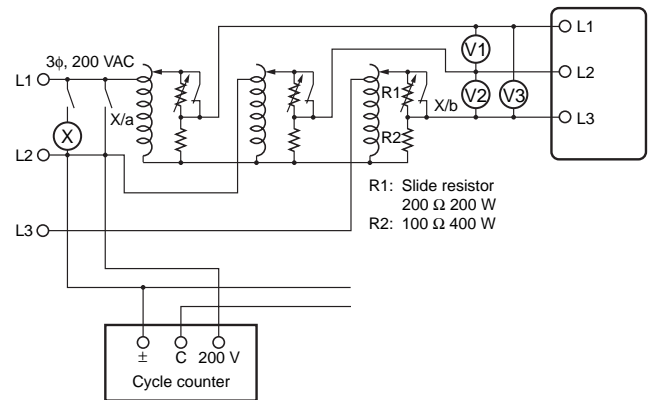

**Q** **Checking the Phase Sequence and Phase Loss Operation**

**A** **Phase Sequence**  
 Switch the wiring, as shown by the dotted lines in connection diagram 1, to reverse the phase sequence and check that the K8AB operates.

**Phase loss**  
 Create a phase loss for any input phase and check that the K8AB operates.

**Q** **Operating Adjustment Knobs**

**A** Use a screwdriver to turn the knobs. There is a stopper to prevent the knob from turning any further once it has been turned completely to the left or right. Do not force the knob past these limits.

## Questions and Answers

**Q** Load-side Phase Loss

**A** In principle, phase loss cannot be detected on the load side because the K8AB-PM□ measures three-phase voltage to determine phase loss.

**Q** Motor Load Phase Loss during Operation

**A** Motor load phase loss cannot be detected during operation. It can be used to detect phase loss at startup.

Normally, three-phase motors will continue to rotate even if one phase is open. The three-phase voltage will be induced at the motor terminals. The diagram shows voltage induction at the motor terminals when phase R has been lost with a load applied to a three-phase motor. The horizontal axis shows the motor load as a percentage of the rated load, and the vertical axis shows voltage as a percentage of the rated voltage. The lines in the graph show the voltage induced at the motor terminals for each load phase loss occurs during operation. As the graph shows, phase loss cannot be detected because the motor terminal voltage does not drop very much even if a phase is lost when the load on the motor is light. To detect motor load phase loss during operation, use the undervoltage detection function to detect the motor terminal voltages at phase loss.

Set the operating time carefully because it will affect the time from when the phase loss occurs until tripping when this function is used.

**Q** Overvoltage Detection When Only One Phase Exceeds the Overvoltage Threshold

**A** The K8AB-PM□ monitors each of the three-phase voltages. This means an overvoltage is detected if even only one phase exceeds the threshold value. The same applies to undervoltages.

### Characteristic Curve Diagram

**Note:** This characteristic curve shows the approximate values only.

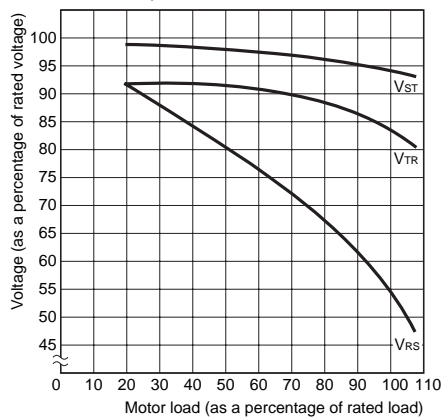

**Note:** For phase loss of phase R. V<sub>st</sub>, V<sub>tr</sub>, and V<sub>rs</sub> indicate the motor terminal voltage at phase loss.



# Warranty and Application Considerations

## Read and Understand this Catalog

Please read and understand this catalog before purchasing the products. Please consult your OMRON representative if you have any questions or comments.

## Warranty and Limitations of Liability

### WARRANTY

OMRON's exclusive warranty is that the products are free from defects in materials and workmanship for a period of one year (or other period if specified) from date of sale by OMRON.

OMRON MAKES NO WARRANTY OR REPRESENTATION, EXPRESS OR IMPLIED, REGARDING NON-INFRINGEMENT, MERCHANTABILITY, OR FITNESS FOR PARTICULAR PURPOSE OF THE PRODUCTS. ANY BUYER OR USER ACKNOWLEDGES THAT THE BUYER OR USER ALONE HAS DETERMINED THAT THE PRODUCTS WILL SUITABLY MEET THE REQUIREMENTS OF THEIR INTENDED USE. OMRON DISCLAIMS ALL OTHER WARRANTIES, EXPRESS OR IMPLIED.

### LIMITATIONS OF LIABILITY

OMRON SHALL NOT BE RESPONSIBLE FOR SPECIAL, INDIRECT, OR CONSEQUENTIAL DAMAGES, LOSS OF PROFITS, OR COMMERCIAL LOSS IN ANY WAY CONNECTED WITH THE PRODUCTS, WHETHER SUCH CLAIM IS BASED ON CONTRACT, WARRANTY, NEGLIGENCE, OR STRICT LIABILITY.

In no event shall the responsibility of OMRON for any act exceed the individual price of the product on which liability is asserted.

IN NO EVENT SHALL OMRON BE RESPONSIBLE FOR WARRANTY, REPAIR, OR OTHER CLAIMS REGARDING THE PRODUCTS UNLESS OMRON'S ANALYSIS CONFIRMS THAT THE PRODUCTS WERE PROPERLY HANDLED, STORED, INSTALLED, AND MAINTAINED AND NOT SUBJECT TO CONTAMINATION, ABUSE, MISUSE, OR INAPPROPRIATE MODIFICATION OR REPAIR.

## Application Considerations

### SUITABILITY FOR USE

OMRON shall not be responsible for conformity with any standards, codes, or regulations that apply to the combination of products in the customer's application or use of the products.

Take all necessary steps to determine the suitability of the product for the systems, machines, and equipment with which it will be used.

Know and observe all prohibitions of use applicable to this product.

NEVER USE THE PRODUCTS FOR AN APPLICATION INVOLVING SERIOUS RISK TO LIFE OR PROPERTY WITHOUT ENSURING THAT THE SYSTEM AS A WHOLE HAS BEEN DESIGNED TO ADDRESS THE RISKS, AND THAT THE OMRON PRODUCTS ARE PROPERLY RATED AND INSTALLED FOR THE INTENDED USE WITHIN THE OVERALL EQUIPMENT OR SYSTEM.

## Disclaimers

### PERFORMANCE DATA

Performance data given in this catalog is provided as a guide for the user in determining suitability and does not constitute a warranty. It may represent the result of OMRON's test conditions, and the users must correlate it to actual application requirements. Actual performance is subject to the OMRON *Warranty and Limitations of Liability*.

### CHANGE IN SPECIFICATIONS

Product specifications and accessories may be changed at any time based on improvements and other reasons. Consult with your OMRON representative at any time to confirm actual specifications of purchased product.

### DIMENSIONS AND WEIGHTS

Dimensions and weights are nominal and are not to be used for manufacturing purposes, even when tolerances are shown.

### ALL DIMENSIONS SHOWN ARE IN MILLIMETERS.

To convert millimeters into inches, multiply by 0.03937. To convert grams into ounces, multiply by 0.03527.

**OMRON Corporation** Industrial Automation Company  
Tokyo, JAPAN

Contact: [www.ia.omron.com](http://www.ia.omron.com)

#### Regional Headquarters

#### OMRON EUROPE B.V.

Wegalaan 67-69-2132 JD Hoofddorp  
The Netherlands  
Tel: (31)2356-81-300/Fax: (31)2356-81-388

#### OMRON ELECTRONICS LLC

One Commerce Drive Schaumburg,  
IL 60173-5302 U.S.A.  
Tel: (1) 847-843-7900/Fax: (1) 847-843-7787

#### OMRON ASIA PACIFIC PTE. LTD.

No. 438A Alexandra Road # 05-05/08 (Lobby 2),  
Alexandra Technopark,  
Singapore 119967  
Tel: (65) 6835-3011/Fax: (65) 6835-2711

#### OMRON (CHINA) CO., LTD.

Room 2211, Bank of China Tower,  
200 Yin Cheng Zhong Road,  
PuDong New Area, Shanghai, 200120, China  
Tel: (86) 21-5037-2222/Fax: (86) 21-5037-2200

#### Authorized Distributor:

© OMRON Corporation 2009 All Rights Reserved.  
In the interest of product improvement,  
specifications are subject to change without notice.

CSM\_1\_4\_0813

Cat. No. N146-E1-02

Printed in Japan  
0706-0.7M (0505) (C)