

Inserting the module into the hoods/housing

- The Han-Yellock® module should only be inserted into the „A“ plug-in position in the metal clamp.

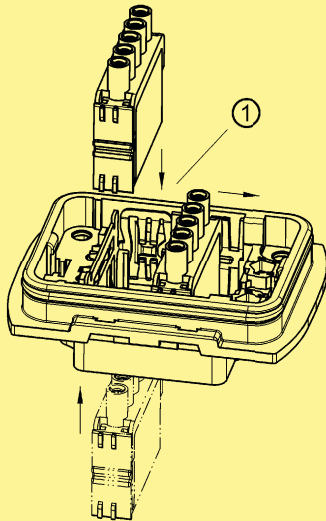

- ① plug-in position „A“
- The illustration shows the orientation of the module (see arrangement of contacts 1 ... 5).

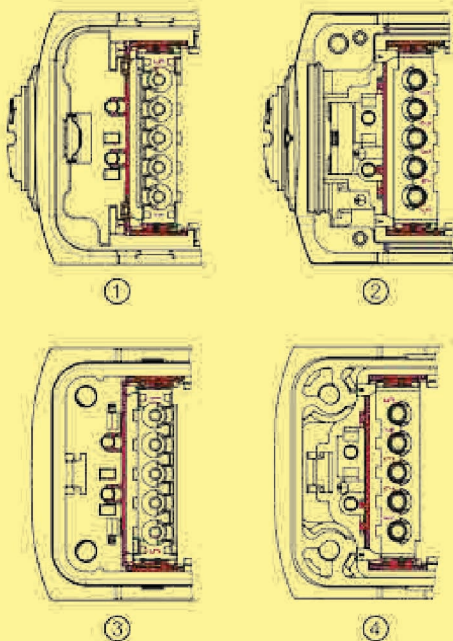

- ① Carrier hood, mating side
- ② Carrier hood, connection side
- ③ Housing, bulkhead mounting, mating side
- ④ Housing, bulkhead mounting, connection side
- A distinct click can be heard when the module snaps into position. It is then pushed along the rail to its final position. The plug-in slots must always be completely filled.

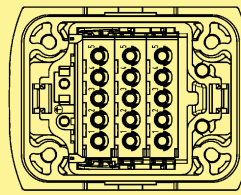

Disassembling the Han-Yellock® module

- The removal tool (part no. 11 99 000 0001) is required to take out the module.
- The following illustration shows how to insert the removal tool into the metal clamp. The tool should then be pressed down until it reaches the end stop.
- The tool is then pulled back and the module comes out of the housing.
- The removal can be made from the connection side as well as from the mating side.

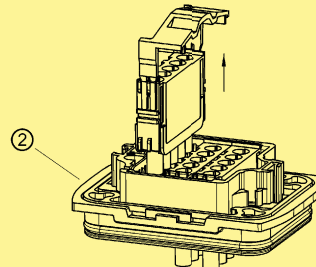
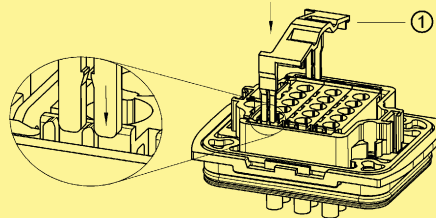

- ① removal tool
 - ② housing, bulkhead mounting
- The process is identical for both housings, bulkhead mounting, and carrier hoods.
The removal tool can be stored on the carrier hood:

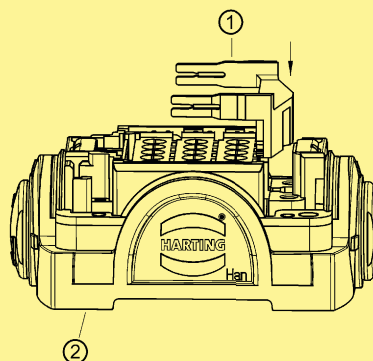

- ① removal tool
- ② carrier hood