

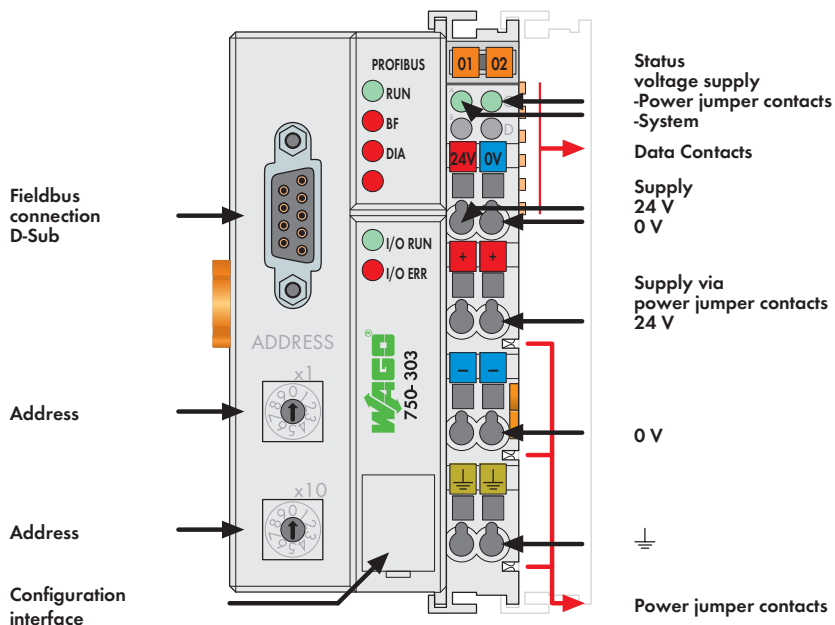

# PROFIBUS DP/FMS Fieldbus Coupler

12 Mbaud; digital and analog signals



This buscoupler connects the WAGO-I/O-SYSTEM as a slave to the PROFIBUS fieldbus.

The buscoupler automatically configures, creating a local process image which may include analog, digital or specialty modules. Analog and specialty module data is sent via words and/or bytes, digital data is sent bit by bit. PROFIBUS stores the process image in the corresponding Master control (PLC, PC or NC).

The local process image is divided into two data zones containing the data received and the data to be sent. The process data can be sent via the PROFIBUS fieldbus to the PLC, PC or NC for further processing, and received from the field via PROFIBUS.

The data of the analog modules is stored in the process image which is created automatically according to the order in which the modules are connected to the buscoupler. The bits of the digital modules are sent byte by byte and added to the analog data. If the amount of digital information exceeds 8 bits, the buscoupler automatically starts with a new byte.

**When implementing new installations with PROFIBUS DP, please consider 750-333 Fieldbus Coupler with extended functions (page 104).**

**Notice: GSD files required**

Description	Item No.	Pack. Unit
PROFIBUS DP/FMS 12 MBd	750-303	1
<b>Accessories</b>		
<b>GSD files</b>	Download: <a href="http://www.wago.com">www.wago.com</a>	
<b>Miniature WSB Quick marking system</b>		
	plain	248-501 5
	with marking	see pages 352 ... 353
<b>Standards and Approvals</b>		
	Also see "Approvals Overview" in Section 1	
Standard	EN 50170	
Certification	PNO	
Conformity marking	CE	
Shipbuilding	ABS, BV, DNV, GL, KR, LR, NKK, PRS, RINA	
UL 508	Class I, Div. 2, Grp. ABCD, T4	
ANSI/ISA 12.12.01	I M2 / II 3 GD Ex nA nL IIC T4	
EN 60079-0, -15	EN 61241-0, -1	

System Data	
No. of couplers connected to Master	96 with repeater
Max. no. of I/O points	approx. 6000 (depends on master)
Transmission medium	Cu cable acc. to EN 50170
Max. length of fieldbus segment	100 m ... 1200 m (depends on baud rate/cable)
Baud rate	9.6 Kbaud ... 12 Mbaud
Transmission time	typ. 1 ms (10 couplers; 32 digital I/Os per coupler at 12 Mbaud) max. 3.3 ms
Buscoupler connection	1 x D-Sub 9; socket