

1-Channel Relay Output Module 230 V AC, 16 A

Isolated output; 1 make contact; bistable; manual operation

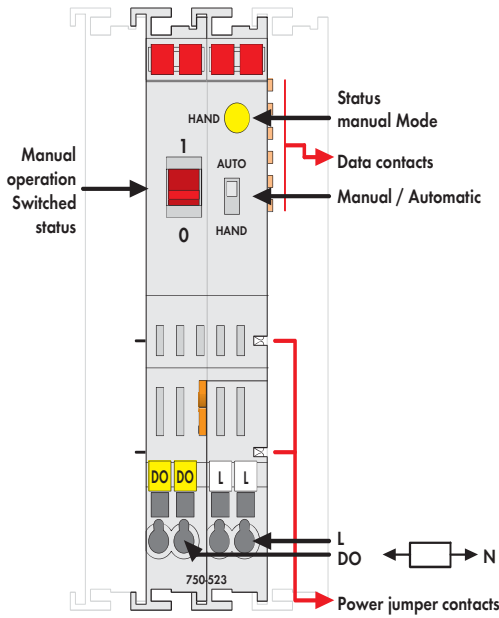

Delivered without miniature WSB markers

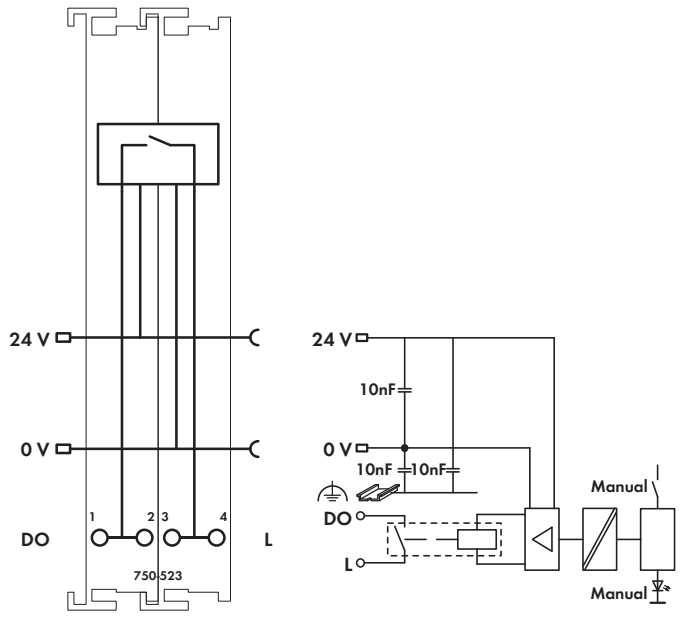

A connected actuator or load is switched via the relay output module. The 24VDC supply is derived from the power jumper contacts to trigger the relays. The switched status of the relay is shown by the manual switch (1/0). The operating mode can be set using a manual/automatic selector switch. The mode status is indicated by an LED and via status bits in the process image.
Manual: Coil triggering is interrupted. Actuation only via the red manual operating switches.
Auto: The relay is operated via the control system. Manual status changeover via manual operating switch is canceled by the control system in less than 500ms.
 The manual switch can also be used without 24V supply to switch the output ON.

The relay meets both international standards of IEC and DIN EN 61810 part 1 /VDE 0435 part 201 as well as overload and short circuit requirements of IEC and DIN EN 61036 /61037.

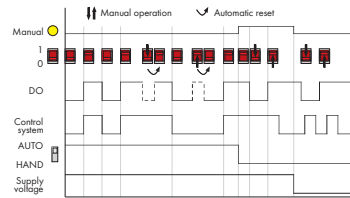

Description	Item No.	Pack. Unit
1DO 230V AC 16A Relay 1a/ Potential	750-523	1
Free		
Accessories	Item No.	Pack. Unit
Miniature WSB Quick marking system		
plain	248-501	5
with marking	see pages 352 ... 353	
Approvals Also see "Approvals Overview" in Section 1		
Conformity marking	CE	
Shipbuilding	ABS, DNV, GL, KR, PRS, RINA	
UL 508		
Technical Data		
Switchable lamp loads 100000 operations / 30000 operations		
Incandescent lamp	1.25 kW / 2.5 kW	
Fluorescent lamp, not compensated	1.2 kW / 2.5 kW	
Fluorescent lamp, parallel compensated	650 W / 70 µF / 1.3 kW / 140 µF	
Fluorescent lamp, dual circuit	2 x 1.2 kW / 2 x 2.5 kW	
Halogen lamp (AC 230 V)	1.2 kW / 2.5 kW	
Low voltage halogen lamp with transf.	500 VA / 500 VA	
Mercury arc/Sodium discharge lamp, not compensated	1 kW / 2 kW	
Mercury arc/Sodium discharge lamp, parallel compensated	1 kW / 70 µF / 2 kW / 140 µF	
Dulux lamp, not compensated	800 W / 1.6 kW	
Dulux lamp, parallel compensated	560 W / 70 µF / 1.1 kW / 140 µF	

Technical Data	
No. of outputs	1 make contact
Max. current consumption (internal)	5 mA
Max. switching voltage	440 V AC
Switching power	max. 5 kVA
Max. switching current	16 A AC
Contact material	AgSnO2
Mechanical life	10 ⁶
Current consumption max. (field side)	80 mAs (peak current)
Isolation	1.5 kV eff. (field/system)*; * 2.5 kV rated surge voltage; Overvoltage category III
Bit width	2 bits in (Manual status, -); 2 bits out (DO, -)
Wire connection	CAGE CLAMP®
Cross sections	0.08 mm ² ... 2.5 mm ² / AWG 28 ... 14
Stripped lengths	8 ... 9 mm / 0.33 in
Width	24 mm
Weight	105 g
EMC: CE - immunity to interference	acc. to EN 50082-2 (1996)
EMC: CE - emission of interference	acc. to EN 50081-1 (1993)
EMC: marine applications	
- immunity to interference	acc. to Germanischer Lloyd (2003)
EMC: marine applications	
- emission of interference	acc. to Germanischer Lloyd (2003)

1 2-Channel Analog Input Module 0-30 V

244 Differential measurement input

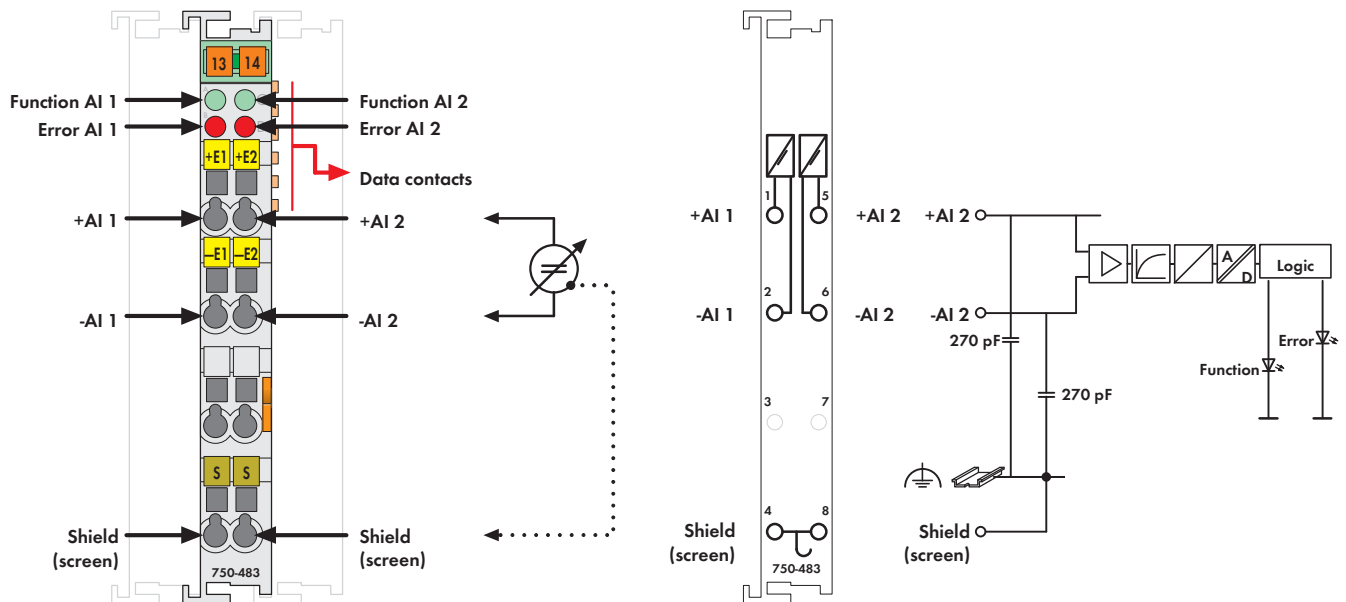

Fig. 750 Series/Technical data see page 24/Delivered without miniature WSB markers
750/753 Series marking see pages 10 ... 11 / 12 ... 13



The 2-channel analog input module processes differential signals of a standard magnitude 0–30VDC.

The input signal of each channel is electrically isolated and is transmitted with a resolution of 14 bits.

System voltage is used for voltage supply.

The shield (screen) is directly connected to the DIN rail.

- Measured-value acquisition: time synchronous (both inputs)
- Measuring range overflow/underflow: status byte and LED
- Method of conversion: SAR (Successive Approximation Register)
- Operating mode: continuously sampling (preset)
- Protection: RC circuit

Description	Item No.	Pack. Unit
2AI 0-30V DC Diff. Measur. Inp.	750-483	1
2AI 0-30V DC Diff. Measur. Inp. (without connector)	753-483	1
Accessories		
 753 Series Connectors	753-110	25
Coding elements	753-150	100
Miniature WSB Quick marking system		
 plain	248-501	5
with marking	see pages 352 ... 353	
Approvals		
Also see "Approvals Overview" in Section 1		
Conformity marking	CE	
Shipbuilding	ABS, BV, DNV, GL, KR, LR*, NKK*, PRS*, RINA* *753 Series, pending	
UL 508	Class I, Div. 2, Grp. ABCD, T4	
ANSI/ISA 12.12.01	I M2 / II 3 GD Ex nA IIC T4	
EN 60079-0, -15	EN 61241-0, -1	

Technical Data	
Number of inputs	2, electrically isolated from each other
Power supply	via system voltage DC/DC
Current consumption typ. (internal)	80 mA
Signal voltage	0 - 30V
Internal resistance	1 MΩ
Input filter	low pass first order, $f_c = 5$ kHz
Resolution of the A/D converter	14 bits
Monotonicity without missing codes	yes
Resolution of measured value	14 bits
Value of a LSB (least significant bit)	1.8 mV
Measuring error (25°C)	$\leq \pm 0.05$ % of the full scale value
Temperature coefficient	$< \pm 0.01$ % / K of the full scale value
Measuring error	≤ 0.4 % over whole temperature scale ≤ 0.1 % of upper range value (non-linearity)
Crosstalk attenuation	≥ 80 dB
Sampling time of repetition	1 ms
Sampling delay (module)	1 ms
Sampling delay (channel/channel)	≤ 1 μs
Sampling duration	≤ 5 μs
Admissible continuous overload	60 V
Dielectric strength	500 V DC channel/channel or channel/system
Bit width	2 x 16 bits data 2 x 8 bits control/status (optional)
Wire connection	CAGE CLAMP®
Cross sections	0.08 mm² ... 2.5 mm² / AWG 28 ... 14
Stripped lengths, 750/753 Series	8 ... 9 mm / 0.33 in; 9 ... 10 mm / 0.37 in
Width	12 mm
Weight	55 g
EMC: CE - immunity to interference	acc. to EN 61000-6-2 (2005)
EMC: CE - emission of interference	acc. to EN 61000-6-4 (2007)
EMC: marine app. - immunity to interference	acc. to Germanischer Lloyd (2003)
EMC: marine app. - emission of interference	acc. to Germanischer Lloyd (2003)