

LON® Data Exchange Coupler (Peer to Peer)

78 kbps; digital and analog signals

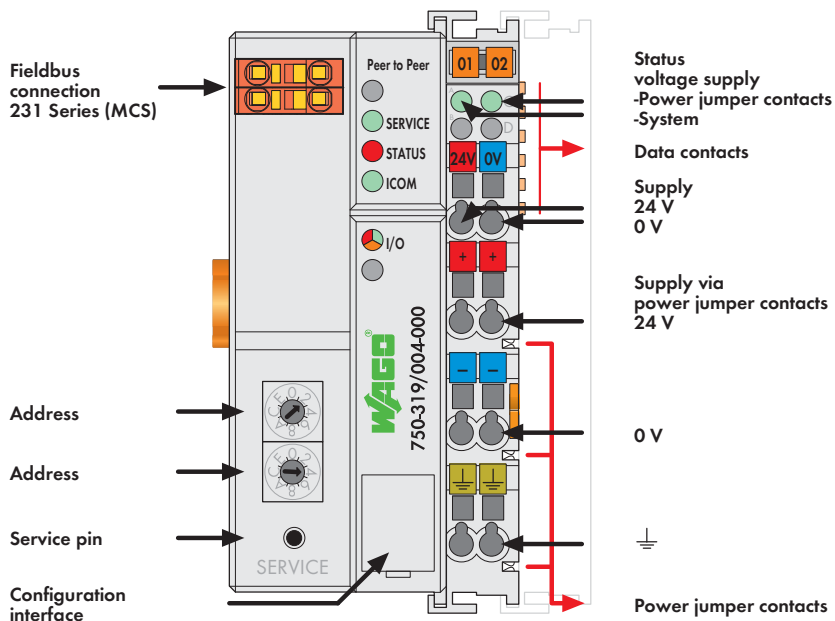

The data exchange coupler transfers the input process image data to the output process image of the coupled partner. The data exchange coupler is a variant of the LON® fieldbus coupler.

Applications:

- **Peer to Peer**
one master and one slave
- **Broadcast**
one master and several slaves

The coupler, together with I/O modules, is a fieldbus node which is connected to other nodes by means of a twisted wire pair. The coupler can also be integrated into existing LON® networks if appropriate node addresses are available.

The coupler automatically creates the process image using the types and widths of data of the connected I/O modules. The input process image is transferred to the output process image of the partner or partners.

The monitoring system switches digital outputs off or stores the last analog value if the connection to the coupled partner is interrupted longer than 1 second.

LON® is a registered trademark of Echelon Corporation.

Description	Item No.	Pack. Unit
Peer to Peer Coupler	750-319/004-000	1
Accessories		
Miniature WSB Quick marking system		
 plain	248-501	5
with marking	see pages 352 ... 353	
Approvals		
Also see "Approvals Overview" in Section 1		
Conformity marking	CE	
UL 508		
ANSI/ISA 12.12.01	Class I, Div. 2, Grp. ABCD, T4	
IEC 60079-0, -15	BR-Ex nA II T4	
EN 60079-0, -15	I M2 / II 3 GD Ex nA nL IIC T4	
EN 61241-0, -1		

System Data	
No. of couplers connected to Master	64 without repeater, 127 with repeater
Transmission medium	Twisted pair - FTT
Max. length of fieldbus segment	500 m (free topology) 2700 m (bus-topology)
Topology	in accordance with LON specification
Baud rate	78 kbps
Buscoupler connection	2-pole male connector, 231 Series (MCS), female connector (231-302) (included)

16-Channel Digital Input Module 24 V DC

Ribbon cable, high-side switching

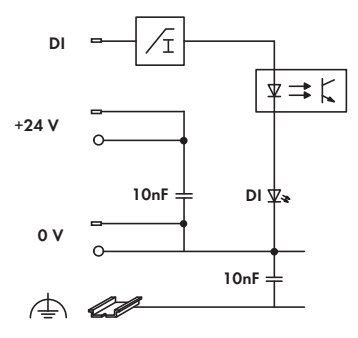
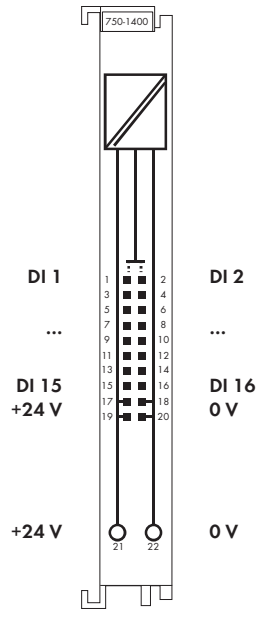
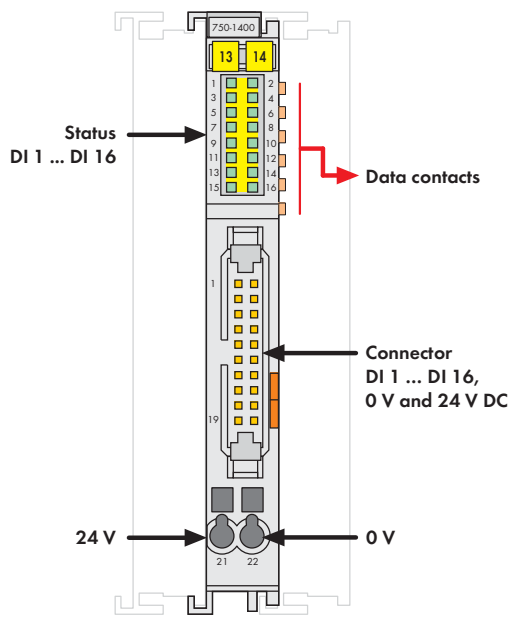

Delivered without miniature WSB markers

The digital input module provides 16 channels at a width of just 12mm (0.47in). It receives binary control signals from digital field devices (e.g., sensors, encoders, switches or proximity switches). The 750-1400 connects to electronic modules via 20-pole ribbon cable. The 24V power is fed to the electronic modules via two CAGE CLAMP® terminals. Each input channel has a noise-rejection RC filter with a 3.0ms time constant. A green LED indicates the switched status of each channel. An optocoupler provides electrical isolation between the bus and the field side.

1.3

Description	Item No.	Pack. Unit
16DI 24V DC 3.0ms, ribbon cable	750-1400	1
Accessories		
Miniature WSB Quick marking system		
 plain	248-501	5
with marking	see pages 352 ... 353	
Cable and interface modules	see section 10	
Approvals		
Also see "Approvals Overview" in Section 1		
Conformity marking	CE	
Shipbuilding	ABS, DNV, GL, KR	
UL 508		

Technical Data	
Number of inputs	16
Current consumption (internal)	25 mA
Voltage supply	24 V DC (-25 % ... +30 %)
Signal voltage (0)	-3 V ... +5 V DC
Signal voltage (1)	15 V ... 30 V DC
Input filter	3.0 ms
Input current (typ.)	+0.6 mA (at -3 V ... +5 V DC) +2.2 mA ... +2.5 mA (at 15 V ... +32 V)
Isolation	500 V system/field
Wire connection	20-pole male connector / CAGE CLAMP®
Cross sections CAGE CLAMP®	0.08 mm² ... 2.5 mm² / AWG 28 ... 14
Stripped lengths	8 ... 9 mm / 0.33 in
Dimensions (mm) W x H x L	12 x 73 x 100
Weight	Height from upper-edge of DIN 35 rail 42.6 g