

CIMR-L7Z

Varispeed L7

Made to drive lifts

- One model to control AC and PM motors.
- Silent operation with no current de-rating.
- Safety Cat.3 Stop. Cat.0 (EN 954-1 & EN81-1)
- Motor auto-tuning at standstill and at run.
- Three control methods: close loop current vector control, sensorless current vector control, V/F control.
- Direct control of motor brake and contactors
- Dedicated lift sequence built-in
- Lift units.
- Emergency operation by UPS or battery
- 2nd motor setting
- Short floor operation
- Door opening signal
- Electrical motor information and encoder information saved on inverter and encoder
- Embedded OMRON PLC functionality with PLC option card
- Fieldbus options: DeviceNet, CANOpen, PROFIBUS
- PC configuration tool: CX-drive.
- CE, UL, and cUL marking

Ratings

- 200 V Class three-phase 3.7 to 55 kW
- 400 V Class three-phase 4.0 to 55 kW



System configuration example

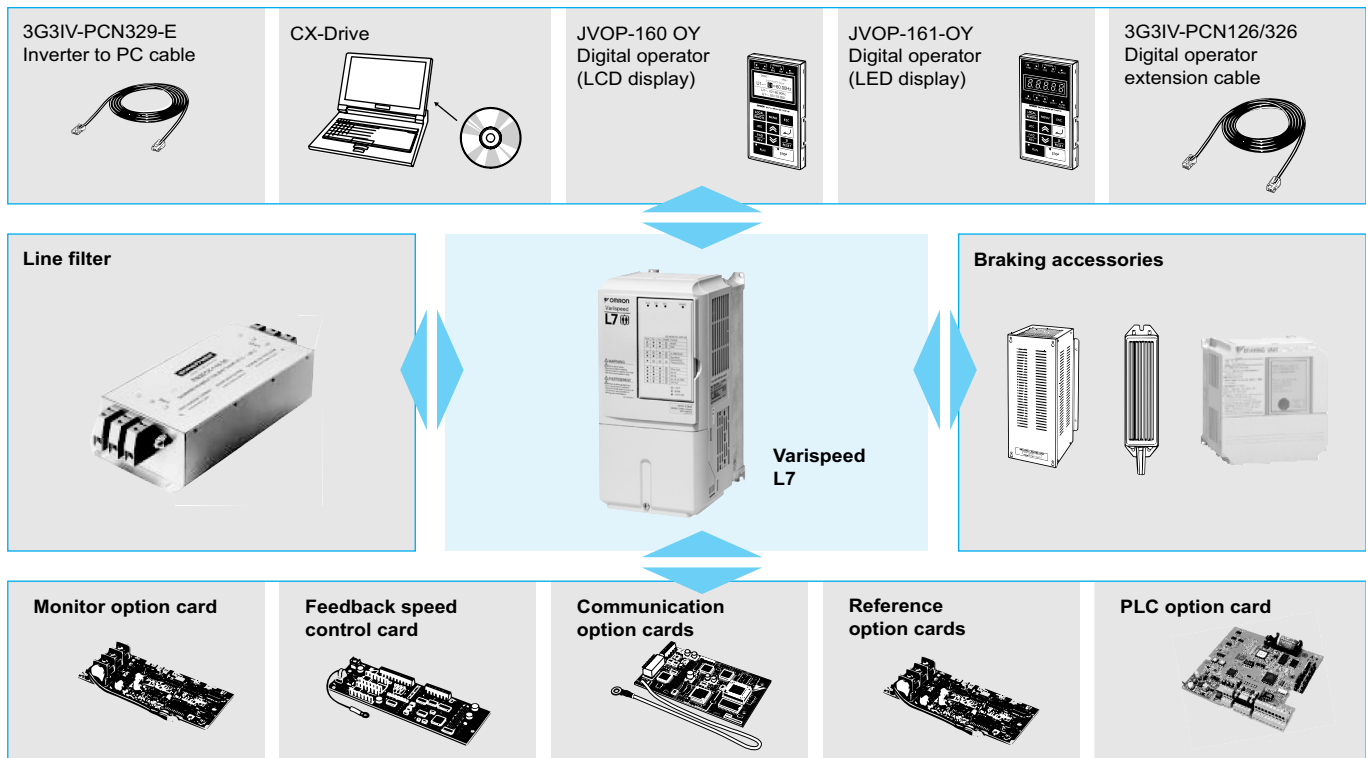

Specifications

Type designation

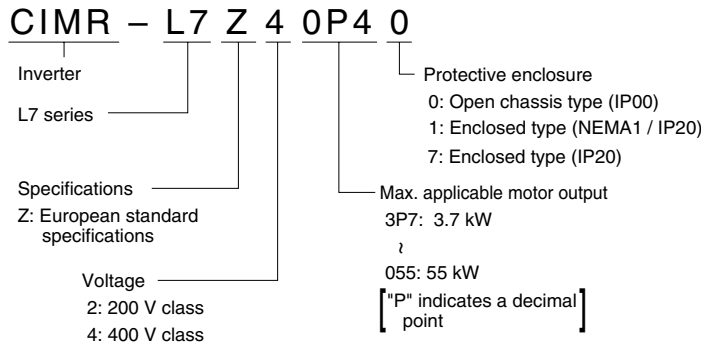

200 V class

Model CIMR-L7ZZ□		23P7	25P5	27P5	2011	2015	2018	2022	2030	2037	2045	2055	
Max. applicable motor output ¹ kW		3.7	5.5	7.5	11	15	18.5	22	30	37	45	55	
Output characteristics	Inverter capacity kVA	7	10	14	20	27	33	40	54	67	76	93	
	Rated current A	17.5	25	33	49	64	80	96	130	160	183	224	
	Max. voltage	3-phase; 200, 208, 220, 230, or 240 VAC (proportional to input voltage)											
	Max. output frequency	Up to 120 Hz available by programming											
Power supply	Rated input voltage and frequency	3-phase, 200/208/220/230/240 VAC, 50/60 Hz											
	Rated input current A	21	25	40	52	68	96	115	156	176	220	269	
	Allowable voltage fluctuation	+ 10%, - 15%											
	Allowable frequency fluctuation	±5%											
Harmonic wave prevention	DC reactor	Optional						Built In					
	12-pulse input	Not possible						Possible					

1. The maximum applicable motor output is given for a standard 4-pole Yaskawa motor. When selecting the actual motor and inverter, be sure that the inverter's rated current is applicable for the motor's rated current.
2. A transformer with dual star-delta secondary is required on the power supply for 12-pulse rectification.

400 V class

Model CIMR-L7ZZ□		44P0	45P5	47P5	4011	4015	4018	4022	4030	4037	4045	4055	
Max. applicable motor output ¹ kW		4.0	5.5	7.5	11	15	18.5	22	30	37	45	55	
Output characteristics	Inverter capacity kVA	9	12	15	22	28	34	40	54	67	80	106	
	Rated current A	11	14	18	27	34	41	48	65	80	96	128	
	Max. voltage	3-phase; 380, 400, 415, 440, 460, or 480 VAC (proportional to input voltage.)											
	Max. output frequency	120 Hz max.											
Power supply	Rated input voltage and frequency	3-phase, 380, 400, 415, 440, 460 or 480 VAC, 50/60 Hz											
	Rated input current A	13.2	17	22	32	41	49	58	78	96	115	154	
	Allowable voltage fluctuation	+ 10%, -15%											
	Allowable frequency fluctuation	±5%											
Harmonic wave prevention	DC reactor	Optional						Built In					
	12-pulse input	Not possible						Possible					

1. The maximum applicable motor output is given for a standard 4-pole Yaskawa motor. When selecting the actual motor and inverter, be sure that the inverter's rated current is applicable for the motor's rated current.
2. A transformer with dual star-delta secondary is required on the power supply for 12-pulse rectification.

Enclosures

200 V class	Model CIMR-L7Z□	20P4	20P7	21P5	22P2	23P7	25P5	27P5	2011	2015	2018	2022	2030	2037	2045	2055
		Enclosed type (IEC IP20)	Available as standard													
	Open Chassis type (IEC IP00)	Available by removing the upper and lower cover of enclosed type														
400 V class	Model CIMR-F7Z□	40P4	40P7	41P5	42P2	43P7	45P5	47P5	4011	4015	4018	4022	4030	4037	4045	4055
		Enclosed type (IEC IP20)	Available as standard													
	Open Chassis type (IEC IP00)	Available by removing the upper and lower cover of enclosed type														

Common specifications

Model number CIMR-L7Z□		Specification
Control characteristics	Control method asynchronous	Sine wave PWM closed loop vector control, open loop vector control, V/f control
	Control method synchronous	Sine wave PWM closed loop vector control using endat and hiperface
	Carrier frequency	8 kHz higher carrier frequency possible with current derating.
	Speed control range	1:40 (V/f control) 1:100 (open loop vector control) 1:1000 (closed loop vector control)
	Speed control accuracy	± 3% (V/f control) ± 0.2% (open loop vector control) ± 0.02% (closed loop vector control) (25 °C ± 10 °C)
	Speed control response	5 Hz (control without PG) 30 Hz (control with PG)
	Torque limits	Provided (4 quadrant steps can be changed by constant settings.) (Vector control)
	Torque accuracy	± 5%
	Frequency range	0.01 to 120 Hz
	Frequency accuracy (temperature characteristics)	Digital references: ± 0.01% (-10 °C to +40 °C)
		Analog references: ± 0.1% (25 °C ± 10 °C)
	Frequency setting resolution	Digital references: 0.01 Hz
		Analog references: 0.025/50 Hz (11 bits plus sign)
	Output frequency resolution	0.01 Hz
	Overload capacity and maximum current	150% of rated output current for 30 sec.
Frequency setting signal	0 to +10V	
Accel/decel time	0.01 to 600.00 s (4 selectable combinations of independent acceleration and deceleration time settings)	
Main control functions	Overtorque/undertorque detection, torque limits, 8-speed control (maximum), 4 acceleration and deceleration times, S-curve acceleration/deceleration, auto-tuning (rotational or stationary), dwell function, cooling fan ON/OFF control, slip compensation, torque compensation, auto-restart after fault, DC braking for starting and stopping, a fault reset and parameter copy function, special lift functions and sequences, short floor, hardware baseblock	
Protective functions	Motor protection	Protection by electronic thermal overload relay.
	Instantaneous overcurrent protection	Stops at approx. 200% of rated output current.
	Fuse blown protection	Stops for fuse blown.
	Overload protection	OL2 fault at 150% of rated output current for 30 sec
	Overvoltage protection	200 class inverter: stops when main-circuit DC voltage is above 410 V. 400 class inverter: stops when main-circuit DC voltage is above 820 V.
	Undervoltage protection	200 class inverter: stops when main-circuit DC voltage is below 190 V. 400 class inverter: stops when main-circuit DC voltage is below 380 V.
	Cooling fin overheating	Protection by thermistor.
	Stall prevention	Stall prevention during acceleration, deceleration and running independently.
	Grounding protection	Protection by electronic circuits.
Charge indicator	Illuminates when the main circuit DC voltage is approx. 10 VDC or more.	
Protective structure		Enclosed wall-mounted type (IP20): all models Enclosed wall-mounted type (NEMA 1): 18.5 kW or less (same for 200 V and 400 V class inverters) Open chassis type (IP00): 22 kW or more (same for 200 V and 400 V class inverters)
Environment	Ambient operating temperature	- 10 °C to 45 °C
	Ambient operating humidity	95% max. (with no condensation)
	Storage temperature	- 20 °C to + 60 °C (short-term temperature during transportation)
	Application site	Indoor (no corrosive gas, dust, etc.)
	Altitude	1000 m max.
Vibration	10 to 20 Hz, 9.8 m/s ² max.; 20 to 50 Hz, 2 m/s ² max	

Dimensions

Enclosed type (IEC IP20)

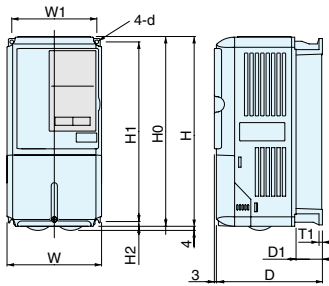

Fig 1

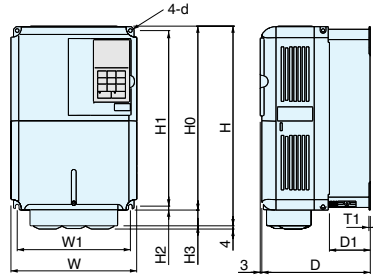

Fig 2

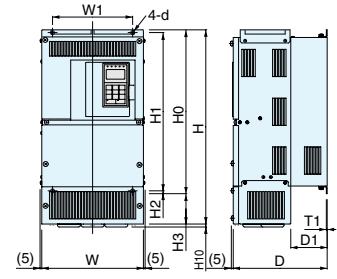

Fig 3

Voltage	Max. applicable motor output kW	Inverter CIMR-L7Z□	Fig	Dimensions in mm											Approx. weight kg	Cooling method
				W	H	D	W1	H0	H1	H2	H3	D1	T1	d		
200 V class (3-phase)	3.7	23P7 7	1	140	280	177	126	280	266	7	---	59	5	M5	4	Fan cooled
	5.5	25P5 7														
	7.5	27P5 7	2	200	300	197	186	300	285	8	0	65.5	2.3	M6	6	
	11	2011 7														
	15	2015 7														
	18.5	2018 7	3	240	350	207	216	350	335	7.5	0	78	11			
	22	2022 7														
	30	2030 1 ¹	3	254	464	258	195	400	385	7.5	30	100	3.2	M10	24	
	37	2037 1 ¹														
	45	2045 1 ¹														
55	2055 1 ¹															
400 V class (3-phase)	4.0	44P0 7	1	140	280	177	126	280	266	7	---	59	5	M5	4	Fan cooled
	5.5	45P5 7														
	7.5	47P5 7	2	200	300	197	186	300	285	8	---	65.5	2.3	M6	6	
	11	4011 7														
	15	4015 7														
	18.5	4018 7	3	240	350	207	216	350	335	7.5	64	100	10			
	22	4022 7														
	30	4030 7	3	275	535	258	220	450	435	7.5	64	100	2.3	M6	24	
	37	4037 7														
	45	4045 7														
55	4055 7															
			325	715	283	260	550	535	7.5	79	105	40				

1. F7Z2030 to 2055 meets IP20 / NEMA1

Filters

Footprint filters

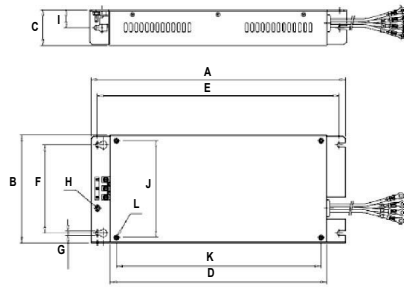

Model		Dimensions											
		A	B	C	D	E	F	G	H	I	J	K	L
200 V	3G3RV-PFI2035-SE	330	141	46	281	313	115	5.5	M5	23	126	266	M5
	3G3RV-PFI2060-SE	355	206	60	302	336	175	6.5	M6	30	186	285	M6
	3G3RV-PFI2100-SE	408	236	80	355	390	205	6.5	M6	40	216	335	M6
400 V	3G3RV-PFI3010SE	330	141	46	281	313	115	5.5	M5	23	126	266	M5
	3G3RV-PFI3018-SE	330	141	46	281	313	115	5.5	M5	23	126	266	M5
	3G3RV-PFI3021-SE	355	206	50	302	336	175	6.5	M4	25	186	285	M5
	3G3RV-PFI3035-SE	355	206	50	302	336	175	6.5	M5	25	186	285	M6
	3G3RV-PFI3060-SE	408	236	65	355	390	205	6.5	M6	32.5	216	335	M6

Bookform filters

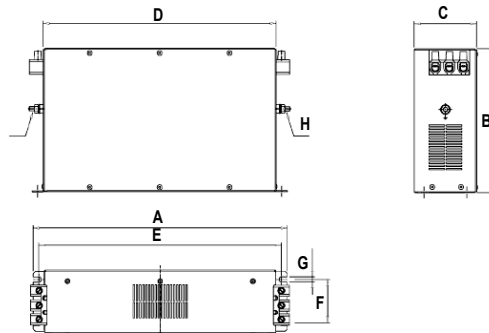

Model		Dimensions							
		A	B	C	D	E	F	G	H
200 V	3G3RV-PFI2130-SE	366	180	90	280	310	65	6.5	M10
	3G3RV-PFI2160-SE	541	170	120	350	380	102	6.5	M10
	3G3RV-PFI2200-SE	610	240	130	480	518	90	8.2	M10
400 V	3G3RV-PFI3070-SE	331	185	80	300	329	55	6.5	M6
	3G3RV-PFI3100-SE	326	150	90	240	270	65	6.5	M10
	3G3RV-PFI3130-SE	370	180	90	280	310	65	6.5	M10

Bottom filters

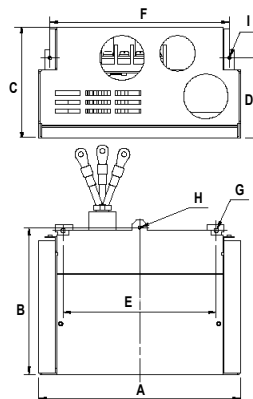

Model		Dimensions								
		A	B	C	D	E	F	G	H	I
400 V	3G3RV-PFI3018B-SE	116	84.4	107.4	-	86	-	4.5	M4	M4
	3G3RV-PFI3035B-SE	170	152.5	109	79	112	144	4.5	M4	M4
	3G3RV-PFI3060B-SE	200	145	109	79	152	178	4.5	M4	M4

Braking resistor unit

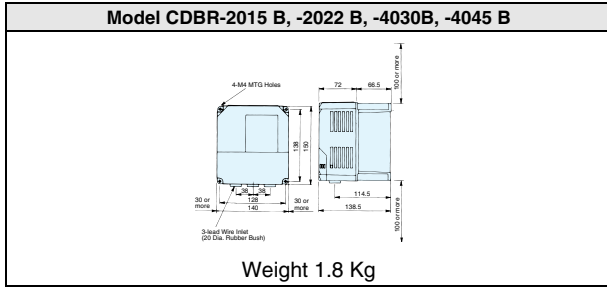

Braking resistor unit (Inverter-mounted type)



Weight: 0.2 kg
Model ERF-150WJ_

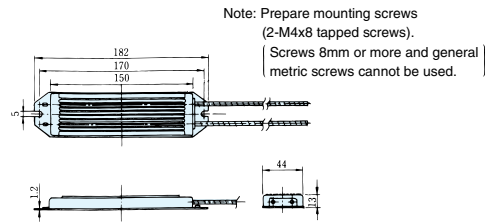

Braking resistor unit (separately-installed type)

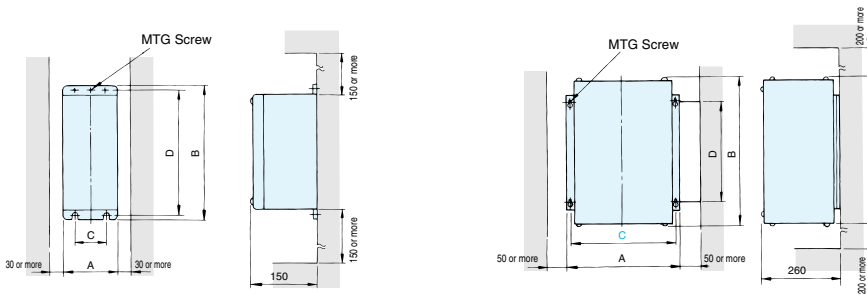

Voltage	Model LKEB-__	Dimensions in mm					Weight kg
		A	B	C	D	MTG screw	
220 V class	23P7	130	350	75	335	M5 x 4	5.0
	25P5	250	350	200	335	M6 x 4	7.5
	27P5	250	350	200	335	M6 x 4	8.5
400 V class	44P0	130	350	75	335	M5 x 4	5.0
	45P5	250	350	200	332	M6 x 4	7.5
	47P5	250	350	200	332	M6 x 4	8.5
220 V class	2011	266	543	246	340	M8 x 4	10
	2015	356	543	336	340	M8 x 4	15
	2018	446	543	426	340	M8 x 4	19
	2022	446	543	426	340	M8 x 4	19
400 V class	4011	350	412	330	325	M6 x 4	16
	4015	350	412	330	325	M6 x 4	18
	4018	446	543	426	340	M8 x 4	19
	4022	446	543	426	340	M8 x 4	19
	4030	356	956	336	740	M8 x 4	25
	4045	446	956	426	740	M8 x 4	33

Attachments

Heatsink external mounting attachment

The Varispeed L7 inverters under the 200/400 V class 18.5 kW or less need this attachment for mounting the heatsink externally. This attachment expands the outer dimensions of the width and height of the inverter. (Attachment is not required for inverters of 22 kW or more.)

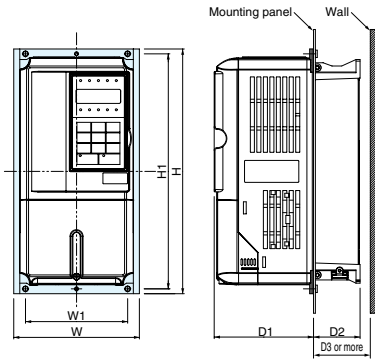

Model CIMR-L7Z_	Attachment order code	Dimensions in mm						
		W	H	W1	H1	D1	D2	D3
23P7	EZZ08676A	155	302	126	290	122.6	57.4	60
25P5								
27P5								
2011	EZZ08676B	210	330	180	316	136.1	63.4	70
2015								
2018								
2015	EZZ08676C	250	392	216	372	133.6	76.4	85
2018								
40P4								
45P5	EZZ08676A	155	302	126	290	122.6	57.4	60
47P5								
4011								
4015	EZZ08676B	210	330	180	316	136.1	63.4	70
4018								
4015								
4018	EZZ08676C	250	392	216	372	133.6	76.4	85

Panel cut for external mounting of cooling fin (heatsink)

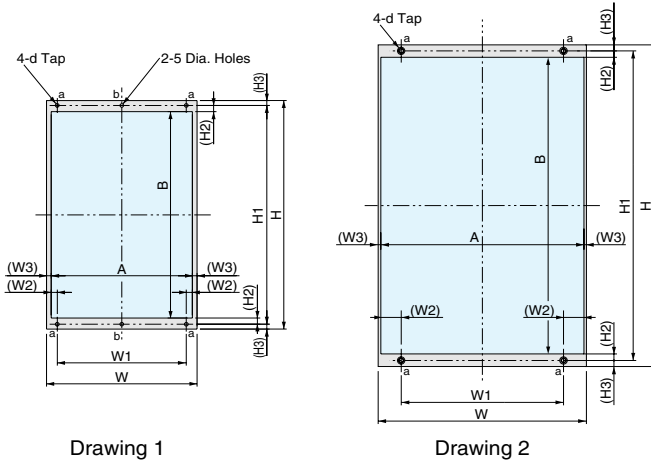

Drawing 1

Drawing 2

Model CIMR-L7Z_	Drawing	Dimensions in mm											
		W	H	W1	(W2)	(W3)	H1	(H2)	(H3)	A	B	d	
23P7	1	155	302	126	6	8.5	290	9.5	6	138	271	M5	
25P5													
27P5			210	330	180	8.5	6.5	316	9	7	197	298	M6
2011							8.5	372	9.5	10	233	353	
2015			250	392	216								
2018													
2022	2	250	400	195	24.5	3	385	8	7.5	244	369	M6	
2030			275	450	220			435			269		
2037			375	600	250	54.5	8	575	15	12.5	359		545
2045			450	725	325					700	13.5		5
2055													
44P0	1	155	302	126	6	8.5	290	9.5	6	138	271	M5	
45P5													
47P5			210	330	180	8.5	6.5	316	9	7	197	298	M6
4011							8.5	372	9.5	10	233	353	
4015			250	392	216								
4018													
4022	2	275	450	220	24.5	3	435	8	7.5	269	419		
4030													
4037			325	550	260		8	535			309	519	
4045													
4055													

Installation

Standard connections

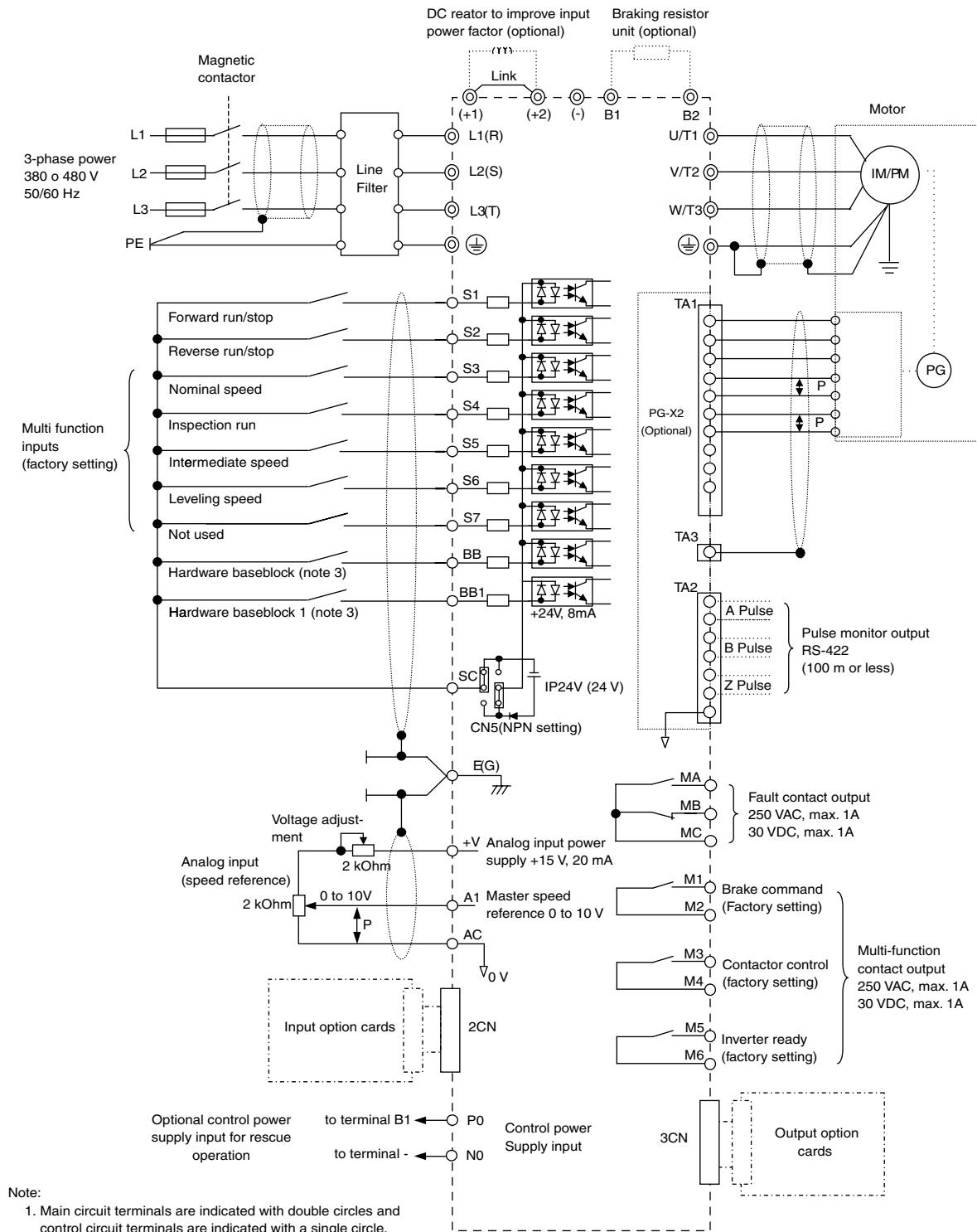

- Note:
1. Main circuit terminals are indicated with double circles and control circuit terminals are indicated with a single circle.
 2. The CN5 factory setting is NPN.
 3. To enable the inverter, both inputs BB and BB1 must be closed. If only one of the inputs is closed, "BB" will be displayed in the operator panel and the inverter will not start.

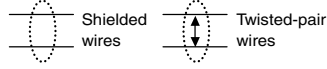

Main circuit

Voltage	200 V			400 V	
	Model CIMR-L7□	20P4 to 2018	2022 and 2030	2037 to 2055	40P4 to 4018
Max. applicable motor output	0.4 to 18.5 kW	22 and 30 kW	37 to 55 kW	0.4 to 18.5 kW	22 to 55 kW
R/L1	Main circuit input power supply	Main circuit input power supply	Main circuit input power supply	Main circuit input power supply	Main circuit input power supply
S/L2					
T/L3					
R1/L11	---	R-R1, S-S1 and T-T1 have been wired before shipment.	---	---	R-R1, S-S1 and T-T1 have been wired before shipment
S1/L21					
T1/L31					
U/T1	Inverter output			Inverter output	
V/T2					
W/T3					
B1	Braking resistor unit	-----		Braking resistor unit	-----
B2					
⊖	DC reactor (⊕1- ⊕2)	Braking unit (⊕3 - ⊖)		DC reactor (⊕1- ⊕2)	Braking unit (⊕3 - ⊖)
⊕1					
⊕2					
⊕3	---	---	Cooling fan power supply	---	---
r / I ₁	---	---		---	---
↳ / I ₂	---	---		---	---
PO	Battery power input			Battery power input	
NO	Ground terminal (100 Ω or less)			Ground terminal (10 Ω or less)	
⊕					

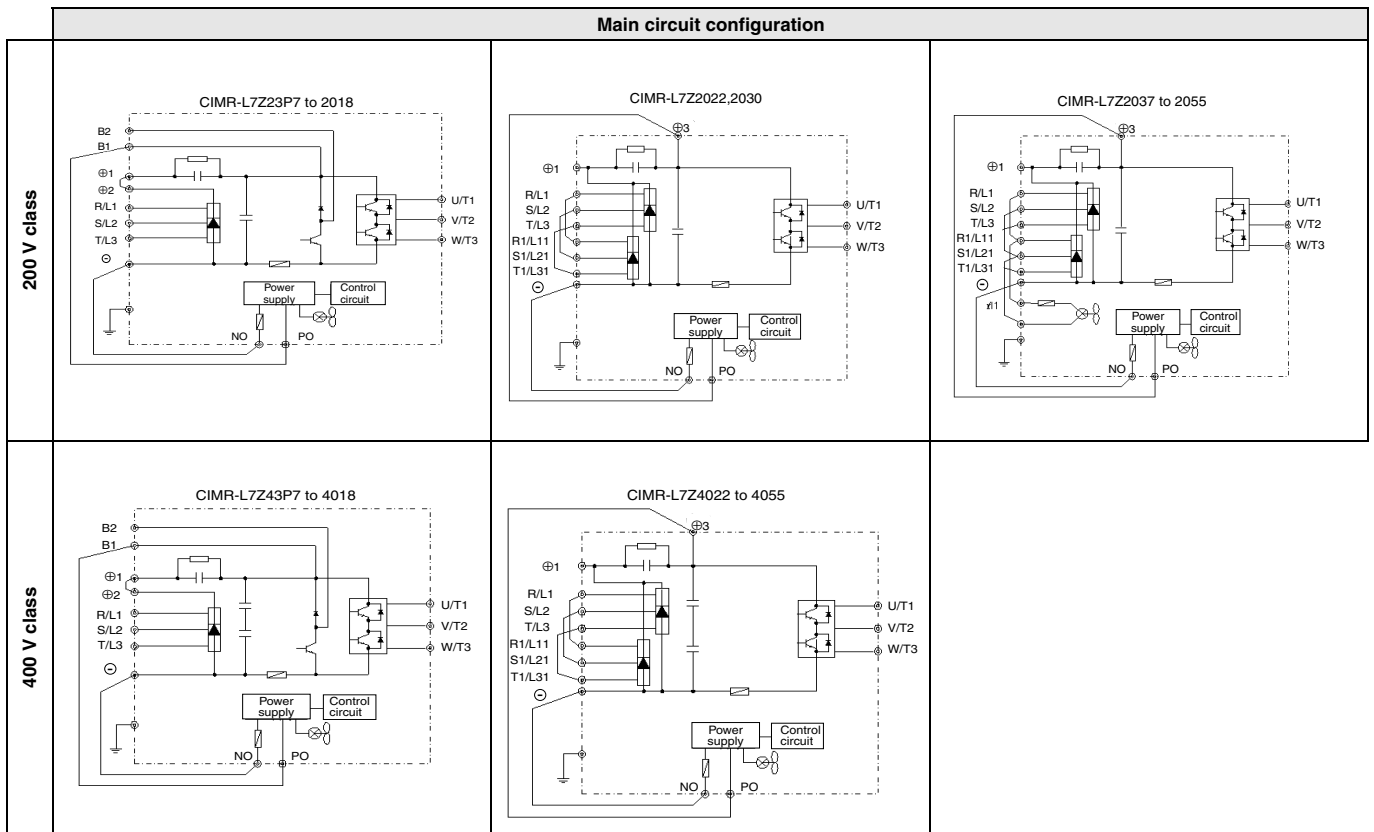

Control circuit

Type	No.	Signal Name	Function	Signal Level
Digital input signals	S1	Forward run/stop command	Forward run when ON; stopped when OFF.	24 VDC, 8 mA photo-coupler
	S2	Reverse run/stop command	Reverse run when ON; stopped when OFF.	
	S3	Nominal speed	Nominal speed when ON.	
	S4	Inspection run	Inspection RUN when ON.	
	S5	Intermediate speed	Intermediate speed when ON.	
	S6	Leveling speed	Leveling speed when ON.	
	S7	Not used	-	
	BB	Hardware baseblock	Safety inputs. To enable the inverter, both inputs BB and BB1 must be closed. If only one of them is closed, "BB" will be displayed in the operator panel and the inverter will not start.	
	BB1	Hardware baseblock 1		
	SC	Digital input common	-	
Analog input signals	+V	15 V power output	15 V power supply for analog references	15 V (max. current: 20 mA)
	A1	Frequency reference	0 to +10 V/100%	0 to +10 V(20 kΩ)
	AC	Analog reference neutral	-	-
	E(G)	Shield wire, optional ground line connection point	-	-
Sequence output signals	M1	Brake command (1NO contact)	Brake command when ON	Multi-function contact outputs Relay contacts Contact capacity: 1 A max. at 250 VAC 1 A max. at 30 VDC
	M2			
	M3	Contactor control (1NO contact)	Contactor control when ON	
	M4			
	M5	Inverter ready (1NO contact)	Inverter ready when ON	
	M6			
	MA	Fault output signal (SPDT) (1 change over contact)	Fault when CLOSED across MA and MC Fault when OPEN across MB and MC	
	MB			
MC				

When driving a reactive load, such as relay coil with DC power supply, always insert a flywheel diode

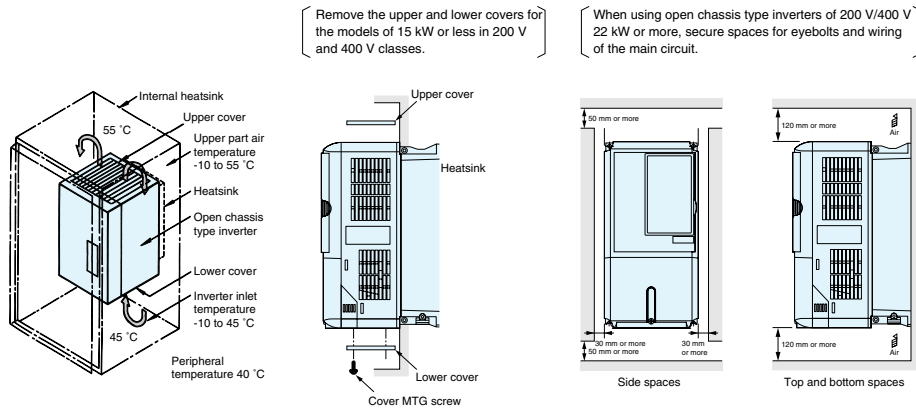

Inverter heat loss

200 V class

Model CIMR-L7Z□		23P7	25P5	27P5	2011	2015	2018	2022	2030	2037	2045	2055
Inverter capacity	kVA	5.7	8.8	12	17	22	27	32	44	55	69	82
Rated current	A	15	23	31	45	58	71	85	115	145	180	215
Heat loss W	Fin	W	112	164	219	374	429	501	586	865	1015	1588
	Inside unit	W	74	84	113	170	183	211	274	352	411	619
	Total heat loss	W	186	248	332	544	612	712	860	1217	1426	2207
Fin coding		Fan cooled										

400 V class

Model CIMR-L7Z□		44P0	45P5	47P5	4011	4015	4018	4022	4030	4037	4045	4055
Inverter capacity	kVA	5.8	9.5	13	18	24	30	34	46	57	69	85
Rated current	A	7.6	12.5	17	24	31	39	45	60	75	91	112
Heat loss W	Fin	W	91	127	193	252	326	426	466	678	784	1203
	Inside unit	W	70	82	114	158	172	208	259	317	360	495
	Total heat loss	W	161	209	307	410	498	634	725	995	1144	1316
Fin coding		Fan cooled										

Connections for braking resistors

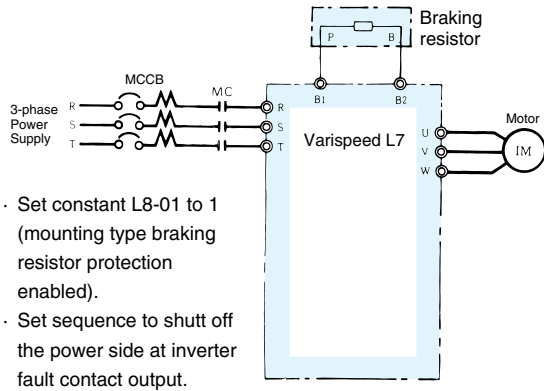

- Set constant L8-01 to 1 (mounting type braking resistor protection enabled).
- Set sequence to shut off the power side at inverter fault contact output.

Connections for braking units

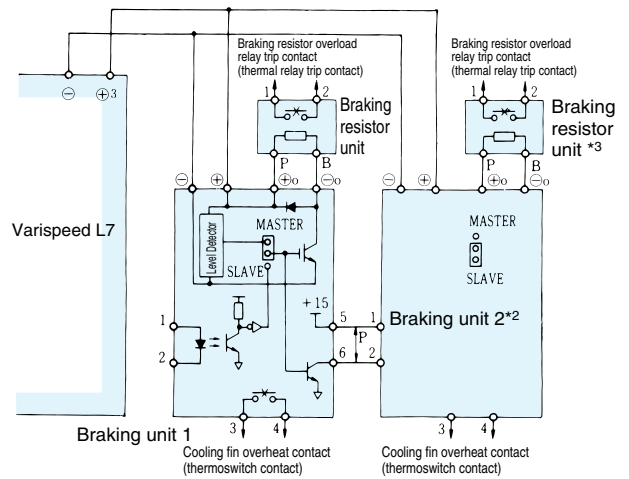

AC reactor

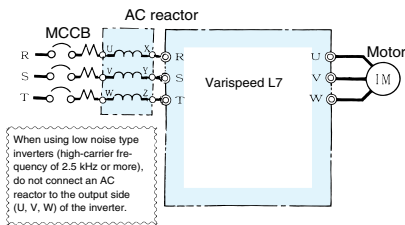

When using low noise type inverters (high-carrier frequency of 2.5 kHz or more), do not connect an AC reactor to the output side (U, V, W) of the inverter.

200 V class			400 V class		
Max. applicable motor output kW	Current value A	Inductance mH	Max. applicable motor output kW	Current value A	Inductance mH
4.0	20	0.53	4.0	10	2.2
5.5	30	0.35	5.5	15	1.42
7.5	40	0.265	7.5	20	1.06
11	60	0.18	11	30	0.7
15	80	0.13	15	40	0.53
18.5	90	0.12	18.5	50	0.42
22	120	0.09	22	60	0.36
30	160	0.07	30	80	0.26
37	200	0.05	37	90	0.24
45	240	0.044	45	120	0.18
55	280	0.038	55	150	0.15

DC reactor

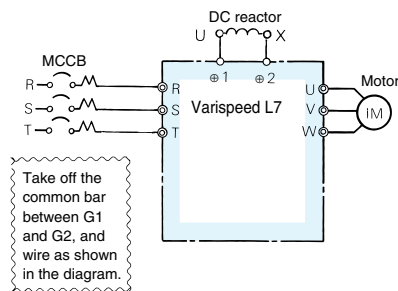

Take off the common bar between G1 and G2, and wire as shown in the diagram.

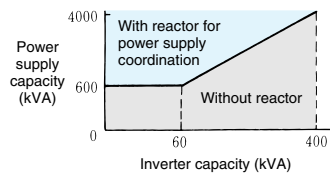

200 V class			400 V class		
Max. applicable motor output kW	Current value A	Inductance mH	Max. applicable motor output kW	Current value A	Inductance mH
4.0	18	3	4.0	12	6.3
5.5	36	1	5.5	23	3.6
7.5					
11	72	0.5	11	33	1.9
15					
18.5	90	0.4	18.5	47	1.3
22 to 55	Built-in		22 to 55	Built-in	

Fuse installation

To protect the inverter, it is recommended to use semiconductor fuses as shown in the table below

Inverter type	FUSE		
	Voltage (V)	Current (A)	I ² t (A ² s)
23P7	240	30	82~220
25P5	240	40	220~610
27P5	240	60	290~1300
2011	240	80	450~5000
2015	240	100	1200~7200
2018	240	130	1800~7200
2022	240	150	870~16200
2030	240	180	1500~23000
2037	240	240	2100~19000
2045	240	300	2700~55000
2055	240	350	4000~55000
43P7	480	15	34~72
44P0	480	20	50~570
45P5	480	25	100~570
47P5	480	30	100~640
4011	480	50	150~1300
4015	480	60	400~1800
4018	480	70	700~4100
4022	480	80	240~5800
4030	480	100	500~5800
4037	480	125	750~5800
4045	480	150	920~13000
4055	480	150	1500~13000

Rescue system

Example 1: 1phase, 230V UPS power supply.

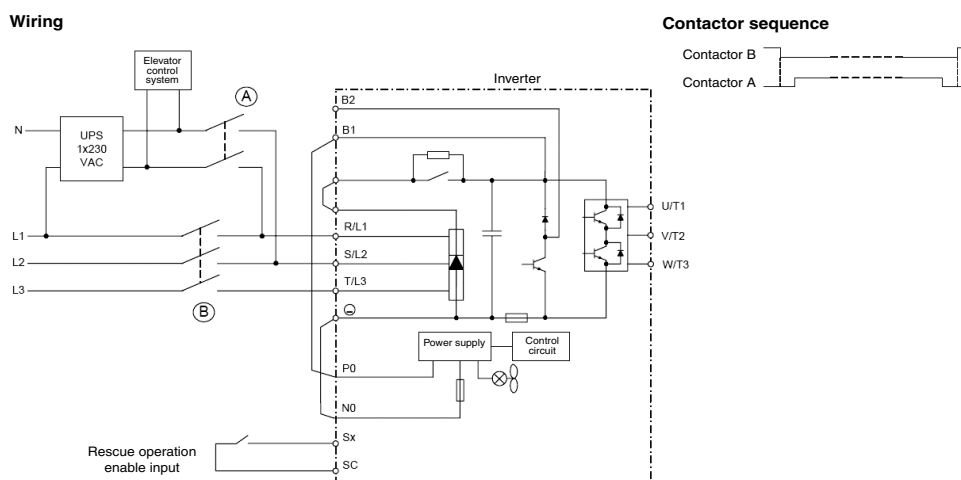

Example 2: two batteries.

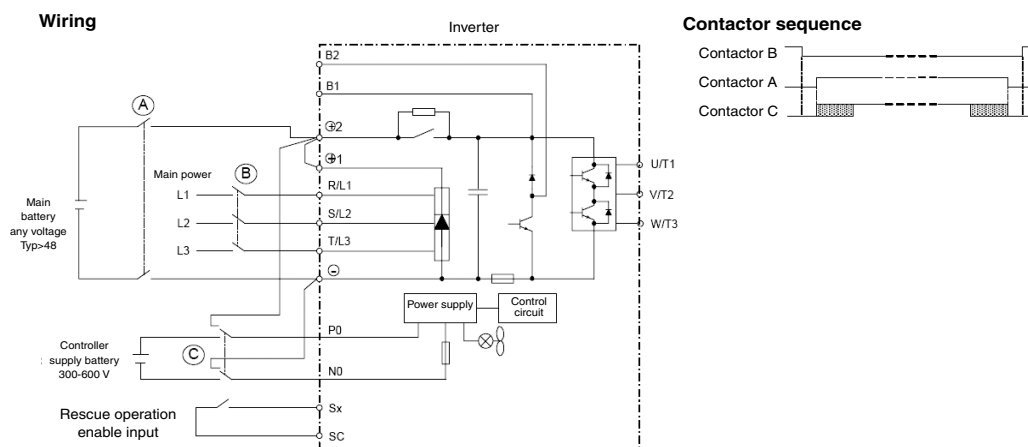

Safety system

Example: EN81-1:1998 compliant installation of L7 with one motor contactor

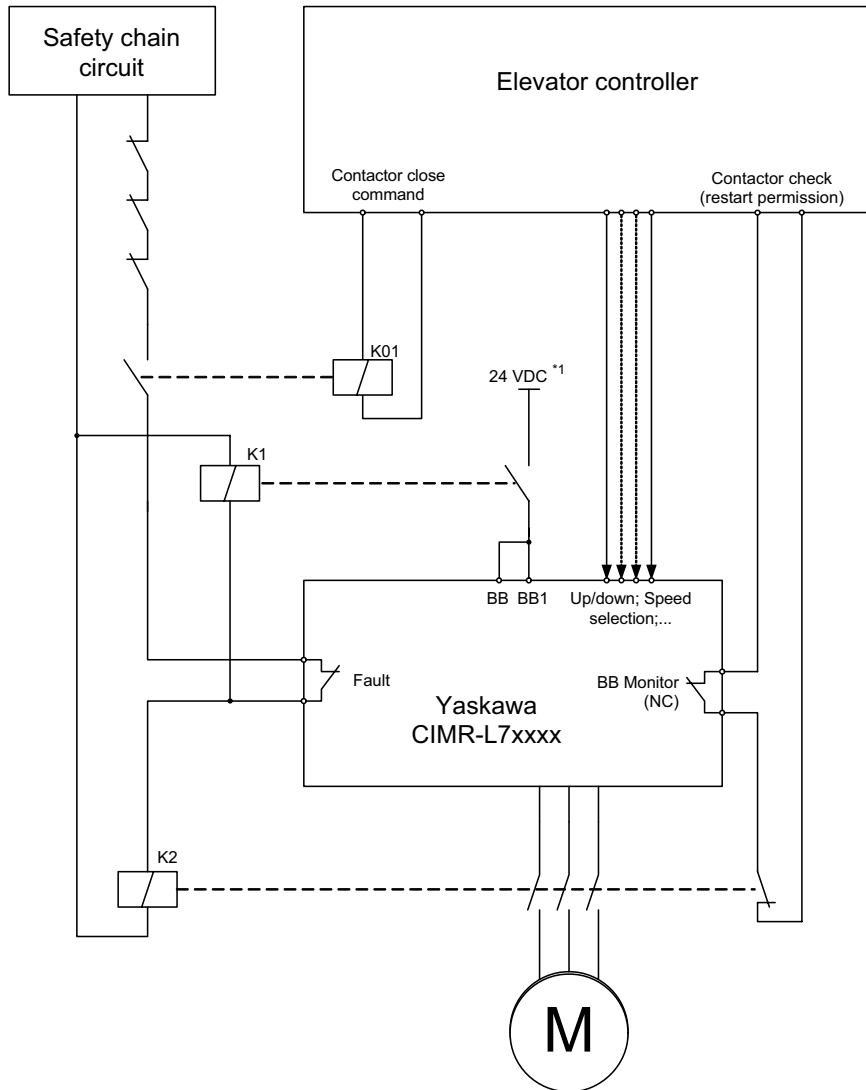

1. The polarity of this 24 VDC signal depends on the polarity selection for the drives digital inputs. The internal as well as any external 24 VDC power supply can be used.

Ordering information

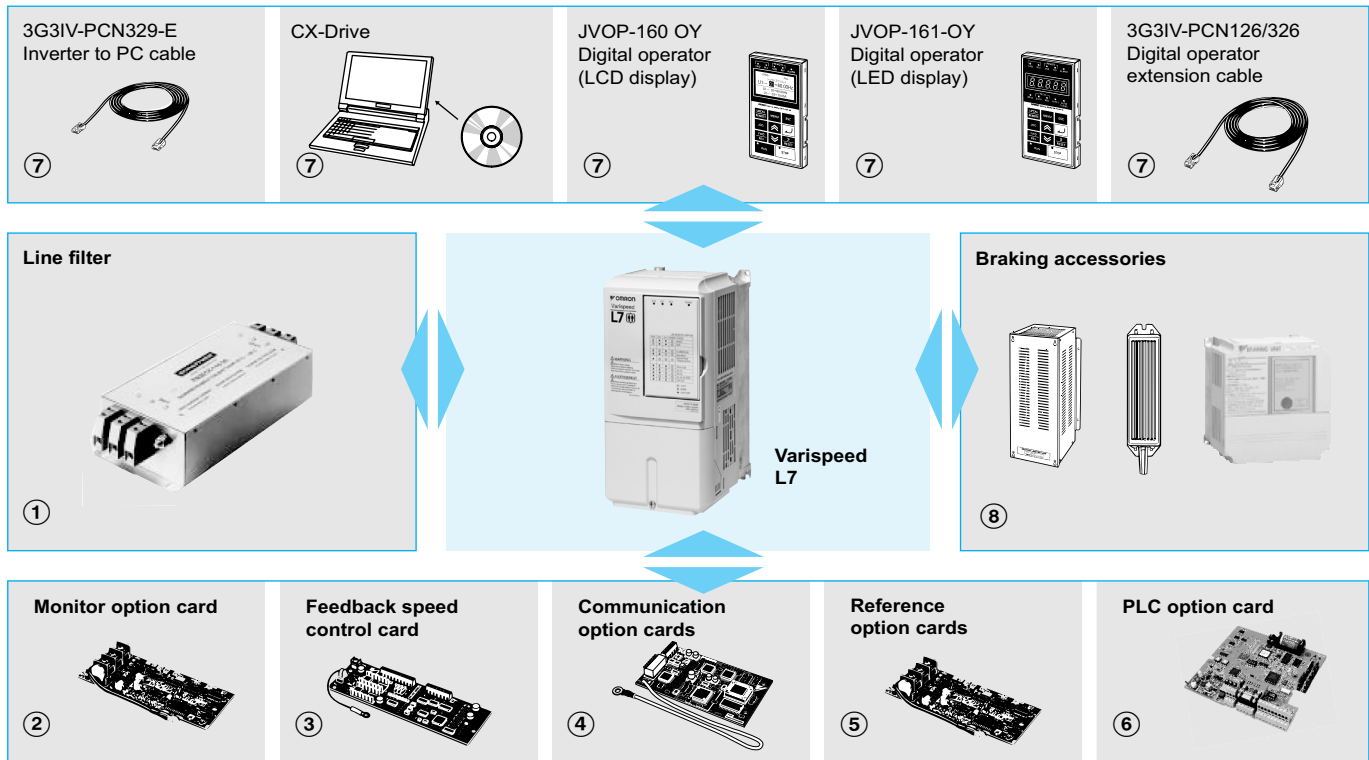

Varispeed L7



200 V

Specifications			Model
3x200 V	3.7 Kw	17.5 A	CIMR-L7Z23P7
	5.5 Kw	25 A	CIMR-L7Z25P5
	7.5 Kw	33 A	CIMR-L7Z27P5
	11 Kw	49 A	CIMR-L7Z2011
	15 Kw	64 A	CIMR-L7Z2015
	18.5 Kw	80 A	CIMR-L7Z2018
	22 Kw	96 A	CIMR-L7Z2022
	30 Kw	130 A	CIMR-L7Z2030
	37 Kw	160 A	CIMR-L7Z2037
	45 Kw	183 A	CIMR-L7Z2045
55 Kw	224 A	CIMR-L7Z2055	

400 V

Specifications			Model
3x400 V	4.0 Kw	11 A	CIMR-L7Z44P0
	5.5 Kw	14 A	CIMR-L7Z45P5
	7.5 Kw	18 A	CIMR-L7Z47P5
	11 Kw	27 A	CIMR-L7Z4011
	15 Kw	34 A	CIMR-L7Z4015
	18.5 Kw	41 A	CIMR-L7Z4018
	22 Kw	48 A	CIMR-L7Z4022
	30 Kw	65 A	CIMR-L7Z4030
	37 Kw	80 A	CIMR-L7Z4037
	45 Kw	96 A	CIMR-L7Z4045
	55 Kw	128 A	CIMR-L7Z4055

① Input filters

Footprint / bookform filters



200 V

400 V

Inverter model	Line filters			
	Type	EN55011 class	Current (A)	Weight (kg)
CIMR-L7Z23P7	3G3RV-PFI2035-SE	B, 25 m	35	1.4
CIMR-L7Z25P5		A 100 m		
CIMR-L7Z27P5	3G3RV-PFI2060-SE	B, 25 m	60	3
CIMR-L7Z2011		A 100 m		
CIMR-L7Z2015	3G3RV-PFI2100-SE	B, 25 m	100	4.9
CIMR-L7Z2018		A 100 m		
CIMR-L7Z2022	3G3RV-PFI2130-SE	B, 25 m	130	4.3
CIMR-L7Z2030		A 100 m		
CIMR-L7Z2037	3G3RV-PFI2160-SE	A, 100 m	160	6.0
CIMR-L7Z2045	3G3RV-PFI2200-SE	B, 25 m	200	11.0
CIMR-L7Z2055		A 100 m		

Inverter model	Line filters			
	Type	EN55011 class	Current (A)	Weight (kg)
CIMR-L7Z44P0	3G3RV-PFI3018-SE	B, 25 m	18	1.3
CIMR-L7Z45P5		A 100 m		
CIMR-L7Z47P5	3G3RV-PFI3021-SE	B, 25 m	21	1.8
CIMR-L7Z4011	3G3RV-PFI3035-SE	B, 25 m	35	2.2
CIMR-L7Z4015		A 100 m		
CIMR-L7Z4018	3G3RV-PFI3060-SE	B, 25 m	60	4.0
CIMR-L7Z4022		A 100 m		
CIMR-L7Z4030	3G3RV-PFI3070-SE	B, 25 m	70	3.4
CIMR-L7Z4037		A 100 m		
CIMR-L7Z4045	3G3RV-PFI3100-SE	A, 100 m	100	4.5
CIMR-L7Z4055	3G3RV-PFI3130-SE	A, 100 m	130	4.7

① Input filters

Bottom filters



Inverter model	Line filters			
	Type	EN55011 class	Current (A)	Weight (kg)
CIMR-L7Z44P0	3G3RV-PFI3018B-SE	B, 25 m	18	1,0
CIMR-L7Z45P5		A 100 m		
CIMR-L7Z47P5	3G3RV-PFI3035B-SE	B, 25 m	35	1,5
CIMR-L7Z4011		A 100 m		
CIMR-L7Z4015	3G3RV-PFI3060B-SE	B, 25 m	60	2,2
CIMR-L7Z4018		A 100 m		

② Monitor option cards

Type	Model	Description	Function
Monitor option card	DO-08 / 3G3IV-PDO08	Digital output card	Outputs isolated type digital signal for monitoring inverter run state (alarm signal, zero speed detection etc.). Output channel: Photo coupler 6 channels (48 V, 50 mA or less) Relay contact output 2 channels (250 VAC, 1 A or less) 30 VDC, 1 A or less
	DO-02C / 3G3IV-PDO02C	2C-relay output card	• Two multi-function contact outputs (2C-relay) can be used other than those of the inverter proper unit.

③ Feedback speed control cards

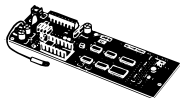
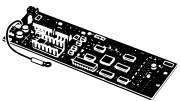
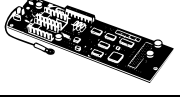
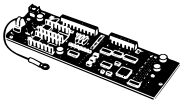
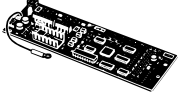
Type	Model	Description	Function
Feedback speed control card	PG-A2 / 3G3FV-PPGA2 	PG speed controller card (used for V/f control with PG or flux vector)	<ul style="list-style-type: none"> Phase A pulse (single pulse) inputs (voltage, complementary, open collector input) PG frequency range: Approx. 30 kHz max. [Power supply output for PG: +12 V, max. current 200 mA] Pulse monitor output: +12 V, 20 mA
	PG-B2 / 3G3FV-PPGB2 		<ul style="list-style-type: none"> Phase A and B pulse inputs (exclusively for complementary input) PG frequency range: Approx. 30 kHz max. [Power supply output for PG: +12 V, max. current 200 mA] Pulse monitor output: Open collector, +24 V, Max. current 30 mA
	PG-D2 / 3G3FV-PPGD2 		<ul style="list-style-type: none"> Phase A pulse (differential pulse) input for V/f control (RS-422 input) PG frequency range: Approx. 300 kHz max. [Power supply output for PG: +5 V or +12 V, max. current 200 mA] Pulse monitor output: RS-422
	PG-X2 / 3G3FV-PPGX2 		<ul style="list-style-type: none"> Phase A, B and Z pulse (differential pulse) inputs (RS-422 input) PG frequency range: Approx. 300 kHz max. [Power supply output for PG: +5 V or +12 V, max. current 200 mA] Pulse monitor output: RS-422
	PG-F2 		<ul style="list-style-type: none"> Hiperface and endat encoder option.

④ Communication option cards

Type	Model	Description	Function
Communication option card	SI-N1	DeviceNet option card	• Used for running or stopping the inverter, setting or referencing parameters, and monitoring output frequency, output current, or similar items through DeviceNet communication with the host controller.
	SI-P1	PROFIBUS-DP option card	• Used for running or stopping the inverter, setting or referencing parameters, and monitoring output frequency, output current, or similar items through PROFIBUS-DP communication with the host controller.
	SI-S1	CANopen option card	<ul style="list-style-type: none"> Used for running or stopping the inverter, setting or referencing parameters, and monitoring output frequency, output current, or similar items through CANopen communication with the host controller. It supports DSP402 CANopen standard protocol for drives control in speed control.
	SI-J	LONWORKS option card	• Used for HVAC control, running or stopping the inverter, setting or referencing parameters, and monitoring output current, watt-hours, or similar items through LONWORKS communications with peripheral devices.

⑤ Reference option cards

Type	Model	Description	Function
Reference option card	AI-14U / 3G3IV-PAI14U	Analog input card	<ul style="list-style-type: none"> 2 channel high resolution analog input card Channel 1: 0 to 10 V (20 KΩ) Channel 2: 4 to 20 mA (250 Ω) Resolution 14 bit
	AI-14B / 3G3IV-PAI14B		<ul style="list-style-type: none"> 3 channel high resolution analog input card Signal level: -10 to +10V (20 KΩ) 4 to 20 mA (250 Ω) Resolution: 13 bit + sign
	DI-08 / 3G3IV-PDI08	Digital reference card	• 8 bit digital speed reference input card
	DI-16H2 / 3G3IV-PDI16H2		• 16 bit digital speed reference input card

⑥ PLC option boards

Type	Model	Description	Function
PLC option	3G3RV-P10ST8-E	PLC option	<ul style="list-style-type: none"> Full PLC features, wireless installation and seamless access to the inverter parameters and analogue/digital inputs and outputs. Embedded Compubus/S fieldbus Standard OMRON tools can be used for programming
	3G3RV-P10ST8-DRT-E	PLC option with DeviceNet	<ul style="list-style-type: none"> Same features as standard models with DeviceNet support.



⑦ Accessories

Type	Model	Description	Installation / Function
Digital operator	JVOP-160-OY	5 lines LCD digital operator 7 language support	
	JVOP-161-OY	7 segment LED digital operator	
Accessories	3G3IV-PCN126 3G3IV-PCN326	Digital operator extension cable 1 meter 3 meters	Extension cable to connect inverter and digital operator
	3G3IV-PCN329-E	PC configuration cable	Cable to connect inverter to PC

⑦ Accessories

Symbol	Model	Description	Function
Software	CX-drive	Computer software	Configuration and monitoring software tool for drives.
	CX-One	Computer software	Complete OMRON automation software including CX-drive.

⑧ Braking Unit, braking resistor unit

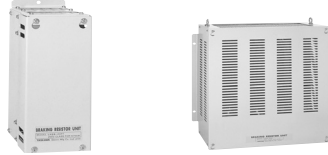
Inverter			Braking unit 		Braking resistor unit ¹										
					Inverter-mounted type (3 %ED, 10 sec max) ² 				Separately-installed type (10 %ED, 10 sec. max.) ³ 						
Voltage	Max. applicable motor output kW	Model CIMR-L7Z_	Model CDBR_	No. of used	Model ERF-150WJ_	Resistance	No. of used	Braking Torque %	Model LKEB_	Specifications of resistor	No. of used	Braking torque %	Connectable min resistance value Ω		
200 V class	3.7	23P7	Built-in	---	620	62 Ω	1	100	23P7	390 W	40 Ω	1	125	16	
	5.5	25P5							25P5	520 W	30 Ω	1	115	16	
	7.5	27P5							27P5	780 W	20 Ω	1	125	9.6	
	11	2011							2011	2400 W	13.6 Ω	1	125	9.6	
	15	2015							2015	3000 W	10 Ω	1	125	9.6	
	18.5	2018							2015	3000 W	10 Ω	1	125	9.6	
	22	2022							2022	4800 W	6.8 Ω	1	125	6.4	
	30	2030							2015B	3000 W	10 Ω	2	125	9.6	
	37	2037							2015B	3000 W	10 Ω	2	100	9.6	
	45	2045							2022B	4800 W	6.8 Ω	2	120	6.4	
55	2055	2022B	4800 W	6.8 Ω	2	100	6.4								
400 V class	4.0	44P0	Built in	---	201	200 Ω	1	110	44P0	390 W	150 Ω	1	135	32	
	5.5	45P5							45P5	520 W	100 Ω	1	135	32	
	7.5	47P5							47P5	780 W	75 Ω	1	130	32	
	11	4011							4011	1040 W	50 Ω	1	135	20	
	15	4015							4015	1560 W	40 Ω	1	125	20	
	18.5	4018							4018	4800 W	32 Ω	1	125	19.2	
	22	4022							4022	4800 W	27.2 Ω	1	125	19.2	
	30	4030							4030B	6000 W	20 Ω	1	125	19.2	
	37	4037							4045B	9600 W	16 Ω	1	125	12.8	
	45	4045							4045B	9600 W	13.6 Ω	1	125	12.8	
55	4055	4030B	6000 W	20 Ω	2	135	19.2								

1. When connecting a mounting type resistor or braking resistor unit, set system constant L3-04 to 0 (stall prevention disabled during deceleration). If operating without changing the constant, motor does not stop at set deceleration time.
2. When connecting mounting type braking resistor, set system constant L8-01 to 1 (braking resistor protection enabled).
3. Load factor during deceleration to stop a load with constant torque. With constant output or continuous regenerative braking, the load factor is smaller than the specified value.
4. Resistance value per one braking unit. Select a resistance value that is larger than connectable minimum resistance value to obtain enough braking torque.
5. For an application with large regenerative power such as hoisting, the braking torque or other items may exceed the capacity of a braking unit with a braking resistor in a standard combination (can result in capacity overload). Contact your OMRON representatives when the braking torque or any other item exceeds the values in the table.

ALL DIMENSIONS SHOWN ARE IN MILLIMETERS.

To convert millimeters into inches, multiply by 0.03937. To convert grams into ounces, multiply by 0.03527.