

mitsubishi

GT15 MELSECNET/H

communication unit

User's Manual

GT15-J71LP23-25

GT15-J71BR13

Thank you for purchasing the GOT1000 Series.

Prior to use, please read both this manual and detailed manual thoroughly to fully understand the product.

MODEL	GT15-J71LP23-25-U
MODEL CODE	1D7M56
IB(NA)-0800350-G(1106)MEE	

GRAPHIC OPERATION TERMINAL

GOT1000

●SAFETY PRECAUTIONS●

(Always read these precautions before using this equipment.)

Before using this product, please read this manual and the relevant manuals introduced in this manual carefully and pay full attention to safety to handle the product correctly.

The precautions given in this manual are concerned with this product.

In this manual, the safety precautions are ranked as "DANGER" and "CAUTION".



DANGER

Indicates that incorrect handling may cause hazardous conditions, resulting in death or severe injury.



CAUTION

Indicates that incorrect handling may cause hazardous conditions, resulting in medium or slight personal injury or physical damage.

Note that the  CAUTION level may lead to a serious accident according to the circumstances.

Always follow the precautions of both levels because they are important to personal safety.

Please save this manual to make it accessible when required and always forward it to the end user.

[DESIGN PRECAUTIONS]

DANGER

- If a communication fails in data link, the faulty station holds the data link data generated before the communication error. Create an interlock circuit in the sequence program using the communication status information in order that the system will operate safely.
Check the faulty station and the operation status during communication error by referring to the relevant manuals.
- Some failures of cable or communication unit may cause the GOT to keep the outputs on or off.
Create an external circuit for monitoring output signals that may lead to serious accidents.
Failure to do so may cause mis-outputs or malfunctions, resulting in accidents.
- If a communication error (including cable disconnection) occurs during monitoring, the communication between the GOT and PLC CPU may be interrupted and the GOT may be inoperative.
For bus connection : The PLC CPU is down and the GOT is inoperative.
For other than above: The GOT is inoperative.
When configuring a system including the GOT, the possibility of GOT communication error must be considered; make sure the operation significant for the system will be performed by switches on devices other than the GOT.
Failure to do so may cause mis-outputs or malfunctions, resulting in accidents.

CAUTION

- Do not bunch the control wires or communication cables with the main circuit or power wires, or lay them close to each other.
As a guide, separate the lines by a distance of at least 100mm (3.94 inches) otherwise malfunctions may occur due to noise.

[INSTALLATION PRECAUTIONS]

DANGER

- Be sure to shut off all phases of the external power supply used by the system before mounting or removing this unit to/from the GOT.
Not doing so can cause a unit failure or malfunction.

[INSTALLATION PRECAUTIONS]

CAUTION

- Use this unit in the environment that satisfies the general specifications described in the User's Manual for the GOT used.
Not doing so can cause an electric shock, fire, malfunction or product damage or deterioration.
- When installing this unit to the GOT, fit it to the connection interface of the GOT and tighten the mounting screws in the specified torque range.
Undertightening can cause a drop, failure or malfunction.
Overtightening can cause a drop, failure or malfunction due to screw or unit damage.
- Do not directly touch the conductive part or electronic components of the unit.
This may cause the unit to fail or malfunction.

[WIRING PRECAUTIONS]

DANGER

- Be sure to shut off all phases of the external power supply used by the system before wiring.
Failure to do so may cause electric shock, product damage or malfunctions.

CAUTION

- Be careful not to let foreign matter such as dust or wire chips get inside the unit. This may cause a fire, failure or malfunctions.
- Make sure to securely connect the cable to the connector of unit.
Incorrect connection may cause malfunctions.
- Make sure to fix communication cables and power cables to the unit by ducts or clamps. Failure to do so may cause damage of the unit or the cables due to accidental pull or unintentional shifting of the cables, or malfunctions due to poor contact of the cables.
- Do not hold the cable by hand and pull it out from the unit.
When removing the cable from the unit, make sure to hold the connector by hand and pull it.
Failure to do so may cause malfunctions or damage to the unit or cable.
- Solder the coaxial cable connector correctly.
Incomplete soldering may cause a malfunction.

[STARTUP AND MAINTENANCE PRECAUTIONS]



DANGER

- Do not touch the connector while power is on.
Failure to do so may cause electric shock or malfunctions.
- Before starting cleaning, always shut off GOT power externally in all phases.
Not doing so can cause a unit failure or malfunction.



CAUTION

- Do not disassemble or modify any unit.
This will cause failure, malfunction, injuries, or fire.
- Do not touch the conductive areas and electronic parts of this unit directly.
Doing so can cause a unit malfunction or failure.
- Make sure to externally shut off all phases of the power supply before cleaning the unit and retightening unit mounting screws.
Failure to do so may cause the unit to fail or malfunction.
Loose tightening may cause a fall of the unit, short circuits, or malfunctions.
Overtightening may damage the screws and/or the unit, resulting in a fall of the unit, short circuits or malfunctions.
- Always make sure to touch the grounded metal to discharge the electricity charged in the body, etc., before touching the unit.
Failure to do so may cause a failure or malfunctions of the unit.

[DISPOSAL PRECAUTIONS]



CAUTION

- Dispose of this product as industrial waste.

[TRANSPORTATION PRECAUTIONS]

CAUTION

- Make sure to transport the GOT main unit and/or relevant unit(s) in the manner they will not be exposed to the impact exceeding the impact resistance described in the general specifications of the User's Manual for the GOT used, as they are precision devices.
Failure to do so may cause the unit to fail.
Check if the unit operates correctly after transportation.

REVISIONS

* The manual number is noted at the lower right of the top cover.

Print Date	*Manual Number	Revision
Mar., 2006	IB(NA)-0800350-A	First edition
May, 2006	IB(NA)-0800350-B	Partial corrections Chapter 2
Sep., 2006	IB(NA)-0800350-C	Partial addition Chapter 1 Addition Compliance with the EMC and Low Voltage Directives
Jul., 2007	IB(NA)-0800350-D	Partial corrections Compliance with the EMC and Low Voltage Directives, Chapter 2, 4, 7
Jan., 2009	IB(NA)-0800350-E	Partial addition Chapter 1, 4, 7
Jun., 2009	IB(NA)-0800350-F	Partial corrections Compliance with the EMC and Low Voltage Directives
Jun., 2011	IB(NA)-0800350-G	Partial corrections Chapter 7 Partial addition Compliance with the Radio Waves Act (South Korea)

This manual confers no industrial property rights or any rights of any other kind, nor does it confer any patent licenses. Mitsubishi Electric Corporation cannot be held responsible for any problems involving industrial property rights which may occur as a result of using the contents noted in this manual.

© 2006 MITSUBISHI ELECTRIC CORPORATION

CONTENTS

1. OVERVIEW	1
2. SPECIFICATIONS	2
3. PART NAMES	4
4. INSTALLATION PROCEDURE	8
5. PRECAUTIONS FOR LAYING CABLES	10
5.1 Precautions for cable connection (GT15-J71LP23-25)	10
5.2 Precautions for cable connection (GT15-J71BR13)	12
6. WIRING METHOD	14
7. EXTERNAL DIMENSIONS	15

Manuals

The following shows manuals relevant to this product.

Detailed Manual

Manual name	Manual number (Model code)
GT16 User's Manual (Hardware) (Sold separately)	SH-080928ENG (1D7MD3)
GT15 User's Manual (Sold separately)	SH-080528ENG (1D7M23)
GOT1000 Series Connection Manual (Mitsubishi Products) for GT Works3 (Sold separately)	SH-080868ENG (1D7MC2)

Relevant Manuals

For relevant manuals, refer to the PDF manuals stored in the CD-ROM for the drawing software used.

Compliance with the EMC and Low Voltage Directives

To configure a system meeting the requirements of the EMC and Low Voltage Directives when incorporating the Mitsubishi GOT (EMC and Low Voltage Directives compliant) into other machinery or equipment, refer to "EMC AND LOW VOLTAGE DIRECTIVES" of the General Description included with the GOT used.

The CE mark, indicating compliance with the EMC and Low Voltage Directives, is printed on the rating plate of the GOT.

Compliance with the Radio Waves Act (South Korea)

This product complies with the Radio Waves Act (South Korea).

Note the following when using the product in South Korea.

이 기기는 업무용 (A급) 전자파적합기기로서 판매자 또는 사용자는 이 점을 주의하시기 바라며, 가정외의 지역에서 사용하는 것을 목적으로 합니다.
(The product is for business use (Class A) and meets the electromagnetic compatibility requirements. The seller and the user must note the above point, and use the product in a place except for home.)

Packing List

The following items are included.

Model	Product	Quantity
GT15-J71LP23-25	MELSECNET/H communication unit	1
	Mounting screw set (2 screws, 2 stickers)	2
	Extend interface relay board	1
GT15-J71BR13*1	MELSECNET/H communication unit	1
	F-type connector (A6RCON-F)	1
	Mounting screw set (2 screws, 2 stickers)	2
	Extend interface relay board	1

*1 : In the case of coaxial-type network system, terminal resistors must be attached to both terminal stations of the network. The GT15-J71BR13 does not include terminal resistors (A6RCON-R75:75Ω). Therefore, they should be prepared by the user.

1. OVERVIEW

This manual explains the GT15-J71LP23-25 and GT15-J71BR13 (hereinafter referred to as MELSECNET/H communication unit).

The MELSECNET/H communication unit allows the GOT 1000 series to function as a normal station (MELSECNET/H connection, MELSECNET/10 connection) in the MELSECNET/H network system (PLC to PLC network) and MELSECNET/10 network system (PLC to PLC network).

Refer to the User's Manual for the GOT used for GOT to which this unit can be installed.

When using the MELSECNET/H or MELSECNET/10 connection, make the communication setting to perform communication with PLCs.

For system configuration when connecting the GOT to the MELSECNET/H or MELSECNET/10 system, refer to GOT1000 Series Connection Manual.

2. SPECIFICATIONS

The performance specifications of the MELSECNET/H communication unit are indicated below.

The general specifications of the MELSECNET/H communication unit are the same as those of the GOT.

For the general specifications of the GOT, refer to the User's Manual for the GOT used. *1

Item	GT15-J71LP23-25		GT15-J71BR13	
Maximum number of link points per network		MELSECNET/H mode MELSECNET/H Extended mode*2 MELSECNET/10*2	MELSECNET/H mode*2	
	LX/LY	8192 points	8192 points	
	LB	16384 points	8192 points	
	LW	16384 points	8192 points	
Maximum number of link points per station	<ul style="list-style-type: none"> MELSECNET/H mode, MELSECNET/10 mode $\{(B+Y) \div 8 + (2 \times W)\} \leq 2000$ bytes MELSECNET/H Extended mode $\{(B+Y) \div 8 + (2 \times W)\} \leq 35840$ bytes 			
Communication speed	10Mbps/25Mbps*3		10Mbps	
Communication method	Token ring method		Token bus method	
Synchronous method	Frame synchronous			
Type of transmission channel	Double loop (Optical fiber cable)		Coaxial single bus	
Total extension distance	30km (98430ft)		3C-2V: 300m (984.3ft)	5C-2V: 500m (1640.5ft)
			Repeater module (A6BR10, A6BR10-DC) Maximum expansion is 2.5km (8203ft)	
Distance between stations*4	During 25Mbps	During 10Mbps	3C-2V: 300m (984.3ft)	5C-2V: 500m (1640.5ft)
	SI optical cables :200m(656.2ft)	SI optical cables :500m(1640.5ft)		
	H-PCF optical cables :400m(1312.4ft)	H-PCF optical cables :1km(3281ft)		
	Broad-band H-PCF optical cables :1km(3281ft)	Broad-band H-PCF optical cables :1km(3281ft)		
	QSI optical cables :1km(3281ft)	QSI optical cables :1km(3281ft)		

Item	GT15-J71LP23-25	GT15-J71BR13
Accessible network range	Only the MELSECNET/H or MELSECNET/10 network system to which the GOT is connected	
Maximum number of groups	0 (No group specification)	
Number of stations connected to a network	63 stations	31 stations
RAS functions	<ul style="list-style-type: none"> • Prevention of system down by switching the control station • Loopback in case of error detection or cable disconnection (Specific to GT15-J71LP23-25) • Link channel check for the host station • Abnormality detection by link special relay, resistor • Various diagnostic functions 	
Transient transmission	• N:N communication	
Cable	Optical fiber cable (Arranged by user*5)	3C-3V 5C-2V or equivalent
Applicable connectors	2-core optical connector plug (Arranged by user*5)	BNC-P-3-NiAu (For 3C-2V) BNC-P-5-NiAu (For 5C-2V) Equivalent goods (manufactured by DDK Electronics., LTD.)
Internal current consumption	0.56A	0.77A
Weight	0.18kg (0.40lb)	0.19kg (0.42lb)

- *1 : When installing an extension unit on the MELSECNET/H communication unit, limit the maximum operating ambient temperature by subtracting 5 degrees from operating ambient temperature of the general specifications.
- *2 : The mode of the MELSECNET/H communication unit can be set in the Communication Settings of GT Designer2 or GOT utility.
- *3 : 25Mbps is applied to the MELSECNET/H mode and MELSECNET/H Extended mode only.
- *4 : The distance between stations may be restricted depending on the type of the cable or the number of connected stations. (Refer to Section 5.1 (1), Section 5.2 (1).)
- *5 : Please note that use of optical fiber cable requires the expertise, special tools and dedicated connector for connection. Please contact your local Mitsubishi Electric System Service or representative, for the purchase of the required items.

3. PART NAMES

The following describes part names and LED indications of the MELSECNET/H communication unit.

1) GT15-J71LP23-25

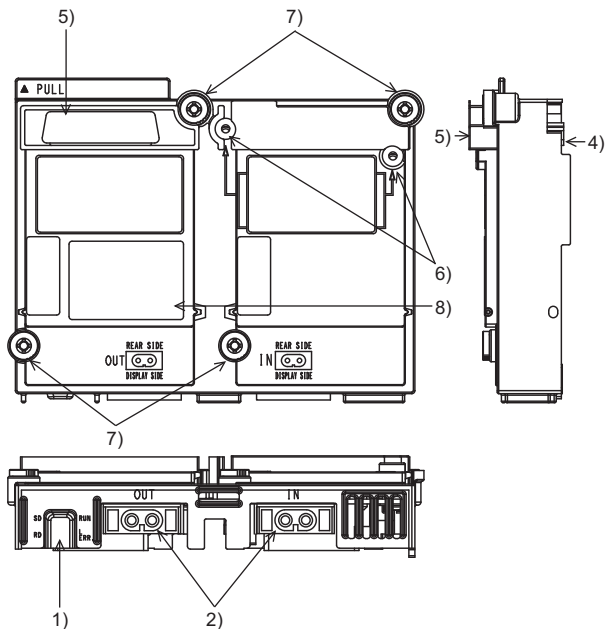

2) GT15-J71BR13

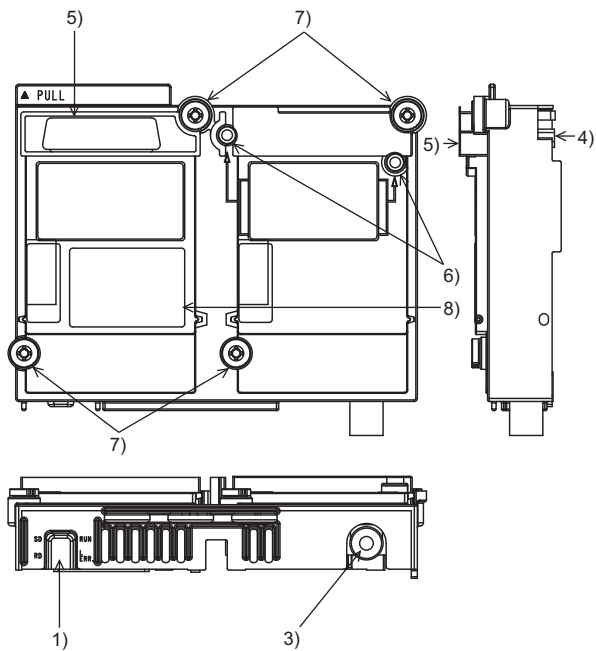

No.	Name	Description																																									
1)	Operation indicator LED SD ○ ○ RUN RD ○ ○ L ERR.	<p>This indicates the status of the MELSECNET/H communication unit and the communication status. When the LED is lighted up, there are two display formats, one for the normal mode and the other for the error mode.</p> <p>(1) Normal Mode If any communication error occurs in the normal mode, specify the error cause by the [NETWK unit status display] screen. Refer to the User's Manual for the GOT used for details on the [NETWK unit status display] screen.</p> <table border="1" data-bbox="325 346 919 681"> <thead> <tr> <th>LED name</th> <th>Status</th> <th>Description</th> </tr> </thead> <tbody> <tr> <td rowspan="2">RUN</td> <td>Off</td> <td>The GOT is being reset.</td> </tr> <tr> <td>Lighted up</td> <td>The unit is in a normal status.</td> </tr> <tr> <td rowspan="2">L ERR.</td> <td>Off</td> <td>The unit is in a normal status.</td> </tr> <tr> <td>Lighted up</td> <td>A communications error has occurred.</td> </tr> <tr> <td rowspan="2">SD</td> <td>Off</td> <td>Data not transmitted.</td> </tr> <tr> <td>Lighted up</td> <td>Data are being transmitted.</td> </tr> <tr> <td rowspan="2">RD</td> <td>Off</td> <td>Data not received.</td> </tr> <tr> <td>Lighted up</td> <td>Data are being received.</td> </tr> </tbody> </table> <p>(2) Error mode When the RUN LED is blinking, the LED display format is the error mode. In the error mode, if an error occurs, restart the GOT. If the error mode is not released after restarting the GOT, the system alarm "460 Communication unit error" may have occurred. For system alarms, refer to the User's Manual for the GOT used.</p> <table border="1" data-bbox="325 914 919 1252"> <thead> <tr> <th>LED name</th> <th>Status</th> <th>Description</th> </tr> </thead> <tbody> <tr> <td rowspan="2">RUN</td> <td>Blinking</td> <td>Shows that it is in the error mode.</td> </tr> <tr> <td>Off Lighted up</td> <td>No error</td> </tr> <tr> <td rowspan="2">L ERR.</td> <td>Off</td> <td>A starting error has not occurred.</td> </tr> <tr> <td>Lighted up</td> <td>A starting error has occurred.</td> </tr> <tr> <td rowspan="2">RD</td> <td>Off</td> <td>A hard ware failure has not occurred.</td> </tr> <tr> <td>Lighted up</td> <td>A hard ware failure has occurred.</td> </tr> </tbody> </table>	LED name	Status	Description	RUN	Off	The GOT is being reset.	Lighted up	The unit is in a normal status.	L ERR.	Off	The unit is in a normal status.	Lighted up	A communications error has occurred.	SD	Off	Data not transmitted.	Lighted up	Data are being transmitted.	RD	Off	Data not received.	Lighted up	Data are being received.	LED name	Status	Description	RUN	Blinking	Shows that it is in the error mode.	Off Lighted up	No error	L ERR.	Off	A starting error has not occurred.	Lighted up	A starting error has occurred.	RD	Off	A hard ware failure has not occurred.	Lighted up	A hard ware failure has occurred.
		LED name	Status	Description																																							
RUN	Off	The GOT is being reset.																																									
	Lighted up	The unit is in a normal status.																																									
L ERR.	Off	The unit is in a normal status.																																									
	Lighted up	A communications error has occurred.																																									
SD	Off	Data not transmitted.																																									
	Lighted up	Data are being transmitted.																																									
RD	Off	Data not received.																																									
	Lighted up	Data are being received.																																									
LED name	Status	Description																																									
RUN	Blinking	Shows that it is in the error mode.																																									
	Off Lighted up	No error																																									
L ERR.	Off	A starting error has not occurred.																																									
	Lighted up	A starting error has occurred.																																									
RD	Off	A hard ware failure has not occurred.																																									
	Lighted up	A hard ware failure has occurred.																																									

No.	Name	Description
2)	Connector (IN side, OUT side) (For GT15-J71LP23-25 only)	Connector for connecting an optical fiber cable
3)	Connector (For GT15-J71BR13 only)	Connector for attaching the F-type connector to connect coaxial cables
4)	Interface connector	Extension connector installed to a front extension unit or the GOT
5)	Extension connector	Extension connector to which a back extension unit is installed
6)	Board fixing screw	Screws for fixing the extension interface relay board
7)	Mounting screw	Mounting screws fixed with a front extension unit or the GOT
8)	Rating plate	-

4. INSTALLATION PROCEDURE

The installation procedure for the MELSECNET/H communication unit is explained using the GT1575.

- (1) Power off the GOT.
- (2) Remove two extension unit covers of the GOT.

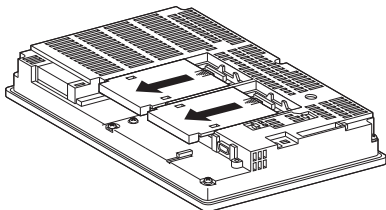

- (3) Attach the extend interface relay board to the extend I/F-2 side on the GOT.

After the installation, detach the connector cover from the extend interface relay board.

For GT155□, the extend interface relay board is not needed.

- (4) Fit the MELSECNET/H communication unit in the GOT case.

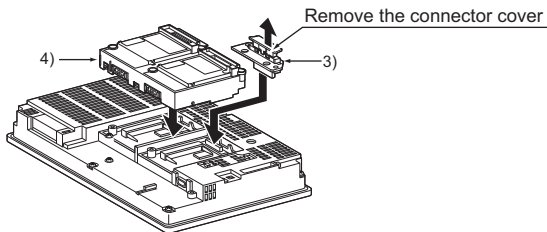

- (5) Fasten the MELSECNET/H communication unit by tightening its mounting screws (4 places) with tightening torque 0.36 to 0.48 N·m.

- (6) Fasten the bus connection unit by tightening the board fixing screws (2 places) with the tightening torque of 0.36 to 0.48 N•m.

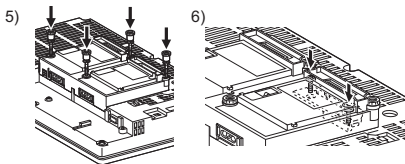

- (7) When installing an extension unit on the unit that has been installed, remove the connector cover and the sticker. When not installing an extension unit on the unit that has been installed, in order to avoid receiving electrostatic, stick accessory stickers to cover the top of mounting screws (4 places). Keep the connector cover fixed. Keep the sticker stuck as it is.

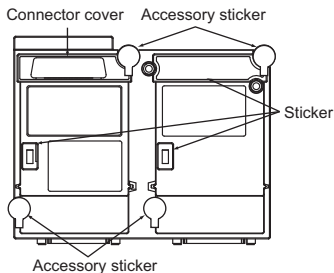

Point

Remove the screws that fixes the extend interface relay board before removing the unit.
(Above 6))

5. PRECAUTIONS FOR LAYING CABLES

5.1 Precautions for cable connection (GT15-J71LP23-25)

- (1) The distance between stations varies depending on the type of optical-fiber cable used.

Type		Distance between stations [m (ft.)]	
		25Mbps	10Mbps
SI optical fiber cable (Old type: A-2P-□)	L type	200 (656)	500 (1640)
	H type	100 (328)	300 (984)
SI optical fiber cable		200 (656)	500(1640)
H-PCF optical fiber cable		400 (1312)	1000(3281)
Broad-band H-PCF optical fiber cable		1000 (3281)	1000(3281)
QSI optical fiber cable		1000 (3281)	1000(3281)

- (2) When connecting an optical-fiber cable, the following restrictions on the bending radius must be observed.
For further details, contact Mitsubishi Electric System & Service Co.,Ltd.
- (3) When laying the optical-fiber cable, do not touch the fiber core of the cable connector or module connector, or let dirt or dust collect on it.
If oil from the hands, dirt or dust should adhere to the core, the transmission loss will increase, causing a malfunction in the data link.
Do not remove the covers from the unit connectors without optical-fiber cables connected.
- (4) When attaching or detaching the optical-fiber cable to/from the unit, hold the cable connector securely with the hands.
- (5) Connect the cable connector and unit connector securely until you hear a "click" sound.
- (6) For connecting or removing the optical-fiber cables, be sure to shut off all phases of the external power supplies used in the system.

(7) Please wire IN/OUT of the connector for the cable correctly.
After wiring, perform a loop test or station-to-station test or others to confirm if the setting and wiring of GT15-J71LP23-25 have been done properly.

For testing methods, refer to the following manuals.

- Type MELSECNET/10 Network system (PLC to PLC network)
Reference Manual
- For QnA/Q4AR MELSECNET/10 Network System
Reference Manual
- Q Corresponding MELSECNET/H Network System
Reference Manual (PLC to PLC network)

It might be generated that a baton abnormal passing cannot be generated when miswiring and the downed bureau which cannot do the loopback of an arbitrary bureau do the row again even by the reclosing of the power supply.

5.2 Precautions for cable connection (GT15-J71BR13)

(1) Restrictions on the cable length between stations

- (a) When connecting between the network modules, the cable lengths indicated in the table below should be used according to the number of stations connected.

A communication error may occur if a cable length other than the lengths indicated in the table is used.

Station-to-station cable length \ Number of stations connected	2 to 9 stations		10 to 32 stations	
	3C-2V	5C-2V	3C-2V	5C-2V
0 to 1 m (3.28 ft.)	× (cable less than 1 m (3.28 ft.) in length cannot be used.)			
1 (3.28 ft.) to 5 m (16.4 ft.)	○	○	○	○
5 (16.4 ft.) to 13 m (42.65 ft.)	○	○	×	×
13 (42.65 ft.) to 17 m (55.77 ft.)	○	○	○	○
17 (55.77 ft.) to 25 m (82.02 ft.)	○	○	×	×
25 (82.02 ft.) to 300 m (984.25 ft.)	○	○	○	○
300 (984.25 ft.) to 500 m (1640.42 ft.)	×	○	×	○

○ : Allowed × : Not allowed

- (b) If there is the possibility of an increase in the number of stations due to system expansion, install the cables with advance consideration of the restrictions.
- (c) When using a repeater module (models A6BR10 or A6BR10-DC), use the station-to-station cable length indicated by "10 to 32" stations, regardless of the number of stations connected or the number of repeater modules.
- (2) Precautions for laying cable

- (a) Coaxial cables must be laid 100mm (3.94 inches) or more apart from power cables and control cables.
- (b) Consider wiring using double-shielded coaxial cable in places that are subject to large amounts of noise.

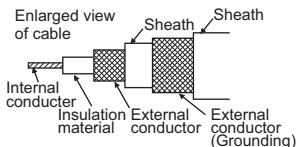
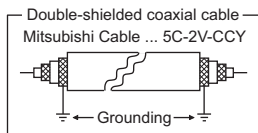

The 5C-2V connector plug is applicable to double-shielded coaxial cable.

Connect the 5C-2V connector plug to the coaxial cable inside a double-shielded coaxial cable. Ground the shielded part outside a double-shielded coaxial cable as shown in the above figure.

- (3) Double-shielded coaxial cables have the following restrictions on the bending radius.

Cable type	Allowable bending radius r [mm](in.)	Connector A[mm](in.)
3C-2V	23 (0.91)	57.5 (2.46)
5C-2V	30 (1.18)	

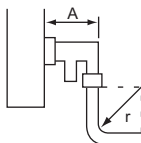

- (4) Do not pull any of the connected coaxial cables.
This will cause a faulty contact, cable disconnection, or damage to the unit.
- (5) Make sure to connect a terminal resistor to both terminal stations of the coaxial bus type network system.
- (6) The F type connector has the possibility to extract a white oxide according to the use environment.
However, there is no problem on the function because the oxide is not generated in connected part.
- (7) Please wire the cable correctly.
After wiring, perform a station-to-station test or others to confirm if the setting and wiring of GT15-J71BR13 have been done properly.
For testing methods, please refer to following manuals.
- Type MELSECNET/10 Network system (PLC to PLC network) Reference Manual
 - For QnA/Q4AR MELSECNET/10 Network System Reference Manual
 - Q Corresponding MELSECNET/H Network System Reference Manual (PLC to PLC network)
- It might be generated that a baton abnormal passing cannot be generated when miswiring and the downed bureau cannot do the row again even by the reclosing of the power supply.

6. WIRING METHOD

(1) GT15-J71LP23-25

The optical fiber cable is wired in the following manner.

There is no problem even if not wiring in order of the station number.

Define a control station number and a normal station number according to the system specifications.

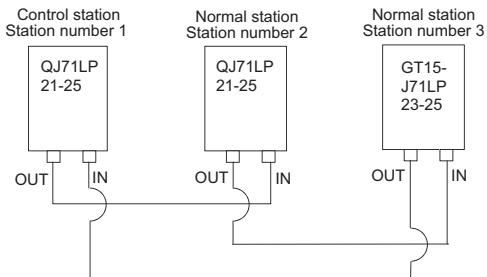

(2) GT15-J71LP23-25

The coaxial cable is wired in the following manner.

There is no program even if not wiring in order of the station number.

Define a control station number and a normal station number according to the system specifications.

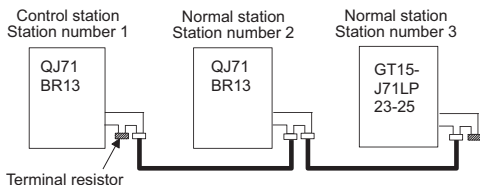

7. EXTERNAL DIMENSIONS

(1) GT15-J71LP23-25

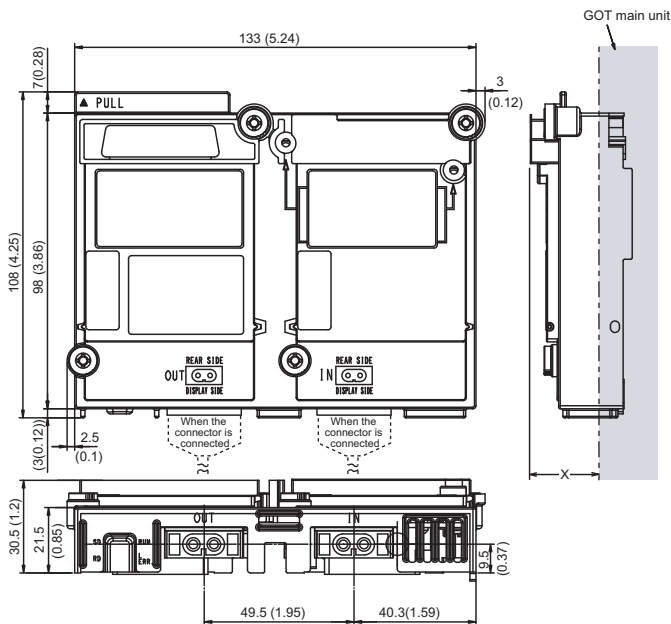

Dimensions of X when the MELSECNET/H communication unit is mounted to the GOT.

	GOT	GT16	GT15
15"		19.5 (0.77)	21 (0.83)
12.1"		18 (0.71)	18 (0.71)
10.4"		21 (0.83)	21 (0.83)
8.4"		23 (0.91)	23 (0.92)
5.7"		23 (0.91)	23 (0.92)

Unit:mm (inch)

*Please contact Mitsubishi Electric System & Service Co., Ltd.

(2) GT15-J71BR13

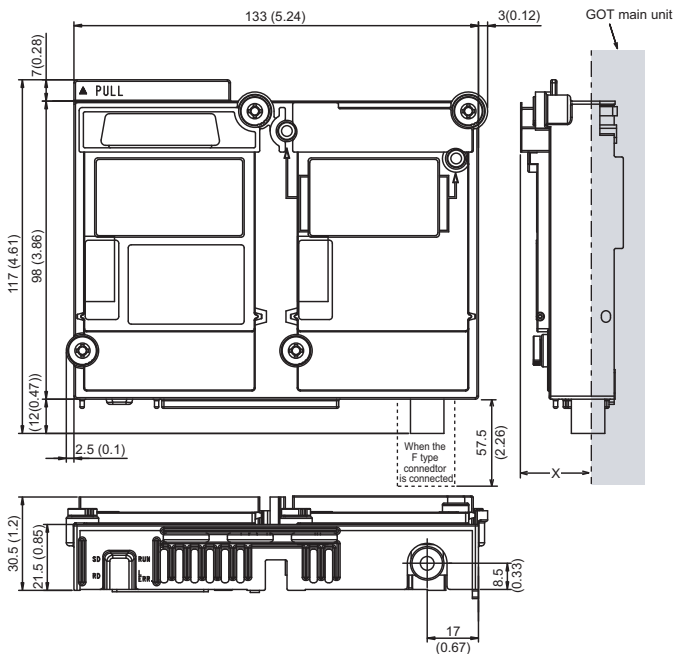

Dimensions of X when the MELSECNET/H communication unit is mounted to the GOT.

GOT	GT16	GT15
15"	19.5 (0.77)	21 (0.83)
12.1"	18 (0.71)	18 (0.71)
10.4"	21 (0.83)	21 (0.83)
8.4"	23 (0.91)	23 (0.92)
5.7"	23 (0.91)	23 (0.92)

Unit:mm (inch)

(3) Extend interface relay board

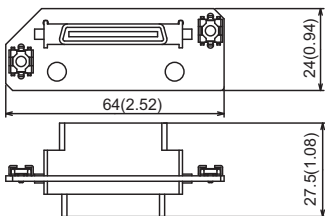

Unit:mm (inch)

Warranty

Mitsubishi will not be held liable for damage caused by factors found not to be the cause of Mitsubishi; machine damage or lost profits caused by faults in the Mitsubishi products; damage, secondary damage, accident compensation caused by special factors unpredictable by Mitsubishi; damages to products other than Mitsubishi products; and to other duties.

For safe use

- This product has been manufactured as a general-purpose part for general industries, and has not been designed or manufactured to be incorporated in a device or system used in purposes related to human life.
- Before using the product for special purposes such as nuclear power, electric power, aerospace, medicine or passenger movement vehicles, consult with Mitsubishi.
- This product has been manufactured under strict quality control. However, when installing the product where major accidents or losses could occur if the product fails, install appropriate backup or failsafe functions in the system.

Country/Region	Sales office/Tel	Country/Region	Sales office/Tel
U.S.A	Mitsubishi Electric Automation Inc. 500 Corporate Woods Parkway Vernon Hills, IL 60061, U.S.A. Tel : +1-847-478-2100	Hong Kong	Mitsubishi Electric Automation (Hong Kong) Ltd. 10th Floor, Manulife Tower, 169 Electric Road, North Point, Hong Kong Tel : +852-2887-8870
Brazil	MELCO-TEC Rep. Com.e Assessoria Tecnica Ltda. Rua Correia Dias, 184, Edificio Paraiso Trade Center-8 andar Paraiso, Sao Paulo, SP Brazil Tel : +55-11-5908-8331	China	Mitsubishi Electric Automation (China) Ltd. 4/F Zhi Fu Plaza, No.80 Xin Chang Road, Shanghai 200003, China Tel : +86-21-6120-0808
Germany	Mitsubishi Electric Europe B.V. German Branch Gothaer Strasse 8 D-40880 Ratingen, GERMANY Tel : +49-2102-486-0	Taiwan	Setsuyo Enterprise Co., Ltd. 6F No.105 Wu-Kung 3rd.Rd, Wu-Ku Hsiang, Taipei Hsine, Taiwan Tel : +886-2-2299-2499
U.K	Mitsubishi Electric Europe B.V. UK Branch Travellers Lane, Hatfield, Hertfordshire., AL10 8XB, U.K. Tel : +44-1707-276100	Korea	Mitsubishi Electric Automation Korea Co., Ltd. 1480-6, Gayang-dong, Gangseo-ku Seoul 157-200, Korea Tel : +82-2-3660-9552
Italy	Mitsubishi Electric Europe B.V. Italian Branch Centro Dir. Colleoni, Pal. Perseo-Ingr.2 Via Paracelso 12, I-20041 Agrate Brianza., Milano, Italy Tel : +39-039-60531	Singapore	Mitsubishi Electric Asia Pte, Ltd. 307 Alexandra Road #05-01/02, Mitsubishi Electric Building, Singapore 159943 Tel : +65-6470-2460
Spain	Mitsubishi Electric Europe B.V. Spanish Branch Carretera de Rubi 76-80, E-08190 Sant Cugat del Valles, Barcelona, Spain Tel : +34-93-565-3131	Thailand	Mitsubishi Electric Automation (Thailand) Co., Ltd. Bang-Chan Industrial Estate No.111 Moo 4, Serithai Rd, T.Kannayao, A.Kannayao, Bangkok 10230 Thailand Tel : +66-2-517-1326
France	Mitsubishi Electric Europe B.V. French Branch 25, Boulevard des Bouvets, F-92741 Nanterre Cedex, France Tel : +33-1-5568-5568	Indonesia	P.T. Autoteknindo Sumber Makmur Muara Karang Selatan, Block A/Utara No.1 Kav. No.11 Kawasan Industri Pergudangan Jakarta - Utara 14440, P.O.Box 5045 Jakarta, 11050 Indonesia Tel : +62-21-6630833
South Africa	Circuit Breaker Industries Ltd. Private Bag 2016, ZA-1600 Isando, South Africa Tel : +27-11-928-2000	India	Messung Systems Pvt, Ltd. Electronic Sadan NO:III Unit No15, M.I.D.C Bhosari, Pune-411026, India Tel : +91-20-2712-3130
		Australia	Mitsubishi Electric Australia Pty. Ltd. 348 Victoria Road, Rydalmere, N.S.W 2116, Australia Tel : +61-2-9684-7777

MITSUBISHI ELECTRIC CORPORATION

HEAD OFFICE : TOKYO BUILDING, 2-7-3 MARUNOUCHI, CHYODAI-KU, TOKYO 100-8310, JAPAN
NAGOYA WORKS : 1-14, YADA-MINAMI 5-CHOME, HIGASHI-KU, NAGOYA, JAPAN

When exported from Japan, this manual does not require application to the Ministry of Economy, Trade and Industry for service transaction permission.

Specifications subject to change without notice.
Printed in Japan, June 2011.