

Basic device – SNO 4003K

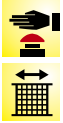

Applications

- Protection of people and machinery
- Monitoring of emergency stop applications
- Monitoring of safety gates
- Up to PL d/Category 2 (EN ISO 13849-1)*
- Up to SIL_{CL} 2 (EN 62061)*

Features

- Stop Category 0 according to EN 60204-1
- Single-channel or two-channel control
- Manual or automatic start
- 3 enabling current paths, 1 signaling current path
- Feedback loop for monitoring external contactors

* Specific applications may also require higher categories/levels

Function

The device is a single-channel switching device for emergency stop applications with self-monitoring on each ON-OFF cycle. It complies with EN 60204-1 and is equipped with forcibly guided relays.

The device has either two Y2 reset inputs (without reset monitoring) or two Y3 reset inputs (with reset monitoring). The K1 and K2 relays are actuated either automatically (bridge Y1 Y2) or after the reset button (on Y1 Y3) has been pressed.

They become self-locking through their own contacts, if there is an electrical connection between terminal A1 and the supply voltage (emergency stop button, position switches).

After this switch-on phase the enabling current paths are closed and the signaling current path is open.

If the electrical connections between terminal A1 and the supply voltage are interrupted, the enabling current paths open and the signaling current path closes. The energized state (self-locking) of the two channels is indicated by a green LED K1, K2. The second green LED indicates that supply voltage has been applied. The set-up of an emergency stop facility after stop Category 0 (EN 60204-1) is possible. The device corresponds to PL e/Category 4 for safety-related parts of controls (EN 13849-1).

Circuit diagram

SNO 4003K

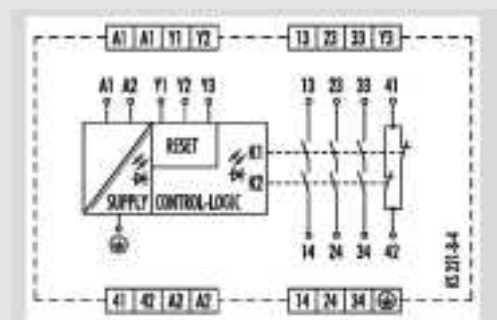
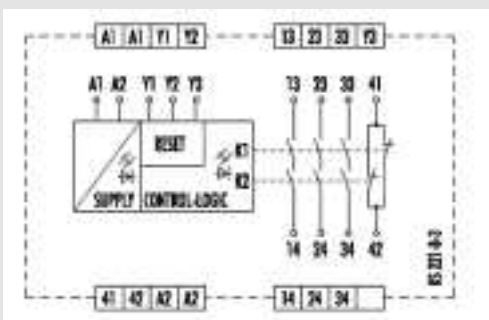

Basic device – SNO 4003K

Overview of devices | part numbers

Type	Rated voltage	Terminals	Part no.	Std. pack
SNO 4003K	24 V AC/DC	Screw terminals, fixed	R1.188.0400.1	1
	115 – 120 V AC	Screw terminals, fixed	R1.188.0880.1	1
	230 V AC	Screw terminals, fixed	R1.188.0890.1	1
SNO 4003K-A	24 V AC/DC	Screw terminals, pluggable	R1.188.0500.1	1
	115 – 120 V AC	Screw terminals, pluggable	R1.188.0900.1	1
	230 V AC	Screw terminals, pluggable	R1.188.0910.1	1
SNO 4003K-C	24 V AC/DC	Cage clamp, pluggable	R1.188.1990.0	1

Technical data

Function	Emergency stop relay		
Function display	2 LEDs, green		
Power supply circuit			
Rated voltage U_N	A1, A2	24 V AC/DC / 115-120 V AC / 230 V AC	
Rated consumption	24 V DC	1.3 W	
	115-120 V AC, 230 V AC	2.2 W / 3.9 VA	
Rated frequency	50 - 60 Hz		
Operating voltage range U_B	0.85 - 1.1 x U_N		
Electrical isolation supply circuit - control circuit	yes (at $U_N = 115-120$ V AC, 230 V AC)		
Control circuit			
Rated output voltage	Y1	24 V DC	
Input current / peak current	Y2, Y3	90 mA / 1500 mA	
Response time t_{A1} / t_{A2}	60 ms		
Minimum ON time t_M (Manueller Start)	60 ms		
Recovery time t_w	200 ms		
Release time t_R	60 ms		
Max. resistivity	24V AC/DC	$\leq (2.5 + (1.176 \times U_B / U_N - 1) \times 50) \Omega$	
	115-120 V AC, 230 V AC	$\leq (7.5 + (1.176 \times U_B / U_N - 1) \times 150) \Omega$	
Output circuit			
Enabling paths	13/14, 23/24, 33/34		
Signaling paths	41/42	normally closed contact	
Contact assignment	forcebly guided		
Contact type	Ag-alloy, gold-plated		
Rated switching voltage	enabling / signaling path	230 V AC	
Max. thermal current I_{th}	enabling / signaling path	8 A / 5 A	
Max. total current I^2 of all current path	($T_u = 55$ °C)	9 A ²	
Application category (NO)	AC-15	U_e 230 V, I_e 5 A	
	DC-13	U_e 24 V, I_e 5A	
Short-circuit protection (NO), lead fuse / circuit breaker	6 A class gG / melting integral < 100 A ² s		
Mechanical life	10 ⁷ switching cycles		
General data			
Creepage distances and clearances between the circuits	EN 60664-1		
Protection degree according to DIN EN 60529 (housing / terminals)	IP40 / IP20		
Ambient temperature / storage temperature	-25 °C - +55 °C / -25 °C - + 75 °C		
Wire ranges screw terminals,	fine-stranded / solid	1 x 0.14 mm ² – 2.5 mm ² / 2 x 0.14 mm ² – 0.75 mm ²	
	fine-stranded with ferrules	1 x 0.25 mm ² – 2.5 mm ² / 2 x 0.25 mm ² – 0.5 mm ²	
Permissible torque	0.5 - 0.6 Nm		
Wire ranges cage clamp terminals	1 x 0.25 mm ² – 1.5 mm ²		
Weight	24 V AC/DC device / AC device	0.20 kg / 0.25 kg	
Standards	EN ISO 13849-1, EN 62061		
Approvals	