



FUSOMAT

Visible breaking and tripping fuse switches
from 250 to 1250 A

Fuse protection



fusom_063_b_1_cat

The solution for

- > Motor load break.
- > Protection of industrial cabinet.
- > Electrical distribution.



Strong points

- > Tripping upon overload.
- > High breaking capacity.
- > Improved safety.

A complete range

- > Can be combined with UR fuses for the protection of power semi-conductors - Please consult us.

Conformity to standards

- > IEC 60947-3
- > EN 60947-3
- > VDE 0660-107
- > NBN EN 60947-3
- > BS 88



Function

FUSOMAT are manually controlled tri- or tetrapolar fuse combination switches.

They can be tripped remotely.

They break or switch off on load and provide safety isolation and protection against overcurrent for any low voltage electrical circuit.

They can automatically disconnect a circuit in combination with:

- fuse blown indication.
- thermal relay.
- protective relays DIRIS.
- other protective devices.

Advantages

Tripping upon overload

Remote breaking by voltage release device.

High breaking capacity

Protection against overloads and short-circuits thanks to high breaking capacity fuses (100 kA rms).

Improved safety

- Double break per phase (top and bottom of fuse - up to 630 A (NFC/DIN) and 800 A (BS88).
- Positive break indication.
- IP2X protection with terminal shrouds front panel.

Configurations

Functional diagram (for further details see the installation instructions supplied with the product).

1. Direct front operation.
2. External front operation.
3. NO/NC position AC.
4. NO/NC AC wired to ready mounted transmission coil.
5. Terminal shrouds.
6. Fuse blown indication device.

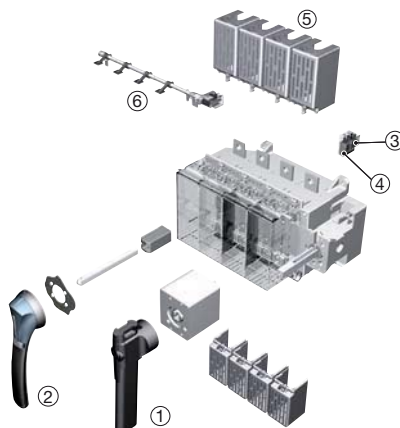

fusom_060_b_1_x_cat

References

BS88 - Front and side operation - Switch body with a shunt trip coil - 230 VAC

Rating (A) Fuse ⁽¹⁾	No. of poles	Front operation Switch body	Side operation Switch body	Direct handle ⁽²⁾	External handle	Shaft for external handle	Auxiliary contact position	Auxiliary contact tripping	Terminal shrouds ⁽³⁾	Terminal screens ⁽⁴⁾	Inter phase barrier
250 A B1-B2-B3	3 P	3660 3026	3665 3026	Front operation Black 3999 6012					3 P 3998 3040		
	4 P	3660 6026	3665 6026								
400 A B1-B2-B3-B4	3 P	3660 3041	3665 3041	Side operation Black 3999 6012	S3 type				4 P 3998 4040		
	4 P	3660 6041	3665 6041								
630 A C1-C2	3 P	3660 3064	3665 3064	Front operation Black IP55 1431 3511 ⁽²⁾ Red IP55 1432 3511		Front operation 200 mm 1401 1520 320 mm 1401 1532 ⁽²⁾	1 st contact NO/NC 3999 0051	1 contact NO/NC 3999 0031	3998 3063		
	4 P	3660 6064	3665 6064								
800 A C1-C2-C3	3 P	3660 3080	3665 3080	Front operation Black 3999 6012	Side operation Black IP55 1435 3511 ⁽²⁾ Red IP55 1436 3511	Side operation 200 mm 1403 1520					
	4 P	3660 6080	3665 6080								
1250 A D1	3 P	3660 3121	3665 3121	Side operation Black 3999 6012						3 P 3998 3120 4 P 3998 4120	3 P 2998 0003 4 P 2998 0004
	4 P	3660 6121	3665 6121								

(1) For the fuses: see page 230 "BS88 industrial fuselinks".

(2) Standard.

(3) Top/bottom.

(4) Bottom terminals protection screen as standard.

FUSOMAT

Visible breaking and tripping fuse switches
from 250 to 1250 A

References

NFC and DIN - Front operation - Switch body with a shunt trip coil - 230 VAC

Rating (A) Fuse	No. of poles	Switch body	Direct handle	External handle	Shaft for external handle	Auxiliary contact position	Auxiliary contact tripping	1 st Fuse blown AC	Terminal shrouds (1 piece)	Terminal screens top	Inter phase barrier										
250 A / 1	3 P	3650 3026	Black 3999 6201 ⁽¹⁾	S3 type Black IP55 1431 3511 ⁽¹⁾	200 mm 1401 1520	1 st contact NO/NC 3999 0051	1 contact NO/NC 3999 0031	3 P 3994 1304	3 P 3998 3040 ⁽²⁾												
	4 P	3650 6026																			
400 A / 2	3 P	3650 3041																			
	4 P	3650 6041																			
630 A / 3	3 P	3650 3064										S3 type Red/yellow IP55 1432 3511	320 mm 1401 1532 ⁽¹⁾	2 nd contact NO/NC 3999 0052			3 P 3994 1306	3 P 3998 3063 ⁽²⁾			
	4 P	3650 6064																			
800 A / 4	3 P	3650 3080																			
	4 P	3650 6080																			
1250 A / 4	3 P	3650 3121		Black 3999 6012 ⁽¹⁾					3 P 3994 1312	3 P 3998 3120 ⁽³⁾	3 P 2998 0003										
	4 P	3650 6121																			
	3 P																				
	4 P																				
	3 P																				
	4 P																				

(1) Standard.

(2) Top/bottom.

(3) Bottom terminals protection screen as standard.

NFC and DIN - Side operation - Switch body with a shunt trip coil - 230 VAC

Rating (A) Fuse	No. of poles	Switch body	Direct handle	External handle	Shaft for external handle	Auxiliary contact position	Auxiliary contact tripping	1 st Fuse blown AC	Terminal shrouds (1 piece)	Terminal screens top	Inter phase barrier					
250 A / 1	3 P	3655 3026	Black 3999 6012 ⁽¹⁾	S3 type Black IP55 1435 3511 ⁽¹⁾ S3 type Red IP55 1436 3511	200 mm 1403 1520	1 st contact NO/NC 3999 0051 2 nd contact NO/NC 3999 0052	1 contact NO/NC 3999 0031	3 P 3994 1304	3 P 3998 3040 ⁽²⁾							
	4 P	3655 6026														
400 A / 2	3 P	3655 3041											4 P 3994 1404	4 P 3998 4040 ⁽²⁾		
	4 P	3655 6041														
630 A / 3	3 P	3655 3064											3994 1306	3998 3063 ⁽²⁾		
	4 P	3655 6064											3994 1406	3998 4063 ⁽²⁾		
800 A / 4	3 P	3655 3080														
	4 P	3655 6080											3 P 3994 1312		3 P 3998 3120 ⁽³⁾	3 P 2998 0003
1250 A / 4	3 P	3655 3121											4 P 3994 1412		4 P 3998 4120 ⁽³⁾	4 P 2998 0004
	4 P	3655 6121														

(1) Standard.

(2) Top/bottom.

(3) Bottom terminals protection screen as standard.

FUSOMAT

Visible breaking and tripping fuse switches
from 250 to 1250 A

Accessories

Direct handle

Front operation		
Rating (A)	Handle colour	Reference
250 ... 630	Black	3999 6201
800 ... 1250	Black	3999 6012
250 ... 1250	Red	consult us

Side operation		
Rating (A)	Handle colour	Reference
250 ... 1250	Black	3999 6012
250 ... 1250	Red	3999 6013



access_156_a_2_cat

External handle

Front operation				
Rating (A)	Handle type	Handle colour	External IP	Reference
250 ... 1250	S3	Black	IP55	1431 3511
250 ... 1250	S3	Red	IP55	1432 3511

Side operation				
Rating (A)	Handle type	Handle colour	External IP	Reference
250 ... 1250	S3	Black	IP55	1435 3511
250 ... 1250	S3	Red	IP55	1436 3511



access_151_a_1_cat



access_156_a_2_cat

S3 type handle

S3 type handle

S-type handle adapter

Use

Enables S-type handles to be fitted in place of existing older style Socomec handles.

Dimensions

Adds 12 mm to the depth.

Handle colour	To be ordered in multiples of	External IP ⁽¹⁾	Reference
Black	1	IP65	1493 0000

(1) IP: protection degree according to IEC 60529 standard.



access_157_a_1_cat

Alternative S-type handle cover colours

Use

For single lever S3 type handles.

Other colours: Please consult us.

Colour	To be ordered in multiples of	Handle	Reference
Light grey	50	S3 type	1401 0001
Dark grey	50	S3 type	1401 0011
Light grey	50	S4 type	1401 0031
Dark grey	50	S4 type	1401 0041



access_158_a_2_cat

Shaft for external handle

Use

Standard lengths:

- 200 mm
- 320 mm.

Other lengths: Please consult us.

Front operation				
Rating (A)	Dimension X (mm)	Shaft length (mm)	Type	Reference
250 ... 400	300 ... 422	200	15 x 12	1401 1520
250 ... 400	300 ... 542	320	15 x 12	1401 1532
630 ... 1250	345 ... 467	200	15 x 12	1401 1520
630 ... 1250	345 ... 587	320	15 x 12	1401 1532

Side operation				
Rating (A)	Dimension Y (mm)	Shaft length (mm)	Type	Reference
250 ... 1250	78 ... 200	200	15 x 12	1403 1520



access_144_b_1_1_cat

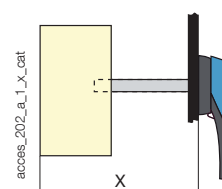

access_202_a_1_x_cat

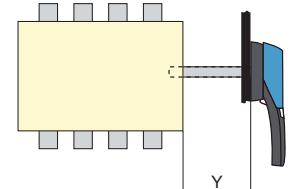

access_202_a_1_y_cat

Auxiliary contact

Use

Pre-break and signalling of positions 0 and I:
1 to 2 NO/NC auxiliary contacts.

Coil tripping

1 to 2 NO/NC auxiliary contacts.

Connection to the control circuit

By 6.35 mm fast-on terminal.

Characteristics

Auxiliary contact NO/NC IP2.

Electrical characteristics

30 000 operations.

NO/NC position contact

Rating (A)	Current nominal (A)	Operating current I _o (A)			
		250 VAC AC-13	400 VAC AC-13	24 VDC DC-13	48 VDC DC-13
250 ... 1250	16	12	8	14	6

NO/NC contact signalling coil tripping

Rating (A)	Current nominal (A)	Operating current I _o (A)			
		250 VAC AC-13	400 VAC AC-13	24 VDC DC-13	48 VDC DC-13
250 ... 1250	16	12	8	12	2

NO/NC position contact

Rating (A)	Position AC	Reference
250 ... 1250	1 st AC	3999 0051
250 ... 1250	2 nd AC	3999 0052
630 ... 1250	3 rd and more	consult us

NO/NC low level position contact

Rating (A)	Position AC	Reference
250 ... 1250	1 st AC	3999 0111
250 ... 1250	2 nd AC	3999 0112

NO/NC contact signalling coil tripping

Rating (A)	Position AC	Reference
250 ... 1250	1 AC	3999 0031

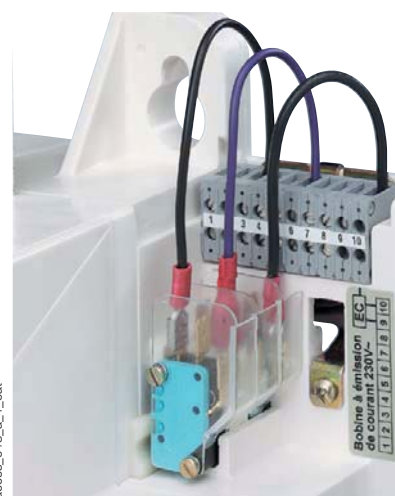

acces_04B_a_1_cat

Alternative tripping coil

Shunt trip coil

Voltage	Replacement tripping coil	Modified Original coil
	Reference	Reference
24 VAC	3990 1024	3991 1024
48 VAC	3990 1048	3991 1048
110 VAC	3990 1110	3991 1110
230 VAC	3990 1220	included
400 VAC	3990 1380	3991 1380
12 VDC	3990 2012	3991 2012
24 VDC	3990 2024	3991 2024
48 VDC	3990 2048	3991 2048
110 / 200 VDC	3990 2220	3991 2220
220 VDC	3990 2220	

Undervoltage trip coil

Voltage	Replacement tripping coil	Modified Original coil
	Reference	Reference
24 VAC	3990 3024	3991 3024
48 VAC	3990 3048	3991 3048
110 VAC	3990 3110	3991 3110
230 VAC	3990 3220	3991 3220
400 VAC	3990 3380	3991 3380
12 VDC	3990 4012	3991 4012
24 VDC	3990 4024	3991 4024
48 VDC	3990 4048	3991 4048
110 VDC	3990 4110	3991 4110
220 VDC	3990 4220	3991 4220

Delayed undervoltage trip coil

Voltage	Reference
230 VAC	3992 3230
400 VAC	3992 3400

Use

Omnipolar breaking remotely controlled by shunt trip or undervoltage voltage release coil.

Note: the shunt trip coil must not be supplied for more than 5 s.

A 230 VAC shunt trip coil is fitted to the standard switch body. To modify this coil, the reference opposite must be added to the switch reference.

Examples for ordering:

- FUSOMAT with shunt trip coil 230 VAC - 1 reference: FUSOMAT 250 A, 3 pole, front operation, reference 3650 3026.
- FUSOMAT fitted with a non standard coil - 2 references: FUSOMAT 250 A, 3 pole, front operation, fitted with a 110 VAC undervoltage trip coil: 3650 3026 + 3991 3110.



Shunt trip coil

acces_049_a_1_cat



acces_050_a_1_cat

FUSOMAT

Visible breaking and tripping fuse switches
from 250 to 1250 A

Accessories (continued)

Current-reducing resistor for undervoltage trip coil

Use

Reduces, by limiting the current, the effects on the undervoltage coils used in continuous processes or processes exposed to high ambient temperatures.

Voltage	Reference
110 VAC	3999 3112
230 VAC	3999 3230
400 VAC	3999 3400
110 VDC	3999 4110

Fuse blown indication

Use

For DIN fuse cartridge with striker.

Electrical principle

A NO/NC auxiliary contact detects that the fuse has blown.

Connection to the control circuit

By 6.35 mm fast-on terminal.

Electrical characteristics

30 000 operations.

Characteristics

Rating (A)	Current nominal (A)	Operating current I _o (A)			
		250 VAC AC-13	400 VAC AC-13	24 VDC DC-13	48 VDC DC-13
250 ... 1250	16	12	8	12	2

NO/NC changeover contact

Rating (A)	No. of poles	Position AC	Reference
250 ... 400	3 P	1 st	3994 1304
250 ... 400	4 P	1 st	3994 1404
630	3 P	1 st	3994 1306
630	4 P	1 st	3994 1406
800 ... 1250	3 P	1 st	3994 1312
800 ... 1250	4 P	1 st	3994 1412
250 ... 1250	3/4 P	2 nd	3994 1902

Terminal shrouds

Use

Top or bottom protection against direct contact with terminals or connection parts.

Advantage

Perforations allowing remote thermographic inspection without removal.

Rating (A)	No. of poles	Position	Reference
250 ... 400	3 P	top or bottom	3998 3040 ⁽¹⁾
250 ... 400	4 P	top or bottom	3998 4040 ⁽²⁾
630	3 P	top or bottom	3998 3063 ⁽¹⁾
630	4 P	top or bottom	3998 4063 ⁽²⁾

(1) Reference composed of 3 pieces.

(2) Reference composed of 4 pieces.



access_213_b_1_cat

Terminal screen

Use

Top or bottom protection against direct contact with terminals or connecting parts.

Rating (A)	No. of poles	Position	Reference
800 ... 1250	3 P	top	3998 3120
800 ... 1250	4 P	top	3998 4120
800 ... 1250	3/4 P	bottom	included



fusom_069_a_1_cat

Cage terminals

Use

Connection of bare copper cables onto the terminals (without lugs).

References

Rating max (A)	No. of poles	Reference
250	3 P	5400 3025
250	4 P	5400 4025
400	3 P	5400 3040
400	4 P	5400 4040
500 ... 630	3 P	5400 3063
500 ... 630	4 P	5400 4063



access_053_a_1_cat

Connections

Rating (A)	Flexible cable cross-section (mm ²)	Rigid cable cross-section (mm ²)	Width flexible bar (mm)	Stripped over (mm)
250	16 ... 185	16 ... 185	18	27
400	50 ... 240	50 ... 300	20	34
500 ... 630	70 ... 300	70 ... 300	24	34

Dimensions

Rating (A)	A	A1	C	R	ØX	X1	Z
250	62	31.5	31.5	25	10.5	M16	14
400	71.5	32	38	32	10.5	M20	15
500 ... 630	76.5	37	38	40	12.5	M20	15

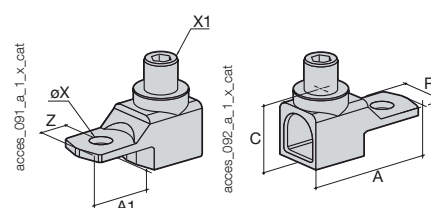

access_091_a_1_x_cat

access_092_a_1_x_cat

Handle key interlocking accessories

Use

- Locking in position 0 of the front or side operation handle;
- using a padlock (not supplied) and factory integrated into the handle.
- using RONIS 1104 A lock (key BC 3318) to be mounted directly on the padlockable handle.
- Locking using CASTELL K (not supplied)
- Locking using RONIS EL11AP (not supplied).

Locking using RONIS EL 1104 A lock (supplied)

Rating (A)	Operation	Reference
250 ... 1800	front direct	3999 8104

Locking using RONIS EL11AP lock (not supplied)

Rating (A)	Operation	Reference
250 ... 1800	external	1499 7701
1600 ... 1800	front direct	3999 6117

Locking using CASTELL lock (not supplied)

Rating (A)	Operation	Reference
250 ... 1250	external	1499 7702

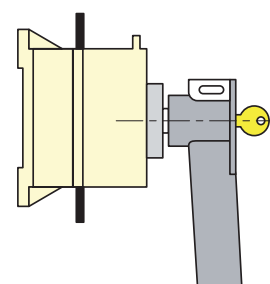

Lock RONIS 1104 A

access_010_b_1_x_cat

Label holder

Use

Recognisable self-adhesive label allowing identification of the devices.

Dimensions W x H (mm)	To be ordered in multiples of	Reference
18 x 13	50	7769 9999



access_044_a_1_cat

Other specific accessories

Use

- Customised protection screens (for specific dimensions or high ambient temperatures).
- Connection accessories.
- Mounting plates for standard systems.
- Special construction available for specific environments.

Characteristics according to IEC 60947-3

25 to 1250 A

Thermal current I_{th} (40°C)	250 A	400 A	630 A	800 A	1250 A
NFC/DIN fuse size	1	2	3	4	4
Rated insulation voltage U_i (V)	1000	1000	1000	1000	1000
Rated impulse withstand voltage U_{imp} (kV)	12	12	12	12	12

Rated operational currents I_e (A)

Rated voltage	Utilisation category	A/B ⁽¹⁾	A/B ⁽¹⁾	A/B ⁽¹⁾	A/B ⁽¹⁾	A/B ⁽¹⁾
400 VAC	AC-21 A / AC-21 B	250/250	400/400	630/630	800/800	1250/1250
400 VAC	AC-22 A / AC-22 B	250/250	400/400	630/630	800/800	1250/1250
400 VAC	AC-23 A / AC-23 B	250/250	400/400	630/630	800/800	1000/1000
690 VAC ⁽²⁾	AC-21 A / AC-21 B	200/200	315/400	500/630	800/800	800/1250
690 VAC ⁽²⁾	AC-22 A / AC-22 B	200/200	315/400	500/630	800/800	800/1000
690 VAC ⁽²⁾	AC-23 A / AC-23 B	200/200	250/315	315/400	630/630	630/630
220 VDC	DC-21 A / DC-21 B	200/200	315/315	400/630	800/800	800/1250
220 VDC	DC-22 A / DC-22 B	200/200	315/315	315/630	800/800	800/1250
220 VDC	DC-23 A / DC-23 B	200/200	200/315	400/630	800/800	800/1000
440 VDC	DC-21 A / DC-21 B	200/200	315/315	400/630 ⁽³⁾	800/800 ⁽⁴⁾	800/1250 ⁽⁴⁾
440 VDC	DC-22 A / DC-22 B	200/200	315/315 ⁽³⁾	315/630 ⁽³⁾	800/800 ⁽⁴⁾	800/1250 ⁽⁴⁾
440 VDC	DC-23 A / DC-23 B	200/200	200/315 ⁽³⁾	400/630 ⁽³⁾	800/800 ⁽⁴⁾	800/1000 ⁽⁴⁾

Operational power in AC-23 (kW)

At 400 VAC without pre-break in AC-23 (kW) ⁽¹⁾⁽⁵⁾	132/132	220/220	355/355	450/450	560/560
At 690 VAC without pre-break in AC-23 (kW) ⁽¹⁾⁽⁵⁾	185/185	220/295	295/400	400/400	600/600

Reactive power (kvar)

At 400 VAC (kvar) ⁽⁵⁾	115	185	290	365	575
----------------------------------	-----	-----	-----	-----	-----

Fuse protected short-circuit withstand (kA ms prospective)

Prospective short-circuit (kA rms) ⁽⁶⁾	80/100	80/100	80/100	80/100	80/100
Associated fuse rating (A) ⁽⁶⁾	250	400	630	800	1250

Short-circuit capacity

Rated peak withstand current (kA peak) ⁽⁶⁾	30	45	60	80	80
-------------------------------------------------------	----	----	----	----	----

Connection

Min. connection wire range	95	185	2 x 150		
Minimum Cu busbar section (mm ²)			2 x 30 x 5	2 x 60 x 5	2 x 60 x 5
Maximum Cu cable section (mm ²)	240	240	2 x 300	4 x 185	4 x 185
Maximum Cu busbar width (mm)	40	40	50	100	100
Tightening torque min (Nm)	20	20	40		20

Mechanical characteristics

Durability (number of operating cycles)	8000	8000	5000	5000	5000
Weight of a 3 pole device (kg)	7	8	16	28	28
Weight of a 4 pole device (kg)	8.5	9.5	19	33	33

(1) Category with index A = frequent operation - Category with index B = infrequent operation.

(2) With terminal shrouds or phase barrier.

(3) Poles cannot be juxtaposed.

(4) 4-pole device with 2 pole in series by polarity.

(5) The power value is given for information only, the current values vary from one manufacturer to another.

(6) For a rated operational voltage $U_o = 400$ VAC.

Dimensions

Front operation

BS88 - FUSOMAT 250 to 800 A

NFC and DIN - FUSOMAT 250 to 630 A

Direct front operation

External front operation

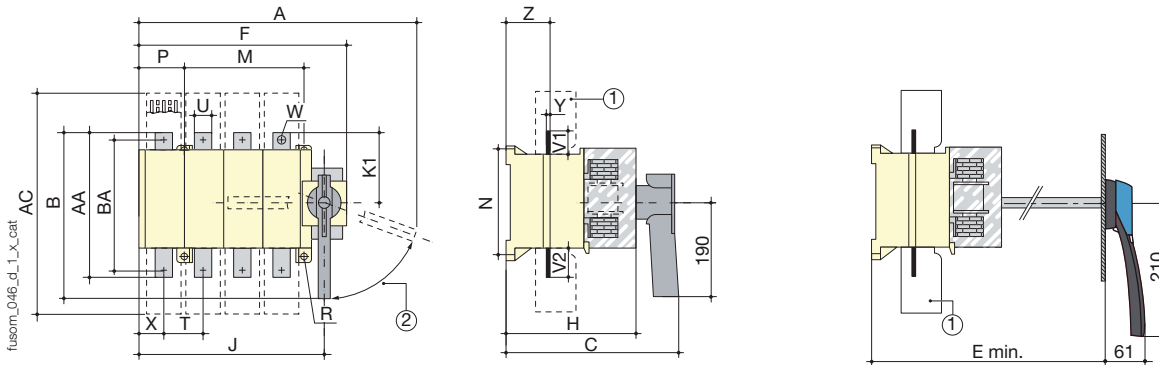

1. Terminal shrouds.
2. Reset 70°.

Rating (A)	Dimensions					Terminal shrouds	Switch body					Switch mounting					Connection											
	A 3p.	A 4p.	B	C	E		AC	F 3p.	F 4p.	H	J 3p.	J 4p.	K1	M	N	P 3p.	P 4p.	R	T	U	V1	V2	W	X 3p.	X 4p.	Y	Z	AA
250	435	495	305	307	297 ... 343	380	285	345	221	253	313	115	210	180	10	70	7	65	32	35	43	11	31	46	3	67	238	208
400	435	495	305	307	293 ... 343	380	285	345	221	253	313	115	210	180	10	70	7	65	32	35	43	13	31	46	5	69	238	208
630	490,5	570,5	350	348	341 ... 440	470	345,5	425,5	268	308	388	150	250	250	20	100	9	80	50	50	50	13	36	65	7	72	300	260
800	490,5	570,5	350	348	341 ... 440	470	345,5	425,5	268	308	388	150	250	250	20	100	9	80	50	50	50	13	36	65	7	72	300	-

BS88 - FUSOMAT 1250 A

NFC and DIN - FUSOMAT 800 to 1250 A

Direct front operation

External front operation

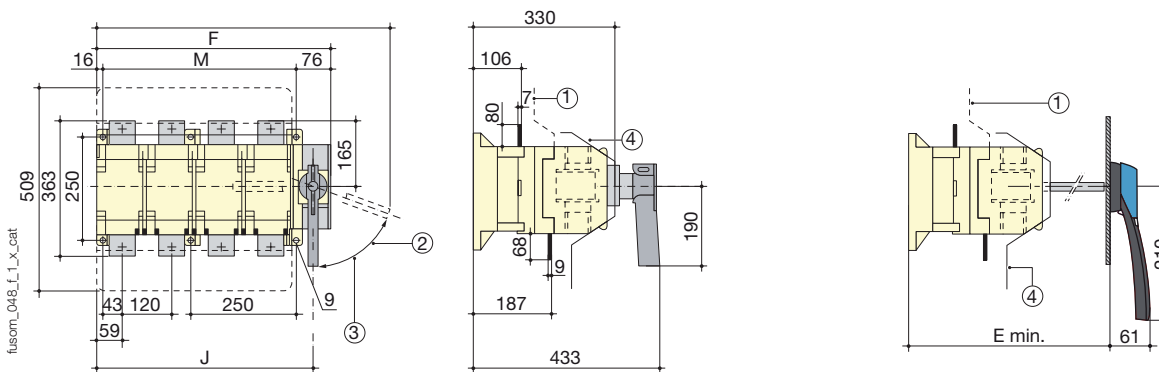

1. Top terminal screens
2. Reset 70°.
3. Padlocking 65°.
4. Front terminal screens

Rating (A)	Overall dimensions			Switch body				Switch mounting	
	A 3p.	A 4p.	E min	F 3p.	F 4p.	J 3p.	J 4p.	M 3p.	M 4p.
800 ⁽¹⁾	582	702	345	437	557	399,5	519,5	345	465
1250	582	702	345	437	557	399,5	519,5	345	465

(1) NFC and DIN only.