

OPERATING INSTRUCTIONS

C4000 Micro, C4000 Basic Plus,
C4000 Basic, C4000 Eco

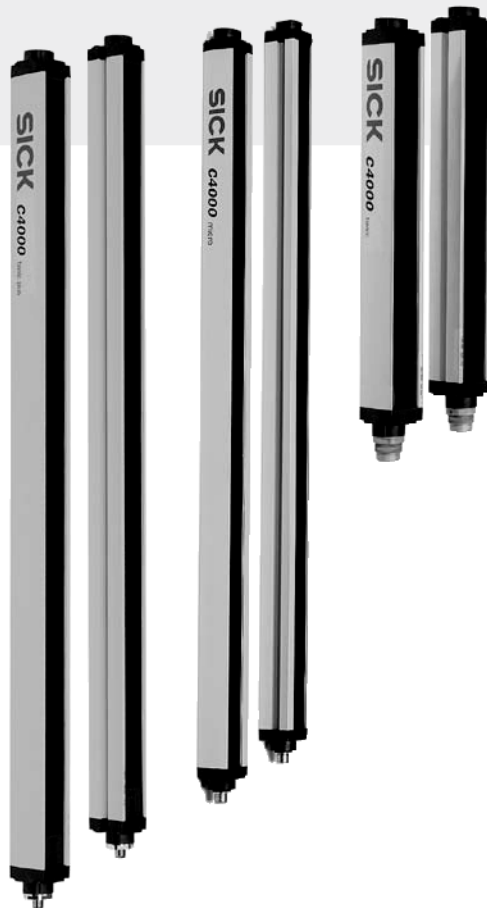

Safety light curtain



GB

SICK
Sensor Intelligence.

This document is protected by the law of copyright, whereby all rights established therein remain with the company SICK AG. Reproduction of this document or parts of this document is only permissible within the limits of the legal determination of Copyright Law. Alteration or abridgement of the document is not permitted without the explicit written approval of the company SICK AG.



Update**WARNING****Please take note of the following updates to this document!**

Based on Machinery Directive 2006/42/EC, we have added the following supplementary data or change notices on our product to the following document.

Scope

This document is an original document.

Cited standards and directives

The standards and directives cited in these operating instructions might have changed. The following list indicates the standards and directives that might have been cited and their successive versions.

Kindly replace the standards and directives cited in these operating instructions with the successive versions listed in the table.

Previous standard or directive	Successive standard and directive
Machinery Directive 98/37/EC	Machinery Directive 2006/42/EC
Directive 93/68/EEC	Directive 93/68/EC
EMC directive 89/336/EEC	EMC directive 2004/108/EC
Low Voltage Directive 73/23/EC	Low Voltage Directive 2006/95/EC
DIN 40050	EN 60529
IEC 536:1976	EN 61140
DIN EN 50178:1998-04/ VDE 0160:1998-04	EN 50178
EN 775	EN ISO 10218-1
EN 292-1	EN ISO 12100-1
EN 292-2	EN ISO 12100-2
EN 954-1	EN ISO 13849-1
EN 418	EN ISO 13850
EN 999	prEN ISO 13855
EN 294	EN ISO 13857
EN 811	EN ISO 13857
EN 1050	EN ISO 14121-1
IEC 68, part 2-27 or IEC 68	EN 60068-2-27
IEC 68, part 2-29	EN 60068-2-27
IEC 68, part 2-6	EN 60068-2-6
prEN 50100-1	EN 61496-1
ANSI B11.19-1990	ANSI B11.19:2003-04, Annex D

Electrical installation



WARNING

Prevent the formation of a potential difference between the load and the protective device!

- If you connect loads that are not reverse-polarity protected to the OSSDs or the safety outputs, you must connect the 0 V connections of these loads and those of the corresponding protective device individually and directly to the same 0 V terminal strip. This is the only way to ensure that, in the event of a defect, there can be no potential difference between the 0 V connections of the loads and those of the corresponding protective device.

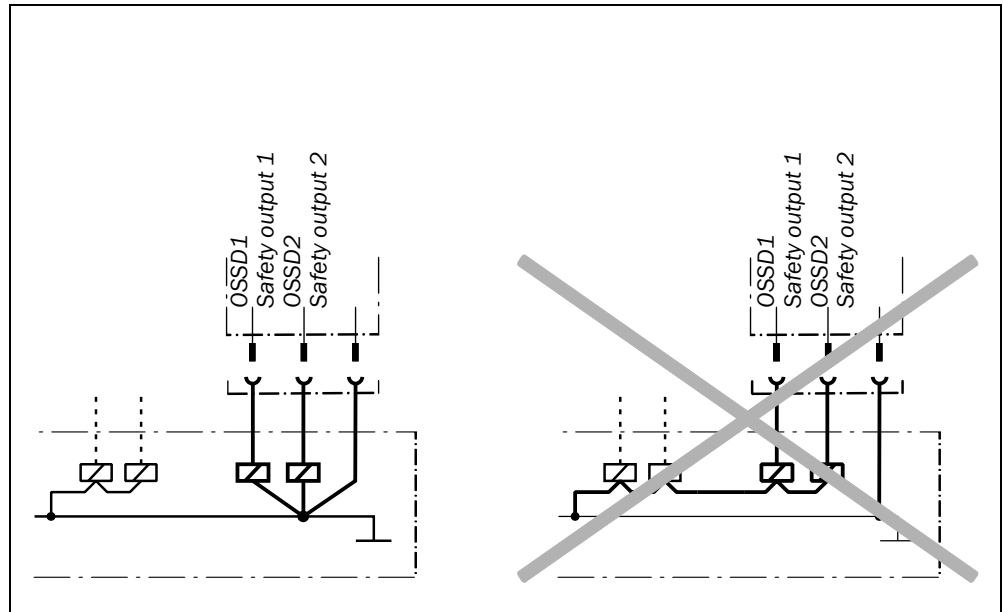

Technical specifications

Safety-related parameters according to EN ISO 13849, EN 62061, IEC 61508:

General system data	
Type	Type 4 (EN 61496-1)
Safety integrity level ¹⁾	SIL3 (IEC 61508)
SIL claim limit ¹⁾	SILCL3 (EN 62061)
Category	Category 4 (EN ISO 13849-1)
Performance Level ¹⁾	PL e (EN ISO 13849-1)
PFHd (mean probability of a dangerous failure per hour)	15×10^{-9}
T _M (mission time)	20 years (EN ISO 13849-1)

¹⁾ For detailed information on the exact design of your machine/system, please contact your local SICK representative.

EC declaration of conformity

The following declaration of conformity replaces the declaration of conformity that might be depicted in these operating instructions.

EC declaration of conformity
(page 1)

SICK	
TYPE: C4000 Basic / Micro / Basic+ / ECO	Ident-No.: 9140811
EC declaration of conformity	en
The undersigned, representing the following manufacturer herewith declares that the product is in conformity with the provisions of the following EC directive(s) (including all applicable amendments), and that the respective standards and/or technical specifications have been applied.	
EG-Konformitätserklärung	de
Der Unterzeichner, der den nachstehenden Hersteller vertritt, erklärt hiermit, dass das Produkt in Übereinstimmung mit den Bestimmungen der nachstehenden EG-Richtlinie(n) (einschließlich aller zutreffenden Änderungen) ist, und dass die entsprechenden Normen und/oder technischen Spezifikationen zur Anwendung gelangt sind.	
ЕС декларация за съответствие	bg
Подписалият, който представя долупоменатия производител, обявява, че продуктът съответва на разпоредбите на долуизброените директиви на ЕС (включително на всички действащи изменения) и че отговаря на съответните норми и/или технически спецификации за приложение.	
ES prohlášení o shodě	cs
Niže podepsaný, zastupující následujícího výrobce, tímto prohlašuje, že výrobek je v souladu s ustanoveními následující(ch) směrnice (směrnic) ES (včetně všech platných změn) a že byly použity odpovídající normy a/nebo technické specifikace.	
EF-overensstemmelseserklæring	da
Undertegnede, der repræsenterer følgende producent erklærer hermed at produktet er i overens-stemmelse med bestemmelserne i følgende EF-direktiv(er) (inklusive alle gældende ændringer) og at alle tilsvarende standarder og/eller tekniske specifikationer er blevet anvendt.	
ΕΕ-Δήλωση συμμόρφωσης	el
Ο Υπογράφων, εκπροσωπών τον ακόλουθο κατασκευαστή δηλώνει με το παρόν έγγραφο ότι το προϊόν συμμορφώνεται με τους όρους της (των) ακόλουθης (-ων) Οδηγίας (-ών) της ΕΕ (συμπεριλαμβανομένων όλων των εφαρμοζόμενων τροποποιήσεων) και ότι έχουν εφαρμοστεί τα αντίστοιχα πρότυπα και/ή οι τεχνικές προδιαγραφές.	
Declaración de conformidad CE	es
El abajo firmante, en representación del fabricante indicado a continuación, declara que el producto es conforme con las disposiciones de la(s) siguiente(s) directiva(s) de la CE (incluyendo todas las modificaciones aplicables) y que las respectivas normas y/o especificaciones técnicas han sido aplicadas.	
EÜ vastavusdeklaratsioon	et
Allkirjutanu, kes esindab järgmist tootjat, kinnitab käesolevaga, et antud toode vastab järgneva(te) EÜ direktiivi(de) sätetele (kaasa arvatud kõikidele asjakohastele muudatustele) ja et on kohaldatud vastavaid nõudeid ja/või tehnilisi kirjeldusi.	
EY-vaatimustenmukaisuusvakuutus	fi
Allekirjoittanut, joka edustaa alla mainittua valmistajaa, vakuuttaa täten, että tuote on seuraavan (-ien) EU-direktiivin (-ien) vaatimusten mukainen (mukaan lukien kaikki sovellettavat muutokset) ja että vastaavia standardeja ja teknisiä erittelyjä on sovellettu.	
Déclaration CE de conformité	fr
Le soussigné, représentant le constructeur ci-après, déclare par la présente que le produit est conforme aux exigences de la (des) directive(s) CE suivantes (y compris tous les amendements applicables) et que les normes et/ou spécifications techniques correspondantes ont été appliquées.	
EK megfelelőiségi nyilatkozat	hu
Alulírott, az alábbi gyártó képviselőtében ezennel kijelenti, hogy a termék megfelel az alábbi EK-irányelv(ek) követelményeinek (beleértve azok minden vonatkozó módosítását) és kijelenti hogy a megfelelő szabványokat és/vagy műszaki előírásokat alkalmazta.	
EB-samræmisýfirlýsing	is
Undirritaður, fyrir hönd framleiðandans sem nefndur er hér að neðan, lýsir því hér með yfir að varan er í samræmi við ákvæði eftirtalinnna EB-tilskipana (að meðtöldum öllum breytingum sem við eiga) og að varan er í samræmi við viðeigandi staðla og/eða tækniforskriftir.	
Dichiarazione CE di conformità	it
Il sottoscritto, rappresentante il seguente costruttore dichiara qui di seguito che il prodotto risulta in conformità a quanto previsto dalla(e) seguente(i) direttiva(e) comunitaria(e) (comprese tutte le modifiche applicabili) e che sono state applicate tutte le relative norme e/o specifiche tecniche.	
EB atitikties deklaracija	lt
Pasirašiusysis, atstovaujantis šiam gamintojų deklaruoja, kad gaminys atitinka šios (-ių) EB direktyvos (-ų) reikalavimus (įskaitant visus taikytinus keitinius) ir kad buvo taikomi antrajame puslapyje nurodyti standartai ir (arba) techninės specifikacijos.	

SICK**TYPE: C4000 Basic / Micro / Basic+ / ECO**

Ident-No.: 9140811

EK atbilstības deklarācija	lv
Apakšā parakstījies persona, kas pārstāv zemāk minēto ražotāju ar šo deklarē, ka izstrādājums atbilst zemāk minētajai (-ām) EK direktīvai (-ām) (ieskaitot visus atbilstošos grozījumus) un ka izstrādājumam ir piemēroti attiecīgie standarti un/vai tehniskās specifikācijas.	
EG-verklaring van overeenstemming	nl
Ondergetekende, vertegenwoordiger van de volgende fabrikant, verklaart hiermee dat het product voldoet aan de bepalingen van de volgende EG-richtlijn(en) (inclusief alle van toepassing zijnde wijzigingen) en dat de overeenkomstige normen en/of technische specificaties zijn toegepast.	
EF-samsvarserklæring	no
Undertegnede, som representerer nedennævnte produsent, erklærer herved at produktet er i samsvar med bestemmelsene i følgende EU-direktiv(er) (inkludert alle relevante endringer) og at relevante normer og/eller tekniske spesifikasjoner er blitt anvendt.	
Deklaracja zgodności WE	pl
Niżej podpisany, reprezentujący następującego producenta niniejszym oświadcza, że wyrób jest zgodny z postanowieniami następujących dyrektyw WE (wraz z odpowiednimi poprawkami) oraz, że zastosowano odpowiednie normy i/lub specyfikacje techniczne.	
Declaração CE de conformidade	pt
O abaixo assinado, que representa o seguinte fabricante, declara deste modo que o produto está em conformidade com as disposições da(s) seguinte(s) diretiva(s) CE (incluindo todas as alterações aplicáveis) e que foram aplicadas as respectivas normas e/ou especificações técnicas.	
Declarație de conformitate CE	ro
Semnatarul, în calitate de reprezentant al producătorului numit mai jos, declară prin prezenta că produsul este în conformitate cu prevederile directivelor CE enumerate mai jos (inclusiv cu toate modificările aferente) și că s-au întrunit normele și/sau specificațiile tehnice corespunzătoare.	
ES vyhlášení o zhode	sk
Dolu podpísaný zástupca výrobcu týmto vyhlasuje, že výrobok je v súlade s ustanoveniami nasledujúcej (nasledujúcich) smernice (smerníc) ES (vrátane všetkých platných zmien) a že sa použili príslušné normy a/alebo technické špecifikácie.	
Izjava ES o skladnosti	sl
Podpisani predstavnik spodaj navedenega proizvajalca izjavljam, da je proizvod v skladu z določbami spodaj navedenih direktiv ES (vključno z vsemi ustreznimi spremembami) in da so bili uporabljeni ustrezni standardi in/ali tehnične specifikacije.	
EG-försäkran om överensstämmelse	sv
Undertecknad, som representerar nedanstående tillverkare, försäkras härmed att produkten överensstämmer med bestämmelserna i följande EU-direktiv (inklusive samtliga tillämpliga tillägg till dessa) och att relevanta standarder och/eller tekniska specifikationer har tillämpats.	
AB-Uygunluk Beyanı	tr
Aşağıdaki üreticiyi temsil eden imza sahibi bölümlikle, ürünün aşağıdaki AB-Yönergesinin(lerin) direktifleri ile (tüm ilgili değişiklikleri kapsayacak şekilde) uyumlu olduğunu ve ilgili normların ve/veya teknik spesifikasyonların uygulandığını beyan eder.	

Directives used: MAS-DIRECTIVE 2006/42/EC
EMC-DIRECTIVE 2004/108/EC

You can obtain the EC declaration of conformity with the standards used at: www.sick.com

SICK AG	2009-11-12		
Erwin-Sick-Straße 1	Date	ppa. Dr. Georg Plasberg	ppa. Birgit Knobloch
D-79183 Waldkirch		Management Board	Division Manager Production
Germany		(Industrial Safety Systems)	(Industrial Safety Systems)
		authorized for technical documentation	

Checklist for the manufacturer**SICK****Checklist for the manufacturer/installer for the installation of electro-sensitive protective equipment (ESPE)**

Details about the points listed below must be present at least during initial commissioning – they are, however, dependent on the respective application, the specifications of which are to be controlled by the manufacturer/installer.

This checklist should be retained and kept with the machine documentation to serve as reference during recurring tests.

- | | | |
|--|------------------------------|-----------------------------|
| 1. Have the safety rules and regulations been observed in compliance with the directives/standards applicable to the machine? | Yes <input type="checkbox"/> | No <input type="checkbox"/> |
| 2. Are the applied directives and standards listed in the declaration of conformity? | Yes <input type="checkbox"/> | No <input type="checkbox"/> |
| 3. Does the protective device fulfil the required PL/SILCL and PFHd according to EN ISO 13 849-1/EN 62 061 and the type according to EN 61 496-1? | Yes <input type="checkbox"/> | No <input type="checkbox"/> |
| 4. Is the access to the hazardous area/hazardous point only possible through the protective field of the ESPE? | Yes <input type="checkbox"/> | No <input type="checkbox"/> |
| 5. Have appropriate measures been taken to prevent (mechanical protection) or monitor unprotected presence in the hazardous area when protecting a hazardous area/hazardous point and have these been secured against removal? | Yes <input type="checkbox"/> | No <input type="checkbox"/> |
| 6. Are additional mechanical protective measures fitted and secured against manipulation which prevent reaching under, over or around the ESPE? | Yes <input type="checkbox"/> | No <input type="checkbox"/> |
| 7. Has the maximum stopping and/or stopping/run-down time of the machine been measured, specified and documented (at the machine and/or in the machine documentation)? | Yes <input type="checkbox"/> | No <input type="checkbox"/> |
| 8. Has the ESPE been mounted such that the required safety distance from the nearest hazardous point has been achieved? | Yes <input type="checkbox"/> | No <input type="checkbox"/> |
| 9. Are the ESPE devices correctly mounted and secured against manipulation after adjustment? | Yes <input type="checkbox"/> | No <input type="checkbox"/> |
| 10. Are the required protective measures against electric shock in effect (protection class)? | Yes <input type="checkbox"/> | No <input type="checkbox"/> |
| 11. Is the control switch for resetting the protective device (ESPE) or restarting the machine present and correctly installed? | Yes <input type="checkbox"/> | No <input type="checkbox"/> |
| 12. Are the outputs of the ESPE (OSSDs, AS-Interface Safety at Work) integrated in compliance with the required PL/SILCL according to EN ISO 13 849-1/EN 62 061 and does the integration comply with the circuit diagrams? | Yes <input type="checkbox"/> | No <input type="checkbox"/> |
| 13. Has the protective function been checked in compliance with the test notes of this documentation? | Yes <input type="checkbox"/> | No <input type="checkbox"/> |
| 14. Are the given protective functions effective at every setting of the operating mode selector switch? | Yes <input type="checkbox"/> | No <input type="checkbox"/> |
| 15. Are the switching elements activated by the ESPE, e.g. contactors, valves, monitored? | Yes <input type="checkbox"/> | No <input type="checkbox"/> |
| 16. Is the ESPE effective over the entire period of the dangerous state? | Yes <input type="checkbox"/> | No <input type="checkbox"/> |
| 17. Once initiated, will a dangerous state be stopped when switching the ESPE on or off and when changing the operating mode, or when switching to another protective device? | Yes <input type="checkbox"/> | No <input type="checkbox"/> |
| 18. Has an information label for the daily check been attached so that it is easily visible for the operator? | Yes <input type="checkbox"/> | No <input type="checkbox"/> |

This checklist does not replace the initial commissioning, nor the regular inspection by qualified safety personnel.

List of contents

1	About this document.....	5
1.1	Function of this document.....	5
1.2	Target group	5
1.3	Depth of information.....	5
1.4	Scope	6
1.5	Abbreviations.....	6
1.6	Symbols used	6
2	On safety.....	8
2.1	Qualified safety personnel.....	8
2.2	Applications of the device.....	8
2.3	Correct use	9
2.4	General safety notes and protective measures	9
2.5	Protection of the environment.....	10
3	Product description.....	11
3.1	Special features	11
3.2	Operating principle of the device	12
3.2.1	Components of the device.....	12
3.2.2	The light curtain principle	12
3.3	Examples of range of use	13
3.4	Configurable functions.....	14
3.4.1	Restart interlock.....	14
3.4.2	External device monitoring (EDM).....	15
3.4.3	Scanning range	16
3.4.4	Sender test	17
3.5	Status indicators	17
3.5.1	Status indicators of the sender.....	17
3.5.2	Status indicators of the receiver	18
4	Installation and mounting.....	19
4.1	Determining the safety distance	19
4.1.1	Safety distance from the hazardous point	19
4.1.2	Minimum distance to reflective surfaces	22
4.2	Protection from affecting systems in close proximity	23
4.3	Steps for mounting the device	24
4.3.1	Mounting with swivel mount bracket.....	25
4.3.2	Mounting with side bracket	27
5	Electrical installation.....	29
5.1	System connection C4000 Basic (M26 × 6 + FE).....	30
5.2	System connection C4000 Eco (M12 × 4 + FE).....	30
5.3	System connection C4000 Micro/Basic Plus (M12 × 7 + FE)	31
5.4	External device monitoring (EDM).....	32
5.5	Reset button.....	33
5.6	Test input (sender test).....	33
5.7	Switching examples	34
5.7.1	C4000 Basic on UE48-20S/UE48-30S with restart interlock and EDM.....	34
5.7.2	C4000 Micro/Basic on UE10-30S without restart interlock, with EDM.....	35

6	Commissioning	36
6.1	Display sequence during start-up.....	36
6.2	Aligning sender and receiver.....	36
6.3	Test notes.....	37
6.3.1	Tests before the first commissioning.....	37
6.3.2	Regular inspection of the protective device by qualified safety personnel.....	37
6.3.3	Daily functional checks of the protective device.....	38
7	Configuration	39
7.1	Delivery status.....	39
7.2	Activating the restart interlock.....	39
7.3	Activating external device monitoring.....	39
7.4	Start-up configuration.....	39
8	Care and maintenance	41
9	Fault diagnosis	42
9.1	What to do in case of faults.....	42
9.2	SICK Support.....	42
9.3	Error displays of the diagnostics LEDs.....	42
9.4	Error displays of the 7-segment display.....	43
10	Technical specifications	44
10.1	Data sheet.....	44
10.2	Response time.....	48
10.3	Table of weights.....	49
10.3.1	C4000 Basic/Micro/Eco.....	49
10.3.2	Deflector mirrors PNS75 and PNS125.....	49
10.4	Dimensional drawings.....	50
10.4.1	C4000 Basic/Basic Plus/Eco.....	50
10.4.2	C4000 Micro.....	51
10.4.3	Swivel mount bracket.....	52
10.4.4	Side bracket.....	52
10.4.5	Deflector mirror PNS75.....	53
10.4.6	Deflector mirror PNS125.....	54
11	Ordering information	55
11.1	Delivery.....	55
11.2	C4000 Basic (M26 × 6 + FE).....	56
11.3	C4000 Eco (M12 × 4 + FE).....	57
11.4	C4000 Basic Plus (M12 × 7 + FE).....	58
11.5	C4000 Micro.....	59
11.6	Additional front screen (weld spark guard).....	60
11.7	Deflector mirror.....	61
11.7.1	Deflector mirror PNS75 for protective field width 0 ... 5.4 m (total).....	61
11.7.2	Deflector mirror PNS125 for protective field width 4 ... 5.4 m (total).....	61
11.8	Accessories.....	62
12	Annex	64
12.1	EC Declaration of Conformity.....	64
12.2	Checklist for the manufacturer.....	65
12.3	List of tables.....	66
12.4	List of illustrations.....	67

1 About this document

Please read this chapter carefully before working with this documentation and the safety light curtain C4000 Micro, C4000 Basic Plus, C4000 Basic or the C4000 Eco.

1.1 Function of this document

These operating instructions are designed to address *the technical personnel of the machine manufacturer or the machine operator* in regards to safe mounting, installation, electrical installation, commissioning, operation and maintenance of the safety light curtain C4000 Micro, C4000 Basic Plus, C4000 Basic or C4000 Eco.

These operating instructions do *not* provide instructions for operating machines on which the safety light curtain is, or will be, integrated. Information on this is to be found in the appropriate operating instructions of the machine.

1.2 Target group

These operating instructions are addressed to *planning engineers, developers and the operators* of plant and systems which are to be protected by one or several safety light curtains C4000. It also addresses people who integrate the C4000 into a machine, initialise its use, or who are in charge of servicing and maintaining the device.

1.3 Depth of information

These operating instructions contain information on:

- Installation and mounting
- Electrical installation
- Commissioning
- Care and maintenance
- Fault, error diagnosis and troubleshooting
- Part numbers
- Conformity and approval

of the safety light curtain C4000.

Planning and using protective devices such as the C4000 also require specific technical skills which are not detailed in this documentation.

When operating the C4000, the national, local and statutory rules and regulations must be observed.

General information on accident prevention using opto-electronic protective devices can be found in the brochure "Safe Machines with opto-electronic protective devices".

Note We also refer you to the SICK homepage on the Internet at: www.sick.com

Here you will find information on:

- Sample applications
- A list of frequently asked questions about the C4000
- These operating instructions in different languages for viewing and printing
- Certificates on the prototype test, the EC declaration of conformity and other documents

1.4 Scope

Note These operating instructions only apply to the safety light curtains C4000 Basic, C4000 Basic Plus, C4000 Micro and C4000 Eco with one of the following entries on the type label in the field *Operating Instructions*:

- 8009410/N082
- 8009410/0855
- 8009410/TI70

This document is part of SICK part number 8009410 (operating instructions “Safety light curtain C4000 Micro, C4000 Basic Plus, C4000 Basic, C4000 Eco” in all available languages).

1.5 Abbreviations

ESPE Electro-sensitive protective equipment (e.g. C4000)
OSSD Output signal switching device

1.6 Symbols used

Recommendation Recommendations are designed to give you some assistance in your decision-making process with respect to a certain function or a technical measure.

Note Refer to notes for special features of the device.

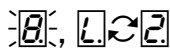

Display indicators show the status of the 7-segment display of sender or receiver:

- Constant indication of characters, e.g. 9
- Flashing indication of characters, e.g. 8
- Alternating indication of characters, e.g. L and 2

● Red, ● Yellow,
○ Green

LED symbols describe the state of a diagnostics LED. Examples:

- **Red** The red LED is illuminated constantly.
- **Yellow** The yellow LED is flashing.
- **Green** The green LED is off.

➤ Take action ...

Instructions for taking action are shown by an arrow. Carefully read and follow the instructions for action.



WARNING

Warning!

A warning notice indicates an actual or potential risk or health hazard. They are designed to help you to prevent accidents.

Read carefully and follow the warnings!



Sender and receiver

In drawings and diagrams, the symbol denotes the sender and the symbol denotes the receiver.

The term “dangerous state”

The dangerous state (standard term) of the machine is always shown in the drawings and diagrams of this document as the movement of a machine part. In practical operation, there may be a number of different dangerous states:

- Machine movements
- Electrical conductors
- Visible or invisible radiation
- A combination of several risks and hazards

2 On safety

This chapter deals with your own safety and the safety of the equipment operators.

- Please read this chapter carefully before working with the C4000 or with the machine protected by the C4000.

2.1 Qualified safety personnel

The safety light curtain C4000 must be installed, commissioned and serviced only by qualified safety personnel. Qualified safety personnel are defined as persons who

- have undergone the appropriate technical training

and

- who have been instructed by the responsible machine operator in the operation of the machine and the current valid safety guidelines

and

- who have access to these operating instructions.

2.2 Applications of the device

The safety light curtain C4000 is an electro-sensitive protective equipment (ESPE). The physical resolution is 14 or 30 mm with a maximum protective field width of 6 metres. The realisable protective field height is between 300 and 1,800 mm for the C4000 Basic/Eco and between 150 and 1,200 mm for the C4000 Micro.

The device is a *Type 4 ESPE* as defined by IEC 61496-1 and -2 and is therefore allowed for use with controls in safety category 4 in compliance with EN 954-1. The device is suitable for

- Hazardous point protection (finger and hand protection)
- Hazardous area protection
- Access protection

Access to the hazardous point must be allowed only through the protective field. The plant/system is not allowed to start as long as personnel are within the hazardous area. Refer to chapter 3.3 “Examples of range of use” on page 13 for an illustration of the protection modes.



WARNING

Only use the safety light curtain as an indirect safety measure!

An opto-electronic protective device provides indirect protection, e.g., by switching off the power at the source of the hazard. It cannot provide protection from parts thrown out, nor from emitted radiation. Transparent objects are not detected.

Depending on the application, mechanical protective devices may be required in addition to the safety light curtain.

Note The safety light curtain C4000 Basic, C4000 Micro or C4000 Eco operates as a standalone system, comprising a sender and receiver. It cannot be combined with other C4000 systems, e.g. C4000 Advanced.

2.3 Correct use

The safety light curtain C4000 must be used only as defined in chapter 2.2 “Applications of the device”. It must be used only by qualified personnel and only on the machine where it has been installed and initialised by qualified safety personnel in accordance with these operating instructions.

If the device is used for any other purposes or modified in any way – also during mounting and installation – any warranty claim against SICK AG shall become void.

2.4 General safety notes and protective measures



WARNING

Safety notes

Please observe the following procedures in order to ensure the correct and safe use of the safety light curtain C4000.

- The national/international rules and regulations apply to the installation, commissioning, use and periodic technical inspections of the safety light curtain, in particular:
 - Machine Directive 98/37/EEC
 - Equipment Usage Directive 89/655/EEC
 - the work safety regulations/safety rules
 - other relevant health and safety regulations

Manufacturers and operators of the machine with which the safety light curtain is used are responsible for obtaining and observing all applicable safety regulations and rules.

- The notices, in particular the test regulations (see “Test notes” on page 37) of these operating instructions (e.g. on use, mounting, installation or integration into the existing machine controller) must be observed.
- The tests must be carried out by qualified safety personnel or specially qualified and authorised personnel and must be recorded and documented to ensure that the tests can be reconstructed and retraced at any time.
- The operating instructions must be made available to the operator of the machine where the safety light curtain C4000 is fitted. The machine operator is to be instructed in the use of the device by qualified safety personnel and must be instructed to read the operating instructions.
- The external voltage supply of the device (SELV/PELV) must be capable of buffering brief mains voltage failures of 20 ms as specified in EN 60204-1. Suitable power supplies are available as accessories from SICK (SICK Power Supply 50 W (Part number 7028789)/SICK Power Supply 95 W (Part number 7028790)).

2.5 Protection of the environment

The safety light curtain C4000 has been designed to minimise environmental impact. It uses only a minimum of power and natural resources.

At work, always act in an environmentally responsible manner. For this reason please note the following information on disposal.

Disposal

- Always dispose of unserviceable or irreparable devices in compliance with local/national rules and regulations with respect to waste disposal.

Note We would be pleased to be of assistance on the disposal of this device. Contact your local SICK representative.

3 Product description

This chapter provides information on the special features and properties of the safety light curtain C4000. It describes the construction and the operating principle of the device, in particular the different operating modes.

➤ Please read this chapter before mounting, installing and commissioning the device.

3.1 Special features

C4000 Basic

- Protective operation
- Facility for connecting the reset button, model-dependent
- Connection option for external device monitoring (EDM), model-dependent
- Protective operation with either internal or external restart interlock (realised on machine), model-dependent
- Status display with 7-segment display

The C4000 Basic is available in two designs (models).

Tab. 1: C4000 Basic model overview

Designation (Connection Format)	External device monitoring (EDM)	Restart interlock	Reset button
C4000 Basic Plus (M12 × 7 + FE)	yes	yes	yes
C4000 Basic (M26 × 6 + FE, Hirschmann-plug)	yes	no	no

C4000 Micro

- Protective operation with either internal or external (realised on the machine) restart interlock
- Facility for connecting the reset button
- Facility for connecting the external device monitoring (EDM)
- Status display with 7-segment display

The C4000 Micro is available in one design.

Tab. 2: C4000 Micro model overview

Designation (Connection Format)	External device monitoring (EDM)	Restart interlock	Reset button
C4000 Micro (M12 × 7 + FE)	yes	yes	yes

C4000 Eco

- Protective operation
- Status display with 7-segment display

The C4000 Eco is available in one design.

Tab. 3: C4000 Eco model overview

Designation (Connection Format)	External device monitoring (EDM)	Restart interlock	Reset button
C4000 Eco (M12 × 4 + FE)	no	no	no

3.2 Operating principle of the device

3.2.1 Components of the device

Fig. 1: Components of the C4000

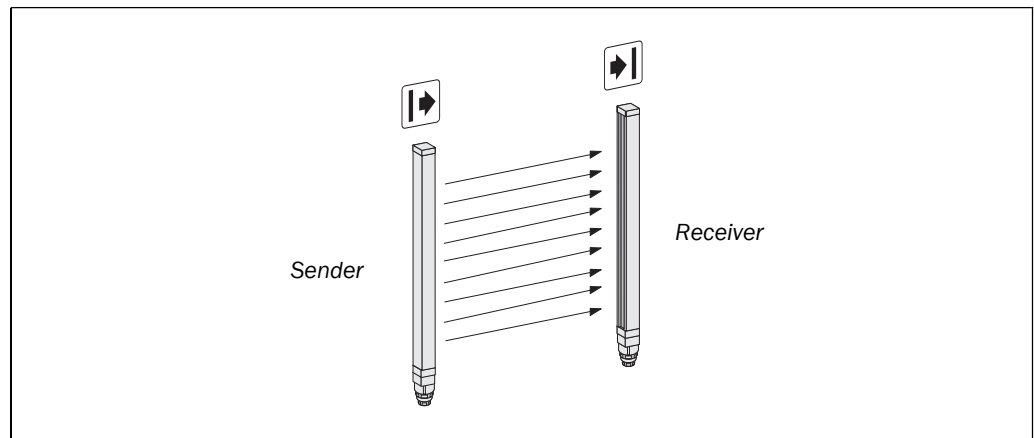

Please refer to chapter 10 “Technical specifications” on page 44 for the data sheet.
Please refer to pages 50 ff. for the dimensional drawings.

3.2.2 The light curtain principle

The safety light curtain C4000 consists of a sender and a receiver (Fig. 1). Between these two units is the protective field, defined as the protective field height and the protective field width.

The construction height determines the *protective field height* of the appropriate system. For the exact protective field height, please see Tab. 21 ff. in chapter 10.4 “Dimensional drawings” on page 50.

The *protective field width* is derived from the dimension of the light path between sender and receiver and must not exceed the maximum rated protective field width (see “Technical specifications” on page 44).

Sender and receiver automatically synchronise themselves optically. An electrical connection between both components is not required.

The C4000 is modular in structure. All optical and electronic components and assemblies are housed in a slim and torsionally rigid housing.

3.3 Examples of range of use

Fig. 2: Protecting hazardous points with a safety light curtain C4000 (left)

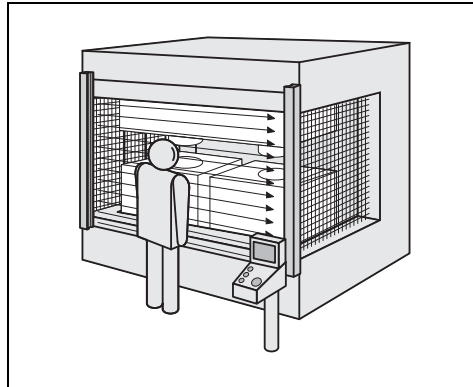

Fig. 3: Hazardous area protection with a safety light curtain C4000 (right)

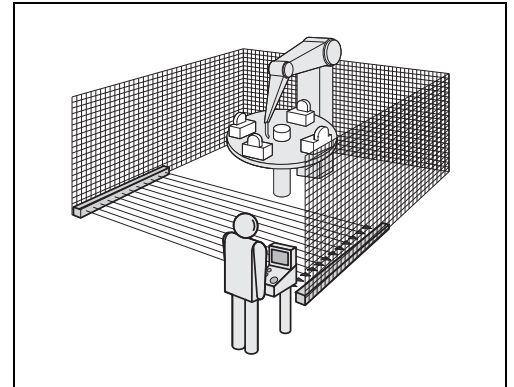
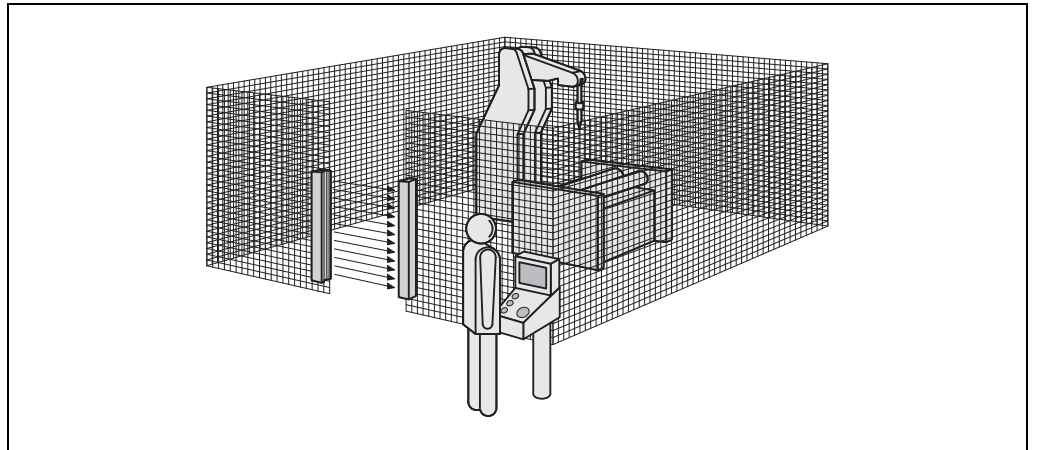

Fig. 4: Access protection using a safety light curtain C4000



The safety light curtain C4000 operates correctly as a protective device only if the following conditions are met:

- The control of the machine must be electrical.
- The dangerous state of the machine must be transferable at any time into a safe state.
- Sender and receiver unit must be so mounted that objects penetrating the hazardous area are safely identified by the C4000.
- The reset button must be fitted outside the hazardous area such that it cannot be operated by a person working inside the hazardous area. When operating the reset button, the operator must have full visual command of the hazardous area.
- The statutory and local rules and regulations must be observed when installing and using the device.

3.4 Configurable functions

This chapter describes the functions of the safety light curtains C4000 Basic and C4000 Micro.



WARNING

Test the protective device after any changes!

After each modification to the protective device or its connection, you must check the whole protective device for effectiveness (see 6.3 on Page 37).

3.4.1 Restart interlock

Fig. 5: Outline drawing of the protective operation

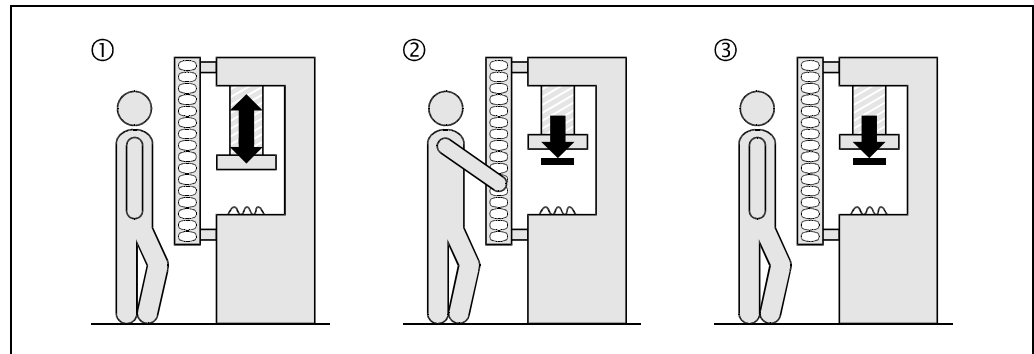

The C4000 Micro/Basic has an internal restart interlock. The dangerous state of the machine (①) is interrupted if the light path is broken (②), and is not re-enabled (③) until the operator presses the reset button.

- Notes**
- If you use the C4000 Micro/Basic without internal restart interlock, then you must implement the restart interlock externally, i.e. on the machine.
 - Do not confuse the restart interlock with the starting interlock on the machine. The start interlock prevents the machine starting after switching on. The restart interlock prevents the machine starting again after an error or an interruption in the light path.

When using the C4000 Micro/Basic, you can implement the restart interlock in two different ways:

- With the internal restart interlock of the C4000 Micro/Basic:
The C4000 Micro/Basic controls the restart.
- With the restart interlock of the machine (external):
The C4000 Micro/Basic has no control over the restart.

C4000 Micro/Basic/Basic Plus/Eco

Tab. 4: Permissible configuration of the restart interlock of the C4000 Micro/Basic

The possible combinations are shown in the following table:

Restart interlock of the C4000 Micro/Basic	Restart interlock of the machine	Permissible application
deactivated	deactivated	Only if the light curtain cannot be stood behind. Observe EN 60 204-1!
deactivated	activated	All
activated	deactivated	Only if the light curtain cannot be stood behind. Observe EN 60 204-1!
activated	activated	All. The restart interlock of the C4000 Micro handles the reset function (see “Reset” below).



WARNING

Always configure the application with restart interlock!

Ensure that there is always a restart interlock. The C4000 is unable to verify if the restart interlock of the machine is operable. If you deactivate both the internal and the machine’s restart interlock, the operators of the machine will be at an acute risk of injury.

The electrical connection of the reset button is described in chapter “Reset button” on page 33.

Reset

If you want to activate the restart interlock on the C4000 Micro/Basic (internal) and also a restart interlock on the machine (external), then each restart interlock has its own button. When actuating the reset button (for the internal restart interlock)

- the C4000 Micro/Basic activates the switching outputs
- the safety light curtain changes from red to green

Only the external restart interlock prevents the machine from restarting. After pressing the reset button for the C4000 Micro/Basic, the operator must also press the restart button for the machine. If the reset button and the restart button are not pressed in the specified sequence, the dangerous state remains disrupted.



Recommendation

The reset button prevents the accidental and inadvertent operation of the external restart button. The operator must first acknowledge the dangerous state with the reset button.

The electrical connection of the reset button is described in chapter “Reset button” on page 33. The configuration of the reset button is described in chapter 7.2 “Activating the restart interlock” on page 39.

3.4.2 External device monitoring (EDM)

C4000 Micro and C4000 Basic have an EDM. The external device monitoring (EDM) checks if the contactors actually de-energise when the protective device responds. If you activate external device monitoring, then the C4000 checks the contactors after each interruption to the light path and prior to machine restart. The EDM can so identify if one of the contactors has fused, for instance. In this case

- the error message  appears in the 7-segment display
- the safety light curtain remains red
- with the internal restart interlock activated, the safety light curtain uses the flashing LED  **Yellow** to signal “Reset required”

Note If the system is unable to change to a safe operational state (e.g. after contactor failure), the system locks and shuts down completely (“Lock-out”). The 7-segment display will then show the error message .

The electrical connection for the external device monitoring is described in chapter “External device monitoring (EDM)” on page 32. The configuration of the external device monitoring is described in chapter 7.4 “Start-up configuration” on page 39.

3.4.3 Scanning range

The safety light curtain is available with different scanning ranges. An overview is contained in Tab. 6.



WARNING

Only use devices with a scanning range that matches the protective field width!

- If the scanning range is set too low, the light curtain may not switch to green.
- If the scanning range is set too great, the light curtain may malfunction. This would mean that the operator is at risk.

Notes

- The additional front screens, which are available as accessories (see page 60), reduce the effective scanning range per additional front screen by 8%.

Tab. 5: Scanning range of the C4000 without and with additional front screen

Physical resolution	Available scanning ranges	Scanning range with 1 additional front screen	Scanning range with 2 additional front screens
14 mm	0–2.5 m	0–2.3 m	0–2.1 m
	1–5 m	0.9–4.6 m	0.7–4.2 m
30 mm	0–6 m	0–5.5 m	0–5 m

- The deflector mirrors available as accessories (see page 61) reduce the overall scanning range depending on the number of deflector mirrors in the light path (see section 11.7.1 for PNS75 and section 11.7.2 for PNS125).



WARNING

Do not use deflector mirrors if the formation of droplets or heavy contamination of the deflector mirrors is to be expected!

The formation of droplets or heavy contamination can be detrimental to the reflection behaviour. The protective function of the system will be affected and the system will thus become unsafe. This would mean that the operator is at risk.

Tab. 6: Scanning range when using 1 or 2 deflector mirrors

Deflector mirror	14 mm	30 mm
1 × PNS75	4.4 m	5.0 m
2 × PNS75	2.4 m	3.3 m
1 × PNS125	4.4 m	5.3 m
2 × PNS125	2.8 m	3.8 m

The information in the table relates to 90° beam deflection per mirror and a protective field height of 900 mm. If you need more advice on mirror applications, please get in touch with your contact at SICK.

3.4.4 Sender test

The C4000 sender (except C4000 Basic M12 x 4 + FE) has a test input for checking the sender and the related receiver. During the test, the sender no longer emits light beams. Thus, it simulates – for the receiver – an interruption of the protective field.

- During the test the sender indicates .
- The test is successful, if the C4000 receiver switches to red, i.e. the switching outputs (OSSDs) are deactivated.

Note C4000 sender and receiver are self-testing. You only need to configure the function of the sender test if this is necessary for an older existing application.

In order to perform a sender test, a means of controlling the test input must be available. The electrical connection at the test input is described in chapter 5.6 “Test input (sender test)” on page 33.

3.5 Status indicators



The LEDs and the 7-segment display of sender and receiver signal the operating status of the C4000.

3.5.1 Status indicators of the sender

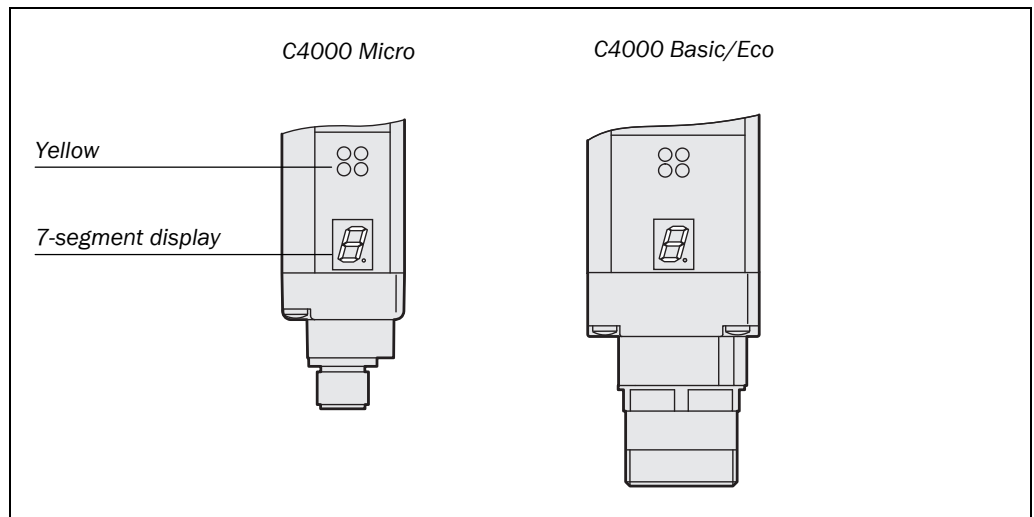
Fig. 6: Status indicators of the sender



Tab. 7: Status indicators of the sender

Display	Meaning
● Yellow	Supply voltage OK
	System error. The device is defective. Replace the sender.
	The device is in the test mode.
	Non-coded operation (only after switching on)
Other displays	All other displays are error messages. Please refer to chapter “Fault diagnosis” on page 42.

3.5.2 Status indicators of the receiver

Fig. 7: Status indicators of the receiver

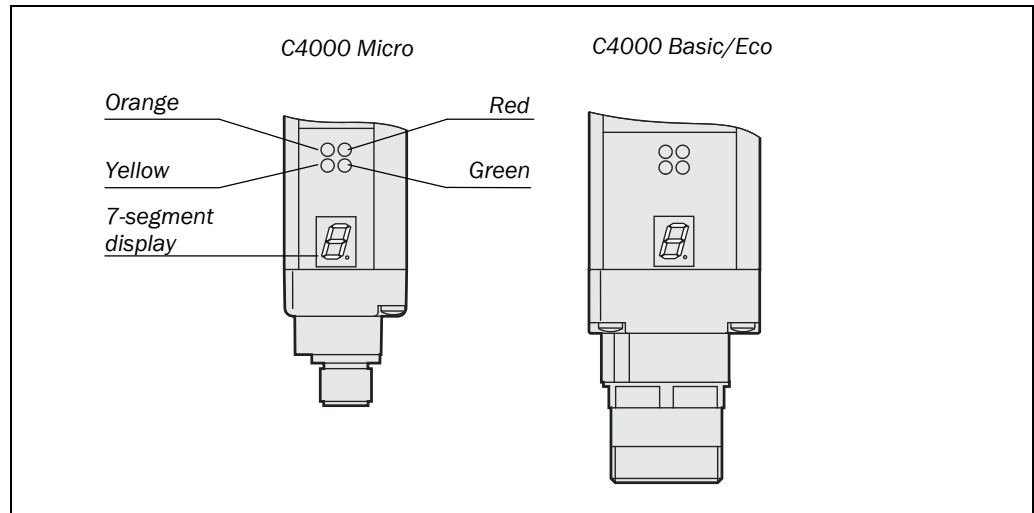

Tab. 8: Status indicators of the receiver

Display	Meaning
● Orange	Cleaning or realignment required
● Yellow	Reset required
● Red	System providing signals for shutting down the machine (switching output off)
● Green	System enabled (switching output on)
	System error. The device is defective. Replace the receiver.
	Poor alignment to sender.
	Please refer to chapter 6.2 "Aligning sender and receiver" on page 36.
	Approx. 1 s. Device waits for start-up configuration (Only after switching on. See section 7.4 "Start-up configuration" on page 39).
	Approx. 0.5 s. Only for systems with a resolution of 14 mm and a scanning range of 1–5 m: Operation with large protective field width (only after switching on)
	Non-coded operation (only after switching on)
Other displays	All other displays are error messages. Please refer to chapter "Fault diagnosis" on page 42.

4 Installation and mounting

This chapter describes the preparation and completion of the installation of the safety light curtain C4000. The installation and mounting requires two steps:

- Determining the necessary safety distance
- Installation with swivel mount or side brackets

The following steps are necessary after mounting and installation:

- Making the electrical connections (chapter 5)
- Aligning sender and receiver (chapter 6.2)
- Checking the installation (chapter 6.3)

4.1 Determining the safety distance

The light curtain must be mounted with the correct safety distance

- from the hazardous point
- from reflective surfaces



WARNING

No protective function without large enough safety distance!

The reliable protective effect of the light curtain depends on the system being mounted with the correct safety distance from the hazardous point.

4.1.1 Safety distance from the hazardous point

A safety distance must be maintained between the light curtain and the hazardous point. This safety distance ensures that the hazardous point can only be reached after the dangerous state of the machine has been completely stopped.

The safety distance as defined in EN 999 and EN 294 depends on:

- Stopping/run-down time of the machine or system
(The stopping/run-down time is shown in the machine documentation or must be determined by taking a measurement.)
- Response time of the entire protective device, e.g. C4000 (response times see chapter "Response time" on page 48)
- Reach or approach speed
- Resolution of the light curtain and/or beam separation
- Other parameters that are stipulated by the standard depending on the application

Under the authority of OSHA and ANSI the safety distance as specified by ANSI B11.191990 E.4.2.3.3.5 and Code of Federal Regulations, Volume 29, Part 1910.217 ... (h) (9) (v) depends on:

- Stopping/run-down time of the machine or system
(The stopping/run-down time is shown in the machine documentation or must be determined by taking a measurement.)
- Response time of the entire protective device, e.g. C4000 (response times see chapter "Response time" on page 48)
- Reach or approach speed
- Other parameters that are stipulated by the standard depending on the application

Fig. 8: Safety distance from the hazardous point

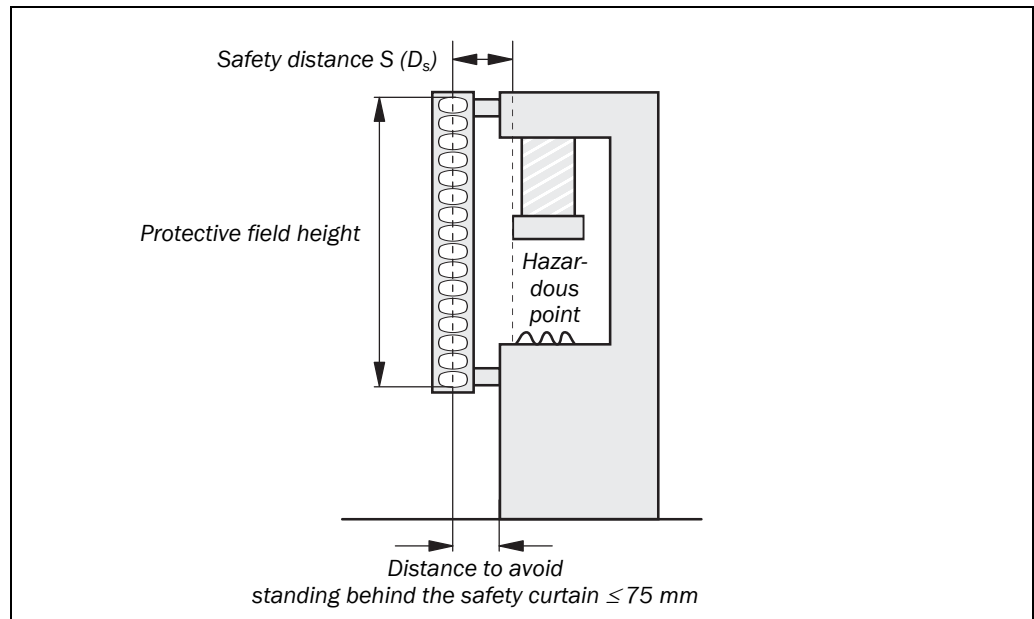

How to calculate the safety distance S according to EN 999 and EN 294:

Note The following calculation shows an example calculation of the safety distance. Depending on the application and the ambient conditions, a different calculation may be necessary.

➤ First, calculate S using the following formula:

$$S = 2000 \times T + 8 \times (d - 14) \text{ [mm]}$$

Where ...

T = Stopping/run-down time of the machine

+ Response time of the protective device after light path interruption [s]

d = Resolution of the light curtain [mm]

S = Safety distance [mm]

The reach/approach speed is already included in the formula.

➤ If the result S is ≤ 500 mm, then use the determined value as the safety distance.

➤ If the result S is > 500 mm, then recalculate S as follows:

$$S = 1600 \times T + 8 \times (d - 14) \text{ [mm]}$$

➤ If the new value S is > 500 mm, then use the newly determined value as the minimum safety distance.

➤ If the new value S is ≤ 500 mm, then use 500 mm as the minimum safety distance.

Example:

Stopping/run-down time of the machine = 290 ms

Response time after light path interruption = 30 ms

Resolution of the light curtain = 14 mm

$$T = 290 \text{ ms} + 30 \text{ ms} = 320 \text{ ms} = 0.32 \text{ s}$$

$$S = 2000 \times 0.32 + 8 \times (14 - 14) = 640 \text{ mm}$$

$S > 500$ mm, therefore:

$$S = 1600 \times 0.32 + 8 \times (14 - 14) = \underline{\underline{512 \text{ mm}}}$$

How to calculate the safety distance D_s according to ANSI B11.19-1990 E.4.2.3.3.5 and Code of Federal Regulations, Volume 29, Part 1910.217 ... (h) (9) (v):

Note The following calculation shows an example calculation of the safety distance. Depending on the application and the ambient conditions, a different calculation may be necessary.

➤ Calculate D_s using the following formula:

$$D_s = H_s \times (T_s + T_c + T_r + T_{bm}) + D_{pf}$$

Where ...

D_s = The minimum distance in inches (or millimetres) from the hazardous point to the protective device

H_s = A parameter in inches/second or millimetres/second, derived from data on approach speeds of the body or parts of the body. Often 63 inches/second (1600 millimetres/second) is used for H_s .

T_s = Stopping/run down time of the machine tool measured at the final control element

T_c = Stopping/run-down time of the control system

T_r = Response time of the entire protective device after light path interruption

T_{bm} = Additional response time allowed for brake monitor to compensate for wear

Note Any additional response times must be accounted for in this calculation.

D_{pf} = An additional distance added to the overall safety distance required. This value is based on intrusion toward the hazardous point prior to actuation of the electro-sensitive protective equipment (ESPE). Values range from 0.25 inches to 48 inches (6 millimetres to 1220 millimeters) or more depending on application.

Example:

In opto-electronic protecting, such as with a perpendicular safety light curtain applications with object sensitivity (effective resolution) less than 2.5 inches (64 millimetres), the D_{pf} can be approximated based on the following formula:

$$D_{pf} \text{ (inches)} = 3.4 \times (\text{Object Sensitivity} - 0.276), \text{ but not less than } 0.$$

4.1.2 Minimum distance to reflective surfaces

The light beams from the sender may be deflected by reflective surfaces. This can result in failure to identify an object.

All reflective surfaces and objects (e.g. material bins) must therefore be located at a minimum distance a from the protective field of the system. The minimum distance a depends on the distance D between sender and receiver.

Fig. 9: Minimum distance to reflective surfaces

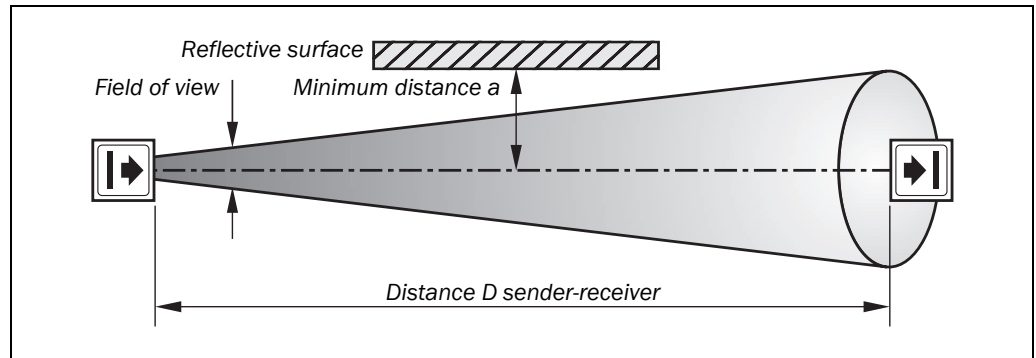

Note The field of view of the sender and receiver optics is identical.

How to determine the minimum distance from reflective surfaces:

- Determine the distance D [m] sender-receiver.
- Read the minimum distance a [mm] from the graph:

Fig. 10: Graph, minimum distance from reflective surfaces

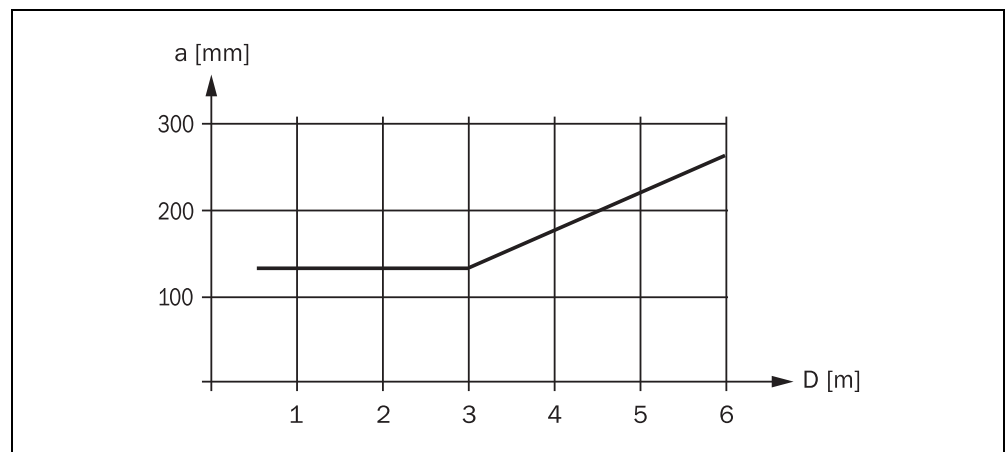

4.2 Protection from affecting systems in close proximity



WARNING

Prevent the affection of systems mounted in close proximity

If several safety light curtains operate in close proximity to each other, the sender beams of one system may interfere with the receiver of another system. This can disrupt the protective function of the system. This would mean that the operator is at risk. You must avoid such mounting scenarios or take appropriate measures, e.g. by mounting non-reflective sight protection walls or by reversing the transmission direction of a system.

Fig. 11: Unwanted influencing of a 2nd C4000 system. The receiver of the 2nd system is affected by the beams of the 1st system.

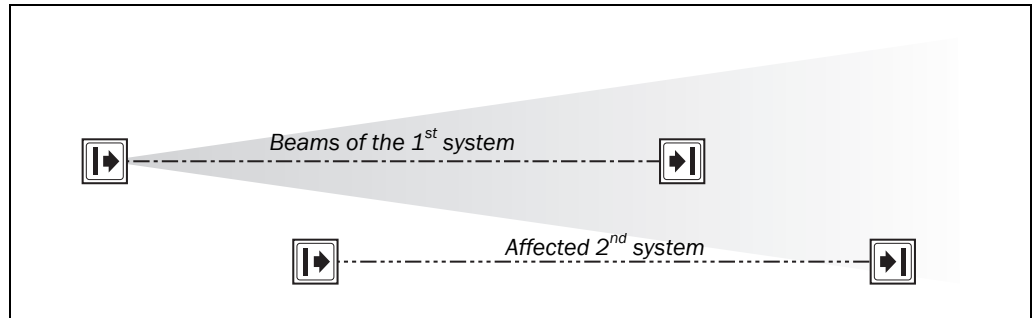
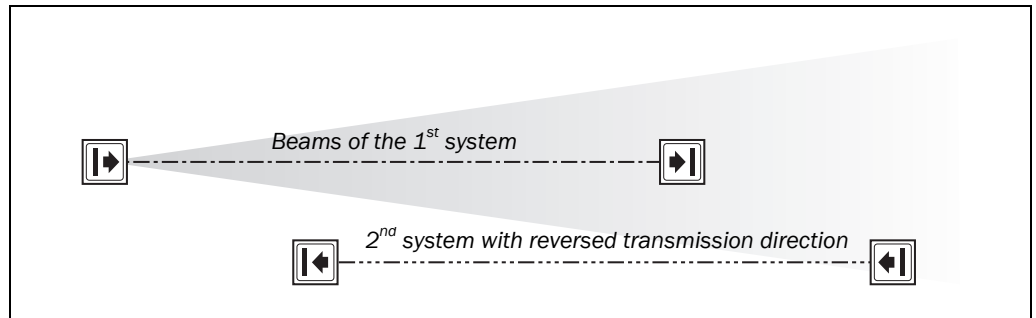

Fig. 12: Reversing the transmission direction of systems in close proximity. The sender of the 2nd system is not affected by the beams of the 1st system.



4.3 Steps for mounting the device



WARNING

Special features to note during mounting:

- Always mount the sender and receiver parallel to one another.
- During mounting, make sure that sender and receiver are aligned correctly. The optical lens systems of sender and receiver must be located in exact opposition to each other; the display elements must be mounted at the same height. The system plugs of both devices must point in the same direction.
- Take suitable measures to attenuate vibration if the shock requirements are above the values given in chapter 10.1 “Data sheet” on page 44.
- Observe the safety distance of the system during mounting. On this topic read the chapter “Determining the safety distance” on page 19.
- Mount the safety light curtain such that the hazardous point cannot be reached from below, above or behind the safety light curtain and that the light curtain cannot be repositioned.

Fig. 13: The correct installation (above) must eliminate the errors (below) stepping behind, reaching below and reaching above.

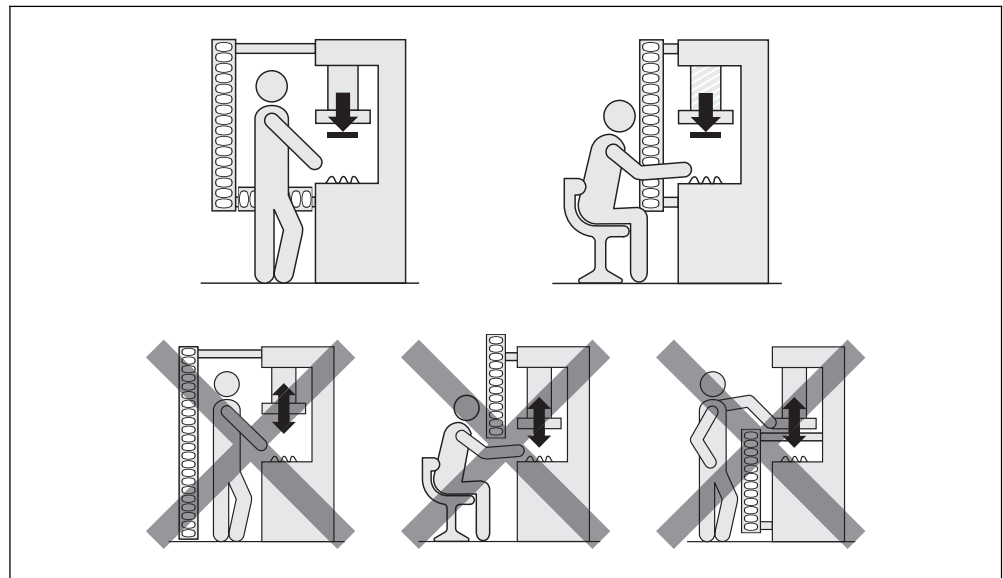

- Once the system is mounted, one or several of the enclosed self-adhesive safety information labels must be affixed.
 - Use only information labels in the language which the operators of the machine understand.
 - Affix the information labels such that they are easily visible by the operators during operation. After attaching additional objects and equipment, the information labels must not be concealed from view.
 - Affix the information label “Important Notices” to the system in close proximity to sender and receiver.

The senders and receivers can be mounted in two different ways:

- Mounting with swivel mount bracket
- Mounting with side bracket

4.3.1 Mounting with swivel mount bracket

The swivel mount bracket is made of black plastic. The bracket is designed such that sender and receiver can still be accurately aligned even after the bracket has been mounted. The swivel mount bracket is also suitable for mounting the deflector mirrors PNS75 and PNS125 (see chapter 10.4.5f. on page 53f.).

- Note** ➤ Attach the bolts of the swivel mount bracket with a torque of between 2.5 and 3 Nm. Higher torques can damage the bracket; lower torques provide inadequate protection against vibration.

Fig. 14: Composition of the swivel mount bracket

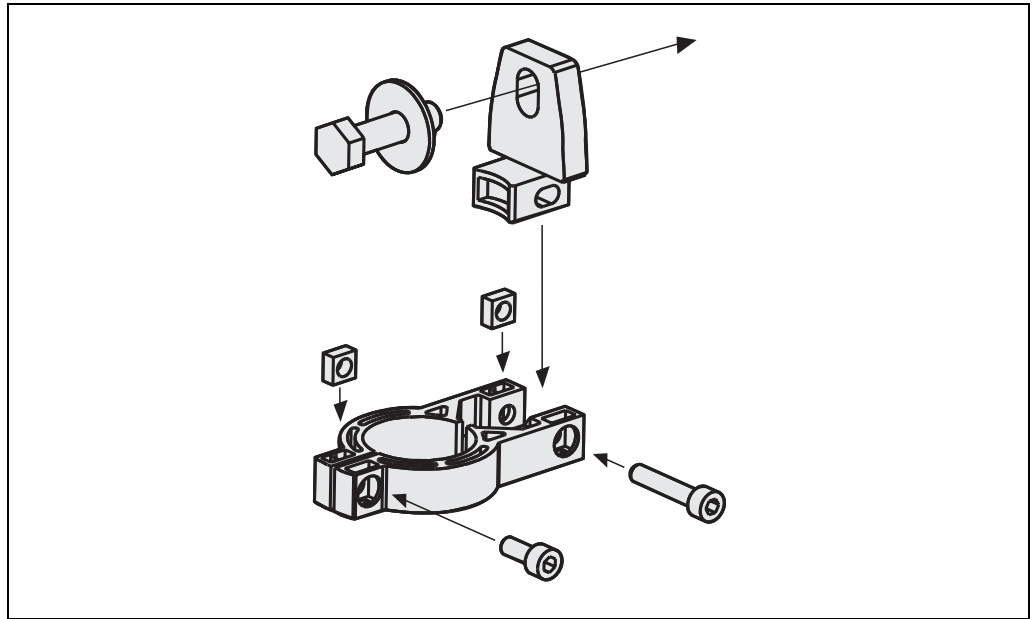
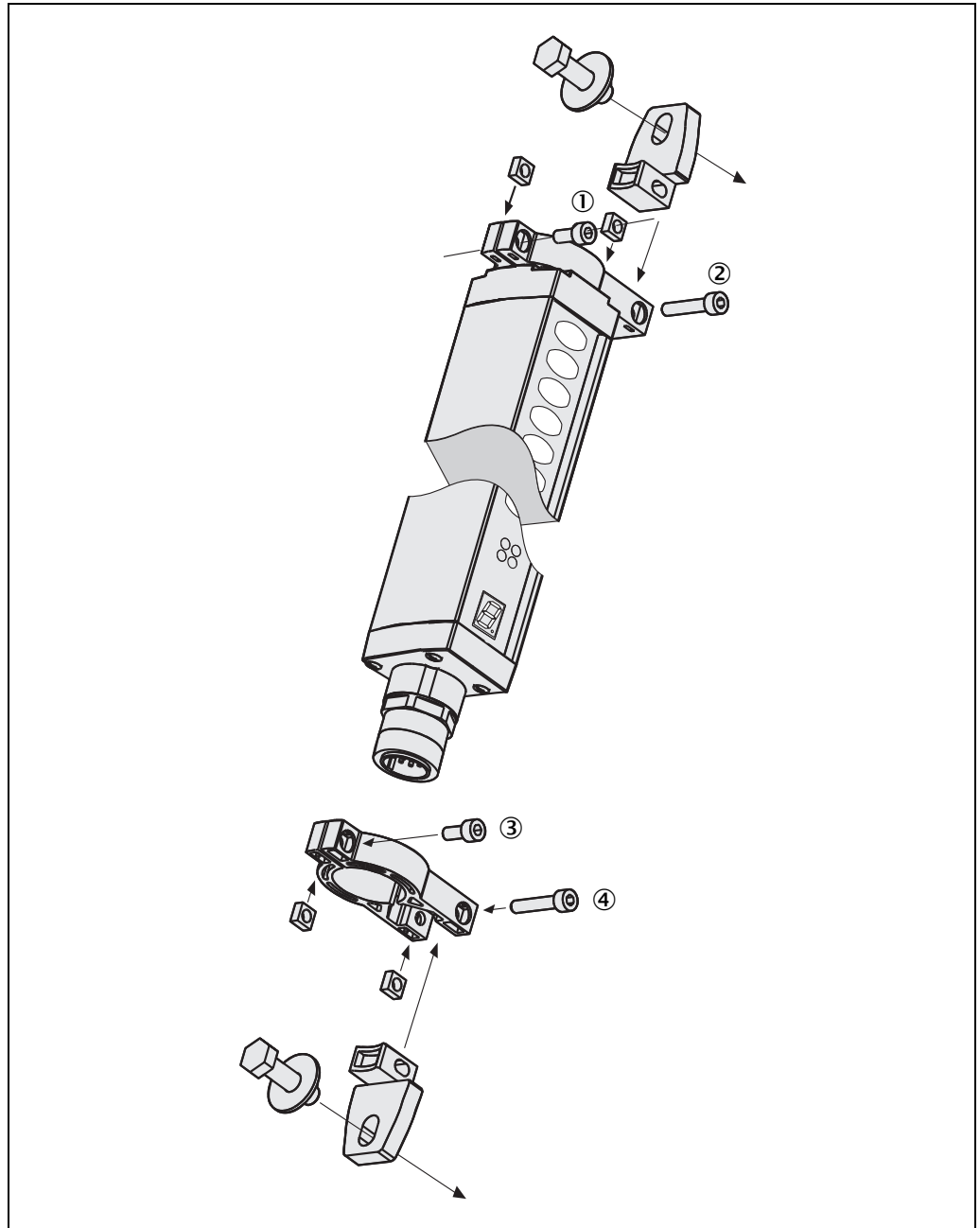

Fig. 15: Mounting sender and receiver using swivel mount brackets



- Notes**
- Mount the bolts marked with ① to ④ on the operator side of the system to ensure that they remain accessible after mounting and to allow you to readjust the light curtain later, if necessary.
 - If you wish to use the additional front screen (see “Additional front screen (weld spark guard)” on page 60), make sure that the curved side of the device remains accessible after mounting.

4.3.2 Mounting with side bracket

The side bracket is made of die cast zinc. It is enamelled in black. The side bracket will be covered by the device after mounting. But it is only suitable for mounting surfaces lying parallel to the desired protective field because the alignment of sender and receiver can only be adjusted by a maximum of $\pm 2.5^\circ$ after mounting.

Fig. 16: Composition of the side bracket

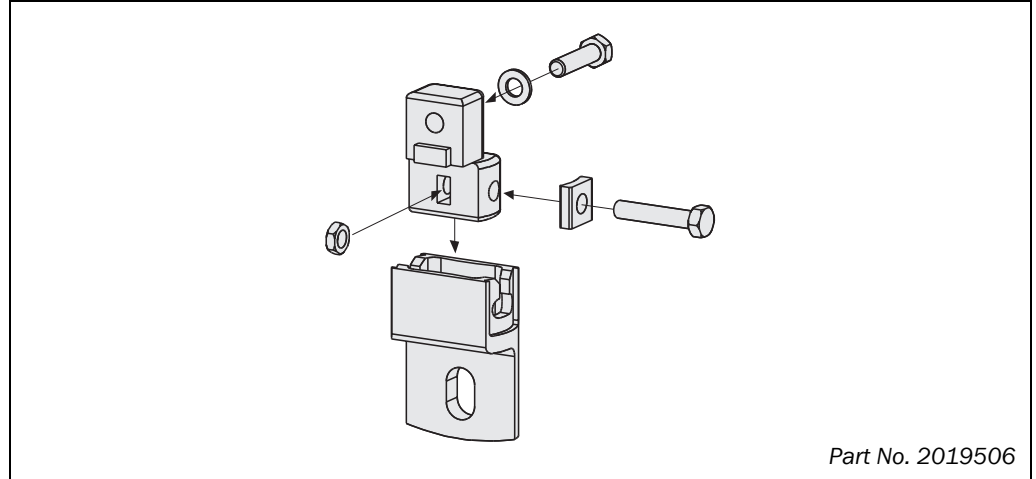

- Notes**
- Attach the bolts of the side bracket with a torque of between 5 and 6 Nm. Higher torques can damage the bracket; lower torques provide inadequate protection against vibration.
 - When mounting the bracket, note the distance and the position of the sliding nuts as described in chapter 10.4 “Dimensional drawings” on page 50f.

Fig. 17: Mounting the C4000 with side bracket

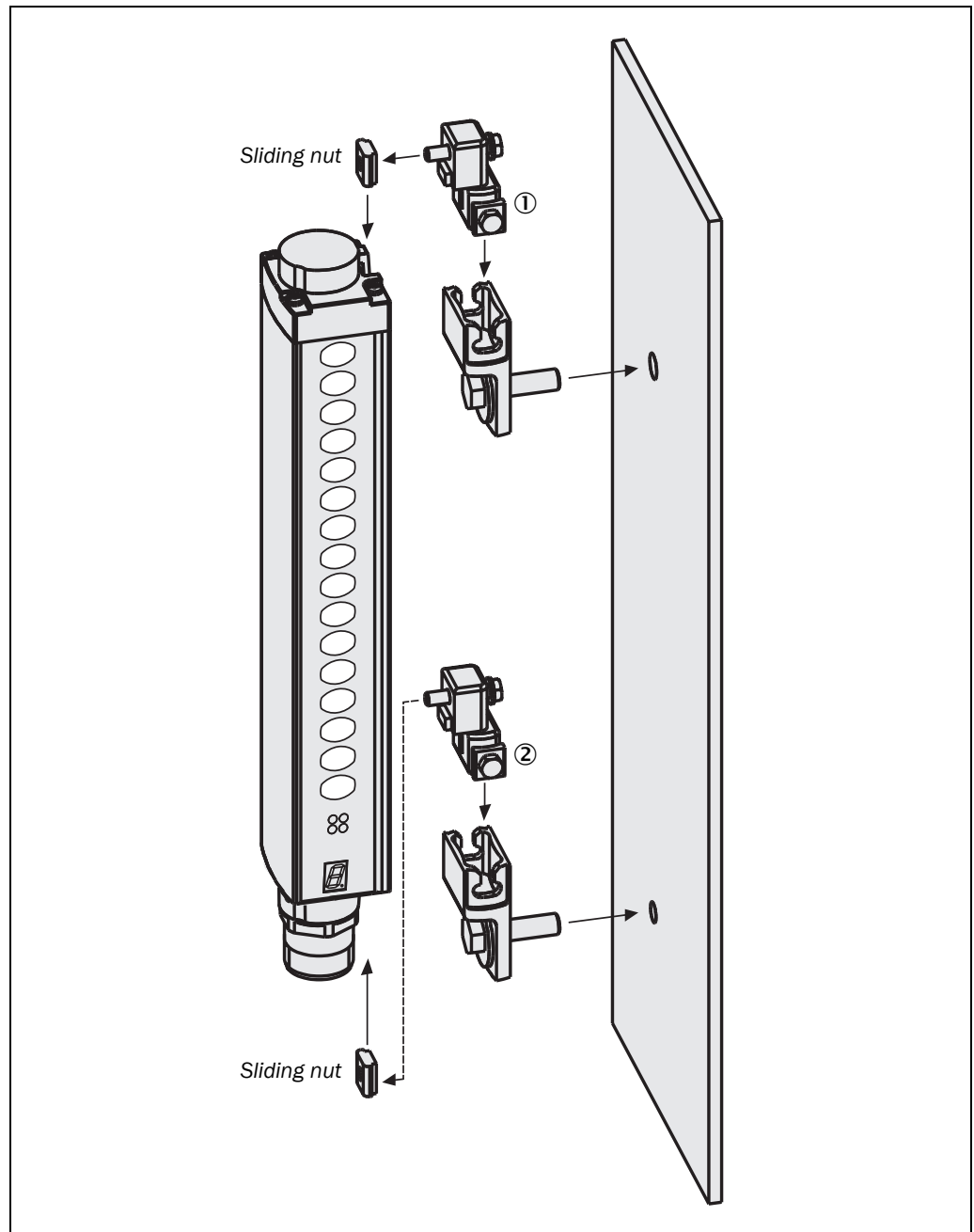

- Notes**
- When mounting the side bracket make sure that the bolts marked ① and ② remain accessible, allowing you later to adjust and lock the light curtain in position.
 - If you wish to use the additional front screen (see “Additional front screen (weld spark guard)” on page 60), make sure that the curved side of the device remains accessible after mounting.

5 Electrical installation



WARNING

Switch the entire machine/system off line!

The machine/system could unintentionally start up while you are connecting the devices.

- Ensure that the entire machine/system is disconnected during the electrical installation.

Ensure that downstream contactors are monitored!

Downstream contactors must be positively guided and monitored (see section 5.4 “External device monitoring (EDM)” on page 32)!

Connect OSSD1 and OSSD2 separately!

You are not allowed to connect OSSD1 and OSSD2 together, otherwise signal safety will not be ensured.

- Ensure that the machine controller processes the two signals separately.

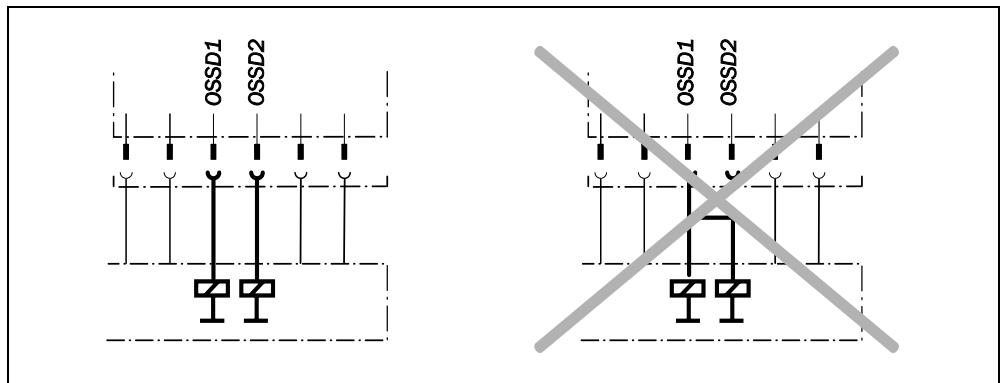

Notes

- The two outputs are protected against short-circuits to 24 V DC and 0 V. When the light path is clear, the signal level on the outputs is HIGH DC (at potential), when the light beams are interrupted or there is a device fault the outputs are LOW DC.
- The safety light curtain C4000 meets the interference suppression requirements (EMC) for industrial use (interference suppression class A). When used in residential areas it can cause interference.
- To ensure full electromagnetic compatibility (EMC), functional earthing (FE) must be connected.
- The external voltage supply of the device must be capable of buffering brief mains voltage failures of 20 ms as specified in EN 60 204-1. Suitable power supplies are available as accessories from SICK (SICK Power Supply 50 W (Part number 7028789)/SICK Power Supply 95 W (Part number 7028790)).

5.1 System connection C4000 Basic (M26 × 6 + FE)

Fig. 18: Pin assignment
system connection
C4000 Basic (M26 × 6 + FE)

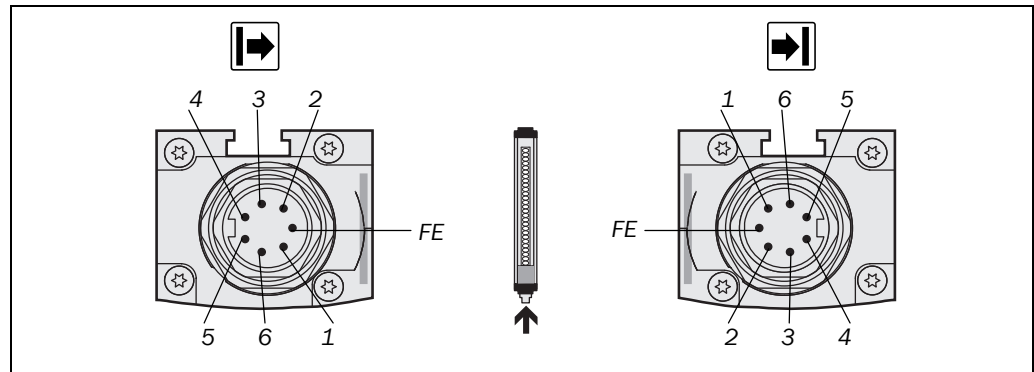

Tab. 9: Pin assignment
system connection
C4000 Basic (M26 × 6 + FE)

Pin	Wire colour	Sender	Receiver
1	brown	24 V DC input (voltage supply)	24 V DC input (voltage supply)
2	blue	0 V DC (voltage supply)	0 V DC (voltage supply)
3	grey	test input: 0 V: external test active 24 V: external test inactive	OSSD1 (switching output 1)
4	pink	reserved	OSSD2 (switching output 2)
5	red	reserved	start-up configuration 1
6	yellow	reserved	external device monitoring (EDM) or start-up configuration 2
FE	green	functional earthing	functional earthing

5.2 System connection C4000 Eco (M12 × 4 + FE)

Fig. 19: Pin assignment
system connection
C4000 Eco (M12 × 4 + FE)

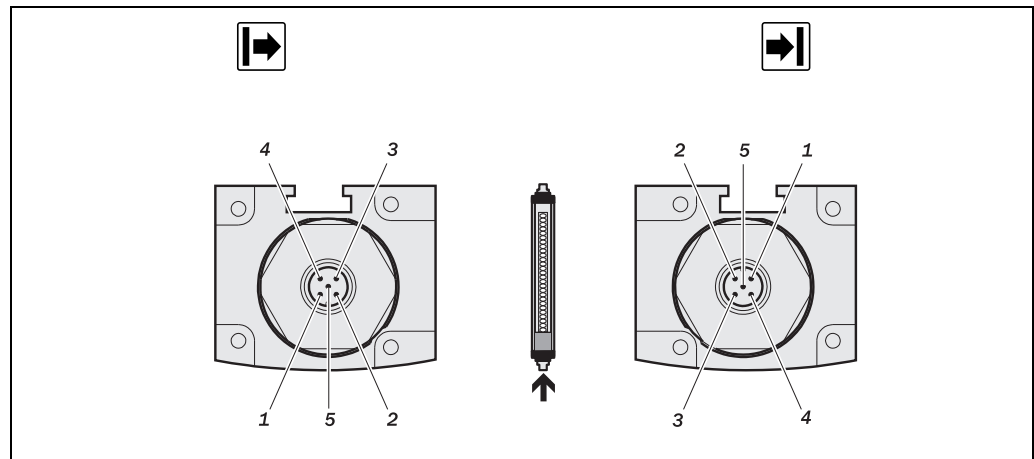

Tab. 10: Pin assignment
system connection
C4000 Eco (M12 × 4 + FE)

Pin	Wire colour	Sender	Receiver
1	brown	24 V DC input (voltage supply)	24 V DC input (voltage supply)
2	white	reserved	OSSD1 (switching output 1)
3	blue	0 V DC (voltage supply)	0 V DC (voltage supply)
4	black	reserved	OSSD2 (switching output 2)
5	grey	functional earthing	functional earthing

5.3 System connection C4000 Micro/Basic Plus (M12 × 7 + FE)

Fig. 20: Pin assignment system connection C4000 Micro/Basic Plus (M12 × 7 + FE)

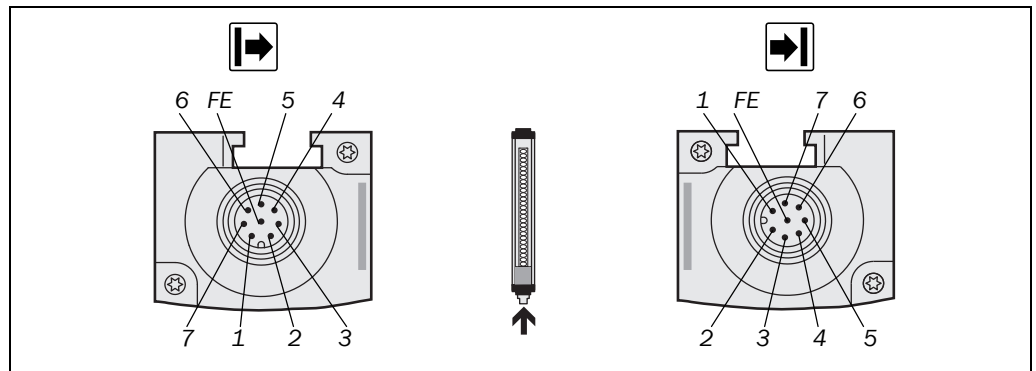

Tab. 11: Pin assignment system connection C4000 Micro/Basic Plus (M12 × 7 + FE)

Pin	Wire colour	Sender	Receiver
1	white	reserved	reset/restart or start-up configuration 2
2	brown	24 V DC input (voltage supply)	24 V DC input (voltage supply)
3	green	reserved	start-up configuration 1 ¹⁾
4	yellow	reserved	external device monitoring (EDM) ¹⁾
5	grey	test input: 0 V: external test active 24 V: external test inactive	OSSD1 (switching output 1)
6	pink	reserved	OSSD2 (switching output 2)
7	blue	0 V DC (voltage supply)	0 V DC (voltage supply)
FE	screen	functional earthing	functional earthing

¹⁾ Pins 3 and 4 of the receiver connection are jumped internally.

5.4 External device monitoring (EDM)

The EDM checks if the contactors actually de-energise when the protective device responds. If, after an attempted reset, the EDM does not detect a response from the switched device within 300 ms, the EDM will deactivate the OSSD switching outputs again.

Fig. 21: Connecting the contact elements to the EDM

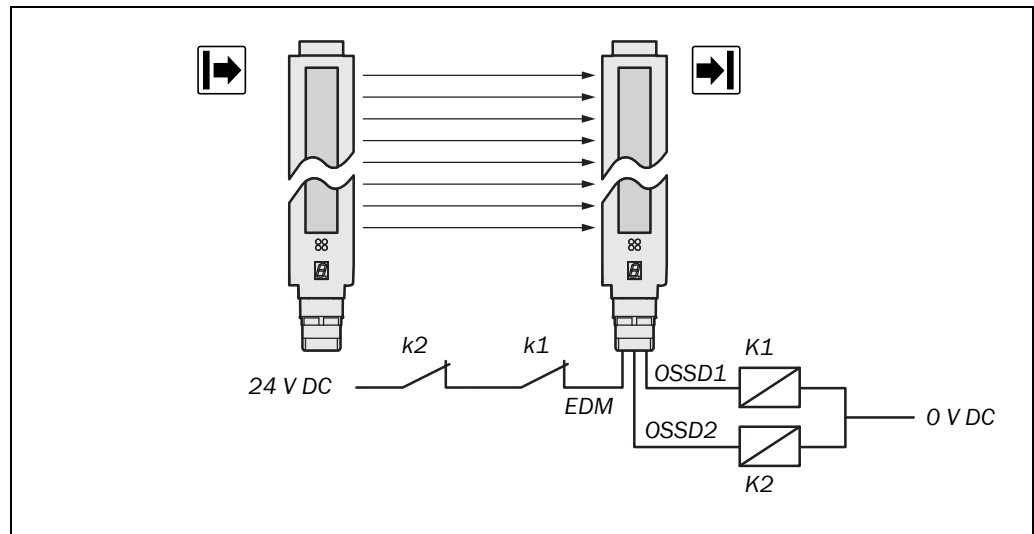

You must implement the external device monitoring electrically by the positive closing action of both N/C contacts (k1, k2) when the contact elements (K1, K2) reach their de-energised position after the protective device has responded. 24 V is then applied at the input of the EDM. If 24 V is not present after the response of the protective device, then one of the contact elements is faulty and the external device monitoring prevents the machine starting up again.

- Notes**
- If the contact elements to be monitored are connected to the external device monitoring (EDM) input, then the safety light curtain activates external device monitoring during the next start-up and saves this configuration in the device.
 - You can again deactivate the external device monitoring at a later time by using the start-up configuration (see section 7.4 “Start-up configuration” on page 39). In this case, pin 6 (C4000 Basic) and pin 4 (C4000 Micro/Basic Plus), respectively, must not be connected to 24 V.

5.5 Reset button

When using C4000 Micro (see section 3.4.1 “Restart interlock” on page 14), the operator must press the reset button prior to restart.

Note If you use the C4000 Micro/Basic without restart interlock, then you must implement the restart interlock externally, i.e. on the machine.



WARNING

Select the correct installation site for the reset button!

Install the reset button outside the hazardous area such that it cannot be operated from inside the hazardous area. When operating the reset button, the operator must have full visual command of the hazardous area.

Fig. 22: Connection of the reset button on the C4000 Micro/Basic

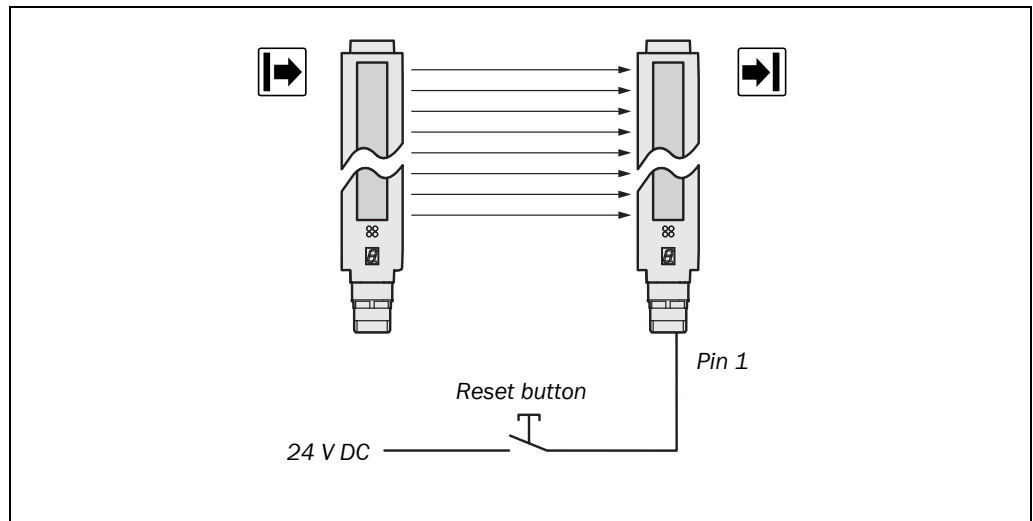

Note You must activate the restart interlock function, otherwise the reset button remains without function during operation. (See chapter 7.2 “Activating the restart interlock” on page 39.)

5.6 Test input (sender test)

Fig. 23: Connection of the sender test button

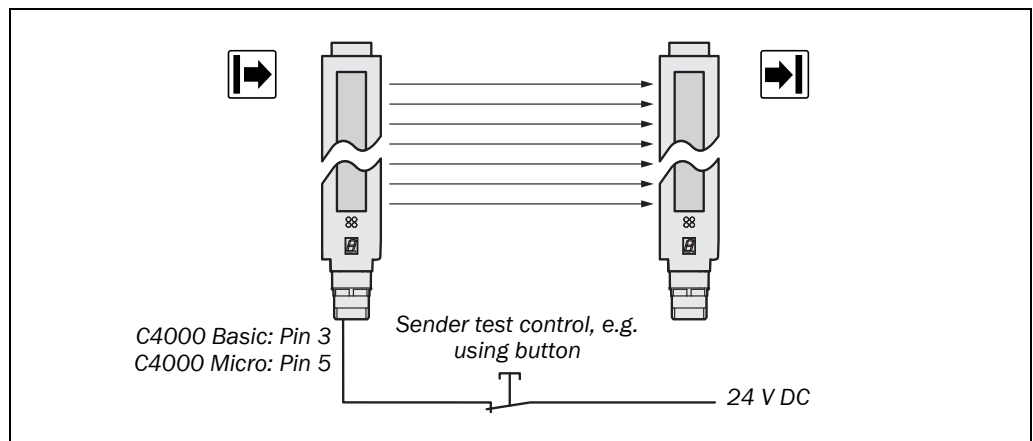

The sender test is performed when 0 V is present at the test input.

5.7 Switching examples

Note Please observe the respective operating instructions of the integrated devices!

5.7.1 C4000 Basic on UE48-20S/UE48-30S with restart interlock and EDM

The C4000 Basic light curtain can be integrated in the switching amplifiers UE48-20S or UE48-30S. Operation is carried out with restart lock and EDM.

Fig. 24: Switching example for C4000 Basic on UE48-20S

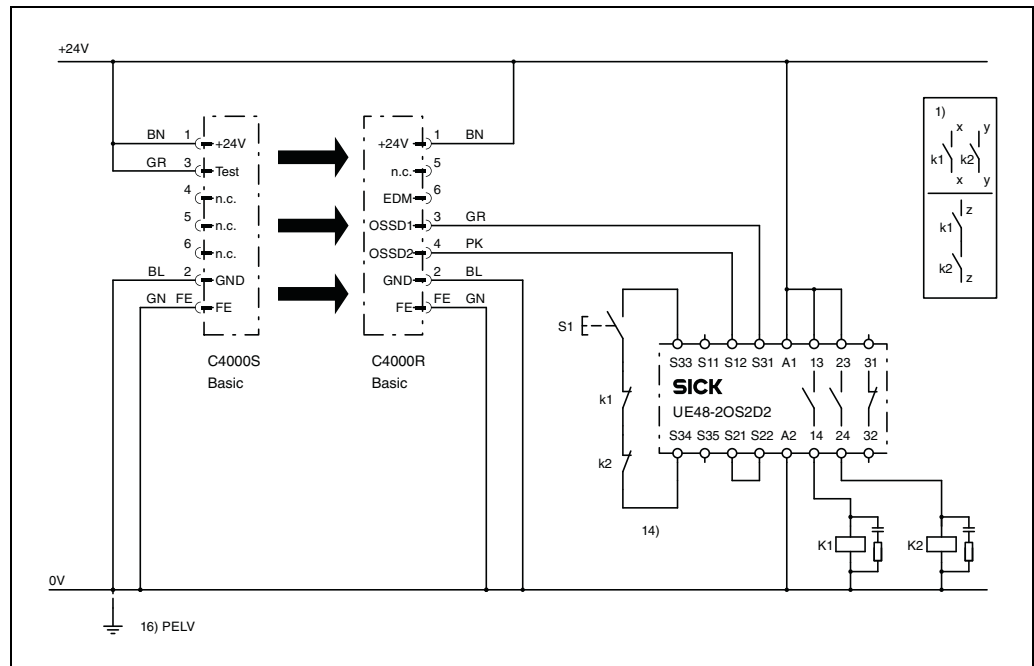

Mode of operation:

If the light path is not interrupted, the outputs OSSD1 and OSSD2 are energised. The system is ready to switch on when K1 and K2 are in the de-energised position. Pressing the button S1 switches on the UE48 switching amplifier. The contacts 13-14 and 23-24 of the UE48 activate the contact elements K1 and K2.

If the light path is interrupted, the outputs OSSD1 and OSSD2 are de-energised. This switches off the UE48 and deactivates K1, K2.

Possible fault sources:

Cross and short-circuiting of the outputs OSSD1 and OSSD2 are detected and lead to a lock-out. Malfunctions of the contact elements K1 and K2 are detected; the switch-off function remains active.

5.7.2 C4000 Micro/Basic on UE10-30S without restart interlock, with EDM

The C4000 Micro/Basic light curtain can be integrated in the UE10-30S switching amplifier. Operation is carried out without a restart interlock but with an EDM.

Fig. 25: Switching example for C4000 Micro/Basic on UE10-30S

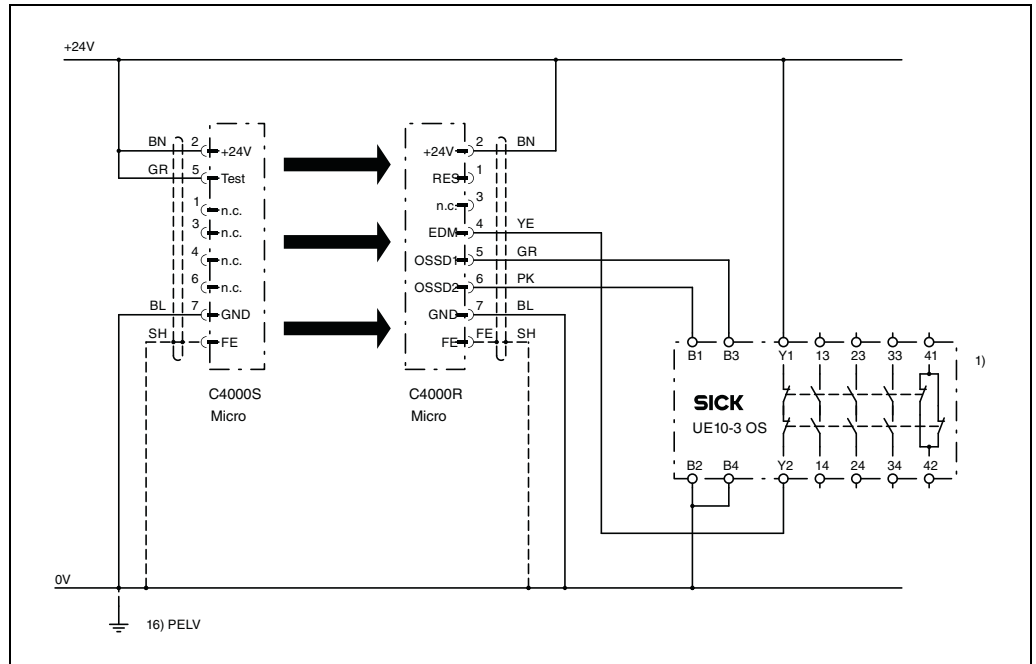

Mode of operation:

If the light path is not interrupted and the UE10 is in the de-energised position, the system is released for use. The outputs OSSD1 and OSSD2 are energised. This switches on the UE10.

If the light path is interrupted, the outputs OSSD1 and OSSD2 are de-energised. This switches off the UE10.

Possible fault sources:

Cross and short-circuiting of the outputs OSSD1 and OSSD2 are detected and lead to a lock-out. Malfunctions of the UE10 are detected; the switch-off function remains active.

6 Commissioning



WARNING

Commissioning requires a thorough check by qualified safety personnel!





Before you operate a system protected by the safety light curtain C4000 for the first time, make sure that the system is first checked and approved by qualified safety personnel. Please read the notes in chapter “On safety” on page 8.

6.1 Display sequence during start-up

After the system is activated, sender and receiver go through a power-up cycle. The 7-segment display indicates the device status during the power-up cycle.

The display values have the following meaning:

Tab. 12: Displays shown during the power-up cycle

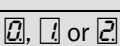
Display	Meaning
	Testing the 7-segment display. All segments are activated sequentially.
	Approx. 0.5 s. Only for systems with a resolution of 14 mm and a scanning range of 1–5 m: Operation with large protective field width
	Approx. 0.5 s. Uncoded operation. This display is due to reasons of compatibility to other C4000 systems.
	Approx. 1 s. Device waits for start-up configuration (see section 7.4 “Start-up configuration” on page 39).
	Receivers only: Receiver-sender alignment incorrect (see “Aligning sender and receiver” below).
Other display	Device error. See “Fault diagnosis” on page 42.

6.2 Aligning sender and receiver

After the light curtain has been mounted and connected, the sender and receiver must be aligned precisely in relation to each other.

How to align sender and receiver in relation to each other:



WARNING



Secure the plant/system. No dangerous movement possible!

Make sure that the dangerous state of the machine is (and remains) switched off! During the alignment process, the outputs of the safety light curtain are not allowed to have any effect on the machine.

- Loosen the clamping bolts which hold the light curtain in place.
- Switch on the power supply to the light curtain.
- Watch the alignment information on the 7-segment display of the receiver (see Tab. 13). Correct the alignment of the sender and receiver, until the 7-segment display goes off.
- Using the clamping bolts, fix the light curtain in place.
- Switch the power supply off and then back on again and check via the 7-segment display whether the alignment is correct after tightening the clamping bolts (Tab. 13).

Tab. 13: Display values during the alignment of sender and receiver

The display values have the following meaning:

Display	Meaning
	The receiver cannot synchronise with the sender; the alignment is very poor.
	Some light beams do not hit the receiver.
	All the light beams hit the receiver, but the alignment is still slightly off.
No display	The alignment is now true; the devices must be locked in this position.

- Notes**
- If the optimum alignment (= no display) persists for longer than 2 minutes without the light beam being interrupted, the system automatically deactivates the alignment mode.
 - If you wish to read just the alignment later, switch the power supply of the C4000 off and back on again.

6.3 Test notes

6.3.1 Tests before the first commissioning

The purpose of the tests before the first commissioning is to confirm the safety requirements specified in the national/international rules and regulations, especially in the Machine and Equipment Usage Directive (EU Conformity).

- Check the effectiveness of the protective device mounted to the machine, using all selectable operating modes as specified in the checklist in the annex (see 12.2 on page 65).
- Make sure that the operating personnel of the machine protected by the safety light curtain are correctly instructed by qualified safety personnel before being allowed to operate the machine. Instructing the operating personnel is the responsibility of the machine owner.
- Annex 12.2 of this document shows a checklist for review by the manufacturer and OEM. Use this checklist as a reference before commissioning the system for the first time.

6.3.2 Regular inspection of the protective device by qualified safety personnel

- Check the system, following the inspection intervals specified in the national rules and regulations. This procedure ensures that any changes on the machine or manipulations of the protective device are detected before use/re-use.
- If any modifications have been made to the machine or the protective device, or if the safety light curtain has been changed or repaired, the system must be checked again as specified in the checklist in the annex.

6.3.3 Daily functional checks of the protective device

The effectiveness of the protective device must be checked daily by a specialist or by authorised personnel, using the correct test rod.

Note Always test along the complete hazardous area to be protected, never solely at the mounting position of the light curtain.

How to check the effectiveness and correct function of the safety light curtain:

- Select the correct test rod depending on device resolution.



WARNING

Do not operate the machine if the green or yellow LED is lit during the test!

If the green or yellow LED lights up *during the test* even for a short period, work must stop at the machine. In this case the installation of the safety light curtain must be checked by qualified safety personnel (see chapter 4).

- Before inserting the test rod, check ...
 - if, for the C4000 Micro or C4000 Basic Plus (M12 x 7+ FE) with de-activated internal restart interlock or the C4000 Basic, the green LED lights up.
 - if, for the C4000 Micro with activated internal restart interlock, the yellow LED flashes ("Reset required").

If this is not the case, make sure that this condition is reached. The test is otherwise meaningless.

- Move the test rod slowly through the protective field to be tested, as shown in ① in Fig. 26.
- Then move the test rod along the edges of the protective field, as shown in ② in Fig. 26. This procedure allows you to test if the point-of-operation guard/reaching behind protection is functioning correctly (see chapter 4.3 "Steps for mounting the device" on page 24).
- If you use one or more deflector mirrors (e.g. PNS), then also guide the test rod slowly through the protective field directly in front of the mirrors.

Note In both tests, the receiver of the C4000 must show the red LED only.

Fig. 26: Daily checks of the protective device

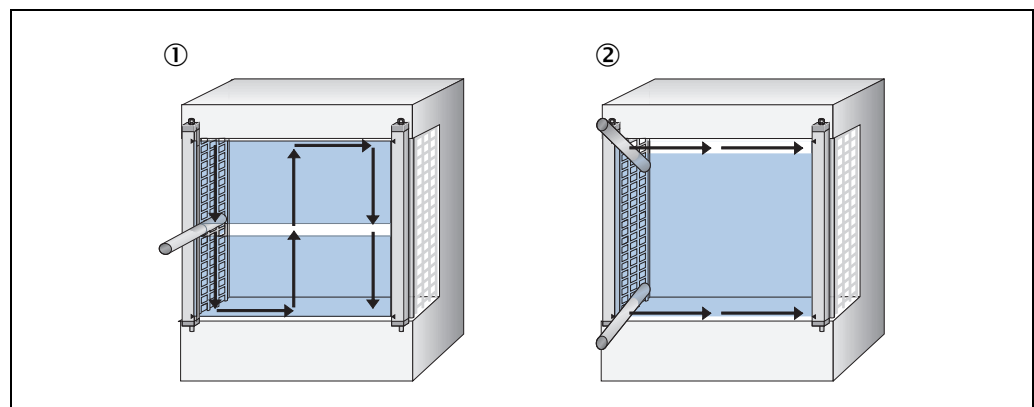

7 Configuration

7.1 Delivery status

The C4000, as supplied, is parameterised ready for protective operation:

- EDM **deactivated**
- Internal restart interlock **deactivated**

7.2 Activating the restart interlock

To activate the restart interlock, a reset button must be connected to the C4000 Micro/Basic (see page 33).

How to activate the internal restart interlock of the C4000 Micro/Basic:



WARNING

Ensure the machine is in a safe condition!

While you configure the safety light curtain, the machine could start unintentionally.

➤ Ensure that the whole system is in a safe condition during the configuration process.

➤ Switch the safety light curtain off.

➤ Keep the reset button pressed.

➤ Switch the safety light curtain on again. The LED ● **Yellow** lights up.

➤ Release the reset button. The LED ● **Yellow** begins to flash.

➤ Press the reset button again within 5 seconds. The safety light curtain now activates the restart interlock function and then immediately operates in protective operation mode.

➤ Ensure that the machine is in a safe condition. Then check the function of the restart interlock. If the restart interlock has not been activated, then repeat the whole process.

Notes The configuration of the restart interlock is permanently saved in the device. The restart interlock can only be deactivated by the start-up configuration (see below).

7.3 Activating external device monitoring

You do not have to activate external device monitoring separately. If the contact elements to be monitored are connected to the external device monitoring (EDM) input, then the safety light curtain activates external device monitoring during the next start-up and saves this configuration in the device.

7.4 Start-up configuration

To avoid unintended configuration changes, the configurable functions of restart interlock and external device monitoring can only be deactivated when switching the system on.

This procedure is only required if you have to change the application or if the safety light curtain is to be used on another machine.

- Notes**
- You can only deactivate the functions of restart interlock and external device monitoring together. If you want to deactivate only one of the two functions then you must, after the start-up configuration, reactivate the respective other function.
 - The start-up configuration requires that the assignment of the unit's inputs be switched over quickly. Ask for the assistance of the electrician responsible, if required.

How to deactivate the restart interlock and external device monitoring:

WARNING

Ensure the machine is in a safe condition!

While you configure the safety light curtain, the machine could start unintentionally.

- Ensure that the whole system is in a safe condition during the configuration process.

Note Only authorised personnel must perform the start-up configuration.

Fig. 27: Time sequence diagram of the start-up configuration
(n. c. = not connected)

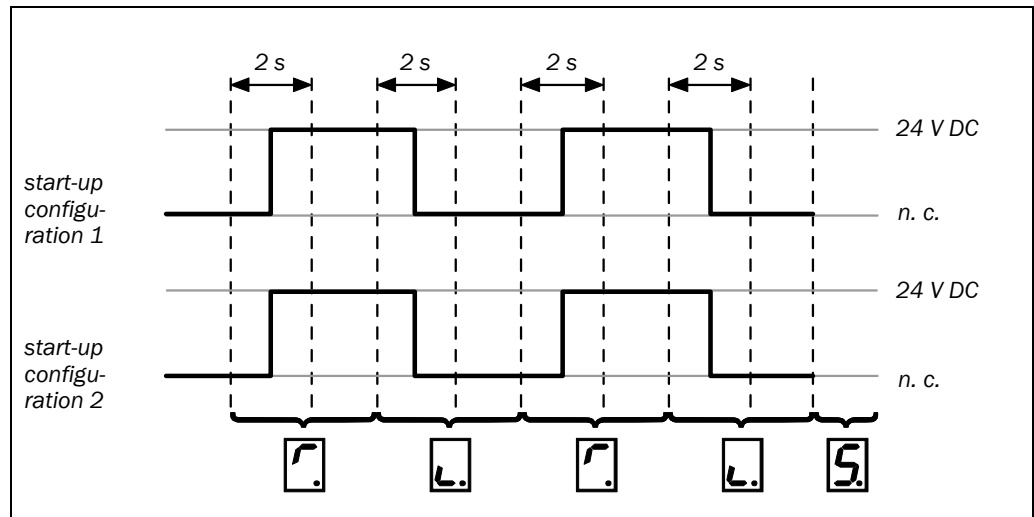

- Switch the safety light curtain off.
- If an EDM is connected, disconnect the wiring.
- Connect the start-up configuration 1 and start-up configuration 2 inputs.
- Switch the safety light curtain on. The 7-segment display shows 1 as confirmation. ①
- Within the next 2 seconds, connect the start-up configuration 1 and start-up configuration 2 inputs with 24 V. The 7-segment display shows 2 as confirmation. ②
- Disconnect the inputs start-up configuration 1 and Switch-on configuration 2 from 24 V within the next 2 seconds. The 7-segment display shows 3 as confirmation. ③
- Once again, connect the start-up configuration 1 and start-up configuration 2 inputs with 24 V, within the next 2 seconds. The 7-segment display shows 4 as confirmation for 2 seconds. ④
- Disconnect the inputs start-up configuration 1 and start-up configuration 2 from 24 V within the next 2 seconds. After successful completion of the start-up configuration, the 7-segment display shows 5. ⑤
- Switch the safety light curtain off.
- Remove the connecting cables of the external device monitoring, if you do not want to use this function any more.
- Switch the safety light curtain on again. External device monitoring and restart interlock are now deactivated.
- Verify the effectiveness of the protective device as described in chapter 6.3 “Test notes” on page 37.

8 Care and maintenance

The safety light curtain C4000 is maintenance-free. The front screen of the safety light curtain C4000 and any additional front screen(s) (see “Additional front screen (weld spark guard)” on page 60) should be cleaned at regular intervals and when dirty.

- Do not use aggressive cleaning agents.
- Do not use abrasive cleaning agents.

Note Static charges cause dust particles to be attracted to the front screen. You can prevent this effect by using the antistatic plastic cleaner (SICK part number 5600006) and the SICK lens cloth (part number 4003353).

How to clean the front screen and/or the additional front screen (optional extra):

- Use a clean and soft brush to remove dust from the front screen.
- Then wipe the front screen with a clean and damp cloth.

Note

- After cleaning, check the position of sender and receiver to make sure that the protective device cannot be bypassed (reaching above, below or stepping behind).
- Verify the effectiveness of the protective device as described in chapter 6.3 “Test notes” on page 37.

9 Fault diagnosis

This chapter describes how to identify and remedy errors and malfunctions during the operation of the safety light curtain.

9.1 What to do in case of faults





WARNING

Cease operation if the cause of the malfunction has not been clearly identified!

Stop the machine if you cannot clearly identify or allocate the error and if you cannot safely remedy the malfunction.

The system state “Lock-out”

In case of certain faults or an erroneous configuration, the system can go into the “Lock-out” state. The 7-segment display on the safety light curtain then indicates ,  or . To place the device back in operation:

- Rectify the cause of the fault as per Tab. 15.
- Switch the power supply for the C4000 off and on again (e.g. by unplugging the system plug and reinserting it).

9.2 SICK Support

If you cannot remedy an error with the help of the information provided in this chapter, please contact your local SICK representative.

9.3 Error displays of the diagnostics LEDs

This chapter explains the meaning of the error displays of the LEDs and how to respond. Please refer to the description in chapter “Status indicators” on page 17.











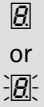



Tab. 14: Error displays of the LEDs

Display	Possible cause	Remedying the error
● Orange LED of receiver lights up	Weak signal	<ul style="list-style-type: none"> ➤ Check the alignment of sender and receiver. ➤ Check the front screen (dirt) and clean, if necessary.
● Yellow LED of receiver flashes	Reset required	<ul style="list-style-type: none"> ➤ Press the reset button.
○ Yellow LED of sender fails to light up	No operating voltage, or voltage too low	<ul style="list-style-type: none"> ➤ Check the voltage supply and activate, if necessary.
○ Red and ○ Green Neither the red nor the green receiver LED lights up		

9.4 Error displays of the 7-segment display

This chapter explains the meaning of the error displays of the 7-segment display and how to respond to the messages. Please refer to section "Status indicators" on page 17 for a description of the 7-segment display.

Tab. 15: Error displays of the 7-segment display

Display	Possible cause	Remedying the error
	Inadequate alignment	<ul style="list-style-type: none"> ➤ Re-align sender and receiver (see page 36). <p>The display extinguishes 2 minutes after the system has been correctly aligned.</p>
	EDM error	<ul style="list-style-type: none"> ➤ Check the contacts and their wiring, eliminate any wiring errors, if necessary. ➤ If  is displayed, switch the device off and back on again.
	Reset button fault	<ul style="list-style-type: none"> ➤ Check the reset button for correct function. The button may be defective or stuck. ➤ Check the wiring of the reset button/for any short-circuit to 24 V.
	System error	<ul style="list-style-type: none"> ➤ Replace the unit (receiver or sender).
	Overcurrent at switching output 1	<ul style="list-style-type: none"> ➤ Check the contactor. Replace, if necessary. ➤ Check the wiring for short-circuit to 0 V.
	Short-circuit at switching output 1	<ul style="list-style-type: none"> ➤ Check the wiring for short-circuit to 24 V.
	Short-circuit at switching output 1	<ul style="list-style-type: none"> ➤ Check the wiring for short-circuit to 0 V.
	Overcurrent at switching output 2	<ul style="list-style-type: none"> ➤ Check the contactor. Replace, if necessary. ➤ Check the wiring for short-circuit to 0 V.
	Short-circuit at switching output 2	<ul style="list-style-type: none"> ➤ Check the wiring for short-circuit to 24 V.
	Short-circuit at switching output 2	<ul style="list-style-type: none"> ➤ Check the wiring for short-circuit to 0 V.
	Short-circuit between switching output 1 and 2	<ul style="list-style-type: none"> ➤ Check the wiring and rectify the error.
	Invalid configuration of the EDM	<ul style="list-style-type: none"> ➤ Verify that the machine-side EDM is connected correctly.
	External sender detected	<ul style="list-style-type: none"> ➤ Check the distance from reflective surfaces (page 22) or from other light curtains. ➤ Swap sender and receiver (inversion of the beam direction) or fit non-reflective partition walls.
	Start-up configuration not successfully completed	<ul style="list-style-type: none"> ➤ Repeat the start-up configuration
	Supply voltage too low	<ul style="list-style-type: none"> ➤ Check the supply voltage and the power supply. If necessary, replace defective components.

10 Technical specifications

10.1 Data sheet

Tab. 16: Technical data
C4000 Basic/Micro/Eco

	minimum	typical	maximum
General system data			
Protective field height, depending on type C4000 Basic/Basic Plus/Eco C4000 Micro	300 mm to 1800 mm 150 mm to 1200 mm		
Resolution, depending on type	14 mm and 30 mm		
Protective field width Resolution 14 mm Resolution 30 mm	0 m 0 m		5 m 6 m
Protection class (IEC 536:1976)	III		
Enclosure rating (IEC 60529)	IP 65		
Supply voltage U_V at device ²⁾	19.2 V	24 V	28.8 V
Residual ripple ³⁾ (SELV)			±10 %
Synchronisation	Optical, without separate synchronisation		
Safety category In compliance with IEC 61496 In compliance with EN 61508	Type 4 SIL 3		
Power-up delay of sender and receiver before ready			8 s

☒ Sender unit

Test input Input voltage ⁴⁾ HIGH (active) Input current HIGH Switching voltage LOW (inactive) Input current LOW ⁴⁾ Response time to test	11 V 7 mA -30 V -3.5 mA	24 V 10 mA 0 V 0 mA	30 V 20 mA 5 V 0.5 mA
	Depending on the number of beams, maximum 150 ms		
Wavelength of sender		950 nm	
Power consumption			0.35 A
Weight	Depending on protective field height (see page 49)		

²⁾ The external voltage supply must be capable of buffering brief mains failures of 20 ms as specified in EN 60204-1. Suitable power supplies are available as accessories from SICK (SICK Power Supply 50 W (Part number 7028789)/SICK Power Supply 95 W (Part number 7028790)).

³⁾ Within the limits of U_V .

⁴⁾ As per IEC 61131-2.

C4000 Micro/Basic/Basic Plus/Eco

Tab. 16: Technical data
C4000 Basic/Micro/Eco
(contd.)

minimum	typical	maximum
---------	---------	---------

Receiver unit

Switching outputs (OSSDs)	2 PNP semiconductor, short-circuit protected ⁵⁾ , cross-circuit monitored		
Response time	See chapter 10.2 on page 48		
Switch off time	100 ms		
Switch on time			2.5 × response time
Switching voltage ⁶⁾ HIGH (active, U _{eff})	15 V	24 V	28.8 V
Switching voltage ⁶⁾ LOW (inactive)	0 V	0 V	3.5 V
Switching current	0 mA		500 mA
Leakage current ⁷⁾			0.25 mA
Load capacity			2.2 μF
Switching sequence	Depending on load inductance		
Load inductance ⁸⁾			2.2 H
Test pulse data ⁹⁾			
Test pulse width	120 μs	150 μs	300 μs
Test pulse rate	3 1/s	5 1/s	10 1/s
Permissible cable resistance			
Between device and load ¹⁰⁾			2.5 Ω
Supply lead			1 Ω
Power consumption			0.45 A + max. 1 A OSSD load

⁵⁾ Applies to the voltage range between -30 V and +30 V.

⁶⁾ As per IEC 61131-2.

⁷⁾ In the case of a fault (0 V cable open circuit) the max. leakage current flows in the OSSD cable. The downstream controller must detect this status as LOW. A safe PLC (Programmable Logic Controller) must be able to identify this status.

⁸⁾ The maximum rated load inductance is higher with lower switching sequence.

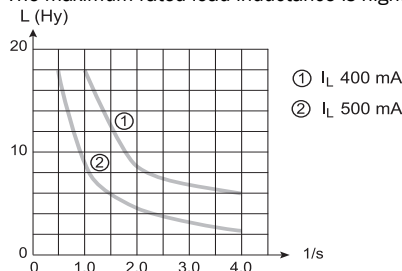

⁹⁾ When active, the outputs are tested cyclically (brief LOW). When selecting the downstream controllers, make sure that the test pulses do not result in deactivation when using the above parameters.

¹⁰⁾ Make sure to limit the individual cable resistance to the downstream controller to this value to ensure that a cross-circuit between the outputs is safely detected. (Also note EN 60 204 Electrical Machine Equipment, Part 1: General Requirements.)

Tab. 16: Technical data
C4000 Basic/Micro/Eco
(contd.)

	minimum	typical	maximum
External device monitoring (EDM) input			
Input voltage ¹¹⁾ HIGH (inactive)	11 V	24 V	30 V
Input current HIGH	6 mA	10 mA	20 mA
Input voltage ¹¹⁾ LOW (active)	-30 V	0 V	5 V
Input current LOW	-2.5 mA	0 mA	0.5 mA
Contactors			
Permissible dropout time			300 ms
Permissible pick-up time			300 ms
Control switch input (reset button)			
Input voltage ¹¹⁾ HIGH (active)	11 V	24 V	30 V
Input current HIGH	6 mA	10 mA	20 mA
Input voltage ¹¹⁾ LOW (inactive)	-30 V	0 V	5 V
Input current LOW	-2.5 mA	0 mA	0.5 mA
Operation time control switch input		110 ms	
Weight	Depending on protective field height (see page 49)		

¹¹⁾ As per IEC 61131-2.

C4000 Micro/Basic/Basic Plus/Eco

Tab. 16: Technical data
C4000 Basic/Micro/Eco
(contd.)

minimum	typical	maximum
---------	---------	---------

Operating data

Connection			
C4000 Basic	M26 × 6 + FE		
C4000 Eco	M12 × 4 + FE		
C4000 Micro/Basic Plus	M12 × 7 + FE		
Line length and cross section ¹²⁾			
C4000 Basic			50 m/0.75 mm ²
C4000 Eco			15 m/0.25 mm ²
C4000 Micro/Basic Plus ¹³⁾			15 m/0.25 mm ²
Ambient operating temperature	0 °C		+55 °C
Air humidity (non-dewing)	15 %		95 %
Storage temperature	-25 °C		+70 °C
Housing cross-section			
C4000 Basic/Basic Plus/Eco	40 mm × 48 mm		
C4000 Micro	28.5 mm × 33.5 mm		
Rigidity	5 g, 10–55 Hz acc. to IEC 60068-2-6		
Shock resistance	10 g, 16 ms acc. to IEC 60068-2-29		

¹²⁾ Dependent on loading, power supply. The technical specifications must be observed.

¹³⁾ If connection cables with large wire cross-section are used, the distance between the devices may be extended. Fig. 13-1 shows obtainable line lengths for M12 connectors when extended with a larger wire cross-section after a cable length of x meters.

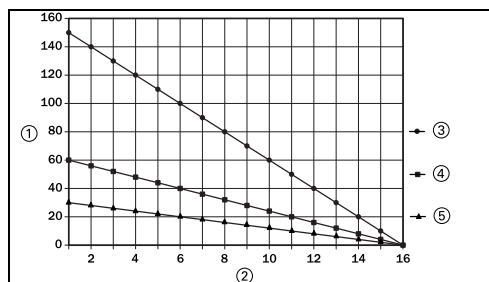

Fig. 13-1: Possible cable lengths for M12 connectors (0.25 mm²) when extended with a larger wire cross-section area cable after x metres

① = Remaining cable length after extension in metres

② = Cable length in metres with a wire cross-section area of 0.25 mm²

③ = Wire cross-section area of 2.5 mm²

④ = Wire cross-section area of 1.0 mm²

⑤ = Wire cross-section area of 0.5 mm²

10.2 Response time

The response time of the C4000 Basic/Micro/Eco is dependent on the number of beams of the system.

How to determine the response time of the system:

➤ Read the response times of the individual systems (shown on type label).

Note If you are planning the application without actually having any devices available, you may also determine the response time using Tab. 17 and Tab. 18:

➤ Read from Tab. 17 the number of beams of the intended system by means of the protective field height and the physical resolution.

➤ Read from Tab. 18 the response time of the system by means of the number of beams.

Tab. 17: Number of beams depending on the protective field height and the physical resolution

Protective field height [mm]	Number of beams for physical resolution	
	14 mm	30 mm
150	20	8
300	40	15
450	60	23
600	80	30
750	100	38
900	120	45
1050	140	53
1200	160	60
1350	180	68
1500	200	75
1650	220	83
1800	240	90

Tab. 18: Response time depending on the number of beams

Number of beams	Response time
10	9 ms
15	10 ms
20	10 ms
23	10 ms
25	10 ms
30	11 ms
35	11 ms
38	11 ms
40	11 ms
45	12 ms
50	12 ms
53	12 ms
55	12 ms
60	13 ms
68	13 ms
75	14 ms

Number of beams	Response time
75	14 ms
80	14 ms
83	14 ms
90	15 ms
100	16 ms
105	16 ms
120	17 ms
135	18 ms
140	19 ms
150	19 ms
160	20 ms
165	20 ms
180	22 ms
200	23 ms
220	24 ms
240	26 ms

10.3 Table of weights**10.3.1 C4000 Basic/Micro/Eco**

Tab. 19: Weight of sender and receiver

Protective field height [mm]	Weight [g] C4000 Basic/Eco		Weight [g] C4000 Micro	
	☒ Sender	☒ Receiver	☒ Sender	☒ Receiver
150	–	–	275	290
300	820	850	370	385
450	1100	1130	510	525
600	1390	1420	650	665
750	1670	1700	795	810
900	1960	1990	940	955
1050	2250	2280	1085	1100
1200	2530	2560	1235	1250
1350	2820	2850	–	–
1500	3110	3140	–	–
1650	3390	3420	–	–
1800	3680	3710	–	–

10.3.2 Deflector mirrors PNS75 and PNS125

Tab. 20: Weight of the deflector mirrors PNS75 and PNS125

Mirror height [mm]	Weight [g]	
	PNS75	PNS125
340	1035	1580
490	1435	2190
640	1850	2820
790	2270	3450
940	2680	4080
1090	3095	4710
1240	3510	5345
1390	3925	5980
1540	4340	6610
1690	4755	7240
1840	5170	7870

10.4 Dimensional drawings

10.4.1 C4000 Basic/Basic Plus/Eco

Fig. 28: Dimensional drawing C4000 Basic/Basic Plus/Eco sender. Receiver mirror image

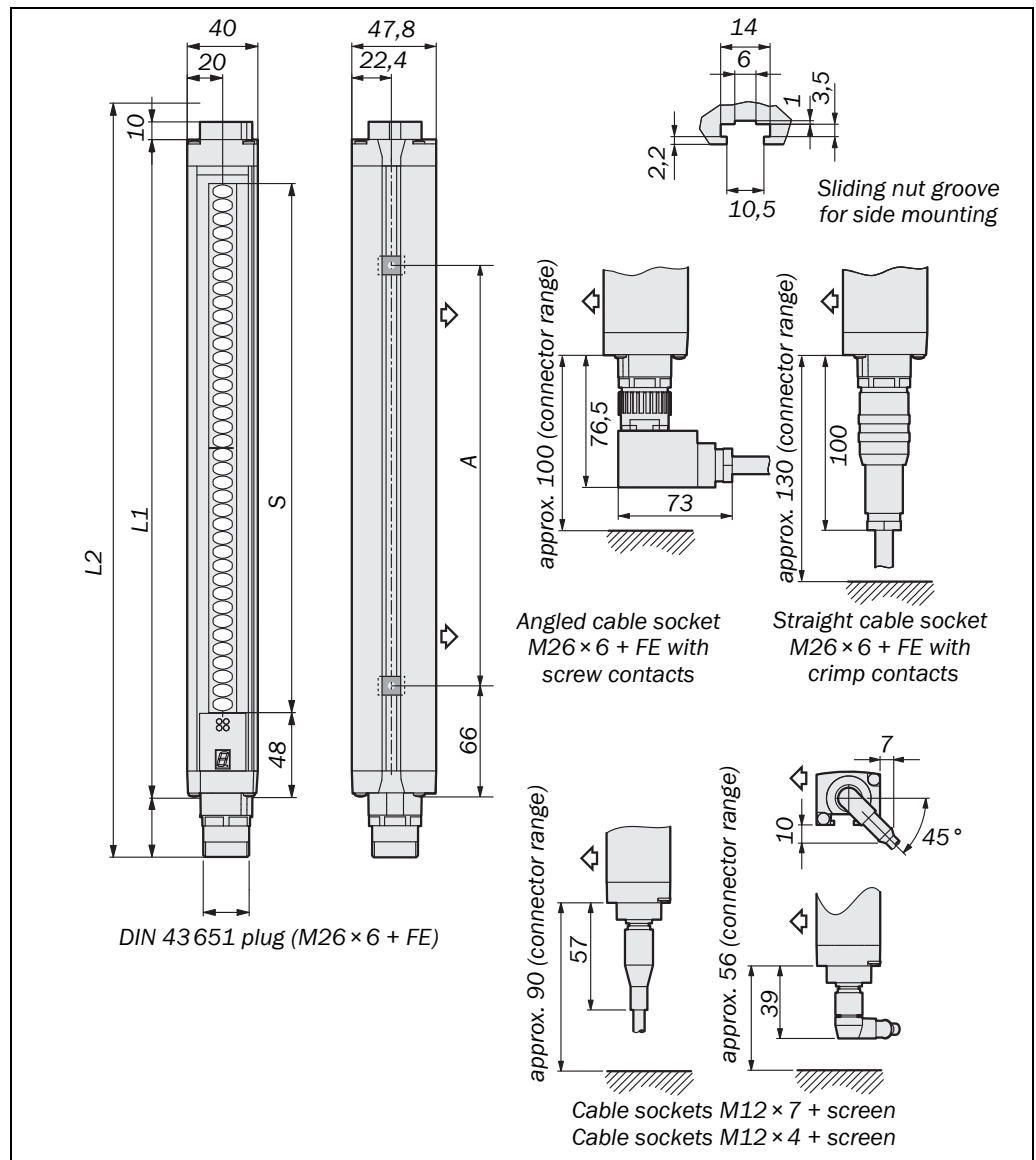

Tab. 21: Dimensions dependent on the protective field height, C4000 Basic/Eco sender

Protective field height S [mm]	Dimension L1 [mm]	Dimension L2 [mm]	Dimension A [mm]
300	372	417	224
450	523	568	374
600	674	718	524
750	824	869	674
900	975	1020	824
1050	1125	1170	974
1200	1274	1319	1124
1350	1426	1471	1274
1500	1577	1622	1424
1650	1727	1772	1574
1800	1878	1923	1724

C4000 Micro/Basic/Basic Plus/Eco

10.4.2 C4000 Micro

Fig. 29: Dimensional drawing C4000 Micro Sender. Receiver, mirror image

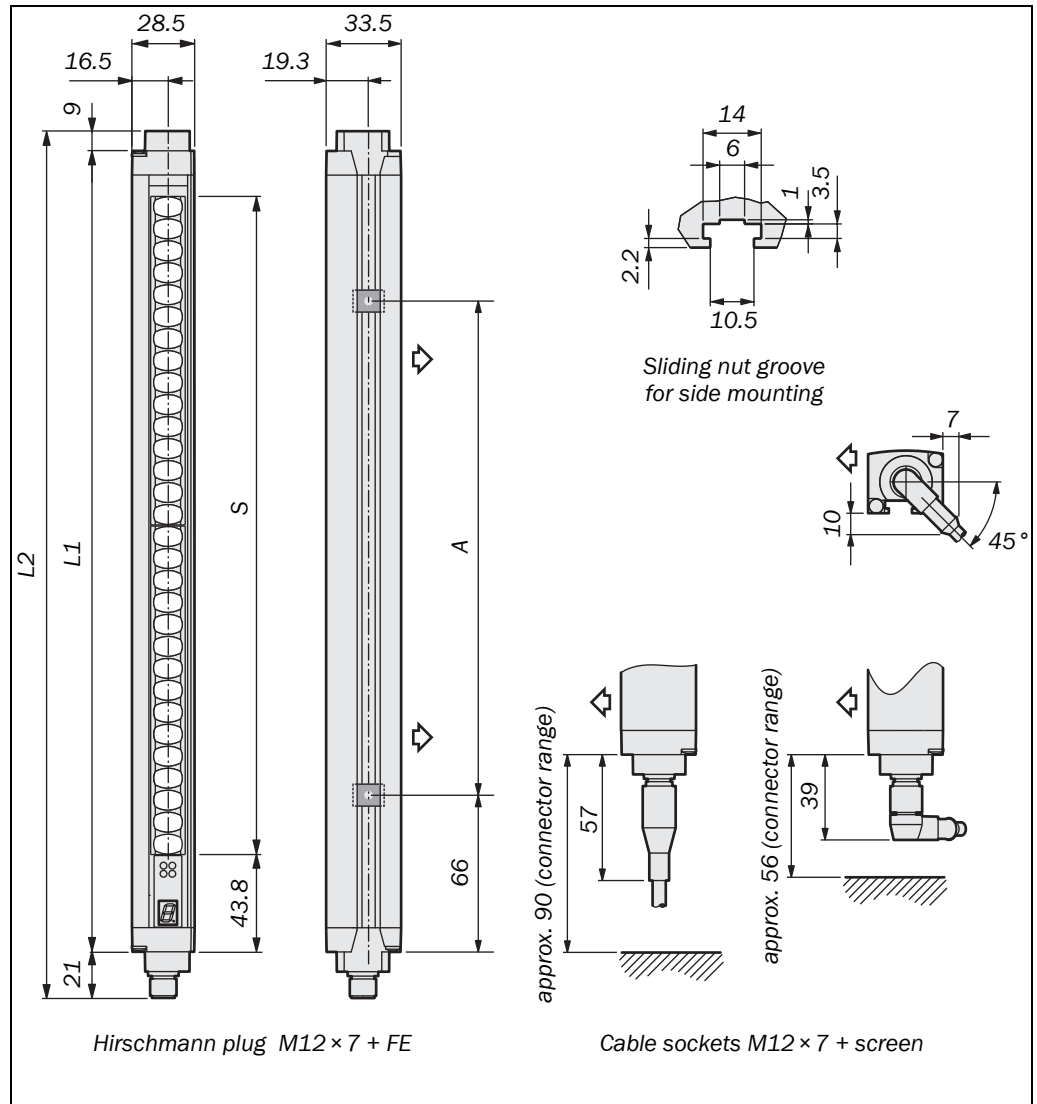

Tab. 22: Dimensions dependent on the protective field height, C4000 Micro sender

Protective field height S [mm]	Dimension L1 [mm]	Dimension L2 [mm]	Dimension A [mm]
150	246	276	106
300	364	394	224
450	515	545	374
600	666	696	524
750	816	846	674
900	967	997	824
1050	1117	1147	974
1200	1266	1296	1124

10.4.3 Swivel mount bracket

Fig. 30: Dimensional drawing swivel mount bracket (mm)

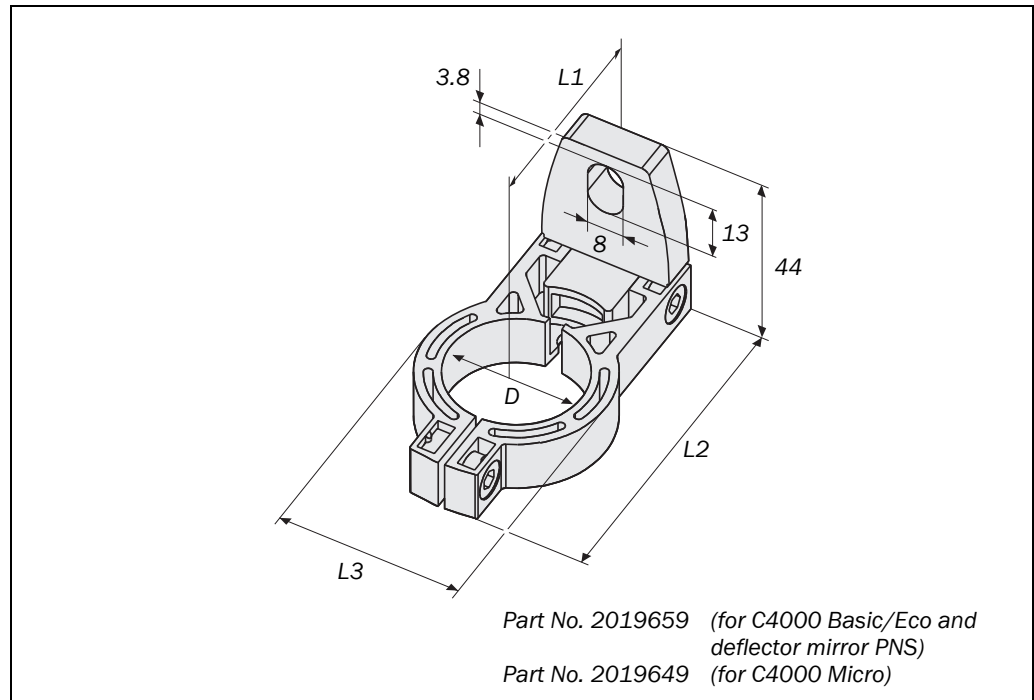

Tab. 23: Dimensions of the swivel mount bracket dependent on the housing profile

Swivel mount for ...	Dimension D [mm]	Dimension L1 [mm]	Dimension L2 [mm]	Dimension L3 [mm]
C4000 Basic/Eco, PNS75 and PNS125	30.6	44.4	75	42
C4000 Micro	24	34.3	62	36

10.4.4 Side bracket

Fig. 31: Dimensional drawing, side bracket (mm)

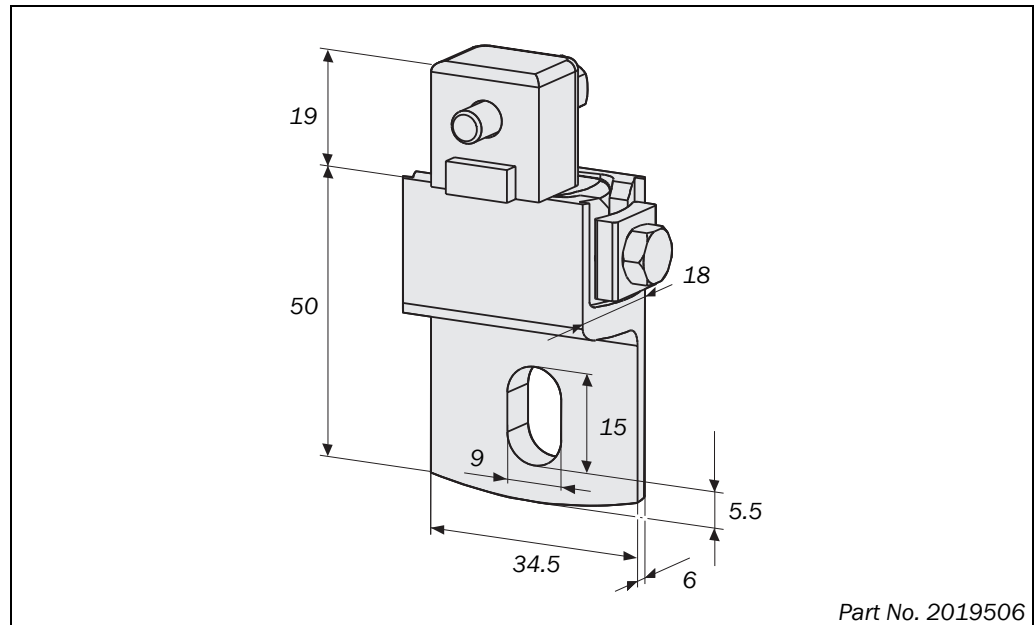

10.4.5 Deflector mirror PNS75

Fig. 32: Dimensional drawing deflector mirror PNS75 (mm)

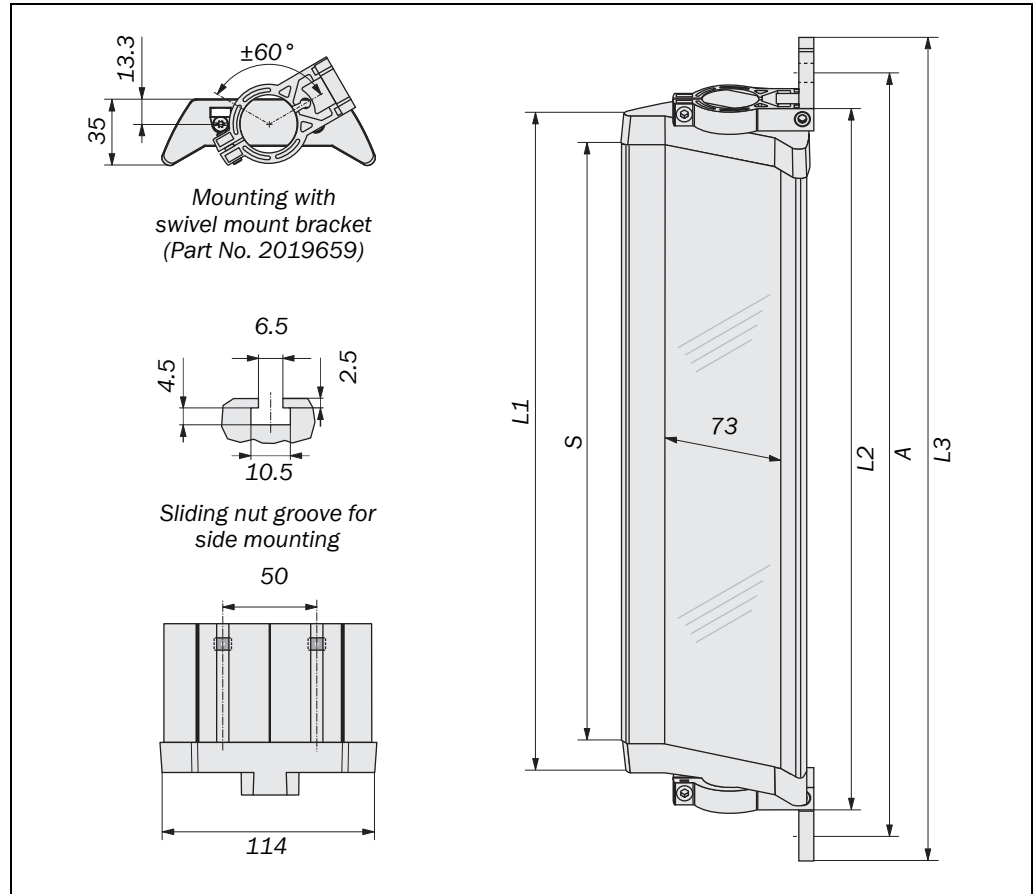

Tab. 24: Dimensions for the deflector mirror PNS75 dependent on the mirror height

Mirror height S [mm]	Dimension L1 [mm]	Dimension L2 [mm]	Dimension L3 [mm]	Dimension A [mm]
340	372	396	460	440
490	522	546	610	590
640	672	696	760	740
790	822	846	910	890
940	972	996	1060	1040
1090	1122	1146	1210	1190
1240	1272	1296	1360	1340
1390	1422	1446	1510	1490
1540	1572	1596	1660	1640
1690	1722	1746	1810	1790
1840	1872	1896	1960	1940

Note When using deflector mirrors, the effective scanning range is reduced (see Tab. 6 on page 16).



WARNING

Do not use deflector mirrors if the formation of droplets or heavy contamination of the deflector mirrors is to be expected!

10.4.6 Deflector mirror PNS125

Fig. 33: Dimensional drawing deflector mirror PNS125 (mm)

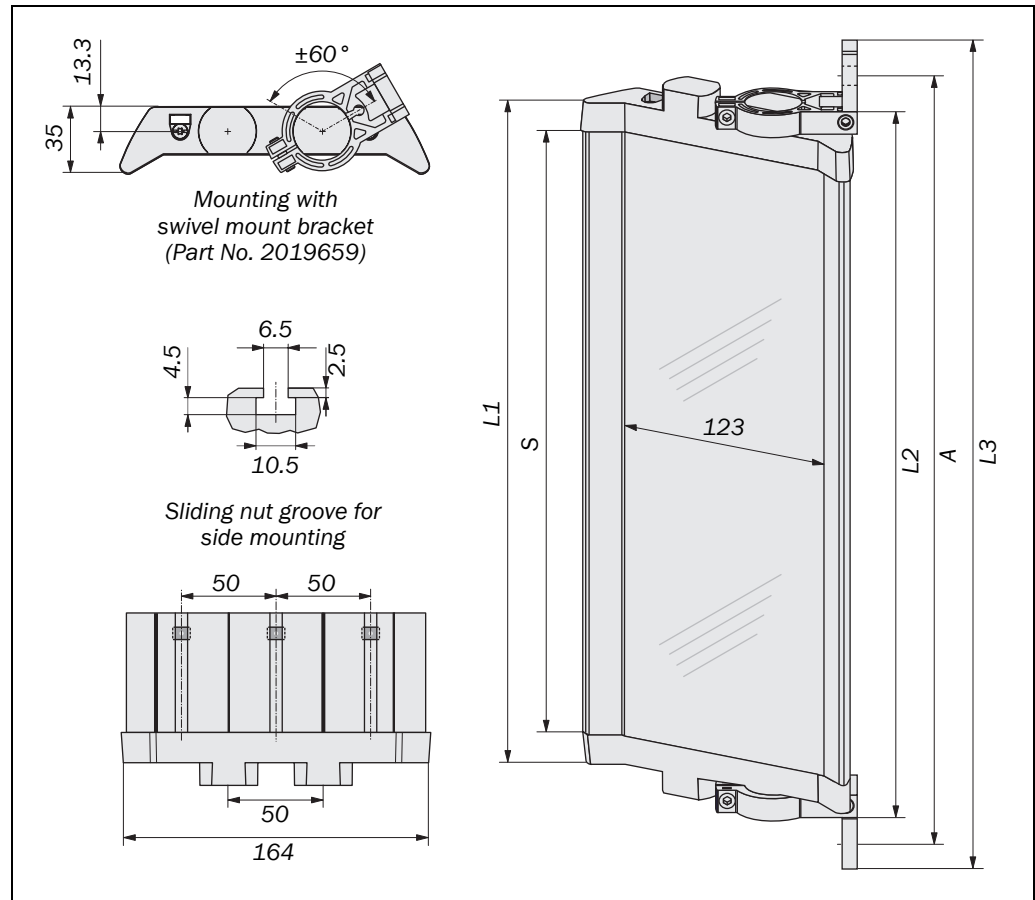

Tab. 25: Dimensions for the deflector mirror PNS125 dependent on the mirror height

Mirror height S [mm]	Dimension L1 [mm]	Dimension L2 [mm]	Dimension L3 [mm]	Dimension A [mm]
340	372	396	460	440
490	522	546	610	590
640	672	696	760	740
790	822	846	910	890
940	972	996	1060	1040
1090	1122	1146	1210	1190
1240	1272	1296	1360	1340
1390	1422	1446	1510	1490
1540	1572	1596	1660	1640
1690	1722	1746	1810	1790
1840	1872	1896	1960	1940

Note When using deflector mirrors, the effective scanning range is reduced (see Tab. 6 on page 16).



WARNING

Do not use deflector mirrors if the formation of droplets or heavy contamination of the deflector mirrors is to be expected!

11 Ordering information

11.1 Delivery

Delivery, sender

- Sender unit
- 4 sliding nuts for side bracket
(C4000 Basic, C4000 Basic Plus, C4000 Eco only)

Delivery, receiver

- Receiver unit
- 4 sliding nuts for side bracket
- Test rod with diameter corresponding to the physical resolution of the safety light curtain
- Information label "Important Information"
- Operating instructions on CD-ROM
- Information label "Operator's notes"

Delivery, deflector mirror

- Deflector mirror
- 2 swivel mount brackets

11.2 C4000 Basic (M26 × 6 + FE)

Tab. 26: Part numbers
C4000 Basic (M26 × 6 + FE)

Protective field height [mm]	Part numbers for resolution and scanning range		
	14 mm	14 mm	30 mm
	0-2.5 m	1-5 m	0-6 m
300	☞ 1022195 (C40S-0301AA030)	☞ 1022195 (C40S-0301AA030)	☞ 1022218 (C40S-0303AA030)
	☞ 1022196 (C40E-0301AH030)	☞ 1022240 (C40E-0301BH030)	☞ 1022219 (C40E-0303AH030)
450	☞ 1022198 (C40S-0401AA030)	☞ 1022198 (C40S-0401AA030)	☞ 1022220 (C40S-0403AA030)
	☞ 1022199 (C40E-0401AH030)	☞ 1022241 (C40E-0401BH030)	☞ 1022221 (C40E-0403AH030)
600	☞ 1022200 (C40S-0601AA030)	☞ 1022200 (C40S-0601AA030)	☞ 1022222 (C40S-0603AA030)
	☞ 1022201 (C40E-0601AH030)	☞ 1022242 (C40E-0601BH030)	☞ 1022223 (C40E-0603AH030)
750	☞ 1022202 (C40S-0701AA030)	☞ 1022202 (C40S-0701AA030)	☞ 1022224 (C40S-0703AA030)
	☞ 1022203 (C40E-0701AH030)	☞ 1022243 (C40E-0701BH030)	☞ 1022225 (C40E-0703AH030)
900	☞ 1022204 (C40S-0901AA030)	☞ 1022204 (C40S-0901AA030)	☞ 1022226 (C40S-0903AA030)
	☞ 1022205 (C40E-0901AH030)	☞ 1022244 (C40E-0901BH030)	☞ 1022227 (C40E-0903AH030)
1050	☞ 1022206 (C40S-1001AA030)	☞ 1022206 (C40S-1001AA030)	☞ 1022228 (C40S-1003AA030)
	☞ 1022207 (C40E-1001AH030)	☞ 1022245 (C40E-1001BH030)	☞ 1022229 (C40E-1003AH030)
1200	☞ 1022208 (C40S-1201AA030)	☞ 1022208 (C40S-1201AA030)	☞ 1022230 (C40S-1203AA030)
	☞ 1022209 (C40E-1201AH030)	☞ 1022246 (C40E-1201BH030)	☞ 1022231 (C40E-1203AH030)
1350	☞ 1022210 (C40S-1301AA030)	☞ 1022210 (C40S-1301AA030)	☞ 1022232 (C40S-1303AA030)
	☞ 1022211 (C40E-1301AH030)	☞ 1022247 (C40E-1301BH030)	☞ 1022233 (C40E-1303AH030)
1500	☞ 1022212 (C40S-1501AA030)	☞ 1022212 (C40S-1501AA030)	☞ 1022234 (C40S-1503AA030)
	☞ 1022213 (C40E-1501AH030)	☞ 1022248 (C40E-1501BH030)	☞ 1022235 (C40E-1503AH030)
1650	☞ 1022214 (C40S-1601AA030)	☞ 1022214 (C40S-1601AA030)	☞ 1022236 (C40S-1603AA030)
	☞ 1022215 (C40E-1601AH030)	☞ 1022249 (C40E-1601BH030)	☞ 1022237 (C40E-1603AH030)
1800	☞ 1022216 (C40S-1801AA030)	☞ 1022216 (C40S-1801AA030)	☞ 1022238 (C40S-1803AA030)
	☞ 1022217 (C40E-1801AH030)	☞ 1022250 (C40E-1801BH030)	☞ 1022239 (C40E-1803AH030)

11.3 C4000 Eco (M12 × 4 + FE)

Tab. 27: Part numbers
C4000 Eco (M12 × 4 + FE)

Protective field height [mm]	Part numbers for resolution and scanning range		
	14 mm	14 mm	30 mm
	0–2,5 m	1–5 m	0–6 m
300	▣ 1027440 (C40S-0301AA310)	▣ 1027440 (C40S-0301AA310)	▣ 1027464 (C40S-0303AA310)
	▣ 1027441 (C40E-0301AN310)	▣ 1027486 (C40E-0301BN310)	▣ 1027465 (C40E-0303AN310)
450	▣ 1027442 (C40S-0401AA310)	▣ 1027442 (C40S-0401AA310)	▣ 1027466 (C40S-0403AA310)
	▣ 1027443 (C40E-0401AN310)	▣ 1027487 (C40E-0401BN310)	▣ 1027467 (C40E-0403AN310)
600	▣ 1027444 (C40S-0601AA310)	▣ 1027444 (C40S-0601AA310)	▣ 1027468 (C40S-0603AA310)
	▣ 1027445 (C40E-0601AN310)	▣ 1027488 (C40E-0601BN310)	▣ 1027469 (C40E-0603AN310)
750	▣ 1027446 (C40S-0701AA310)	▣ 1027446 (C40S-0701AA310)	▣ 1027470 (C40S-0703AA310)
	▣ 1027447 (C40E-0701AN310)	▣ 1027489 (C40E-0701BN310)	▣ 1027471 (C40E-0703AN310)
900	▣ 1027448 (C40S-0901AA310)	▣ 1027448 (C40S-0901AA310)	▣ 1027472 (C40S-0903AA310)
	▣ 1027449 (C40E-0901AN310)	▣ 1027490 (C40E-0901BN310)	▣ 1027473 (C40E-0903AN310)
1050	▣ 1027450 (C40S-1001AA310)	▣ 1027450 (C40S-1001AA310)	▣ 1027474 (C40S-1003AA310)
	▣ 1027451 (C40E-1001AN310)	▣ 1027491 (C40E-1001BN310)	▣ 1027475 (C40E-1003AN310)
1200	▣ 1027452 (C40S-1201AA310)	▣ 1027452 (C40S-1201AA310)	▣ 1027476 (C40S-1203AA310)
	▣ 1027453 (C40E-1201AN310)	▣ 1027492 (C40E-1201BN310)	▣ 1027477 (C40E-1203AN310)
1350	▣ 1027454 (C40S-1301AA310)	▣ 1027454 (C40S-1301AA310)	▣ 1027478 (C40S-1303AA310)
	▣ 1027455 (C40E-1301AN310)	▣ 1027493 (C40E-1301BN310)	▣ 1027479 (C40E-1303AN310)
1500	▣ 1027456 (C40S-1501AA310)	▣ 1027456 (C40S-1501AA310)	▣ 1027480 (C40S-1503AA310)
	▣ 1027457 (C40E-1501AN310)	▣ 1027494 (C40E-1501BN310)	▣ 1027481 (C40E-1503AN310)
1650	▣ 1027458 (C40S-1601AA310)	▣ 1027458 (C40S-1601AA310)	▣ 1027482 (C40S-1603AA310)
	▣ 1027459 (C40E-1601AN310)	▣ 1027495 (C40E-1601BN310)	▣ 1027483 (C40E-1603AN310)
1800	▣ 1027460 (C40S-1801AA310)	▣ 1027460 (C40S-1801AA310)	▣ 1027484 (C40S-1803AA310)
	▣ 1027463 (C40E-1801AN310)	▣ 1027496 (C40E-1801BN310)	▣ 1027485 (C40E-1803AN310)

11.4 C4000 Basic Plus (M12 × 7 + FE)

Tab. 28: Part numbers C4000 Basic Plus (M12 × 7 + FE)

Protective field height [mm]	Part numbers for resolution and scanning range		
	14 mm	14 mm	30 mm
	0–2,5 m	1–5 m	0–6 m
300	▣ 1027922 C40S-0301AA300	▣ 1027922 C40S-0301AA300	▣ 1027933 C40S-0303AA300
	▣ 1027944 C40E-0301AG300	▣ 1027966 C40E-0301BG300	▣ 1027955 C40E-0303AG300
450	▣ 1027923 C40S-0401AA300	▣ 1027923 C40S-0401AA300	▣ 1027934 C40S-0403AA300
	▣ 1027945 C40E-0401AG300	▣ 1027967 C40E-0401BG300	▣ 1027956 C40E-0403AG300
600	▣ 1027924 C40S-0601AA300	▣ 1027924 C40S-0601AA300	▣ 1027935 C40S-0603AA300
	▣ 1027946 C40E-0601AG300	▣ 1027968 C40E-0601BG300	▣ 1027957 C40E-0603AG300
750	▣ 1027925 C40S-0701AA300	▣ 1027925 C40S-0701AA300	▣ 1027936 C40S-0703AA300
	▣ 1027947 C40E-0701AG300	▣ 1027969 C40E-0701BG300	▣ 1027958 C40E-0703AG300
900	▣ 1027926 C40S-0901AA300	▣ 1027926 C40S-0901AA300	▣ 1027937 C40S-0903AA300
	▣ 1027948 C40E-0901AG300	▣ 1027970 C40E-0901BG300	▣ 1027959 C40E-0903AG300
1050	▣ 1027927 C40S-1001AA300	▣ 1027927 C40S-1001AA300	▣ 1027938 C40S-1003AA300
	▣ 1027949 C40E-1001AG300	▣ 1027971 C40E-1001BG300	▣ 1027960 C40E-1003AG300
1200	▣ 1027928 C40S-1201AA300	▣ 1027928 C40S-1201AA300	▣ 1027939 C40S-1203AA300
	▣ 1027950 C40E-1201AG300	▣ 1027972 C40E-1201BG300	▣ 1027961 C40E-1203AG300
1350	▣ 1027929 C40S-1301AA300	▣ 1027929 C40S-1301AA300	▣ 1027940 C40S-1303AA300
	▣ 1027951 C40E-1301AG300	▣ 1027973 C40E-1301BG300	▣ 1027962 C40E-1303AG300
1500	▣ 1027930 C40S-1501AA300	▣ 1027930 C40S-1501AA300	▣ 1027941 C40S-1503AA300
	▣ 1027952 C40E-1501AG300	▣ 1027974 C40E-1501BG300	▣ 1027963 C40E-1503AG300
1650	▣ 1027931 C40S-1601AA300	▣ 1027931 C40S-1601AA300	▣ 1027942 C40S-1603AA300
	▣ 1027953 C40E-1601AG300	▣ 1027975 C40E-1601BG300	▣ 1027964 C40E-1603AG300
1800	▣ 1027932 C40S-1801AA300	▣ 1027932 C40S-1801AA300	▣ 1027943 C40S-1803AA300
	▣ 1027954 C40E-1801AG300	▣ 1027976 C40E-1801BG300	▣ 1027965 C40E-1803AG300

11.5 C4000 Micro

Tab. 29: Part numbers
C4000 Micro

Protective field height [mm]	Part numbers for resolution and scanning range		
	14 mm	14 mm	30 mm
	0-2.5 m	1-5 m	0-6 m
150	☞ 1024054 (C415-0101AA300)	☞ 1024054 (C415-0101AA300)	☞ 1023563 (C415-0103AA300)
	☞ 1024055 (C41E-0101AG300)	☞ 1024037 (C41E-0101BG300)	☞ 1023860 (C41E-0106AG300)
300	☞ 1023458 (C41S-0301AA300)	☞ 1023458 (C41S-0301AA300)	☞ 1023472 (C41S-0303AA300)
	☞ 1023459 (C41E-0301AG300)	☞ 1023486 (C41E-0301BG300)	☞ 1023473 (C41E-0303AG300)
450	☞ 1023460 (C41S-0401AA300)	☞ 1023460 (C41S-0401AA300)	☞ 1023474 (C41S-0403AA300)
	☞ 1023461 (C41E-0401AG300)	☞ 1023487 (C41E-0401BG300)	☞ 1023475 (C41E-0403AG300)
600	☞ 1023462 (C41S-0601AA300)	☞ 1023462 (C41S-0601AA300)	☞ 1023476 (C41S-0603AA300)
	☞ 1023463 (C41E-0601AG300)	☞ 1023488 (C41E-0601BG300)	☞ 1023477 (C41E-0603AG300)
750	☞ 1023464 (C41S-0701AA300)	☞ 1023464 (C41S-0701AA300)	☞ 1023478 (C41S-0703AA300)
	☞ 1023465 (C41E-0701AG300)	☞ 1023489 (C41E-0701BG300)	☞ 1023479 (C41E-0703AG300)
900	☞ 1023466 (C41S-0901AA300)	☞ 1023466 (C41S-0901AA300)	☞ 1023480 (C41S-0903AA300)
	☞ 1023467 (C41E-0901AG300)	☞ 1023490 (C41E-0901BG300)	☞ 1023481 (C41E-0903AG300)
1050	☞ 1023468 (C41S-1001AA300)	☞ 1023468 (C41S-1001AA300)	☞ 1023482 (C41S-1003AA300)
	☞ 1023469 (C41E-1001AG300)	☞ 1023491 (C41E-1001BG300)	☞ 1023483 (C41E-1003AG300)
1200	☞ 1023470 (C41S-1201AA300)	☞ 1023470 (C41S-1201AA300)	☞ 1023484 (C41S-1203AA300)
	☞ 1023471 (C41E-1201AG300)	☞ 1023492 (C41E-1201BG300)	☞ 1023485 (C41E-1203AG300)

11.6 Additional front screen (weld spark guard)

- Notes**
- Two additional front screens (weld spark guards) supplied for each part number.
 - The additional front screen fits both on the sender and on the receiver.
 - The additional front screen may be used only if the curved enclosure side is accessible.
 - An additional front screen reduces the scanning range of the system by 8%. If sender and receiver each use an additional front screen, the scanning range will be reduced by 16%.

Tab. 30: Part numbers, additional front screen (weld spark guard)

Protective field height [mm]	Part number for C4000 Basic	Part number for C4000 Micro
300	2022412	2022405
450	2022413	2022406
600	2022414	2022407
750	2022415	2022408
900	2022416	2022409
1050	2022417	2022410
1200	2022418	2022411
1350	2022419	-
1500	2022420	-
1650	2022421	-
1800	2022422	-

11.7 Deflector mirror

11.7.1 Deflector mirror PNS75 for protective field width 0 ... 5.4 m (total)

Tab. 31: Part numbers,
deflector mirror PNS75

Protective field height [mm]	Type number	Part number
300	PNS75-034	1019414
450	PNS75-049	1019415
600	PNS75-064	1019416
750	PNS75-079	1019417
900	PNS75-094	1019418
1050	PNS75-109	1019419
1200	PNS75-124	1019420
1350	PNS75-139	1019421
1500	PNS75-154	1019422
1650	PNS75-169	1019423
1800	PNS75-184	1019424

Dimensional drawing see Fig. 32 on page 53. Effect on the scanning range see Tab. 6 on page 16.



WARNING

Do not use deflector mirrors if the formation of droplets or heavy contamination of the deflector mirrors is to be expected!

11.7.2 Deflector mirror PNS125 for protective field width 4 ... 5.4 m (total)

Tab. 32: Part numbers,
deflector mirror PNS125

Protective field height [mm]	Type number	Part number
300	PNS125-034	1019425
450	PNS125-049	1019426
600	PNS125-064	1019427
750	PNS125-079	1019428
900	PNS125-094	1019429
1050	PNS125-109	1019430
1200	PNS125-124	1019431
1350	PNS125-139	1019432
1500	PNS125-154	1019433
1650	PNS125-169	1019434
1800	PNS125-184	1019435

Dimensional drawing see Fig. 33 on page 54. Effect on the scanning range see Tab. 6 on page 16.



WARNING

Do not use deflector mirrors if the formation of droplets or heavy contamination of the deflector mirrors is to be expected!

11.8 Accessories

Tab. 33: Part numbers, accessories

Part	Part number
C4000 Basic	
Hirschmann cable socket M26 × 6 + FE, crimp contacts, straight	6006612
Hirschmann cable socket M26 × 6 + FE, screw contacts, angled	6007363
Connection cable	
Socket straight/stripped, 2.5 m	2023993
Socket straight/stripped, 5 m	2023994
Socket straight/stripped, 7.5 m	2023995
Socket straight/stripped, 10 m	2023996
Socket straight/stripped, 15 m	2023997
Socket straight/stripped, 20 m	2023998
Socket straight/stripped, 30 m	2023999
C4000 Micro/Basic Plus	
Connection cable 7 × 0.25 + FE	
Socket straight/stripped, 2.5 m	6020537
Socket straight/stripped, 5 m	6020354
Socket straight/stripped, 7.5 m	6020353
Socket straight/stripped, 10 m	6020352
Socket straight/stripped, 15 m	6020872
Socket angled/stripped, 5 m	6021342
Socket angled/stripped, 15 m	6021343
C4000 Eco	
Cable socket M12 × 7 + FE (max. 0,75 mm ²), straight	6028422
Connection cable 4 × 0.25 + FE	
Socket straight/stripped, 2 m	6008899
Socket straight/stripped, 5 m	6009868
Socket straight/stripped, 10 m	6010544
Socket straight/stripped, 15 m	6029215
Connecting cable (4 x 0.25 + FE) for connection to T-distributor	
Plug straight/socket straight, 0.6 m	6025930
Plug straight/socket straight, 2 m	6025931
T-distributor to connection for connecting cable	6030664
Mounting kit 1 für C4000 Micro and C4000 Basic Plus	
Swivel mount, 4 pcs. for any protective field height	2019649
Mounting kit 2 for C4000 Basic, C4000 Eco and PNS deflector mirror	
Swivel mount, 4 pcs. for any protective field height	2019659
Mounting kit 6	
Swivel function (side bracket), 4 pcs. for any protective field height For higher vibration and shock exposure	2019506

Part	Part number
Laser alignment aid AR60	
Laser alignment aid AR60	1015741
Adapter for AR60, large (is required for C4000 Basic)	4032461
Adapter for AR60, small (is required for C4000 Micro)	4032462
Accessories included in a standard delivery	
Sliding nuts for side bracket, 4 pcs.	2017550
Operating instructions C4000 Micro/Basic/Eco on CD-ROM	2026783
Reset tool	6022103
Adapter cable for reset tool	2026866

12 Annex

12.1 EC Declaration of Conformity

SICK

EC Declaration of Conformity

In Compliance with the of EC Machine Directive 98/37/EC, Appendix VI,
and EMC 89/336/EEC

We hereby declare that the devices

of the product family C4000 basic/micro

are safety components for a machine constructed as per the EC directive 98/37/EC art. 1 para. 2. This declaration will lose its validity if any modification to a device used in the plant is made without prior consultation.

We employ a quality system certified by the DQS (German Quality Assurance Society), No. 462, as per ISO 9001 and have therefore observed the regulations in accordance with module H as well as the following EC directives and EN standards during development and production:

1. EC directives	EC machine directive 98/37/EC			
	EC EMC directive 89/336/EEC as per 92/31/EEC, 93/68/EEC, 93/465/EEC			
2. Harmonized standards used	EN 954-1	Safety-related components of controllers	Ed.	96-12
	EN 50081-2	Emitted interference, industry	Ed.	96-12
	EN 61496-1	Safety of mach., active opto-electronic protective devices (AOPD)	Ed.	97-12
	EN 61496-2	Safety of mach., active opto-electronic protective devices (AOPD)	Ed.	97-11
	EN 61508 Part 2,6,7, Part 1,3,4,5,	Functional safety of electrical/electronic/programmable electronic safety-related systems	Ed.	2000 1998
3. Test result	IEC 61496	BWS type 4		
	IEC 61508	SIL 3		

Conformance of a type sample belonging to the above-mentioned product family with the regulations from the listed EC directive has been certified by:

Address of notified authority (Germany)

TÜV Rheinland Product Safety GmbH
Am Grauen Stein
D-51105 Köln

EC type sample test No

BB 60002313 001 dated 2002-04-11

The CE mark was affixed to the appliance in conformance with directive 89/336/EEC and 93/68/EEC.

Waldkirch/Br., 2002-08-06

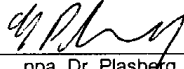
ppa. Dr. Plasberg
(Head of Research & Development
Division Industrial Safety Systems)

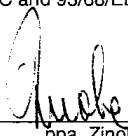
ppa. Zinöber
(Head of Production
Division Industrial Safety Systems)

The declaration certifies conformance with the listed directives, but does not guarantee product characteristics. The safety instructions contained in the product documentation must be observed.

Mat.-Nr.:9 068 420

SICK AG • Sebastian-Kneipp-Straße 1 • D-79183 Waldkirch • Telefon 0 76 81-2 02-0 • Telefax 0 76 81-2 02-38 63 • www.sick.de
Aufsichtsrat: Gisela Sick (Ehrenvorsitzende) • Volker Reiche (Vorsitzender)
Vorstand: Anne-Kathrin Deutrich (Sprecherin) • Dr. Robert Bauer • Jens Höhne (Stellvertr.) • Walter Schmitz
Sitz: Waldkirch i. Br. • Handelsregister: Emmendingen HRB 355 W

12.2 Checklist for the manufacturer

SICK

Checklist for the manufacturer/OEM for the installation of electro-sensitive protective equipment (ESPE)

The details on the items listed below must be available at the latest when the system is commissioned for the first time, depending, however, on the various applications the requirements of which must be reviewed by the manufacturer/OEM.

This checklist should be retained and kept with the machine documentation to serve as reference during recurring tests.

- | | |
|---|--|
| 1. Have the safety rules and regulations been observed in compliance with the directives/standards applicable to the machine? | Yes <input type="checkbox"/> No <input type="checkbox"/> |
| 2. Are the applied directives and standards listed in the declaration of conformity? | Yes <input type="checkbox"/> No <input type="checkbox"/> |
| 3. Does the protective device comply with the required control category? | Yes <input type="checkbox"/> No <input type="checkbox"/> |
| 4. Is the access to the hazardous area/hazardous point only possible through the protective field of the ESPE? | Yes <input type="checkbox"/> No <input type="checkbox"/> |
| 5. Have appropriate measures been taken to prevent (mechanical point-of-operation guarding) or monitor unprotected presence in the hazardous area when protecting a hazardous area/hazardous point and have these been secured against removal? | Yes <input type="checkbox"/> No <input type="checkbox"/> |
| 6. Are additional mechanical protective measures fitted and secured against manipulation which prevent reaching below, above or behind the ESPE? | Yes <input type="checkbox"/> No <input type="checkbox"/> |
| 7. Has the maximum stopping and/or run-down time of the machine been measured, specified and documented (at the machine and/or in the machine documentation)? | Yes <input type="checkbox"/> No <input type="checkbox"/> |
| 8. Has the ESPE been mounted such that the required safety distance from the nearest hazardous point has been achieved? | Yes <input type="checkbox"/> No <input type="checkbox"/> |
| 9. Are the ESPE devices correctly mounted and secured against manipulation after adjustment? | Yes <input type="checkbox"/> No <input type="checkbox"/> |
| 10. Are the required protective measures against electric shock in effect (protection class)? | Yes <input type="checkbox"/> No <input type="checkbox"/> |
| 11. Is the control switch for resetting the protective devices (ESPE) or restarting the machine present and correctly installed? | Yes <input type="checkbox"/> No <input type="checkbox"/> |
| 12. Are the outputs of the ESPE (OSSDs) integrated in compliance with the required control category and does the integration comply with the circuit diagrams? | Yes <input type="checkbox"/> No <input type="checkbox"/> |
| 13. Has the protective function been checked in compliance with the test notes of this documentation? | Yes <input type="checkbox"/> No <input type="checkbox"/> |
| 14. Are the given protective functions effective at every setting of the operating mode selector switch? | Yes <input type="checkbox"/> No <input type="checkbox"/> |
| 15. Are the switching elements activated by the ESPE, e.g. contactors, valves, monitored? | Yes <input type="checkbox"/> No <input type="checkbox"/> |
| 16. Is the ESPE effective over the entire period of the dangerous state? | Yes <input type="checkbox"/> No <input type="checkbox"/> |
| 17. Once initiated, will a dangerous state be stopped when switching the ESPE on or off and when changing the operating mode, or when switching to another protective device? | Yes <input type="checkbox"/> No <input type="checkbox"/> |
| 18. Has the information label "Important Information" for the daily check been attached so that it is well visible for the operator? | Yes <input type="checkbox"/> No <input type="checkbox"/> |

This checklist does not replace the initial commissioning, nor the regular inspection by qualified safety personnel.

12.3 List of tables

Tab. 1:	C4000 Basic model overview.....	11
Tab. 2:	C4000 Micro model overview	11
Tab. 3:	C4000 Eco model overview.....	11
Tab. 4:	Permissible configuration of the restart interlock of the C4000 Micro/Basic	15
Tab. 5:	Scanning range of the C4000 without and with additional front screen.....	16
Tab. 6:	Scanning range when using 1 or 2 deflector mirrors.....	16
Tab. 7:	Status indicators of the sender.....	17
Tab. 8:	Status indicators of the receiver	18
Tab. 9:	Pin assignment system connection C4000 Basic (M26 × 6 + FE)	30
Tab. 10:	Pin assignment system connection C4000 Eco (M12 × 4 + FE)	30
Tab. 11:	Pin assignment system connection C4000 Micro/Basic Plus (M12 × 7 + FE)	31
Tab. 12:	Displays shown during the power-up cycle	36
Tab. 13:	Display values during the alignment of sender and receiver	37
Tab. 14:	Error displays of the LEDs.....	42
Tab. 15:	Error displays of the 7-segment display.....	43
Tab. 16:	Technical data C4000 Basic/Micro/Eco	44
Tab. 17:	Number of beams depending on the protective field height and the physical resolution	48
Tab. 18:	Response time depending on the number of beams	48
Tab. 19:	Weight of sender and receiver	49
Tab. 20:	Weight of the deflector mirrors PNS75 and PNS125	49
Tab. 21:	Dimensions dependent on the protective field height, C4000 Basic/Eco sender.....	50
Tab. 22:	Dimensions dependent on the protective field height, C4000 Micro sender.....	51
Tab. 23:	Dimensions of the swivel mount bracket dependent on the housing profile	52
Tab. 24:	Dimensions for the deflector mirror PNS75 dependent on the mirror height.....	53
Tab. 25:	Dimensions for the deflector mirror PNS125 dependent on the mirror height.....	54
Tab. 26:	Part numbers C4000 Basic (M26 × 6 + FE).....	56
Tab. 27:	Part numbers C4000 Eco (M12 × 4 + FE).....	57
Tab. 28:	Part numbers C4000 Basic Plus (M12 × 7 + FE).....	58
Tab. 29:	Part numbers C4000 Micro.....	59
Tab. 30:	Part numbers, additional front screen (weld spark guard).....	60
Tab. 31:	Part numbers, deflector mirror PNS75	61
Tab. 32:	Part numbers, deflector mirror PNS125.....	61
Tab. 33:	Part numbers, accessories.....	62

12.4 List of illustrations

Fig. 1:	Components of the C4000	12
Fig. 2:	Protecting hazardous points with a safety light curtain C4000.....	13
Fig. 3:	Hazardous area protection with a safety light curtain C4000.....	13
Fig. 4:	Access protection using a safety light curtain C4000.....	13
Fig. 5:	Outline drawing of the protective operation.....	14
Fig. 6:	Status indicators of the sender	17
Fig. 7:	Status indicators of the receiver.....	18
Fig. 8:	Safety distance from the hazardous point.....	20
Fig. 9:	Minimum distance to reflective surfaces.....	22
Fig. 10:	Graph, minimum distance from reflective surfaces	22
Fig. 11:	Unwanted influencing of a 2nd C4000 system.	23
Fig. 12:	Reversing the transmission direction of systems in close proximity.	23
Fig. 13:	The correct installation (above) must eliminate the errors (below) stepping behind, reaching below and reaching above.	24
Fig. 14:	Composition of the swivel mount bracket.....	25
Fig. 15:	Mounting sender and receiver using swivel mount brackets	26
Fig. 16:	Composition of the side bracket.....	27
Fig. 17:	Mounting the C4000 with side bracket.....	28
Fig. 18:	Pin assignment system connection C4000 Basic (M26 × 6 + FE).....	30
Fig. 19:	Pin assignment system connection C4000 Eco (M12 × 4 + FE).....	30
Fig. 20:	Pin assignment system connection C4000 Micro/Basic Plus (M12 × 7 + FE).....	31
Fig. 21:	Connecting the contact elements to the EDM.....	32
Fig. 22:	Connection of the reset button on the C4000 Micro/Basic	33
Fig. 23:	Connection of the sender test button	33
Fig. 24:	Switching example for C4000 Basic on UE48-20S	34
Fig. 25:	Switching example for C4000 Micro/Basic on UE10-30S.....	35
Fig. 26:	Daily checks of the protective device.....	38
Fig. 27:	Time sequence diagram of the start-up configuration	40
Fig. 28:	Dimensional drawing C4000 Basic/Basic Plus/Ecosender.....	50
Fig. 29:	Dimensional drawing C4000 Micro Sender.....	51
Fig. 30:	Dimensional drawing swivel mount bracket (mm)	52
Fig. 31:	Dimensional drawing, side bracket (mm)	52
Fig. 32:	Dimensional drawing deflector mirror PNS75 (mm)	53
Fig. 33:	Dimensional drawing deflector mirror PNS125 (mm).....	54

Australia

Phone +61 3 9497 4100
1800 33 48 02 – tollfree
E-Mail sales@sick.com.au

Belgium/Luxembourg

Phone +32 (0)2 466 55 66
E-Mail info@sick.be

Brasil

Phone +55 11 3215-4900
E-Mail sac@sick.com.br

Ceská Republika

Phone +420 2 57 91 18 50
E-Mail sick@sick.cz

China

Phone +852-2763 6966
E-Mail ghk@sick.com.hk

Danmark

Phone +45 45 82 64 00
E-Mail sick@sick.dk

Deutschland

Phone +49 211 5301-301
E-Mail kundenservice@sick.de

España

Phone +34 93 480 31 00
E-Mail info@sick.es

France

Phone +33 1 64 62 35 00
E-Mail info@sick.fr

Great Britain

Phone +44 (0)1727 831121
E-Mail info@sick.co.uk

India

Phone +91-22-4033 8333
E-Mail info@sick-india.com

Israel

Phone +972-4-999-0590
E-Mail info@sick-sensors.com

Italia

Phone +39 02 27 43 41
E-Mail info@sick.it

Japan

Phone +81 (0)3 3358 1341
E-Mail support@sick.jp

Nederlands

Phone +31 (0)30 229 25 44
E-Mail info@sick.nl

Norge

Phone +47 67 81 50 00
E-Mail austefjord@sick.no

Österreich

Phone +43 (0)22 36 62 28 8-0
E-Mail office@sick.at

Polska

Phone +48 22 837 40 50
E-Mail info@sick.pl

Republic of Korea

Phone +82-2 786 6321/4
E-Mail kang@sickkorea.net

Republika Slovenija

Phone +386 (0)1-47 69 990
E-Mail office@sick.si

România

Phone +40 356 171 120
E-Mail office@sick.ro

Russia

Phone +7 495 775 05 34
E-Mail info@sick-automation.ru

Schweiz

Phone +41 41 619 29 39
E-Mail contact@sick.ch

Singapore

Phone +65 6744 3732
E-Mail admin@sicksgp.com.sg

Suomi

Phone +358-9-25 15 800
E-Mail sick@sick.fi

Sverige

Phone +46 10 110 10 00
E-Mail info@sick.se

Taiwan

Phone +886 2 2375-6288
E-Mail sales@sick.com.tw

Türkiye

Phone +90 216 587 74 00
E-Mail info@sick.com.tr

United Arab Emirates

Phone +971 4 8865 878
E-Mail info@sick.ae

USA/Canada/México

Phone +1(952) 941-6780
1 800-325-7425 – tollfree
E-Mail info@sickusa.com

More representatives and agencies
in all major industrial nations at
www.sick.com