



Main

Range of product	Modicon M168 logic controller
Product or component type	Base controller
Product specific application	For solutions
Variant	Programmable
Communication port protocol	Modbus BACnet IP (optional) BACnet MS/TP (optional)
Input/Output number	23
Input/Output number	2 configurable analog output(s) 1 dedicated PWM output(s) 8 discrete output(s) 5 configurable analog input(s) 7 discrete input(s)

Complementary

Discrete input number	7
Discrete input logic	Sink or source (positive/negative)
Discrete input voltage	24 V
Discrete input voltage type	AC/DC
Sensor power supply	18...36 V DC 4.4...5 V DC
Voltage state 1 guaranteed	> 15 V for discrete input(s)
Voltage state 0 guaranteed	<= 10 V for discrete input(s)
Input impedance	<= 10 kOhm for discrete input(s)
Input frequency	47 Hz...63 kHz for discrete input(s)
Discrete output number	3 (5 mA) 5 (8 mA)
Contacts type and composition	1 C/O for discrete output(s) 7 NO for discrete output(s)
Minimum load	10 mA at 12 V
Discrete output current	5 mA for relay output 8 mA for relay output
Load current	5 A at 24...250 V AC 5 A at 5...30 V DC 8 A at 24...250 V AC 8 A at 5...30 V DC
Mechanical durability	>= 10000000 cycles for relay output
Electrical durability	>= 50000 cycles AC-15 braking current: 5 A at 250 V, 3 A, cos phi = 0.4 >= 300000 cycles AC-12 braking current: 5 A at 250 V, 2.5 A >= 200000 cycles DC-13 braking current: 5 A at 24 V, 1 A, L/R = 48 ms >= 120000 cycles DC-12 braking current: 5 A at 30 V, 2 A >= 6000 cycles AC-15 braking current: 8 A at 250 V, 3 A, cos phi = 0.3 >= 300000 cycles AC-12 braking current: 8 A at 250 V, 2.5 A >= 6000 cycles DC-13 braking current: 8 A at 24 V, 2 A, L/R = 300 ms >= 120000 cycles DC-12 braking current: 8 A at 30 V, 2 A
Operating rate in Hz	<= 0.1 Hz - operating current for discrete output 5 mA <= 20 Hz - off load for discrete output 5 mA <= 0.1 Hz - operating current for discrete output 8 mA <= 10 Hz - off load for discrete output 8 mA
Response time	4 ms on opening for discrete output 5 mA 8 ms on closing for discrete output 5 mA 5 ms on opening for discrete output 8 mA 10 ms on closing for discrete output 8 mA
Analogue input number	5

The information provided in this documentation contains general descriptions and/or technical characteristics of the performance of the products contained herein. This documentation is not intended as a substitute for and is not to be used for determining suitability or reliability of these products for specific user applications. It is the duty of any such user or integrator to perform the appropriate and complete risk analysis, evaluation and testing of the products with respect to the relevant specific application or use thereof. Neither Schneider Electric Industries SAS nor any of its affiliates or subsidiaries shall be responsible or liable for misuse of the information contained herein.

Analogue input type	Temperature probe -100...+200 °C - resolution: 0.5 °C - Pt 1000 probe Temperature probe -50...+150 °C - resolution: 0.1 °C - PTC probe Temperature probe -50...+120 °C - resolution: 0.1 °C - NTC probe Current 0...20 mA/4...20 mA - resolution: 0.01 mA Voltage 0...10 V or 0...5 V ratio - resolution: 0.01 V
Analogue output number	2
Analogue output type	Current 0-20 mA or 4-20 mA - resolution: 0.05 mA Voltage 0...10 V - resolution: 0.01 V
Load impedance ohmic	40...300 Ohm current >= 1000 Ohm voltage
Absolute accuracy error	+/- 0.5 % of full scale for analog input +/- 3 % of full scale for analog output current +/- 2 % of full scale > 5 kOhm for analog output voltage -5 %...+2 % of full scale 1...5 kOhm for analog output voltage
LSB value	0.01 mA for analog input current 5 mV for analog input voltage 0.5 °C for analog input Pt 1000 0.07 °C for analog input NTC 0.02 mA for analog output current 10 mV for analog output voltage
Communication service	Open collector synchro on AC power supply
Protection type	Reverse polarity protection for power supply Overload protection for analog output voltage Reverse polarity protection for analog input voltage
[Us] rated supply voltage	24 V AC 20...40 V DC
Supply voltage limits	20.4...27.6 V
Network frequency	50/60 Hz
Network frequency limits	47...63 Hz
Immunity to microbreaks	10 ms
Power consumption in W	<= 22 W
Power consumption in VA	30 VA at 24 V
Memory capacity	544 kB
Realtime clock	With clock, clock drift <= 30 s/month
Data backed up	Date and hour (internal battery autonomy: 3 days)
Number of port	1 expansion bus terminal blockconnector master/slave 1 Modbus RJ45connector master/slave,transmission rate : 1.2...57.6 kbit/s 1 Modbus RJ45connector slave,transmission rate : 1.2...57.6 kbit/s
Electrical connection	1 removable screw terminal block (3 terminals) for analog output (AO1, AO2, GND) 1 removable screw terminal block (3 terminals) for discrete output (NO8, NC8, COM8) 1 removable screw terminal block (6 terminals) for discrete output (NO4 to NO7, COM 6-7, COM 4-5) 1 removable screw terminal block (5 terminals) for discrete output (NO1 to NO3, COM 1-2, COM 3) 1 removable screw terminal block (2 terminals) for power supply (L+, N/-) 1 removable screw terminal block (5 terminals) for expansion bus (+24 V, GND, CAN-, CAN+) 1 removable screw terminal block (2 terminals) for fan output (FAN+, FAN-) 1 removable screw terminal block (8 terminals) for discrete input (DI1 to DI7, COM) 1 removable screw terminal block (9 terminals) for analog input (AI1 to AI5, GND, +5 V, 24 V)
Cable length	<= 30 m for supply for remote display <= 100 m for no isolated digital input <= 100 m for isolated digital input <= 1000 m for SL2 bus <= 1000 m for SL1 bus <= 1 m for PWM analog output <= 30 m for configurable analog output <= 100 m for relay digital output <= 100 m for analog input <= 100 m for embedded sensor PS <= 30 m for power supply <= 3 m (TTL) for PC programming tool <= 3 m (USB) for PC programming tool <= 1000 m (2 twisted pair cables) for expansion bus
Display type	Without display

Local signalling	1 LED red for user 1 LED red for expansion bus 1 LED red for alarm status 1 LED green for RUN 1 LED green for PWR
Mounting support	35 mm symmetrical DIN rail
Software function	Applicatives functions blocks
Width	251 mm
Height	129.19 mm
Depth	61.5 mm
Product weight	0.723 kg

Environment

Standards	EN/IEC 61000-6-3 EN/IEC 60730-1 EN/IEC 61000-6-1
Product certifications	RoHS REACH UL 60730-1A CSA 60730-1
Marking	CE
Ambient air temperature for operation	-20...65 °C -20...55 °C for UL conformance
Ambient air temperature for storage	-30...70 °C
Relative humidity	5...95 % without condensation
IP degree of protection	IP40 on front face IP20
Pollution degree	2
Overvoltage category	III
Operating altitude	0...2000 m
Storage altitude	0...3048 m
Vibration resistance	1 gn constant amplitude 8.4...150 Hz 3.5 mm constant amplitude 5...< 8.4 Hz
Shock resistance	15 gn for 11 ms

Offer Sustainability

Sustainable offer status	Not Green Premium product
RoHS	Compliant - since 1041 - Schneider Electric declaration of conformity

Controller with Communication Slot

Dimensions

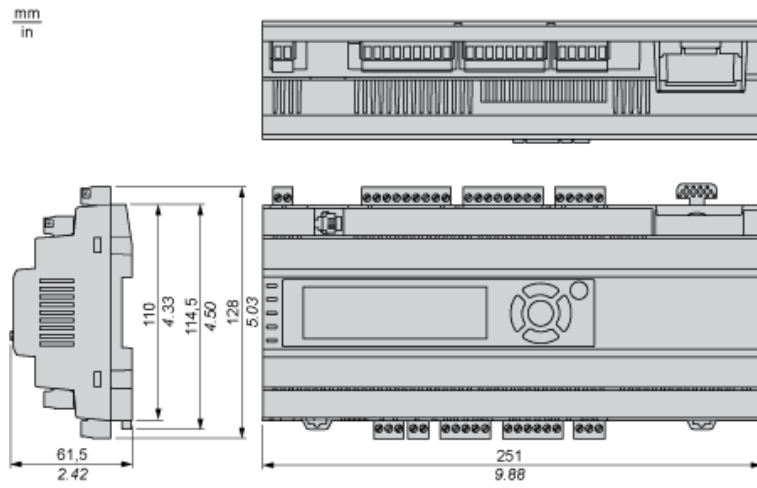

Mounting and Clearance

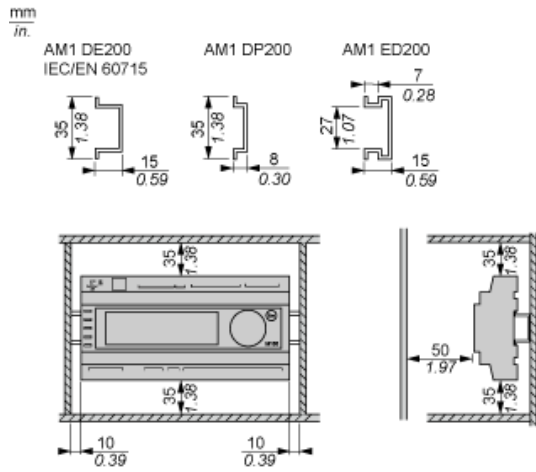

Digital Inputs

Sink/Source Inputs, External Power

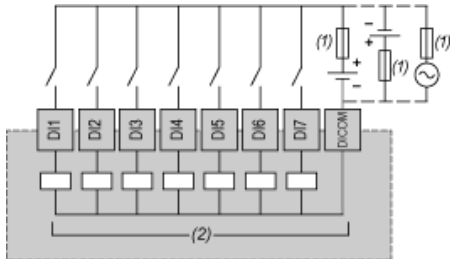

- (1) 0.5 A fast-blow fuse
- (2) Digital inputs

Connection Example for 3-wire PNP Active Switch

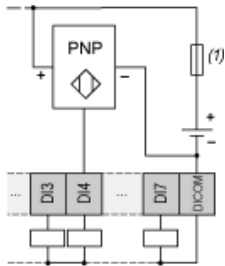

- (1) 0.5 A fast-blow fuse

Connection Example for 3-wire NPN Active Switch

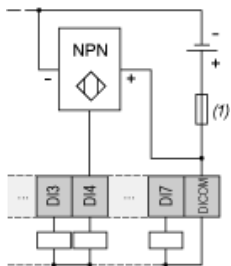

- (1) 0.5 A fast-blow fuse

Analog Inputs

Voltage Mode

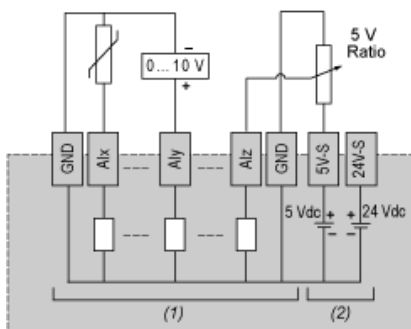

- (1) Analog inputs
- (2) To sensor

Current Mode

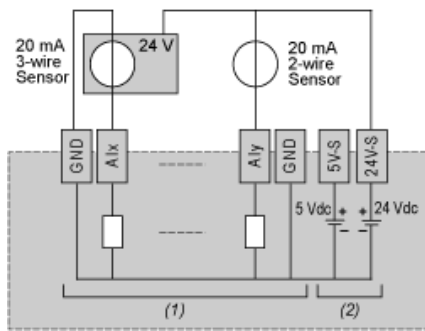

- (1) Analog inputs
- (2) To sensor

Digital Outputs

Wiring Diagram

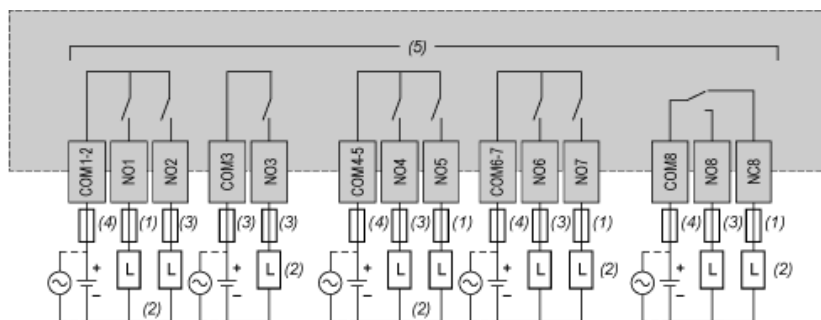

- (1) 5 A Max fuse
- (2) Protection for inductive load
- (3) 8 A Max fuse
- (4) 10 A Max fuse
- (5) Relay outputs

Analog Outputs



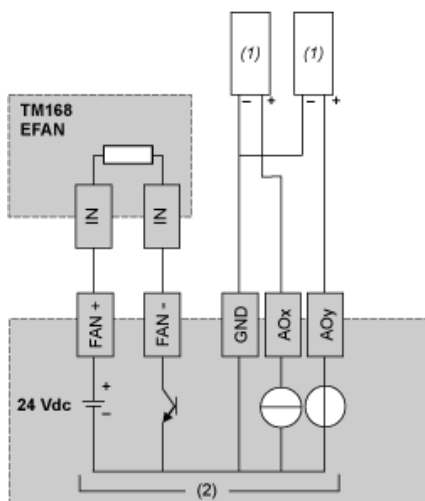

Wiring Diagram



- (1) Voltage/current actuator
- (2) Controller or expansion module analog outputs

Wiring Requirements

Cable Types and Wire Sizes

mm in.				
mm ²	0,08...2,5	0,25...2,5	0,25...1,5	2 x 0,25...2 x 0,75
AWG	28...14	24...14	24...16	2 x 24...2 x 18

Use copper conductors only. Use shielded cables for Modbus.