

Datasheet - AES 2335



Guard door monitors and Safety control modules for Emergency Stop applications / Micro Processor based safety controllers (Series AES) / AES 233x

Preferred typ



- Monitoring of BNS range magnetic safety sensors
- 3 safety contacts, STOP 0
- 2 Signalling outputs

(Minor differences between the printed image and the original product may exist!)

Ordering details

Product type description	AES 2335
Article number	101180843
EAN code	4030661338507

Approval

Approval



Classification

Standards	EN ISO 13849-1, IEC 61508
PL	up d
Control category	up 3
PFH value	1.0 x 10 ⁻⁷ /h
- notice	up to max. 50.000 switching cycles/year and at max. 80% contact load
SIL	up 2
Mission time	20 Years

Global Properties

Product name	AES 233x
Standards	IEC/EN 60204-1, EN 60947-5-1, IEC 60947-5-3, IEC 61508, BG-GS-ET-14, BG-GS-ET-20
Compliance with the Directives (Y/N) 	Yes
Climatic stress	EN 60068-2-3, BG-GS-ET-14
Mounting	snaps onto standard DIN rail to EN 60715
Terminal designations	IEC/EN 60947-1
Materials	
- Material of the housings	Plastic, glass-fibre reinforced thermoplastic
- Material of the contacts	Ag-Ni, 0,2 µm gold flashed
Weight	350 g
Start input (Y/N)	No
Feedback circuit (Y/N)	Yes
Start-up test (Y/N)	No
Reset after disconnection of supply voltage (Y/N)	Yes
Automatic reset function (Y/N)	Yes
Reset with edge detection (Y/N)	No
Pull-in delay	
- ON delay with automatic start	adjustable 0,1 / 1.0 s
Drop-out delay	
- Drop-out delay in case of emergency stop	≤ 30 ms

Mechanical data

Connection type	Screw connection
Cable section	
- Min. Cable section	0,2 mm ²
- Max. Cable section	2.5 mm ²
Pre-wired cable	rigid or flexible
Tightening torque for the terminals	0,6 Nm
Detachable terminals (Y/N)	No
Mechanical life	20.000.000 operations
Electrical lifetime	150.000 operations for 230 VAC, 5 A (cos φ = 1)
Resistance to shock	30 g / 11 ms
Resistance to vibration To EN 60068-2-6	10...55 Hz, Amplitude 0,35 mm, ± 15 %

Ambient conditions

Ambient temperature	
- Min. environmental temperature	0 °C
- Max. environmental temperature	+55 °C
Storage and transport temperature	
- Min. Storage and transport temperature	-25 °C
- Max. Storage and transport temperature	+70 °C
Protection class	
- Protection class-Enclosure	IP40
- Protection class-Terminals	IP20
- Protection class-Clearance	IP54
Air clearances and creepage distances To IEC/EN 60664-1	
- Rated impulse withstand voltage U _{imp}	4.8 kV
- Overvoltage category	III To VDE 0110
- Degree of pollution	2 To VDE 0110

Electromagnetic compatibility (EMC)

EMC rating 10 V/m

Electrical data

Rated DC voltage for controls

- Min. rated DC voltage for controls 20.4 V
- Max. rated DC voltage for controls 253 VDC

Rated AC voltage for controls, 50 Hz

- Min. rated AC voltage for controls, 50 Hz 20.4 VAC
- Max. rated AC voltage for controls, 50 Hz 253 VAC

Rated AC voltage for controls, 60 Hz

- Min. rated AC voltage for controls, 60 Hz 20.4 VAC
- Max. rated AC voltage for controls, 60 Hz 253 VAC

Contact resistance max. 100 mΩ

Power consumption 5 W

Type of actuation DC

Switch frequency 3 Hz

Rated insulation voltage U_i 250 V

Rated operating voltage U_e 24 ... 230 VAC/DC

Thermal test current I_{the} 6 A

Operating current I_e 0,3 A

Electronic protection (Y/N) No

Inputs

Monitored inputs

- Short-circuit recognition (Y/N) Yes
- Wire breakage detection (Y/N) Yes
- Earth connection detection (Y/N) No

Number of shutters adjustable 1 piece -> 0 piece

Number of openers adjustable 1 piece -> 2 piece

Input resistance approx. 4000 Ω at GND

Input signal "1" 10 ... 30 VDC

Input signal "0" 0 ... 2 VDC

Cable length 1000 m with 0,75 mm² (for Rated voltage)

Outputs

Stop category 0

Number of safety contacts 3 piece

Number of auxiliary contacts 0 piece

Number of signalling outputs 2 piece

Switching capacity

- Switching capacity of the safety contacts min. 10 mA, max. 6 A
- Switching capacity of the signaling/diagnostic outputs Y1, Y2: max. 100 mA

Fuse rating

- Protection of the safety contacts 6 A gG D-fuse
- Fuse rating for the signaling/diagnostic outputs short-circuit proof

Signalling output Y1: (X5 / X6 without bridge) Authorized operation (X5 / X6 with bridge) guard open
Y2: (X5 / X6 without bridge) None Authorized operation (X5 / X6 with bridge) Error

Utilisation category To EN 60947-5-1 AC-15: 230 V / 3 A

DC-13: 24 V / 2 A

Number of undelayed semi-conductor outputs with signaling function	2 piece
Number of undelayed outputs with signaling function (with contact)	0 piece
Number of delayed semi-conductor outputs with signaling function.	0 piece
Number of delayed outputs with signalling function (with contact).	0 piece
Number of secure undelayed semi-conductor outputs with signaling function	0 piece
Number of secure, undelayed outputs with signaling function, with contact.	0 piece
Number of secure, delayed semi-conductor outputs with signaling function	0 piece
Number of secure, delayed outputs with signaling function (with contact).	0 piece

LED switching conditions display

LED switching conditions display (Y/N)	Yes
Number of LED's	1 piece

Integral system diagnosis ISD

Integral system diagnosis ISD

- The following faults are registered by the safety monitoring modules and indicated by ISD
- Failure of door contacts to open or close
- Cross-wire or short-circuit monitoring of the switch connections
- Interruption of the switch connections
- Failure of the safety relay to pull-in or drop-out
- Fault on the input circuits or the relay control circuits of the safety monitoring module
- Failure of or functional fault on the safety relay

Miscellaneous data

Applications



Safety sensor



Guard system

Dimensions

Dimensions

- | | |
|----------|--------|
| - Width | 45 mm |
| - Height | 100 mm |
| - Depth | 121 mm |

notice

Inductive loads (e.g. contactors, relays, etc.) are to be suppressed by means of a suitable circuit.

notice - Wiring example

To secure a guard door up to PL 3 and Category #03#

Monitoring a guard door using zwei position switches with safety function.

The NC contact A must have positive break when the guard door is opened.

Category 3 to EN 954-1 can also be achieved using only one safety switch with one NO and one NC contact. Exclusion of faults due to breakage or loosening of the actuating element or the actuating head as well as releasing, dismantling.

The feedback circuit monitors the positions of the positive-guided NC contacts on the conactors K3 and K4.

Start push button A start push button (NO) can optionally be connected into the feedback circuit. With the guard door closed, the enabling paths are then not closed until the start push button has been operated.

If neither start button nor feedback circuit are connected, a jumper connection must be mounted between X1 and X2.

Modification for 2 NC contacts:

The safety monitoring module can be modified to monitor two NC contacts by bridging the terminals X3 and X4. The short-circuit recognition between connections then becomes inoperative.

Inversion of the output function:

By establishing a bridge between X5 and X6, the output function of the additional outputs can be altered. This control can also be realised when e.g. a PLC is running (24 VDC at terminal X6).

Expansion of the enable delay time

The enable delay time can be increased from 0,1 s to 1 s by mounting a jumper connection between the terminals X7 and X8.

The wiring diagram is shown with guard doors closed and in de-energised condition.

The ISD tables (Integral System Diagnostics) for analysis of the fault indications and their causes are shown in the appendix.

Documents

Operating instructions and Declaration of conformity (pl) 222 kB, 28.08.2013

Code: mrl_aes_2335_2336_pl

Operating instructions and Declaration of conformity (es) 242 kB, 11.09.2012

Code: mrl_aes_2335_2336_es

Operating instructions and Declaration of conformity (fr) 243 kB, 28.02.2012

Code: mrl_aes_2335_2336_fr

Operating instructions and Declaration of conformity (en) 238 kB, 18.01.2012

Code: mrl_aes_2335_2336_en

Operating instructions and Declaration of conformity (de) 242 kB, 23.12.2011

Code: mrl_aes_2335_2336_de

Operating instructions and Declaration of conformity (jp) 344 kB, 28.02.2012

Code: mrl_aes_2335_2336_jp

Operating instructions and Declaration of conformity (nl) 235 kB, 06.11.2012

Code: mrl_aes_2335_2336_nl

Operating instructions and Declaration of conformity (da) 220 kB, 11.07.2013

Code: mrl_aes_2335_2336_da

Operating instructions and Declaration of conformity (it) 242 kB, 28.02.2012

Code: mrl_aes_2335_2336_it

Operating instructions and Declaration of conformity (pt) 220 kB, 11.07.2013

Code: mrl_aes_2335_2336_pt

Wiring example (99) 22 kB, 22.08.2008

Code: KAES2L06

Wiring example (99) 21 kB, 22.08.2008

Code: KAES2L05

Wiring example (99) 19 kB, 22.08.2008

Code: kaes2l10

Wiring example (99) 20 kB, 22.08.2008

Code: kaes2l07

Wiring example (99) 22 kB, 22.08.2008

Code: Kaes2l01

ISD tables (Integral System Diagnostics) (en) 35 kB, 29.07.2008

Code: i_ae3p02

ISD tables (Integral System Diagnostics) (de) 53 kB, 29.07.2008

Code: i_ae3p01

BG-test certificate (de) 161 kB, 11.06.2012

Code: z_2aep01

BG-test certificate (en) 178 kB, 03.11.2011

Code: z_a21p02

BG-test certificate (en) 163 kB, 11.06.2012

Code: z_2aep02

BG-test certificate (de) 176 kB, 03.11.2011

Code: z_a21p01

Images

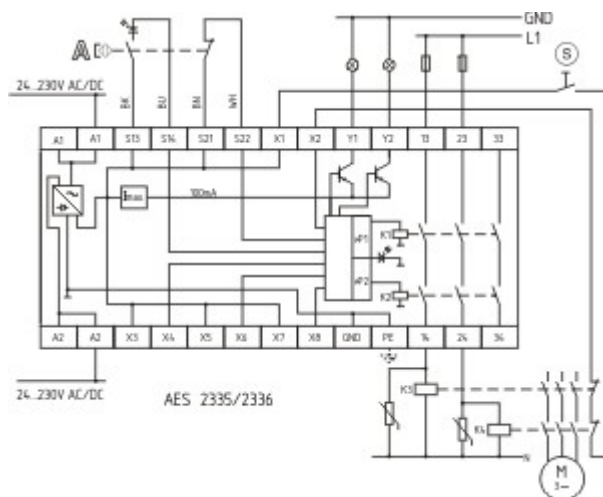

Wiring example

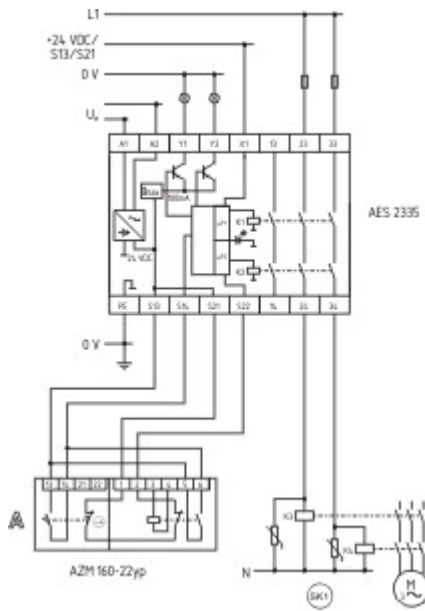

Wiring example

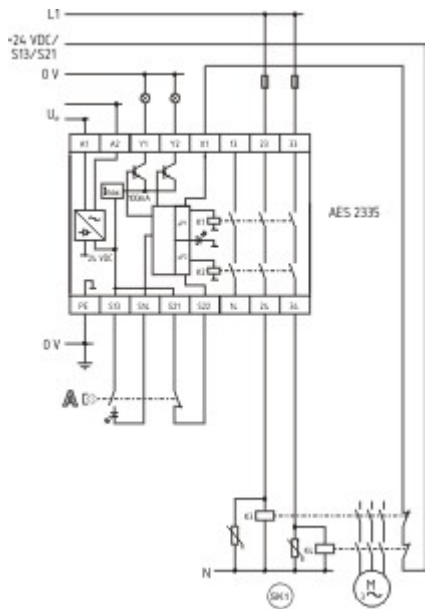

Wiring example

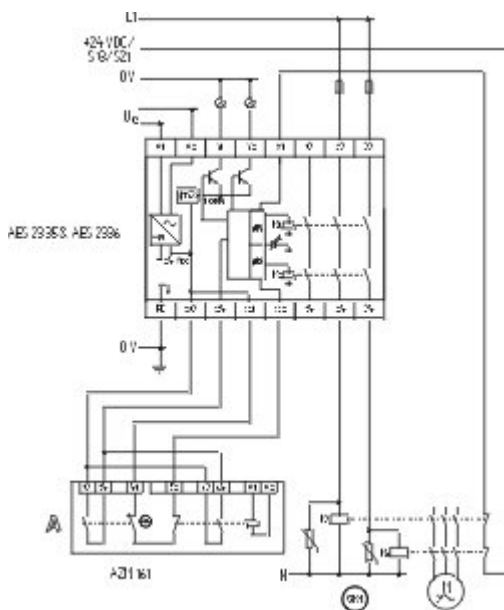

Wiring example

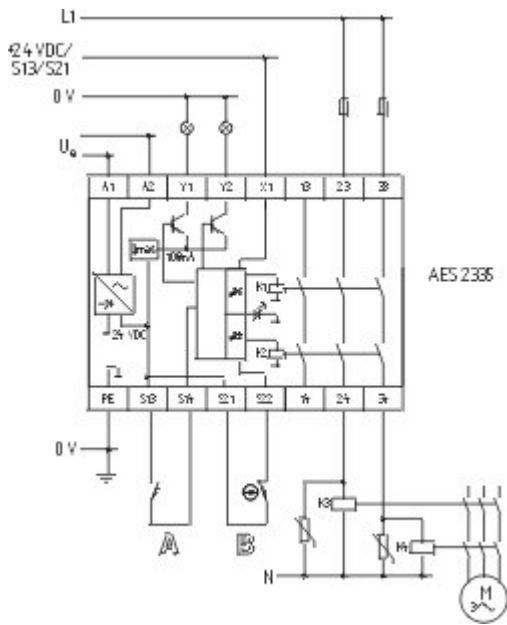

Wiring example

K.A. Schmersal GmbH & Co. KG, Möddinghofe 30, D-42279 Wuppertal

The data and values have been checked thoroughly. Technical modifications and errors excepted.

Generiert am 11.03.2014 - 11:28:18h Kasbase 2.2.18.F DBI

