

Datasheet - AZM 161 B ST1-AS RAP

AS interface safety at work / Safety switchgear / Solenoid interlock / AZM 161 AS



Preferred typ



- Solenoid interlock
- Thermoplastic enclosure
- High holding force 2000 N
- 130 mm x 90 mm x 30 mm
- Interlock with protection against incorrect locking.
- Double-insulated
- Long life
- Integrated AS-Interface
- Solenoid supply 24 VDC (Aux)
- Actuator monitored
- Manual release

(Minor differences between the printed image and the original product may exist!)

Ordering details

Product type description	AZM 161 B ST1-AS RAP
Article number	101209090
EAN code	4030661396439

Approval

Approval



Classification

Standards	EN ISO 13849-1, IEC 61508
PL	up c
Control category	1
PFH	1.14 x 10 ⁻⁶ / h
- notice	up to max. 100.000 switching cycles/year
SIL	up 1
Mission time	20 Years

If a fault exclusion for hazardous damage of the 1-channel mechanics is authorized and an adequate protection against tampering is ensured, suitable for use up to:

Standards	EN ISO 13849-1, IEC 61508
PL	up d
Control category	3
PFH value	1.01 x 10 ⁻⁷ / h

- notice	up to max. 100.000 switching cycles/year
SIL	up 2
Mission time	20 Years

Global Properties

Product name	AZM 161 AS
Standards	EN 50295, EN 60947-5-1, IEC 61508, EN ISO 13849-1
Compliance with the Directives (Y/N) 	Yes
Number of actuating directions	3 piece
Active principle	electromechanical
Duty cycle	Magnet 100 %
Materials	
- Material of the housings	Plastic, glass-fibre reinforced thermoplastic, self-extinguishing
Housing coating	None
Weight	450 g
Guard locking monitored (Y/N)	No
Actuator monitored (Y/N)	Yes
Response time	< 100 ms

Mechanical data

Actuating play in direction of actuation	5.5 mm
Design of electrical connection	connector plug M12, 4-pole
connector	bottom
Mechanical life	> 1.000.000 operations
resistance to shock	30 g / 11 ms
Resistance to vibration	10 Hz ... 150 Hz, Amplitude 0,35 mm
Emergency unlocking device (Y/N)	No
Manual release (Y/N)	Yes
Emergency release (Y/N)	No
Latching force	30 N
Clamping force F_{max}	2000 N
Max. Actuating speed	2 m/s
Actuating frequency	max. 1000 / h

Ambient conditions

Ambient temperature	
- Min. environmental temperature	-25 °C
- Max. environmental temperature	+60 °C
Storage and transport temperature	
- Min. Storage and transport temperature	-25 °C
- Max. Storage and transport temperature	+85 °C
Relative humidity	30 % ... 95 %
- non-condensing	
Protection class	IP67 to IEC/EN 60529
Protection rating	II 
Air clearances and creepage distances To IEC/EN 60664-1	
- Rated impulse withstand voltage U_{imp}	0,8 kV
- Rated insulation voltage U_i	32 VDC
- Overvoltage category	III
- Degree of pollution	3

Electrical data

Power to unlock	No
Power to lock	Yes

Electrical data - AS interface

AS-i Supply voltage	26.5 ... 31.6 VDC, Protection against polarity reversal
AS-i operating current	max. 100 mA
AS-i Device insulation	internally short-circuit proof
AS-i Specification	
- version	V 2.1
- Profile	S-7.B.F.E
- IO-Code	0x7
- ID-Code	0xB
- ID-Code1	0xF
- ID-Code2	0xE
AS-i Inputs	
- Channel 1	Data bits DI 0/DI 1= dynamic code transmission
- Channel 2	Data bits DI 2/DI 3= dynamic code transmission
AS-i Outputs	
- DO 0	Solenoid control
- DO 1	not used
- DO 2	not used
- DO 3	not used
AS-i Parameter bits	
- P0	Actuator detected
- P1	Solenoid interlock locked
- P2	magnet voltage in tolerance range
- P3	error message - locking/unlocking of the solenoid interlock blocked
AS-i input module address	0
- Default on address 0, programmable via the AS-Interface Master or Hand-held programming device	

Electrical data - Auxiliary voltage (Aux)

Supply voltage U_B	24 VDC (-15 % / +10 %) stabilised PELV
Operating current	≤ 500 mA
Device insulation	≤ 4 A (if used in accordance with UL 508)

LED switching conditions display

LED switching conditions display (Y/N)	Yes
AS-i LED switching conditions display	
(1) yellow LED	Channel 2 / AS-i SaW Bit 2,3
(2) green/red LED (AS-i duo LED)	Supply voltage / Communication error / slave address = 0 or periphery error
(3) yellow LED	Channel 1 / AS-i SaW Bit 0,1

ATEX

Explosion protection categories for gases	None
Explosion protected category for dusts	None

Miscellaneous data

Applications



sliding safety guard,



removable guard,



hinged safety guard

Dimensions

Dimensions of the sensor

- Width of sensor	130 mm
- Height of sensor	90 mm
- Length of sensor	30 mm

Pin assignment

1	AS-i +
2	Aux - (P)
3	AS-i -
4	Aux + (P)

notice

Interlocks with power to lock principle may only be used in special cases after a thorough evaluation of the accident risk, since the guarding device can immediately be opened on failure of the electrical power supply or when the main switch is opened.

Manual release

- For maintenance, installation, etc.
- For manual release using M5 triangular key, available as accessory

Included in delivery

Actuators must be ordered separately.

Ordering code

AZM 161 (1) (2)-AS (3)(4)(5)(6)

(1)	
Z	Guard locking monitored
B	Actuator monitored
BZ	
(2)	
ST1	Connector bottom
ST2	Connector right
(3)	
without	Latching force 5 N
R	Latching force 30 N
(4)	
without	Power to unlock
A	Power to lock
(5)	
without	Solenoid supply aus AS interface
P	Solenoid supply aus 24 VDC (Aux)

(6)

without

N

T

Manual release

Emergency release

Emergency exit

Documents

Operating instructions and Declaration of conformity (en) 569 kB, 12.03.2010

Code: mrl_azm161as_en

Operating instructions and Declaration of conformity (it) 493 kB, 15.03.2010

Code: mrl_azm161as_it

Operating instructions and Declaration of conformity (es) 495 kB, 16.03.2010

Code: mrl_azm161as_es

Operating instructions and Declaration of conformity (pl) 304 kB, 01.08.2013

Code: mrl_azm161as_pl

Operating instructions and Declaration of conformity (de) 572 kB, 12.03.2010

Code: mrl_azm161as_de

Operating instructions and Declaration of conformity (fr) 485 kB, 15.03.2010

Code: mrl_azm161as_fr

Operating instructions and Declaration of conformity (jp) 712 kB, 14.11.2011

Code: mrl_azm161as_jp

Operating instructions and Declaration of conformity (nl) 478 kB, 15.03.2010

Code: mrl_azm161as_nl

BG-test certificate (de, en) 286 kB, 01.06.2010

Code: z_161p01

Images

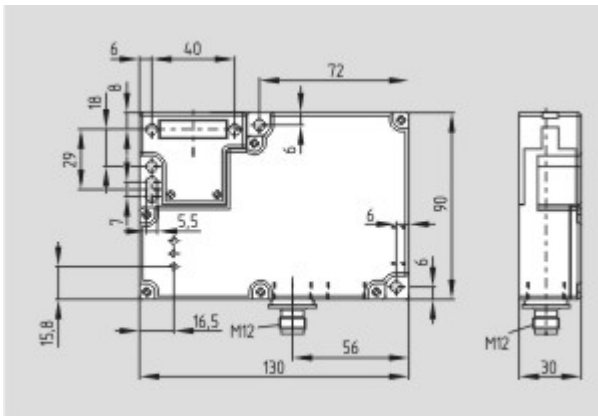

Dimensional drawing (basic component)

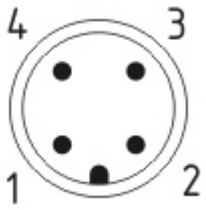

Contact arrangement

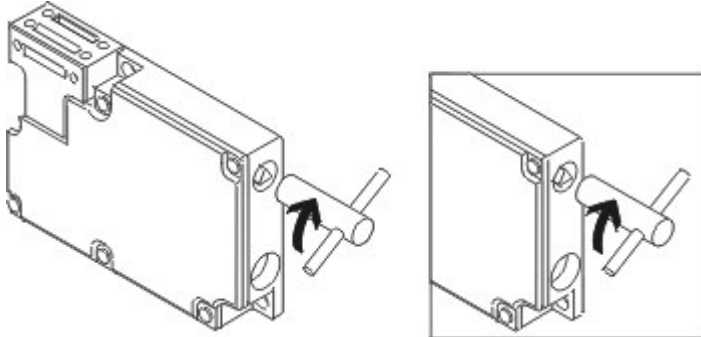

Operating principle

System components

Actuator



101145117 - AZM 161-B1



101144416 - AZM 161-B1E



101171859 - AZM 161-B1ES



101175431 - AZM 161-B1F

101171125 - AZM 161-B1S



101173089 - AZM 161-B1-2053 WITH BALL LATCH



101164100 - AZM 161-B1-1747 WITH MAGNETIC LATCH



101178199 - AZM 161-B1-2024



101176642 - AZM 161-B1-2177 WITH CENTERING GUIDE



101174113 - AZM 161-B6-2177 WITH CENTERING GUIDE

- For very small actuating radii



101170375 - AZM 161-B6S



101144420 - AZM 161-B6

- For very small actuating radii



Door-handle system



AZM 161-STS30

- Latching handle
- Suitable for all types of guard

Accessories



101100887 - TRIANGULAR KEY M5

- For manual release using M5 triangular key, available as accessory
- For maintenance, installation, etc.

K.A. Schmersal GmbH & Co. KG, Mödinghofe 30, D-42279 Wuppertal

The data and values have been checked thoroughly. Technical modifications and errors excepted.

Generiert am 13.03.2014 - 11:04:07h Kasbase 2.2.18.F DBI

Image

Image

et=sS