

## Safety relays - PSR-MC20-3NO-1DO-24DC-SP - 2700467

Please be informed that the data shown in this PDF Document is generated from our Online Catalog. Please find the complete data in the user's documentation. Our General Terms of Use for Downloads are valid (<http://phoenixcontact.com/download>)



Safety relay for emergency stop/safety doors up to SILCL 1, Cat. 1, PL c, depending on the application up to SILCL 3, Cat. 4, PL e, 1-channel operation, automatic/manual start, 3 enabling current paths,  $U_s = 24\text{ V DC}$ , plug-in spring-cage terminal block

The figure shows a version with a screw connection

### Why buy this product

- Up to Cat. 1/PL c according to ISO 13849-1, SILCL 1 according to IEC 62061
- Depending on the application, up to Cat. 4/PL e according to ISO 13849-1, SILCL 3 according to IEC 62061
- Low housing width of just 12.5 mm
- Single-channel control
- 3 enabling current paths, 1 digital signal output
- Manually monitored and automatic activation in a single device



### Key Commercial Data

Packing unit	1 pc
GTIN	 4 046356 912754
Weight per Piece (excluding packing)	173.4 g
Custom tariff number	85371099
Country of origin	Germany
Note	Made to Order (non-returnable)

### Technical data

#### Note

Utilization restriction	EMC: class A product, see manufacturer's declaration in the download area
-------------------------	---

#### Dimensions

Width	12.5 mm
Height	116.6 mm

# Safety relays - PSR-MC20-3NO-1DO-24DC-SP - 2700467

## Technical data

### Dimensions

Depth	114.5 mm
-------	----------

### Ambient conditions

Ambient temperature (operation)	-40 °C ... 55 °C (observe derating)
Ambient temperature (storage/transport)	-40 °C ... 85 °C
Max. permissible relative humidity (operation)	75 % (on average, 85% infrequently, non-condensing)
Max. permissible humidity (storage/transport)	75 % (on average, 85% infrequently, non-condensing)
Shock	15g
Vibration (operation)	10 Hz ... 150 Hz, 2g
Maximum altitude	max. 2000 m (Above sea level)

### Input data

Rated control supply voltage $U_s$	24 V DC -15 % / +10 %
Power consumption at $U_s$	typ. 1.92 W
Rated control supply current $I_s$	typ. 80 mA
Typical inrush current	5 A ( $\Delta t = 200 \mu s$ at $U_s$ )
Current consumption	< 5 mA (with $U_s/I_x$ to S12)
	< 10 mA (with $U_s/I_x$ to S34)
	> -5 mA (with $U_s/I_x$ to S34)
Voltage at input/start and feedback circuit	24 V DC -15 % / +10 %
Typical response time	< 175 ms (automatic start)
	< 175 ms (manual, monitored start)
Typical pick-up time	< 250 ms (when controlled via A1)
Typical release time	< 20 ms (when controlled via A1 or S12)
Recovery time	< 500 ms
Status display	3 x green LED
Maximum switching frequency	0.5 Hz
Max. permissible overall conductor resistance	150 $\Omega$

### Output data

Contact type	3 enabling current paths
Contact material	AgSnO <sub>2</sub>
Minimum switching voltage	20 V AC/DC
Maximum switching voltage	250 V AC/DC
Limiting continuous current	6 A (N/O contact)
Inrush current, minimum	3 mA
Maximum inrush current	6 A
Sq. Total current	48 A <sup>2</sup> (see to derating)
Switching capacity	min. 60 mW
Output fuse	6 A gL/gG (N/O contact)
	4 A gL/gG (for low-demand applications)

# Safety relays - PSR-MC20-3NO-1DO-24DC-SP - 2700467

## Technical data

### Alarm outputs

Number of outputs	1 (digital, PNP)
Voltage	22 V DC ( $U_s - 2 V$ )
Current	max. 100 mA
Maximum inrush current	500 mA ( $\Delta t = 1 \text{ ms at } U_s$ )
Short-circuit protection	no

### General

Relay type	Electromechanical relay with forcibly guided contacts in accordance with IEC/EN 61810-3 (EN 50205)
Mechanical service life	$10 \times 10^6$ cycles
Net weight	173.4 g
Mounting type	DIN rail mounting
Assembly instructions	See derating curve
Degree of protection	IP20
Min. degree of protection of inst. location	IP54
Mounting position	vertical or horizontal
Parameters as per EN ISO 13849	1 (up to Cat. 4 depending on the application)
Stop category	0
Parameters for IEC 61508	1
Designation	Air clearances and creepage distances between the power circuits
Standards/regulations	DIN EN 50178
Rated surge voltage/insulation	Safe isolation, reinforced insulation 6 kV between input circuit and enabling current path (13/14) and enabling current path (23/24) and enabling current path (33/34) Basic insulation 4 kV between all current paths and housing
Rated insulation voltage	250 V AC
Pollution degree	2
Overvoltage category	III
Housing material	PBT

### Connection data

Connection method	Spring-cage connection
pluggable	Yes
Conductor cross section solid min.	0.2 mm <sup>2</sup>
Conductor cross section solid max.	1.5 mm <sup>2</sup>
Conductor cross section flexible min.	0.2 mm <sup>2</sup>
Conductor cross section flexible max.	1.5 mm <sup>2</sup>
Conductor cross section AWG min.	24
Conductor cross section AWG max.	16
Stripping length	8 mm

# Safety relays - PSR-MC20-3NO-1DO-24DC-SP - 2700467

## Classifications

### eCl@ss

eCl@ss 5.1	27371901
eCl@ss 6.0	27371819
eCl@ss 8.0	27371819

### ETIM

ETIM 5.0	EC001449
----------	----------

## Approvals

### Approvals

---

#### Approvals

UL Listed / cUL Listed / EAC / Functional Safety / cULus Listed

---

#### Ex Approvals

---

#### Approvals submitted

---

### Approval details

UL Listed
-----------

cUL Listed
------------

EAC
-----

Functional Safety
-------------------

cULus Listed
--------------

## Drawings

# Safety relays - PSR-MC20-3NO-1DO-24DC-SP - 2700467

Block diagram

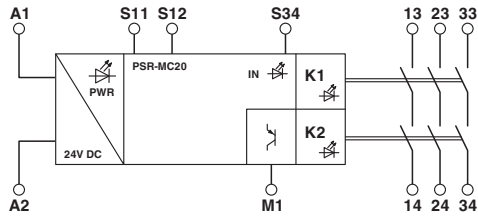

Block diagram

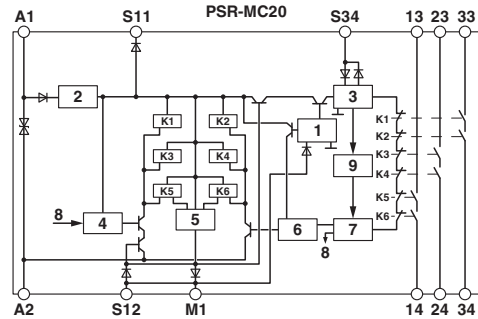

**Key:**

- 1 = Input circuit
- 2 = Voltage limitation
- 3 = Start circuit
- 4 = Control circuit channel 1
- 5 = Control circuit signal output
- 6 = Control circuit channel 2
- 7 = Start channel 1 and 2
- 8 = Channel 1
- 9 = Diagnostics
- K1, K2 ... K6 = Force-guided elementary relays

Circuit diagram

