

Safety relays - PSR-MS25-1NO-1DO-24DC-SC - 2904951

Please be informed that the data shown in this PDF Document is generated from our Online Catalog. Please find the complete data in the user's documentation. Our General Terms of Use for Downloads are valid (<http://phoenixcontact.com/download>)



Safety relay for emergency stop and safety doors up to SILCL 1, Cat. 1, PL c, depending on the application up to SILCL 3, Cat. 4, PL e, 1-channel operation, manual, monitored start, 1 enabling current path, $U_s = 24 \text{ V DC}$, fixed screw terminal block

Why buy this product

- Up to Cat. 1/PL c according to ISO 13849-1, SILCL 1 according to IEC 62061
- Depending on the application, up to Cat. 4/PL e according to ISO 13849-1, SILCL 3 according to IEC 62061
- Low housing width of just 6.8 mm
- Single-channel control
- 1 enabling current path, 1 digital signal output
- Manual and monitored activation



Key Commercial Data

Packing unit	1 pc
GTIN	 4 046356 904995
Weight per Piece (excluding packing)	69.0 g
Custom tariff number	85371099
Country of origin	Germany

Technical data

Note

Utilization restriction	EMC: class A product, see manufacturer's declaration in the download area
-------------------------	---

Dimensions

Width	6.8 mm
Height	93.1 mm
Depth	102.5 mm

Ambient conditions

Safety relays - PSR-MS25-1NO-1DO-24DC-SC - 2904951

Technical data

Ambient conditions

Ambient temperature (operation)	-40 °C ... 60 °C (observe derating)
Ambient temperature (storage/transport)	-40 °C ... 85 °C
Max. permissible relative humidity (operation)	75 % (on average, 85% infrequently, non-condensing)
Max. permissible humidity (storage/transport)	75 % (on average, 85% infrequently, non-condensing)
Shock	15g
Vibration (operation)	10 Hz ...150 Hz, 2g
Maximum altitude	max. 2000 m (Above sea level)

Input data

Rated control supply voltage U_s	24 V DC -15 % / +10 %
Power consumption at U_s	typ. 1 W
Rated control supply current I_s	typ. 42 mA
Typical inrush current	4.5 A ($\Delta t = 120 \mu s$ at U_s)
Current consumption	< 5 mA (with U_s/I_x to S12)
	< 10 mA (with U_s/I_x at the start circuit)
Voltage at input/start and feedback circuit	24 V DC -15 % / +10 %
Typical response time	< 175 ms
Typical release time	< 20 ms (when controlled via A1 or S12)
Recovery time	< 500 ms
Status display	2 x green LEDs
Maximum switching frequency	0.5 Hz
Max. permissible overall conductor resistance	150 Ω

Output data

Contact type	1 enabling current path
Contact material	AgSnO ₂
Minimum switching voltage	20 V AC/DC
Maximum switching voltage	250 V AC/DC
Limiting continuous current	6 A (N/O contact)
Inrush current, minimum	3 mA
Maximum inrush current	6 A
Sq. Total current	36 A ² (see to derating)
Switching capacity	min. 60 mW
Output fuse	6 A gL/gG (N/O contact)
	4 A gL/gG (for low-demand applications)

Alarm outputs

Number of outputs	1 (digital, PNP)
Voltage	22 V DC ($U_s - 2 V$)
Current	max. 100 mA
Maximum inrush current	500 mA ($\Delta t = 1 ms$ at U_s)
Short-circuit protection	no

Safety relays - PSR-MS25-1NO-1DO-24DC-SC - 2904951

Technical data

General

Relay type	Electromechanical relay with forcibly guided contacts in accordance with IEC/EN 61810-3 (EN 50205)
Mechanical service life	10 x 10 ⁶ cycles
Net weight	69 g
Mounting type	DIN rail mounting
Assembly instructions	See derating curve
Degree of protection	IP20
Min. degree of protection of inst. location	IP54
Mounting position	vertical or horizontal
Control	single-channel
Parameters as per EN ISO 13849	1 (up to Cat. 4 depending on the application)
Stop category	0
Parameters for IEC 61508	1
Designation	Air clearances and creepage distances between the power circuits
Standards/regulations	DIN EN 50178
Rated surge voltage/insulation	Safe isolation, reinforced insulation 6 kV between input circuit and enabling current path Basic insulation 4 kV between all current paths and housing
Rated insulation voltage	250 V AC
Pollution degree	2
Overvoltage category	III
Housing material	PBT

Connection data

Connection method	Screw connection
pluggable	no
Conductor cross section solid min.	0.2 mm ²
Conductor cross section solid max.	2.5 mm ²
Conductor cross section flexible min.	0.2 mm ²
Conductor cross section flexible max.	2.5 mm ²
Conductor cross section AWG min.	26
Conductor cross section AWG max.	12
Stripping length	12 mm
Screw thread	M3

Classifications

eCl@ss

eCl@ss 5.1	27371901
eCl@ss 6.0	27371819
eCl@ss 8.0	27371819

Safety relays - PSR-MS25-1NO-1DO-24DC-SC - 2904951

Classifications

ETIM

ETIM 5.0	EC001449
----------	----------

Approvals

Approvals

Approvals

UL Listed / cUL Listed / Functional Safety / EAC / cULus Listed

Ex Approvals

Approvals submitted

Approval details

UL Listed 

cUL Listed 

Functional Safety

EAC

cULus Listed 

Drawings

Safety relays - PSR-MS25-1NO-1DO-24DC-SC - 2904951

Block diagram

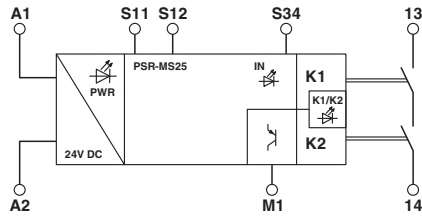

Block diagram

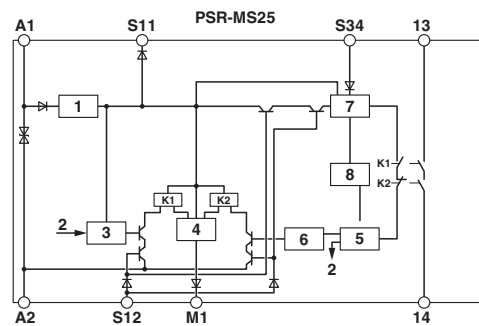

Key:

- 1 = Voltage limitation
- 2 = Channel 1
- 3 = Control circuit channel 1
- 4 = Control circuit signal output
- 5 = Start channel 1 and 2
- 6 = Control circuit channel 2
- 7 = Start circuit
- 8 = Diagnostics
- K1, K2 = Force-guided elementary relays

Application drawing

