

# End clamp - CLIPFIX 35 - 3022218

Please be informed that the data shown in this PDF Document is generated from our Online Catalog. Please find the complete data in the user's documentation. Our General Terms of Use for Downloads are valid (<http://download.phoenixcontact.com>)



Quick mounting end clamp for NS 35/7,5 DIN rail or NS 35/15 DIN rail, with marking option, width: 9.5 mm, color: gray

## Product Features

- Phoenix Contact has engineered its CLIPFIX end brackets to maintain a secure grip on the various DIN rail systems
- Design width of just 9.5 mm
- Large-surface labeling

## Key commercial data

<b>package_quantity</b>	50
<b>GTIN</b>	4017918156541

## Technical data

### Dimensions

<b>Length (b)</b>	55.6 mm
<b>Width (a)</b>	9.5 mm

### General

<b>Color</b>	gray
<b>Inflammability class according to UL 94</b>	V2
<b>Material</b>	PA

## classifications

### eCl@ss

<b>eCl@ss 4.0</b>	27141199
<b>eCl@ss 4.1</b>	27141199
<b>eCl@ss 5.0</b>	27141135
<b>eCl@ss 5.1</b>	27141135
<b>eCl@ss 6.0</b>	27141135
<b>eCl@ss 7.0</b>	27141135
<b>eCl@ss 8.0</b>	27141135

### ETIM

<b>ETIM 2.0</b>	EC000761
<b>ETIM 3.0</b>	EC001041

# End clamp - CLIPFIX 35 - 3022218

## classifications

### ETIM

ETIM 4.0	EC001041
ETIM 5.0	EC001041

### UNSPSC

UNSPSC 6.01	30212109
UNSPSC 7.0901	39121708
UNSPSC 11	39121708
UNSPSC 12.01	39121708
UNSPSC 13.2	39121708

## accessories

### Marker carriers

KLM 2 - 0807575



---

## Terminal marking

SBS 8:UNBEDRUCKT - 1007235



ZB 8:UNBEDRUCKT - 1052002



## End clamp - CLIPFIX 35 - 3022218

accessories

UC-TM 8 - 0818072



---

UCT-TM 8 - 0828740



---

### Mounting rail

NS 35/ 7,5 PERF 2000MM - 0801733



---

NS 35/ 7,5 UNPERF 2000MM - 0801681



---

NS 35/ 7,5 WH PERF 2000MM - 1204119



## End clamp - CLIPFIX 35 - 3022218

### accessories

NS 35/ 7,5 WH UNPERF 2000MM - 1204122



NS 35/ 7,5 AL UNPERF 2000MM - 0801704



NS 35/ 7,5 ZN PERF 2000MM - 1206421



NS 35/ 7,5 ZN UNPERF 2000MM - 1206434



NS 35/ 7,5 CU UNPERF 2000MM - 0801762



NS 35/ 7,5 CAP - 1206560



## End clamp - CLIPFIX 35 - 3022218

accessories

---

NS 35/15 PERF 2000MM - 1201730



NS 35/15 UNPERF 2000MM - 1201714



NS 35/15 WH PERF 2000MM - 0806602



NS 35/15 WH UNPERF 2000MM - 1204135



NS 35/15 AL UNPERF 2000MM - 1201756



## End clamp - CLIPFIX 35 - 3022218

accessories

NS 35/15 ZN PERF 2000MM - 1206599



NS 35/15 ZN UNPERF 2000MM - 1206586



NS 35/15 CU UNPERF 2000MM - 1201895



NS 35/15 CAP - 1206573



NS 35/15-2,3 UNPERF 2000MM - 1201798



**Labeled terminal marker**

## End clamp - CLIPFIX 35 - 3022218

### accessories

ZB 8 CUS - 0825011



---

UC-TM 8 CUS - 0824597



---

UCT-TM 8 CUS - 0829616



---

ZB 8,LGS:FORTL.ZAHLEN - 1052015



---

ZB 8,QR:FORTL.ZAHLEN - 1052028



---

ZB 8,LGS:L1-N,PE - 1052413



# End clamp - CLIPFIX 35 - 3022218

accessories

## Drawings

Dimensioned drawing

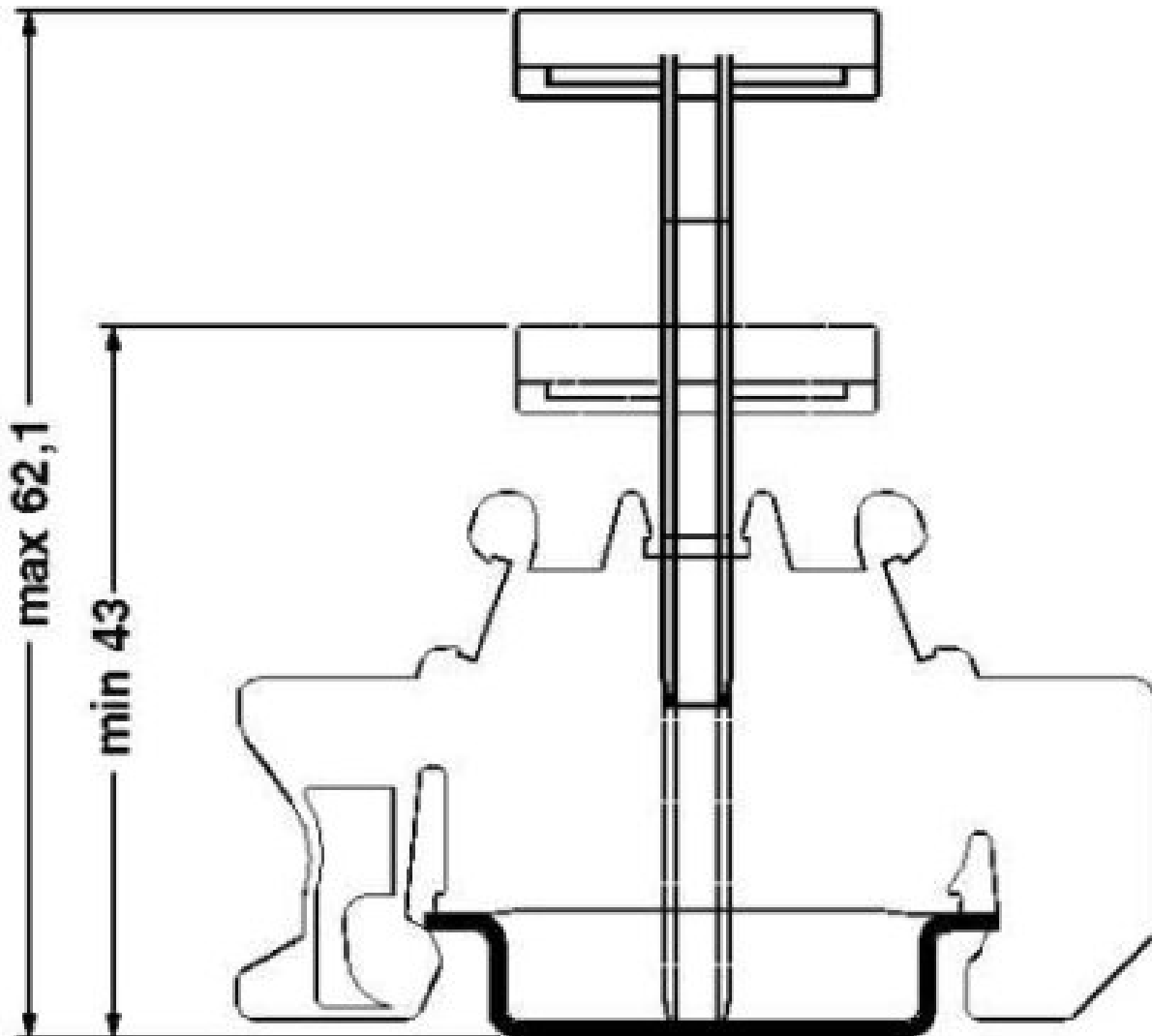



# End clamp - CLIPFIX 35 - 3022218

Dimensioned drawing

