

Diode block - EMG 45-DIO14M/LP - 2950132

Please be informed that the data shown in this PDF Document is generated from our Online Catalog. Please find the complete data in the user's documentation. Our General Terms of Use for Downloads are valid (<http://download.phoenixcontact.com>)



Lamp test module, 2 diodes with common cathode: with 7 pairs, with common triggering

The illustration shows version EMG 45-DIO 8 E/LP



Key commercial data

package_quantity	5
GTIN	4017918083984

Technical data

Dimensions

Width	45 mm
Height	75 mm
Depth	55 mm

Ambient conditions

Ambient temperature (operation)	-20 °C ... 50 °C
Ambient temperature (storage/transport)	-40 °C ... 70 °C

General

Max. operating voltage	250 V AC
Peak reverse voltage per diode	1300 V
Reverse current per diode	≤ 5 µA
Conducting state voltage per diode	approx. 0.8 V
Conducting state current per diode	0.7 A (with single load)
Conducting state current per diode	0.2 A (with simultaneous loads)
Pollution degree	2
Surge voltage category	III, basic insulation (as per EN 50178)
Mounting position	any
Assembly instructions	In rows with zero spacing

Connection data

Conductor cross section solid min.	0.2 mm ²
Conductor cross section solid max.	4 mm ²

Diode block - EMG 45-DIO14M/LP - 2950132

Technical data

Connection data

Conductor cross section stranded min.	0.2 mm ²
Conductor cross section stranded max.	2.5 mm ²
Conductor cross section AWG/kcmil min.	24
Conductor cross section AWG/kcmil max	12
Stripping length	8 mm
Screw thread	M3
Connection method	Screw connection

classifications

eCl@ss

eCl@ss 4.0	27250312
eCl@ss 4.1	27260801
eCl@ss 5.0	27260801
eCl@ss 5.1	27260801
eCl@ss 6.0	27242602
eCl@ss 7.0	27242602
eCl@ss 8.0	27242602

ETIM

ETIM 2.0	EC001432
ETIM 3.0	EC001597
ETIM 4.0	EC001597
ETIM 5.0	EC000683

UNSPSC

UNSPSC 6.01	30211506
UNSPSC 7.0901	39121008
UNSPSC 11	39121008
UNSPSC 12.01	39121008
UNSPSC 13.2	39121008

approvals

GOST /

Approval details



Diode block - EMG 45-DIO14M/LP - 2950132

accessories

EMG-GKS 12 - 2947035



Drawings

Application drawing

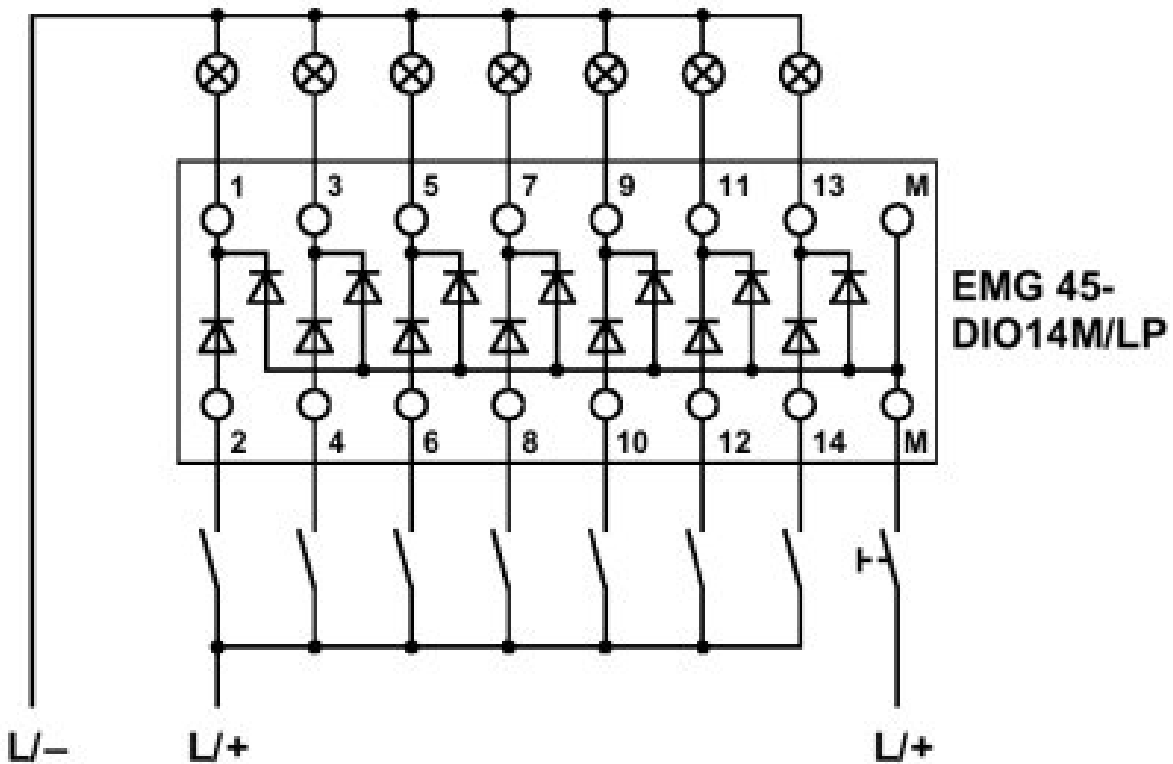

Diode block - EMG 45-DIO14M/LP - 2950132

Circuit diagram

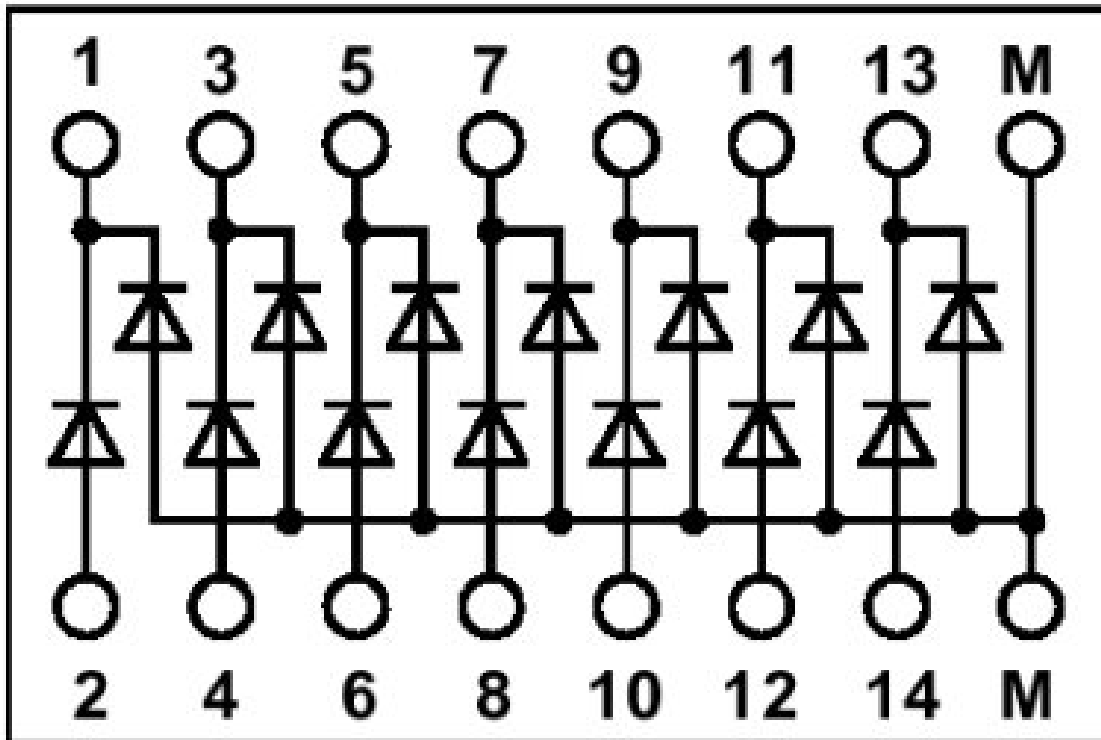

© Phoenix Contact 2014 - all rights reserved
<http://www.phoenixcontact.com>