

Contact insert - VC-TFS 8 - 1852820

Please be informed that the data shown in this PDF Document is generated from our Online Catalog. Please find the complete data in the user's documentation. Our General Terms of Use for Downloads are valid (<http://download.phoenixcontact.com>)



Contact insert module, for sleeve frames, with screw connection, 8-pos., 160 V / 10 A

Product Features

- Compact design
- Proven COMBICON technology
- Universal connection
- Can be keyed to prevent incorrect connection

Key commercial data

package_quantity	50
GTIN	4017918127152

Technical data

General

Note	Connectors may only be connected/disconnected when under no load.
Connection method	Screw connection
Connection method	Screw connection
Tightening torque	0.22 Nm ... 0.25 Nm
Pollution degree	3
Surge voltage category	III
Number of positions	8
Insertion/withdrawal cycles	≥ 100
Conductor cross section	0.14 mm ² ... 1.5 mm ²
Connection cross section AWG	28 ... 16
Stripping length of the individual wire	6 mm

Ambient conditions

Ambient temperature (operation)	-40 °C ... 100 °C
--	-------------------

Material data

Inflammability class according to UL 94	V0
Contact material	CuZn
Contact surface material	Tin-plated
Contact carrier material	PA

Contact insert - VC-TFS 8 - 1852820

Technical data

Electrical characteristics

Rated voltage (III/3)	160 V
Rated surge voltage	2.5 kV
Rated surge voltage	2.5 kV
Rated current	10 A
Rated current	10 A

classifications

eCl@ss

eCl@ss 4.0	27140816
eCl@ss 4.1	27140816
eCl@ss 5.0	27371205
eCl@ss 5.1	27371205
eCl@ss 6.0	27371205
eCl@ss 7.0	27371205
eCl@ss 8.0	27371205

ETIM

ETIM 2.0	EC000437
ETIM 3.0	EC000437
ETIM 4.0	EC000437
ETIM 5.0	EC000437

UNSPSC

UNSPSC 6.01	31261501
UNSPSC 7.0901	31261501
UNSPSC 11	31261501
UNSPSC 12.01	31261501
UNSPSC 13.2	31261501

approvals

UL Recognized / cUL Recognized / LR / GOST / cULus Recognized /

Approval details

	
Nominal voltage UN	250 V
Nominal current IN	8 A
mm ² /AWG/kcmil	30-14

Contact insert - VC-TFS 8 - 1852820

approvals

cUL Recognized	
Nominal voltage UN	250 V
Nominal current IN	8 A
mm ² /AWG/kcmil	30-14

LR

GOST

cULus Recognized

accessories

Coding element

CP-MSTB - 1734634



CP-HCC 4 - 1600027



Terminal marking

Contact insert - VC-TFS 8 - 1852820

accessories

SK U/5,0 WH:UNBEDRUCKT - 0803922



SK U/3,8 WH:UNBEDRUCKT - 0803906



Labeled terminal marker

SK 7,5/3,8:FORTL.ZAHLEN - 0804455



SK 5/3,8:FORTL.ZAHLEN - 0804183



SK 3,5/2,8:FORTL.ZAHLEN - 0804073



Drawings

Contact insert - VC-TFS 8 - 1852820

Diagram

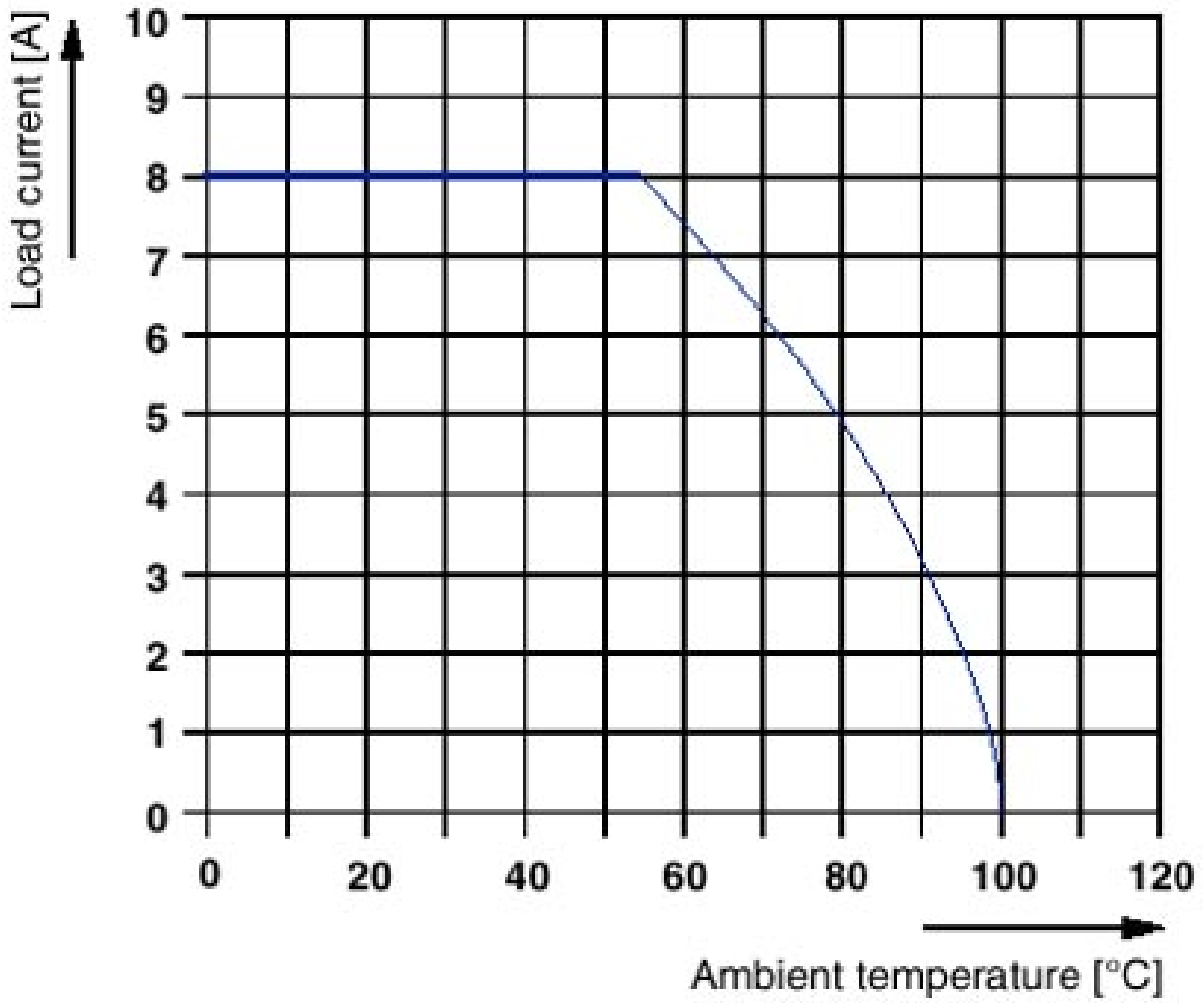

Contact insert - VC-TFS 8 - 1852820

Dimensioned drawing

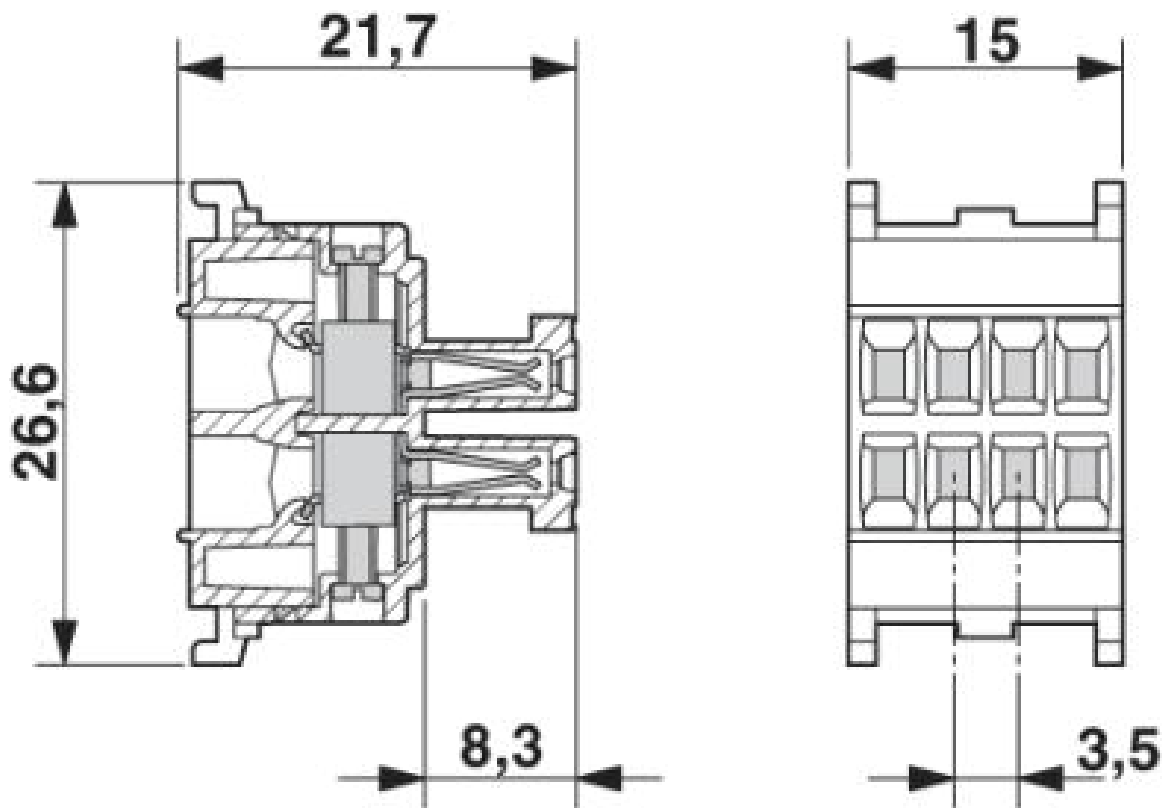

© Phoenix Contact 2014 - all rights reserved
<http://www.phoenixcontact.com>