

# Feed-through blocks with screw connection

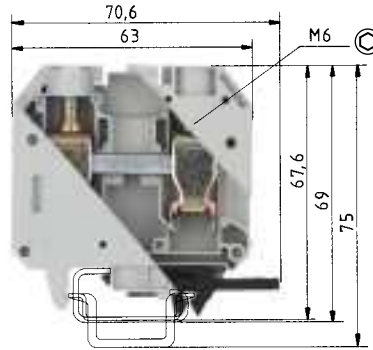

Enclosed design

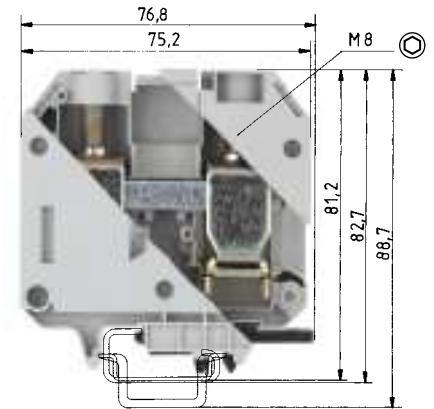

Enclosed design

0344 II 2GD IM2  
 Ex e I/II  
 EN 60947-7-1  
 UL ratings  
 CSA ratings  
 KEMA 02 ATEX 2114 U<sup>1)</sup>  
 Width  
 Approvals

Field/factory wiring  
 EN 60079-0/EN 60079-7  
 Wire strip length

### WKN 35/U

fine-stranded	stranded	V	A
10-35mm <sup>2</sup>	10-50mm <sup>2</sup>	1000V/8kV/3	125
No. 10-2 AWG		600V	150
No. 12-2 AWG		600V	150
10-35mm <sup>2</sup>	10-50mm <sup>2</sup>	690V*	86/124 <sup>3)</sup>
16mm			18mm

EPM LR AEx

### WKN 70/U

fine-stranded	stranded	V	A
10-70mm <sup>2</sup>	16-95mm <sup>2</sup>	1000V/8kV/3	192
No. 6-2/0 AWG		600V	175/175
No. 6-2/0 AWG		600V	170
10-70mm <sup>2</sup>	16-95mm <sup>2</sup>	690V	179/179 <sup>3)</sup>
24mm			24mm

LR AEx

Feed-through block	Type	Part No.	Std. Pack	Type	Part No.	Std. Pack	
Feed-through block	gray	WKN 35/U	57.535.0155.0	20	WKN 70/U	57.570.0155.0	20
Feed-through block Exi	blue	WKN 35/U BLAU	57.535.0155.6	20	WKN 70/U BLAU	57.570.0155.6	20
<b>Accessories</b>							
1. Mounting rail TS 35, DIN rail 7.5 mm high	L = 2 m	35 x 27 x 7,5 EN 60715	98.300.0000.0	1	35 x 27 x 7,5 EN 60715	98.300.0000.0	1
Mounting rail TS 35, DIN rail, 15 mm high	L = 2 m	35 x 24 x 15 EN 60715	98.360.0000.0	1	35 x 24 x 15 EN 60715	98.360.0000.0	1
Mounting rail TS 32, G rail <sup>2)</sup>	L = 2 m	9006 EN 60715 G-32	98.190.0000.0	1	9006 EN 60715 G-32	98.190.0000.0	1
2. End clamp with U-foot <sup>2)</sup>	10 mm wide	WE 1/U	Z5.523.5753.0	100	WE 1/U	Z5.523.5753.0	100
End clamp TS 35, with screw	8 mm wide	9708/2 S 35	Z5.522.8553.0	100	9708/2 S 35	Z5.522.8553.0	100
End clamp TS 35, without screw	8 mm wide	WEF 1/35	Z5.523.9353.0	100	WEF 1/35	Z5.523.9353.0	100
3. End plate	gray						
	blue						
4. Partition	gray	TWN 35	07.311.7855.0	10	TWN 70	07.311.7955.0	10
5. Cross connector with screws	2 pole	IVB WKN 35 - 2	Z7.285.2227.0	5	VB WKN 70 - 2	Z7.286.3227.0	10
	3 pole	IVB WKN 35 - 3	Z7.285.2327.0	5	VB WKN 70 - 3	Z7.286.3327.0	10
	up to 6 pole	IVB WKN 35 - 6	Z7.285.2627.0	5	VB WKN 70 - 6	Z7.286.3627.0	10
	up to 12 pole	IVB WKN 35 - 12	Z7.285.3227.0	5			
6. Partition plate with marking facility							
7. Single cover with marking facility		AD VB 35 GELB	04.326.2553.8	10	AD VB 70 GELB	04.326.2653.8	10
8. Cover with warning symbol over 4 blocks		AD VB 16/4 GELB	04.343.5256.8	10	AD VB 24/4 GELB	04.343.5356.8	10

For more accessories see pages 62-79

For marking systems see pages 72-77

<sup>\*)</sup> For maintaining the proper isolation distances, the open side of a feed-through terminal block as well as both sides of a jumper are to be enclosed by partitions.

<sup>1)</sup> Please note the mounting instructions.

<sup>2)</sup> Do not use in Ex environments.

<sup>3)</sup> With/without jumper

