

Part no. NZMN1-A50

Article no. 259082

Program

Range			Circuit-breaker
Protective function			System and cable protection Photovoltaic applications
Standard/Approval			IEC
Installation type			Fixed
Release system			Thermomagnetic release
Construction size			NZM1
Number of poles			3 pole
Standard equipment			Box terminal
Switching capacity			
400/415 V 50/60 Hz	I_{cu}	kA	50
Rated current = rated uninterrupted current			
Rated current = rated uninterrupted current	$I_n = I_u$	A	50
Setting range			
Overload trip			
	I_r	A	40 - 50
Short-circuit releases			
Non-delayed	$I_i = I_n \times$...		6 - 10

General

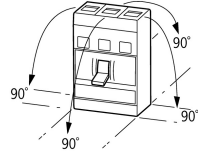
Standards			IEC/EN 60947
Protection against direct contact			Finger and back of hand proof to VDE 0106 Part 100
Climatic proofing			Damp heat, constant to IEC 60068-2-78 Damp heat, cyclic to IEC 60068-2-30
Ambient temperature		°C	
Ambient temperature, storage		°C	- 40 - + 80
Operation		°C	- 25 ... + 70
Mechanical shock resistance (10 ms half-sinusoidal shock) according to IEC 60068-2-27		g	20 (half-sinusoidal shock 20 ms)
Safe isolation to VDE 0106 Part 101 and Part 101/A1			
Between auxiliary contacts and main contacts		V AC	500
between the auxiliary contacts		V AC	300
Weight		kg	1.046
Mounting position			
Mounting position			<p>Vertical and 90° in all directions</p>  <p>With residual-current release XFI: - NZM1, N1, NZM2, N2: vertical and 90° in all directions with plug-in adapter elements - NZM1, N1, NZM2, N2: vertical, 90° right/left with withdrawable unit: - NZM3, N3: vertical, 90° left - NZM4, N4: vertical with remote operator: - NZM2, N(S)2, NZM3, N(S)3, NZM4, N(S)4: vertical and 90° in all directions</p>
Direction of incoming supply			as required
Degree of protection			
Device			In the operating controls area: IP20 (basic degree of protection)
Enclosures			With insulating surround: IP40, with door coupling rotary handle: IP66

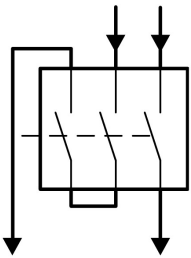
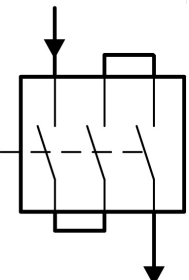
Terminations			Tunnel terminal: IP10 Phase isolator and strip terminal: IP00
Other technical data (sheet catalogue)			Weight Temperature dependency, Derating Effective power loss
Circuit-breakers			
Rated current = rated uninterrupted current	$I_n = I_u$	A	50
Rated surge voltage invariability	U_{imp}		
Main contacts		V	6000
Auxiliary contacts		V	6000
Rated operational voltage	U_e	V AC	690
Rated operational voltage	U_e	V DC	500
			<p>1) Details apply for 3 pole system protection circuit-breaker with thermomagnetic release NZMN(H)1(2)(3)-A... to 500 A.</p> <p>For rated operating voltage switching via 3 contacts:</p> <p>DC correction factor for instantaneous release response value: NZM1: 1.25, NZM2: 1.35, NZM3: 1.45</p> <p>Set value for I_i at DC = set value I_i AC/correction factor DC</p> <div style="display: flex; justify-content: space-around;"> <div style="text-align: center;"> <p>Switching of one pole via two series contacts</p>  </div> <div style="text-align: center;"> <p>Switching of one pole via three series contacts</p>  </div> </div>
Overvoltage category/pollution degree			III/3
Rated insulation voltage	U_i	V	690
For use in IT electrical power networks		V	690
Switching capacity			
Rated short-circuit making capacity	I_{cm}		
240 V	I_{cm}	kA	187
400/415 V	I_{cm}	kA	105
440 V 50/60 Hz	I_{cm}	kA	74
525 V 50/60 Hz	I_{cm}	kA	40
690 V 50/60 H	I_c	kA	17
Rated short-circuit breaking capacity I_{cn}	I_{cn}		
I_{cu} to IEC/EN 60947 test cycle O-t-CO	I_{cu}	kA	
240 V 50/60 Hz	I_{cu}	kA	85
400/415 V 50/60 Hz	I_{cu}	kA	50
440 V 50/60 Hz	I_{cu}	kA	35
525 V 50/60 Hz	I_{cu}	kA	20
690 V 50/60 Hz	I_{cu}	kA	10
500 V DC	I_{cu}	kA	15
I_{cs} to IEC/EN 60947 test cycle O-t-CO-t-CO	I_{cs}	kA	
240 V 50/60 Hz	I_{cs}	kA	85
400/415 V 50/60 Hz	I_{cs}	kA	50
440 V 50/60 Hz	I_{cs}	kA	35
525 V 50/60 Hz	I_{cs}	kA	10
690 V 50/60 Hz	I_{cs}	kA	7.5
			Maximum back-up fuse, if the expected short-circuit currents at the installation location exceed the switching capacity of the circuit-breaker.

Utilization category to IEC/EN 60947-2			A
Rated making and breaking capacity			
Rated operational current	I_e	A	
AC-1			
400 V	I_e	A	160
415 V	I_e	A	125
690 V	I_e	A	160
AC--3			
400 V	I_e	A	50
415 V	I_e	A	50
690 V	I_e	A	50
DC - -1			
500 V DC	I_e	CSA	125
DC - 3			
500 V DC	I_e	CSA	125
Lifespan, mechanical(of which max. 50 % trip by shunt/undervoltage release)	Operations		20000
Lifespan, electrical			
AC-1			
400 V V 50/60 Hz	Operations		10000
415 V V 50/60 Hz	Operations		10000
690 V 50/60 Hz	Operations		7500
AC--3			
400 V 50/60 Hz	Operations		7500
415 V 50/60 Hz	Operations		7500
690 V 50/60 Hz	Operations		5000
DC - -1			
500 V DC		Operations	10000
DC - 3			
500 V DC	Operations		5000
Max. operating frequency		Ops/h	120
Current heat losses per pole at I_{tr} are based on the maximum rated operational current of the frame size.		W	16.7
			For current heat loss per pole the specification refers to the maximum rated operational current of the frame size.
Total downtime in a short-circuit		ms	< 10

Terminal capacity

Standard equipment			Box terminal
Overview			<p>Basic equipment</p> <p>Box terminal ● - - -</p> <p>Screw connection - ● ● ●</p> <p>Accessories</p> <p>Box terminal - ● ● -</p> <p>Screw connection ● - - ●</p> <p>Tunnel terminal ● ● ● ●</p> <p>Connection on rear ● ● ● ●</p> <p>Flat conductor terminal - - - ●</p>
Round copper conductor			
Box terminal			
Solid		mm ²	1 x (10 - 16) 2 x (6 - 16)
Stranded		mm ²	1 x (25 - 70) 2 x 25
Tunnel terminal			

Solid		mm ²	1 x (16 - 95)
Stranded		mm ²	
Stranded		mm ²	1 x (25 - 95)
Bolt terminal and rear-side connection			
Direct on the switch			
Solid		mm ²	1 x (10 - 16) 2 x (6 - 16)
Stranded		mm ²	1 x (25 - 70) 2 x 25
Al conductors, Cu cable			
Solid		mm ²	1 x 16
Stranded		mm ²	
Stranded		mm ²	1 x (25 - 95)
Cu strip (number of segments x width x segment thickness)			
Box terminal			
	min.	mm ²	2 x 9 x 0.8
	max.	mm ²	9 x 9 x 0.8
Copper busbar (width x thickness)	mm		
Bolt terminal and rear-side connection			
Screw connection			M8
Direct on the switch			
	min.	mm ²	12 x 5
	max.	mm ²	16 x 5
Control cables			
		mm ²	1 x (0.75 - 2.5) 2 x (0.75 - 1.5)

Technical data according to ETIM 4.0

Number of poles			3
Rated uninterrupted current I _u		A	50
Number of auxiliary contacts as N/Cs			0
Number of auxiliary contacts as N/Os			0
Device construction			Built-in device fixed built-in technique
With under voltage release			No
Motor operator optional			YES
Integrated earth fault protection			No
Suitable for DIN rail (top hat rail) mounting			No
Setting range non-delayed short-circuit release		A	500
Setting range short-term delayed short-circuit release		A	0
Rated short-circuit breaking capacity I _{cu} at 400 V, 50 Hz		kA	50
Switched-off indicator available			No
Type of control element			Toggle lever
Connection type main current circuit			Box terminal
Motor operator integrated			No
Position of connection for main circuit			Front connection
Protection type (IP)			IP20
Number of auxiliary contacts as changeover contact			0
Setting range of overload releases		A	50

Characteristics

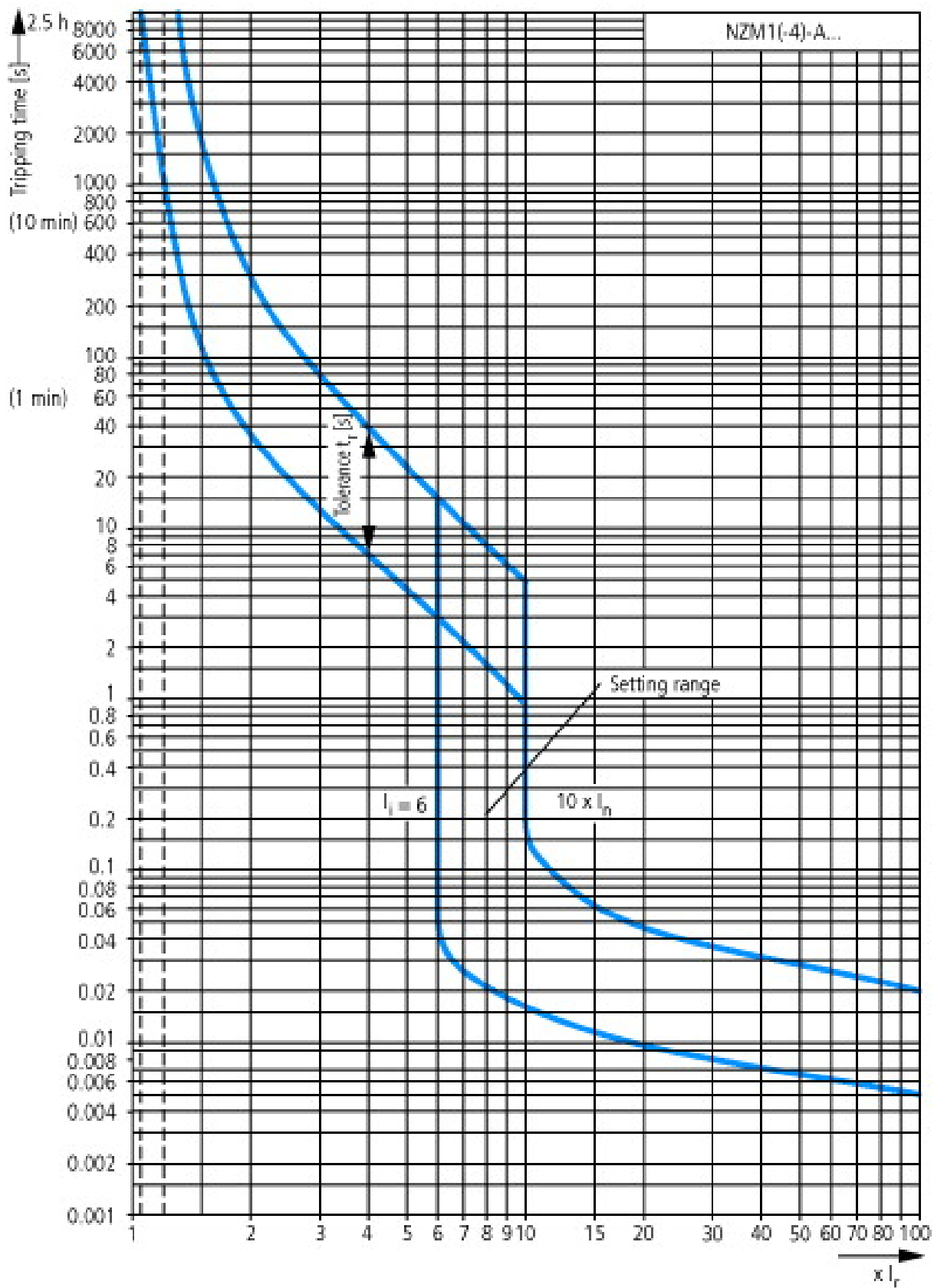

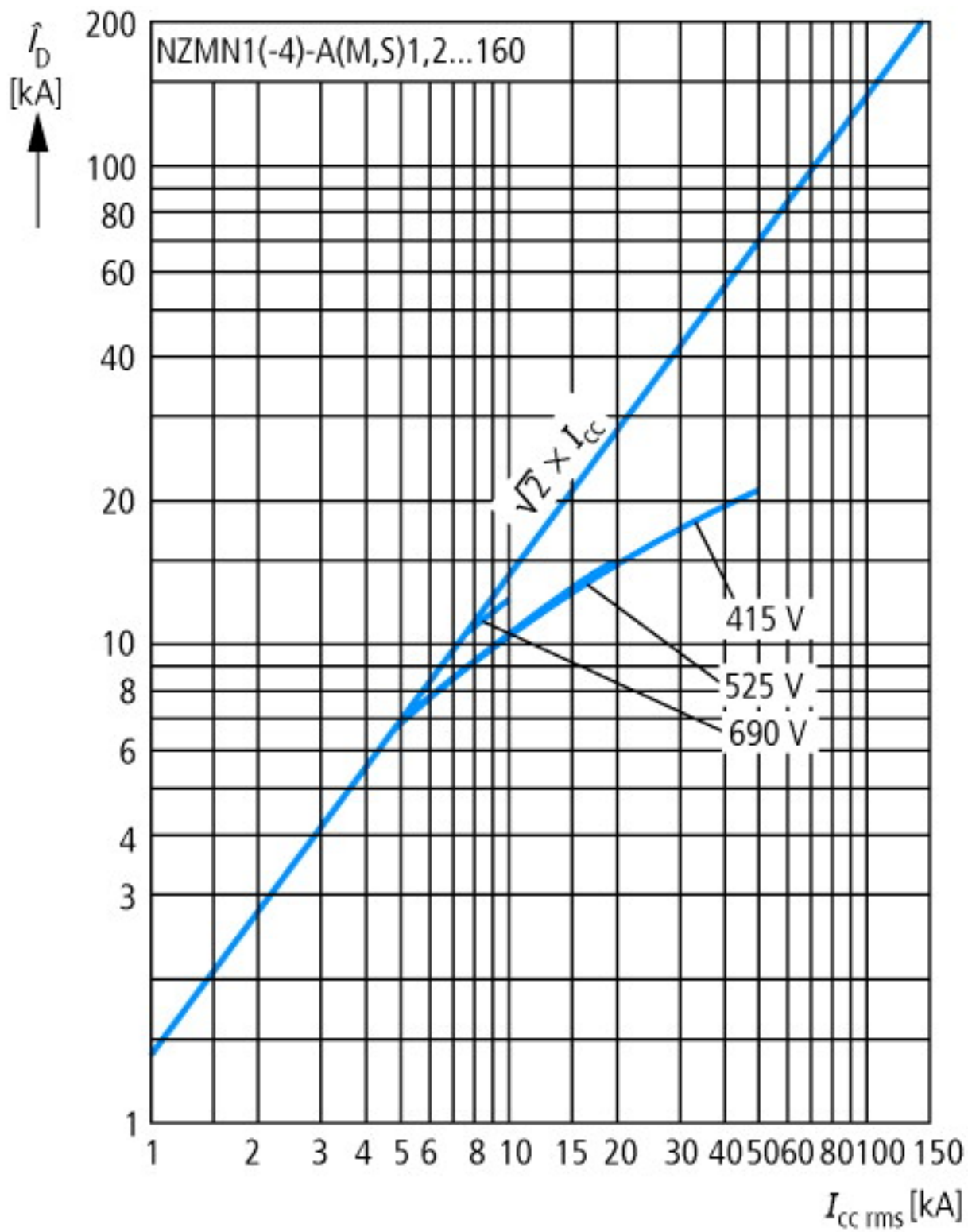

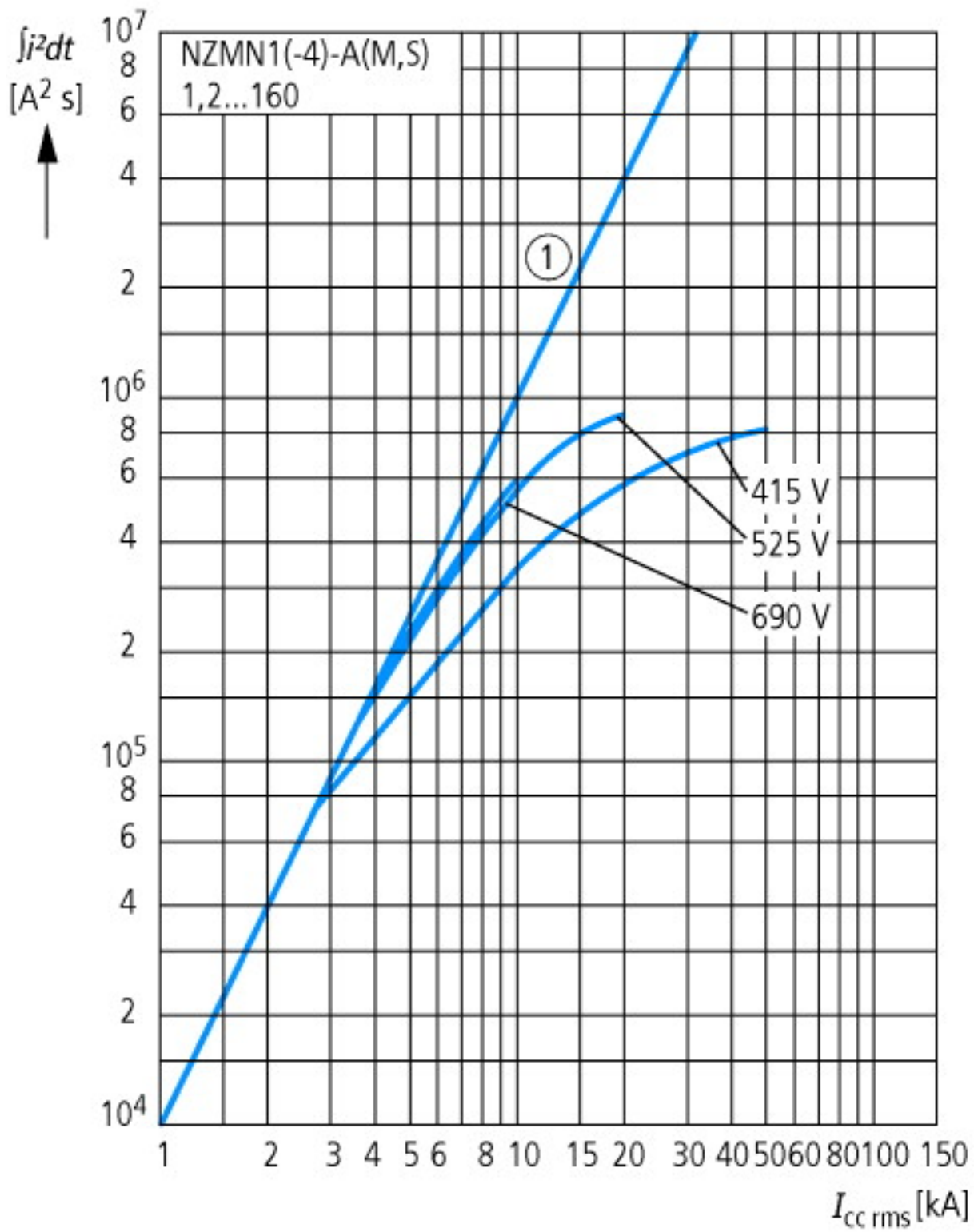

Dimensions

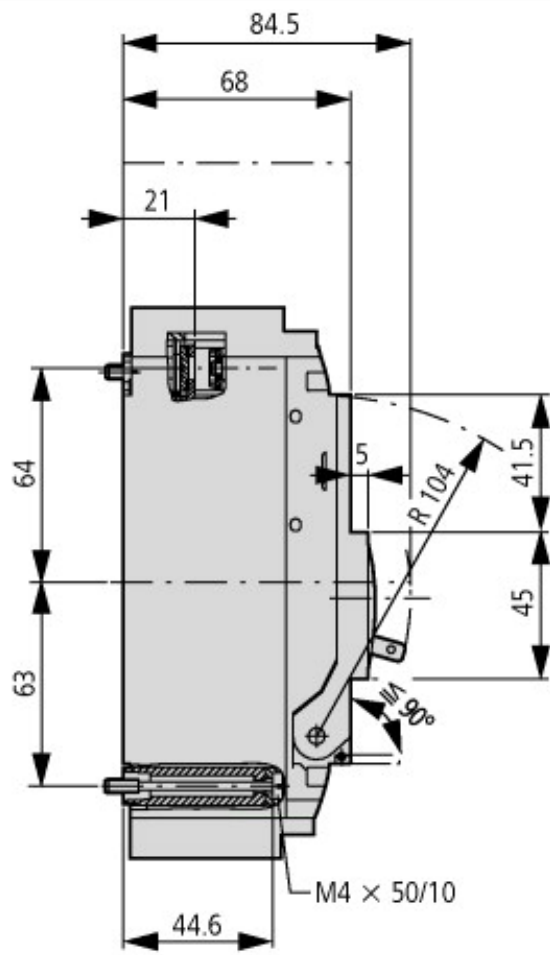
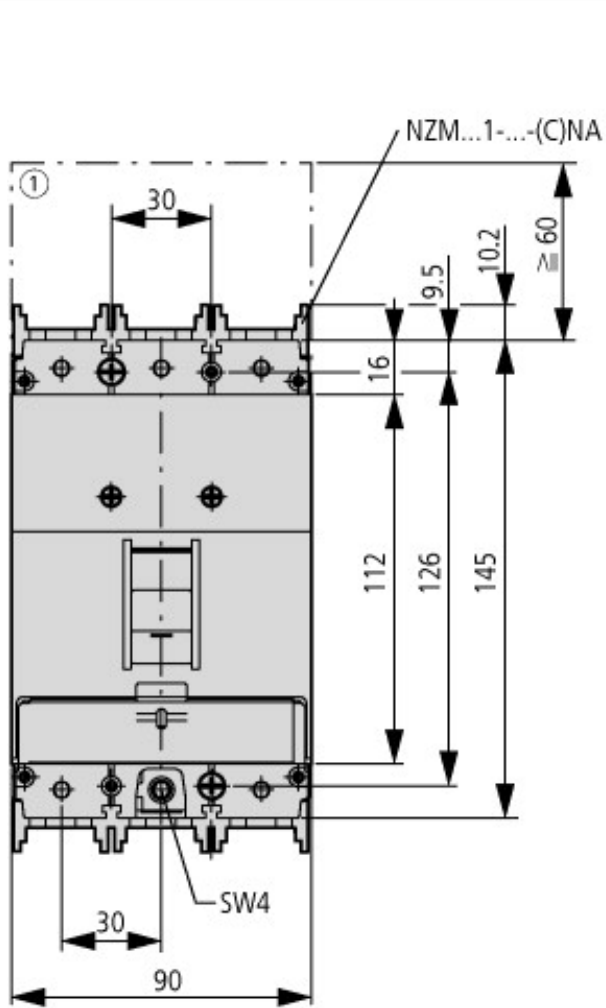

① Blow out area, minimum clearance to adjacent parts

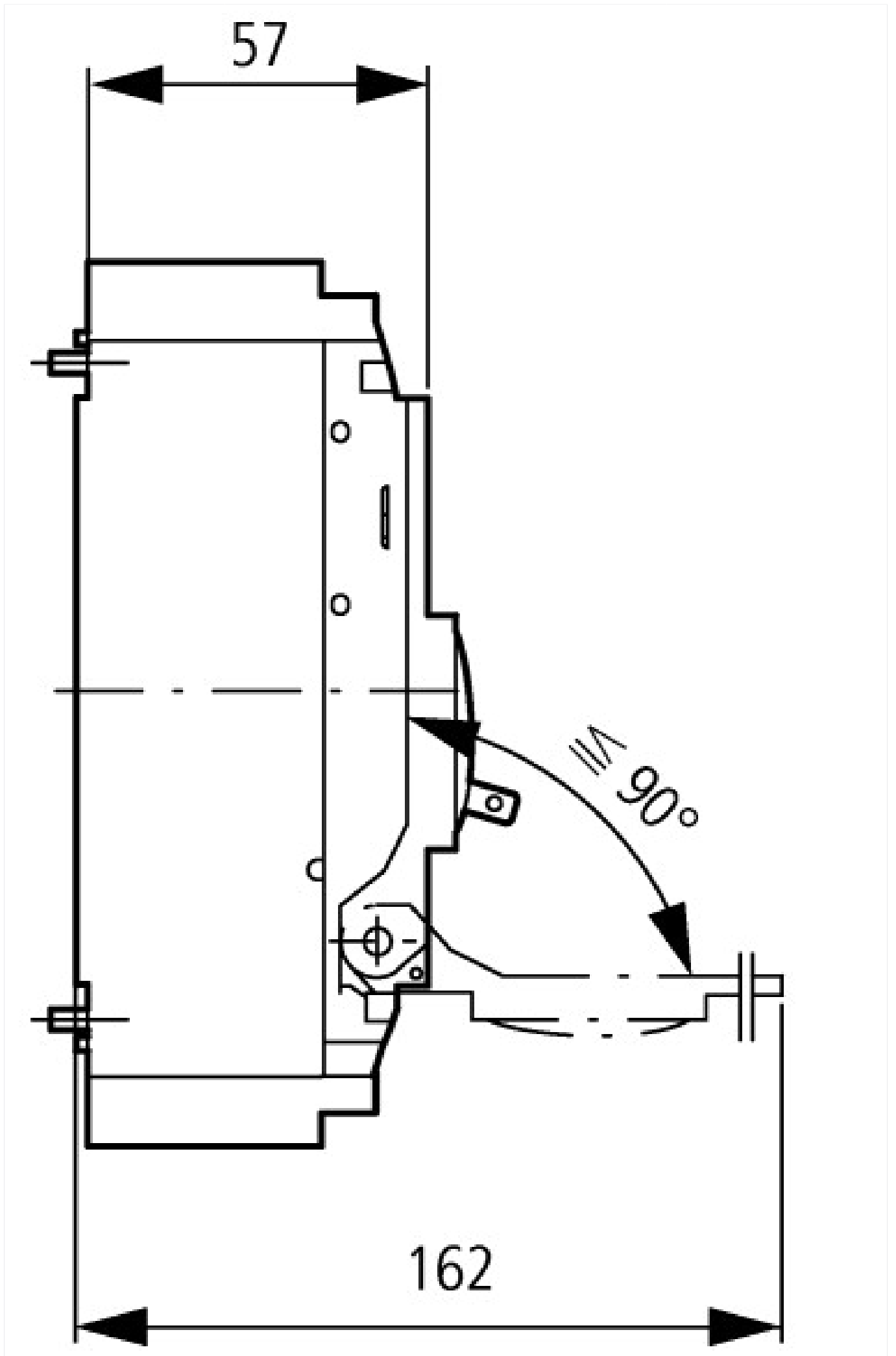

Additional product information (links)

IL01203004Z (IL01203004Z) Circuit-breaker, Switch-Disconnecter	ftp://ftp.moeller.net/DOCUMENTATION/AWA_INSTRUCTIONS/IL01203004Z2010_11.pdf
Engineering	
System and line protection	ftp://ftp.moeller.net/DOCUMENTATION/PDF/GB/CHA_NZM_123_g.pdf
Busbar Component Adapters for modern Industrial control panels	http://www.moeller.net/binary/ver_techpapers/ver960en.pdf
Setting-Specific Representation of Tripping Characteristics and Competent Assessment of their Interaction	http://www.moeller.net/binary/ver_techpapers/ver943en.pdf