



**Main switch** Surface mounting



Powering Business Worldwide™

**Part no.** P1-25/12H/SVB

**Article no.** 226900

IP65

**Program**

Range			Load current switches
Basic function			Main switches Maintenance switches Manual override switches
Part group reference (e.g. DIL)			P1
Design			Surface mounting
Protection type			IP65
			<b>totally insulated</b>
Emergency stop			As an emergency switching off/emergency stop device With red rotary handle and yellow locking ring
Standards			According to IEC/EN 60204-1, VDE 0113 Part 1
Locking facility			Lockable in the 0 (Off) position
Contact sequence			without auxiliary contacts 
Front plate no.			 <b>FS 908</b>
Main conducting paths			
No. of poles		M	3
Auxiliary contacts		N/O	0
		B	0
Max. motor rating			
AC-23A			
400/415 V 50-60 Hz	P	kW	13
Rated uninterrupted current	I <sub>u</sub>	A	25

**Approbationen**

UL approval	No
CSA approval	No

## General

Standards			IEC/EN 60947, VDE 0660, IEC/EN 60204, CSA, UL switch disconnecter according to IEC/EN 60947-3
Lifespan, mechanical	Operations	x 10 <sup>6</sup>	0.3
Maximum operating frequency		Operations h	50
Climatic proofing			Damp heat, constant, to IEC 60068-2-78; Damp heat, cyclical, to IEC 60068-2-30
Ambient temperature		°C	
Open		°C	- 25 - 50
Enclosed		°C	- 25 - 40
Mounting position			As required
Mechanical shock resistance to IEC 60068-2-27	Half-sinusoidal shock 20 ms	g	> 15

## Contacts

Rated operational voltage	U <sub>e</sub>	V AC	690
Rated impulse withstand voltage	U <sub>imp</sub>	V AC	6000
Overvoltage category/pollution degree			III/3
Rated uninterrupted current	I <sub>u</sub>	A	
open	I <sub>u</sub>	A	25
Enclosed	I <sub>u</sub>	A	25
Load rating with intermittent operation, class 12			
AB 25 % DF		x I <sub>e</sub>	2
AB 40 % DF		x I <sub>e</sub>	1.6
AB 60 % DF		x I <sub>e</sub>	1.3
Short-circuit rating			
Fuse		A gG/ gL	25
Rated short-time withstand current (1 s current)	I <sub>cw</sub>	A <sub>rms</sub>	640
Switching angles		°	90
Current heat loss per contact at I <sub>e</sub>		W	1.1

## Terminal capacities

Solid or stranded		mm <sup>2</sup>	1 x (1.5 - 6) 2 x (1.5 - 6)
Flexible with ferrule to DIN 46228		mm <sup>2</sup>	1 x (1 - 4) 2 x (1 - 4)
Terminal screw			M4
Tightening torque		Nm	1.6

## Switching capacity

AC		x U <sub>s</sub>	
Rated making capacity cos φ = 0.35		A	240
Rated breaking capacity, motor load switch cos φ = 0.35		A	
230 V		A	190
400 V		A	150
500 V		A	170
690 V		A	150
Rated operational current 440 V load-break switch AC-21A	I <sub>e</sub>	A	25
Rating, AC-3 motor load switch	P	kW	
220/230 V	P	kW	5.5
400 V	P	kW	7.5
500 V	P	kW	7.5
690 V	P	kW	7.5
AC-23A Motor load switches (main switches maintenance switches)	P	kW	
230 V	P	kW	7

400 V	P	kW	13
500 V	P	kW	11
690 V	P	kW	11
DC		$x U_s$	
DC-1, Load-break switches L/R = 1 ms			
Rated operational current	$I_e$	A	25
Voltage per contact pair in series		V	60
DC-23A, motor load switch L/R = 15 ms			
24 V			
Rated operational current	$I_e$	A	25
Contacts		Quantity	1
48 V			
Rated operational current	$I_e$	A	25
Contacts		Quantity	2
60 V			
Rated operational current	$I_e$	A	25
Contacts		Quantity	3
120 V			
Rated operational current	$I_e$	A	12
Contacts		Quantity	3

### Auxiliary contacts

Standards According to IEC/EN 60204-1, VDE 0113 Part 1

### Notes

**Notes** Main switch characteristics to IEC/EN 60204; positive opening of contacts, operator element positively located on shaft  
The rated uninterrupted current  $I_u$  is stated at max. connected cross-section.  
For terminal capacity solid, stranded and flexible:  
Max. 2 cross-section sizes difference admissible when using 2 conductors.

### Technical data according to ETIM 4.0

Number of auxiliary contacts as normally open contact			0
Number of auxiliary contacts as normally closed contact			0
Rated permanent current $I_u$		A	25
Number of poles			3
Conditioned rated short-circuit current $I_q$		kA	0
Degree of protection (IP), front side			IP65
Number of auxiliary contacts as change-over contact			0
Interlockable			YES
Motor drive integrated			No
Connection type main current circuit			Screw connection
Version as emergency stop installation			YES
Type of control element			-
Version as main switch			YES
Version as switch disconnecter compact			YES
Version as safety switch			No
Version as maintenance-/service switch			YES
Rated operation power at AC-23, 400V		kWh	13
Rated operation power AC-3, 400 V		kWh	7.5
Suitable for ground mounting			YES
Suitable for front mounting			No
Suitable for front mounting center			No
Suitable for distribution board installation			No
Suitable for intermediate mounting			No
Max. rated operation voltage $U_e$ AC		V	690
Motor drive optional			No
Voltage release optional			No
Device construction			Complete device in housing

## Characteristics

Form for ordering non-standard front plates

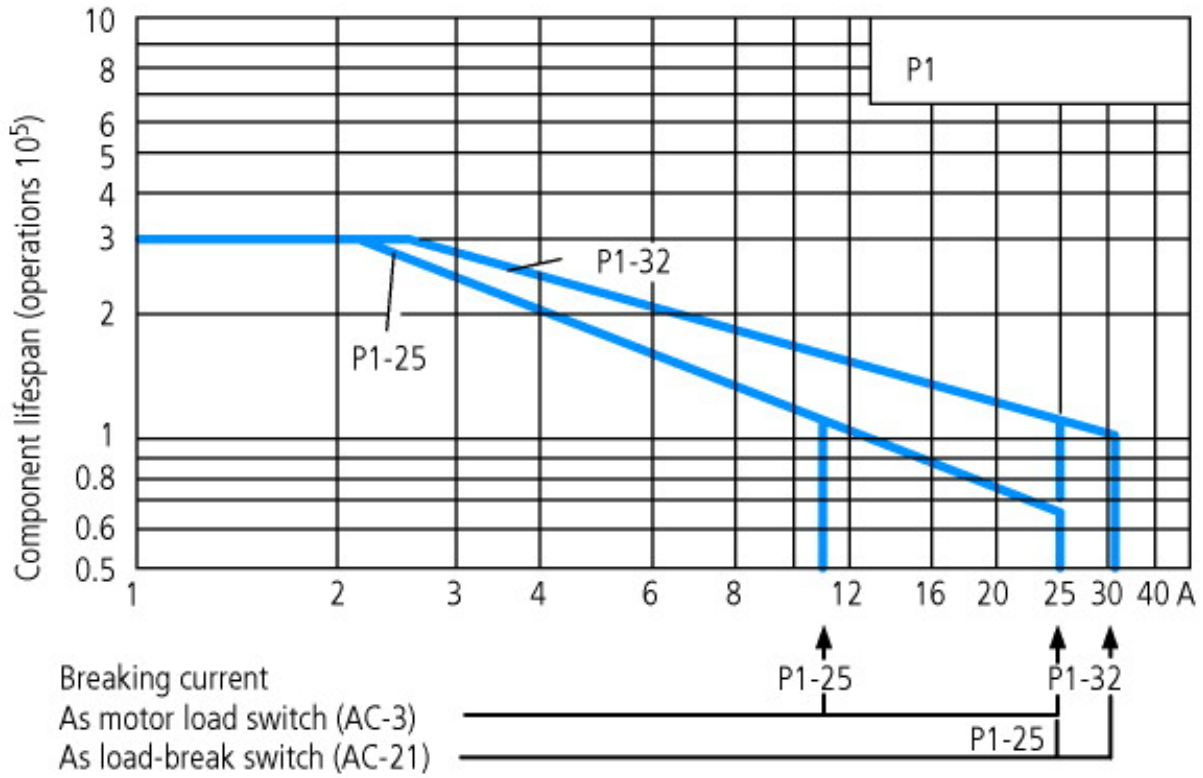

For utilisation category AC-4 (extreme load: 100 % inching, reversing or plugging)

The blocked rotor current of the motor should not exceed the rated current of the switch for AC-21A to ensure a reasonable device lifespan.

## Dimensions

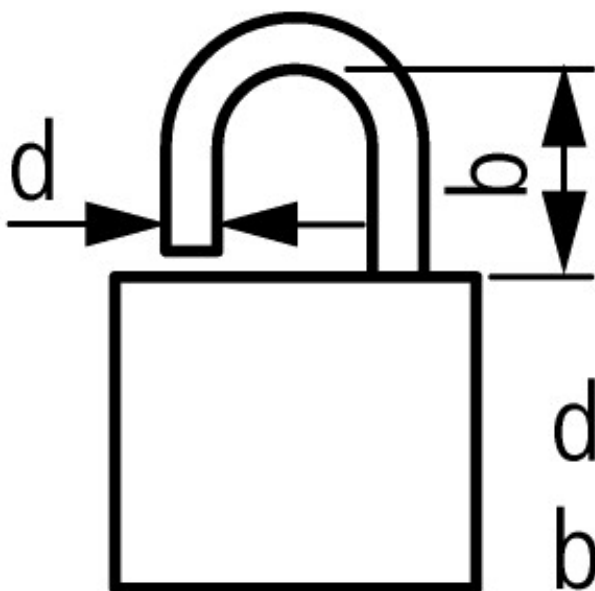
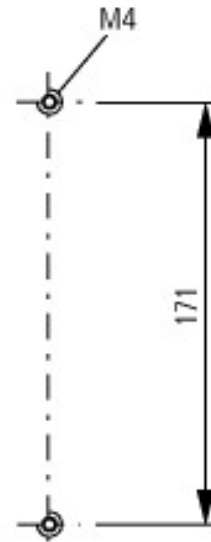
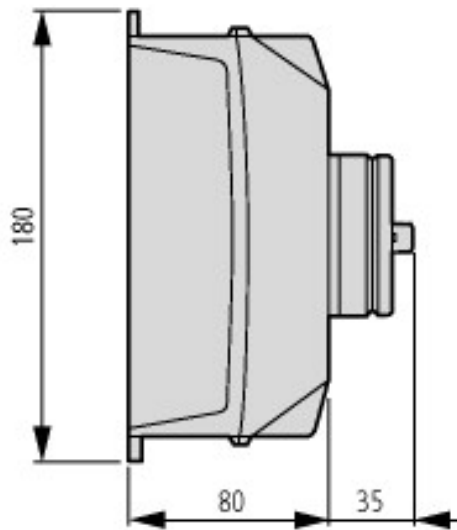

$$d = 4 - 8 \text{ mm}$$

$$b + d \leq 47 \text{ mm}$$



### Additional product information (links)

AWA1150-1689 (IL03802001Z) Switch-Disconnectors in insulated enclosures	<a href="ftp://ftp.moeller.net/DOCUMENTATION/AWA_INSTRUCTIONS/16890304.pdf">ftp://ftp.moeller.net/DOCUMENTATION/AWA_INSTRUCTIONS/16890304.pdf</a>
<b>Engineering</b>	
Technical overview	<a href="ftp://ftp.moeller.net/DOCUMENTATION/PDF/GB/Ovt_t_p_Leistung_G.pdf">ftp://ftp.moeller.net/DOCUMENTATION/PDF/GB/Ovt_t_p_Leistung_G.pdf</a>
Key to part numbers, modular system	<a href="ftp://ftp.moeller.net/DOCUMENTATION/PDF/GB/Ovt_t_p_Typenschluesel_G.pdf">ftp://ftp.moeller.net/DOCUMENTATION/PDF/GB/Ovt_t_p_Typenschluesel_G.pdf</a>
Ordering of non-standard switches	<a href="ftp://ftp.moeller.net/DOCUMENTATION/PDF/GB/Bestellformulare_de.pdf">ftp://ftp.moeller.net/DOCUMENTATION/PDF/GB/Bestellformulare_de.pdf</a>