



Comp.dev.Emer.stop/em.swit.off but.encl.





Powering Business Worldwide™

Part no. **M22-PV/KC11/IV**

Article no. **216525**

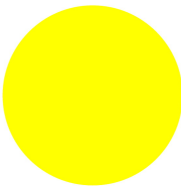

### Program

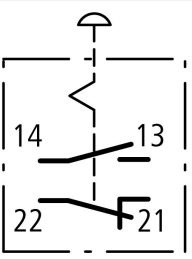
Range			RMQ-Titan (drilling dimensions 22.5 mm)
Basic function			Emergency stop buttons
Single unit/Complete unit			Complete unit
Description			Tamper-proof according to ISO 13850/EN 418 Pull to release
Colour of enclosure top			Yellow
Colour of enclosure top			
Auxiliary contacts:  = safety function, by positive opening to IEC/EN 60947-5-1			
N/O = Normally open			1 N/O
N/C = Normally closed			1 N/C 
Contact sequence			
RAL Value			RAL 1004
Front ring			Bezel: Silver
Connection to SmartWire-DT			no

### Approbationen

UL approval	Yes
CSA approval	Yes
Product Standards	IEC/EN 60947-5; UL 508; CSA-C22.2 No. 14-05; CSA-C22.2 No. 94-91; CE marking
UL File No.	E29184
UL CCN	NKCR
CSA File No.	012528
CSA Class No.	3211-03
NA Certification	UL listed, CSA certified
Degree of Protection	UL/CSA Type 3R, 4X, 12, 13

### General

Standards			IEC/EN 60947 VDE 0660
-----------	--	--	--------------------------

Lifespan, mechanical	Operations	x 10 <sup>6</sup>	> 0.1
Operating frequency	Operations/ h		≦ 600
Actuating force		n	50
Protection type			IP66, IP69K
Climatic proofing			Damp heat, constant to IEC 60068-2-78 Damp heat, cyclic to IEC 60068-2-30
Ambient temperature		°C	
Open		°C	- 25 - + 70
Mounting position			As required
Mechanical shock resistance		g	50 Shock duration 11 ms Sinusoidal according to IEC 60068-2-27

### Technical data according to ETIM 4.0

With lighting			No
Protection type (IP)			IP66
Unlocking method			Pull release
Mounting type			Flush mounting
Hole diameter		mm	22

### CAD-Data

Product standards CAD data:

<http://eaton-moeller.partcommunity.com>

### Dimensions

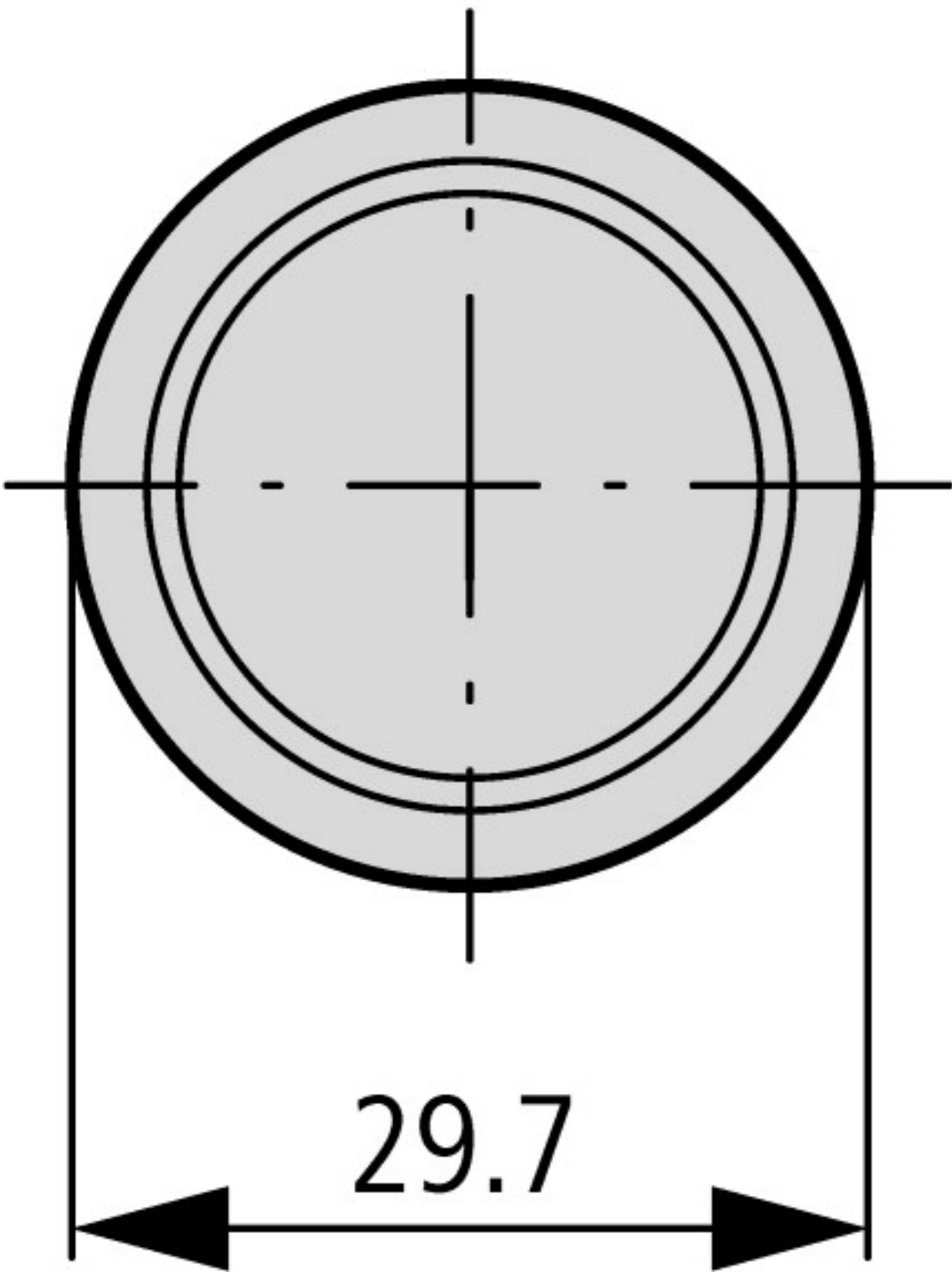

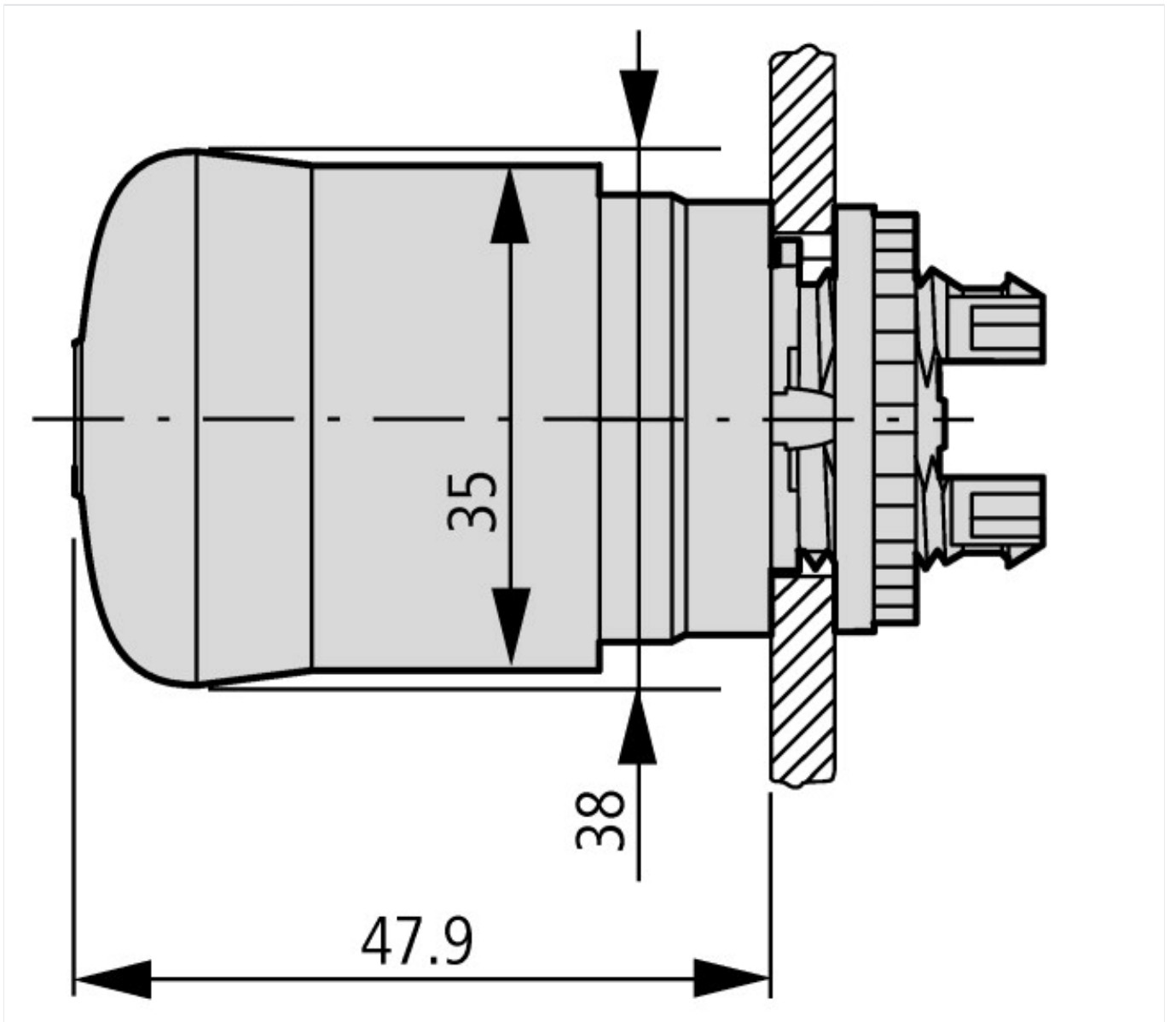

### Additional product information (links)

IL04716002Z (AWA1160-1745) RMQ-Titan System	<a href="ftp://ftp.moeller.net/DOCUMENTATION/AWA_INSTRUCTIONS/IL04716002Z2011_03.pdf">ftp://ftp.moeller.net/DOCUMENTATION/AWA_INSTRUCTIONS/IL04716002Z2011_03.pdf</a>
<b>Engineering</b>	
Key to part numbers	<a href="ftp://ftp.moeller.net/DOCUMENTATION/PDF/GB/TYPENSCHLUESSEL_RM-Q-TITAN_de.pdf">ftp://ftp.moeller.net/DOCUMENTATION/PDF/GB/TYPENSCHLUESSEL_RM-Q-TITAN_de.pdf</a>
Engineering	<a href="ftp://ftp.moeller.net/DOCUMENTATION/PDF/GB/PRO_RMQTitan_D_de.pdf">ftp://ftp.moeller.net/DOCUMENTATION/PDF/GB/PRO_RMQTitan_D_de.pdf</a>
Ordering example for custom complete units	<a href="ftp://ftp.moeller.net/DOCUMENTATION/PDF/GB/Bestellbeispiel_F0315_COMBINATION_de.pdf">ftp://ftp.moeller.net/DOCUMENTATION/PDF/GB/Bestellbeispiel_F0315_COMBINATION_de.pdf</a>
Order form for custom complete units	<a href="ftp://ftp.moeller.net/DOCUMENTATION/PDF/GB/FORM_F0315_Combination_de.pdf">ftp://ftp.moeller.net/DOCUMENTATION/PDF/GB/FORM_F0315_Combination_de.pdf</a>