



Contactor,4kW/400V,DC operated



Powering Business Worldwide™

Part no. DILEM-10-G(24VDC)

Article no. 010213

Program

Product range			Contactors
Subrange			DILEM contactors
Application			Mini Contactors for Motors and Resistive Loads
Description			With auxiliary contact
Pole			3 pole
Connection technique			Screw terminals
Rated operational current			
AC-3			
400 V	I_e	A	9
AC-1			
Conventional free air thermal current, 3 pole, 50 - 60 Hz			
Open			
at 50 °C	$I_{th}=I_e$	A	20
enclosed	I_{th}	A	16
Max. rating for three-phase motors, 50 - 60 Hz			
AC-3			
220 V 230 V	P	kW	2.2
380 V 400 V	P	kW	4
660 V 690 V	P	kW	4
AC-4			
220 V 230 V	P	kW	1.5
380 V 400 V	P	kW	3
660 V 690 V	P	kW	3
Contacts			
N/O = Normally open			1 N/O
Contact sequence			
For use with			...DILEM ...DILE
Actuating voltage			24 V DC
Voltage AC/DC			DC operation

Approbationen

UL approval	Yes
CSA approval	Yes
Product Standards	IEC/EN 60947-4-1; UL 508; CSA-C22.2 No. 14-05; CE marking
UL File No.	E29096
UL CCN	NLDX
CSA File No.	012528
CSA Class No.	3211-04
NA Certification	UL listed, CSA certified
Specially designed for NA	No

General

Standards			IEC/EN 60947, VDE 0660, CSA, UL
Maximum operating frequency		Ops./h	
Mechanical		Ops./h	9000
Climatic proofing			Damp heat, constant to IEC 60068-2-78 Damp heat, cyclic to IEC 60068-2-30
Ambient temperature		°C	
Open		°C	- 25 - 50

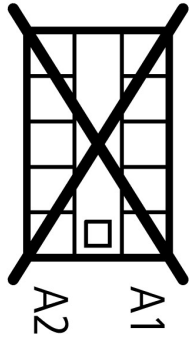
Enclosed		°C	- 25 - 40	
Mounting position			As required except vertical with terminals A1/A2 at the bottom	
Mounting position			As required, except vertical with terminals A1/A2 at the bottom	
Mechanical shock resistance (IEC/EN 60068-2-27)				
Half-sinusoidal shock, 10 ms				
Basic unit without auxiliary contact module				
Main contacts, make contacts		g	10	
Main contacts Make/break contacts		g	10 / 8	
Basic unit with auxiliary contact module				
Main contacts make contact		g		
Make		g	10	
Auxiliary contacts Make/break contacts		g	20 / 20	
Protection type			IP20	
Protection against direct contact when actuated from front (EN 90274)			Finger and back-ofhand proof	
Weight		kg	0.17	
Terminal capacity of auxiliary and main contacts				
Solid		mm ²	1 x (0.75 - 2.5) 2 x (0.75 - 2.5)	
Flexible with ferrule		mm ²	1 x (0.75 - 1.5) 2 x (0.75 - 1.5)	
Solid or stranded		AWG	18 - 14	
Terminal screw			M3.5	
Pozidriv screwdriver		Size	2	
Standard screwdriver		mm	0.8 x 5.5 1 x 6	
Max. tightening torque		Nm	1.2	
Terminal capacity springloaded terminals main and control circuits				
Solid		mm ²	1 x (1 - 2.5) 2 x (1 - 2.5)	
Flexible with ferrule		mm ²	1 x (1 - 2.5) 2 x (1 - 2.5)	
Standard screwdriver		mm	0.6 x 3.5	
Main conducting paths				
Rated impulse withstand voltage	U _{imp}	V AC	6000	
Overvoltage category/pollution degree			III/3	
Rated insulation voltage	U _i	V AC	690	
Rated operational voltage	U _e	V AC	690	
Safe isolation to VDE 0106 Part 101 and Part 101/A1				
between coil and contacts		V AC	300	
between the contacts		V AC	300	
Making capacity (cos φ to IEC/EN 60947)		A	110	
Breaking capacity				
220/230 V		A	90	
380/400 V		A	90	
500 V		A	64	
660/690 V		A	42	

Short-circuit protection maximum fuse			
Type "2" coordination	gL/gG	A	10
Type "1" coordination	gL/gG	A	20

AC

AC-1 duty			
Conventional free air thermal current, 3 pole, 50 - 60 Hz			
Open			
at 40 °C	$I_{th}=I_e$	A	22
at 50 °C	$I_{th}=I_e$	A	20
at 55 °C	$I_{th}=I_e$	A	19
enclosed	I_{th}	A	16
Notes			At maximum permissible ambient air temperature.
Conventional free air thermal current, 1 pole			
Notes			At maximum permissible ambient air temperature.
open	I_{th}	A	50
enclosed	I_{th}	A	40
AC-3 duty			
Rated operational current AC-3 open, 50 - 60 Hz, 3 pole			
Notes	I_e		At maximum permissible ambient air temperature.
220/230 V	I_e	A	9
240 V	I_e	A	9
380/400 V	I_e	A	9
415 V	I_e	A	9
440V	I_e	A	9
500 V	I_e	A	6.4
660/690 V	I_e	A	4.8
Motor rating	P	kWh	
220/230 V	P	kW	2.2
240V	P	kW	2.5
380/400 V	P	kW	4
415 V	P	kW	4.3
440 V	P	kW	4
500 V	P	kW	4
660/690 V	P	kW	4
AC-4 duty			
Rated operational current AC-4 open, 50 - 60 Hz, 3 pole			
Notes	I_e		At maximum permissible ambient air temperature.
220/230 V	I_e	A	6.6
240 V	I_e	A	6.6
380/400 V	I_e	A	6.6
415 V	I_e	A	6.6
440 V	I_e	A	6.6
500 V	I_e	A	5
660/690 V	I_e	A	3.4
Motor rating	P	kWh	
220/230 V	P	kW	1.5
240 V	P	kW	1.8
380/400 V	P	kW	3
415 V	P	kW	3.1
440 V	P	kW	3
500 V	P	kW	3
660/690 V	P	kW	3

DC

Rated operational current, open	I_e		
---------------------------------	-------	--	--

DC - -1			
12 V	I_e	A	20
24 V	I_e	A	20
60 V	I_e	A	20
110 V	I_e	A	20
220 V	I_e	A	20
DC - 3			
12 V	I_e	A	8
24 V	I_e	A	8
60 V	I_e	A	4
110 V	I_e	A	3
DC - 5			
12 V	I_e	A	2.5
24 V	I_e	A	2.5
60 V	I_e	A	2.5
110 V	I_e	A	1.5
220 V	I_e	A	0.3
Current heat losses (3- or 4-pole)			
to I_{th}		W	3.5
at I_e to AC-3/400 V		W	0.7

Magnet systems

Voltage tolerance		$x U_c$	
DC operated	Pick-up	$x U_c$	0.8 - 1.1
Power consumption			
DC operation			
Power consumption Pick-up = Sealing		VA/ W	2.6
Notes			Smoothed DC voltage or three-phase bridge rectifier
Duty factor		% DF	100
Switching times at 100 % U_c			
Make contact		ms	
Closing delay		ms	
Closing delay min.		ms	26
Closing delay max.		ms	35
Opening delay		ms	
Opening delay min.		ms	15
Opening delay max.		ms	25
Closing delay with top mounting auxiliary contact		ms	max. 70
Reversing contactors			
Changeover time at 110 % U_c		ms	
Changeover time min.		ms	40
Changeover time max.		ms	50
Arcing time at 690 V AC		ms	max. 12

Auxiliary contacts

Positive operating contacts to ZH 1/457, including auxiliary contact module			Yes
Rated impulse withstand voltage	U_{imp}	V AC	6000
Rated insulation voltage	U_i	V AC	690
Rated operational voltage	U_e	V	
Rated operational voltage	U_e	V AC	600
Safe isolation to VDE 0106 Part 101 and Part 101/A1			
between coil and auxiliary contacts		V AC	300

between the auxiliary contacts		V AC	300
Rated operational current	I_e	A	
AC-15			
220/240 V	I_e	A	6
380/415 V	I_e	A	3
500 V	I_e	A	1.5
DC-13			
Contacts in series:		A	
1	24 V	A	2.5
2	60 V	A	2.5
3	100 V	A	1.5
3	220 V	A	0.5
Control circuit reliability (at $U_e = 24$ V DC, $U_{min} = 17$ V, $I_{min} = 5.4$ mA)	Failure rate	λ	$<10^{-8}$, < one failure at 100 million operations
Component lifespan at $U_e = 240$ V			
AC-15	Operations	$\times 10^6$	0.2
DC-13			
L/R = 50 ms: 2 contacts in series at $I_e = 0.5$ A	Operations	$\times 10^6$	0.15
Notes			Switch-on and switch-off conditions based on DC-13, time constant as specified
Short-circuit rating without welding			
Maximum overcurrent protective device			
Short-circuit protection only			PKZM0-4
Short-circuit protection maximum fuse			
500 V		A gG/ gL	6
500 V		A fast	10
Current heat loss at I_{th}			
Per contact		W	0.3

Technical data according to ETIM 4.0

Number of main contacts as N/Os			3
Rated operation current I_e at AC-1, 400 V			22
Connection type main circuit			Screw connection
Rated control voltage U_s at AC 60HZ		V	0
Number of auxiliary contacts as N/Os			1
Rated control voltage U_s at AC 50HZ		V	0
Number of auxiliary contacts as N/Cs			0
Suitable for rail-mounting			No
Rated control voltage U_s at DC		V	24
Voltage type for actuation			DC
Rated operation current I_e at AC-3, 400 V		A	9
Number of N/Cs as main contact			0
Motor rating at AC-3, 400 V		kWh	4

Characteristics

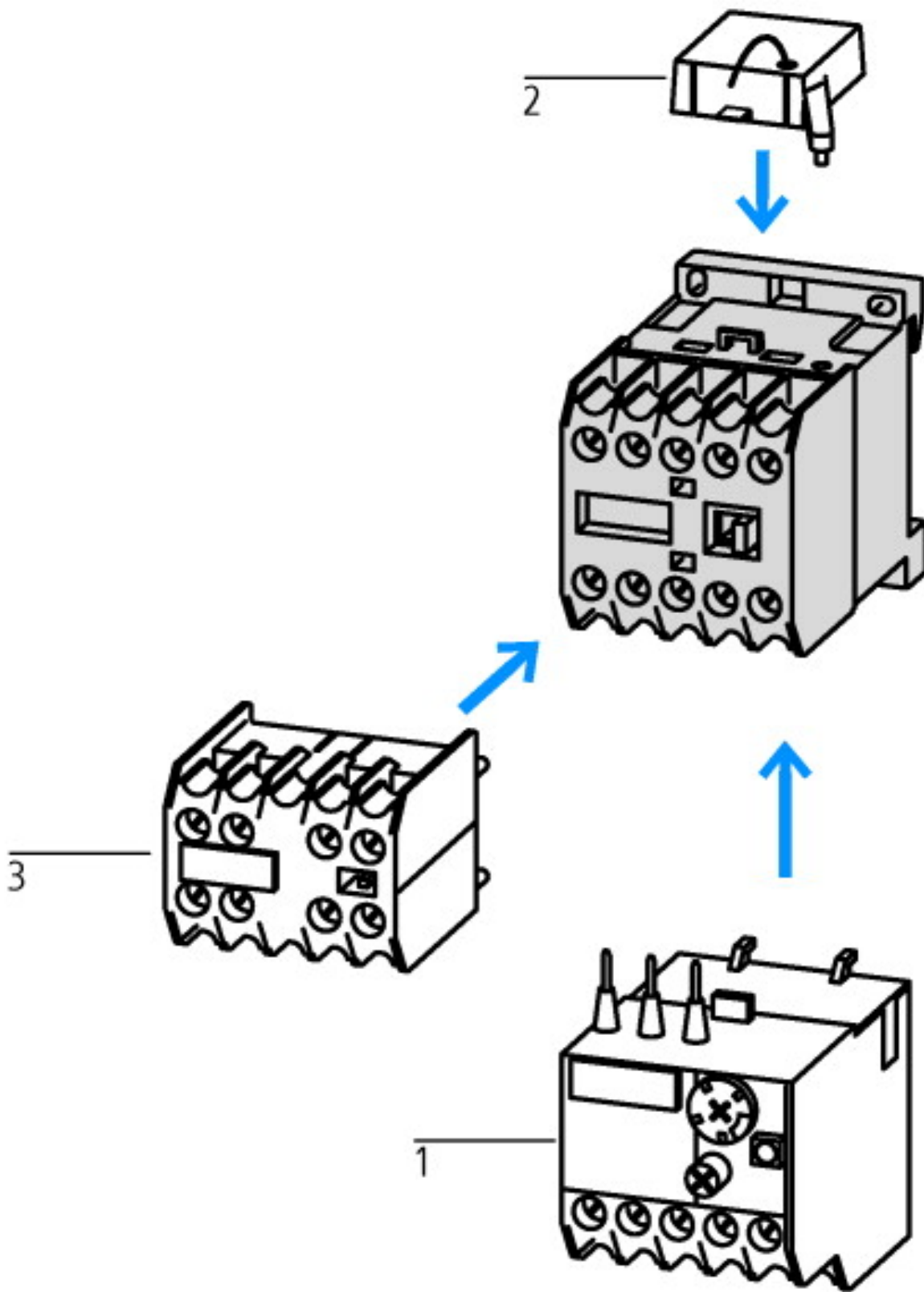

1: Overload relay
 2: Suppressor
 3: Auxiliary contact modules
 Enclosure totally insulated



- Squirrel-cage motor
- Operating characteristics
- Starting: from rest
- Stopping: after attaining full running speed
- Electrical characteristics
- Make: up to 6 x rated motor current
- Break: up to 1 x rated motor current
- Utilization category
- 100 % AC-3
- Typical applications
- Compressors
- Lifts
- Mixers
- Pumps
- Escalators
- Agitators
- Fans
- Conveyor belts
- Centrifuges
- Hinged flaps
- Bucket-elevators
- Air conditioning system
- General drives in manufacturing and processing machines

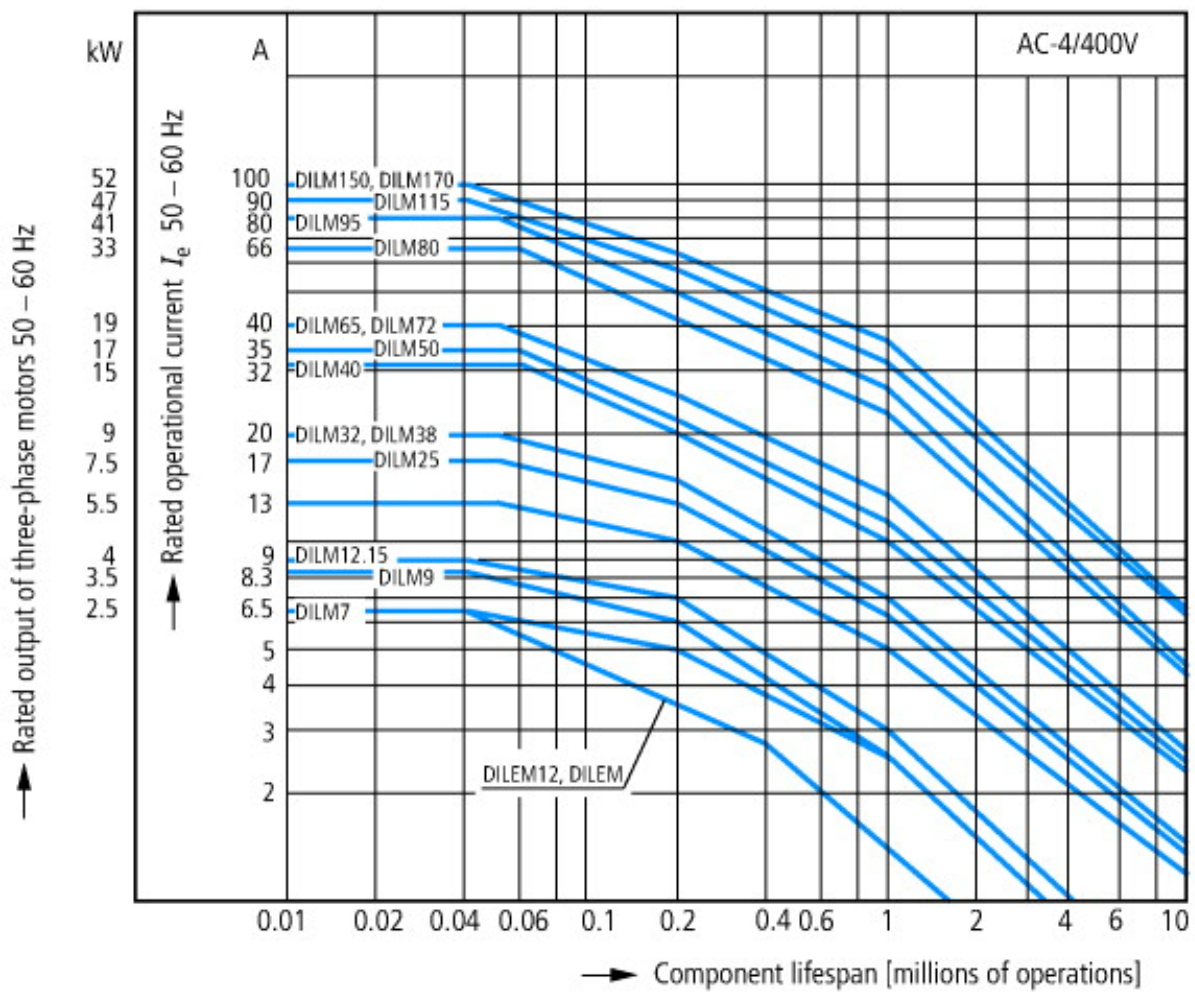

- Extreme switching duty
- Squirrel-cage motor
- Operating characteristics
- Inching, plugging, reversing
- Electrical characteristics
- Make: up to 6 x rated motor current
- Break: up to 6 x rated motor current
- Utilization category
- 100 % AC-4
- Typical applications
- Printing presses
- Wire-drawing machines
- Centrifuges
- Special drives for manufacturing and processing machines

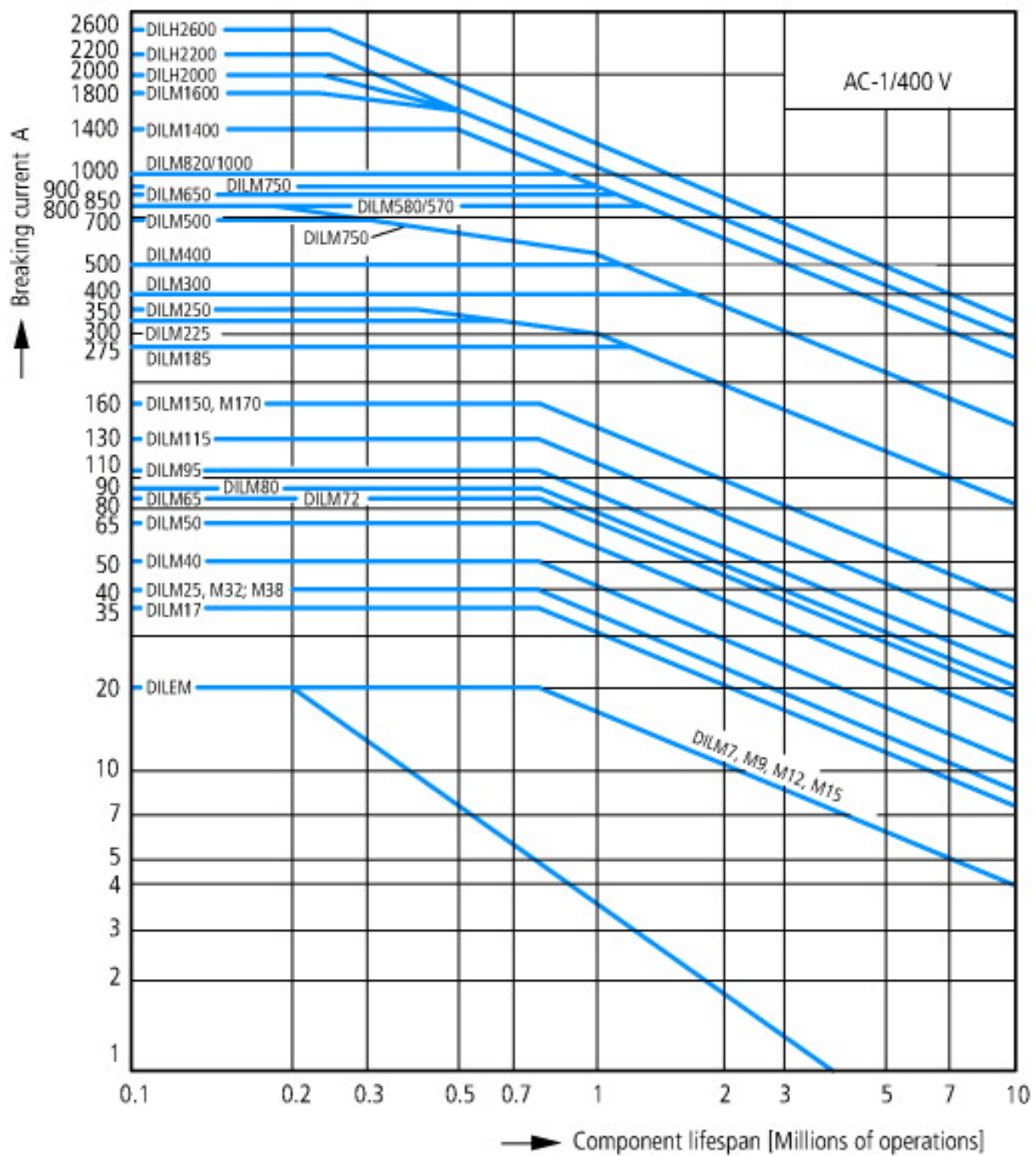

Switching duty for non-motor loads, 3-pole, 4-pole
 Operating characteristics
 Non-inductive or slightly inductive loads
 Electrical characteristics
 Make: 1 x rated current
 Break: 1 x rated current
 Utilization category
 100 % AC-1
 Typical applications
 Electric heat

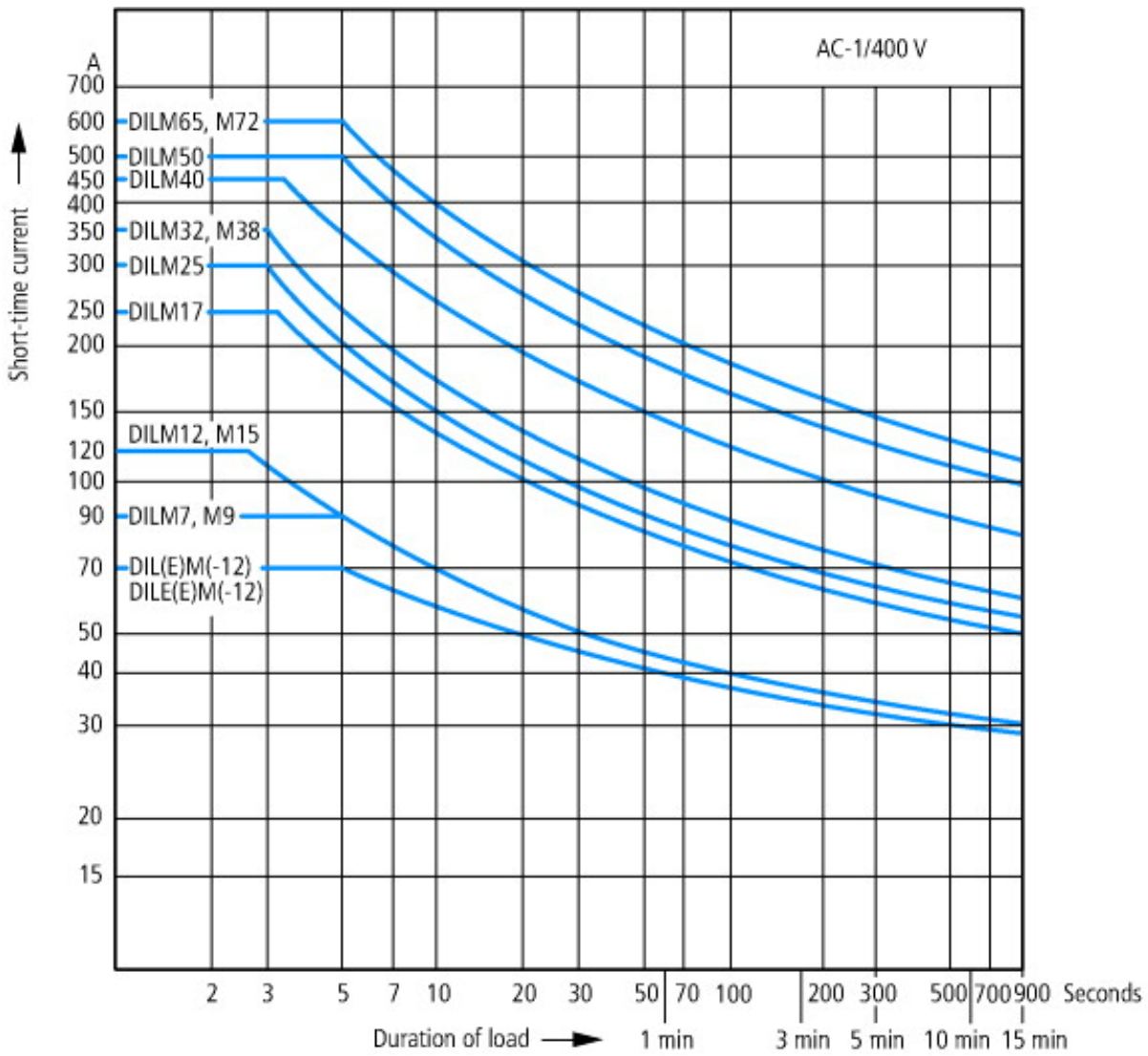

Short-time loading, 3-pole
Time interval between two loading cycles: 15 minutes

CAD-Data

Product standards CAD data:

<http://eaton-moeller.partcommunity.com>

Dimensions

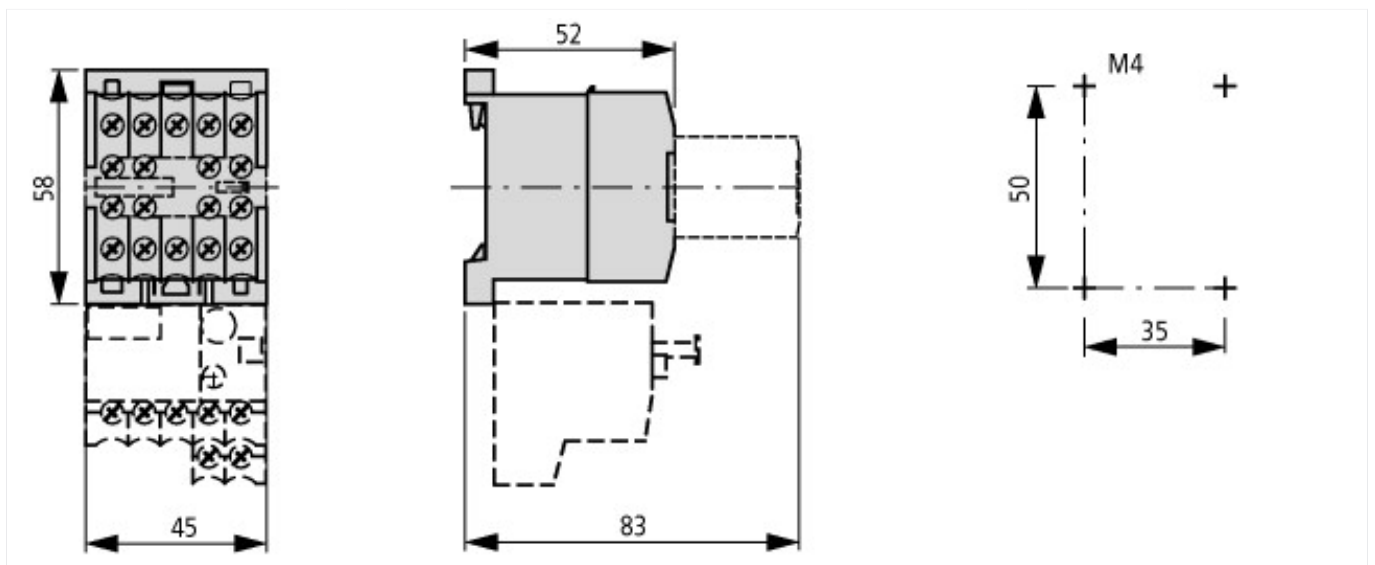

Additional product information (links)

IL03407009Z (IL03407009Z) Mini contactor relay

ftp://ftp.moeller.net/DOCUMENTATION/AWA_INSTRUCTIONS/IL03407009Z2010_10.pdf

