

General-Purpose AC Servo

MITSUBISHI SERVO AMPLIFIERS & MOTORS
MELSERVO-J4

SSCNET III/H Interface Multi-axis AC Servo
MODEL

MR-J4W2- _ B

MR-J4W3- _ B

SERVO AMPLIFIER INSTRUCTION MANUAL

● Safety Instructions ●

Please read the instructions carefully before using the equipment.

To use the equipment correctly, do not attempt to install, operate, maintain, or inspect the equipment until you have read through this Instruction Manual, Installation guide, and appended documents carefully. Do not use the equipment until you have a full knowledge of the equipment, safety information and instructions. In this Instruction Manual, the safety instruction levels are classified into "WARNING" and "CAUTION".



Indicates that incorrect handling may cause hazardous conditions, resulting in death or severe injury.



Indicates that incorrect handling may cause hazardous conditions, resulting in medium or slight injury to personnel or may cause physical damage.

Note that the CAUTION level may lead to a serious consequence according to conditions. Please follow the instructions of both levels because they are important to personnel safety. What must not be done and what must be done are indicated by the following diagrammatic symbols.



Indicates what must not be done. For example, "No Fire" is indicated by .



Indicates what must be done. For example, grounding is indicated by .

In this Instruction Manual, instructions at a lower level than the above, instructions for other functions, and so on are classified into "POINT".

After reading this Instruction Manual, keep it accessible to the operator.

1. To prevent electric shock, note the following

WARNING

- Before wiring and inspections, turn off the power and wait for 15 minutes or more until the charge lamp turns off. Then, confirm that the voltage between P+ and N- is safe with a voltage tester and others. Otherwise, an electric shock may occur. In addition, when confirming whether the charge lamp is off or not, always confirm it from the front of the servo amplifier.
- Ground the servo amplifier and servo motor securely.
- Any person who is involved in wiring and inspection should be fully competent to do the work.
- Do not attempt to wire the servo amplifier and servo motor until they have been installed. Otherwise, it may cause an electric shock.
- Do not operate switches with wet hands. Otherwise, it may cause an electric shock.
- The cables should not be damaged, stressed, loaded, or pinched. Otherwise, it may cause an electric shock.
- To prevent an electric shock, always connect the protective earth (PE) terminal (marked \oplus) of the servo amplifier to the protective earth (PE) of the cabinet.
- When using a residual current device (RCD), select the type B.
- To avoid an electric shock, insulate the connections of the power supply terminals.

2. To prevent fire, note the following

CAUTION

- Install the servo amplifier, servo motor, and regenerative resistor on incombustible material. Installing it directly or close to combustibles will lead to a fire.
- Always connect a magnetic contactor between the power supply and the main circuit power supply (L1, L2, and L3) of the servo amplifier, in order to configure a circuit that shuts down the power supply on the side of the servo amplifier's power supply. If a magnetic contactor is not connected, continuous flow of a large current may cause a fire when the servo amplifier malfunctions.
- When using the regenerative resistor, switch power off with the alarm signal. Not doing so may cause a fire when a regenerative transistor malfunctions or the like may overheat the regenerative resistor.
- Provide adequate protection to prevent screws and other conductive matter, oil and other combustible matter from entering the servo amplifier and servo motor.
- Always connect a molded-case circuit breaker to the power supply of the servo amplifier.

3. To prevent injury, note the following

CAUTION

- Only the voltage specified in the Instruction Manual should be applied to each terminal. Otherwise, a burst, damage, etc. may occur.
- Connect cables to the correct terminals. Otherwise, a burst, damage, etc. may occur.
- Ensure that polarity (+/-) is correct. Otherwise, a burst, damage, etc. may occur.
- The servo amplifier heat sink, regenerative resistor, servo motor, etc. may be hot while power is on or for some time after power-off. Take safety measures, e.g. provide covers, to prevent accidental contact of hands and parts (cables, etc.) with them.

4. Additional instructions

The following instructions should also be fully noted. Incorrect handling may cause a malfunction, injury, electric shock, etc.

(1) Transportation and installation

CAUTION

- Transport the products correctly according to their mass.
- Stacking in excess of the specified number of product packages is not allowed.
- Install the servo amplifier and the servo motor in a load-bearing place in accordance with the Instruction Manual.
- Do not get on or put heavy load on the equipment.
- The equipment must be installed in the specified direction.
- Leave specified clearances between the servo amplifier and the cabinet walls or other equipment.
- Do not install or operate the servo amplifier and servo motor which have been damaged or have any parts missing.
- When you keep or use the equipment, please fulfill the following environment.

Item		Environment
Ambient temperature	Operation	0 °C to 55 °C (non-freezing)
	Storage	-20 °C to 65 °C (non-freezing)
Ambient humidity	Operation	90% RH or less (non-condensing)
	Storage	
Ambience		Indoors (no direct sunlight), free from corrosive gas, flammable gas, oil mist, dust, and dirt
Altitude		Max. 1000 m above sea level
Vibration resistance		5.9 m/s ² at 10 Hz to 55 Hz (directions of X, Y, and Z axes)

- Do not block the intake and exhaust areas of the servo amplifier. Otherwise, it may cause a malfunction.
- Do not drop or strike the servo amplifier and servo motor. Isolate them from all impact loads.
- When the equipment has been stored for an extended period of time, contact your local sales office.
- When handling the servo amplifier, be careful about the edged parts such as corners of the servo amplifier.
- The servo amplifier must be installed in the metal cabinet.
- When you disinfect or protect wooden packing from insects, take measures except by fumigation. Fumigating the servo amplifier or packing the servo amplifier with fumigated wooden packing can cause a malfunction of the servo amplifier due to halogen materials (such as fluorine, chlorine, bromine, and iodine) which are contained in fumigant.
- The servo amplifier must not be used with parts which contain halogen-series flame retardant materials (such as bromine) under coexisting conditions.

(2) Wiring

CAUTION

- Wire the equipment correctly and securely. Otherwise, the servo motor may operate unexpectedly.
- Do not install a power capacitor, surge killer, or radio noise filter (FR-BIF option) on the servo amplifier output side.
- To avoid a malfunction, connect the wires to the correct phase terminals (U, V, and W) of the servo amplifier and servo motor.

⚠ CAUTION

- Connect the servo amplifier power output (U, V, and W) to the servo motor power input (U, V, and W) directly. Do not let a magnetic contactor, etc. intervene. Otherwise, it may cause a malfunction.

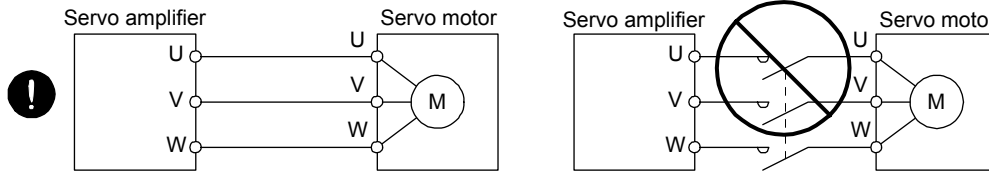

- The surge absorbing diode installed to the DC relay for control output should be fitted in the specified direction. Otherwise, the emergency stop and other protective circuits may not operate.

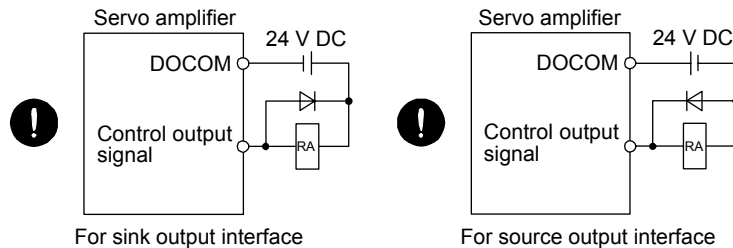

- When the cable is not tightened enough to the terminal block, the cable or terminal block may generate heat because of the poor contact. Be sure to tighten the cable with specified torque.
- Connecting an encoder for different axis to the CN2A, CN2B, or CN2C connector may cause a malfunction.
- Connecting a servo motor for different axis to the CNP3A, CNP3B, or CN3C connector may cause a malfunction.

(3) Test run and adjustment

⚠ CAUTION

- Before operation, check the parameter settings. Improper settings may cause some machines to perform unexpected operation.
- Never adjust or change the parameter values extremely as it will make operation unstable.
- Do not close to moving parts at servo-on status.

(4) Usage

⚠ CAUTION

- Provide an external emergency stop circuit to ensure that operation can be stopped and power switched off immediately.
- Do not disassemble, repair, or modify the equipment.
- Before resetting an alarm, make sure that the run signal of the servo amplifier is off in order to prevent a sudden restart. Otherwise, it may cause an accident.
- Use a noise filter, etc. to minimize the influence of electromagnetic interference. Electromagnetic interference may be given to the electronic equipment used near the servo amplifier.
- Burning or breaking a servo amplifier may cause a toxic gas. Do not burn or break it.
- Use the servo amplifier with the specified servo motor.

⚠ CAUTION

- The electromagnetic brake on the servo motor is designed to hold the motor shaft and should not be used for ordinary braking.
- For such reasons as service life and mechanical structure (e.g. where a ball screw and the servo motor are coupled via a timing belt), the electromagnetic brake may not hold the motor shaft. To ensure safety, install a stopper on the machine side.

(5) Corrective actions

⚠ CAUTION

- When it is assumed that a hazardous condition may occur due to a power failure or product malfunction, use a servo motor with an electromagnetic brake or external brake to prevent the condition.
- Configure an electromagnetic brake circuit so that it is activated also by an external EMG stop switch.

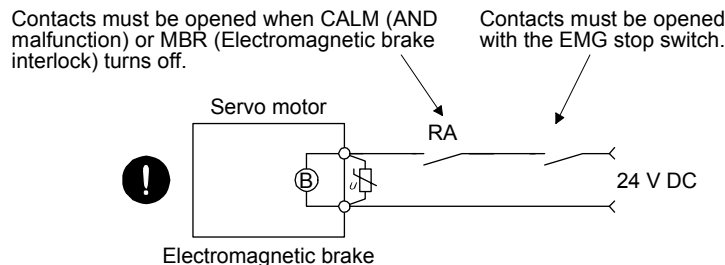

- When any alarm has occurred, eliminate its cause, ensure safety, and deactivate the alarm before restarting operation.
- Provide an adequate protection to prevent unexpected restart after an instantaneous power failure.

(6) Maintenance, inspection and parts replacement

⚠ CAUTION

- With age, the electrolytic capacitor of the servo amplifier will deteriorate. To prevent a secondary accident due to a malfunction, it is recommended that the electrolytic capacitor be replaced every 10 years when it is used in general environment. Please contact your local sales office.

(7) General instruction

- To illustrate details, the equipment in the diagrams of this Instruction Manual may have been drawn without covers and safety guards. When the equipment is operated, the covers and safety guards must be installed as specified. Operation must be performed in accordance with this Specifications and Instruction Manual.

● DISPOSAL OF WASTE ●

Please dispose a servo amplifier, battery (primary battery) and other options according to your local laws and regulations.

EEP-ROM life

The number of write times to the EEP-ROM, which stores parameter settings, etc., is limited to 100,000. If the total number of the following operations exceeds 100,000, the servo amplifier may malfunction when the EEP-ROM reaches the end of its useful life.

- Write to the EEP-ROM due to parameter setting changes
- Write to the EEP-ROM due to device changes

STO function of the servo amplifier

When using the STO function of the servo amplifier, refer to chapter 13.
For the MR-J3-D05 safety logic unit, refer to appendix 5.

Compliance with global standards

For the compliance with global standards, refer to appendix 4.

<<About the manuals>>

You must have this Instruction Manual and the following manuals to use this servo. Ensure to prepare them to use the servo safely.

Relevant manuals

Manual name	Manual No.
MELSERVO-J4W Series Instructions and Cautions for Safe Use of AC Servos (Packed with the servo amplifier)	IB(NA)0300176
MELSERVO-J4 SERVO AMPLIFIER INSTRUCTION MANUAL (TROUBLESHOOTING)	SH(NA)030109
MELSERVO Servo Motor Instruction Manual (Vol. 3) (Note 1)	SH(NA)030113
MELSERVO Linear Servo Motor Instruction Manual (Note 2)	SH(NA)030110
MELSERVO Direct Drive Motor Instruction Manual (Note 3)	SH(NA)030112
MELSERVO Linear Encoder Instruction Manual (Note 2, 4)	SH(NA)030111
EMC Installation Guidelines	IB(NA)67310

- Note
1. It is necessary for using a rotary servo motor.
 2. It is necessary for using a linear servo motor.
 3. It is necessary for using a direct drive motor.
 4. It is necessary for using a fully closed loop system.

<<Wiring>>

Wires mentioned in this Instruction Manual are selected based on the ambient temperature of 40 °C.

<<U.S. customary units>>

U.S. customary units are not shown in this manual. Convert the values if necessary according to the following table.

Quantity	SI (metric) unit	U.S. customary unit
Mass	1 [kg]	2.2046 [lb]
Length	1 [mm]	0.03937 [in]
Torque	1 [N·m]	141.6 [oz·in]
Moment of inertia	1 [(× 10 ⁻⁴ kg·m ²)]	5.4675 [oz·in ²]
Load (thrust load/axial load)	1 [N]	0.2248 [lbf]
Temperature	N [°C] × 9/5 + 32	N [°F]

CONTENTS

1. FUNCTIONS AND CONFIGURATION	1- 1 to 1-12
1.1 Summary.....	1- 1
1.2 Function block diagram.....	1- 2
1.3 Servo amplifier standard specifications	1- 3
1.3.1 Integrated 2-axis servo amplifier	1- 3
1.3.2 Integrated 3-axis servo amplifier	1- 5
1.3.3 Combinations of servo amplifiers and servo motors.....	1- 7
1.4 Function list.....	1- 8
1.5 Model designation.....	1- 9
1.6 Parts identification.....	1-10
1.7 Configuration including auxiliary equipment.....	1-11
2. INSTALLATION	2- 1 to 2- 6
2.1 Installation direction and clearances	2- 1
2.2 Keep out foreign materials.....	2- 3
2.3 Encoder cable stress	2- 3
2.4 SSCNET III cable laying	2- 3
2.5 Inspection items	2- 5
2.6 Parts having service lives	2- 6
3. SIGNALS AND WIRING	3- 1 to 3-38
3.1 Input power supply circuit	3- 2
3.2 I/O signal connection example.....	3- 5
3.2.1 For sink I/O interface.....	3- 5
3.2.2 For source I/O interface	3- 7
3.3 Explanation of power supply system	3- 8
3.3.1 Signal explanations	3- 8
3.3.2 Power-on sequence	3-10
3.3.3 Wiring CNP1, CNP2, and CNP3.....	3-11
3.4 Connectors and pin assignment	3-13
3.5 Signal (device) explanations.....	3-14
3.5.1 Input device	3-14
3.5.2 Output device	3-15
3.5.3 Output signal	3-18
3.5.4 Power supply.....	3-18
3.6 Forced stop deceleration function	3-19
3.6.1 Forced stop deceleration function (SS1).....	3-19
3.6.2 Base circuit shut-off delay time function	3-21
3.6.3 Vertical axis freefall prevention function	3-22
3.6.4 Residual risks of the forced stop function (EM2)	3-22
3.7 Alarm occurrence timing chart.....	3-23
3.7.1 When you use the forced stop deceleration function.....	3-23
3.7.2 When you do not use the forced stop deceleration function.....	3-24
3.8 Interfaces	3-25
3.8.1 Internal connection diagram.....	3-25

3.8.2 Detailed description of interfaces	3-26
3.8.3 Source I/O interfaces	3-27
3.9 SSCNET III cable connection	3-28
3.10 Servo motor with an electromagnetic brake	3-30
3.10.1 Safety precautions	3-30
3.10.2 Timing chart	3-32
3.11 Grounding	3-37

4. STARTUP	4- 1 to 4-20
-------------------	---------------------

4.1 Switching power on for the first time	4- 2
4.1.1 Startup procedure	4- 2
4.1.2 Wiring check	4- 3
4.1.3 Surrounding environment	4- 4
4.2 Startup	4- 4
4.3 Switch setting and display of the servo amplifier	4- 6
4.3.1 Switches	4- 6
4.3.2 Scrolling display	4-11
4.3.3 Status display of an axis	4-12
4.4 Test operation	4-14
4.5 Test operation mode	4-14
4.5.1 Test operation mode in MR Configurator2	4-15
4.5.2 Motor-less operation in controller	4-17

5. PARAMETERS	5- 1 to 5-50
----------------------	---------------------

5.1 Parameter list	5- 1
5.1.1 Basic setting parameters ([Pr. PA_ _])	5- 2
5.1.2 Gain/filter setting parameters ([Pr. PB_ _])	5- 3
5.1.3 Extension setting parameters ([Pr. PC_ _])	5- 4
5.1.4 I/O setting parameters ([Pr. PD_ _])	5- 6
5.1.5 Extension setting 2 parameters ([Pr. PE_ _])	5- 7
5.1.6 Extension setting 3 parameters ([Pr. PF_ _])	5- 9
5.1.7 Linear servo motor/DD motor setting parameters ([Pr. PL_ _])	5-10
5.2 Detailed list of parameters	5-12
5.2.1 Basic setting parameters ([Pr. PA_ _])	5-12
5.2.2 Gain/filter setting parameters ([Pr. PB_ _])	5-21
5.2.3 Extension setting parameters ([Pr. PC_ _])	5-34
5.2.4 I/O setting parameters ([Pr. PD_ _])	5-38
5.2.5 Extension setting 2 parameters ([Pr. PE_ _])	5-42
5.2.6 Extension setting 3 parameters ([Pr. PF_ _])	5-44
5.2.7 Linear servo motor/DD motor setting parameters ([Pr. PL_ _])	5-46

6. NORMAL GAIN ADJUSTMENT	6- 1 to 6-20
----------------------------------	---------------------

6.1 Different adjustment methods	6- 1
6.1.1 Adjustment on a single servo amplifier	6- 1
6.1.2 Adjustment using MR Configurator2	6- 2
6.2 One-touch tuning	6- 3
6.2.1 One-touch tuning flowchart	6- 3
6.2.2 Display transition and operation procedure of one-touch tuning	6- 4

6.2.3 Caution for one-touch tuning	6- 9
6.3 Auto tuning	6-10
6.3.1 Auto tuning mode	6-10
6.3.2 Auto tuning mode basis	6-11
6.3.3 Adjustment procedure by auto tuning	6-12
6.3.4 Response level setting in auto tuning mode	6-13
6.4 Manual mode	6-14
6.5 2 gain adjustment mode	6-17

7. SPECIAL ADJUSTMENT FUNCTIONS	7- 1 to 7-30
--	---------------------

7.1 Filter setting	7- 1
7.1.1 Machine resonance suppression filter	7- 2
7.1.2 Adaptive filter II	7- 5
7.1.3 Shaft resonance suppression filter	7- 7
7.1.4 Low-pass filter	7- 8
7.1.5 Advanced vibration suppression control II	7- 8
7.1.6 Command notch filter	7-13
7.2 Gain switching function	7-15
7.2.1 Applications	7-15
7.2.2 Function block diagram	7-16
7.2.3 Parameter	7-17
7.2.4 Gain switching procedure	7-20
7.3 Tough drive function	7-23
7.3.1 Vibration tough drive function	7-23
7.3.2 Instantaneous power failure tough drive function	7-25
7.4 Compliance with SEMI-F47 standard	7-28

8. TROUBLESHOOTING	8- 1 to 8-10
---------------------------	---------------------

8.1 Alarm and warning list	8- 1
8.2 Troubleshooting at power on	8-10

9. OUTLINE DRAWINGS	9- 1 to 9- 6
----------------------------	---------------------

9.1 Servo amplifier	9- 1
9.2 Connector	9- 4

10. CHARACTERISTICS	10- 1 to 10-10
----------------------------	-----------------------

10.1 Overload protection characteristics	10- 1
10.2 Power supply capacity and generated loss	10- 2
10.3 Dynamic brake characteristics	10- 5
10.3.1 Dynamic brake operation	10- 6
10.3.2 Permissible load to motor inertia when the dynamic brake is used	10- 8
10.4 Cable bending life	10- 9
10.5 Inrush currents at power-on of main circuit and control circuit	10- 9

11. OPTIONS AND AUXILIARY EQUIPMENT	11- 1 to 11-36
--	-----------------------

11.1 Cable/connector sets	11- 1
---------------------------------	-------

11.1.1	Combinations of cable/connector sets	11- 2
11.1.2	SSCNET III cable	11- 5
11.1.3	Battery cable/junction battery cable	11- 7
11.1.4	MR-D05UDL3M-B STO cable	11- 8
11.2	Regenerative options	11- 8
11.2.1	Combination and regenerative power	11- 8
11.2.2	Selection of regenerative option	11- 9
11.2.3	Parameter setting	11-11
11.2.4	Connection of regenerative option	11-12
11.2.5	Dimensions	11-13
11.3	MR-BT6VCASE battery case and MR-BAT6V1 battery	11-14
11.4	MR Configurator2	11-15
11.5	Selection example of wires	11-17
11.6	Molded-case circuit breakers, fuses, magnetic contactors (recommended).....	11-19
11.7	Power factor improving AC reactors	11-20
11.8	Relays (recommended)	11-21
11.9	Noise reduction techniques	11-21
11.10	Earth-leakage current breaker	11-28
11.11	EMC filter (recommended)	11-31
11.12	Junction terminal block MR-TB26A	11-34

12. ABSOLUTE POSITION DETECTION SYSTEM	12- 1 to 12- 8
---	-----------------------

12.1	Features	12- 1
12.2	Specifications	12- 2
12.3	Assembling a battery unit	12- 5
12.3.1	Required items	12- 5
12.3.2	Disassembly and assembly of the battery case MR-BT6VCASE	12- 5
12.3.3	Battery cable removal	12- 7
12.4	Confirmation of absolute position detection data	12- 8

13. USING STO FUNCTION	13- 1 to 13-14
-------------------------------	-----------------------

13.1	Introduction	13- 1
13.1.1	Summary	13- 1
13.1.2	Terms related to safety	13- 1
13.1.3	Cautions	13- 1
13.1.4	Residual risks of the STO function.....	13- 2
13.1.5	Specifications	13- 3
13.1.6	Maintenance.....	13- 4
13.2	STO I/O signal connector (CN8) and signal layouts.....	13- 4
13.2.1	Signal layouts	13- 4
13.2.2	Signal (device) explanations	13- 5
13.2.3	How to pull out the STO cable	13- 5
13.3	Connection example	13- 6
13.3.1	Connection example for CN8 connector	13- 6
13.3.2	External I/O signal connection example using an MR-J3-D05 safety logic unit	13- 7
13.3.3	External I/O signal connection example using an external safety relay unit	13- 9
13.3.4	External I/O signal connection example using a motion controller	13-10
13.4	Detailed description of interfaces	13-11
13.4.1	Sink I/O interface.....	13-11

13.4.2 Source I/O interface	13-12
-----------------------------------	-------

14. USING A LINEAR SERVO MOTOR	14- 1 to 14-32
---------------------------------------	-----------------------

14.1 Functions and configuration	14- 1
14.1.1 Summary	14- 1
14.1.2 Servo system with auxiliary equipment.....	14- 2
14.2 Signals and wiring.....	14- 3
14.3 Operation and functions.....	14- 5
14.3.1 Startup.....	14- 5
14.3.2 Magnetic pole detection	14- 8
14.3.3 Home position return.....	14-16
14.3.4 Test operation mode in MR Configurator2.....	14-19
14.3.5 Operation from controller	14-22
14.3.6 Function.....	14-24
14.3.7 Absolute position detection system.....	14-26
14.4 Characteristics	14-27
14.4.1 Overload protection characteristics	14-27
14.4.2 Power supply capacity and generated loss	14-28
14.4.3 Dynamic brake characteristics	14-30
14.4.4 Permissible load to motor mass ratio when the dynamic brake is used	14-31

15. USING A DIRECT DRIVE MOTOR	15- 1 to 15-20
---------------------------------------	-----------------------

15.1 Functions and configuration	15- 1
15.1.1 Summary	15- 1
15.1.2 Servo system with auxiliary equipment.....	15- 2
15.2 Signals and wiring.....	15- 3
15.3 Operation and functions.....	15- 4
15.3.1 Startup procedure	15- 5
15.3.2 Magnetic pole detection	15- 6
15.3.3 Operation from controller	15-14
15.3.4 Function.....	15-15
15.4 Characteristics	15-17
15.4.1 Overload protection characteristics	15-17
15.4.2 Power supply capacity and generated loss	15-18
15.4.3 Dynamic brake characteristics	15-19

16. FULLY CLOSED LOOP SYSTEM	16- 1 to 16-24
-------------------------------------	-----------------------

16.1 Functions and configuration	16- 1
16.1.1 Function block diagram.....	16- 1
16.1.2 Selecting procedure of control mode	16- 3
16.1.3 System configuration.....	16- 4
16.2 Load-side encoder	16- 5
16.2.1 Linear encoder	16- 5
16.2.2 Rotary encoder.....	16- 5
16.2.3 Configuration diagram of encoder cable.....	16- 5
16.2.4 MR-J4FCCBL03M branch cable.....	16- 6
16.3 Operation and functions.....	16- 7
16.3.1 Startup.....	16- 7

16.3.2 Home position return.....	16-14
16.3.3 Operation from controller	16-17
16.3.4 Fully closed loop control error detection functions.....	16-19
16.3.5 Auto tuning function	16-20
16.3.6 Machine analyzer function	16-20
16.3.7 Test operation mode	16-20
16.3.8 Absolute position detection system under fully closed loop system.....	16-21
16.3.9 About MR Configurator2	16-22

APPENDIX

App.- 1 to App.-51

App. 1 Auxiliary equipment manufacturer (for reference)	App.- 1
App. 2 Handling of AC servo amplifier batteries for the United Nations Recommendations on the Transport of Dangerous Goods	App.- 1
App. 3 Symbol for the new EU Battery Directive.....	App.- 3
App. 4 Compliance with overseas standards	App.- 3
App. 5 MR-J3-D05 Safety logic unit	App.-17
App. 6 EC declaration of conformity	App.-35
App. 7 How to replace servo amplifier without magnetic pole detection.....	App.-37
App. 8 Two-wire type encoder cable for HG-MR/HG-KR.....	App.-38
App. 9 SSCNET III cable (SC-J3BUS_M-C) manufactured by Mitsubishi Electric System & Service	App.-40
App. 10 CNP_crimping connector	App.-40
App. 11 Recommended cable for servo amplifier power supply	App.-41
App. 12 J3 compatibility mode.....	App.-42

1. FUNCTIONS AND CONFIGURATION

1. FUNCTIONS AND CONFIGURATION

1.1 Summary

The MELSERVO-J4 series of multi-axis servo amplifiers inherits the high performance, sophisticated functions, and usability of the MR-J4-B servo amplifiers, and ensures space saving, reduced wiring, and energy saving.

The MR-J4W_-B servo amplifier is connected to controllers, including a servo system controller, on the fast synchronization network, SSCNET III/H. The servo amplifier directly receives a command from a controller to drive a servo motor.

One MR-J4W_-B servo amplifier can drive two or three servo motors. The footprint of one MR-J4W_-B servo amplifier is considerably smaller than that of two or three MR-J4-B servo amplifiers. You can install MR-J4W_-B servo amplifiers without clearance between them. This makes your system more compact.

The multi-axis structure enables multiple axes to share the SSCNET III cable, control circuit power supply cable, and main circuit power supply cable. This ensures reduced wiring.

For the MR-J4W_-B servo amplifier, the parameter settings allow you to use a rotary servo motor, linear servo motor, and direct drive motor for each axis. The axes can be connected to a rotary servo motor, linear servo motor, and direct drive motor, which have different capacity. Using a linear servo motor or direct drive motor simplifies the system, and using the MR-J4W_-B servo amplifier downsizes the equipment, enhances the equipment performance, and ensures space saving.

Using regenerative energy generated when a servo motor decelerates ensures energy saving.

Depending on the operating conditions, the regenerative option is not required.

As the MR-J4-B servo amplifier, the MR-J4W_-B servo amplifier supports the one-touch adjustment and the real-time auto tuning. This enables you to easily adjust the servo gain according to the machine.

The tough drive function and the drive recorder function, which are well-received in the MELSERVO-JN series, have been improved. The MR-J4W_-B servo amplifier supports the improved functions. Additionally, the preventive maintenance support function detects an error in the machine parts. This function provides strong support for the machine maintenance and inspection.

On the SSCNET III/H network, the stations are connected with a maximum distance of 100 m between them. This allows you to create a large system.

The MR-J4W_-B servo amplifier supports the Safe Torque Off (STO) function for safety. When the MR-J4W_-B servo amplifier is connected to a SSCNET III/H-compatible motion controller, in addition to the STO function, the servo amplifier also supports the Safe Stop 1 (SS1), Safe Stop 2 (SS2), Safe Operating Stop (SOS), Safely-Limited Speed (SLS), Safe Brake Control (SBC), and Safe Speed Monitor (SSM) functions.

The MR-J4W_-B servo amplifier has a USB communication interface. Therefore, you can connect the servo amplifier to the personal computer with MR Configurator2 installed to perform the parameter setting, test operation, gain adjustment, and others.

1. FUNCTIONS AND CONFIGURATION

1.2 Function block diagram

The function block diagram of this servo is shown below.

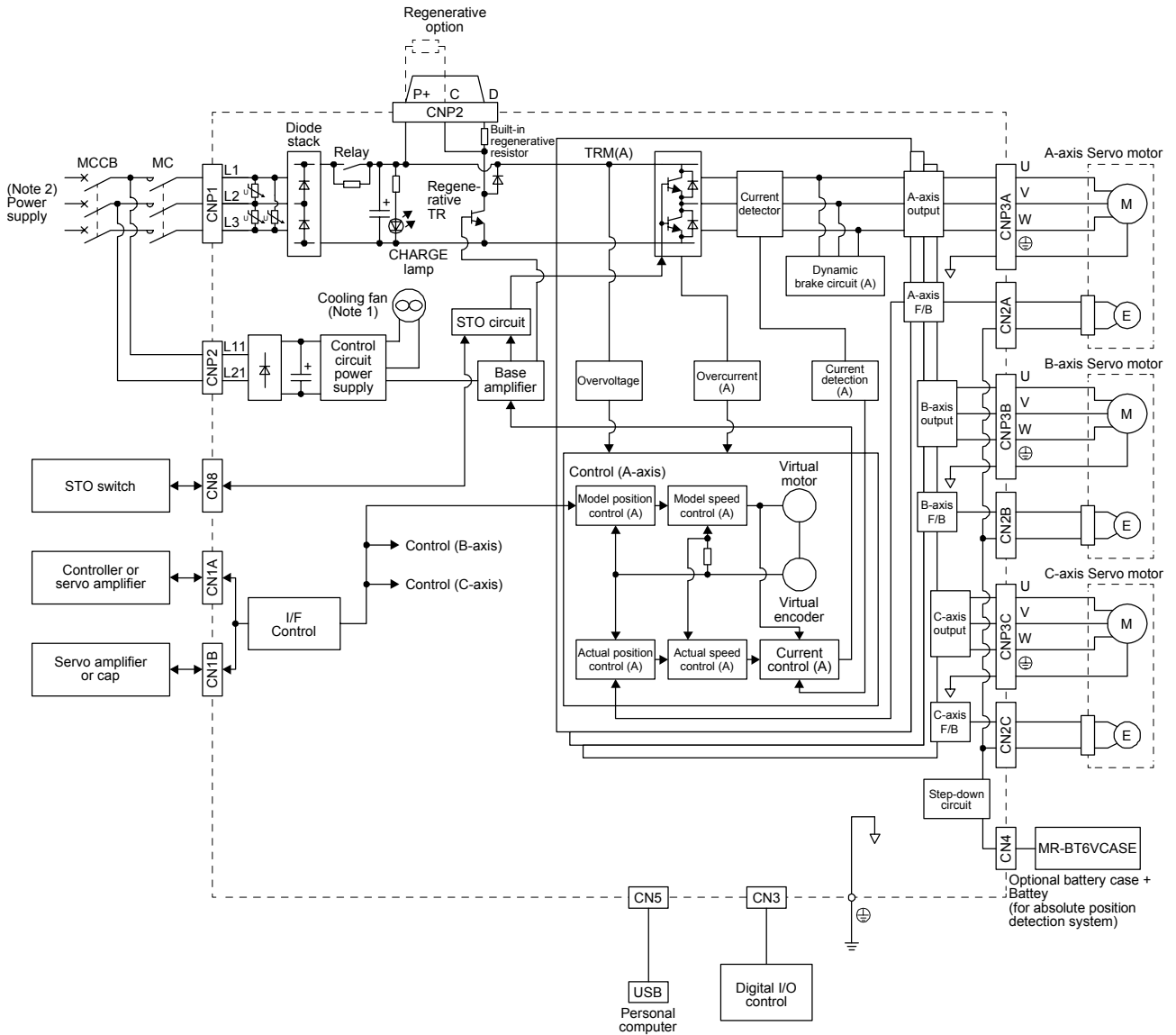

- Note 1. The MR-J4W2-22B has no cooling fan.
 Note 2. For 1-phase 200 V AC to 240 V AC, connect the power supply to L1 and L3. Leave L2 open. For the power supply specifications, refer to section 1.3.

1. FUNCTIONS AND CONFIGURATION

1.3 Servo amplifier standard specifications

1.3.1 Integrated 2-axis servo amplifier

Model MR-J4W2-		22B	44B	77B	1010B	
Output	Rated voltage	3-phase 170 V AC				
	Rated current (each axis) [A]	1.5	2.8	5.8	6.0	
Main circuit power supply	Voltage/Frequency	3-phase or 1-phase 200 V AC to 240 V AC, 50 Hz/60 Hz			3-phase 200 V AC to 240 V AC, 50 Hz/60 Hz	
	Rated current [A]	2.9	5.2	7.5	9.8	
	Permissible voltage fluctuation	3-phase or 1-phase 170 V AC to 264 V AC			3-phase 170 V AC to 264 V AC	
	Permissible frequency fluctuation	Within ±5%				
	Power supply capacity [kVA]	Refer to section 10.2.				
	Inrush current [A]	Refer to section 10.5.				
Control circuit power supply	Voltage/Frequency	1-phase 200 V AC to 240 V AC, 50 Hz/60 Hz				
	Rated current [A]	0.4				
	Permissible voltage fluctuation	1-phase 170 V AC to 264 V AC				
	Permissible frequency fluctuation	Within ±5%				
	Power consumption [W]	55				
	Inrush current [A]	Refer to section 10.5.				
Interface power supply	Voltage	24 V DC ± 10%				
	Power supply capacity	0.35 A (Note 1)				
Control method		Sine-wave PWM control, current control method				
Capacitor regeneration	Reusable regenerative energy (Note 2) [J]	17	21	44		
	Moment of inertia J equivalent to the permissible charging amount (Note 3) [$\times 10^{-4}$ kg \cdot m ²]	3.45	4.26	8.92		
	Mass equivalent to the permissible charging amount (Note 4) [kg]	LM-H3	3.8	4.7	9.8	
		LM-K2 LM-U2	8.5	10.5	22.0	
Built-in regenerative resistance [W]		20		100		
Dynamic brake		Built-in				
SSCNET III/H command communication cycle (Note 9)		0.222 ms, 0.444 ms, 0.888 ms				
Communication function		USB: Connect a personal computer (MR Configurator2 compatible)				
Encoder output pulse		Compatible (A/B-phase pulse)				
Analog monitor		None				
Fully closed loop control		Available (Note 8)				
Load-side encoder interface		Mitsubishi high-speed serial communication (Note 6)				
Protective functions		Overcurrent shut-off, regenerative overvoltage shut-off, overload shut-off (electronic thermal), servo motor overheat protection, encoder error protection, regenerative error protection, undervoltage protection, instantaneous power failure protection, overspeed protection, and error excessive protection				

1. FUNCTIONS AND CONFIGURATION

Model MR-J4W2-		22B	44B	77B	1010B
Safety function		STO (IEC/EN 61800-5-2) (Note 7)			
Safety performance	Standards certified by CB	EN ISO 13849-1 PL d (category 3), EN 61508 SIL 2, EN 62061 SIL CL2			
	Response performance	8 ms or less (STO input off → energy shut off)			
	(Note 5) Test pulse input (STO)	Test pulse interval: 1 Hz to 25 Hz Test pulse off time: Up to 1 ms			
	Mean time to dangerous failure (MTTFd)	100 years or longer			
	Diagnosis converge (DC)	Medium (90% to 99%)			
	Average probability of dangerous failures per hour (PFH)	1.68×10^{-10} [1/h]			
Compliance to standards	CE marking	LVD: EN 61800-5-1 EMC: EN 61800-3 MD: EN ISO 13849-1, EN 61800-5-2, EN 62061			
	UL standard	UL 508C			
Structure (IP rating)		Natural cooling, open (IP20)	Force cooling, open (IP20)		
Close mounting		Possible			
Environment	Ambient temperature	Operation	0 °C to 55 °C (non-freezing)		
		Storage	-20 °C to 65 °C (non-freezing)		
	Ambient humidity	Operation	90% RH or less (non-condensing)		
		Storage			
	Ambience	Indoors (no direct sunlight), free from corrosive gas, flammable gas, oil mist, dust, and dirt			
	Altitude	Max. 1000 m above sea level			
Vibration	5.9 m/s ² or less at 10 Hz to 55 Hz (directions of X, Y and Z axes)				
Mass [kg]		1.5	2.0		

- Note
- 0.35 A is the value applicable when all I/O signals are used. The current capacity can be decreased by reducing the number of I/O points.
 - Reusable regenerative energy corresponds to energy generated under the following conditions.
 Rotary servo motor: Regenerative energy is generated when the machine, whose moment of inertia is equivalent to the permissible charging amount, decelerates from the rated speed to stop.
 Linear servo motor: Regenerative energy is generated when the machine, whose mass is equivalent to the permissible charging amount, decelerates from the maximum speed to stop.
 Direct drive motor: Regenerative energy is generated when the machine, whose moment of inertia is equivalent to the permissible charging amount, decelerates from the rated speed to stop.
 - Moment of inertia when the motor decelerates from the rated speed to stop
 Moment of inertia for two axes when two motors decelerate simultaneously
 Moment of inertia for each axis when multiple motors do not decelerate simultaneously
 The values also apply to the direct drive motor.
 - Mass when the machine decelerates from the maximum speed to stop
 The primary-side (coil) mass is included.
 Mass for two axes when two motors decelerate simultaneously
 Mass for each axis when multiple motors do not decelerate simultaneously
 - Test pulse is a signal which instantaneously turns off a signal to the servo amplifier at a constant period for external circuit to self-diagnose.
 - The load-side encoder is compatible only with two-wire type communication method. Not compatible with pulse train interface (A/B/Z-phase differential output type).
 - STO is common for all axes.
 - Fully closed loop control is compatible with the servo amplifiers with software version A3 or later.
 Check the software version of the servo amplifier using MR Configurator2.
 - The command communication cycle depends on the controller specifications and the number of axes connected.

1. FUNCTIONS AND CONFIGURATION

1.3.2 Integrated 3-axis servo amplifier

Model MR-J4W3-		222B	444B	
Output	Rated voltage	3-phase 170 V AC		
	Rated current (each axis) [A]	1.5	2.8	
Main circuit power supply input	Power supply /Frequency	3-phase or 1-phase 200 V AC to 240 V AC, 50 Hz/60 Hz		
	Rated current [A]	4.3	7.8	
	Permissible voltage fluctuation	3-phase or 1-phase 170 V AC to 264 V AC, 50 Hz/60 Hz		
	Permissible frequency fluctuation	Within $\pm 5\%$		
	Power supply capacity [kVA]	Refer to section 10.2.		
	Inrush current [A]	Refer to section 10.5.		
Control circuit power supply input	Power supply /Frequency	1-phase 200 V AC to 240 V AC, 50 Hz/60 Hz		
	Rated current [A]	0.4		
	Permissible voltage fluctuation	1-phase 170 V AC to 264 V AC		
	Permissible frequency fluctuation	Within $\pm 5\%$		
	Power consumption [W]	55		
	Inrush current [A]	Refer to section 10.5.		
Interface power supply	Voltage/Frequency	24 V DC $\pm 10\%$		
	Power supply capacity	0.45 A (Note 1)		
Control method		Sine-wave PWM control, current control method		
Capacitor regeneration	Reusable regenerative energy (Note 2) [J]	21	30	
	Moment of inertia J equivalent to the permissible charging amount (Note 3) [$\times 10^{-4}$ kg \cdot m ²]	4.26	6.08	
	Mass equivalent to the permissible charging amount (Note 4) [kg]	LM-H3	4.7	6.7
		LM-K2 LM-U2	10.5	15.0
Built-in regenerative resistance [W]		30	100	
Dynamic brake		Built-in		
SSCNET III/H command communication cycle (Note 7)		0.222 ms (Note 8), 0.444 ms, 0.888 ms		
Communication function		USB: Connect a personal computer (MR Configurator2 compatible)		
Encoder output pulse		Not compatible		
Analog monitor		None		
Fully closed loop control		Not compatible		
Protective functions		Overcurrent shut-off, regenerative overvoltage shut-off, overload shut-off (electronic thermal), servo motor overheat protection, encoder error protection, regenerative error protection, undervoltage protection, instantaneous power failure protection, overspeed protection, and error excessive protection		

1. FUNCTIONS AND CONFIGURATION

Model MR-J4W3-		222B	444B	
Safety function		STO (IEC/EN 61800-5-2) (Note 6)		
Safety performance	Standards certified by CB	EN ISO 13849-1 PL d (category 3), EN 61508 SIL 2, EN 62061 SIL CL2		
	Response performance	8 ms or less (STO input off → energy shut off)		
	(Note 5) Test pulse input (STO)	Test pulse interval: 1 Hz to 25 Hz Test pulse off time: Up to 1 ms		
	Mean time to dangerous failure (MTTFd)	100 years or longer		
	Diagnosis converge (DC)	Medium (90% to 99%)		
	Average probability of dangerous failures per hour (PFH)	1.68×10^{-10} [1/h]		
Compliance to standards	CE marking	LVD: EN 61800-5-1 EMC: EN 61800-3 MD: EN ISO 13849-1, EN 61800-5-2, EN 62061		
	UL standard	UL 508C		
Structure (IP rating)		Force cooling, open (IP20)		
Close mounting		Possible		
Environment	Ambient temperature	Operation	0 °C to 55 °C (non-freezing)	
		Storage	-20 °C to 65 °C (non-freezing)	
	Ambient humidity	Operation	90% RH or less (non-condensing)	
		Storage		
	Ambience	Indoors (no direct sunlight), free from corrosive gas, flammable gas, oil mist, dust, and dirt		
	Altitude	Max. 1000 m above sea level		
Vibration	5.9 m/s ² or less at 10 Hz to 55 Hz (directions of X, Y and Z axes)			
Mass [kg]		1.9		

- Note 1. 0.45 A is the value applicable when all I/O signals are used. The current capacity can be decreased by reducing the number of I/O points.
2. Reusable regenerative energy corresponds to energy generated under the following conditions.
 Rotary servo motor: Regenerative energy is generated when the machine, whose moment of inertia is equivalent to the permissible charging amount, decelerates from the rated speed to stop.
 Linear servo motor: Regenerative energy is generated when the machine, whose mass is equivalent to the permissible charging amount, decelerates from the maximum speed to stop.
 Direct drive motor: Regenerative energy is generated when the machine, whose moment of inertia is equivalent to the permissible charging amount, decelerates from the rated speed to stop.
3. Moment of inertia when the machine decelerates from the rated speed to stop
 Moment of inertia for three axes when three motors decelerate simultaneously
 Moment of inertia for each axis when multiple motors do not decelerate simultaneously
 The values also apply to the direct drive motor.
4. Mass when the machine decelerates from the maximum speed to stop
 The primary-side (coil) mass is included.
 Mass for three axes when three motors decelerate simultaneously
 Mass for each axis when multiple motors do not decelerate simultaneously
5. Test pulse is a signal which instantaneously turns off a signal to the servo amplifier at a constant period for external circuit to self-diagnose.
6. STO is common for all axes.
7. The command communication cycle depends on the controller specifications and the number of axes connected.
8. Servo amplifier with software version A3 or later is compatible with the command communication cycle of 0.222 ms. However, note that the following functions are not available when 0.222 ms is used: auto tuning (real time, one-touch, and vibration suppression control), adaptive filter II, vibration tough drive, and power monitoring.

1. FUNCTIONS AND CONFIGURATION

1.3.3 Combinations of servo amplifiers and servo motors

(1) With MR-J4W2-B servo amplifier

Servo amplifier	Rotary servo motor					Linear servo motor (primary side)	Direct drive motor
	HG-KR	HG-MR	HG-SR	HG-UR	HG-JR		
MR-J4W2-22B	053 13 23	053 13 23				LM-U2PAB-05M-0SS0 LM-U2PBB-07M-1SS0	TM-RFM002C20
MR-J4W2-44B	053 13 23 43	053 13 23 43				LM-H3P2A-07P-BSS0 LM-H3P3A-12P-CSS0 LM-K2P1A-01M-2SS1 LM-U2PAB-05M-0SS0 LM-U2PAD-10M-0SS0 LM-U2PAF-15M-0SS0 LM-U2PBB-07M-1SS0	TM-RFM002C20 TM-RFM004C20
MR-J4W2-77B	43 73	43 73	51 52	72	53 73	LM-H3P2A-07P-BSS0 LM-H3P3A-12P-CSS0 LM-H3P3B-24P-CSS0 LM-H3P3C-36P-CSS0 LM-H3P7A-24P-ASS0 LM-K2P1A-01M-2SS1 LM-K2P2A-02M-1SS1 LM-U2PAD-10M-0SS0 LM-U2PAF-15M-0SS0 LM-U2PBD-15M-1SS0 LM-U2PBF-22M-1SS0	TM-RFM004C20 TM-RFM006C20 TM-RFM006E20 TM-RFM012E20 TM-RFM012G20 TM-RFM040J10
MR-J4W2-1010B	43 73	43 73	51 81 52 102	72	53 (Note) 73 103	LM-H3P2A-07P-BSS0 LM-H3P3A-12P-CSS0 LM-H3P3B-24P-CSS0 LM-H3P3C-36P-CSS0 LM-H3P7A-24P-ASS0 LM-K2P1A-01M-2SS1 LM-K2P2A-02M-1SS1 LM-U2PAD-10M-0SS0 LM-U2PAF-15M-0SS0 LM-U2PBD-15M-1SS0 LM-U2PBF-22M-1SS0	TM-RFM004C20 TM-RFM006C20 TM-RFM006E20 TM-RFM012E20 TM-RFM018E20 TM-RFM012G20 TM-RFM040J10

Note. The combination is for increasing the maximum torque of HG-JR53 servo motor to 400%.

(2) With MR-J4W3-B servo amplifier

Servo amplifier	Rotary servo motor		Linear servo motor (primary side)	Direct drive motor
	HG-KR	HG-MR		
MR-J4W3-222B	053 13 23	053 13 23	LM-U2PAB-05M-0SS0 LM-U2PBB-07M-1SS0	TM-RFM002C20
MR-J4W3-444B	053 13 23 43	053 13 23 43	LM-H3P2A-07P-BSS0 LM-H3P3A-12P-CSS0 LM-K2P1A-01M-2SS1 LM-U2PAB-05M-0SS0 LM-U2PAD-10M-0SS0 LM-U2PAF-15M-0SS0 LM-U2PBB-07M-1SS0	TM-RFM002C20 TM-RFM004C20

1. FUNCTIONS AND CONFIGURATION

1.4 Function list

The following table lists the functions of this servo. For details of the functions, refer to the reference field.

Function	Description	Detailed explanation
Position control mode	This servo is used as a position control servo.	
Speed control mode	This servo is used as a speed control servo.	
Torque control mode	This servo is used as a torque control servo.	
High-resolution encoder	High-resolution encoder of 4194304 pulses/rev is used as the encoder of the rotary servo motor compatible with the MELSERVO-J4 series.	
Absolute position detection system	Merely setting a home position once makes home position return unnecessary at every power-on.	Chapter 12
Gain switching function	Using an input device or gain switching conditions (including the servo motor speed) switches gains.	Section 7.2
Advanced vibration suppression control II	This function suppresses vibration at the arm end or residual vibration of the machine.	Section 7.1.5
Adaptive filter II	Servo amplifier detects mechanical resonance and sets filter characteristics automatically to suppress mechanical vibration.	Section 7.1.2
Low-pass filter	Suppresses high-frequency resonance which occurs as servo system response is increased.	Section 7.1.4
Machine analyzer function	Analyzes the frequency characteristic of the mechanical system by simply connecting an MR Configurator2 installed personal computer and servo amplifier. MR Configurator2 is necessary for this function.	
Robust filter	This function provides better disturbance response in case low response level that load to motor inertia ratio is high for such as roll send axes.	[Pr. PE41]
Slight vibration suppression control	Suppresses vibration of ± 1 pulse produced at a servo motor stop.	[Pr. PB24]
Auto tuning	Automatically adjusts the gain to optimum value if load applied to the servo motor shaft varies.	Chapter 6
Regenerative option	Used when the built-in regenerative resistor of the servo amplifier does not have sufficient regenerative capability for the regenerative power generated.	Section 11.2
Alarm history clear	Alarm history is cleared.	[Pr. PC21]
Output signal selection (Device settings)	The pins that output the output devices, including ALM (Malfunction) and DB (Dynamic brake interlock), can be assigned to certain pins of the CN3 connectors.	[Pr. PD07] to [Pr. PD09]
Output signal (DO) forced output	Output signal can be forced on/off independently of the servo status. Use this function for output signal wiring check and others.	Section 4.5.1 (1) (d)
Test operation mode	Jog operation, positioning operation, motor-less operation, DO forced output, and program operation MR Configurator2 is necessary for this function.	Section 4.5
MR Configurator2	Using a personal computer, you can perform the parameter setting, test operation, monitoring, and others.	Section 11.4
Linear servo system	Linear servo system can be configured using a linear servo motor and liner encoder.	Chapter 14
Direct drive servo system	Direct drive servo system can be configured to drive a direct drive motor.	Chapter 15
One-touch adjustment	One click on a certain button on MR Configurator2 adjusts the gains of the servo amplifier. MR Configurator2 is necessary for this function.	Section 6.2
Tough drive function	This function makes the equipment continue operating even under the condition that an alarm occurs. The tough drive function includes two types: the vibration tough drive and the instantaneous power failure tough drive.	Section 7.3
Drive recorder function	This function continuously monitors the servo status and records the status transition before and after an alarm for a fixed period of time. You can check the recorded data on the drive recorder window on MR Configurator2 by clicking the "Graph" button. However, the drive recorder will not operate on the following conditions. 1. You are using the graph function of MR Configurator2. 2. You are using the machine analyzer function. 3. [Pr. PF21] is set to "-1". 4. The controller is not connected (except the test operation mode). 5. An alarm related to the controller is occurring.	[Pr. PA23]

1. FUNCTIONS AND CONFIGURATION

Function	Description	Detailed explanation
STO function	This function is a safety function that complies with IEC/EN 61800-5-2. You can create a safety system for the equipment easily.	Chapter 13
Servo amplifier life diagnosis function	You can check the cumulative energization time and the number of on/off times of the inrush relay. Before the parts of the servo amplifier, including a capacitor and relay, malfunction, this function is useful for finding out the time for their replacement. MR Configurator2 is necessary for this function.	
Power monitoring function	This function calculates the power running and the regenerative power from the data, including the speed and current, in the servo amplifier. For the SSCNET III/H system, MR Configurator2 can display the data, including the power consumption. Since the servo amplifier can send the data to a motion controller, you can analyze the data and display the data on a display.	
Machine diagnostic function	From the data in the servo amplifier, this function estimates the friction and vibrational component of the drive system in the equipment and recognizes an error in the machine parts, including a ball screw and bearing. MR Configurator2 is necessary for this function.	
Fully closed loop system	Fully closed system can be configured using the load-side encoder. (not available with the MR-J4 3-axis servo amplifiers)	Chapter 16

1.5 Model designation

(1) Rating plate

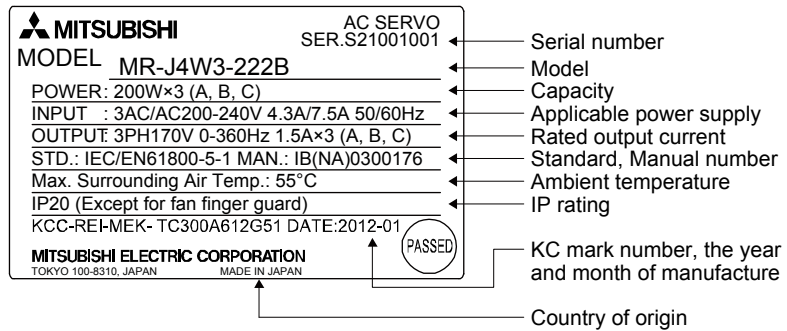

Note. Production year and month of the servo amplifier are indicated in a serial number on the rating plate.

The year and month of manufacture are indicated by the last one digit of the year and 1 to 9, X(10), Y(11), Z(12).

For September 2011, the Serial No. is like, "SERIAL: _ 19 _ _ _ _ _".

(2) Model

The following describes what each block of a model name indicates. Not all combinations of the symbols are available.

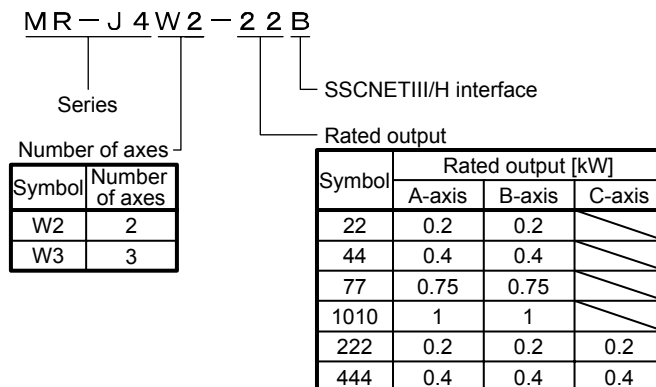

1. FUNCTIONS AND CONFIGURATION

1.6 Parts identification

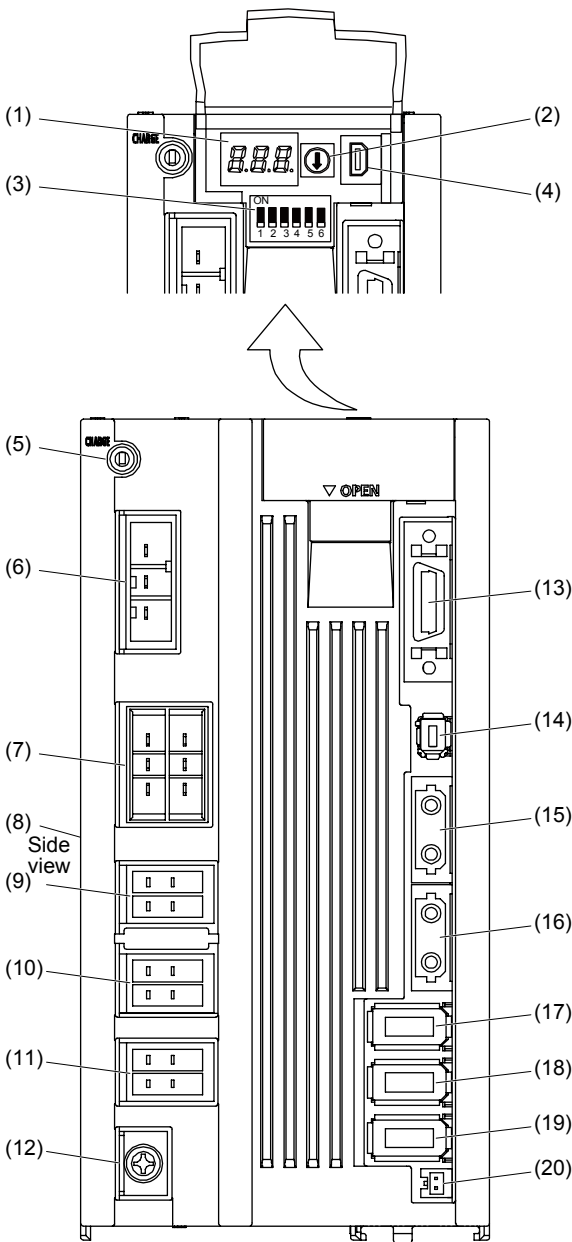

No.	Name/Application	Detailed explanation
(1)	Display The 3-digit, seven-segment LED shows the servo status and the alarm number.	Section 4.3.2
(2)	Axis selection rotary switch (SW1) Used to set the axis No. of servo amplifier.	Section 4.3
(3)	Control axis setting switch (SW2) The test operation switch, the control axis deactivation setting switch, and the auxiliary axis number setting switch are available.	
(4)	USB communication connector (CN5) Connect with the personal computer.	
(5)	Charge lamp Lit to indicate that the main circuit is charged. While this lamp is lit, do not reconnect the cables.	Section 3.1 Section 3.3
(6)	Main circuit power supply connector (CNP1) Connect the input power supply.	
(7)	Control circuit power supply connector (CNP2) Connect the control circuit power supply or regenerative option.	Section 1.5
(8)	Rating plate	Section 3.1 Section 3.3
(9)	A-axis servo motor power supply connector (CNP3A) Connect the A-axis servo motor.	
(10)	B-axis servo motor power supply connector (CNP3B) Connect the B-axis servo motor.	
(11)	C-axis servo motor power supply connector (CNP3C) (Note) Connect the C-axis servo motor.	Section 3.11
(12)	Protective earth (PE) terminal Grounding terminal	Section 3.2 Section 3.4
(13)	I/O signal connector (CN3) Used to connect digital I/O signals.	
(14)	STO input signal connector (CN8) Used to connect MR-J3-D05 safety logic unit and external safety relay.	Chapter 13
(15)	SSCNET III cable connector (CN1A) Used to connect the servo system controller or the previous axis servo amplifier.	Section 3.1 Section 3.3
(16)	SSCNET III cable connector (CN1B) Used to connect the next axis servo amplifier. For the final axis, put a cap.	
(17)	A-axis encoder connector (CN2A) Used to connect the A-axis servo motor encoder.	Section 11.3 Chapter 12
(18)	B-axis encoder connector (CN2B) Used to connect the B-axis servo motor encoder.	
(19)	C-axis encoder connector (CN2C) (Note) Used to connect the C-axis servo motor encoder.	
(20)	Battery connector (CN4) Used to connect the battery unit for absolute position data backup.	

Note. This figure shows the MR-J4 3-axis servo amplifier.

1. FUNCTIONS AND CONFIGURATION

1.7 Configuration including auxiliary equipment

CAUTION ●Connecting a servo motor for different axis to the CNP3A, CNP3B, or CNP3C connector may cause a malfunction.

POINT
●Equipment other than the servo amplifier and servo motor are optional or recommended products.

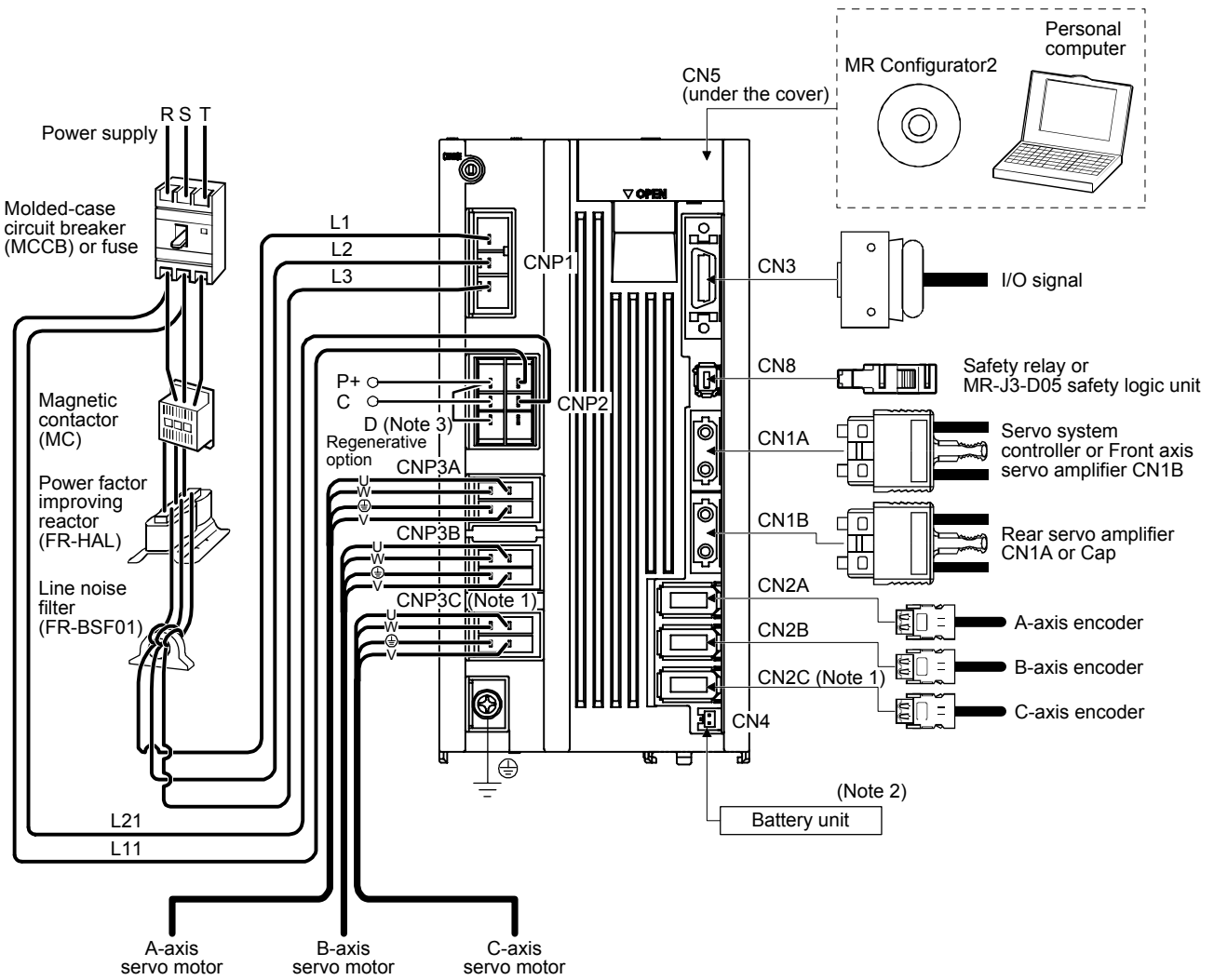

- Note 1. For the MR-J4 3-axis servo amplifier
- Note 2. The battery unit consists of a battery case (MR-BT6VCASE) and up to 5 batteries (MR-BAT6V1). The battery unit is used in the absolute position detection system. (Refer to chapter 12.)
- Note 3. Always connect P+ and D. When using the regenerative option, refer to section 11.2.

2. INSTALLATION

2. INSTALLATION

 **WARNING** ● To prevent electric shock, ground each equipment securely.

 **CAUTION**

- Stacking in excess of the specified number of product packages is not allowed.
- Install the equipment on incombustible material. Installing it directly or close to combustibles will lead to a fire.
- Install the servo amplifier and the servo motor in a load-bearing place in accordance with the Instruction Manual.
- Do not get on or put heavy load on the equipment. Otherwise, it may cause injury.
- Use the equipment within the specified environmental range. For the environment, refer to section 1.3.
- Provide an adequate protection to prevent screws and other conductive matter, oil and other combustible matter from entering the servo amplifier.
- Do not block the intake and exhaust areas of the servo amplifier. Otherwise, it may cause a malfunction.
- Do not drop or strike the servo amplifier. Isolate them from all impact loads.
- Do not install or operate the servo amplifier which have been damaged or have any parts missing.
- When the equipment has been stored for an extended period of time, contact your local sales office.
- When handling the servo amplifier, be careful about the edged parts such as corners of the servo amplifier.
- The servo amplifier must be installed in the metal cabinet.
- When you disinfect or protect wooden packing from insects, take measures except by fumigation. Fumigating the servo amplifier or packing the servo amplifier with fumigated wooden packing can cause a malfunction of the servo amplifier due to halogen materials (such as fluorine, chlorine, bromine, and iodine) which are contained in fumigant.
- The servo amplifier must not be used with parts which contain halogen-series flame retardant materials (such as bromine) under coexisting conditions.

2.1 Installation direction and clearances

 **CAUTION**

- The equipment must be installed in the specified direction. Otherwise, it may cause a malfunction.
- Leave specified clearances between the servo amplifier and the cabinet walls or other equipment. Otherwise, it may cause a malfunction.

When using heat generating equipment such as the regenerative option, install them with full consideration of heat generation so that the servo amplifier is not affected.

Install the servo amplifier on a perpendicular wall in the correct vertical direction.

2. INSTALLATION

(1) Installation of one servo amplifier

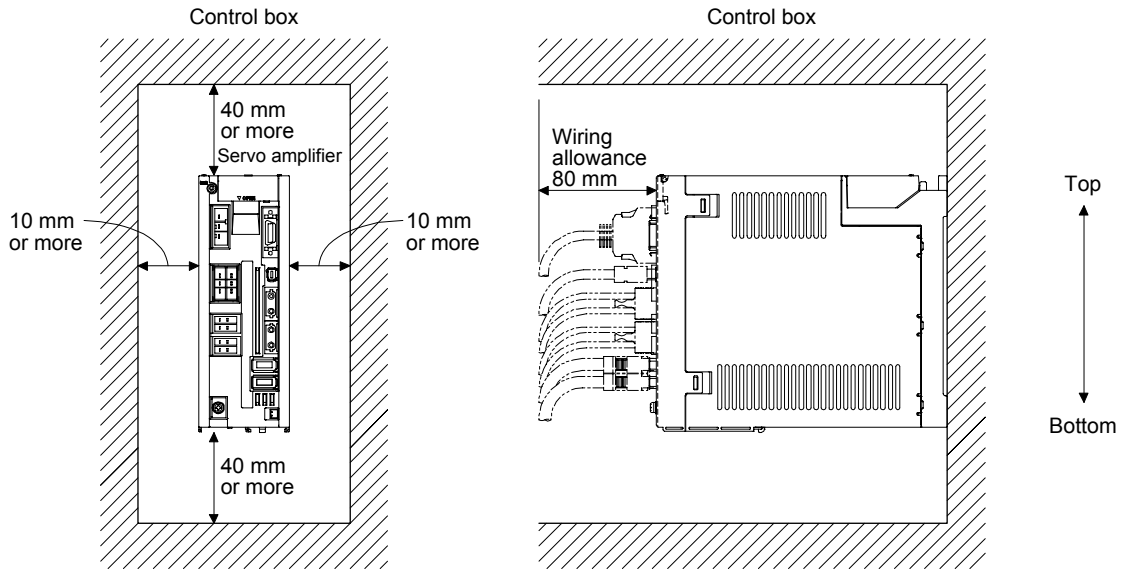

(2) Installation of two or more servo amplifiers

POINT
● You can install MR-J4W_B servo amplifiers without clearances between them.

Leave a large clearance between the top of the servo amplifier and the cabinet walls, and install a cooling fan to prevent the internal temperature of the cabinet from exceeding the environment.

When mounting the servo amplifiers closely, leave a clearance of 1 mm between the adjacent servo amplifiers in consideration of mounting tolerances.

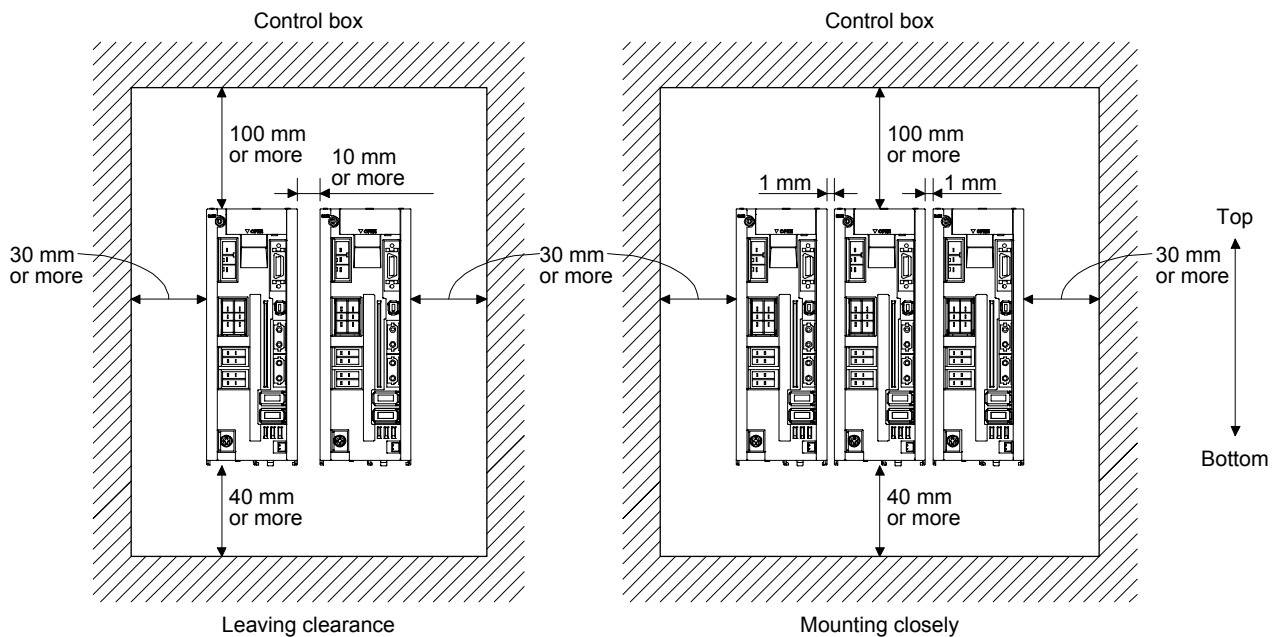

2. INSTALLATION

2.2 Keep out foreign materials

- (1) When drilling in the cabinet, prevent drill chips and wire fragments from entering the servo amplifier.
- (2) Prevent oil, water, metallic dust, etc. from entering the servo amplifier through openings in the cabinet or a cooling fan installed on the ceiling.
- (3) When installing the cabinet in a place where toxic gas, dirt and dust exist, conduct an air purge (force clean air into the cabinet from outside to make the internal pressure higher than the external pressure) to prevent such materials from entering the cabinet.

2.3 Encoder cable stress

- (1) The way of clamping the cable must be fully examined so that bending stress and cable's own weight stress are not applied to the cable connection.
- (2) For use in any application where the servo motor moves, fix the cables (for the encoder, power supply, and brake) with having some slack from the connector connection part of the servo motor to avoid putting stress on the connector connection part. Use the optional encoder cable within the bending life range. Use the power supply and brake wiring cables within the bending life of the cables.
- (3) Avoid any probability that the cable sheath might be cut by sharp chips, rubbed by a machine corner or stamped by workers or vehicles.
- (4) For the cable installation on a machine where the servo motor moves, the bending radius should be made as large as possible. Refer to section 10.4 for the bending life.

2.4 SSCNET III cable laying

SSCNET III cable is made from optical fiber. If optical fiber is added a power such as a major shock, lateral pressure, haul, sudden bending or twist, its inside distorts or breaks, and optical transmission will not be available. Especially, as optical fiber for MR-J3BUS_M/MR-J3BUS_M-A is made of synthetic resin, it melts down if being left near the fire or high temperature. Therefore, do not make it touched the part, which can become hot, such as heat sink or regenerative option of servo amplifier.

Read described item of this section carefully and handle it with caution.

(1) Minimum bend radius

Make sure to lay the cable with greater radius than the minimum bend radius. Do not press the cable to edges of equipment or others. For the SSCNET III cable, the appropriate length should be selected with due consideration for the dimensions and arrangement of the servo amplifier. When closing the door of cabinet, pay careful attention for avoiding the case that SSCNET III cable is held down by the door and the cable bend becomes smaller than the minimum bend radius. For the minimum bend radius, refer to section 11.1.2.

2. INSTALLATION

(2) Prohibition of vinyl tape use

Migrating plasticizer is used for vinyl tape. Keep the MR-J3BUS_M, and MR-J3BUS_M-A cables away from vinyl tape because the optical characteristic may be affected.

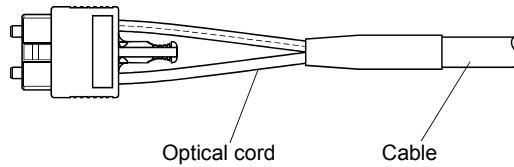

SSCNET III cable	Cord	Cable
MR-J3BUS_M	△	△
MR-J3BUS_M-A	△	△
MR-J3BUS_M-B	○	○

△: Phthalate ester plasticizer such as DBP and DOP may affect optical characteristic of cable.

○: Cord and cable are not affected by plasticizer.

(3) Precautions for migrating plasticizer added materials

Generally, soft polyvinyl chloride (PVC), polyethylene resin (PE) and fluorine resin contain non-migrating plasticizer and they do not affect the optical characteristic of SSCNET III cable. However, some wire sheaths and cable ties, which contain migrating plasticizer (phthalate ester), may affect MR-J3BUS_M and MR-J3BUS_M-A cables.

In addition, MR-J3BUS_M-B cable is not affected by plasticizer.

A chemical substance may affect its optical characteristic. Therefore, previously check that the cable is not affected by the environment.

(4) Bundle fixing

Fix the cable at the closest part to the connector with bundle material in order to prevent SSCNET III cable from putting its own weight on CN1A/CN1B connector of servo amplifier. Optical cord should be given loose slack to avoid from becoming smaller than the minimum bend radius, and it should not be twisted.

When bundling the cable, fix and hold it in position by using cushioning such as sponge or rubber which does not contain migratable plasticizers.

If adhesive tape for bundling the cable is used, fire resistant acetate cloth adhesive tape 570F (Teraoka Seisakusho Co., Ltd) is recommended.

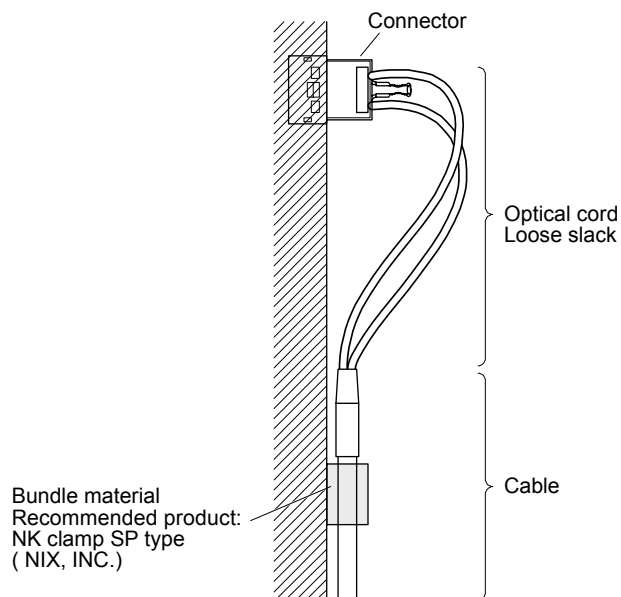

2. INSTALLATION

(5) Tension

If tension is added on optical cable, the increase of transmission loss occurs because of external force which concentrates on the fixing part of optical fiber or the connecting part of optical connector. Doing so may cause the breakage of the optical fiber or damage of the optical connector. For cable laying, handle without putting forced tension. For the tension strength, refer to section 11.1.2.

(6) Lateral pressure

If lateral pressure is added on optical cable, the optical cable itself distorts, internal optical fiber gets stressed, and then transmission loss will increase. Doing so may cause the breakage of the optical cable. As the same condition also occurs at cable laying, do not tighten up optical cable with a thing such as nylon band (TY-RAP).

Do not trample it down or tuck it down with the door of cabinet or others.

(7) Twisting

If optical fiber is twisted, it will become the same stress added condition as when local lateral pressure or bend is added. Consequently, transmission loss increases, and the breakage of optical fiber may occur.

(8) Disposal

When incinerating optical cable (cord) used for SSCNET III, hydrogen fluoride gas or hydrogen chloride gas which is corrosive and harmful may be generated. For disposal of optical fiber, request for specialized industrial waste disposal services who has incineration facility for disposing hydrogen fluoride gas or hydrogen chloride gas.

2.5 Inspection items

 **WARNING**

- Before starting maintenance and/or inspection, turn off the power and wait for 15 minutes or more until the charge lamp turns off. Then, confirm that the voltage between P+ and N- is safe with a voltage tester or others. Otherwise, an electric shock may occur. In addition, when confirming whether the charge lamp is off or not, always confirm it from the front of the servo amplifier.
- To avoid an electric shock, only qualified personnel should attempt inspections. For repair and parts replacement, contact your sales representative.

 **CAUTION**

- Do not perform insulation resistance test on the servo amplifier. Otherwise, it may cause a malfunction.
- Do not disassemble and/or repair the equipment on customer side.

It is recommended to make the following checks periodically.

- (1) Check for loose terminal block screws. Retighten any loose screws.
- (2) Check the cables and wires for scratches and cracks. Inspect them periodically according to operating conditions especially when the servo motor is movable.

2. INSTALLATION

- (3) Check that the connector is securely connected to the servo amplifier.
- (4) Check that the wires are not coming out from the connector.
- (5) Check for dust accumulation on the servo amplifier.
- (6) Check for unusual noise generated from the servo amplifier.

2.6 Parts having service lives

Service lives of the following parts are listed below. However, the service lives vary depending on operating methods and environmental conditions. If any fault is found in the parts, they must be replaced immediately regardless of their service lives.

For parts replacement, please contact your sales representative.

Part name	Life guideline
Smoothing capacitor	10 years
Relay	Number of power-on, forced stop by EM1 (Forced stop 1), and controller forced stop times: 100,000 times Number of on and off for STO: 1,000,000 times
Cooling fan	50,000 hours to 70,000 hours (7 to 8 years)
Absolute position battery	Refer to section 12.2.

(1) Smoothing capacitor

Affected by ripple currents, etc. and deteriorates in characteristic. The life of the capacitor greatly depends on ambient temperature and operating conditions. The capacitor will reach the end of its life in 10 years of continuous operation in normal air-conditioned environment (40 °C surrounding air temperature or less).

(2) Relays

Contact faults will occur due to contact wear arisen from switching currents. Relays reach the end of their lives when the power has been turned on, forced stop by EM1 (Forced stop 1) has occurred, and controller forced stop has occurred 100,000 times in total, or when the STO has been turned on and off 1,000,000 times while the servo motor is stopped under servo-off state. However, the lives of relays may depend on the power supply capacity.

(3) Servo amplifier cooling fan

The cooling fan bearings reach the end of their life in 50,000 hours to 70,000 hours. Normally, therefore, the fan must be changed in seven or eight years of continuous operation as a guideline.

It must also be changed if unusual noise or vibration is found during inspection.

The life is under the environment where a yearly average ambient temperature of 40 °C, free from corrosive gas, flammable gas, oil mist, dust and dirt.

3. SIGNALS AND WIRING

3. SIGNALS AND WIRING

! WARNING

- Any person who is involved in wiring should be fully competent to do the work.
- Before wiring, turn off the power and wait for 15 minutes or more until the charge lamp turns off. Then, confirm that the voltage between P+ and N- is safe with a voltage tester and others. Otherwise, an electric shock may occur. In addition, when confirming whether the charge lamp is off or not, always confirm it from the front of the servo amplifier.
- Ground the servo amplifier and servo motor securely.
- Do not attempt to wire the servo amplifier and servo motor until they have been installed. Otherwise, it may cause an electric shock.
- The cables should not be damaged, stressed, loaded, or pinched. Otherwise, it may cause an electric shock.

● Wire the equipment correctly and securely. Otherwise, the servo motor may operate unexpectedly, resulting in injury.

● Connect cables to the correct terminals. Otherwise, a burst, damage, etc. may occur.

● Ensure that polarity (+/-) is correct. Otherwise, a burst, damage, etc. may occur.

● The surge absorbing diode installed to the DC relay for control output should be fitted in the specified direction. Otherwise, the emergency stop and other protective circuits may not operate.

For sink output interface

For source output interface

! CAUTION

- Use a noise filter, etc. to minimize the influence of electromagnetic interference. Electromagnetic interference may be given to the electronic equipment used near the servo amplifier.
- Do not install a power capacitor, surge killer or radio noise filter (FR-BIF option) with the power line of the servo motor.
- When using the regenerative resistor, switch power off with the alarm signal. Otherwise, a transistor fault or the like may overheat the regenerative resistor, causing a fire.
- Do not modify the equipment.
- Connect the servo amplifier power output (U, V, and W) to the servo motor power input (U, V, and W) directly. Do not let a magnetic contactor, etc. intervene. Otherwise, it may cause a malfunction.

- Connecting a servo motor for different axis to the CNP3A, CNP3B, or CN3C connector may cause a malfunction.

3. SIGNALS AND WIRING

POINT
●When you use a linear servo motor, replace the following left words to the right words. Load to motor inertia ratio → Load to motor mass ratio Torque → thrust (Servo motor) Speed → (Linear servo motor) Speed

3.1 Input power supply circuit

 **CAUTION**

- Always connect a magnetic contactor between the power supply and the main circuit power supply (L1, L2, and L3) of the servo amplifier, in order to configure a circuit that shuts down the power supply on the side of the servo amplifier's power supply. If a magnetic contactor is not connected, continuous flow of a large current may cause a fire when the servo amplifier malfunctions.
- When alarms are occurring in all axes of A, B, and C, shut off the main circuit power supply. Not doing so may cause a fire when a regenerative transistor malfunctions or the like may overheat the regenerative resistor.
- Check the servo amplifier model, and then input proper voltage to the servo amplifier power supply. If input voltage exceeds the upper limit, the servo amplifier will break down.
- The servo amplifier has a built-in surge absorber (varistor) to reduce noise and to suppress lightning surge. The varistor can break down due to its aged deterioration. To prevent a fire, use a molded-case circuit breaker or fuse for input power supply.
- Connecting a servo motor for different axis to the CNP3A, CNP3B, or CN3C connector may cause a malfunction.

POINT
●Even if alarm has occurred, do not switch off the control circuit power supply. When the control circuit power supply has been switched off, optical module does not operate, and optical transmission of SSCNET III/H communication is interrupted. Therefore, the next axis servo amplifier displays "AA" at the indicator and turns into base circuit shut-off. The servo motor stops with starting dynamic brake.
●EM2 has the same device as EM1 in the torque control mode.
●Connect the 1-phase 200 V AC to 240 V AC power supply to L1 and L3. One of the connecting destinations is different from MR-J3W Series Servo Amplifier. When using MR-J4W as a replacement for MR-J3W, be careful not to connect the power to L2.

Configure the wiring so that the main circuit power supply is shut off and the servo-on command turned off after deceleration to a stop due to an alarm occurring, an enabled servo forced stop, or an enabled controller forced stop. A molded-case circuit breaker (MCCB) must be used with the input cables of the main circuit power supply.

3. SIGNALS AND WIRING

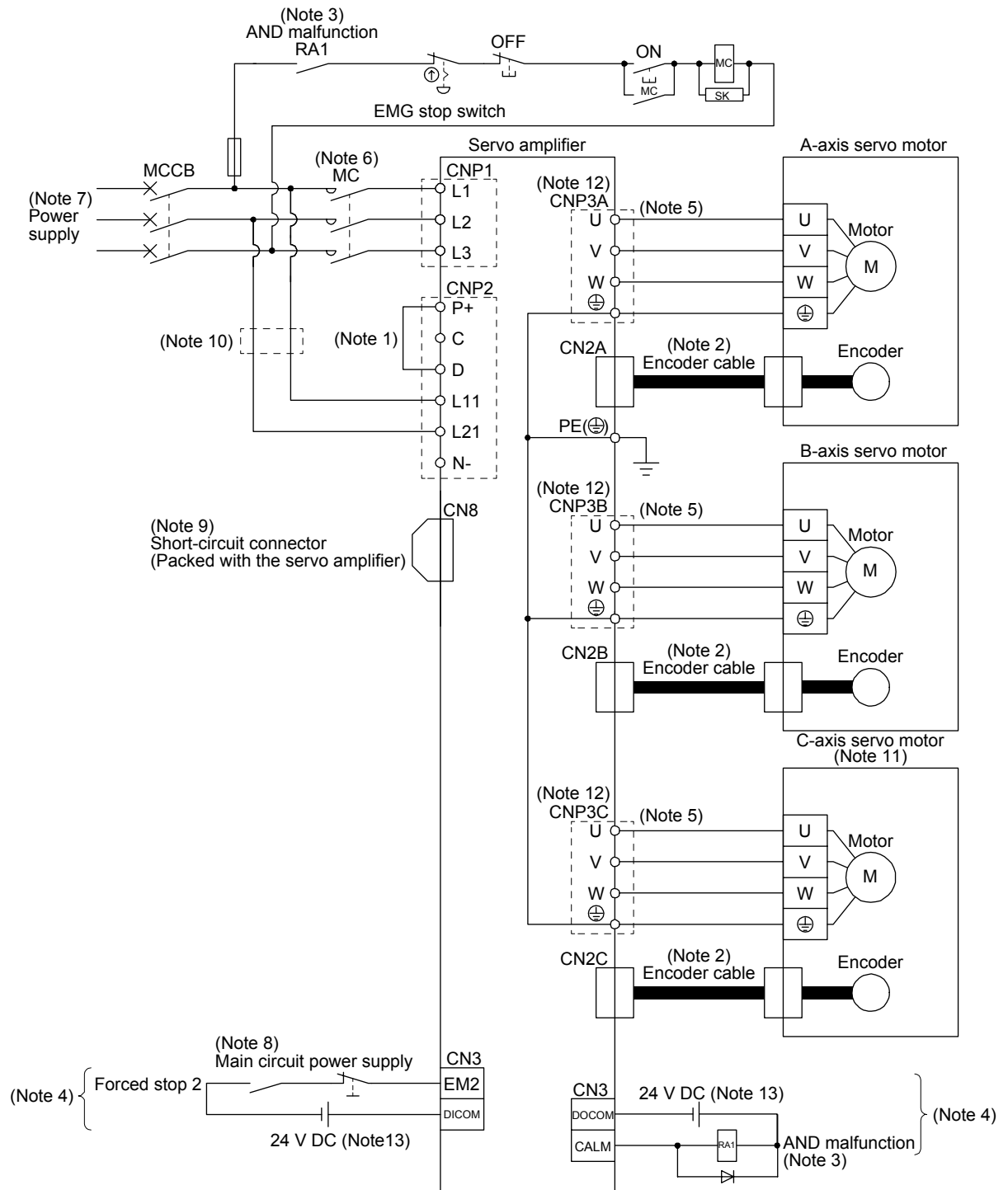

3. SIGNALS AND WIRING

- Note
1. Always connect between P+ and D terminals. (factory-wired) When using the regenerative option, refer to section 11.2.
 2. For the encoder cable, use of the option cable is recommended. For selecting cables, refer to Servo Motor Instruction Manual (Vol. 3).
 3. This circuit is an example of stopping all axes when an alarm occurs. If disabling CALM (AND malfunction) output with the parameter, configure up the power supply circuit which switches off the magnetic contactor after detection of alarm occurrence on the controller side.
 4. This diagram is for sink I/O interface. For source I/O interface, refer to section 3.8.3.
 5. For connecting servo motor power wires, refer to Servo Motor Instruction Manual (Vol. 3).
 6. Use a magnetic contactor with an operation delay time (interval between current being applied to the coil until closure of contacts) of 80 ms or less. Depending on the main circuit voltage and operation pattern, bus voltage decreases, and that may cause the forced stop deceleration to shift to the dynamic brake deceleration. When dynamic brake deceleration is not required, slow the time to turn off the magnetic contactor.
 7. For 1-phase 200 V AC to 240 V AC, connect the power supply to L1 and L3. Leave L2 open. For power supply specifications, refer to section 1.3.
 8. Configure up a circuit to turn off EM2 when the main circuit power is turned off to prevent an unexpected restart of the servo amplifier.
 9. When not using the STO function, attach a short-circuit connector supplied with a servo amplifier.
 10. When wires used for L11 and L21 are thinner than wires used for L1, L2, and L3, use a molded-case circuit breaker. (Refer to section 11.10.)
 11. For the MR-J4 3-axis servo amplifier
 12. Connecting a servo motor for different axis to the CNP3A, CNP3B, or CN3C connector may cause a malfunction.
 13. The illustration of the 24 V DC power supply is divided between input signal and output signal for convenience. However, they can be configured by one.

3. SIGNALS AND WIRING

3.2 I/O signal connection example

POINT
●EM2 has the same device as EM1 in the torque control mode.

3.2.1 For sink I/O interface

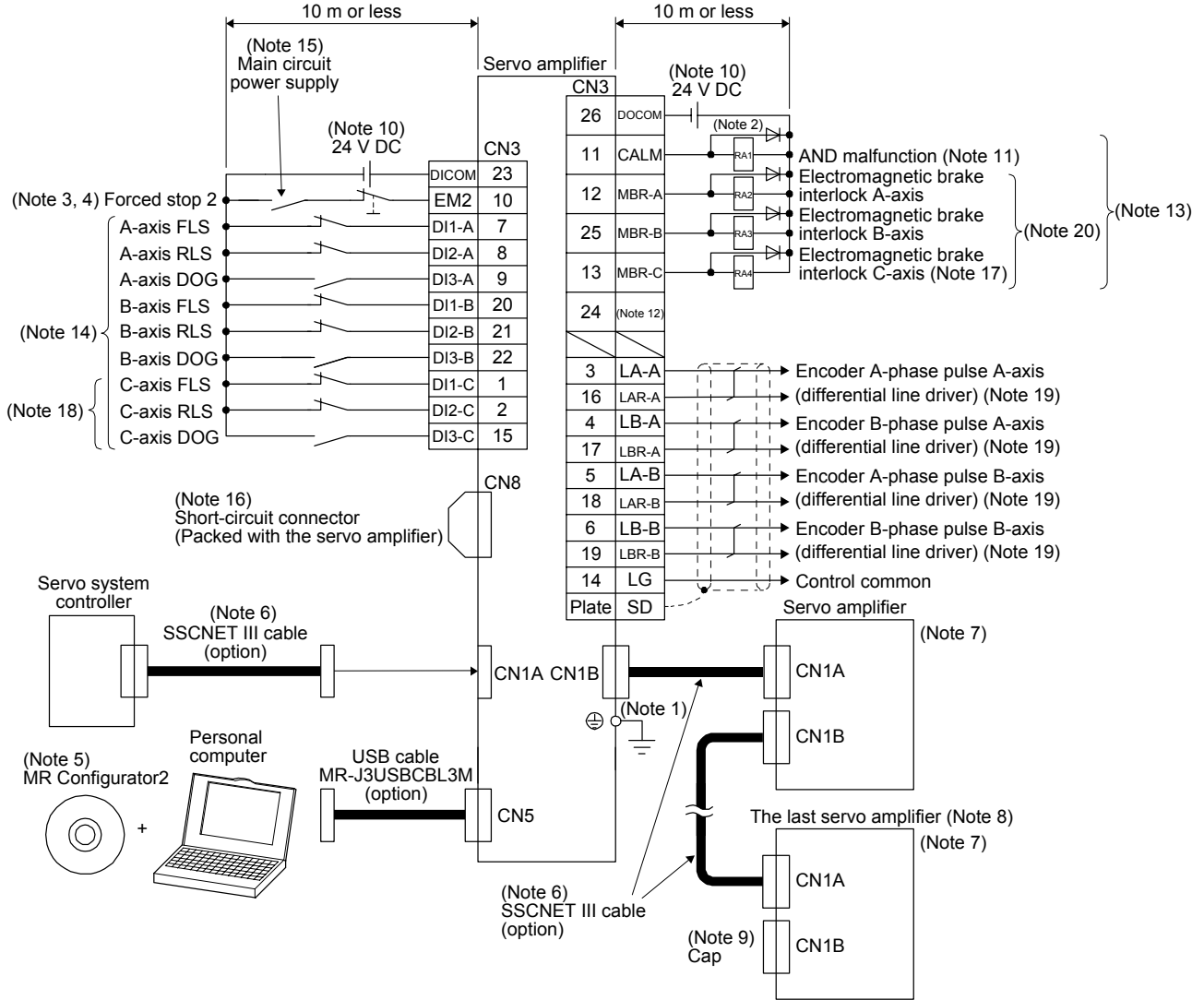

3. SIGNALS AND WIRING

- Note
1. To prevent an electric shock, always connect the protective earth (PE) terminal (marked ⊕) of the servo amplifier to the protective earth (PE) of the cabinet.
 2. Connect the diode in the correct direction. If it is connected reversely, the servo amplifier will malfunction and will not output signals, disabling EM2 (Forced stop 2) and other protective circuits.
 3. If the controller does not have forced stop function, always install the forced stop 2 switch (Normally closed contact).
 4. When starting operation, always turn on EM2 (Forced stop 2). (Normally closed contact)
 5. Use SW1DNC-MRC2-E. (Refer to section 11.4.)
 6. Use SSCNET III cables listed in the following table.

Cable	Cable model	Cable length
Standard cord inside panel	MR-J3BUS_M	0.15 m to 3 m
Standard cable outside panel	MR-J3BUS_M-A	5 m to 20 m
Long-distance cable	MR-J3BUS_M-B	30 m to 50 m

7. The wiring after the second servo amplifier is omitted.
8. Up to 64 axes of servo amplifiers can be connected. The number of connectable axes depends on the controller you use. Refer to section 4.6 for setting of axis selection.
9. Make sure to cap the unused CN1B connector.
10. Supply 24 V DC ± 10% for interfaces from outside. Set the total current capacity to 350 mA for MR-J4W2-_B and to 450 mA for MR-J4W3-_B. The 24 V DC power supply can be used both for input signals and output signals. 350 mA and 450 mA are the values applicable when all I/O signals are used. The current capacity can be decreased by reducing the number of I/O points. Refer to section 3.8.2 (1) that gives the current value necessary for the interface. The illustration of the 24 V DC power supply is divided between input signal and output signal for convenience. However, they can be configured by one.
11. CALM (AND malfunction) turns on in normal alarm-free condition. (Normally closed contact)
12. In the initial setting, CINP (AND in-position) is assigned to the pin. You can change devices of the pin with [Pr. PD07], [Pr. PD08], and [Pr. PD09].
13. You can change devices of these pins with [Pr. PD07], [Pr. PD08], and [Pr. PD09].
14. Devices can be assigned for these devices with controller setting. For devices that can be assigned, refer to the controller instruction manual. The following devices can be assigned for Q172DSCPU, Q173DSCPU, and OD77MS_.
15. Configure up a circuit to turn off EM2 when the main circuit power is turned off to prevent an unexpected restart of the servo amplifier.
16. When not using the STO function, attach a short-circuit connector supplied with a servo amplifier.
17. The pin is not used for MR-J4 2-axis servo amplifiers.
18. For the MR-J4 3-axis servo amplifier
19. This signal cannot be used for MR-J4W3-_B.
20. When you use a linear servo motor or direct drive motor, use MBR (Electromagnetic brake interlock) for an external brake mechanism.

3. SIGNALS AND WIRING

3.2.2 For source I/O interface

POINT

● For notes, refer to section 3.2.1.

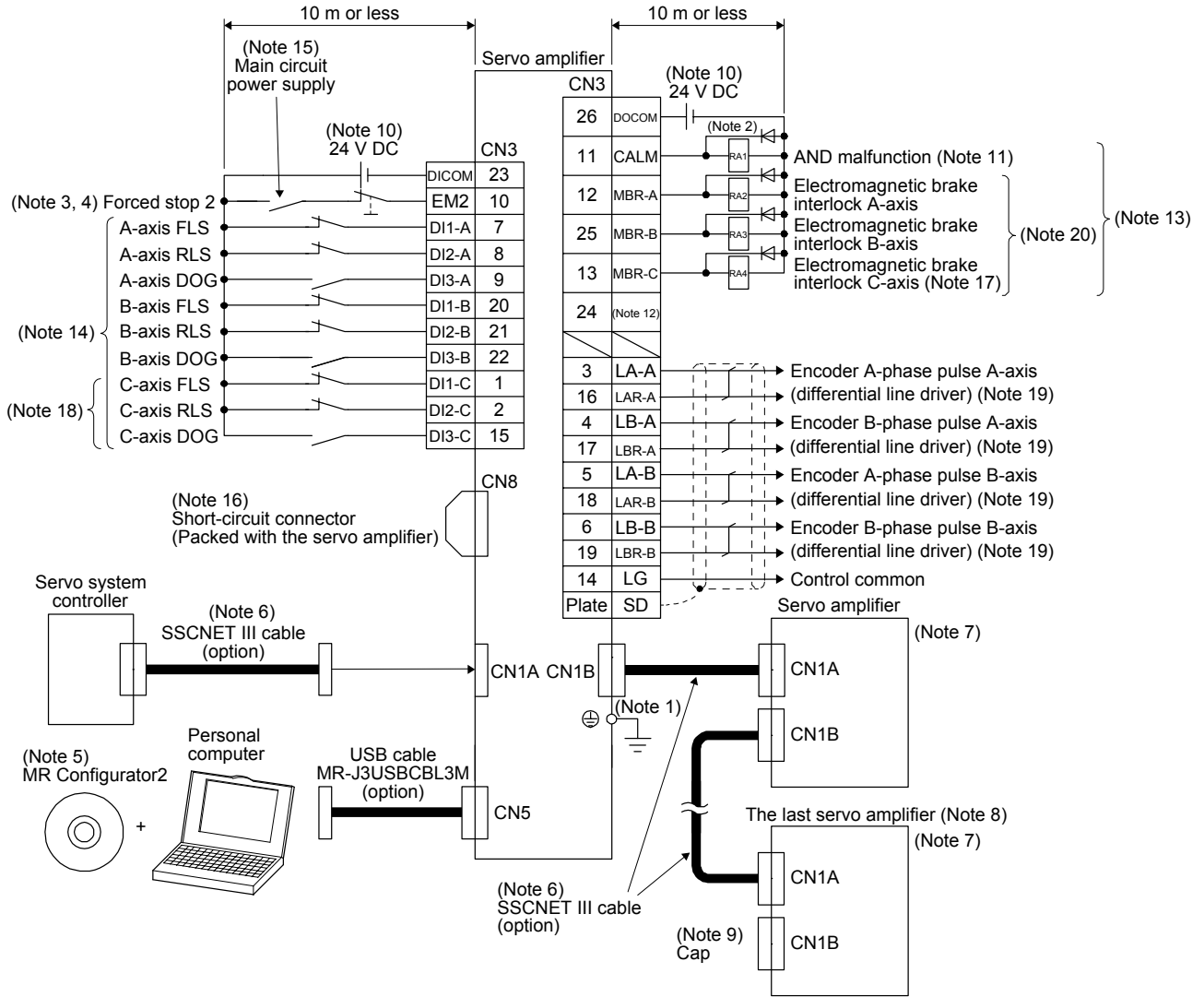

3. SIGNALS AND WIRING

3.3 Explanation of power supply system

3.3.1 Signal explanations

POINT

● N- terminal is for manufacturer. Be sure to leave this terminal open.

(1) Pin assignment and connector applications

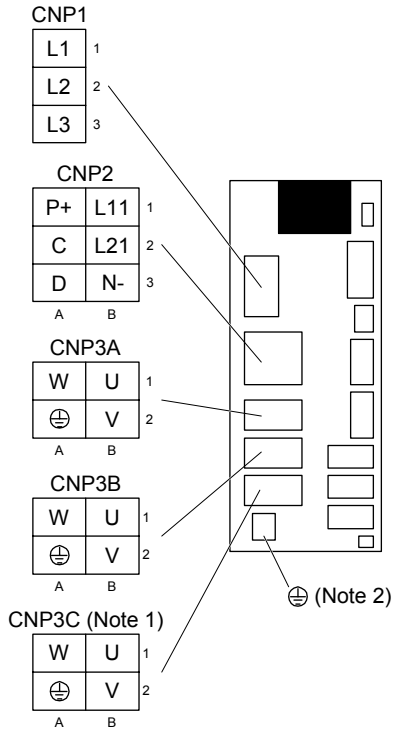

Connector	Name	Function and application
CNP1	Main circuit power supply connector	Input main circuit power supply.
CNP2	Control circuit power supply connector	Input control circuit power supply. Connect regenerative option.
CNP3A	A-axis servo motor power supply connector	Connect with the A-axis servo motor.
CNP3B	B-axis servo motor power supply connector	Connect with the B-axis servo motor.
CNP3C (Note 1)	C-axis servo motor power supply connector	Connect with the C-axis servo motor.

- Note 1. For the MR-J4 3-axis servo amplifier
 2. Connect to the protective earth (PE) of the cabinet to ground.

3. SIGNALS AND WIRING

(2) Detailed explanation

Symbol	Connector	Connection destination (application)	Description															
L1/L2/L3	CNP1	Main circuit power supply	<p>Supply the following power to L1, L2, and L3. For 1-phase 200 V AC to 240 V AC, connect the power supply to L1 and L3. Leave L2 open.</p> <table border="1"> <tr> <td rowspan="2">Power supply</td> <td>Servo amplifier</td> <td>MR-J4W2-22B MR-J4W2-44B MR-J4W2-77B MR-J4W3-222B MR-J4W3-444B</td> <td>MR-J4W2-1010B</td> </tr> <tr> <td></td> <td></td> <td></td> </tr> <tr> <td colspan="2">3-phase 200 V AC to 240 V AC, 50 Hz/60 Hz</td> <td colspan="2">L1/L2/L3</td> </tr> <tr> <td colspan="2">1-phase 200 V AC to 240 V AC, 50 Hz/60 Hz</td> <td>L1/L3</td> <td></td> </tr> </table>	Power supply	Servo amplifier	MR-J4W2-22B MR-J4W2-44B MR-J4W2-77B MR-J4W3-222B MR-J4W3-444B	MR-J4W2-1010B				3-phase 200 V AC to 240 V AC, 50 Hz/60 Hz		L1/L2/L3		1-phase 200 V AC to 240 V AC, 50 Hz/60 Hz		L1/L3	
Power supply	Servo amplifier	MR-J4W2-22B MR-J4W2-44B MR-J4W2-77B MR-J4W3-222B MR-J4W3-444B	MR-J4W2-1010B															
3-phase 200 V AC to 240 V AC, 50 Hz/60 Hz		L1/L2/L3																
1-phase 200 V AC to 240 V AC, 50 Hz/60 Hz		L1/L3																
P+/C/D	CNP2	Regenerative option	When using a servo amplifier built-in regenerative resistor, connect P+ and D. (factory-wired) When using a regenerative option, connect the regenerative option to P+ and C. Refer to section 11.2 for details.															
N-		For manufacturer	N- terminal is for manufacturer. Be sure to leave this terminal open.															
L11/L21		Control circuit power supply	<p>Supply the following power to L11 and L21.</p> <table border="1"> <tr> <td rowspan="2">Power supply</td> <td>Servo amplifier</td> <td>MR-J4W2-22B to MR-J4W2-1010B MR-J4W3-222B to MR-J4W3-444B</td> </tr> <tr> <td></td> <td></td> </tr> <tr> <td colspan="2">1-phase 200 V AC to 240 V AC</td> <td>L11/L21</td> </tr> </table>	Power supply	Servo amplifier	MR-J4W2-22B to MR-J4W2-1010B MR-J4W3-222B to MR-J4W3-444B			1-phase 200 V AC to 240 V AC		L11/L21							
Power supply	Servo amplifier	MR-J4W2-22B to MR-J4W2-1010B MR-J4W3-222B to MR-J4W3-444B																
1-phase 200 V AC to 240 V AC		L11/L21																
U/V/W	CNP3A CNP3B CNP3C	Servo motor power output	Connect them to the servo motor power supply (U, V, and W). Connect the servo amplifier power output (U, V, and W) to the servo motor power input (U, V, and W) directly. Do not let a magnetic contactor, etc. intervene. Otherwise, it may cause a malfunction.															
⊕ (Note 2)	(Note 1)	Protective earth (PE)	Connect the grounding terminal of the servo motor.															
⊕ (Note 2)		Protective earth (PE)	Connect to the protective earth (PE) of the cabinet to ground.															

Note 1. For the MR-J4 3-axis servo amplifier

2. Connect the grounding terminal of the servo motor to ⊕ of CNP3A, CNP3B, and CNP3C. For grounding, connect the protective earth (PE) terminal (⊕) of front lower part on the servo amplifier to the protective earth (PE) terminal on a cabinet.

3. SIGNALS AND WIRING

3.3.2 Power-on sequence

POINT
<p>● A voltage, output signal, etc. of analog monitor output may be irregular at power-on.</p>

(1) Power-on procedure

- 1) Always wire the power supply as shown in above section 3.1 using the magnetic contactor with the main circuit power supply (3-phase: L1, L2, and L3, 1-phase: L1 and L3). Configure up an external sequence to switch off the magnetic contactor as soon as an alarm occurs in all axes of A, B, and C.
- 2) Switch on the control circuit power supply (L11 and L21) simultaneously with the main circuit power supply or before switching on the main circuit power supply. If the control circuit power supply is turned on with the main circuit power supply off, and then the servo-on command is transmitted, [AL. E9 Main circuit off warning] will occur. Turning on the main circuit power supply stops the warning and starts the normal operation.
- 3) The servo amplifier receives the servo-on command within 4 s after the main circuit power supply is switched on.
(Refer to (2) of this section.)

(2) Timing chart

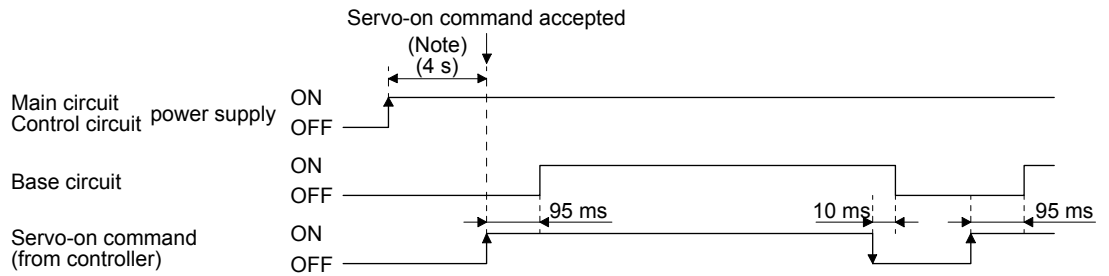

Note. The time will be longer during the magnetic pole detection of a linear servo motor and direct drive motor.

3. SIGNALS AND WIRING

3.3.3 Wiring CNP1, CNP2, and CNP3

(1) Connector

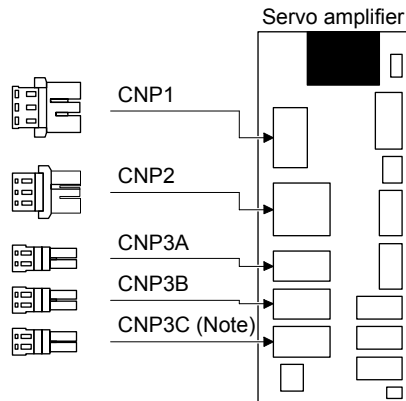

Note. For the MR-J4 3-axis servo amplifier

Table 3.1 Connector and applicable wire

Connector	Receptacle assembly	Applicable wire size	Stripped length [mm]	Open tool	Manufacturer
CNP1	03JFAT-SAXGFK-43	AWG 16 to 14	11.5	J-FAT-OT-EXL (big size side)	JST
CNP2	06JFAT-SAXYGG-F-KK	AWG 16 to 14	9	J-FAT-OT-EXL (small size side)	
CNP3A CNP3B CNP3C	04JFAT-SAGG-G-KK	AWG 18 to 14	9	J-FAT-OT-EXL (small size side)	

(2) Cable connection procedure

(a) Cable making

Refer to table 3.1 for stripped length of cable insulator. The appropriate stripped length of cables depends on their type, etc. Set the length considering their status.

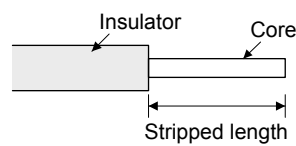

Twist strands slightly and straighten them as follows.

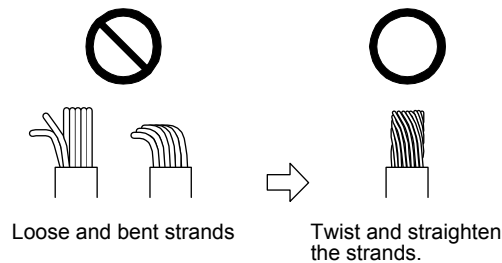

3. SIGNALS AND WIRING

You can also use a ferrule to connect with the connectors. The following shows references to select ferrules according to wire sizes.

Wire size	Ferrule model (Phenix contact)		Crimping tool (Phenix contact)
	For 1 wire	For 2 wires	
AWG16	AI1.5-10BK	AI-TWIN2×1.5-10BK	CRIMPFOX-ZA3
AWG14	AI2.5-10BU		

(b) Inserting wire

Insert the open tool as follows and push down it to open the spring. While the open tool is pushed down, insert the stripped wire into the wire insertion hole. Check the insertion depth so that the cable insulator does not get caught by the spring.

Release the open tool to fix the wire. Pull the wire lightly to confirm that the wire is surely connected. The following shows a connection example of the CNP1 connector.

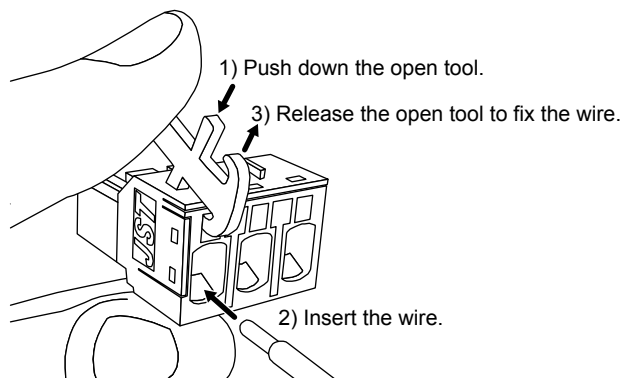

3. SIGNALS AND WIRING

3.4 Connectors and pin assignment

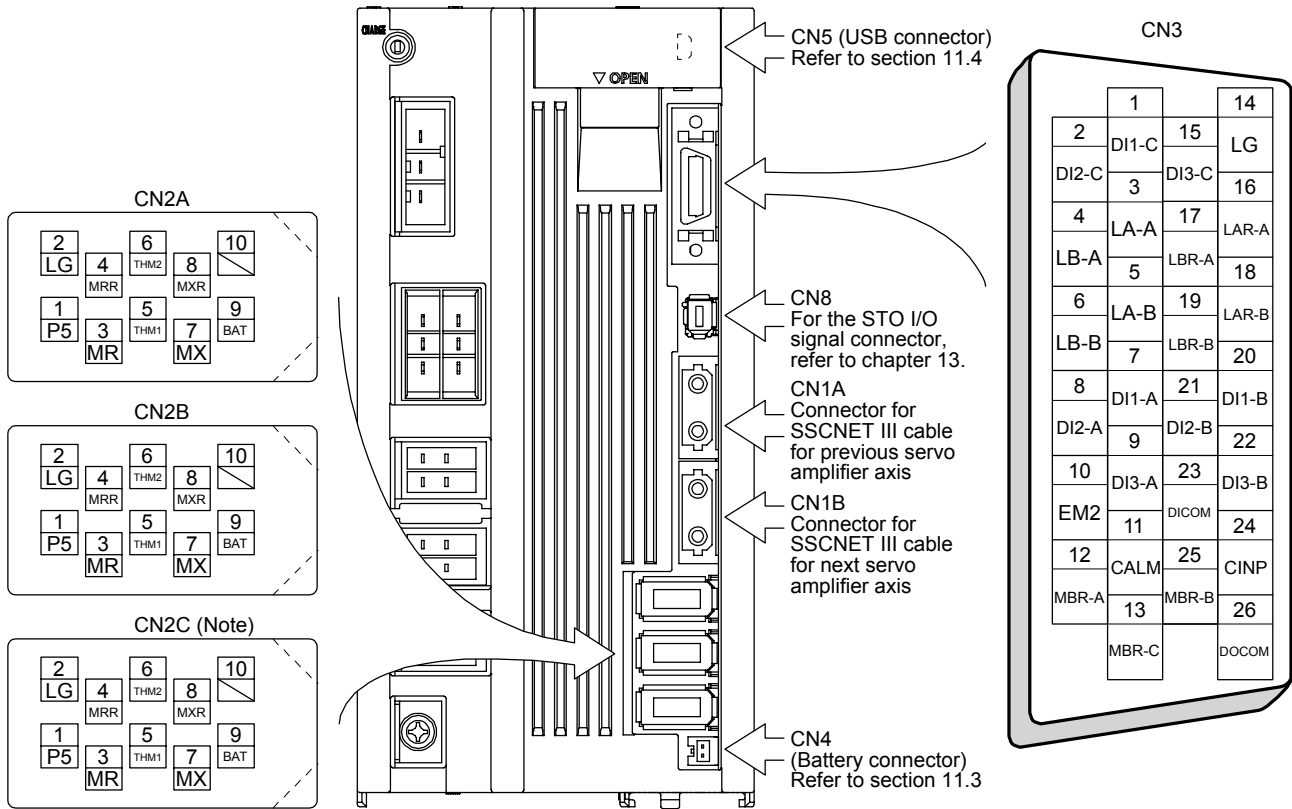
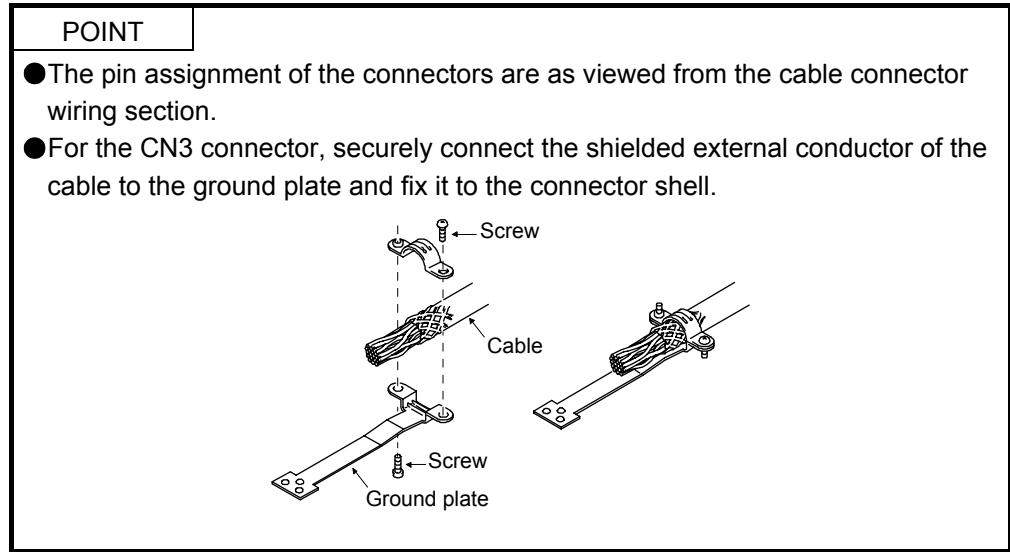

The 3M make connector is shown.

The frames of the CN2A, CN2B, CN2C and CN3 connectors are connected to the protective earth terminal in the servo amplifier.

Note. For the MR-J4 3-axis servo amplifier

3. SIGNALS AND WIRING

3.5 Signal (device) explanations

For the I/O interfaces (symbols in I/O division column in the table), refer to section 3.8.

The pin numbers in the connector pin No. column are those in the initial status.

3.5.1 Input device

Device	Symbol	Connector pin No.	Function and application	I/O division																						
Forced stop 2	EM2	(CN3-10)	<p>Turn off EM2 (open between commons) to decelerate the servo motor to a stop with commands.</p> <p>Turn EM2 on (short between commons) in the forced stop state to reset that state.</p> <p>Set [Pr. PA04] to "2 1 __" to disable EM2.</p> <p>The following shows the setting of [Pr. PA04].</p> <table border="1"> <thead> <tr> <th rowspan="2">[Pr. PA04] setting</th> <th rowspan="2">EM2/EM1</th> <th colspan="2">Deceleration method</th> </tr> <tr> <th>EM2 or EM1 is off</th> <th>Alarm occurred</th> </tr> </thead> <tbody> <tr> <td>0 0 __</td> <td>EM1</td> <td>MBR (Electromagnetic brake interlock) turns off without the forced stop deceleration.</td> <td>MBR (Electromagnetic brake interlock) turns off without the forced stop deceleration.</td> </tr> <tr> <td>2 0 __</td> <td>EM2</td> <td>MBR (Electromagnetic brake interlock) turns off after the forced stop deceleration.</td> <td>MBR (Electromagnetic brake interlock) turns off after the forced stop deceleration.</td> </tr> <tr> <td>0 1 __</td> <td>Not using EM2 or EM1</td> <td style="text-align: center;">/</td> <td>MBR (Electromagnetic brake interlock) turns off without the forced stop deceleration.</td> </tr> <tr> <td>2 1 __</td> <td>Not using EM2 or EM1</td> <td style="text-align: center;">/</td> <td>MBR (Electromagnetic brake interlock) turns off after the forced stop deceleration.</td> </tr> </tbody> </table>	[Pr. PA04] setting	EM2/EM1	Deceleration method		EM2 or EM1 is off	Alarm occurred	0 0 __	EM1	MBR (Electromagnetic brake interlock) turns off without the forced stop deceleration.	MBR (Electromagnetic brake interlock) turns off without the forced stop deceleration.	2 0 __	EM2	MBR (Electromagnetic brake interlock) turns off after the forced stop deceleration.	MBR (Electromagnetic brake interlock) turns off after the forced stop deceleration.	0 1 __	Not using EM2 or EM1	/	MBR (Electromagnetic brake interlock) turns off without the forced stop deceleration.	2 1 __	Not using EM2 or EM1	/	MBR (Electromagnetic brake interlock) turns off after the forced stop deceleration.	DI-1
			[Pr. PA04] setting			EM2/EM1	Deceleration method																			
				EM2 or EM1 is off	Alarm occurred																					
			0 0 __	EM1	MBR (Electromagnetic brake interlock) turns off without the forced stop deceleration.	MBR (Electromagnetic brake interlock) turns off without the forced stop deceleration.																				
			2 0 __	EM2	MBR (Electromagnetic brake interlock) turns off after the forced stop deceleration.	MBR (Electromagnetic brake interlock) turns off after the forced stop deceleration.																				
0 1 __	Not using EM2 or EM1	/	MBR (Electromagnetic brake interlock) turns off without the forced stop deceleration.																							
2 1 __	Not using EM2 or EM1	/	MBR (Electromagnetic brake interlock) turns off after the forced stop deceleration.																							
EM2 and EM1 are mutually exclusive.																										
EM2 has the same device as EM1 in the torque control mode.																										
Forced stop 1	EM1	(CN3-10)	<p>When using EM1, set [Pr. PA04] to "0 0 __" to enable EM1.</p> <p>Turn EM1 off (open between commons) to bring the motor to an forced stop state. The base circuit is shut off, the dynamic brake is operated and decelerate the servo motor to a stop.</p> <p>Turn EM1 on (short between commons) in the forced stop state to reset that state.</p> <p>Set [Pr. PA04] to "0 1 __" to disable EM1.</p>	DI-1																						
/	DI1-A	CN3-7	<p>Devices can be assigned for these devices with controller setting. For devices that can be assigned, refer to the controller instruction manual. You can assign the following devices with MR-J4 series compatible controllers (Q172DSCPU, Q173DSCPU, and QD77MS_)</p> <p>DI1-A: FLS for A-axis (Upper stroke limit)</p> <p>DI2-A: RLS for A-axis (Lower stroke limit)</p> <p>DI3-A: DOG for A-axis (Proximity dog)</p> <p>DI1-B: FLS for B-axis (Upper stroke limit)</p> <p>DI2-B: RLS for B-axis (Lower stroke limit)</p> <p>DI3-B: DOG for B-axis (Proximity dog)</p> <p>DI1-C: FLS for C-axis (Upper stroke limit)</p> <p>DI2-C: RLS for C-axis (Lower stroke limit)</p> <p>DI3-C: DOG for C-axis (Proximity dog)</p>	DI-1																						
	DI2-A	CN3-8		DI-1																						
	DI3-A	CN3-9		DI-1																						
	DI1-B	CN3-20		DI-1																						
	DI2-B	CN3-21		DI-1																						
	DI3-B	CN3-22		DI-1																						
	DI1-C	CN3-1		DI-1																						
	DI2-C	CN3-2		DI-1																						
	DI3-C	CN3-15		DI-1																						

3. SIGNALS AND WIRING

3.5.2 Output device

(1) Output device pin

The following shows the output device pins and parameters for assigning devices.

Connector pin No.	Parameter			Initial device	I/O division	Remarks
	A-axis	B-axis	C-axis			
CN3-12	[Pr. PD07]			MBR-A	DO-1	For A-axis
CN3-25		[Pr. PD07]		MBR-B		For B-axis
CN3-13			[Pr. PD07]	MBR-C		For C-axis (Note)
CN3-11	[Pr. PD09]	[Pr. PD09]	[Pr. PD09]	CALM		Common pin
CN3-24	[Pr. PD08]	[Pr. PD08]	[Pr. PD08]	CINP		Common pin

Note. The pin is not used for MR-J4 2-axis servo amplifiers.

(2) Output device explanations

POINT		
<p>● Initial letter and last letter with hyphen in device symbols mean target axis. Refer to the following table.</p>		
Symbol (Note)	Target axis	Description
C _ _ _	A/B/C	When all axes of A, B, and C meet a condition, the device will be enabled (on or off).
X _ _ _	A/B/C	When each axis of A, B, or C meet a condition, the device will be enabled (on or off).
_ _ _ -A	A-axis	Device for A-axis
_ _ _ -B	B-axis	Device for B-axis
_ _ _ -C	C-axis	Device for C-axis
<p>Note. _ _ _ differs depending on devices.</p>		

Device	Symbol	Function and application
AND electromagnetic brake interlock	CMBR	When using the device, set operation delay time of the electromagnetic brake in [Pr. PC02]. When a servo-off status or alarm occurs, MBR will turn off.
OR electromagnetic brake interlock	XMBR	
Electromagnetic brake interlock for A-axis	MBR-A	
Electromagnetic brake interlock for B-axis	MBR-B	
Electromagnetic brake interlock for C-axis	MBR-C	
AND malfunction	CALM	When the protective circuit is activated to shut off the base circuit, ALM will turn off. When an alarm does not occur, ALM will turn on about 3 s after power-on.
OR malfunction	XALM	
Malfunction for A-axis	ALM-A	
Malfunction for B-axis	ALM-B	
Malfunction for C-axis	ALM-C	
AND in-position	CINP	When the number of droop pulses is in the preset in-position range, INP will turn on. The in-position range can be changed using [Pr. PA10]. When the in-position range is increased, INP may be on during low-speed rotation. The device cannot be used in the speed control mode, torque control mode, and for continuous operation to torque control mode.
OR in-position	XINP	
In-position for A-axis	INP-A	
In-position for B-axis	INP-B	
In-position for C-axis	INP-C	

3. SIGNALS AND WIRING

Device	Symbol	Function and application
AND ready	CRD	Enabling servo-on to make the servo amplifier ready to operate will turn on RD.
OR ready	XRD	
Common ready for A-axis	RD-A	
Common ready for B-axis	RD-B	
Common ready for C-axis	RD-C	
AND speed reached	CSA	SA will turn off during servo-off. When the servo motor speed reaches the following range, SA will turn on. Set speed $\pm ((\text{Set speed} \times 0.05) + 20)$ r/min When the preset speed is 20 r/min or less, SA always turns on. The device cannot be used in the position control mode and torque control mode.
OR speed reached	XSA	
Speed reached for A-axis	SA-A	
Speed reached for B-axis	SA-B	
Speed reached for C-axis	SA-C	
AND limiting speed	CVLC	
OR limiting speed	XVLC	
Limiting speed for A-axis	VLC-A	
Limiting speed for B-axis	VLC-B	
Limiting speed for C-axis	VLC-C	
AND zero speed detection	CZSP	ZSP turns on when the servo motor speed is zero speed (50r/min) or less. Zero speed can be changed with [Pr. PC07].
OR zero speed detection	XZSP	
Zero speed detection for A-axis	ZSP-A	
Zero speed detection for B-axis	ZSP-B	
Zero speed detection for C-axis	ZSP-C	
		<p>The graph illustrates the Zero Speed Detection (ZSP) signal's behavior based on servo motor speed. The vertical axis represents speed in r/min, with 0 r/min at the center. Forward rotation is positive, and reverse rotation is negative. The ZSP signal is ON (high) when the speed is between 50 r/min and -50 r/min, and OFF (low) otherwise. The hysteresis width is 20 r/min. Key points on the speed curve are labeled: 1 (deceleration to 50 r/min), 2 (acceleration to 70 r/min), 3 (deceleration to -50 r/min), and 4 (acceleration to -70 r/min).</p>
		<p>ZSP will turn on when the servo motor is decelerated to 50 r/min (at 1)), and will turn off when the servo motor is accelerated to 70 r/min again (at 2)).</p> <p>ZSP will turn on when the servo motor is decelerated again to 50 r/min (at 3)), and will turn off when the servo motor speed has reached -70 r/min (at 4)).</p> <p>The range from the point when the servo motor speed has reached on level, and ZSP turns on, to the point when it is accelerated again and has reached off level is called hysteresis width. Hysteresis width is 20 r/min for this servo amplifier.</p> <p>When you use a linear servo motor, [r/min] explained above will be [mm/s].</p>
AND limiting torque	CTL	When the torque reaches the torque limit value during torque generation, TLC will turn on. When the servo is off, TLC will be turned off. This device cannot be used in the torque control mode.
OR limiting torque	XTLC	
Limiting torque for A-axis	TLC-A	
Limiting torque for B-axis	TLC-B	
Limiting torque for C-axis	TLC-C	

3. SIGNALS AND WIRING

Device	Symbol	Function and application
AND wrning	CWNG	When warning has occurred, WNG turns on. When a warning is not occurring, turning on the power will turn off WNG after about 3 s.
OR warning	XWNG	
Warning for A-axis	WNG-A	
Warning for B-axis	WNG-B	
Warning for C-axis	WNG-C	
AND battery warning	CBWNG	BWNG turns on when [AL. 92 Battery cable disconnection warning] or [AL. 9F Battery warning] has occurred. When the battery warning is not occurring, BWNG will turn off about 3 s after power-on.
OR battery warning	XBWNG	
Battery warning for A-axis	BWNG-A	
Battery warning for B-axis	BWNG-B	
Battery warning for C-axis	BWNG-C	
AND variable gain selection	CCDPS	CDPS will turn on during variable gain.
OR variable gain selection	XCDPS	
Variable gain selection for A-axis	CDPS-A	
Variable gain selection for B-axis	CDPS-B	
Variable gain selection for C-axis	CDPS-C	
AND absolute position undetermined	CABSV	ABSV turns on when the absolute position is undetermined. The device cannot be used in the speed control mode and torque control mode.
OR absolute position undetermined	XABSV	
Absolute position undetermined for A-axis	ABSV-A	
Absolute position undetermined for B-axis	ABSV-B	
Absolute position undetermined for C-axis	ABSV-C	
AND during tough drive	CMTTR	When a tough drive is enabled in [Pr. PA20], activating the instantaneous power failure tough drive will turn on MTTR.
OR during tough drive	XMTR	
Tough drive for A-axis	MTTR-A	
Tough drive for B-axis	MTTR-B	
Tough drive for C-axis	MTTR-C	
AND during fully closed loop control	CCLDS	CLDS turns on during fully closed loop control.
OR during fully closed loop control	XCLDS	
During fully closed loop control A-axis	CLDS-A	
During fully closed loop control B-axis	CLDS-B	
During fully closed loop control C-axis	CLDS-C	

3. SIGNALS AND WIRING

3.5.3 Output signal

Signal name	Symbol	Connector Pin No.	Function and application
Encoder A-phase pulse A (differential line driver)	LA-A LAR-A	CN3-3 CN3-16	The encoder output pulses set in [Pr. PA15] and [Pr. PA16] are output in differential line driver type. In CCW rotation of the servo motor, the encoder B-phase pulse lags the encoder A-phase pulse by a phase angle of $\pi/2$.
Encoder B-phase pulse A (differential line driver)	LB-A LBR-A	CN3-4 CN3-17	The relation between rotation direction and phase difference of the A-phase and B-phase pulses can be changed with [Pr. PC03]. Output pulse specification, dividing ratio setting, and electronic gear setting can be selected.
Encoder A-phase pulse B (differential line driver)	LA-B LAR-B	CN3-5 CN3-18	These signals cannot be used for MR-J4W3-_B.
Encoder B-phase pulse B (differential line driver)	LB-B LBR-B	CN3-6 CN3-19	

3.5.4 Power supply

Signal name	Symbol	Connector Pin No.	Function and application
Digital I/F power input	DICOM	CN3-23	Input 24 V DC (24 V DC \pm 10% MR-J4W2-_B: 350 mA, MR-J4W3-_B: 450 mA) for I/O interface. The power supply capacity changes depending on the number of I/O interface points to be used. For sink interface, connect + of 24 V DC external power supply. For source interface, connect - of 24 V DC external power supply.
Digital I/F common	DOCOM	CN3-26	Common terminal for input device such as EM2 of the servo amplifier. This is separated from LG. For sink interface, connect - of 24 V DC external power supply. For source interface, connect + of 24 V DC external power supply.
Control common	LG	CN3-14	This is for encoder output pulses (differential line driver).
Shield	SD	Plate	Connect the external conductor of the shielded wire.

3. SIGNALS AND WIRING

3.6 Forced stop deceleration function

POINT
●When alarms not related to the forced stop function occur, control of motor deceleration can not be guaranteed. (Refer to section 8.1.)
●When SSCNET III/H communication brake occurs, forced stop deceleration will operate. (Refer to section 3.7 (3).)
●In the torque control mode, the forced stop deceleration function is not available.

3.6.1 Forced stop deceleration function (SS1)

When EM2 is turned off, dynamic brake will start to stop the servo motor after forced stop deceleration. During this sequence, the display shows [AL. E6 Servo forced stop warning].

During normal operation, do not use EM2 (Forced stop 2) to alternate stop and run. The the servo amplifier life may be shortened.

(1) Connection diagram

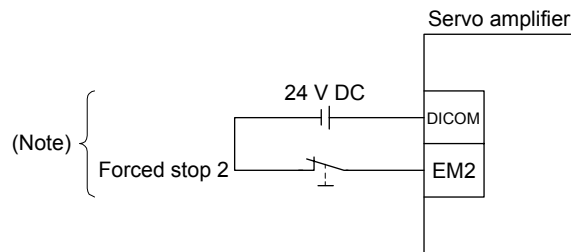

Note. This diagram is for sink I/O interface. For source I/O interface, refer to section 3.8.3.

3. SIGNALS AND WIRING

(2) Timing chart

When EM2 (Forced stop 2) turns off, the motor will decelerate according to [Pr. PC24 Forced stop deceleration time constant]. Once the motor speed is below [Pr. PC07 Zero speed], base power is cut and the dynamic brake activates. For MR-J4W_-B servo amplifiers, forced stop deceleration operates for all axes.

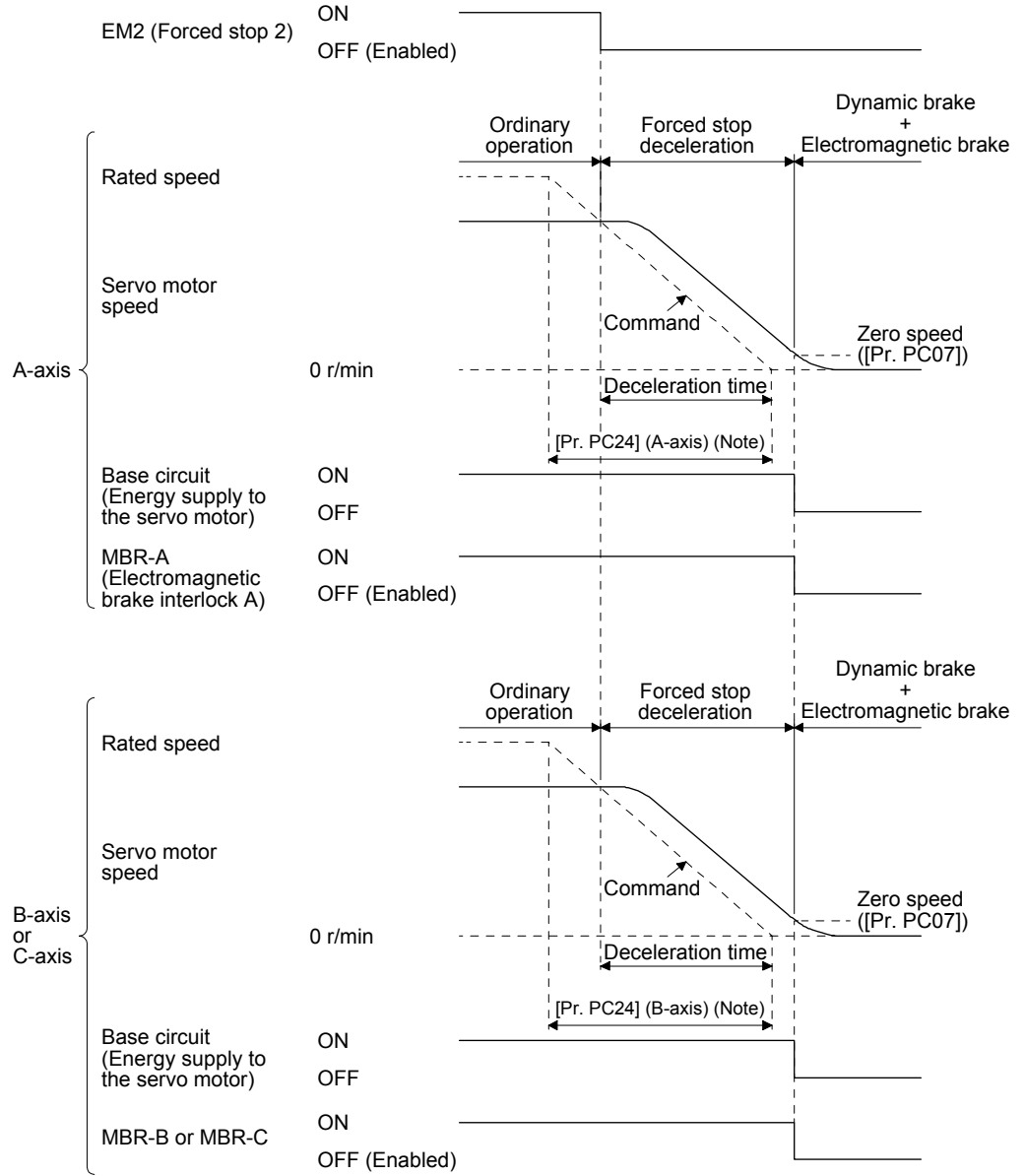

Note. To decelerate all axes of A, B, and C, set the same value to [Pr. PC24] for all axes.

3. SIGNALS AND WIRING

3.6.2 Base circuit shut-off delay time function

The base circuit shut-off delay time function is used to prevent vertical axis from dropping at a forced stop (EM2 goes off), alarm occurrence, or SSCNET III/H communication brake due to delay time of the electromagnetic brake. Set the time from MBR (Electromagnetic brake interlock) off to base circuit shut-off with [Pr. PC02].

(1) Timing chart

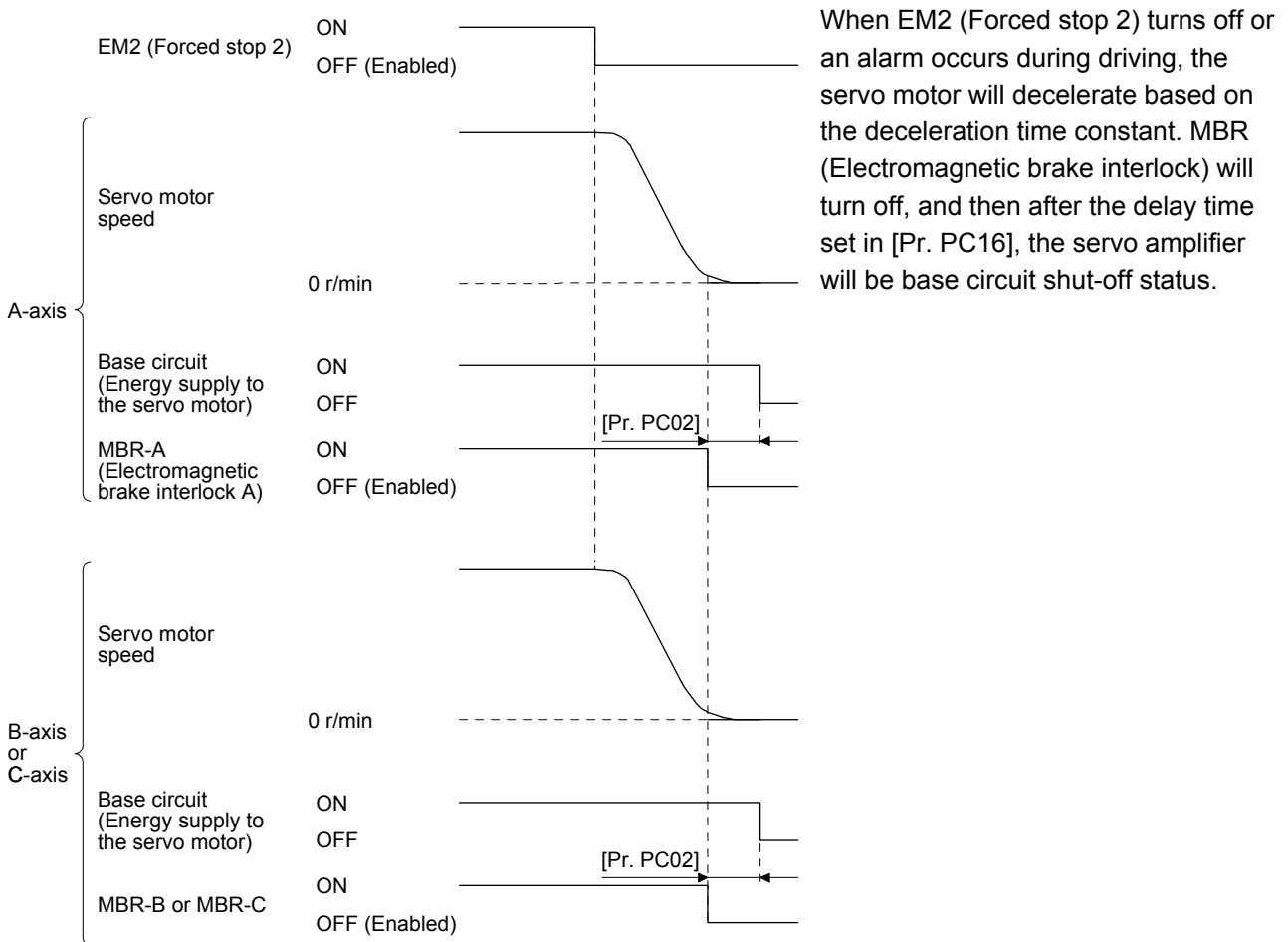

(2) Adjustment

While the servo motor is stopped, turn off EM2 (Forced stop 2), adjust the base circuit shut-off delay time in [Pr. PC16], and set the value to approximately 1.5 times of the smallest delay time in which the servo motor shaft does not freefall.

3. SIGNALS AND WIRING

3.6.3 Vertical axis freefall prevention function

The vertical axis freefall prevention function avoids machine damage by pulling up the shaft slightly like the following case.

When the servo motor is used for operating vertical axis, the servo motor electromagnetic brake and the base circuit shut-off delay time function avoid dropping axis at forced stop. However, the functions may not avoid dropping axis a few μm due to the backlash of the servo motor electromagnetic brake.

The vertical axis freefall prevention function is enabled with the following conditions.

- Other than "0" is set to [Pr. PC31 Vertical axis freefall prevention compensation amount].
- EM2 (Forced stop 2) turned off, an alarm occurred, or SSCNETIII/H communication brake occurred while the servo motor speed is zero speed or less.
- The base circuit shut-off delay time function is enabled.

(1) Timing chart

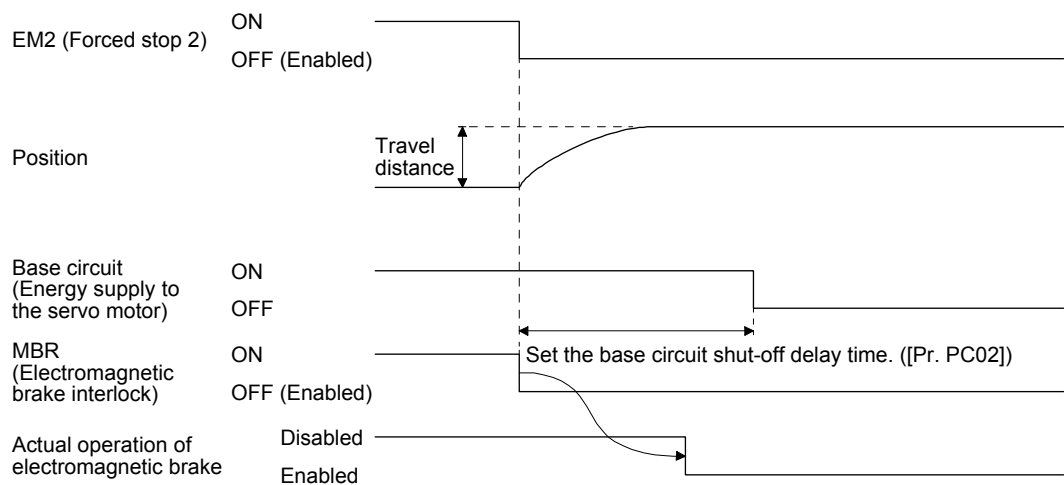

(2) Adjustment

- Set the freefall prevention compensation amount in [Pr. PC31].
- While the servo motor is stopped, turn off the EM2 (Forced stop 2). Adjust the base circuit shut-off delay time in [Pr. PC02] in accordance with the travel distance ([Pr. PC31]). Adjust it considering the freefall prevention compensation amount by checking the servo motor speed, torque ripple, etc.

3.6.4 Residual risks of the forced stop function (EM2)

- (1) The forced stop function is not available for alarms that activate the dynamic brake when the alarms occur.
- (2) When an alarm that activates the dynamic brake during forced stop deceleration occurs, the braking distance until the servo motor stops will be longer than that of normal forced stop deceleration without the dynamic brake.
- (3) If STO is turned off during forced stop deceleration, [AL.63 STO timing error] will occur.

3. SIGNALS AND WIRING

3.7 Alarm occurrence timing chart

 CAUTION	<ul style="list-style-type: none"> ● When an alarm has occurred, remove its cause, make sure that the operation signal is not being input, ensure safety, and reset the alarm before restarting operation.
	<ul style="list-style-type: none"> ● When alarms are occurring in all axes of A, B, and C, shut off the main circuit power supply. Not doing so may cause a fire when a regenerative transistor malfunctions or the like may overheat the regenerative resistor.

POINT
<ul style="list-style-type: none"> ● In the torque control mode, the forced stop deceleration function is not available.

To deactivate the alarm, cycle the control circuit power or give the error reset or CPU reset command from the servo system controller. However, the alarm cannot be deactivated unless its cause is removed.

3.7.1 When you use the forced stop deceleration function

POINT
<ul style="list-style-type: none"> ● To enable the function, set "2 ___ (initial value)" in [Pr. PA04].

(1) When the forced stop deceleration function is enabled

When an all-axis stop alarm occur, all axes will be the operation status below. When a corresponding axis stop alarm occurs, only the axis will be the operation status below. You can normally operate the axis that any alarm is not occurring.

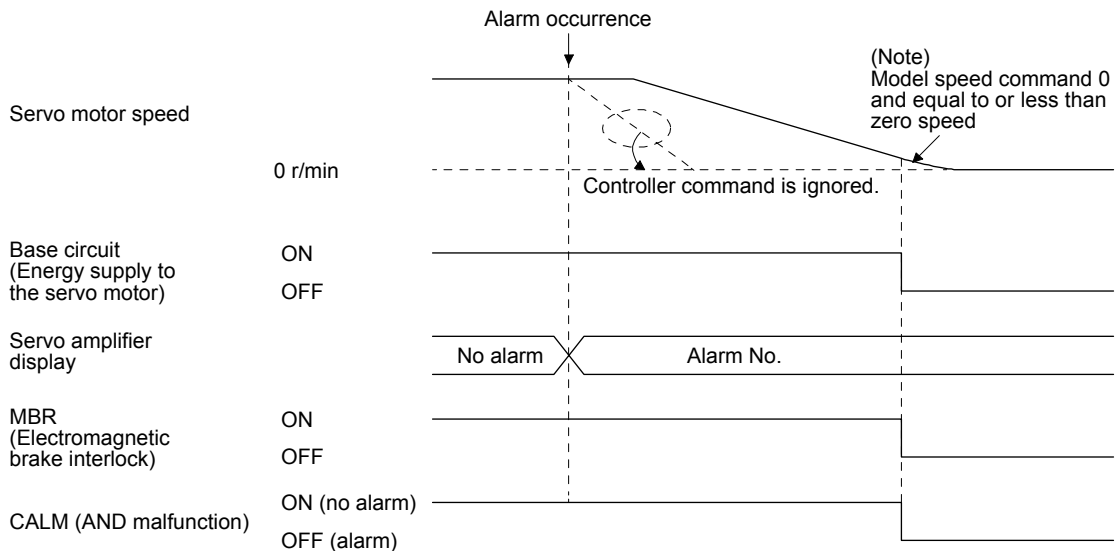

Note. The model speed command is a speed command generated in the servo amplifier for forced stop deceleration of the servo motor.

3. SIGNALS AND WIRING

(2) When the forced stop deceleration function is not enabled

When an all-axis stop alarm occur, all axes will be the operation status below. When a corresponding axis stop alarm occurs, only the axis will be the operation status below. You can normally operate the axis that any alarm is not occurring.

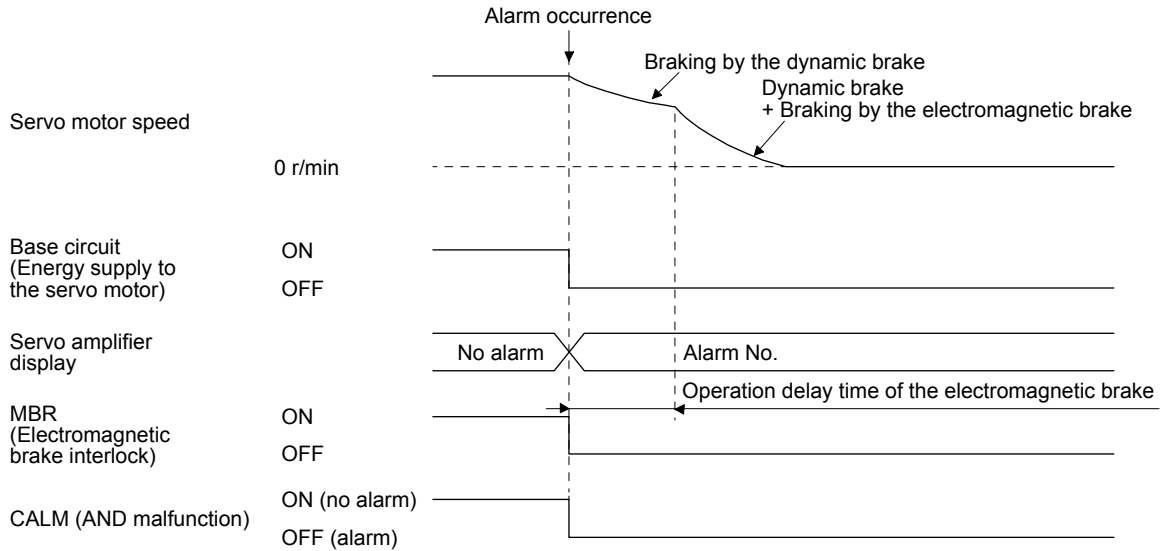

(3) When SSCNET III/H communication brake occurs

When SSCNET III/H communication is broken, all axes will be the operation status below. The dynamic brake may operate depending on the communication shut-off status.

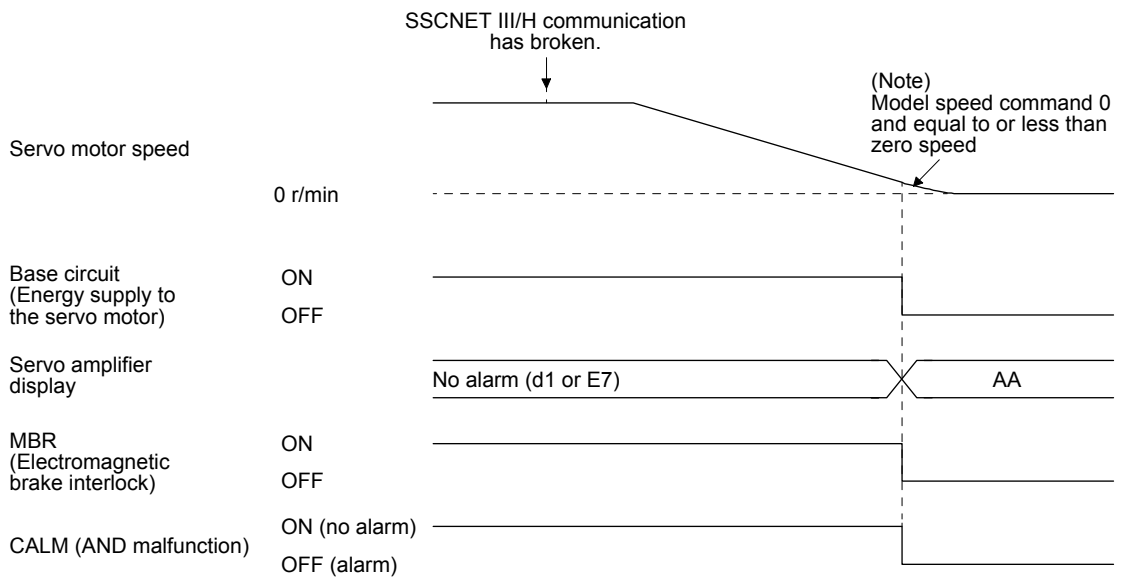

Note. The model speed command is a speed command generated in the servo amplifier for forced stop deceleration of the servo motor.

3.7.2 When you do not use the forced stop deceleration function

POINT
● To disable the function, set "0 _ _ _" in [Pr. PA04].

The timing chart that shows the servo motor condition when an alarm or SSCNETIII/H communication brake occurs is the same as section 3.7.1 (2).

3. SIGNALS AND WIRING

3.8 Interfaces

3.8.1 Internal connection diagram

POINT

● Refer to section 13.3.1 for the CN8 connector.

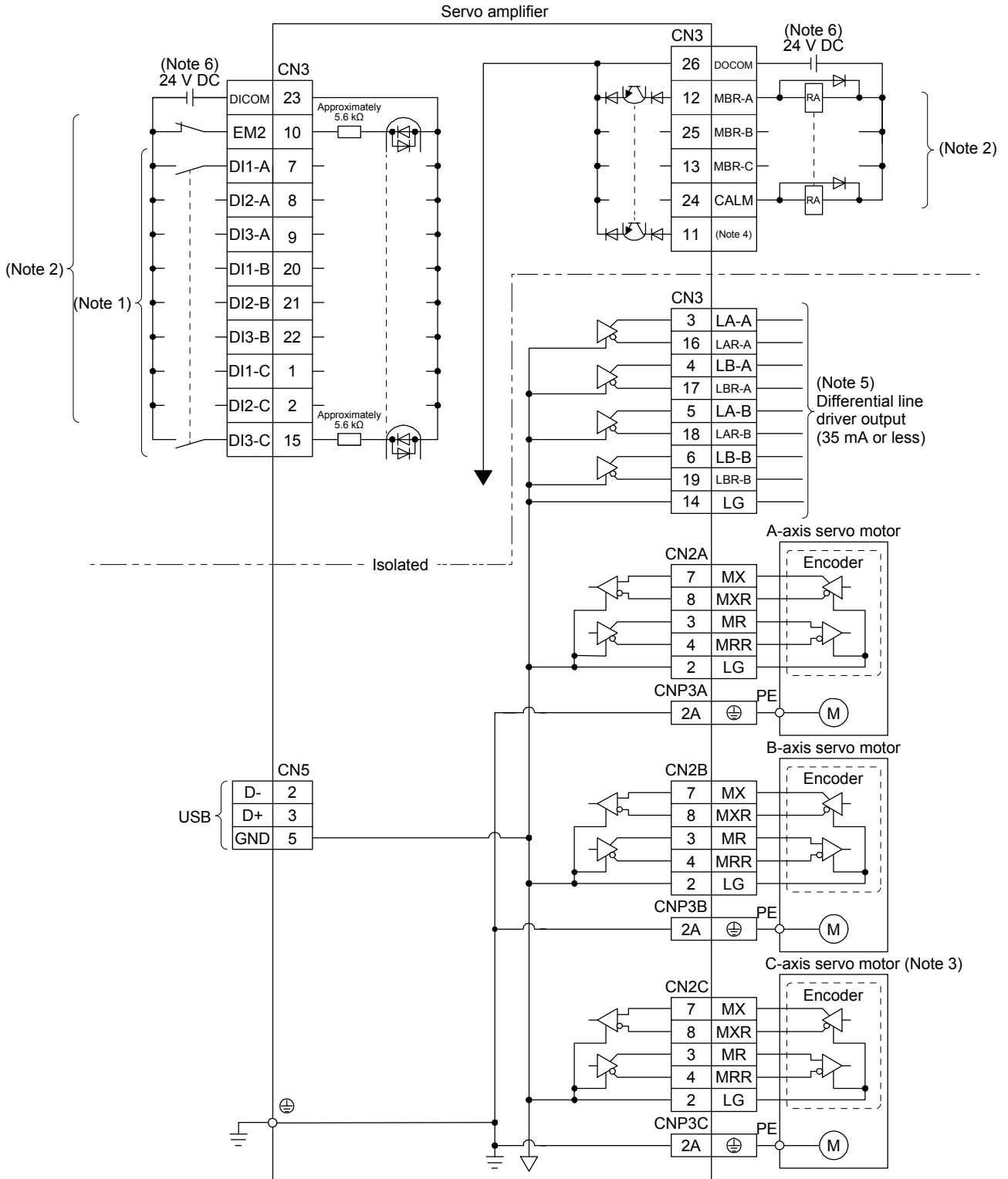

3. SIGNALS AND WIRING

- Note
1. Signal can be assigned for these pins with the controller setting.
For contents of signals, refer to the instruction manual of the controller.
 2. This diagram is for sink I/O interface. For source I/O interface, refer to section 3.8.3.
 3. For the MR-J4 3-axis servo amplifier
 4. In the initial setting, CINP (AND in-position) is assigned to the pin. You can change devices of the pin with [Pr. PD07], [Pr. PD08], and [Pr. PD09].
 5. This signal cannot be used for MR-J4W3-_B.
 6. The illustration of the 24 V DC power supply is divided between input signal and output signal for convenience. However, they can be configured by one.

3.8.2 Detailed description of interfaces

This section provides the details of the I/O signal interfaces (refer to the I/O division in the table) given in section 3.5. Refer to this section and make connection with the external device.

(1) Digital input interface DI-1

This is an input circuit whose photocoupler cathode side is input terminal. Transmit signals from sink (open-collector) type transistor output, relay switch, etc. The following is a connection diagram for sink input. Refer to section 3.8.3 for source input.

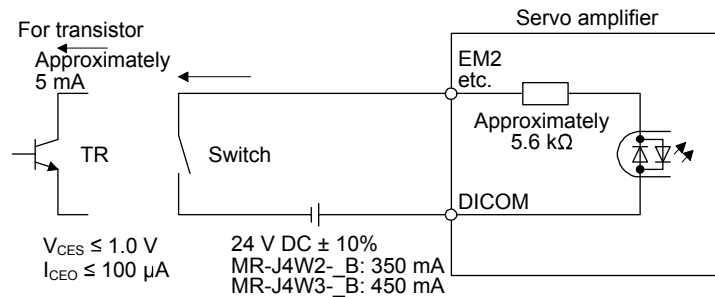

(2) Digital output interface DO-1

This is a circuit of collector output terminal of the output transistor. When the output transistor is turned on, collector terminal current will be applied for the output.

A lamp, relay or photocoupler can be driven. Install a diode (D) for an inductive load, or install an inrush current suppressing resistor (R) for a lamp load.

(Rated current: 40 mA or less, maximum current: 50 mA or less, inrush current: 100 mA or less) A maximum of 2.6 V voltage drop occurs in the servo amplifier.

The following shows a connection diagram for sink output. Refer to section 3.8.3 for source output.

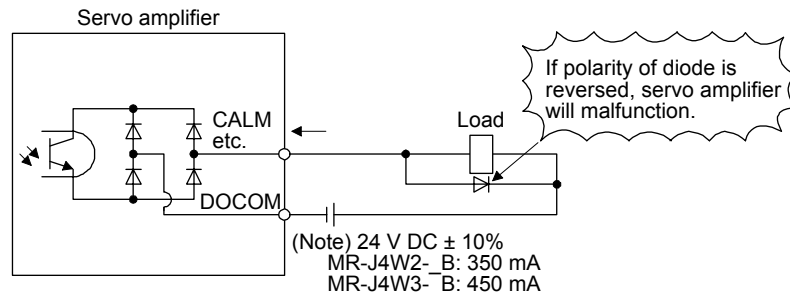

Note. If the voltage drop (maximum of 2.6 V) interferes with the relay operation, apply high voltage (maximum of 26.4 V) from external source.

3. SIGNALS AND WIRING

(3) Encoder output pulses DO-2 (differential line driver type)

(a) Interface

Maximum output current: 35 mA

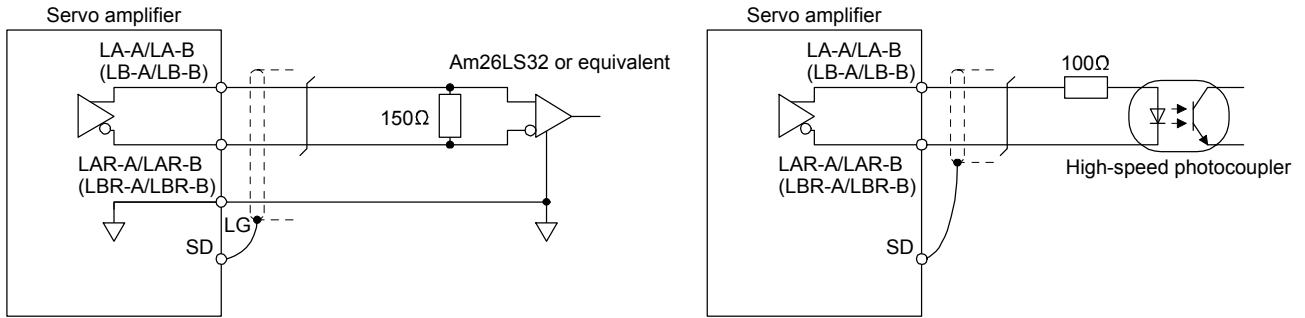

(b) Output pulse

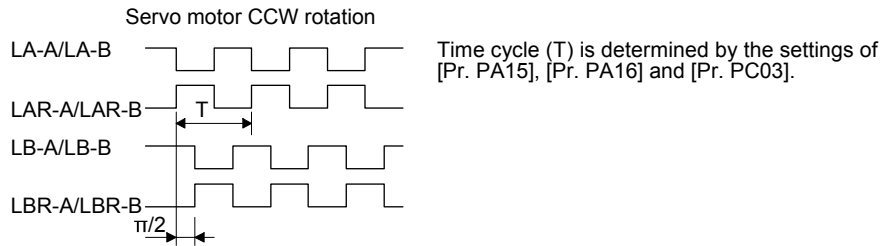

3.8.3 Source I/O interfaces

In this servo amplifier, source type I/O interfaces can be used. This is an input circuit whose photocoupler anode side is input terminal. Transmit signals from source (open-collector) type transistor output, relay switch, etc.

(1) Digital input interface DI-1

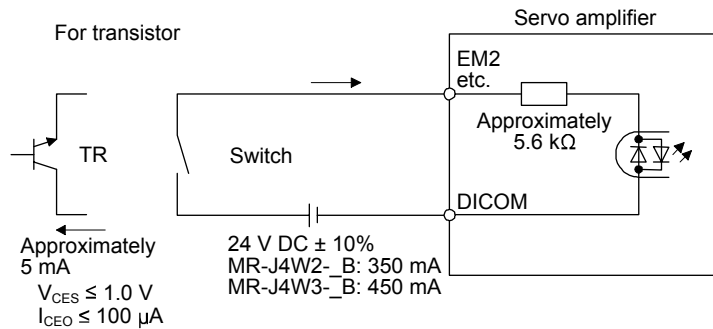

3. SIGNALS AND WIRING

(2) Digital output interface DO-1

This is a circuit of emitter output terminal of the output transistor. When the output transistor is turned on, current will be applied from the output to a load.

A maximum of 2.6 V voltage drop occurs in the servo amplifier.

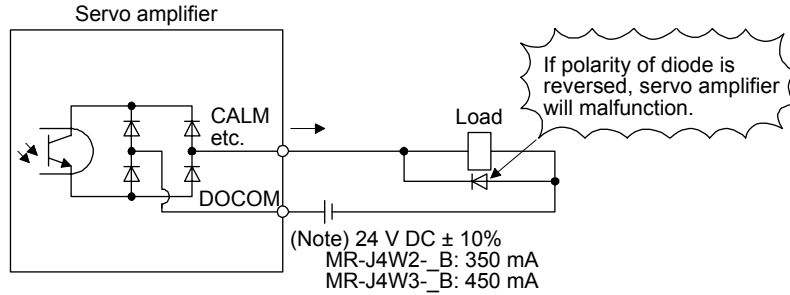

Note. If the voltage drop (maximum of 2.6 V) interferes with the relay operation, apply high voltage (maximum of 26.4 V) from external source.

3.9 SSCNET III cable connection

POINT
<ul style="list-style-type: none"> ● Do not look directly at the light generated from CN1A/CN1B connector of the servo amplifier or the end of SSCNET III cable. The light can be a discomfort when it enters the eye.

(1) SSCNET III cable connection

For the CN1A connector, connect the SSCNET III cable connected to a controller in host side or a servo amplifier of the previous axis. For CN1B connector, connect SSCNET III cable connected to servo amplifier of the next axis. For CN1B connector of the final axis, put a cap came with servo amplifier.

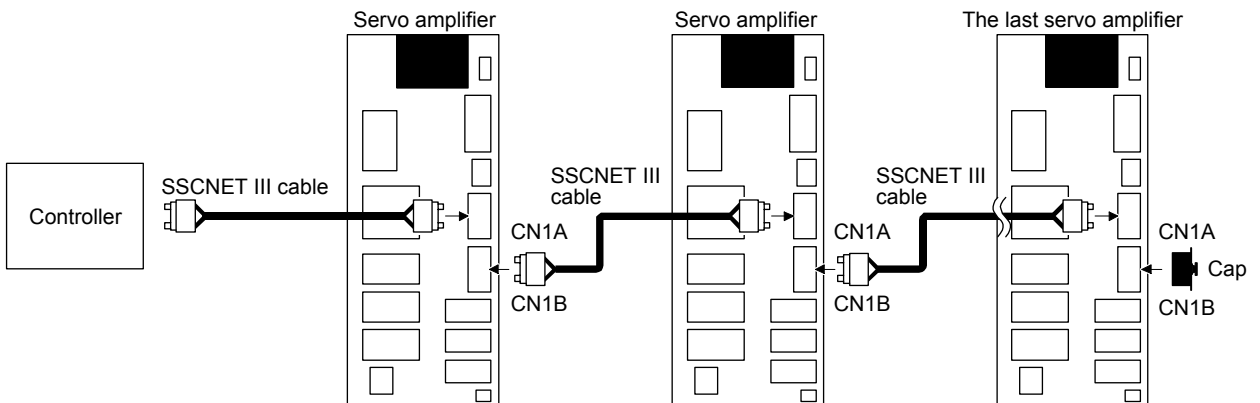

3. SIGNALS AND WIRING

(2) How to connect/disconnect cable

POINT
●CN1A and CN1B connector are capped to protect light device inside connector from dust. For this reason, do not remove a cap until just before mounting SSCNET III cable. Then, when removing SSCNET III cable, make sure to put a cap.
●Keep the cap for CN1A/CN1B connector and the tube for protecting optical cord end of SSCNET III cable in a plastic bag with a zipper of SSCNET III cable to prevent them from becoming dirty.
●When asking repair of servo amplifier for some malfunctions, make sure to cap CN1A and CN1B connector. When the connector is not put a cap, the light device may be damaged at the transit. In this case, replacing and repairing the light device is required.

(a) Connection

- 1) For SSCNET III cable in the shipping status, the tube for protect optical cord end is put on the end of connector. Remove this tube.
- 2) Remove the CN1A and CN1B connector caps of the servo amplifier.
- 3) With holding a tab of SSCNET III cable connector, make sure to insert it into the CN1A and CN1B connector of the servo amplifier until you hear the click. If the end face of optical cord tip is dirty, optical transmission is interrupted and it may cause malfunctions. If it becomes dirty, wipe with a bonded textile, etc. Do not use solvent such as alcohol.

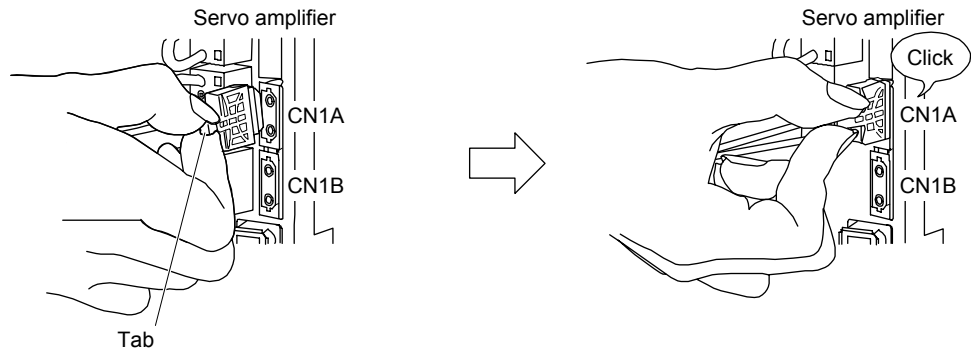

(b) Disconnection

With holding a tab of SSCNET III cable connector, pull out the connector.
When pulling out the SSCNET III cable from servo amplifier, be sure to put the cap on the connector parts of servo amplifier to prevent it from becoming dirty. For SSCNET III cable, attach the tube for protection optical cord's end face on the end of connector.

3. SIGNALS AND WIRING

3.10 Servo motor with an electromagnetic brake

3.10.1 Safety precautions

- Configure an electromagnetic brake circuit so that it is activated also by an external EMG stop switch.

Contacts must be opened when CALM (AND malfunction) or MBR (Electromagnetic brake interlock) turns off. Contacts must be opened with the EMG stop switch.

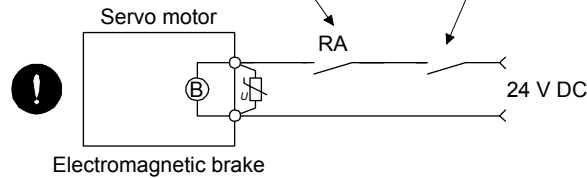

CAUTION

- The electromagnetic brake is provided for holding purpose and must not be used for ordinary braking.
- Before operating the servo motor, be sure to confirm that the electromagnetic brake operates properly.
- Do not use the 24 V DC interface power supply for the electromagnetic brake. Always use the power supply designed exclusively for the electromagnetic brake. Otherwise, it may cause a malfunction.

POINT

- Refer to the "Servo Motor Instruction Manual (Vol. 3)" for specifications such as the power supply capacity and operation delay time of the electromagnetic brake.
- Refer to the "Servo Motor Instruction Manual (Vol. 3)" or section 11.19 for the selection of a surge absorber for the electromagnetic brake.

Note the following when the servo motor with an electromagnetic brake is used.

- 1) The brake will operate when the power (24 V DC) turns off.
- 2) Turn off the servo-on command after the servo motor stopped.

3. SIGNALS AND WIRING

(1) Connection diagram

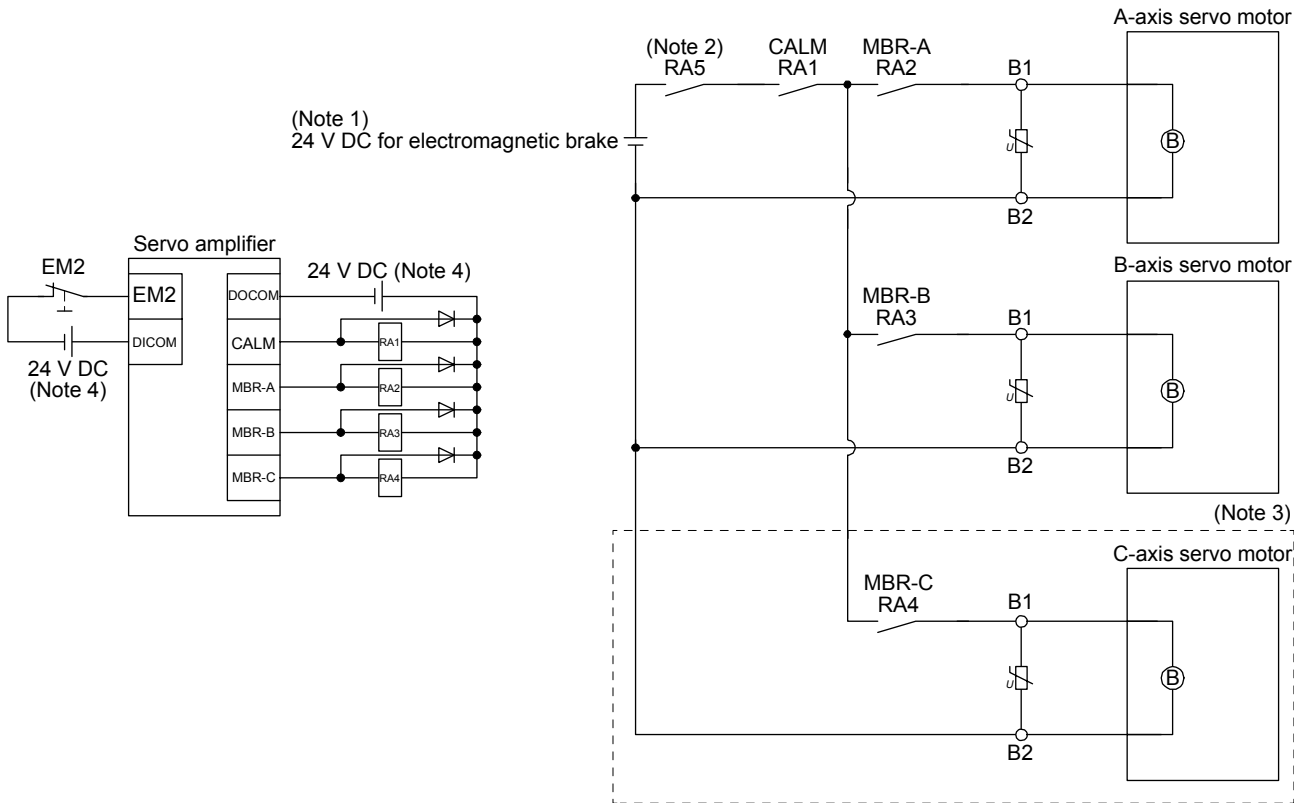

- Note 1. Do not use the 24 V DC interface power supply for the electromagnetic brake.
 Note 2. Create the circuit in order to shut off by interlocking with the emergency stop switch.
 Note 3. This connection is for the MR-J4 3-axis servo amplifier.
 Note 4. The illustration of the 24 V DC power supply is divided between input signal and output signal for convenience. However, they can be configured by one.

(2) Setting

In [Pr. PC02 Electromagnetic brake sequence output], set the time delay (Tb) from electromagnetic brake operation to base circuit shut-off at a servo-off as in the timing chart in section 3.10.2.

3. SIGNALS AND WIRING

3.10.2 Timing chart

(1) When you use the forced stop deceleration function

POINT

● To enable the function, set "2 _ _ _ (initial value)" in [Pr. PA04].

(a) Servo-on command (from controller) on/off

When servo-on command is turned off, the servo lock will be released after T_b [ms], and the servo motor will coast. If the electromagnetic brake is enabled during servo-lock, the brake life may be shorter. Therefore, set T_b about 1.5 times of the minimum delay time where the moving part will not drop down for a vertical axis system, etc.

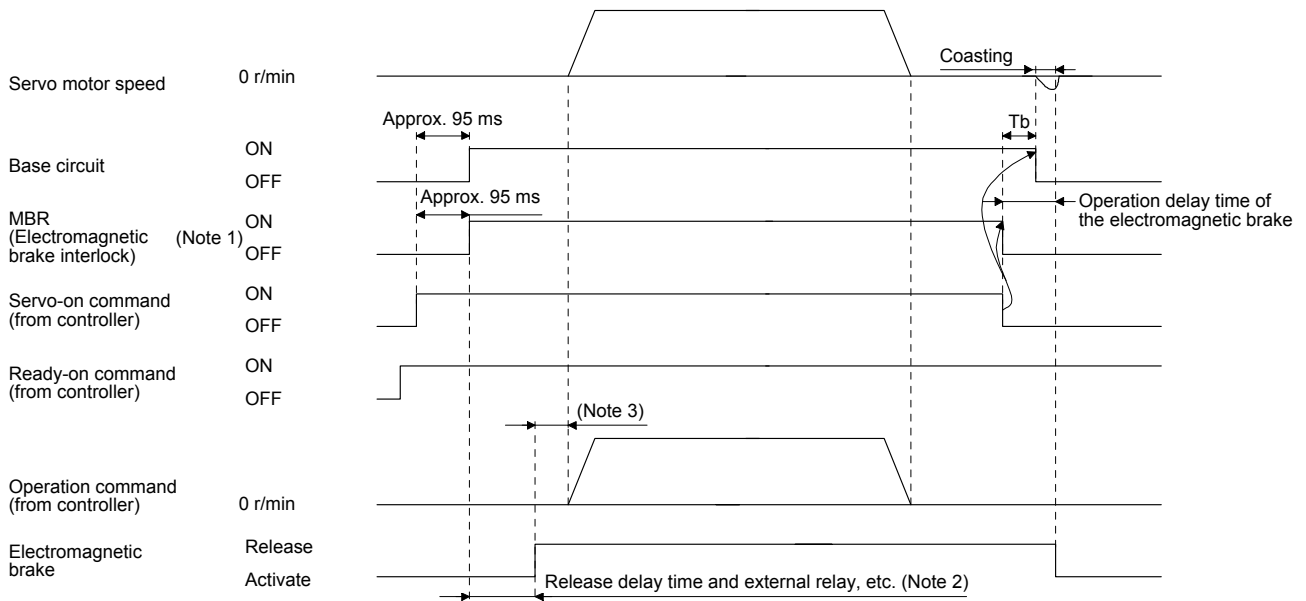

Note 1. ON : Electromagnetic brake is not activated.
OFF: Electromagnetic brake is activated.

2. Electromagnetic brake is released after delaying for the release delay time of electromagnetic brake and operation time of external circuit relay. For the release delay time of electromagnetic brake, refer to the "Servo Motor Instruction Manual (Vol. 3)".

3. Give the operation command from the controller after the electromagnetic brake is released.

3. SIGNALS AND WIRING

(b) Forced stop 2 on/off

When EM2 is turned off, all axes will be the operation status below.

POINT

● In the torque control mode, the forced stop deceleration function is not available.

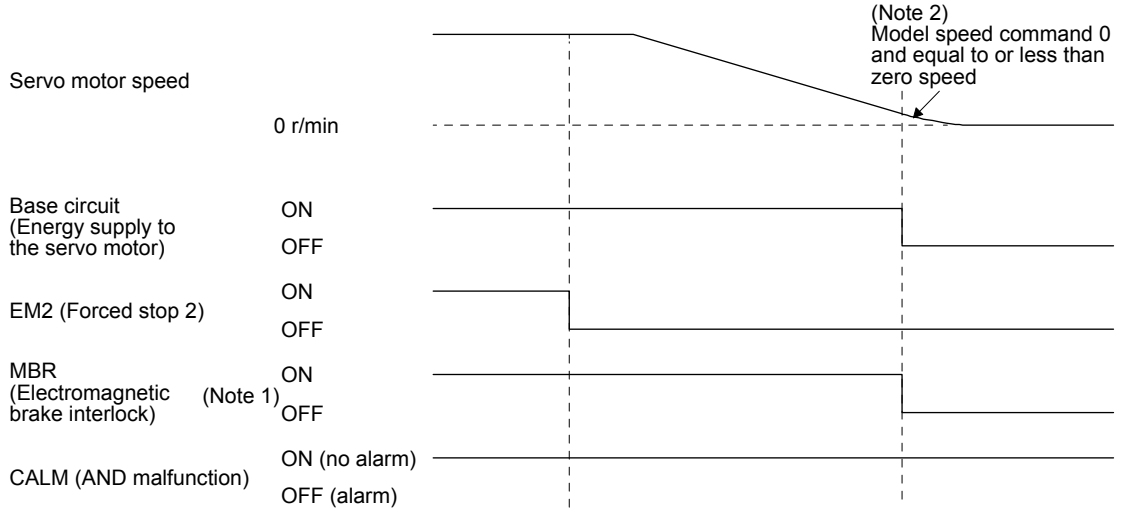

Note 1. ON : Electromagnetic brake is not activated.

OFF: Electromagnetic brake is activated.

2. The model speed command is a speed command generated in the servo amplifier for forced stop deceleration of the servo motor.

(c) Alarm occurrence

The operation status during an alarm is the same as section 3.7.

(d) Both main and control circuit power supplies off

When both main and control circuit power supplies are turned off, all axes will be the operation status below.

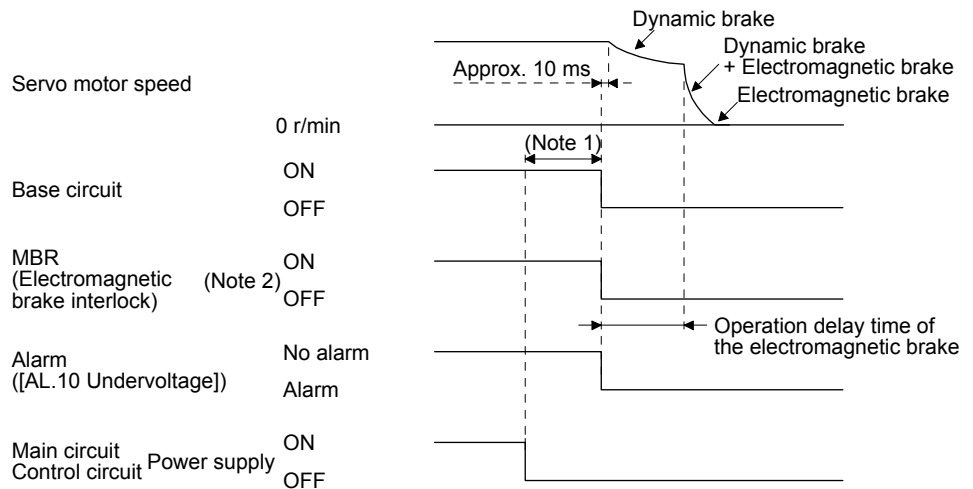

Note 1. Variable according to the operation status.

2. ON : Electromagnetic brake is not activated.

OFF: Electromagnetic brake is activated.

3. SIGNALS AND WIRING

(e) Main circuit power supply off during control circuit power supply on

When the main circuit power supply is turned off, all axes will be the operation status below.

POINT

● In the torque control mode, the forced stop deceleration function is not available.

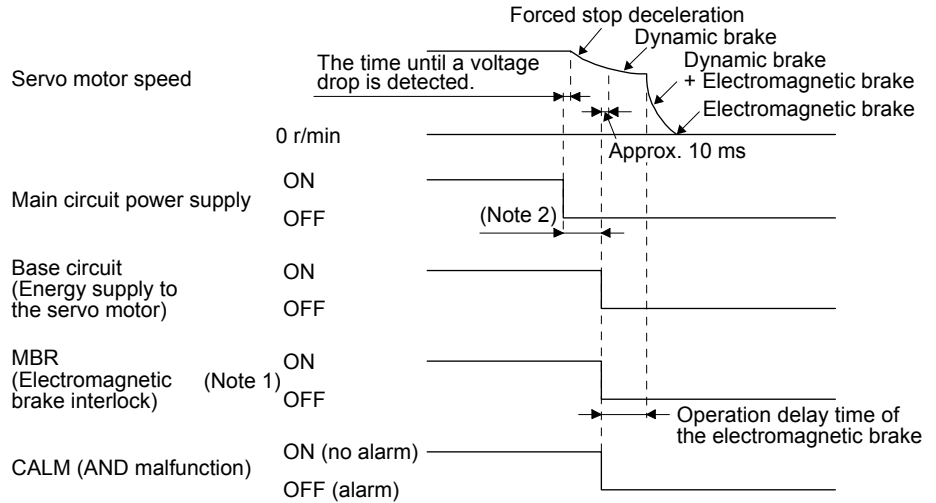

- Note 1. ON : Electromagnetic brake is not activated.
 OFF: Electromagnetic brake is activated.
2. Variable according to the operation status.

(f) Ready-off command from controller

When ready-off is received, all axes will be the operation status below.

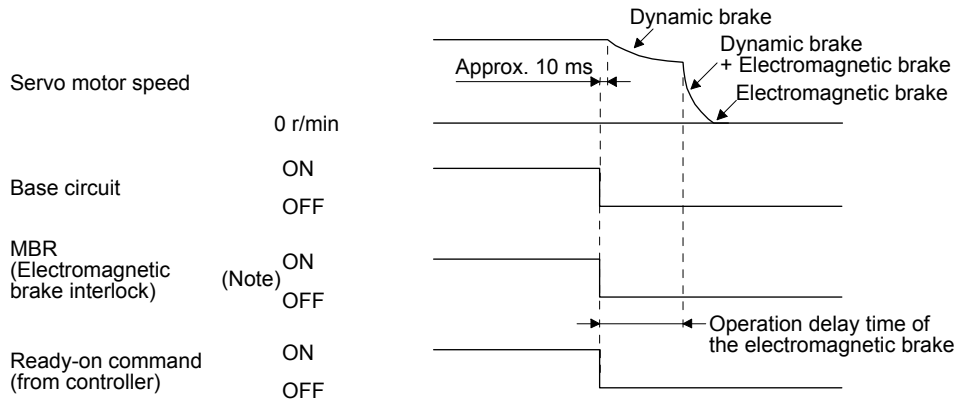

- Note. ON : Electromagnetic brake is not activated.
 OFF: Electromagnetic brake is activated.

3. SIGNALS AND WIRING

(2) When you do not use the forced stop deceleration function

POINT
● To disable the function, set "0 _ _ _" in [Pr. PA04].

(a) Servo-on command (from controller) on/off
It is the same as (1) (a) in this section.

(b) Off/on of the forced stop command (from controller) or EM1 (Forced stop)
When the controller forced stop warning is received from a controller or EM1 is turned off, all axes will be the operation status below.

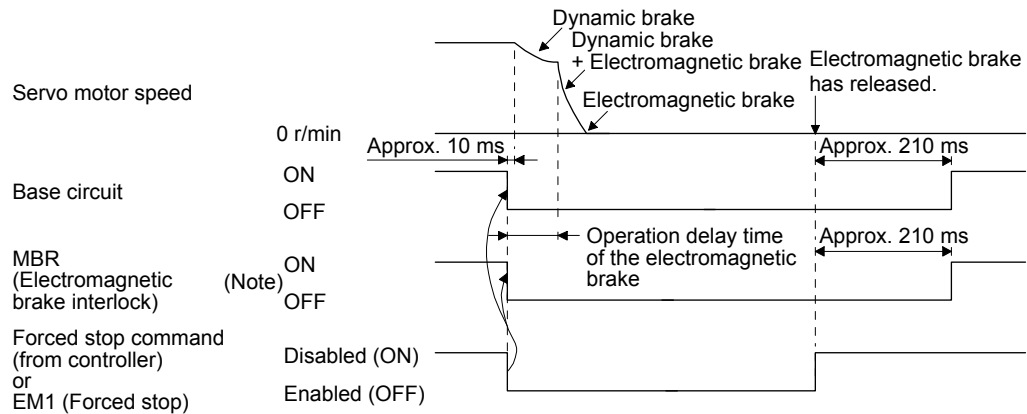

Note. ON : Electromagnetic brake is not activated.
OFF: Electromagnetic brake is activated.

(c) Alarm occurrence

The operation status during an alarm is the same as section 3.7.

(d) Both main and control circuit power supplies off

It is the same as (1) (d) in this section.

3. SIGNALS AND WIRING

(e) Main circuit power supply off during control circuit power supply on

When the main circuit power supply is turned off, all axes will be the operation status below.

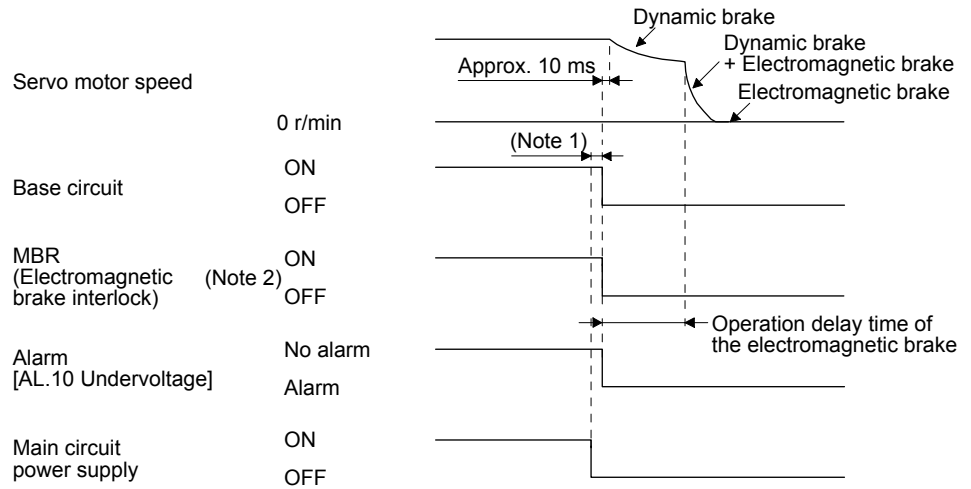

- Note 1. Variable according to the operation status.
 Note 2. ON : Electromagnetic brake is not activated.
 OFF: Electromagnetic brake is activated.

(f) Ready-off command from controller

It is the same as (1) (f) in this section.

3. SIGNALS AND WIRING

3.11 Grounding

WARNING ● Ground the servo amplifier and servo motor securely.
 ● To prevent an electric shock, always connect the protective earth (PE) terminal (marked ⊕) of the servo amplifier to the protective earth (PE) of the cabinet.

The servo amplifier switches the power transistor on-off to supply power to the servo motor. Depending on the wiring and ground cable routing, the servo amplifier may be affected by the switching noise (due to di/dt and dv/dt) of the transistor. To prevent such a fault, refer to the following diagram and always ground. To conform to the EMC Directive, refer to the EMC Installation Guidelines (IB(NA)67310).

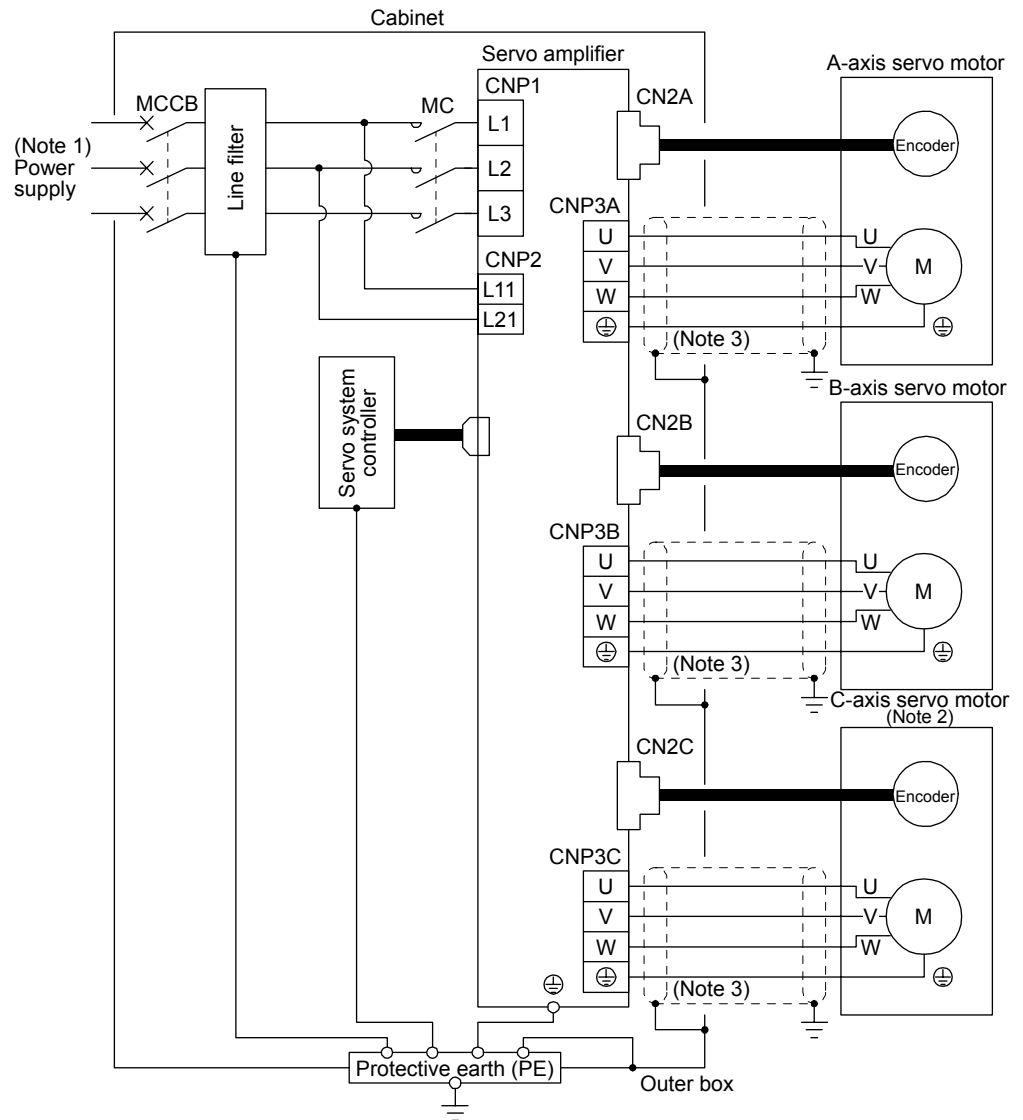

- Note 1. For 1-phase 200 V AC to 240 V AC, connect the power supply to L1 and L3. Leave L2 open. For power supply specifications, refer to section 1.3.
- Note 2. For the MR-J4 3-axis servo amplifier
- Note 3. Be sure to connect it to ⊕ of CNP3A, CNP3B, and CNP3C. Do not connect the wire directly to the protective earth of the cabinet.

4. STARTUP

4. STARTUP

 **WARNING** ● Do not operate the switches with wet hands. Otherwise, it may cause an electric shock.

 **CAUTION**

- Before starting operation, check the parameters. Improper settings may cause some machines to operate unexpectedly.
- The servo amplifier heat sink, regenerative resistor, servo motor, etc. may be hot while power is on or for some time after power-off. Take safety measures, e.g. provide covers, to prevent accidental contact of hands and parts (cables, etc.) with them.
- During operation, never touch the rotor of the servo motor. Otherwise, it may cause injury.

POINT

- When you use a linear servo motor, replace the following left words to the right words.
Load to motor inertia ratio → Load to motor mass ratio
Torque → Thrust
(Servo motor) speed → (Linear servo motor) speed

4. STARTUP

4.1 Switching power on for the first time

When switching power on for the first time, follow this section to make a startup.

4.1.1 Startup procedure

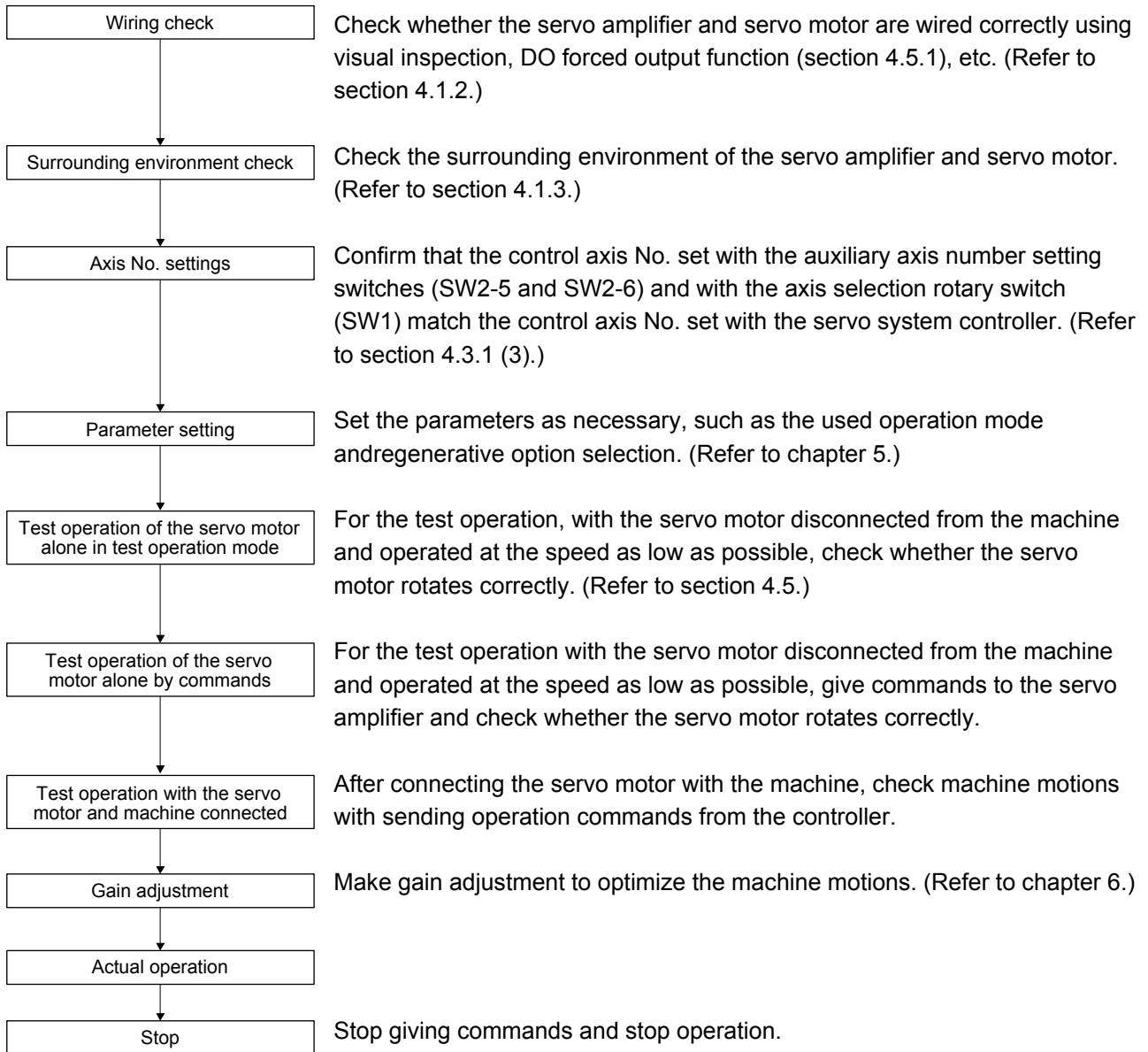

4. STARTUP

4.1.2 Wiring check

(1) Power supply system wiring

Before switching on the main circuit and control circuit power supplies, check the following items.

(a) Power supply system wiring

The power supplied to the power input terminals (L1, L2, L3, L11, and L21) of the servo amplifier should satisfy the defined specifications. (Refer to section 1.3.)

(b) Connection of servo amplifier and servo motor

- 1) The CNP3A, CNP3B, or CNP3C connector should be connected to each A-axis, B-axis, or C-axis servo motor. The servo amplifier power output (U, V, and W) should match in phase with the servo motor power input terminals (U, V, and W).

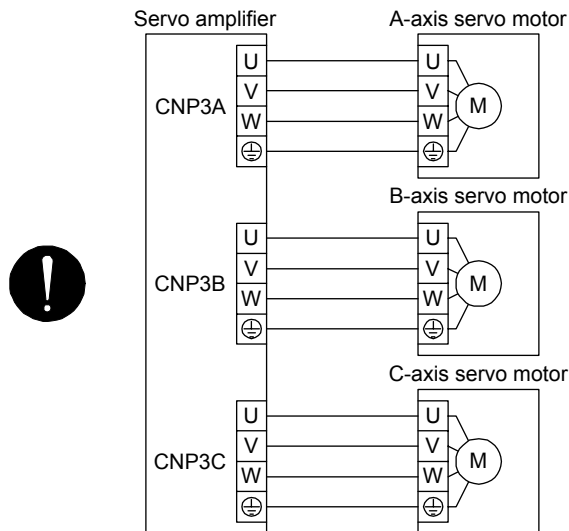

- 2) The power supplied to the servo amplifier should not be connected to the servo motor power terminals (U, V, and W). To do so will fail the connected servo amplifier and servo motor.

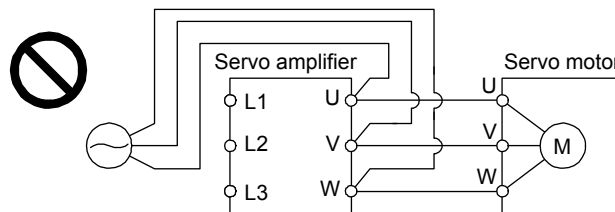

- 3) The grounding terminal of the servo motor should be connected to the PE terminal of the CNP3_ connector of the servo amplifier.

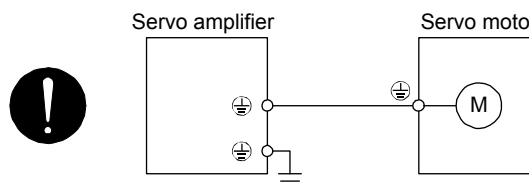

- 4) The CN2A, CN2B, or CN2C connector should be connected using encoder cables securely to each A-axis, B-axis, or C-axis encoder of the servo motors.

4. STARTUP

(c) When you use an option and auxiliary equipment

When you use a regenerative option

- The regenerative option wire should be connected between P+ terminal and C terminal.
- A twisted cable should be used. (Refer to section 11.2.4.)

(2) I/O signal wiring

(a) The I/O signals should be connected correctly.

Use DO forced output to forcibly turn on/off the pins of the CN3 connector. This function can be used to perform a wiring check. In this case, switch on the control circuit power supply only.

Refer to section 3.2 for details of I/O signal connection.

(b) 24 V DC or higher voltage is not applied to the pins of the CN3 connector.

(c) SD and DOCOM of the CN3 connector is not shorted.

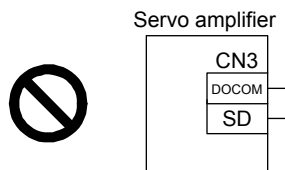

4.1.3 Surrounding environment

(1) Cable routing

(a) The wiring cables should not be stressed.

(b) The encoder cable should not be used in excess of its bending life. (Refer to section 10.4.)

(c) The connector of the servo motor should not be stressed.

(2) Environment

Signal cables and power cables are not shorted by wire offcuts, metallic dust or the like.

4.2 Startup

POINT							
●	The controller recognizes MR-J4 2-axis servo amplifiers as two servo amplifiers and 3-axis servo amplifiers as three servo amplifiers. For this reason, select "MR-J4-B" for each of the A-axis, the B-axis, and the C-axis. The following table shows the servo amplifier settings in the controller when the MR-J4 multi-axis servo amplifier is used.						
	<table border="1"> <thead> <tr> <th>Compatible controller</th> <th>Servo amplifier selection</th> </tr> </thead> <tbody> <tr> <td>Motion controller (Q173DSCPU and Q172DSCPU)</td> <td>Select "MR-J4-B" in the system setting screen.</td> </tr> <tr> <td>Simple motion module (QD77MS)</td> <td>Select "MR-J4-B" in "Servo series" [Pr. 100] of the servo parameter.</td> </tr> </tbody> </table>	Compatible controller	Servo amplifier selection	Motion controller (Q173DSCPU and Q172DSCPU)	Select "MR-J4-B" in the system setting screen.	Simple motion module (QD77MS)	Select "MR-J4-B" in "Servo series" [Pr. 100] of the servo parameter.
Compatible controller	Servo amplifier selection						
Motion controller (Q173DSCPU and Q172DSCPU)	Select "MR-J4-B" in the system setting screen.						
Simple motion module (QD77MS)	Select "MR-J4-B" in "Servo series" [Pr. 100] of the servo parameter.						

Connect the servo motor with a machine after confirming that the servo motor operates properly alone.

4. STARTUP

(1) Power on

When the main and control circuit power supplies are turned on, "b01" (for the first axis) appears on the servo amplifier display.

When the absolute position detection system is used in a rotary servo motor, first power-on results in [AL. 25 Absolute position erased] and the servo-on cannot be ready. The alarm can be deactivated by then switching power off once and on again.

Also, if power is switched on at the servo motor speed of 3000 r/min or higher, position mismatch may occur due to external force or the like. Power must therefore be switched on when the servo motor is at a stop.

(2) Parameter setting

POINT
●The following encoder cables are of four-wire type. When using any of these encoder cables, set [Pr. PC04] to "1 _ _ _" to select the four-wire type. Incorrect setting will result in [AL. 16 Encoder initial communication error 1]. MR-EKCBL30M-L MR-EKCBL30M-H MR-EKCBL40M-H MR-EKCBL50M-H

Set the parameters according to the structure and specifications of the machine. Refer to chapter 5 for details.

After setting the above parameters, switch power off as necessary. Then switch power on again to enable the parameter values.

(3) Servo-on

Enable the servo-on with the following procedure.

(a) Switch on main circuit power supply and control circuit power supply.

(b) Transmit the servo-on command with the controller.

When the servo-on status is enabled, the servo amplifier is ready to operate and the servo motor is locked.

(4) Home position return

Always perform home position return before starting positioning operation.

4. STARTUP

(5) Stop

If any of the following situations occurs, the servo amplifier suspends the running of the servo motor and brings it to a stop.

Refer to section 3.10 for the servo motor with an electromagnetic brake.

	Operation/command	Stopping condition
Servo system controller	Servo-off command	The base circuit is shut off and the servo motor coasts.
	Ready-off command	The base circuit is shut off and the dynamic brake operates to bring the servo motor to a stop.
	Forced stop command	The servo motor decelerates to a stop with the command. [AL. E7 Controller forced stop warning] occurs.
Servo amplifier	Alarm occurrence	The servo motor decelerates to a stop with the command. With some alarms, however, the dynamic brake operates to bring the servo motor to a stop. (Refer to section 8. (Note))
	EM2 (Forced stop 2) off	The servo motor decelerates to a stop with the command. [AL. E6 Servo forced stop warning] occurs. EM2 has the same device as EM1 in the torque control mode. Refer to section 3.5 for EM1.
	STO (STO1, STO2) off	The base circuit is shut off and the dynamic brake operates to bring the servo motor to a stop.

Note. Only a list of alarms and warnings is listed in chapter 8. Refer to "MELSERVO-J4 Servo Amplifier Instruction Manual (Troubleshooting)" for details of alarms and warnings.

4.3 Switch setting and display of the servo amplifier

Switching to the test operation mode, deactivating control axes, and setting control axis No. are enabled with switches on the servo amplifier.

On the servo amplifier display (three-digit, seven-segment LED), check the status of communication with the servo system controller at power-on, and the axis number, and diagnose a malfunction at occurrence of an alarm.

4.3.1 Switches



WARNING

- When switching the axis selection rotary switch (SW1) and auxiliary axis number setting switch (SW2), use an insulated screw driver. Do not use a metal screw driver. Touching patterns on electronic boards, lead of electronic parts, etc. may cause an electric shock.

POINT

- Turning "ON (up)" all the control axis setting switches (SW2) enables an operation mode for manufacturer setting and displays "off". The mode is not available. Set the control axis setting switches (SW2) correctly according to this section.
- Cycling the main circuit power supply and control circuit power supply enables the setting of each switch.

4. STARTUP

The following explains the test operation select switch, the disabling control axis switches, auxiliary axis number setting switches, and the axis selection rotary switch.

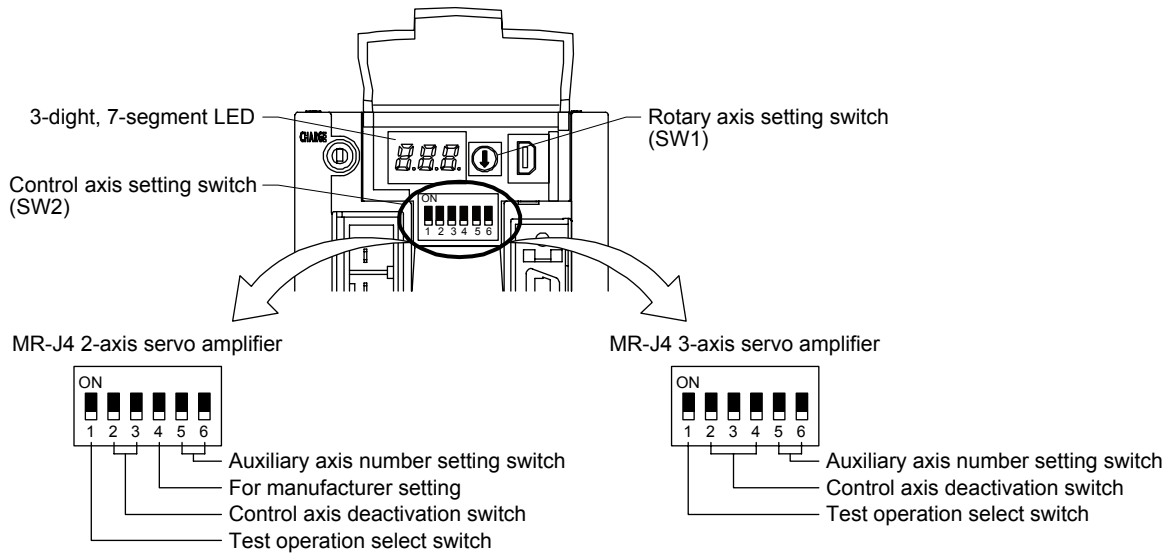

(1) Test operation select switch (SW2-1)

To use the test operation mode, turn "ON (up)" the switch. Turning "ON (up)" the switch enables the test operation mode for all axes. In the test operation mode, the functions such as JOG operation, positioning operation, and machine analyzer are available with MR Configurator2. Before turning "ON (up)" the test operation select switch, turn "OFF (down)" the disabling control axis switches.

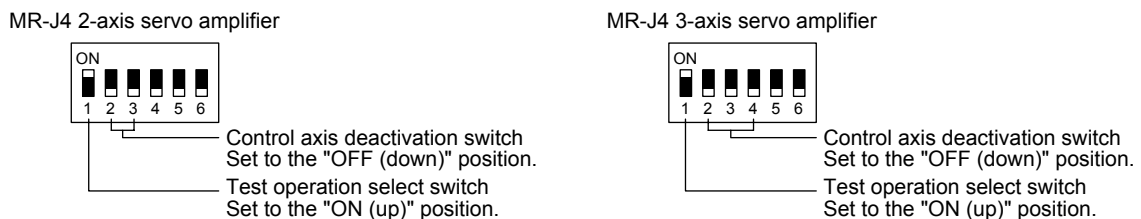

(2) Disabling control axis switches (SW2-2, SW2-3, and SW2-4)

Turning "ON (up)" a disabling control axis switch disables the corresponding servo motor. The servo motor will be disabled-axis status and will not be recognized by the controller. The following shows the disabling control axis switches for each axis.

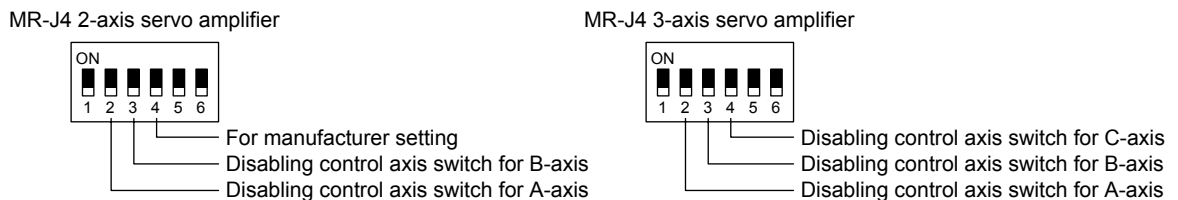

Disable the axis that you do not use. Set them from the last axis to the first axis in order. When only the first axis is disabled, [AL. 11 Switch setting error] occurs. The following lists show the enabled axes that the controller recognizes and the disabled axes that the controller do not recognize.

4. STARTUP

MR-J4 2-axis servo amplifier

MR-J4 3-axis servo amplifier

MR-J4 2-axis servo amplifier		MR-J4 3-axis servo amplifier		
Disabling control axis switch	A-axis	B-axis	C-axis	
	Enabled	Enabled		
	Enabled	Disabled		
	[AL. 11] occurs.			
	[AL. 11] occurs.			

Disabling control axis switch	A-axis	B-axis	C-axis	
	Enabled	Enabled	Enabled	
	Enabled	Enabled	Disabled	
	Enabled	Disabled	Disabled	
	[AL. 11] occurs.			

Disabling control axis switch	A-axis	B-axis	C-axis	
	[AL. 11] occurs.			
	[AL. 11] occurs.			
	[AL. 11] occurs.			
	[AL. 11] occurs.			

(3) Switches for setting control axis No.

POINT
<ul style="list-style-type: none"> ● The control axis No. set to the auxiliary axis number setting switches (SW2-5 and SW2-6) and the axis selection rotary switch (SW1) should be the same as the one set to the servo system controller. The number of the axes you can set depends on the controller. ● For setting the axis selection rotary switch, use a flat-blade screwdriver with the blade edge width of 2.1 mm to 2.3 mm and the blade edge thickness of 0.6 mm to 0.7 mm. ● When the test operation mode is selected with the test operation select switch (SW2-1), the SSCNET III/H communication for the servo amplifier in the test operation mode and the following servo amplifiers is blocked.

You can set the control axis No. between 1 and 64 by using auxiliary axis number setting switches with the axis selection rotary switch. (Refer to (3) (c) of this section.)

If the same numbers are set to different control axes in a single communication system, the system will not operate properly. The control axes may be set independently of the SSCNET III cable connection sequence. The following shows the description of each switch.

(a) Auxiliary axis number setting switches (SW2-5 and SW2-6)

Turning these switches "ON (up)" enables you to set the axis No. 17 or more.

(b) Axis selection rotary switch (SW1)

You can set the control axis No. between 1 and 64 by using auxiliary axis number setting switches with the axis selection rotary switch. (Refer to (3) (c) of this section.)

Rotary axis setting switch (SW1)

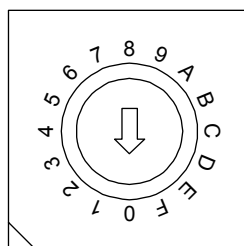

4. STARTUP

(c) Switch combination list for the control axis No. setting

The following lists show the setting combinations of the auxiliary axis number setting switches and the axis selection rotary switch.

1) MR-J4 2-axis servo amplifier

The control axis No. of A-axis is set as 1 to 63 and B-axis is set as 2 to 64.

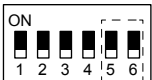
Auxiliary axis number setting switch	Axis selection rotary switch	Control axis No.	
		A-axis	B-axis
	0	1	2
	1	2	3
	2	3	4
	3	4	5
	4	5	6
	5	6	7
	6	7	8
	7	8	9
	8	9	10
	9	10	11
	A	11	12
	B	12	13
	C	13	14
	D	14	15
	E	15	16
	F	16	17

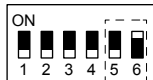
Auxiliary axis number setting switch	Axis selection rotary switch	Control axis No.	
		A-axis	B-axis
	0	17	18
	1	18	19
	2	19	20
	3	20	21
	4	21	22
	5	22	23
	6	23	24
	7	24	25
	8	25	26
	9	26	27
	A	27	28
	B	28	29
	C	29	30
	D	30	31
	E	31	32
	F	32	33

Auxiliary axis number setting switch	Axis selection rotary switch	Control axis No.	
		A-axis	B-axis
	0	33	34
	1	34	35
	2	35	36
	3	36	37
	4	37	38
	5	38	39
	6	39	40
	7	40	41
	8	41	42
	9	42	43
	A	43	44
	B	44	45
	C	45	46
	D	46	47
	E	47	48
	F	48	49

Auxiliary axis number setting switch	Axis selection rotary switch	Control axis No.	
		A-axis	B-axis
	0	49	50
	1	50	51
	2	51	52
	3	52	53
	4	53	54
	5	54	55
	6	55	56
	7	56	57
	8	57	58
	9	58	59
	A	59	60
	B	60	61
	C	61	62
	D	62	63
	E	63	64
	F		(Note)

Note. When B-axis is set as disabled-axis, A-axis is used as 64 axes. When B-axis is not set as non-axis, [AL. 11 Switch setting error] occurs.

4. STARTUP

2) MR-J4 3-axis servo amplifier

The control axis No. of A-axis is set as 1 to 62, B-axis is set as 2 to 63, and C-axis is set as 3 to 64.

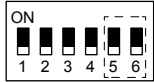
Auxiliary axis number setting switch	Axis selection rotary switch	Control axis No.		
		A-axis	B-axis	C-axis
	0	1	2	3
	1	2	3	4
	2	3	4	5
	3	4	5	6
	4	5	6	7
	5	6	7	8
	6	7	8	9
	7	8	9	10
	8	9	10	11
	9	10	11	12
	A	11	12	13
	B	12	13	14
	C	13	14	15
	D	14	15	16
	E	15	16	17
	F	16	17	18

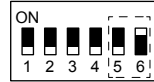
Auxiliary axis number setting switch	Axis selection rotary switch	Control axis No.		
		A-axis	B-axis	C-axis
	0	17	18	19
	1	18	19	20
	2	19	20	21
	3	20	21	22
	4	21	22	23
	5	22	23	24
	6	23	24	25
	7	24	25	26
	8	25	26	27
	9	26	27	28
	A	27	28	29
	B	28	29	30
	C	29	30	31
	D	30	31	32
	E	31	32	33
	F	32	33	34

Auxiliary axis number setting switch	Axis selection rotary switch	Control axis No.		
		A-axis	B-axis	C-axis
	0	33	34	35
	1	34	35	36
	2	35	36	37
	3	36	37	38
	4	37	38	39
	5	38	39	40
	6	39	40	41
	7	40	41	42
	8	41	42	43
	9	42	43	44
	A	43	44	45
	B	44	45	46
	C	45	46	47
	D	46	47	48
	E	47	48	49
	F	48	49	50

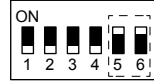
Auxiliary axis number setting switch	Axis selection rotary switch	Control axis No.		
		A-axis	B-axis	C-axis
	0	49	50	51
	1	50	51	52
	2	51	52	53
	3	52	53	54
	4	53	54	55
	5	54	55	56
	6	55	56	57
	7	56	57	58
	8	57	58	59
	9	58	59	60
	A	59	60	61
	B	60	61	62
	C	61	62	63
	D	62	63	64
	E	(Note 1)		
	F	(Note 2)		

Note 1. When C-axis is set as disabled-axis, A-axis is used as 63 axes and B-axis is used as 64-axes. When C-axis is not set as disabled-axis, [AL. 11 Switch setting error] occurs.

Note 2. When B-axis and C-axis are set as disabled-axes, A-axis is used as 64 axes. When B-axis and C-axis are not set as disabled-axes, [AL. 11 Switch setting error] occurs.

4. STARTUP

4.3.2 Scrolling display

Displaying the status of each axis in rotation enables you to check the status of all axes.

(1) Normal display

When there is no alarm, the status of all axes are displayed in rotation.

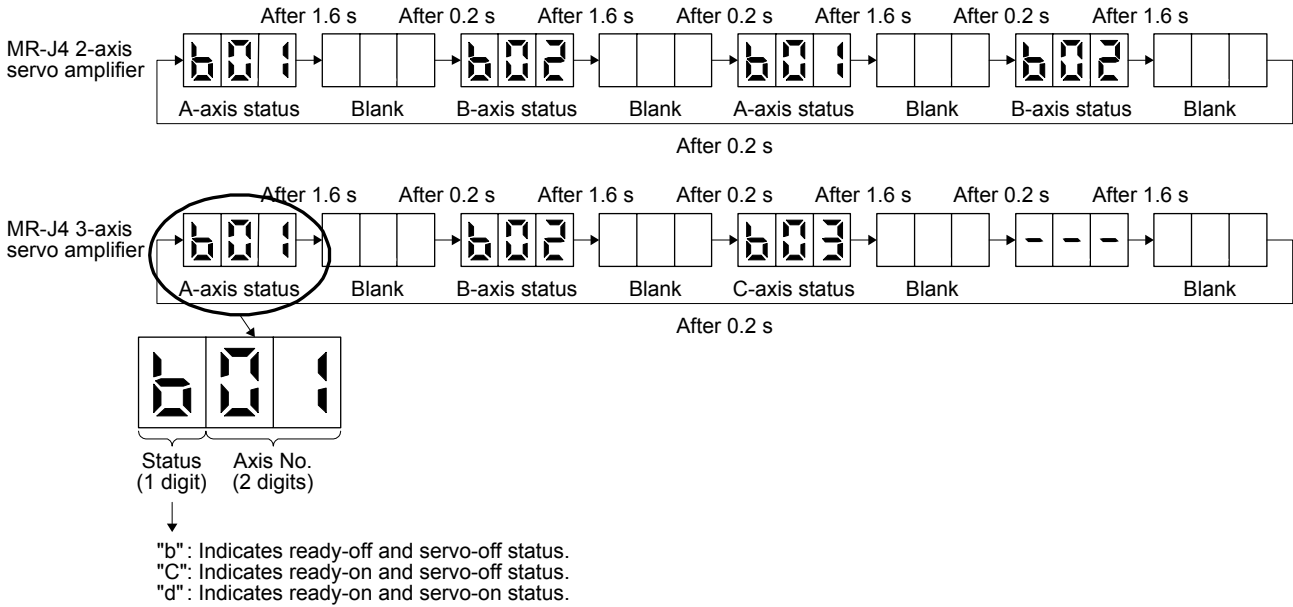

(2) Alarm display

When an alarm occurs, the alarm number (two digits) and the alarm detail (one digit) are displayed following the status display. For example, the following shows when [AL. 16 Encoder initial communication error 1] is occurring at the A-axis, and [AL. 32 Overcurrent] is occurring at the B-axis simultaneously.

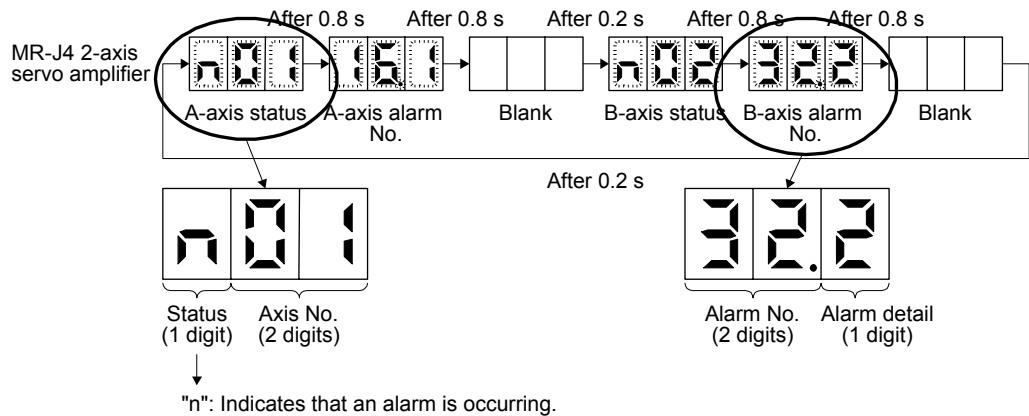

4. STARTUP

4.3.3 Status display of an axis

(1) Display sequence

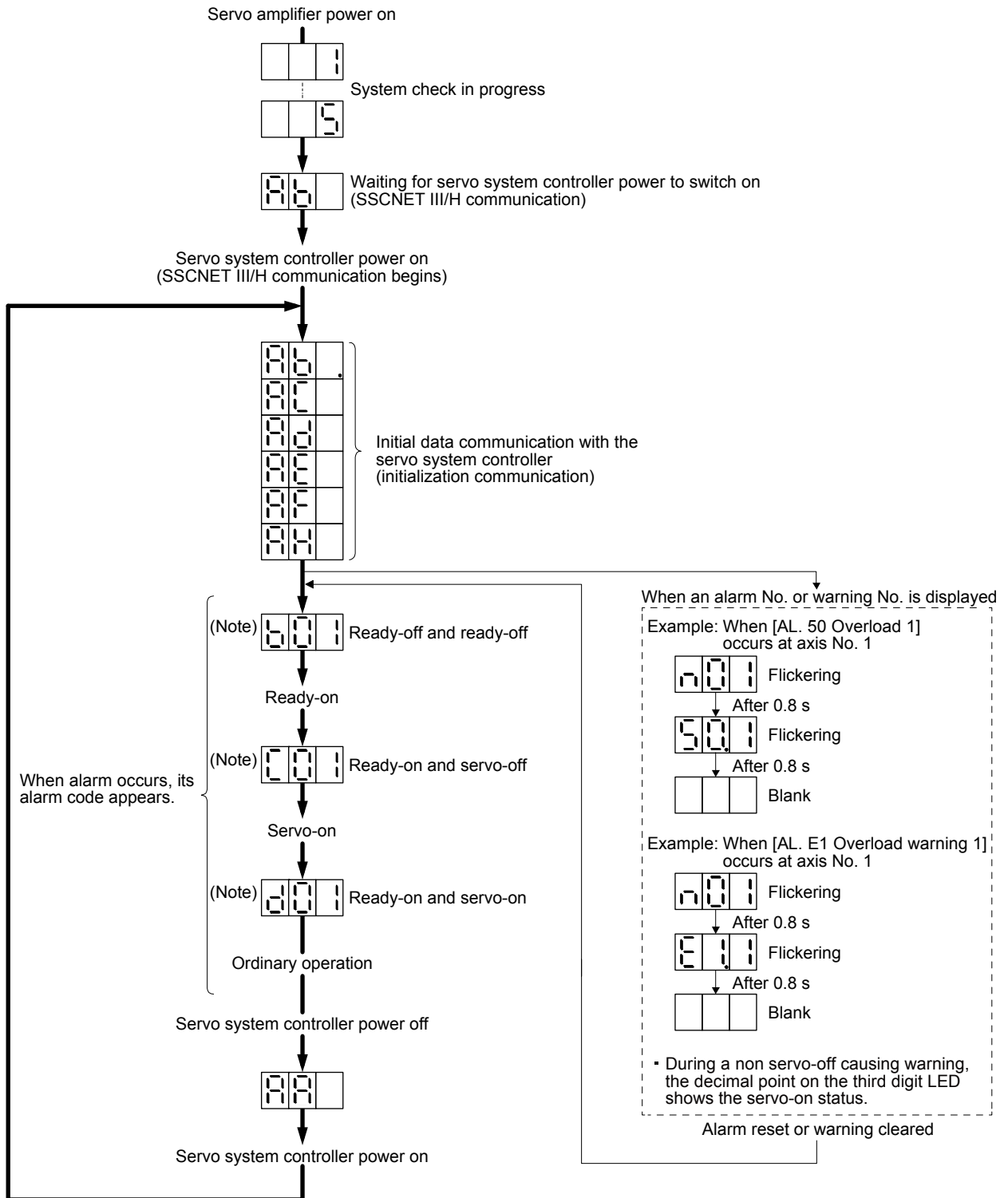











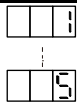





Note.

001	002	...	64
Axis No. 1	Axis No. 2		Axis No. 64

 The segment of the last 2 digits shows the axis number.

4. STARTUP

(2) Indication list

Indication	Status	Description
	Initializing	System check in progress
	Initializing	<ul style="list-style-type: none"> Power of the servo amplifier was switched on at the condition that the power of the servo system controller is off. The control axis No. set to the auxiliary axis number setting switches (SW2-5 and SW2-6) and the axis selection rotary switch (SW1) do not match the one set to the servo system controller. A servo amplifier malfunctioned, or communication error occurred with the servo system controller or the previous axis servo amplifier. In this case, the indication changes as follows. "Ab" → "AC" → "Ad" → "Ab" The servo system controller is malfunctioning.
	Initializing	During initial setting for communication specifications
	Initializing	Initial setting for communication specifications completed, and then it synchronized with servo system controller.
	Initializing	During initial parameter setting communication with servo system controller
	Initializing	During the servo motor/encoder information and telecommunication with servo system controller
	Initializing	During initial signal data communication with servo system controller
	Initializing completion	The process for initial data communication with the servo system controller is completed.
	Initializing standby	The power supply of servo system controller is turned off during the power supply of servo amplifier is on.
(Note 1) 	Ready-off	The ready off signal from the servo system controller was received.
(Note 1) 	Servo-on	The ready off signal from the servo system controller was received.
(Note 1) 	Servo-off	The ready off signal from the servo system controller was received.
(Note 2) 	Alarm/warning	The alarm No. and the warning No. that occurred is displayed. (Refer to chapter 8. (Note 4))
	CPU error	CPU watchdog error has occurred.
(Note 1)   	(Note 3) Test operation mode	Motor-less operation

Note 1. The meanings of ## are listed below.

##	Description
01	Axis No. 1
∴	∴
64	Axis No. 64

- *** indicates the alarm No. and the warning No. "A" in the third digit indicates the A-axis, "B" indicates the B-axis, and "C" indicates the C-axis.
- Only a list of alarms and warnings is listed in chapter 8. Refer to "MELSERVO-J4 Servo Amplifier Instruction Manual (Troubleshooting)" for details of alarms and warnings.

4. STARTUP

4.4 Test operation

Before starting actual operation, perform test operation to make sure that the machine operates normally. Refer to section 4.2 for the power on and off methods of the servo amplifier.

POINT

- If necessary, verify controller program by using motor-less operation. Refer to section 4.5.2 for the motor-less operation.

Test operation of the servo motor alone in JOG operation of test operation mode

In this step, confirm that the servo amplifier and servo motor operate normally. With the servo motor disconnected from the machine, use the test operation mode and check whether the servo motor rotates correctly. Refer to section 4.5 for the test operation mode.

Test operation of the servo motor alone by commands

In this step, confirm that the servo motor rotates correctly under the commands from the controller. Give a low speed command at first and check the rotation direction, etc. of the servo motor. If the machine does not operate in the intended direction, check the input signal.

Test operation with the servo motor and machine connected

In this step, connect the servo motor with the machine and confirm that the machine operates normally under the commands from the controller. Give a low speed command at first and check the operation direction, etc. of the machine. If the machine does not operate in the intended direction, check the input signal. Check any problems with the servo motor speed, load ratio, and other status display items with MR Configurator2. Then, check automatic operation with the program of the controller.

4.5 Test operation mode

CAUTION

- The test operation mode is designed for checking servo operation. It is not for checking machine operation. Do not use this mode with the machine. Always use the servo motor alone.
- If the servo motor operates abnormally, use EM2 (Forced stop 2) to stop it.

POINT

- The content described in this section indicates that the servo amplifier and a personal computer are directly connected.

By using a personal computer and MR Configurator2, you can execute jog operation, positioning operation, DO forced output program operation without connecting the servo system controller.

4. STARTUP

4.5.1 Test operation mode in MR Configurator2

POINT
<ul style="list-style-type: none"> ● All axes will be in the test operation mode for the multi-axis servo amplifier. Although only one axis is active in the mode. ● When the test operation mode is selected with the test operation select switch (SW2-1), the SSCNET III/H communication for the servo amplifier in the test operation mode and the following servo amplifiers is blocked.

(1) Test operation mode

(a) Jog operation

Jog operation can be performed without using the servo system controller. Use this operation with the forced stop reset. This operation may be used independently of whether the servo is on or off and whether the servo system controller is connected or not.

Exercise control on the jog operation screen of MR Configurator2.

1) Operation pattern

Item	Default value	Setting range
Speed [r/min]	200	0 to max. speed
Acceleration/deceleration time constant [ms]	1000	0 to 50000

2) Operation method

- When the check box of "Rotation only while the CCW or CW button is being pushed." is checked.

Operation	Screen control
Forward rotation start	Keep pressing the "Forward" button.
Reverse rotation start	Keep pressing the "Reverse" button.
Stop	Release the "Forward" or "Reverse" button.
Forced stop	Click the "Forced stop" button.

- When the check box of "Rotation only while the CCW or CW button is being pushed." is not checked.

Operation	Screen control
Forward rotation start	Click the "Forward" button.
Reverse rotation start	Click the "Reverse" button.
Stop	Click the "Stop" button.
Forced stop	Click the "Forced stop" button.

4. STARTUP

(b) Positioning operation

Positioning operation can be performed without using the servo system controller. Use this operation with the forced stop reset. This operation may be used independently of whether the servo is on or off and whether the servo system controller is connected or not.

Exercise control on the positioning operation screen of MR Configurator2.

1) Operation pattern

Item	Default value	Setting range
Travel distance [pulse]	4000	0 to 99999999
Speed [r/min]	200	0 to max. speed
Acceleration/deceleration time constant [ms]	1000	0 to 50000
Repeat pattern	Fwd. rot. (CCW) to rev. rot. (CW)	Fwd. rot. (CCW) to rev. rot. (CW) Fwd. rot. (CCW) to fwd. rot. (CCW) Rev. rot. (CW) to fwd. rot. (CCW) Rev. rot. (CW) to rev. rot. (CW)
Dwell time [s]	2.0	0.1 to 50.0
Number of repeats [time]	1	1 to 9999

2) Operation method

Operation	Screen control
Forward rotation start	Click the "Forward" button.
Reverse rotation start	Click the "Reverse" button.
Pause	Click the "Pause" button.
Stop	Click the "Stop" button.
Forced stop	Click the "Forced stop" button.

(c) Program operation

Positioning operation can be performed in two or more operation patterns combined, without using the servo system controller. Use this operation with the forced stop reset. This operation may be used independently of whether the servo is on or off and whether the servo system controller is connected or not.

Exercise control on the program operation screen of MR Configurator2. For full information, refer to the MR Configurator2 Installation Guide.

Operation	Screen control
Start	Click the "Start" button.
Pause	Click the "Pause" button.
Stop	Click the "Stop" button.
Forced stop	Click the "Forced stop" button.

(d) Output signal (DO) forced output

Output signals can be switched on/off forcibly independently of the servo status. Use this function for output signal wiring check, etc. Exercise control on the DO forced output screen of MR Configurator2.

4. STARTUP

(2) Operation procedure

- 1) Turn off the power.
- 2) Turn "ON (up)" SW2-1.

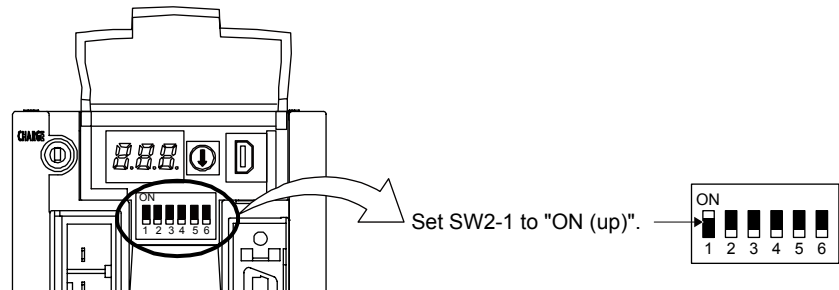

Turning "ON (up)" SW2-1 during power-on will not start the test operation mode.

3) Turn on the servo amplifier.

When initialization is completed, the decimal point on the first digit will flicker.

Example: MR-J4 2-axis servo amplifier

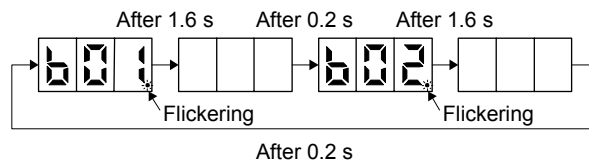

When an alarm or warning also occurs during the test operation, the decimal point will flicker.

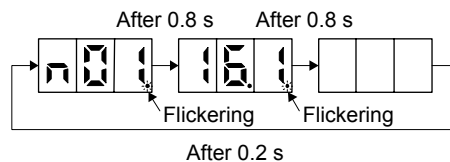

4) Start operation with the personal computer.

4.5.2 Motor-less operation in controller

POINT
<ul style="list-style-type: none"> ● Use motor-less operation which is available by making the servo system controller parameter setting. ● Connect the servo amplifier with the servo system controller before the motor-less operation. ● The motor-less operation using a controller is available with rotary servo motors only. It will be available with linear servo motors and direct drive motors in the future.

4. STARTUP

(1) Motor-less operation

Without connecting the servo motor, output signals or status displays can be provided in response to the servo system controller commands as if the servo motor is actually running. This operation may be used to check the servo system controller sequence. Use this operation with the forced stop reset. Use this operation with the servo amplifier connected to the servo system controller.

To stop the motor-less operation, set the motor-less operation selection to "Disable" in the servo parameter setting of the servo system controller. When the power supply is turned on next time, motor-less operation will be disabled.

(a) Load conditions

Load item	Condition
Load torque	0
Load to motor inertia ratio	Same as the moment of inertia of the servo motor

(b) Alarms

The following alarms and warning do not occur. However, the other alarms and warnings occur as when the servo motor is connected.

Alarm and warning	Rotary servo motor	Linear servo motor	Direct drive motor	(Note) Rotary servo motor in fully closed loop system
[AL.16 Encoder initial communication error 1]	○	○	○	○
[AL.1E Encoder initial communication error 2]	○	○	○	○
[AL.1F Encoder initial communication error 3]	○	○	○	○
[AL. 20 Encoder normal communication error 1]	○	○	○	○
[AL. 21 Encoder normal communication error 2]	○	○	○	○
[AL. 25 Absolute position erased]	○		○	○
[AL. 28 Linear encoder error 2]		○		○
[AL. 2A Linear encoder error 1]		○		○
[AL. 2B Encoder counter error]			○	
[AL. 92 Battery cable disconnection warning]	○		○	○
[AL. 9F Battery warning]	○		○	○
[AL. E9 Main circuit off warning]	○	○	○	○
[AL. 70 Load-side encoder error 1]				○
[AL. 71 Load-side encoder error 2]				○

Note. The fully closed loop system is available for the MR-J4W2-_B servo amplifiers of which software version is A3 or above. Check the software version using MR Configurator2.

4. STARTUP

(2) Operation procedure

- 1) Set the servo amplifier to the servo-off status.
- 2) Set [Pr. PC05] to "___ 1", turn "OFF (down: normal condition side)" the test operation mode switch (SW2-1), and then turn on the power supply.

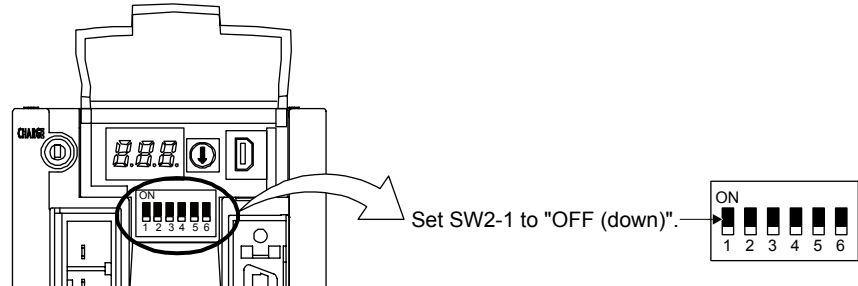

- 3) Start the motor-less operation with the servo system controller.
The display shows the following screen.

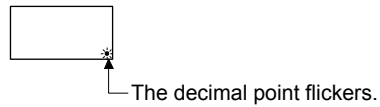

5. PARAMETERS

5. PARAMETERS

CAUTION

- Never adjust or change the parameter values extremely as it will make operation unstable.
- If fixed values are written in the digits of a parameter, do not change these values.
- Do not change parameters for manufacturer setting.
- Do not set values other than described values to each parameter.

POINT

- When you connect the amplifier to a servo system controller, servo parameter values of the servo system controller will be written to each parameters.
- Setting may not be made to some parameters and their ranges depending on the servo system controller model, servo amplifier software version, and MR Configurator2 software version. For details, refer to the servo system controller user's manual.

5.1 Parameter list

POINT

- The parameter whose symbol is preceded by * is enabled with the following conditions:
 - *: After setting the parameter, cycle the power or reset the controller.
 - ** : After setting the parameter, cycle the power.
- How to set parameters
 - Each: Set parameters for each axis of A, B, and C.
 - Common: Set parameters for common axis of A, B, and C. Be sure to set the same value to all axes.
- The same values are set as default for all axes.
- Abbreviations of operation modes indicate the followings.
 - Standard: Standard (semi closed loop system) use of the rotary servo motor
 - Full.: Fully closed loop system use of the rotary servo motor
(The fully closed loop system is available for the MR-J4-W2-_B servo amplifiers of which software version is A3 or above. Check the software version using MR Configurator2. It will not be available with MR-J4W3-_B.)
 - Lin.: Linear servo motor use.
 - D.D.: Direct drive (D.D.) motor use.

5. PARAMETERS

5.1.1 Basic setting parameters ([Pr. PA_ _])

No.	Symbol	Name	Initial value	Unit	Each/ Common	Operation mode			
						Standard	Full.	Lin.	D.D.
PA01	**STY	Operation mode	1000h		Each	<input type="radio"/>	<input type="radio"/>	<input type="radio"/>	<input type="radio"/>
PA02	**REG	Regenerative option	0000h		Common	<input type="radio"/>	<input type="radio"/>	<input type="radio"/>	<input type="radio"/>
PA03	*ABS	Absolute position detection system	0000h		Each	<input type="radio"/>	<input type="radio"/>	<input type="radio"/>	<input type="radio"/>
PA04	*AOP1	Function selection A-1	2000h		Common	<input type="radio"/>	<input type="radio"/>	<input type="radio"/>	<input type="radio"/>
PA05		For manufacturer setting	10000						
PA06			1						
PA07			1						
PA08	ATU	Auto tuning mode	0001h		Each	<input type="radio"/>	<input type="radio"/>	<input type="radio"/>	<input type="radio"/>
PA09	RSP	Auto tuning response	16		Each	<input type="radio"/>	<input type="radio"/>	<input type="radio"/>	<input type="radio"/>
PA10	INP	In-position range	1600	[pulse]	Each	<input type="radio"/>	<input type="radio"/>	<input type="radio"/>	<input type="radio"/>
PA11		For manufacturer setting	1000.0						
PA12			1000.0						
PA13			0000h						
PA14	*POL	Rotation direction selection/travel direction selection	0		Each	<input type="radio"/>	<input type="radio"/>	<input type="radio"/>	<input type="radio"/>
PA15	*ENR	Encoder output pulses	4000	[pulse/rev]	Each	<input type="radio"/>	<input type="radio"/>	<input type="radio"/>	<input type="radio"/>
PA16	*ENR2	Encoder output pulses 2	1		Each	<input type="radio"/>	<input type="radio"/>	<input type="radio"/>	<input type="radio"/>
PA17	**MSR	Servo motor series setting	0000h		Each	<input type="radio"/>	<input type="radio"/>	<input type="radio"/>	<input type="radio"/>
PA18	**MTY	Servo motor type setting	0000h		Each	<input type="radio"/>	<input type="radio"/>	<input type="radio"/>	<input type="radio"/>
PA19	*BLK	Parameter writing inhibit	00ABh		Each	<input type="radio"/>	<input type="radio"/>	<input type="radio"/>	<input type="radio"/>
PA20	*TDS	Tough drive setting	0000h		Each	<input type="radio"/>	<input type="radio"/>	<input type="radio"/>	<input type="radio"/>
PA21	*AOP3	Function selection A-3	0001h		Each	<input type="radio"/>	<input type="radio"/>	<input type="radio"/>	<input type="radio"/>
PA22		For manufacturer setting	0000h						
PA23	DRAT	Drive recorder arbitrary alarm trigger setting	0000h		Each	<input type="radio"/>	<input type="radio"/>	<input type="radio"/>	<input type="radio"/>
PA24	AOP4	Function selection A-4	0000h		Each	<input type="radio"/>	<input type="radio"/>	<input type="radio"/>	<input type="radio"/>
PA25	OTHOV	One-touch tuning - Overshoot permissible level	0	[%]	Each	<input type="radio"/>	<input type="radio"/>	<input type="radio"/>	<input type="radio"/>
PA26		For manufacturer setting	0000h						
PA27			0000h						
PA28			0000h						
PA29			0000h						
PA30			0000h						
PA31			0000h						
PA32			0000h						

5. PARAMETERS

5.1.2 Gain/filter setting parameters ([Pr. PB_ _])

No.	Symbol	Name	Initial value	Unit	Each/ Common	Operation mode			
						Standard	Full.	Lin.	D.D.
PB01	FILT	Adaptive tuning mode (adaptive filter II)	0000h		Each	<input type="radio"/>	<input type="radio"/>	<input type="radio"/>	<input type="radio"/>
PB02	VRFT	Vibration suppression control tuning mode (advanced vibration suppression control II)	0000h		Each	<input type="radio"/>	<input type="radio"/>	<input type="radio"/>	<input type="radio"/>
PB03	TFBGN	Torque feedback loop gain	18000	[rad/s]	Each	<input type="radio"/>	<input type="radio"/>	<input type="radio"/>	<input type="radio"/>
PB04	FFC	Feed forward gain	0	[%]	Each	<input type="radio"/>	<input type="radio"/>	<input type="radio"/>	<input type="radio"/>
PB05		For manufacturer setting	500			<input type="radio"/>	<input type="radio"/>	<input type="radio"/>	<input type="radio"/>
PB06	GD2	Load to motor inertia ratio/load to motor mass ratio	7.00	[Multiplier]	Each	<input type="radio"/>	<input type="radio"/>	<input type="radio"/>	<input type="radio"/>
PB07	PG1	Model loop gain	15.0	[rad/s]	Each	<input type="radio"/>	<input type="radio"/>	<input type="radio"/>	<input type="radio"/>
PB08	PG2	Position loop gain	37.0	[rad/s]	Each	<input type="radio"/>	<input type="radio"/>	<input type="radio"/>	<input type="radio"/>
PB09	VG2	Speed loop gain	823	[rad/s]	Each	<input type="radio"/>	<input type="radio"/>	<input type="radio"/>	<input type="radio"/>
PB10	VIC	Speed integral compensation	33.7	[ms]	Each	<input type="radio"/>	<input type="radio"/>	<input type="radio"/>	<input type="radio"/>
PB11	VDC	Speed differential compensation	980		Each	<input type="radio"/>	<input type="radio"/>	<input type="radio"/>	<input type="radio"/>
PB12	OVA	Overshoot amount compensation	0	[%]	Each	<input type="radio"/>	<input type="radio"/>	<input type="radio"/>	<input type="radio"/>
PB13	NH1	Machine resonance suppression filter 1	4500	[Hz]	Each	<input type="radio"/>	<input type="radio"/>	<input type="radio"/>	<input type="radio"/>
PB14	NHQ1	Notch shape selection 1	0000h		Each	<input type="radio"/>	<input type="radio"/>	<input type="radio"/>	<input type="radio"/>
PB15	NH2	Machine resonance suppression filter 2	4500	[Hz]	Each	<input type="radio"/>	<input type="radio"/>	<input type="radio"/>	<input type="radio"/>
PB16	NHQ2	Notch shape selection 2	0000h		Each	<input type="radio"/>	<input type="radio"/>	<input type="radio"/>	<input type="radio"/>
PB17	NHF	Shaft resonance suppression filter	0000h		Each	<input type="radio"/>	<input type="radio"/>	<input type="radio"/>	<input type="radio"/>
PB18	LPF	Low-pass filter setting	3141	[rad/s]	Each	<input type="radio"/>	<input type="radio"/>	<input type="radio"/>	<input type="radio"/>
PB19	VRF11	Vibration suppression control 1 - Vibration frequency	100.0	[Hz]	Each	<input type="radio"/>	<input type="radio"/>	<input type="radio"/>	<input type="radio"/>
PB20	VRF12	Vibration suppression control 1 - Resonance frequency	100.0	[Hz]	Each	<input type="radio"/>	<input type="radio"/>	<input type="radio"/>	<input type="radio"/>
PB21	VRF13	Vibration suppression control 1 - Vibration frequency damping	0.00		Each	<input type="radio"/>	<input type="radio"/>	<input type="radio"/>	<input type="radio"/>
PB22	VRF14	Vibration suppression control 1 - Resonance frequency damping	0.00		Each	<input type="radio"/>	<input type="radio"/>	<input type="radio"/>	<input type="radio"/>
PB23	VFBF	Low-pass filter selection	0000h		Each	<input type="radio"/>	<input type="radio"/>	<input type="radio"/>	<input type="radio"/>
PB24	*MVS	Slight vibration suppression control	0000h		Each	<input type="radio"/>	<input type="radio"/>	<input type="radio"/>	<input type="radio"/>
PB25		For manufacturer setting	0000h			<input type="radio"/>	<input type="radio"/>	<input type="radio"/>	<input type="radio"/>
PB26	*CDP	Gain switching function	0000h		Each	<input type="radio"/>	<input type="radio"/>	<input type="radio"/>	<input type="radio"/>
PB27	CDL	Gain switching condition	10	[kpps]/ [pulse]/ [r/min]	Each	<input type="radio"/>	<input type="radio"/>	<input type="radio"/>	<input type="radio"/>
PB28	CDT	Gain switching time constant	1	[ms]	Each	<input type="radio"/>	<input type="radio"/>	<input type="radio"/>	<input type="radio"/>
PB29	GD2B	Load to motor inertia ratio/load to motor mass ratio after gain switching	7.00	[Multiplier]	Each	<input type="radio"/>	<input type="radio"/>	<input type="radio"/>	<input type="radio"/>
PB30	PG2B	Position loop gain after gain switching	0.0	[rad/s]	Each	<input type="radio"/>	<input type="radio"/>	<input type="radio"/>	<input type="radio"/>
PB31	VG2B	Speed loop gain after gain switching	0	[rad/s]	Each	<input type="radio"/>	<input type="radio"/>	<input type="radio"/>	<input type="radio"/>
PB32	VICB	Speed integral compensation after gain switching	0.0	[ms]	Each	<input type="radio"/>	<input type="radio"/>	<input type="radio"/>	<input type="radio"/>
PB33	VRF11B	Vibration suppression control 1 - Vibration frequency after gain switching	0.0	[Hz]	Each	<input type="radio"/>	<input type="radio"/>	<input type="radio"/>	<input type="radio"/>
PB34	VRF12B	Vibration suppression control 1 - Resonance frequency after gain switching	0.0	[Hz]	Each	<input type="radio"/>	<input type="radio"/>	<input type="radio"/>	<input type="radio"/>
PB35	VRF13B	Vibration suppression control 1 - Vibration frequency damping after gain switching	0.00		Each	<input type="radio"/>	<input type="radio"/>	<input type="radio"/>	<input type="radio"/>
PB36	VRF14B	Vibration suppression control 1 - Resonance frequency damping after gain switching	0.00		Each	<input type="radio"/>	<input type="radio"/>	<input type="radio"/>	<input type="radio"/>
PB37		For manufacturer setting	1600			<input type="radio"/>	<input type="radio"/>	<input type="radio"/>	<input type="radio"/>
PB38			0.00			<input type="radio"/>	<input type="radio"/>	<input type="radio"/>	<input type="radio"/>
PB39			0.00			<input type="radio"/>	<input type="radio"/>	<input type="radio"/>	<input type="radio"/>
PB40			0.00			<input type="radio"/>	<input type="radio"/>	<input type="radio"/>	<input type="radio"/>
PB41			0			<input type="radio"/>	<input type="radio"/>	<input type="radio"/>	<input type="radio"/>
PB42			0			<input type="radio"/>	<input type="radio"/>	<input type="radio"/>	<input type="radio"/>

5. PARAMETERS

No.	Symbol	Name	Initial value	Unit	Each/ Common	Operation mode			
						Standard	Full.	Lin.	D.D.
PB43		For manufacturer setting	0000h						
PB44			0.00						
PB45	CNHF	Command notch filter	0000h		Each	<input type="radio"/>	<input type="radio"/>	<input type="radio"/>	<input type="radio"/>
PB46	NH3	Machine resonance suppression filter 3	4500	[Hz]	Each	<input type="radio"/>	<input type="radio"/>	<input type="radio"/>	<input type="radio"/>
PB47	NHQ3	Notch shape selection 3	0000h		Each	<input type="radio"/>	<input type="radio"/>	<input type="radio"/>	<input type="radio"/>
PB48	NH4	Machine resonance suppression filter 4	4500	[Hz]	Each	<input type="radio"/>	<input type="radio"/>	<input type="radio"/>	<input type="radio"/>
PB49	NHQ4	Notch shape selection 4	0000h		Each	<input type="radio"/>	<input type="radio"/>	<input type="radio"/>	<input type="radio"/>
PB50	NH5	Machine resonance suppression filter 5	4500	[Hz]	Each	<input type="radio"/>	<input type="radio"/>	<input type="radio"/>	<input type="radio"/>
PB51	NHQ5	Notch shape selection 5	0000h		Each	<input type="radio"/>	<input type="radio"/>	<input type="radio"/>	<input type="radio"/>
PB52	VRF21	Vibration suppression control 2 - Vibration frequency	100.0	[Hz]	Each	<input type="radio"/>	<input type="radio"/>	<input type="radio"/>	<input type="radio"/>
PB53	VRF22	Vibration suppression control 2 - Resonance frequency	100.0	[Hz]	Each	<input type="radio"/>	<input type="radio"/>	<input type="radio"/>	<input type="radio"/>
PB54	VRF23	Vibration suppression control 2 - Vibration frequency damping	0.00		Each	<input type="radio"/>	<input type="radio"/>	<input type="radio"/>	<input type="radio"/>
PB55	VRF24	Vibration suppression control 2 - Resonance frequency damping	0.00		Each	<input type="radio"/>	<input type="radio"/>	<input type="radio"/>	<input type="radio"/>
PB56	VRF21B	Vibration suppression control 2 - Vibration frequency after gain switching	0.0	[Hz]	Each	<input type="radio"/>	<input type="radio"/>	<input type="radio"/>	<input type="radio"/>
PB57	VRF22B	Vibration suppression control 2 - Resonance frequency after gain switching	0.0	[Hz]	Each	<input type="radio"/>	<input type="radio"/>	<input type="radio"/>	<input type="radio"/>
PB58	VRF23B	Vibration suppression control 2 - Vibration frequency damping after gain switching	0.00		Each	<input type="radio"/>	<input type="radio"/>	<input type="radio"/>	<input type="radio"/>
PB59	VRF24B	Vibration suppression control 2 - Resonance frequency damping after gain switching	0.00		Each	<input type="radio"/>	<input type="radio"/>	<input type="radio"/>	<input type="radio"/>
PB60	PG1B	Model loop gain after gain switching	0.0	[rad/s]	Each	<input type="radio"/>	<input type="radio"/>	<input type="radio"/>	<input type="radio"/>
PB61		For manufacturer setting	0.0						
PB62			0000h						
PB63			0000h						
PB64			0000h						

5.1.3 Extension setting parameters ([Pr. PC_ _])

No.	Symbol	Name	Initial value	Unit	Each/ Common	Operation mode			
						Standard	Full.	Lin.	D.D.
PC01	ERZ	Error excessive alarm level	0	[rev]/ [mm]	Each	<input type="radio"/>	<input type="radio"/>	<input type="radio"/>	<input type="radio"/>
PC02	MBR	Electromagnetic brake sequence output	0	[ms]	Each	<input type="radio"/>	<input type="radio"/>	<input type="radio"/>	<input type="radio"/>
PC03	*ENRS	Encoder output pulse selection	0000h		Each	<input type="radio"/>	<input type="radio"/>	<input type="radio"/>	<input type="radio"/>
PC04	**COP1	Function selection C-1	0000h		Each	<input type="radio"/>	<input type="radio"/>	<input type="radio"/>	<input type="radio"/>
PC05	**COP2	Function selection C-2	0000h		Each	<input type="radio"/>	<input type="radio"/>	<input type="radio"/>	<input type="radio"/>
PC06	*COP3	Function selection C-3	0000h		Each	<input type="radio"/>	<input type="radio"/>	<input type="radio"/>	<input type="radio"/>
PC07	ZSP	Zero speed	50	[r/min]/ [mm/s]	Each	<input type="radio"/>	<input type="radio"/>	<input type="radio"/>	<input type="radio"/>
PC08	OSL	Overspeed alarm detection level	0	[r/min]/ [mm/s]	Each	<input type="radio"/>	<input type="radio"/>	<input type="radio"/>	<input type="radio"/>

5. PARAMETERS

No.	Symbol	Name	Initial value	Unit	Each/ Common	Operation mode			
						Standard	Full.	Lin.	D.D.
PC09		For manufacturer setting	0000h						
PC10			0001h						
PC11			0						
PC12			0						
PC13			0						
PC14			0						
PC15			0						
PC16			0000h						
PC17	**COP4	Function selection C-4	0000h		Each	<input type="radio"/>	<input type="radio"/>	<input type="radio"/>	<input type="radio"/>
PC18	*COP5	Function selection C-5	0000h		Common	<input type="radio"/>	<input type="radio"/>	<input type="radio"/>	<input type="radio"/>
PC19		For manufacturer setting	0000h						
PC20			0000h						
PC21	*BPS	Alarm history clear	0000h		Each	<input type="radio"/>	<input type="radio"/>	<input type="radio"/>	<input type="radio"/>
PC22		For manufacturer setting	0						
PC23			0000h						
PC24	RSBR	Forced stop deceleration time constant	100	[ms]	Each	<input type="radio"/>	<input type="radio"/>	<input type="radio"/>	<input type="radio"/>
PC25		For manufacturer setting	0						
PC26			0000h						
PC27	**COP9	Function selection C-9	0000h		Each		<input type="radio"/>	<input type="radio"/>	
PC28		For manufacturer setting	0000h						
PC29			*COPB						
PC30		For manufacturer setting	0						
PC31			RSUP1						
PC32		For manufacturer setting	0000h						
PC33			0						
PC34			100						
PC35			0000h						
PC36			0000h						
PC37			0000h						
PC38			0000h						
PC39			0000h						
PC40			0000h						
PC41			0000h						
PC42			0000h						
PC43			0000h						
PC44			0000h						
PC45			0000h						
PC46			0000h						
PC47			0000h						
PC48			0000h						
PC49			0000h						
PC50			0000h						
PC51			0000h						
PC52			0000h						
PC53			0000h						
PC54			0000h						
PC55			0000h						

5. PARAMETERS

No.	Symbol	Name	Initial value	Unit	Each/ Common	Operation mode			
						Standard	Full.	Lin.	D.D.
PC56		For manufacturer setting	0000h						
PC57			0000h						
PC58			0000h						
PC59			0000h						
PC60			0000h						
PC61			0000h						
PC62			0000h						
PC63			0000h						
PC64			0000h						

5.1.4 I/O setting parameters ([Pr. PD_ _])

No.	Symbol	Name	Initial value	Unit	Each/ Common	Operation mode			
						Standard	Full.	Lin.	D.D.
PD01	*DIA2	For manufacturer setting	0000h		Each				
PD02		Input signal automatic on selection 2	0000h						
PD03		For manufacturer setting	0020h						
PD04			0021h						
PD05			0022h						
PD06			0000h						
PD07	*DO1	Output device selection 1	0005h		Each				
PD08	*DO2	Output device selection 2	0004h		Common				
PD09	*DO3	Output device selection 3	0003h		Common				
PD10		For manufacturer setting	0000h						
PD11			0004h						
PD12	*DOP1	Function selection D-1	0000h		Each				
PD13	*DOP3	For manufacturer setting	0000h						
PD14		Function selection D-3	0000h						
PD15		For manufacturer setting	0000h						
PD16			0000h						
PD17			0000h						
PD18			0000h						
PD19			0000h						
PD20			0						
PD21			0						
PD22			0						
PD23			0						
PD24			0000h						
PD25			0000h						
PD26			0000h						
PD27			0000h						
PD28			0000h						
PD29			0000h						
PD30	0								

5. PARAMETERS

No.	Symbol	Name	Initial value	Unit	Each/ Common	Operation mode			
						Standard	Full.	Lin.	D.D.
PD31		For manufacturer setting	0						
PD32			0						
PD33			0000h						
PD34			0000h						
PD35			0000h						
PD36			0000h						
PD37			0000h						
PD38			0000h						
PD39			0000h						
PD40			0000h						
PD41			0000h						
PD42			0000h						
PD43			0000h						
PD44			0000h						
PD45			0000h						
PD46			0000h						
PD47			0000h						
PD48			0000h						

5.1.5 Extension setting 2 parameters ([Pr. PE_ _])

No.	Symbol	Name	Initial value	Unit	Each/ Common	Operation mode			
						Standard	Full.	Lin.	D.D.
PE01	**FCT1	Fully closed loop function selection 1	0000h		Each		○		
PE02		For manufacturer setting	0000h						
PE03	*FCT2	Fully closed loop function selection 2	0003h		Each		○		
PE04	**FBN	Fully closed loop control - Feedback pulse electronic gear 1 - Numerator	1		Each		○		
PE05	**FBD	Fully closed loop control - Feedback pulse electronic gear 1 - Denominator	1		Each		○		
PE06	BC1	Fully closed loop control - Speed deviation error detection level	400	[r/min]	Each		○		
PE07	BC2	Fully closed loop control - Position deviation error detection level	100	[kpulse]	Each		○		
PE08	DUF	Fully closed loop dual feedback filter	10	[rad/s]	Each		○		
PE09		For manufacturer setting	0000h						
PE10	FCT3	Fully closed loop function selection 3	0000h		Each		○		
PE11		For manufacturer setting	0000h						
PE12			0000h						
PE13			0000h						
PE14			0111h						
PE15			20						
PE16			0000h						
PE17			0000h						
PE18			0000h						
PE19			0000h						
PE20			0000h						
PE21			0000h						

5. PARAMETERS

No.	Symbol	Name	Initial value	Unit	Each/ Common	Operation mode				
						Standard	Full.	Lin.	D.D.	
PE22		For manufacturer setting	0000h							
PE23			0000h							
PE24			0000h							
PE25			0000h							
PE26			0000h							
PE27			0000h							
PE28			0000h							
PE29			0000h							
PE30			0000h							
PE31			0000h							
PE32			0000h							
PE33			0000h							
PE34			**FBN2							
PE35	**FBD2	Fully closed loop control - Feedback pulse electronic gear 2 - Denominator	1		Each		○			
PE36		For manufacturer setting	0.0							
PE37			0.00							
PE38			0.00							
PE39			20							
PE40			0000h							
PE41	EOP3	Function selection E-3	0000h		Each	○	○	○	○	
PE42		For manufacturer setting	0							
PE43			0.0							
PE44			0000h							
PE45			0000h							
PE46			0000h							
PE47			0000h							
PE48			0000h							
PE49			0000h							
PE50			0000h							
PE51			0000h							
PE52			0000h							
PE53			0000h							
PE54			0000h							
PE55			0000h							
PE56			0000h							
PE57			0000h							
PE58			0000h							
PE59			0000h							
PE60			0000h							
PE61			0.00							
PE62			0.00							
PE63			0.00							
PE64			0.00							

5. PARAMETERS

5.1.6 Extension setting 3 parameters ([Pr. PF__])

No.	Symbol	Name	Initial value	Unit	Each/ Common	Operation mode			
						Standard	Full.	Lin.	D.D.
PF01		For manufacturer setting	0000h						
PF02	*FOP2	Function selection F-2	0000h		Common	<input type="radio"/>	<input type="radio"/>	<input type="radio"/>	<input type="radio"/>
PF03		For manufacturer setting	0000h						
PF04			0						
PF05			0000h						
PF06	*FOP5	Function selection F-5	0000h		Each	<input type="radio"/>	<input type="radio"/>	<input type="radio"/>	<input type="radio"/>
PF07		For manufacturer setting	0000h						
PF08			0000h						
PF09			0						
PF10			0						
PF11			0						
PF12	DBT	Electronic dynamic brake operating time	2000	[ms]	Each	<input type="radio"/>	<input type="radio"/>	<input type="radio"/>	<input type="radio"/>
PF13		For manufacturer setting	0000h						
PF14			10						
PF15			0000h						
PF16			0000h						
PF17			0000h						
PF18			0000h						
PF19			0000h						
PF20			0000h						
PF21	DRT	Drive recorder switching time setting	0	[s]	Common	<input type="radio"/>	<input type="radio"/>	<input type="radio"/>	<input type="radio"/>
PF22		For manufacturer setting	200						
PF23	OSCL1	Vibration tough drive - Oscillation detection level	50	[%]	Each	<input type="radio"/>	<input type="radio"/>	<input type="radio"/>	<input type="radio"/>
PF24	*OSCL2	Vibration tough drive function selection	0000h		Each	<input type="radio"/>	<input type="radio"/>	<input type="radio"/>	<input type="radio"/>
PF25	CVAT	SEMI-F47 function - Instantaneous power failure detection time (instantaneous power failure tough drive - detection time)	200	[ms]	Common	<input type="radio"/>	<input type="radio"/>	<input type="radio"/>	<input type="radio"/>
PF26		For manufacturer setting	0						
PF27			0						
PF28			0						
PF29			0000h						
PF30			0						
PF31	FRIC	Machine diagnosis function - Friction judgement speed	0	[r/min]/ [mm/s]	Each	<input type="radio"/>	<input type="radio"/>	<input type="radio"/>	<input type="radio"/>
PF32		For manufacturer setting	50						
PF33			0000h						
PF34			0000h						
PF35			0000h						
PF36			0000h						
PF37			0000h						
PF38			0000h						
PF39			0000h						
PF40			0000h						
PF41			0000h						
PF42			0000h						
PF43			0000h						
PF44			0000h						
PF45			0000h						
PF46			0000h						
PF47			0000h						
PF48			0000h						

5. PARAMETERS

5.1.7 Linear servo motor/DD motor setting parameters ([Pr. PL_ _])

No.	Symbol	Name	Initial value	Unit	Each/ Common	Operation mode			
						Standard	Full.	Lin.	D.D.
PL01	**LIT1	Linear servo motor/DD motor function selection 1	0301h		Each			<input type="radio"/>	<input type="radio"/>
PL02	**LIM	Linear encoder resolution - Numerator	1000	[μm]	Each			<input type="radio"/>	<input type="radio"/>
PL03	**LID	Linear encoder resolution - Denominator	1000	[μm]	Each			<input type="radio"/>	<input type="radio"/>
PL04	*LIT2	Linear servo motor/DD motor function selection 2	0003h		Each			<input type="radio"/>	<input type="radio"/>
PL05	LB1	Position deviation error detection level	0	[mm]/ [0.01 rev]	Each			<input type="radio"/>	<input type="radio"/>
PL06	LB2	Speed deviation error detection level	0	[r/min]/ [mm/s]	Each			<input type="radio"/>	<input type="radio"/>
PL07	LB3	Torque/thrust deviation error detection level	100	[%]	Each			<input type="radio"/>	<input type="radio"/>
PL08	*LIT3	Linear servo motor/DD motor function selection 3	0010h		Each			<input type="radio"/>	<input type="radio"/>
PL09	LPWM	Magnetic pole detection voltage level	30	[%]	Each			<input type="radio"/>	<input type="radio"/>
PL10		For manufacturer setting	5						
PL11			100						
PL12			500						
PL13			0000h						
PL14			0						
PL15			20						
PL16			0						
PL17	LTSTS	Magnetic pole detection - Minute position detection method - Function selection	0000h		Each			<input type="radio"/>	<input type="radio"/>
PL18	IDLV	Magnetic pole detection - Minute position detection method - Identification signal amplitude	0	[%]	Each			<input type="radio"/>	<input type="radio"/>
PL19		For manufacturer setting	0						
PL20			0						
PL21			0						
PL22			0						
PL23			0000h						
PL24			0						
PL25			0000h						
PL26			0000h						
PL27			0000h						
PL28			0000h						
PL29			0000h						
PL30			0000h						
PL31			0000h						
PL32			0000h						
PL33			0000h						
PL34			0000h						
PL35			0000h						

5. PARAMETERS

No.	Symbol	Name	Initial value	Unit	Each/ Common	Operation mode			
						Standard	Full.	Lin.	D.D.
PL36		For manufacturer setting	0000h						
PL37			0000h						
PL38			0000h						
PL39			0000h						
PL40			0000h						
PL41			0000h						
PL42			0000h						
PL43			0000h						
PL44			0000h						
PL45			0000h						
PL46			0000h						
PL47			0000h						
PL48			0000h						

5. PARAMETERS

5.2 Detailed list of parameters

POINT
● "x" in the "Setting digit" columns means which digit to set a value.

5.2.1 Basic setting parameters ([Pr. PA__])

No.	Symbol	Name and function	Initial value [unit]	Setting range	Each/ Common															
PA01	**STY	<p>Operation mode Select a operation mode.</p> <table border="1"> <thead> <tr> <th>Setting digit</th> <th>Explanation</th> <th>Initial value</th> </tr> </thead> <tbody> <tr> <td>__ _ x</td> <td>For manufacturer setting</td> <td>0h</td> </tr> <tr> <td>__ x _</td> <td>Operation mode selection 0: Standard control mode 1: Fully closed loop control mode 4. Linear servo motor control mode 6: DD motor control mode Setting other than above will result in [AL. 37 Parameter error]. The fully closed loop system is available for the MR-J4W2-_B servo amplifiers of which software version is A3 or above. It will not be available with MR-J4W3-_B servo amplifiers.</td> <td>0h</td> </tr> <tr> <td>_ x _ _</td> <td>For manufacturer setting</td> <td>0h</td> </tr> <tr> <td>x _ _ _</td> <td>Operation mode selection To change this digit, use an application software "MR-J4(W)-B mode selection". When you change it without the application, [AL. 3E Operation mode error] will occur. Set the digit as common setting. 0: J3 compatibility mode 1: J4 mode</td> <td>1h</td> </tr> </tbody> </table>	Setting digit	Explanation	Initial value	__ _ x	For manufacturer setting	0h	__ x _	Operation mode selection 0: Standard control mode 1: Fully closed loop control mode 4. Linear servo motor control mode 6: DD motor control mode Setting other than above will result in [AL. 37 Parameter error]. The fully closed loop system is available for the MR-J4W2-_B servo amplifiers of which software version is A3 or above. It will not be available with MR-J4W3-_B servo amplifiers.	0h	_ x _ _	For manufacturer setting	0h	x _ _ _	Operation mode selection To change this digit, use an application software "MR-J4(W)-B mode selection". When you change it without the application, [AL. 3E Operation mode error] will occur. Set the digit as common setting. 0: J3 compatibility mode 1: J4 mode	1h	Refer to Name and function column.		Each
Setting digit	Explanation	Initial value																		
__ _ x	For manufacturer setting	0h																		
__ x _	Operation mode selection 0: Standard control mode 1: Fully closed loop control mode 4. Linear servo motor control mode 6: DD motor control mode Setting other than above will result in [AL. 37 Parameter error]. The fully closed loop system is available for the MR-J4W2-_B servo amplifiers of which software version is A3 or above. It will not be available with MR-J4W3-_B servo amplifiers.	0h																		
_ x _ _	For manufacturer setting	0h																		
x _ _ _	Operation mode selection To change this digit, use an application software "MR-J4(W)-B mode selection". When you change it without the application, [AL. 3E Operation mode error] will occur. Set the digit as common setting. 0: J3 compatibility mode 1: J4 mode	1h																		
PA02	**REG	<p>Regenerative option Used to select the regenerative option. Incorrect setting may cause the regenerative option to burn. If a selected regenerative option is not for use with the servo amplifier, [AL. 37 Parameter error] occurs.</p> <table border="1"> <thead> <tr> <th>Setting digit</th> <th>Explanation</th> <th>Initial value</th> </tr> </thead> <tbody> <tr> <td>__ x x</td> <td>Regenerative option selection 00: Regenerative option is not used. (Built-in regenerative resistor is used.) 0B: MR-RB3N 0D: MR-RB14 0E: MR-RB34</td> <td>00h</td> </tr> <tr> <td>_ x _ _</td> <td>For manufacturer setting</td> <td>0h</td> </tr> <tr> <td>x _ _ _</td> <td></td> <td>0h</td> </tr> </tbody> </table>	Setting digit	Explanation	Initial value	__ x x	Regenerative option selection 00: Regenerative option is not used. (Built-in regenerative resistor is used.) 0B: MR-RB3N 0D: MR-RB14 0E: MR-RB34	00h	_ x _ _	For manufacturer setting	0h	x _ _ _		0h	Refer to Name and function column.		Common			
Setting digit	Explanation	Initial value																		
__ x x	Regenerative option selection 00: Regenerative option is not used. (Built-in regenerative resistor is used.) 0B: MR-RB3N 0D: MR-RB14 0E: MR-RB34	00h																		
_ x _ _	For manufacturer setting	0h																		
x _ _ _		0h																		

5. PARAMETERS

No.	Symbol	Name and function	Initial value [unit]	Setting range	Each/ Common																																			
PA03	*ABS	<p>Absolute position detection system</p> <p>Set this parameter when using the absolute position detection system. The parameter is not available in the speed control mode and torque control mode.</p> <table border="1"> <thead> <tr> <th>Setting digit</th> <th>Explanation</th> <th>Initial value</th> </tr> </thead> <tbody> <tr> <td>___x</td> <td>Absolute position detection system selection 0: Disabled (used in incremental system) 1: Enabled (used in absolute position detection system)</td> <td>0h</td> </tr> <tr> <td>__x_</td> <td rowspan="3">For manufacturer setting</td> <td>0h</td> </tr> <tr> <td>_x__</td> <td>0h</td> </tr> <tr> <td>x___</td> <td>0h</td> </tr> </tbody> </table>	Setting digit	Explanation	Initial value	___x	Absolute position detection system selection 0: Disabled (used in incremental system) 1: Enabled (used in absolute position detection system)	0h	__x_	For manufacturer setting	0h	_x__	0h	x___	0h	Refer to Name and function column.		Each																						
Setting digit	Explanation	Initial value																																						
___x	Absolute position detection system selection 0: Disabled (used in incremental system) 1: Enabled (used in absolute position detection system)	0h																																						
__x_	For manufacturer setting	0h																																						
_x__		0h																																						
x___		0h																																						
PA04	*AOP1	<p>Function selection A-1</p> <p>This is used to select the forced stop input and forced stop deceleration function.</p> <table border="1"> <thead> <tr> <th>Setting digit</th> <th>Explanation</th> <th>Initial value</th> </tr> </thead> <tbody> <tr> <td>___x</td> <td rowspan="2">For manufacturer setting</td> <td>0h</td> </tr> <tr> <td>__x_</td> <td>0h</td> </tr> <tr> <td>_x__</td> <td>Servo forced stop selection 0: Enabled (The forced stop input EM2 or EM1 is used.) 1: Disabled (The forced stop input EM2 and EM1 are not used.) Refer to table 5.1 for details.</td> <td>0h</td> </tr> <tr> <td>x___</td> <td>Forced stop deceleration function selection 0: Forced stop deceleration function disabled (EM1) 2: Forced stop deceleration function enabled (EM2) Refer to table 5.1 for details.</td> <td>2h</td> </tr> </tbody> </table> <p style="text-align: center;">Table 5.1 Deceleration method</p> <table border="1"> <thead> <tr> <th rowspan="2">Setting value</th> <th rowspan="2">EM2/EM1</th> <th colspan="2">Deceleration method</th> </tr> <tr> <th>EM2 or EM1 is off</th> <th>Alarm occurred</th> </tr> </thead> <tbody> <tr> <td>00__</td> <td>EM1</td> <td>MBR (Electromagnetic brake interlock) turns off without the forced stop deceleration.</td> <td>MBR (Electromagnetic brake interlock) turns off without the forced stop deceleration.</td> </tr> <tr> <td>20__</td> <td>EM2</td> <td>MBR (Electromagnetic brake interlock) turns off after the forced stop deceleration.</td> <td>MBR (Electromagnetic brake interlock) turns off after the forced stop deceleration.</td> </tr> <tr> <td>01__</td> <td>Not using EM2 or EM1</td> <td rowspan="2" style="text-align: center;">/</td> <td>MBR (Electromagnetic brake interlock) turns off without the forced stop deceleration.</td> </tr> <tr> <td>21__</td> <td>Not using EM2 or EM1</td> <td>MBR (Electromagnetic brake interlock) turns off after the forced stop deceleration.</td> </tr> </tbody> </table>	Setting digit	Explanation	Initial value	___x	For manufacturer setting	0h	__x_	0h	_x__	Servo forced stop selection 0: Enabled (The forced stop input EM2 or EM1 is used.) 1: Disabled (The forced stop input EM2 and EM1 are not used.) Refer to table 5.1 for details.	0h	x___	Forced stop deceleration function selection 0: Forced stop deceleration function disabled (EM1) 2: Forced stop deceleration function enabled (EM2) Refer to table 5.1 for details.	2h	Setting value	EM2/EM1	Deceleration method		EM2 or EM1 is off	Alarm occurred	00__	EM1	MBR (Electromagnetic brake interlock) turns off without the forced stop deceleration.	MBR (Electromagnetic brake interlock) turns off without the forced stop deceleration.	20__	EM2	MBR (Electromagnetic brake interlock) turns off after the forced stop deceleration.	MBR (Electromagnetic brake interlock) turns off after the forced stop deceleration.	01__	Not using EM2 or EM1	/	MBR (Electromagnetic brake interlock) turns off without the forced stop deceleration.	21__	Not using EM2 or EM1	MBR (Electromagnetic brake interlock) turns off after the forced stop deceleration.	Refer to Name and function column.		Common
Setting digit	Explanation	Initial value																																						
___x	For manufacturer setting	0h																																						
__x_		0h																																						
_x__	Servo forced stop selection 0: Enabled (The forced stop input EM2 or EM1 is used.) 1: Disabled (The forced stop input EM2 and EM1 are not used.) Refer to table 5.1 for details.	0h																																						
x___	Forced stop deceleration function selection 0: Forced stop deceleration function disabled (EM1) 2: Forced stop deceleration function enabled (EM2) Refer to table 5.1 for details.	2h																																						
Setting value	EM2/EM1	Deceleration method																																						
		EM2 or EM1 is off	Alarm occurred																																					
00__	EM1	MBR (Electromagnetic brake interlock) turns off without the forced stop deceleration.	MBR (Electromagnetic brake interlock) turns off without the forced stop deceleration.																																					
20__	EM2	MBR (Electromagnetic brake interlock) turns off after the forced stop deceleration.	MBR (Electromagnetic brake interlock) turns off after the forced stop deceleration.																																					
01__	Not using EM2 or EM1	/	MBR (Electromagnetic brake interlock) turns off without the forced stop deceleration.																																					
21__	Not using EM2 or EM1		MBR (Electromagnetic brake interlock) turns off after the forced stop deceleration.																																					

5. PARAMETERS

No.	Symbol	Name and function	Initial value [unit]	Setting range	Each/Common																		
PA08	ATU	Auto tuning mode Select the gain adjustment mode.	Refer to Name and function column.		Each																		
		<table border="1"> <thead> <tr> <th>Setting digit</th> <th>Explanation</th> <th>Initial value</th> </tr> </thead> <tbody> <tr> <td>___ x</td> <td> Gain adjustment mode selection 0: 2 gain adjustment mode 1 (interpolation mode) 1: Auto tuning mode 1 2: Auto tuning mode 2 3: Manual mode 4: 2 gain adjustment mode 2 Refer to table 5.2 for details. </td> <td>1h</td> </tr> <tr> <td>__ x _</td> <td rowspan="3">For manufacturer setting</td> <td>0h</td> </tr> <tr> <td>_ x _ _</td> <td>0h</td> </tr> <tr> <td>x _ _ _</td> <td>0h</td> </tr> </tbody> </table>				Setting digit	Explanation	Initial value	___ x	Gain adjustment mode selection 0: 2 gain adjustment mode 1 (interpolation mode) 1: Auto tuning mode 1 2: Auto tuning mode 2 3: Manual mode 4: 2 gain adjustment mode 2 Refer to table 5.2 for details.	1h	__ x _	For manufacturer setting	0h	_ x _ _	0h	x _ _ _	0h					
Setting digit	Explanation	Initial value																					
___ x	Gain adjustment mode selection 0: 2 gain adjustment mode 1 (interpolation mode) 1: Auto tuning mode 1 2: Auto tuning mode 2 3: Manual mode 4: 2 gain adjustment mode 2 Refer to table 5.2 for details.	1h																					
__ x _	For manufacturer setting	0h																					
_ x _ _		0h																					
x _ _ _		0h																					
Table 5.2 Gain adjustment mode selection																							
		<table border="1"> <thead> <tr> <th>Setting value</th> <th>Gain adjustment mode</th> <th>Automatically adjusted parameter</th> </tr> </thead> <tbody> <tr> <td>___ 0</td> <td>2 gain adjustment mode 1 (interpolation mode)</td> <td> [Pr. PB06 Load to motor inertia ratio/load to motor mass ratio] [Pr. PB08 Position loop gain] [Pr. PB09 Speed loop gain] [Pr. PB10 Speed integral compensation] </td> </tr> <tr> <td>___ 1</td> <td>Auto tuning mode 1</td> <td> [Pr. PB06 Load to motor inertia ratio/load to motor mass ratio] [Pr. PB07 Model loop gain] [Pr. PB08 Position loop gain] [Pr. PB09 Speed loop gain] [Pr. PB10 Speed integral compensation] </td> </tr> <tr> <td>___ 2</td> <td>Auto tuning mode 2</td> <td> [Pr. PB07 Model loop gain] [Pr. PB08 Position loop gain] [Pr. PB09 Speed loop gain] [Pr. PB10 Speed integral compensation] </td> </tr> <tr> <td>___ 3</td> <td>Manual mode</td> <td></td> </tr> <tr> <td>___ 4</td> <td>2 gain adjustment mode 2</td> <td> [Pr. PB08 Position loop gain] [Pr. PB09 Speed loop gain] [Pr. PB10 Speed integral compensation] </td> </tr> </tbody> </table>	Setting value	Gain adjustment mode	Automatically adjusted parameter	___ 0	2 gain adjustment mode 1 (interpolation mode)	[Pr. PB06 Load to motor inertia ratio/load to motor mass ratio] [Pr. PB08 Position loop gain] [Pr. PB09 Speed loop gain] [Pr. PB10 Speed integral compensation]	___ 1	Auto tuning mode 1	[Pr. PB06 Load to motor inertia ratio/load to motor mass ratio] [Pr. PB07 Model loop gain] [Pr. PB08 Position loop gain] [Pr. PB09 Speed loop gain] [Pr. PB10 Speed integral compensation]	___ 2	Auto tuning mode 2	[Pr. PB07 Model loop gain] [Pr. PB08 Position loop gain] [Pr. PB09 Speed loop gain] [Pr. PB10 Speed integral compensation]	___ 3	Manual mode		___ 4	2 gain adjustment mode 2	[Pr. PB08 Position loop gain] [Pr. PB09 Speed loop gain] [Pr. PB10 Speed integral compensation]			
Setting value	Gain adjustment mode	Automatically adjusted parameter																					
___ 0	2 gain adjustment mode 1 (interpolation mode)	[Pr. PB06 Load to motor inertia ratio/load to motor mass ratio] [Pr. PB08 Position loop gain] [Pr. PB09 Speed loop gain] [Pr. PB10 Speed integral compensation]																					
___ 1	Auto tuning mode 1	[Pr. PB06 Load to motor inertia ratio/load to motor mass ratio] [Pr. PB07 Model loop gain] [Pr. PB08 Position loop gain] [Pr. PB09 Speed loop gain] [Pr. PB10 Speed integral compensation]																					
___ 2	Auto tuning mode 2	[Pr. PB07 Model loop gain] [Pr. PB08 Position loop gain] [Pr. PB09 Speed loop gain] [Pr. PB10 Speed integral compensation]																					
___ 3	Manual mode																						
___ 4	2 gain adjustment mode 2	[Pr. PB08 Position loop gain] [Pr. PB09 Speed loop gain] [Pr. PB10 Speed integral compensation]																					

5. PARAMETERS

No.	Symbol	Name and function	Initial value [unit]	Setting range	Each/ Common																																																																																												
PA09	RSP	Auto tuning response Set a response of the auto tuning. <table border="1" data-bbox="347 405 1155 1182" style="width: 100%; border-collapse: collapse;"> <thead> <tr> <th rowspan="2">Setting value</th> <th colspan="2">Machine characteristic</th> <th rowspan="2">Setting value</th> <th colspan="2">Machine characteristic</th> </tr> <tr> <th>Response</th> <th>Guideline for machine resonance frequency [Hz]</th> <th>Response</th> <th>Guideline for machine resonance frequency [Hz]</th> </tr> </thead> <tbody> <tr> <td>1</td> <td rowspan="18" style="text-align: center; vertical-align: middle;"> Low response ↑ ↓ Middle response </td> <td>2.7</td> <td>21</td> <td rowspan="18" style="text-align: center; vertical-align: middle;"> Middle response ↑ ↓ High response </td> <td>67.1</td> </tr> <tr><td>2</td><td>3.6</td><td>22</td><td>75.6</td></tr> <tr><td>3</td><td>4.9</td><td>23</td><td>85.2</td></tr> <tr><td>4</td><td>6.6</td><td>24</td><td>95.9</td></tr> <tr><td>5</td><td>10.0</td><td>25</td><td>108.0</td></tr> <tr><td>6</td><td>11.3</td><td>26</td><td>121.7</td></tr> <tr><td>7</td><td>12.7</td><td>27</td><td>137.1</td></tr> <tr><td>8</td><td>14.3</td><td>28</td><td>154.4</td></tr> <tr><td>9</td><td>16.1</td><td>29</td><td>173.9</td></tr> <tr><td>10</td><td>18.1</td><td>30</td><td>195.9</td></tr> <tr><td>11</td><td>20.4</td><td>31</td><td>220.6</td></tr> <tr><td>12</td><td>23.0</td><td>32</td><td>248.5</td></tr> <tr><td>13</td><td>25.9</td><td>33</td><td>279.9</td></tr> <tr><td>14</td><td>29.2</td><td>34</td><td>315.3</td></tr> <tr><td>15</td><td>32.9</td><td>35</td><td>355.1</td></tr> <tr><td>16</td><td>37.0</td><td>36</td><td>400.0</td></tr> <tr><td>17</td><td>41.7</td><td>37</td><td>446.6</td></tr> <tr><td>18</td><td>47.0</td><td>38</td><td>501.2</td></tr> <tr><td>19</td><td>52.9</td><td>39</td><td>571.5</td></tr> <tr><td>20</td><td>59.6</td><td>40</td><td>642.7</td></tr> </tbody> </table>	Setting value	Machine characteristic		Setting value	Machine characteristic		Response	Guideline for machine resonance frequency [Hz]	Response	Guideline for machine resonance frequency [Hz]	1	Low response ↑ ↓ Middle response	2.7	21	Middle response ↑ ↓ High response	67.1	2	3.6	22	75.6	3	4.9	23	85.2	4	6.6	24	95.9	5	10.0	25	108.0	6	11.3	26	121.7	7	12.7	27	137.1	8	14.3	28	154.4	9	16.1	29	173.9	10	18.1	30	195.9	11	20.4	31	220.6	12	23.0	32	248.5	13	25.9	33	279.9	14	29.2	34	315.3	15	32.9	35	355.1	16	37.0	36	400.0	17	41.7	37	446.6	18	47.0	38	501.2	19	52.9	39	571.5	20	59.6	40	642.7	16	1 to 40	Each
Setting value	Machine characteristic			Setting value	Machine characteristic																																																																																												
	Response	Guideline for machine resonance frequency [Hz]	Response		Guideline for machine resonance frequency [Hz]																																																																																												
1	Low response ↑ ↓ Middle response	2.7	21	Middle response ↑ ↓ High response	67.1																																																																																												
2		3.6	22		75.6																																																																																												
3		4.9	23		85.2																																																																																												
4		6.6	24		95.9																																																																																												
5		10.0	25		108.0																																																																																												
6		11.3	26		121.7																																																																																												
7		12.7	27		137.1																																																																																												
8		14.3	28		154.4																																																																																												
9		16.1	29		173.9																																																																																												
10		18.1	30		195.9																																																																																												
11		20.4	31		220.6																																																																																												
12		23.0	32		248.5																																																																																												
13		25.9	33		279.9																																																																																												
14		29.2	34		315.3																																																																																												
15		32.9	35		355.1																																																																																												
16		37.0	36		400.0																																																																																												
17		41.7	37		446.6																																																																																												
18		47.0	38		501.2																																																																																												
19	52.9	39	571.5																																																																																														
20	59.6	40	642.7																																																																																														
PA10	INP	In-position range Set an in-position range per command pulse.	1600 [pulse]	0 to 65535	Each																																																																																												

5. PARAMETERS

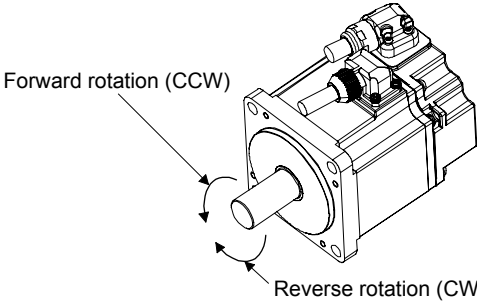
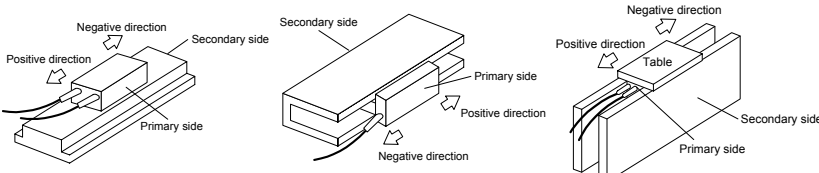
No.	Symbol	Name and function	Initial value [unit]	Setting range	Each/ Common											
PA14	*POL	<p>Rotation direction selection/travel direction selection This is used to select a rotation direction or travel direction.</p> <table border="1"> <thead> <tr> <th rowspan="2">Setting value</th> <th colspan="2">Servo motor rotation direction/linear servo motor travel direction</th> </tr> <tr> <th>Positioning address increase</th> <th>Positioning address decrease</th> </tr> </thead> <tbody> <tr> <td>0</td> <td>CCW or positive direction</td> <td>CW or negative direction</td> </tr> <tr> <td>1</td> <td>CW or negative direction</td> <td>CCW or positive direction</td> </tr> </tbody> </table> <p>The following shows the servo motor rotation directions.</p>  <p>The positive/negative directions of the linear servo motor are as follows.</p>  <p style="text-align: center;">LM-H3 series LM-U2 series LM-K2 series</p>	Setting value	Servo motor rotation direction/linear servo motor travel direction		Positioning address increase	Positioning address decrease	0	CCW or positive direction	CW or negative direction	1	CW or negative direction	CCW or positive direction	0	0 to 1	Each
Setting value	Servo motor rotation direction/linear servo motor travel direction															
	Positioning address increase	Positioning address decrease														
0	CCW or positive direction	CW or negative direction														
1	CW or negative direction	CCW or positive direction														
PA15	*ENR	<p>Encoder output pulses Set the encoder output pulses from the servo amplifier by using the number of output pulses per revolution, dividing ratio, or electronic gear ratio. (after multiplication by 4) To set a numerator of the electronic gear, select "A-phase/B-phase pulse electronic gear setting (_ _ 3 _)" of "Encoder output pulse setting selection" in [Pr. PC03]. The maximum output frequency is 4.6 Mpps. Set the parameter within this range.</p>	4000 [pulse/rev]	1 to 65535	Each											
PA16	*ENR2	<p>Encoder output pulses 2 Set a denominator of the electronic gear for the A/B-phase pulse output. To set a denominator of the electronic gear, select "A-phase/B-phase pulse electronic gear setting (_ _ 3 _)" of "Encoder output pulse setting selection" in [Pr. PC03].</p>	1	1 to 65535	Each											

5. PARAMETERS

No.	Symbol	Name and function	Initial value [unit]	Setting range	Each/ Common																																																														
PA17	**MSR	<p>Servo motor series setting</p> <p>When you use a linear servo motor, select its model from [Pr. PA17] and [Pr. PA18]. Set this and [Pr. PA18] at a time.</p> <p>Refer to the following table for settings.</p> <table border="1" style="width: 100%; border-collapse: collapse;"> <thead> <tr> <th rowspan="2">Linear servo motor series</th> <th rowspan="2">Servo motor model (primary side)</th> <th colspan="2">Parameter</th> </tr> <tr> <th>[Pr. PA17] setting</th> <th>[Pr. PA18] setting</th> </tr> </thead> <tbody> <tr> <td rowspan="9">LM-H3</td> <td>LM-H3P2A-07P-BSS0</td> <td rowspan="9">00BBh</td> <td>2101h</td> </tr> <tr> <td>LM-H3P3A-12P-CSS0</td> <td>3101h</td> </tr> <tr> <td>LM-H3P3B-24P-CSS0</td> <td>3201h</td> </tr> <tr> <td>LM-H3P3C-36P-CSS0</td> <td>3301h</td> </tr> <tr> <td>LM-H3P3D-48P-CSS0</td> <td>3401h</td> </tr> <tr> <td>LM-H3P7A-24P-ASS0</td> <td>7101h</td> </tr> <tr> <td>LM-H3P7B-48P-ASS0</td> <td>7201h</td> </tr> <tr> <td>LM-H3P7C-72P-ASS0</td> <td>7301h</td> </tr> <tr> <td>LM-H3P7D-96P-ASS0</td> <td>7401h</td> </tr> <tr> <td rowspan="9">LM-U2</td> <td>LM-U2PAB-05M-0SS0</td> <td rowspan="9">00B4h</td> <td>A201h</td> </tr> <tr> <td>LM-U2PAD-10M-0SS0</td> <td>A401h</td> </tr> <tr> <td>LM-U2PAF-15M-0SS0</td> <td>A601h</td> </tr> <tr> <td>LM-U2PBB-07M-1SS0</td> <td>B201h</td> </tr> <tr> <td>LM-U2PBD-15M-1SS0</td> <td>B401h</td> </tr> <tr> <td>LM-U2PBF-22M-1SS0</td> <td>2601h</td> </tr> <tr> <td>LM-U2P2B-40M-2SS0</td> <td>2201h</td> </tr> <tr> <td>LM-U2P2C-60M-2SS0</td> <td>2301h</td> </tr> <tr> <td>LM-U2P2D-80M-2SS0</td> <td>2401h</td> </tr> <tr> <td rowspan="7">LM-K2</td> <td>LM-K2P1A-01M-2SS1</td> <td rowspan="7">00B8h</td> <td>1101h</td> </tr> <tr> <td>LM-K2P1C-03M-2SS1</td> <td>1301h</td> </tr> <tr> <td>LM-K2P2A-02M-1SS1</td> <td>2101h</td> </tr> <tr> <td>LM-K2P2C-07M-1SS1</td> <td>2301h</td> </tr> <tr> <td>LM-K2P2E-12M-1SS1</td> <td>2501h</td> </tr> <tr> <td>LM-K2P3C-14M-1SS1</td> <td>3301h</td> </tr> <tr> <td>LM-K2P3E-24M-1SS1</td> <td>3501h</td> </tr> </tbody> </table>	Linear servo motor series	Servo motor model (primary side)	Parameter		[Pr. PA17] setting	[Pr. PA18] setting	LM-H3	LM-H3P2A-07P-BSS0	00BBh	2101h	LM-H3P3A-12P-CSS0	3101h	LM-H3P3B-24P-CSS0	3201h	LM-H3P3C-36P-CSS0	3301h	LM-H3P3D-48P-CSS0	3401h	LM-H3P7A-24P-ASS0	7101h	LM-H3P7B-48P-ASS0	7201h	LM-H3P7C-72P-ASS0	7301h	LM-H3P7D-96P-ASS0	7401h	LM-U2	LM-U2PAB-05M-0SS0	00B4h	A201h	LM-U2PAD-10M-0SS0	A401h	LM-U2PAF-15M-0SS0	A601h	LM-U2PBB-07M-1SS0	B201h	LM-U2PBD-15M-1SS0	B401h	LM-U2PBF-22M-1SS0	2601h	LM-U2P2B-40M-2SS0	2201h	LM-U2P2C-60M-2SS0	2301h	LM-U2P2D-80M-2SS0	2401h	LM-K2	LM-K2P1A-01M-2SS1	00B8h	1101h	LM-K2P1C-03M-2SS1	1301h	LM-K2P2A-02M-1SS1	2101h	LM-K2P2C-07M-1SS1	2301h	LM-K2P2E-12M-1SS1	2501h	LM-K2P3C-14M-1SS1	3301h	LM-K2P3E-24M-1SS1	3501h	0000h	Refer to Name and function column.	Each
Linear servo motor series	Servo motor model (primary side)	Parameter																																																																	
		[Pr. PA17] setting	[Pr. PA18] setting																																																																
LM-H3	LM-H3P2A-07P-BSS0	00BBh	2101h																																																																
	LM-H3P3A-12P-CSS0		3101h																																																																
	LM-H3P3B-24P-CSS0		3201h																																																																
	LM-H3P3C-36P-CSS0		3301h																																																																
	LM-H3P3D-48P-CSS0		3401h																																																																
	LM-H3P7A-24P-ASS0		7101h																																																																
	LM-H3P7B-48P-ASS0		7201h																																																																
	LM-H3P7C-72P-ASS0		7301h																																																																
	LM-H3P7D-96P-ASS0		7401h																																																																
LM-U2	LM-U2PAB-05M-0SS0	00B4h	A201h																																																																
	LM-U2PAD-10M-0SS0		A401h																																																																
	LM-U2PAF-15M-0SS0		A601h																																																																
	LM-U2PBB-07M-1SS0		B201h																																																																
	LM-U2PBD-15M-1SS0		B401h																																																																
	LM-U2PBF-22M-1SS0		2601h																																																																
	LM-U2P2B-40M-2SS0		2201h																																																																
	LM-U2P2C-60M-2SS0		2301h																																																																
	LM-U2P2D-80M-2SS0		2401h																																																																
LM-K2	LM-K2P1A-01M-2SS1	00B8h	1101h																																																																
	LM-K2P1C-03M-2SS1		1301h																																																																
	LM-K2P2A-02M-1SS1		2101h																																																																
	LM-K2P2C-07M-1SS1		2301h																																																																
	LM-K2P2E-12M-1SS1		2501h																																																																
	LM-K2P3C-14M-1SS1		3301h																																																																
	LM-K2P3E-24M-1SS1		3501h																																																																
PA18	**MTY	<p>Servo motor type setting</p> <p>When you use a linear servo motor, select its model from [Pr. PA17] and [Pr. PA18]. Set this and [Pr. PA17] at a time.</p> <p>Refer to the table of [Pr. PA17] for settings.</p>	0000h	Refer to Name and function column of [Pr. PA17].	Each																																																														

5. PARAMETERS

No.	Symbol	Name and function	Initial value [unit]	Setting range	Each/ Common																																																																																																																																																																																																																					
PA19	*BLK	Parameter writing inhibit Select a reference range and writing range of the parameter. Refer to table 5.3 for settings.	00ABh	Refer to Name and function column.	Each																																																																																																																																																																																																																					
Table 5.3 [Pr. PA19] setting value and reading/writing range																																																																																																																																																																																																																										
		<table border="1"> <thead> <tr> <th>PA19</th> <th>Setting operation</th> <th>PA</th> <th>PB</th> <th>PC</th> <th>PD</th> <th>PE</th> <th>PF</th> <th>PL</th> </tr> </thead> <tbody> <tr> <td rowspan="2">Other than below</td> <td>Reading</td> <td style="text-align: center;">○</td> <td style="text-align: center;">/</td> <td style="text-align: center;">/</td> <td style="text-align: center;">/</td> <td style="text-align: center;">/</td> <td style="text-align: center;">/</td> <td style="text-align: center;">/</td> </tr> <tr> <td>Writing</td> <td style="text-align: center;">○</td> <td style="text-align: center;">/</td> <td style="text-align: center;">/</td> <td style="text-align: center;">/</td> <td style="text-align: center;">/</td> <td style="text-align: center;">/</td> <td style="text-align: center;">/</td> </tr> <tr> <td rowspan="2">000Ah</td> <td>Reading</td> <td>Only 19</td> <td style="text-align: center;">/</td> <td style="text-align: center;">/</td> <td style="text-align: center;">/</td> <td style="text-align: center;">/</td> <td style="text-align: center;">/</td> <td style="text-align: center;">/</td> </tr> <tr> <td>Writing</td> <td>Only 19</td> <td style="text-align: center;">/</td> <td style="text-align: center;">/</td> <td style="text-align: center;">/</td> <td style="text-align: center;">/</td> <td style="text-align: center;">/</td> <td style="text-align: center;">/</td> </tr> <tr> <td rowspan="2">000Bh</td> <td>Reading</td> <td style="text-align: center;">○</td> <td style="text-align: center;">○</td> <td style="text-align: center;">○</td> <td style="text-align: center;">/</td> <td style="text-align: center;">/</td> <td style="text-align: center;">/</td> <td style="text-align: center;">/</td> </tr> <tr> <td>Writing</td> <td style="text-align: center;">○</td> <td style="text-align: center;">○</td> <td style="text-align: center;">○</td> <td style="text-align: center;">/</td> <td style="text-align: center;">/</td> <td style="text-align: center;">/</td> <td style="text-align: center;">/</td> </tr> <tr> <td rowspan="2">000Ch</td> <td>Reading</td> <td style="text-align: center;">○</td> <td style="text-align: center;">○</td> <td style="text-align: center;">○</td> <td style="text-align: center;">○</td> <td style="text-align: center;">/</td> <td style="text-align: center;">/</td> <td style="text-align: center;">/</td> </tr> <tr> <td>Writing</td> <td style="text-align: center;">○</td> <td style="text-align: center;">○</td> <td style="text-align: center;">○</td> <td style="text-align: center;">○</td> <td style="text-align: center;">/</td> <td style="text-align: center;">/</td> <td style="text-align: center;">/</td> </tr> <tr> <td rowspan="2">000Fh</td> <td>Reading</td> <td style="text-align: center;">○</td> <td style="text-align: center;">○</td> <td style="text-align: center;">○</td> <td style="text-align: center;">○</td> <td style="text-align: center;">○</td> <td style="text-align: center;">/</td> <td style="text-align: center;">○</td> </tr> <tr> <td>Writing</td> <td style="text-align: center;">○</td> <td style="text-align: center;">○</td> <td style="text-align: center;">○</td> <td style="text-align: center;">○</td> <td style="text-align: center;">○</td> <td style="text-align: center;">/</td> <td style="text-align: center;">○</td> </tr> <tr> <td rowspan="2">00AAh</td> <td>Reading</td> <td style="text-align: center;">○</td> <td style="text-align: center;">○</td> <td style="text-align: center;">○</td> <td style="text-align: center;">○</td> <td style="text-align: center;">○</td> <td style="text-align: center;">○</td> <td style="text-align: center;">/</td> </tr> <tr> <td>Writing</td> <td style="text-align: center;">○</td> <td style="text-align: center;">○</td> <td style="text-align: center;">○</td> <td style="text-align: center;">○</td> <td style="text-align: center;">○</td> <td style="text-align: center;">○</td> <td style="text-align: center;">/</td> </tr> <tr> <td rowspan="2">00ABh (initial value)</td> <td>Reading</td> <td style="text-align: center;">○</td> <td style="text-align: center;">○</td> <td style="text-align: center;">○</td> <td style="text-align: center;">○</td> <td style="text-align: center;">○</td> <td style="text-align: center;">○</td> <td style="text-align: center;">○</td> </tr> <tr> <td>Writing</td> <td style="text-align: center;">○</td> <td style="text-align: center;">○</td> <td style="text-align: center;">○</td> <td style="text-align: center;">○</td> <td style="text-align: center;">○</td> <td style="text-align: center;">○</td> <td style="text-align: center;">○</td> </tr> <tr> <td rowspan="2">100Bh</td> <td>Reading</td> <td style="text-align: center;">○</td> <td style="text-align: center;">/</td> <td style="text-align: center;">/</td> <td style="text-align: center;">/</td> <td style="text-align: center;">/</td> <td style="text-align: center;">/</td> <td style="text-align: center;">/</td> </tr> <tr> <td>Writing</td> <td>Only 19</td> <td style="text-align: center;">/</td> <td style="text-align: center;">/</td> <td style="text-align: center;">/</td> <td style="text-align: center;">/</td> <td style="text-align: center;">/</td> <td style="text-align: center;">/</td> </tr> <tr> <td rowspan="2">100Ch</td> <td>Reading</td> <td style="text-align: center;">○</td> <td style="text-align: center;">○</td> <td style="text-align: center;">○</td> <td style="text-align: center;">○</td> <td style="text-align: center;">/</td> <td style="text-align: center;">/</td> <td style="text-align: center;">/</td> </tr> <tr> <td>Writing</td> <td>Only 19</td> <td style="text-align: center;">/</td> <td style="text-align: center;">/</td> <td style="text-align: center;">/</td> <td style="text-align: center;">/</td> <td style="text-align: center;">/</td> <td style="text-align: center;">/</td> </tr> <tr> <td rowspan="2">100Fh</td> <td>Reading</td> <td style="text-align: center;">○</td> <td style="text-align: center;">○</td> <td style="text-align: center;">○</td> <td style="text-align: center;">○</td> <td style="text-align: center;">○</td> <td style="text-align: center;">/</td> <td style="text-align: center;">○</td> </tr> <tr> <td>Writing</td> <td>Only 19</td> <td style="text-align: center;">/</td> <td style="text-align: center;">/</td> <td style="text-align: center;">/</td> <td style="text-align: center;">/</td> <td style="text-align: center;">/</td> <td style="text-align: center;">/</td> </tr> <tr> <td rowspan="2">10AAh</td> <td>Reading</td> <td style="text-align: center;">○</td> <td style="text-align: center;">○</td> <td style="text-align: center;">○</td> <td style="text-align: center;">○</td> <td style="text-align: center;">○</td> <td style="text-align: center;">○</td> <td style="text-align: center;">/</td> </tr> <tr> <td>Writing</td> <td>Only 19</td> <td style="text-align: center;">/</td> <td style="text-align: center;">/</td> <td style="text-align: center;">/</td> <td style="text-align: center;">/</td> <td style="text-align: center;">/</td> <td style="text-align: center;">/</td> </tr> <tr> <td rowspan="2">10ABh</td> <td>Reading</td> <td style="text-align: center;">○</td> <td style="text-align: center;">○</td> <td style="text-align: center;">○</td> <td style="text-align: center;">○</td> <td style="text-align: center;">○</td> <td style="text-align: center;">○</td> <td style="text-align: center;">○</td> </tr> <tr> <td>Writing</td> <td>Only 19</td> <td style="text-align: center;">/</td> <td style="text-align: center;">/</td> <td style="text-align: center;">/</td> <td style="text-align: center;">/</td> <td style="text-align: center;">/</td> <td style="text-align: center;">/</td> </tr> </tbody> </table>	PA19	Setting operation	PA	PB	PC	PD	PE	PF	PL	Other than below	Reading	○	/	/	/	/	/	/	Writing	○	/	/	/	/	/	/	000Ah	Reading	Only 19	/	/	/	/	/	/	Writing	Only 19	/	/	/	/	/	/	000Bh	Reading	○	○	○	/	/	/	/	Writing	○	○	○	/	/	/	/	000Ch	Reading	○	○	○	○	/	/	/	Writing	○	○	○	○	/	/	/	000Fh	Reading	○	○	○	○	○	/	○	Writing	○	○	○	○	○	/	○	00AAh	Reading	○	○	○	○	○	○	/	Writing	○	○	○	○	○	○	/	00ABh (initial value)	Reading	○	○	○	○	○	○	○	Writing	○	○	○	○	○	○	○	100Bh	Reading	○	/	/	/	/	/	/	Writing	Only 19	/	/	/	/	/	/	100Ch	Reading	○	○	○	○	/	/	/	Writing	Only 19	/	/	/	/	/	/	100Fh	Reading	○	○	○	○	○	/	○	Writing	Only 19	/	/	/	/	/	/	10AAh	Reading	○	○	○	○	○	○	/	Writing	Only 19	/	/	/	/	/	/	10ABh	Reading	○	○	○	○	○	○	○	Writing	Only 19	/	/	/	/	/	/			
PA19	Setting operation	PA	PB	PC	PD	PE	PF	PL																																																																																																																																																																																																																		
Other than below	Reading	○	/	/	/	/	/	/																																																																																																																																																																																																																		
	Writing	○	/	/	/	/	/	/																																																																																																																																																																																																																		
000Ah	Reading	Only 19	/	/	/	/	/	/																																																																																																																																																																																																																		
	Writing	Only 19	/	/	/	/	/	/																																																																																																																																																																																																																		
000Bh	Reading	○	○	○	/	/	/	/																																																																																																																																																																																																																		
	Writing	○	○	○	/	/	/	/																																																																																																																																																																																																																		
000Ch	Reading	○	○	○	○	/	/	/																																																																																																																																																																																																																		
	Writing	○	○	○	○	/	/	/																																																																																																																																																																																																																		
000Fh	Reading	○	○	○	○	○	/	○																																																																																																																																																																																																																		
	Writing	○	○	○	○	○	/	○																																																																																																																																																																																																																		
00AAh	Reading	○	○	○	○	○	○	/																																																																																																																																																																																																																		
	Writing	○	○	○	○	○	○	/																																																																																																																																																																																																																		
00ABh (initial value)	Reading	○	○	○	○	○	○	○																																																																																																																																																																																																																		
	Writing	○	○	○	○	○	○	○																																																																																																																																																																																																																		
100Bh	Reading	○	/	/	/	/	/	/																																																																																																																																																																																																																		
	Writing	Only 19	/	/	/	/	/	/																																																																																																																																																																																																																		
100Ch	Reading	○	○	○	○	/	/	/																																																																																																																																																																																																																		
	Writing	Only 19	/	/	/	/	/	/																																																																																																																																																																																																																		
100Fh	Reading	○	○	○	○	○	/	○																																																																																																																																																																																																																		
	Writing	Only 19	/	/	/	/	/	/																																																																																																																																																																																																																		
10AAh	Reading	○	○	○	○	○	○	/																																																																																																																																																																																																																		
	Writing	Only 19	/	/	/	/	/	/																																																																																																																																																																																																																		
10ABh	Reading	○	○	○	○	○	○	○																																																																																																																																																																																																																		
	Writing	Only 19	/	/	/	/	/	/																																																																																																																																																																																																																		

5. PARAMETERS

No.	Symbol	Name and function	Initial value [unit]	Setting range	Each/ Common															
PA20	*TDS	<p>Tough drive setting</p> <p>Alarms may not be avoided with the tough drive function depending on the situations of the power supply and load fluctuation.</p> <p>You can assign MTTR (During tough drive) to pins CN3-11 to CN3-13, CN3-24, and CN3-25 with [Pr. PD07] to [Pr. PD09].</p> <table border="1"> <thead> <tr> <th>Setting digit</th> <th>Explanation</th> <th>Initial value</th> </tr> </thead> <tbody> <tr> <td>___ x</td> <td>For manufacturer setting</td> <td>0h</td> </tr> <tr> <td>__ x _</td> <td>Vibration tough drive selection 0: Disabled 1: Enabled Selecting "1" enables to suppress vibrations by automatically changing setting values of [Pr. PB13 Machine resonance suppression filter 1] and [Pr. PB15 Machine resonance suppression filter 2] in case that the vibration exceed the value of the oscillation level set in [Pr. PF23]. Refer to section 7.3 for details.</td> <td>0h</td> </tr> <tr> <td>_ x _ _</td> <td>SEMI-F47 function selection (instantaneous power failure tough drive selection) 0: Disabled 1: Enabled Selecting "1" enables to avoid generating [AL. 10.1 Voltage drop in the control circuit power] using the electrical energy charged in the capacitor in case that an instantaneous power failure occurs during operation. Set the time of until [AL. 10.1 Voltage drop in the control circuit power] occurs in [Pr. PF25 SEMI-F47 function - Instantaneous power failure detection time (instantaneous power failure tough drive - detection time)]. A specified axis cannot be enabled for the instantaneous power failure tough drive function.</td> <td>0h</td> </tr> <tr> <td>x _ _ _</td> <td>For manufacturer setting</td> <td>0h</td> </tr> </tbody> </table>	Setting digit	Explanation	Initial value	___ x	For manufacturer setting	0h	__ x _	Vibration tough drive selection 0: Disabled 1: Enabled Selecting "1" enables to suppress vibrations by automatically changing setting values of [Pr. PB13 Machine resonance suppression filter 1] and [Pr. PB15 Machine resonance suppression filter 2] in case that the vibration exceed the value of the oscillation level set in [Pr. PF23]. Refer to section 7.3 for details.	0h	_ x _ _	SEMI-F47 function selection (instantaneous power failure tough drive selection) 0: Disabled 1: Enabled Selecting "1" enables to avoid generating [AL. 10.1 Voltage drop in the control circuit power] using the electrical energy charged in the capacitor in case that an instantaneous power failure occurs during operation. Set the time of until [AL. 10.1 Voltage drop in the control circuit power] occurs in [Pr. PF25 SEMI-F47 function - Instantaneous power failure detection time (instantaneous power failure tough drive - detection time)]. A specified axis cannot be enabled for the instantaneous power failure tough drive function.	0h	x _ _ _	For manufacturer setting	0h	Refer to Name and function column.		Each
Setting digit	Explanation	Initial value																		
___ x	For manufacturer setting	0h																		
__ x _	Vibration tough drive selection 0: Disabled 1: Enabled Selecting "1" enables to suppress vibrations by automatically changing setting values of [Pr. PB13 Machine resonance suppression filter 1] and [Pr. PB15 Machine resonance suppression filter 2] in case that the vibration exceed the value of the oscillation level set in [Pr. PF23]. Refer to section 7.3 for details.	0h																		
_ x _ _	SEMI-F47 function selection (instantaneous power failure tough drive selection) 0: Disabled 1: Enabled Selecting "1" enables to avoid generating [AL. 10.1 Voltage drop in the control circuit power] using the electrical energy charged in the capacitor in case that an instantaneous power failure occurs during operation. Set the time of until [AL. 10.1 Voltage drop in the control circuit power] occurs in [Pr. PF25 SEMI-F47 function - Instantaneous power failure detection time (instantaneous power failure tough drive - detection time)]. A specified axis cannot be enabled for the instantaneous power failure tough drive function.	0h																		
x _ _ _	For manufacturer setting	0h																		
PA21	*AOP3	<p>Function selection A-3</p> <table border="1"> <thead> <tr> <th>Setting digit</th> <th>Explanation</th> <th>Initial value</th> </tr> </thead> <tbody> <tr> <td>___ x</td> <td>One-touch tuning function selection 0: Disabled 1: Enabled When the digit is "0", the one-touch tuning with MR Configurator2 will be disabled.</td> <td>1h</td> </tr> <tr> <td>__ x _</td> <td>For manufacturer setting</td> <td>0h</td> </tr> <tr> <td>_ x _ _</td> <td></td> <td>0h</td> </tr> <tr> <td>x _ _ _</td> <td></td> <td>0h</td> </tr> </tbody> </table>	Setting digit	Explanation	Initial value	___ x	One-touch tuning function selection 0: Disabled 1: Enabled When the digit is "0", the one-touch tuning with MR Configurator2 will be disabled.	1h	__ x _	For manufacturer setting	0h	_ x _ _		0h	x _ _ _		0h	Refer to Name and function column.		Each
Setting digit	Explanation	Initial value																		
___ x	One-touch tuning function selection 0: Disabled 1: Enabled When the digit is "0", the one-touch tuning with MR Configurator2 will be disabled.	1h																		
__ x _	For manufacturer setting	0h																		
_ x _ _		0h																		
x _ _ _		0h																		

5. PARAMETERS

No.	Symbol	Name and function	Initial value [unit]	Setting range	Each/ Common													
PA23	DRAT	Drive recorder arbitrary alarm trigger setting <table border="1"> <thead> <tr> <th>Setting digit</th> <th>Explanation</th> <th>Initial value</th> </tr> </thead> <tbody> <tr> <td>__ x x</td> <td>Alarm detail No. setting Set the digits when you execute the trigger with arbitrary alarm detail No. for the drive recorder function. When these digits are "0 0", the drive recorder will operate with any alarm No. regardless of detail numbers.</td> <td>00h</td> </tr> <tr> <td>x x __</td> <td>Alarm No. setting Set the digits when you execute the trigger with arbitrary alarm No. for the drive recorder function. When "0 0" are set, arbitrary alarm trigger of the drive recorder will be disabled.</td> <td>00h</td> </tr> </tbody> </table> Setting example: To activate the drive recorder when [AL. 50 Overload 1] occurs, set "5 0 0 0". To activate the drive recorder when [AL. 50.3 Thermal overload error 4 during operation] occurs, set "5 0 0 3".	Setting digit	Explanation	Initial value	__ x x	Alarm detail No. setting Set the digits when you execute the trigger with arbitrary alarm detail No. for the drive recorder function. When these digits are "0 0", the drive recorder will operate with any alarm No. regardless of detail numbers.	00h	x x __	Alarm No. setting Set the digits when you execute the trigger with arbitrary alarm No. for the drive recorder function. When "0 0" are set, arbitrary alarm trigger of the drive recorder will be disabled.	00h	Refer to Name and function column.		Common				
Setting digit	Explanation	Initial value																
__ x x	Alarm detail No. setting Set the digits when you execute the trigger with arbitrary alarm detail No. for the drive recorder function. When these digits are "0 0", the drive recorder will operate with any alarm No. regardless of detail numbers.	00h																
x x __	Alarm No. setting Set the digits when you execute the trigger with arbitrary alarm No. for the drive recorder function. When "0 0" are set, arbitrary alarm trigger of the drive recorder will be disabled.	00h																
PA24	AOP4	Function selection A-4 <table border="1"> <thead> <tr> <th>Setting digit</th> <th>Explanation</th> <th>Initial value</th> </tr> </thead> <tbody> <tr> <td>___ x</td> <td>Vibration suppression mode selection 0: Standard mode 1: 3 inertia mode 2: Low response mode When two low resonance frequencies are generated, select "3 inertia mode (___ 1)". When the load to motor inertia ratio exceeds the recommended load to motor inertia ratio select "Low response mode (___ 2)". When you select the standard mode or low response mode, "Vibration suppression control 2" is not available. When you select the 3 inertia mode, the feed forward gain is not available. Before changing the control mode with the controller during the 3 inertia mode or low response mode, stop the motor.</td> <td>0h</td> </tr> <tr> <td>__ x _</td> <td rowspan="3">For manufacturer setting</td> <td>0h</td> </tr> <tr> <td>_ x _ _</td> <td>0h</td> </tr> <tr> <td>x _ _ _</td> <td>0h</td> </tr> </tbody> </table>	Setting digit	Explanation	Initial value	___ x	Vibration suppression mode selection 0: Standard mode 1: 3 inertia mode 2: Low response mode When two low resonance frequencies are generated, select "3 inertia mode (___ 1)". When the load to motor inertia ratio exceeds the recommended load to motor inertia ratio select "Low response mode (___ 2)". When you select the standard mode or low response mode, "Vibration suppression control 2" is not available. When you select the 3 inertia mode, the feed forward gain is not available. Before changing the control mode with the controller during the 3 inertia mode or low response mode, stop the motor.	0h	__ x _	For manufacturer setting	0h	_ x _ _	0h	x _ _ _	0h	Refer to Name and function column.		Each
Setting digit	Explanation	Initial value																
___ x	Vibration suppression mode selection 0: Standard mode 1: 3 inertia mode 2: Low response mode When two low resonance frequencies are generated, select "3 inertia mode (___ 1)". When the load to motor inertia ratio exceeds the recommended load to motor inertia ratio select "Low response mode (___ 2)". When you select the standard mode or low response mode, "Vibration suppression control 2" is not available. When you select the 3 inertia mode, the feed forward gain is not available. Before changing the control mode with the controller during the 3 inertia mode or low response mode, stop the motor.	0h																
__ x _	For manufacturer setting	0h																
_ x _ _		0h																
x _ _ _		0h																
PA25	OTHOV	One-touch tuning - Overshoot permissible level This is used to set a permissible value of overshoot amount with a percentage to in-position range. However, setting "0" will be 50%.	0 [%]	0 to 100	Each													

5. PARAMETERS

5.2.2 Gain/filter setting parameters ([Pr. PB_ _])

No.	Symbol	Name and function	Initial value [unit]	Setting range	Each/ Common														
PB01	FILT	<p>Adaptive tuning mode (adaptive filter II) Set the adaptive filter tuning. All axes cannot be simultaneously enabled for this function. Set for each axis to use.</p> <table border="1"> <thead> <tr> <th>Setting digit</th> <th>Explanation</th> <th>Initial value</th> </tr> </thead> <tbody> <tr> <td>___x</td> <td>Filter tuning mode selection Select the adjustment mode of the machine resonance suppression filter 1. Refer to section 7.1.2 for details. 0: Disabled 1: Automatic setting 2: Manual setting</td> <td>0h</td> </tr> <tr> <td>__x_</td> <td rowspan="3">For manufacturer setting</td> <td>0h</td> </tr> <tr> <td>_x__</td> <td>0h</td> </tr> <tr> <td>x___</td> <td>0h</td> </tr> </tbody> </table>	Setting digit	Explanation	Initial value	___x	Filter tuning mode selection Select the adjustment mode of the machine resonance suppression filter 1. Refer to section 7.1.2 for details. 0: Disabled 1: Automatic setting 2: Manual setting	0h	__x_	For manufacturer setting	0h	_x__	0h	x___	0h	Refer to Name and function column.		Each	
Setting digit	Explanation	Initial value																	
___x	Filter tuning mode selection Select the adjustment mode of the machine resonance suppression filter 1. Refer to section 7.1.2 for details. 0: Disabled 1: Automatic setting 2: Manual setting	0h																	
__x_	For manufacturer setting	0h																	
_x__		0h																	
x___		0h																	
PB02	VRFT	<p>Vibration suppression control tuning mode (advanced vibration suppression control II) This is used to set the vibration suppression control tuning. Refer to section 7.1.5 for details. All axes cannot be simultaneously enabled for this function. Set for each axis to use.</p> <table border="1"> <thead> <tr> <th>Setting digit</th> <th>Explanation</th> <th>Initial value</th> </tr> </thead> <tbody> <tr> <td>___x</td> <td>Vibration suppression control 1 tuning mode selection Select the tuning mode of the vibration suppression control 1. 0: Disabled 1: Automatic setting 2: Manual setting</td> <td>0h</td> </tr> <tr> <td>__x_</td> <td>Vibration suppression control 2 tuning mode selection Select the tuning mode of the vibration suppression control 2. To enable the digit, select "3 inertia mode (_ _ _ 1)" of "Vibration suppression mode selection" in [Pr. PA24 Function selection A-4]. 0: Disabled 1: Automatic setting 2: Manual setting</td> <td>0h</td> </tr> <tr> <td>_x__</td> <td rowspan="2">For manufacturer setting</td> <td>0h</td> </tr> <tr> <td>x___</td> <td>0h</td> </tr> </tbody> </table>	Setting digit	Explanation	Initial value	___x	Vibration suppression control 1 tuning mode selection Select the tuning mode of the vibration suppression control 1. 0: Disabled 1: Automatic setting 2: Manual setting	0h	__x_	Vibration suppression control 2 tuning mode selection Select the tuning mode of the vibration suppression control 2. To enable the digit, select "3 inertia mode (_ _ _ 1)" of "Vibration suppression mode selection" in [Pr. PA24 Function selection A-4]. 0: Disabled 1: Automatic setting 2: Manual setting	0h	_x__	For manufacturer setting	0h	x___	0h	Refer to Name and function column.		Each
Setting digit	Explanation	Initial value																	
___x	Vibration suppression control 1 tuning mode selection Select the tuning mode of the vibration suppression control 1. 0: Disabled 1: Automatic setting 2: Manual setting	0h																	
__x_	Vibration suppression control 2 tuning mode selection Select the tuning mode of the vibration suppression control 2. To enable the digit, select "3 inertia mode (_ _ _ 1)" of "Vibration suppression mode selection" in [Pr. PA24 Function selection A-4]. 0: Disabled 1: Automatic setting 2: Manual setting	0h																	
_x__	For manufacturer setting	0h																	
x___		0h																	
PB03	TFBGN	<p>Torque feedback loop gain This is used to set a torque feedback loop gain in the continuous operation to torque control mode. Decreasing the setting value will also decrease a collision load during continuous operation to torque control mode. Setting a value less than 6 rad/s will be 6 rad/s.</p>	18000 [rad/s]	0 to 18000	Each														
PB04	FFC	<p>Feed forward gain Set the feed forward gain. When the setting is 100%, the droop pulses during operation at constant speed are nearly zero. However, sudden acceleration/deceleration will increase the overshoot. As a guideline, when the feed forward gain setting is 100%, set 1 s or more as the acceleration time constant up to the rated speed.</p>	0 [%]	0 to 100	Each														

5. PARAMETERS

No.	Symbol	Name and function	Initial value [unit]	Setting range	Each/ Common										
PB06	GD2	<p>Load to motor inertia ratio/load to motor mass ratio</p> <p>This is used to set the load to motor inertia ratio or load to motor mass ratio.</p> <p>The setting of the parameter will be the automatic setting or manual setting depending on the [Pr. PA08] setting. Refer to the following table for details. When the parameter is automatic setting, the value will vary between 0.00 and 100.00.</p> <table border="1" data-bbox="347 488 1034 707"> <thead> <tr> <th>Pr. PA08</th> <th>This parameter</th> </tr> </thead> <tbody> <tr> <td>___ 0 (2 gain adjustment mode 1 (interpolation mode))</td> <td rowspan="2">Automatic setting</td> </tr> <tr> <td>___ 1 (Auto tuning mode 1)</td> </tr> <tr> <td>___ 2 (Auto tuning mode 2)</td> <td rowspan="3">Manual setting</td> </tr> <tr> <td>___ 3 (Manual mode)</td> </tr> <tr> <td>___ 4 (2 gain adjustment mode 2)</td> </tr> </tbody> </table>	Pr. PA08	This parameter	___ 0 (2 gain adjustment mode 1 (interpolation mode))	Automatic setting	___ 1 (Auto tuning mode 1)	___ 2 (Auto tuning mode 2)	Manual setting	___ 3 (Manual mode)	___ 4 (2 gain adjustment mode 2)	7.00 [Multiplier]	000 to 30000	Each	
Pr. PA08	This parameter														
___ 0 (2 gain adjustment mode 1 (interpolation mode))	Automatic setting														
___ 1 (Auto tuning mode 1)															
___ 2 (Auto tuning mode 2)	Manual setting														
___ 3 (Manual mode)															
___ 4 (2 gain adjustment mode 2)															
PB07	PG1	<p>Model loop gain</p> <p>Set the response gain up to the target position.</p> <p>Increasing the setting value will also increase the response level to the position command but will be liable to generate vibration and/or noise.</p> <p>The setting of the parameter will be the automatic setting or manual setting depending on the [Pr. PA08] setting. Refer to the following table for details.</p> <table border="1" data-bbox="347 931 1034 1151"> <thead> <tr> <th>Pr. PA08</th> <th>This parameter</th> </tr> </thead> <tbody> <tr> <td>___ 0 (2 gain adjustment mode 1 (interpolation mode))</td> <td rowspan="2">Automatic setting</td> </tr> <tr> <td>___ 1 (Auto tuning mode 1)</td> </tr> <tr> <td>___ 2 (Auto tuning mode 2)</td> <td rowspan="3">Manual setting</td> </tr> <tr> <td>___ 3 (Manual mode)</td> </tr> <tr> <td>___ 4 (2 gain adjustment mode 2)</td> <td>Automatic setting</td> </tr> </tbody> </table>	Pr. PA08	This parameter	___ 0 (2 gain adjustment mode 1 (interpolation mode))	Automatic setting	___ 1 (Auto tuning mode 1)	___ 2 (Auto tuning mode 2)	Manual setting	___ 3 (Manual mode)	___ 4 (2 gain adjustment mode 2)	Automatic setting	15.0 [rad/s]	10 to 20000	Each
Pr. PA08	This parameter														
___ 0 (2 gain adjustment mode 1 (interpolation mode))	Automatic setting														
___ 1 (Auto tuning mode 1)															
___ 2 (Auto tuning mode 2)	Manual setting														
___ 3 (Manual mode)															
___ 4 (2 gain adjustment mode 2)		Automatic setting													
PB08	PG2	<p>Position loop gain</p> <p>This is used to set the gain of the position loop.</p> <p>Set this parameter to increase the position response to level load disturbance.</p> <p>Increasing the setting value will also increase the response level to the load disturbance but will be liable to generate vibration and/or noise.</p> <p>The setting of the parameter will be the automatic setting or manual setting depending on the [Pr. PA08] setting. Refer to the following table for details.</p> <table border="1" data-bbox="347 1402 1034 1621"> <thead> <tr> <th>Pr. PA08</th> <th>This parameter</th> </tr> </thead> <tbody> <tr> <td>___ 0 (2 gain adjustment mode 1 (interpolation mode))</td> <td rowspan="2">Automatic setting</td> </tr> <tr> <td>___ 1 (Auto tuning mode 1)</td> </tr> <tr> <td>___ 2 (Auto tuning mode 2)</td> <td rowspan="3">Manual setting</td> </tr> <tr> <td>___ 3 (Manual mode)</td> </tr> <tr> <td>___ 4 (2 gain adjustment mode 2)</td> <td>Automatic setting</td> </tr> </tbody> </table>	Pr. PA08	This parameter	___ 0 (2 gain adjustment mode 1 (interpolation mode))	Automatic setting	___ 1 (Auto tuning mode 1)	___ 2 (Auto tuning mode 2)	Manual setting	___ 3 (Manual mode)	___ 4 (2 gain adjustment mode 2)	Automatic setting	37.0 [rad/s]	10 to 20000	Each
Pr. PA08	This parameter														
___ 0 (2 gain adjustment mode 1 (interpolation mode))	Automatic setting														
___ 1 (Auto tuning mode 1)															
___ 2 (Auto tuning mode 2)	Manual setting														
___ 3 (Manual mode)															
___ 4 (2 gain adjustment mode 2)		Automatic setting													
PB09	VG2	<p>Speed loop gain</p> <p>This is used to set the gain of the speed loop.</p> <p>Set this parameter when vibration occurs on machines of low rigidity or large backlash. Increasing the setting value will also increase the response level but will be liable to generate vibration and/or noise.</p> <p>The setting of the parameter will be the automatic setting or manual setting depending on the [Pr. PA08] setting. Refer to the table of [Pr. PB08] for details.</p>	823 [rad/s]	20 to 65535	Each										
PB10	VIC	<p>Speed integral compensation</p> <p>This is used to set the integral time constant of the speed loop.</p> <p>Decreasing the setting value will increase the response level but will be liable to generate vibration and/or noise.</p> <p>The setting of the parameter will be the automatic setting or manual setting depending on the [Pr. PA08] setting. Refer to the table of [Pr. PB08] for details.</p>	33.7 [ms]	01 to 10000	Each										

5. PARAMETERS

No.	Symbol	Name and function	Initial value [unit]	Setting range	Each/ Common															
PB11	VDC	Speed differential compensation This is used to set the differential compensation. To enable the parameter, select "Continuous PID control enabled (_ _ 3 _)" of "PI-PID switching control selection" in [Pr. PB24].	980	0 to 1000	Each															
PB12	OVA	Overshoot amount compensation This is used to set a viscous friction torque or thrust to rated torque in percentage unit at servo motor rated speed or linear servo motor rated speed. When the response level is low or when the torque/thrust is limited, the efficiency of the parameter may be lower.	0 [%]	0 to 100	Each															
PB13	NH1	Machine resonance suppression filter 1 Set the notch frequency of the machine resonance suppression filter 1. When you select "Automatic setting (_ _ _ 1)" of "Filter tuning mode selection" in [Pr. PB01], this parameter will be adjusted automatically. When you select "Manual setting (_ _ _ 2)" of "Filter tuning mode selection" in [Pr. PB01], the setting value will be enabled.	4500 [Hz]	10 to 4500	Each															
PB14	NHQ1	Notch shape selection 1 Set the shape of the machine resonance suppression filter 1. When you select "Automatic setting (_ _ _ 1)" of "Filter tuning mode selection" in [Pr. PB01], this parameter will be adjusted automatically. Set manually for the manual setting.	Refer to Name and function column.		Each															
		<table border="1"> <thead> <tr> <th>Setting digit</th> <th>Explanation</th> <th>Initial value</th> </tr> </thead> <tbody> <tr> <td>_ _ _ x</td> <td>For manufacturer setting</td> <td>0h</td> </tr> <tr> <td>_ _ x _</td> <td>Notch depth selection 0: -40 dB 1: -14 dB 2: -8 dB 3: -4 dB</td> <td>0h</td> </tr> <tr> <td>_ x _ _</td> <td>Notch width selection 0: $\alpha = 2$ 1: $\alpha = 3$ 2: $\alpha = 4$ 3: $\alpha = 5$</td> <td>0h</td> </tr> <tr> <td>x _ _ _</td> <td>For manufacturer setting</td> <td>0h</td> </tr> </tbody> </table>	Setting digit	Explanation	Initial value	_ _ _ x	For manufacturer setting	0h	_ _ x _	Notch depth selection 0: -40 dB 1: -14 dB 2: -8 dB 3: -4 dB	0h	_ x _ _	Notch width selection 0: $\alpha = 2$ 1: $\alpha = 3$ 2: $\alpha = 4$ 3: $\alpha = 5$	0h	x _ _ _	For manufacturer setting	0h			
Setting digit	Explanation	Initial value																		
_ _ _ x	For manufacturer setting	0h																		
_ _ x _	Notch depth selection 0: -40 dB 1: -14 dB 2: -8 dB 3: -4 dB	0h																		
_ x _ _	Notch width selection 0: $\alpha = 2$ 1: $\alpha = 3$ 2: $\alpha = 4$ 3: $\alpha = 5$	0h																		
x _ _ _	For manufacturer setting	0h																		
PB15	NH2	Machine resonance suppression filter 2 Set the notch frequency of the machine resonance suppression filter 2. To enable the setting value, select "Enabled (_ _ _ 1)" of "Machine resonance suppression filter 2 selection" in [Pr. PB16].	4500 [Hz]	10 to 4500	Each															

5. PARAMETERS

No.	Symbol	Name and function	Initial value [unit]	Setting range	Each/ Common															
PB16	NHQ2	<p>Notch shape selection 2 Set the shape of the machine resonance suppression filter 2.</p> <table border="1"> <thead> <tr> <th>Setting digit</th> <th>Explanation</th> <th>Initial value</th> </tr> </thead> <tbody> <tr> <td>___x</td> <td>Machine resonance suppression filter 2 selection 0: Disabled 1: Enabled</td> <td>0h</td> </tr> <tr> <td>__x_</td> <td>Notch depth selection 0: -40 dB 1: -14 dB 2: -8 dB 3: -4 dB</td> <td>0h</td> </tr> <tr> <td>_x__</td> <td>Notch width selection 0: $\alpha = 2$ 1: $\alpha = 3$ 2: $\alpha = 4$ 3: $\alpha = 5$</td> <td>0h</td> </tr> <tr> <td>x___</td> <td>For manufacturer setting</td> <td>0h</td> </tr> </tbody> </table>	Setting digit	Explanation	Initial value	___x	Machine resonance suppression filter 2 selection 0: Disabled 1: Enabled	0h	__x_	Notch depth selection 0: -40 dB 1: -14 dB 2: -8 dB 3: -4 dB	0h	_x__	Notch width selection 0: $\alpha = 2$ 1: $\alpha = 3$ 2: $\alpha = 4$ 3: $\alpha = 5$	0h	x___	For manufacturer setting	0h	Refer to Name and function column.		Each
Setting digit	Explanation	Initial value																		
___x	Machine resonance suppression filter 2 selection 0: Disabled 1: Enabled	0h																		
__x_	Notch depth selection 0: -40 dB 1: -14 dB 2: -8 dB 3: -4 dB	0h																		
_x__	Notch width selection 0: $\alpha = 2$ 1: $\alpha = 3$ 2: $\alpha = 4$ 3: $\alpha = 5$	0h																		
x___	For manufacturer setting	0h																		
PB17	NHF	<p>Shaft resonance suppression filter This is used for setting the shaft resonance suppression filter. This is used to suppress a low-frequency machine vibration. When you select "Automatic setting (___0)" of "Shaft resonance suppression filter selection" in [Pr. PB23], the value will be calculated automatically from the servo motor you use and load to motor inertia ratio. It will not automatically calculated for the liner servo motor. Set manually for "Manual setting (___1)". When "Shaft resonance suppression filter selection" is "Disabled (___2)" in [Pr. PB23], the setting value of this parameter will be disabled. When you select "Enabled (___1)" of "Machine resonance suppression filter 4 selection" in [Pr. PB49], the shaft resonance suppression filter is not available.</p> <table border="1"> <thead> <tr> <th>Setting digit</th> <th>Explanation</th> <th>Initial value</th> </tr> </thead> <tbody> <tr> <td>__xx</td> <td>Shaft resonance suppression filter setting frequency selection This is used for setting the shaft resonance suppression filter. Refer to table 5.4 for settings. Set the value closest to the frequency you need.</td> <td>00h</td> </tr> <tr> <td>_x__</td> <td>Notch depth selection 0: -40 dB 1: -14 dB 2: -8 dB 3: -4 dB</td> <td>0h</td> </tr> <tr> <td>x___</td> <td>For manufacturer setting</td> <td>0h</td> </tr> </tbody> </table>	Setting digit	Explanation	Initial value	__xx	Shaft resonance suppression filter setting frequency selection This is used for setting the shaft resonance suppression filter. Refer to table 5.4 for settings. Set the value closest to the frequency you need.	00h	_x__	Notch depth selection 0: -40 dB 1: -14 dB 2: -8 dB 3: -4 dB	0h	x___	For manufacturer setting	0h	Refer to Name and function column.		Each			
Setting digit	Explanation	Initial value																		
__xx	Shaft resonance suppression filter setting frequency selection This is used for setting the shaft resonance suppression filter. Refer to table 5.4 for settings. Set the value closest to the frequency you need.	00h																		
_x__	Notch depth selection 0: -40 dB 1: -14 dB 2: -8 dB 3: -4 dB	0h																		
x___	For manufacturer setting	0h																		

5. PARAMETERS

No.	Symbol	Name and function	Initial value [unit]	Setting range	Each/ Common																																																																			
PB17	NHF	<p>Table 5.4 Shaft resonance suppression filter setting frequency selection</p> <table border="1"> <thead> <tr> <th>Setting value</th> <th>Frequency [Hz]</th> <th>Setting value</th> <th>Frequency [Hz]</th> </tr> </thead> <tbody> <tr><td>00</td><td>Disabled</td><td>10</td><td>562</td></tr> <tr><td>01</td><td>Disabled</td><td>11</td><td>529</td></tr> <tr><td>02</td><td>4500</td><td>12</td><td>500</td></tr> <tr><td>03</td><td>3000</td><td>13</td><td>473</td></tr> <tr><td>04</td><td>2250</td><td>14</td><td>450</td></tr> <tr><td>05</td><td>1800</td><td>15</td><td>428</td></tr> <tr><td>06</td><td>1500</td><td>16</td><td>409</td></tr> <tr><td>07</td><td>1285</td><td>17</td><td>391</td></tr> <tr><td>08</td><td>1125</td><td>18</td><td>375</td></tr> <tr><td>09</td><td>1000</td><td>19</td><td>360</td></tr> <tr><td>0A</td><td>900</td><td>1A</td><td>346</td></tr> <tr><td>0B</td><td>818</td><td>1B</td><td>333</td></tr> <tr><td>0C</td><td>750</td><td>1C</td><td>321</td></tr> <tr><td>0D</td><td>692</td><td>1D</td><td>310</td></tr> <tr><td>0E</td><td>642</td><td>1E</td><td>300</td></tr> <tr><td>0F</td><td>600</td><td>1F</td><td>290</td></tr> </tbody> </table>	Setting value	Frequency [Hz]	Setting value	Frequency [Hz]	00	Disabled	10	562	01	Disabled	11	529	02	4500	12	500	03	3000	13	473	04	2250	14	450	05	1800	15	428	06	1500	16	409	07	1285	17	391	08	1125	18	375	09	1000	19	360	0A	900	1A	346	0B	818	1B	333	0C	750	1C	321	0D	692	1D	310	0E	642	1E	300	0F	600	1F	290	Refer to Name and function column.	Each
Setting value	Frequency [Hz]	Setting value	Frequency [Hz]																																																																					
00	Disabled	10	562																																																																					
01	Disabled	11	529																																																																					
02	4500	12	500																																																																					
03	3000	13	473																																																																					
04	2250	14	450																																																																					
05	1800	15	428																																																																					
06	1500	16	409																																																																					
07	1285	17	391																																																																					
08	1125	18	375																																																																					
09	1000	19	360																																																																					
0A	900	1A	346																																																																					
0B	818	1B	333																																																																					
0C	750	1C	321																																																																					
0D	692	1D	310																																																																					
0E	642	1E	300																																																																					
0F	600	1F	290																																																																					
PB18	LPF	<p>Low-pass filter setting Set the low-pass filter. The following shows a relation of a required parameter to this parameter.</p> <table border="1"> <thead> <tr> <th>[Pr. PB23]</th> <th>[Pr. PB18]</th> </tr> </thead> <tbody> <tr> <td>__ 0 __ (Initial value)</td> <td>Automatic setting</td> </tr> <tr> <td>__ 1 __</td> <td>Setting value enabled</td> </tr> <tr> <td>__ 2 __</td> <td>Setting value disabled</td> </tr> </tbody> </table>	[Pr. PB23]	[Pr. PB18]	__ 0 __ (Initial value)	Automatic setting	__ 1 __	Setting value enabled	__ 2 __	Setting value disabled	3141 [rad/s]	100 to 18000	Each																																																											
[Pr. PB23]	[Pr. PB18]																																																																							
__ 0 __ (Initial value)	Automatic setting																																																																							
__ 1 __	Setting value enabled																																																																							
__ 2 __	Setting value disabled																																																																							

5. PARAMETERS

No.	Symbol	Name and function	Initial value [unit]	Setting range	Each/ Common														
PB19	VRF11	Vibration suppression control 1 - Vibration frequency Set the vibration frequency for vibration suppression control 1 to suppress low-frequency machine vibration. When "Vibration suppression control 1 tuning mode selection" is "Automatic setting (_ _ _ 1)" in [Pr. PB02], this parameter will be set automatically. Set manually for "Manual setting (_ _ _ 2)". Refer to section 7.1.5 for details.	100.0 [Hz]	01 to 3000	Each														
PB20	VRF12	Vibration suppression control 1 - Resonance frequency Set the resonance frequency for vibration suppression control 1 to suppress low-frequency machine vibration. When "Vibration suppression control 1 tuning mode selection" is "Automatic setting (_ _ _ 1)" in [Pr. PB02], this parameter will be set automatically. Set manually for "Manual setting (_ _ _ 2)". Refer to section 7.1.5 for details.	100.0 [Hz]	01 to 3000	Each														
PB21	VRF13	Vibration suppression control 1 - Vibration frequency damping Set a damping of the vibration frequency for vibration suppression control 1 to suppress low-frequency machine vibration. When "Vibration suppression control 1 tuning mode selection" is "Automatic setting (_ _ _ 1)" in [Pr. PB02], this parameter will be set automatically. Set manually for "Manual setting (_ _ _ 2)". Refer to section 7.1.5 for details.	0.00	000 to 030	Each														
PB22	VRF14	Vibration suppression control 1 - Resonance frequency damping Set a damping of the resonance frequency for vibration suppression control 1 to suppress low-frequency machine vibration. When "Vibration suppression control 1 tuning mode selection" is "Automatic setting (_ _ _ 1)" in [Pr. PB02], this parameter will be set automatically. Set manually for "Manual setting (_ _ _ 2)". Refer to section 7.1.5 for details.	0.00	000 to 030	Each														
PB23	VFBF	Low-pass filter selection Select the shaft resonance suppression filter and low-pass filter. <table border="1" data-bbox="347 1081 1155 1532"> <thead> <tr> <th>Setting digit</th> <th>Explanation</th> <th>Initial value</th> </tr> </thead> <tbody> <tr> <td>_ _ _ x</td> <td>Shaft resonance suppression filter selection 0: Automatic setting 1: Manual setting 2: Disabled When you select "Enabled (_ _ _ 1)" of "Machine resonance suppression filter 4 selection" in [Pr. PB49], the shaft resonance suppression filter is not available.</td> <td>0h</td> </tr> <tr> <td>_ _ x _</td> <td>Low-pass filter selection 0: Automatic setting 1: Manual setting 2: Disabled</td> <td>0h</td> </tr> <tr> <td>_ x _ _</td> <td>For manufacturer setting</td> <td>0h</td> </tr> <tr> <td>x _ _ _</td> <td></td> <td>0h</td> </tr> </tbody> </table>	Setting digit	Explanation	Initial value	_ _ _ x	Shaft resonance suppression filter selection 0: Automatic setting 1: Manual setting 2: Disabled When you select "Enabled (_ _ _ 1)" of "Machine resonance suppression filter 4 selection" in [Pr. PB49], the shaft resonance suppression filter is not available.	0h	_ _ x _	Low-pass filter selection 0: Automatic setting 1: Manual setting 2: Disabled	0h	_ x _ _	For manufacturer setting	0h	x _ _ _		0h	Refer to Name and function column.	Each
Setting digit	Explanation	Initial value																	
_ _ _ x	Shaft resonance suppression filter selection 0: Automatic setting 1: Manual setting 2: Disabled When you select "Enabled (_ _ _ 1)" of "Machine resonance suppression filter 4 selection" in [Pr. PB49], the shaft resonance suppression filter is not available.	0h																	
_ _ x _	Low-pass filter selection 0: Automatic setting 1: Manual setting 2: Disabled	0h																	
_ x _ _	For manufacturer setting	0h																	
x _ _ _		0h																	

5. PARAMETERS

No.	Symbol	Name and function	Initial value [unit]	Setting range	Each/ Common														
PB24	*MVS	<p>Slight vibration suppression control Select the slight vibration suppression control and PI-PID switching control.</p> <table border="1"> <thead> <tr> <th>Setting digit</th> <th>Explanation</th> <th>Initial value</th> </tr> </thead> <tbody> <tr> <td>___x</td> <td> <p>Slight vibration suppression control selection</p> <p>0: Disabled 1: Enabled</p> <p>To enable the slight vibration suppression control, select "Manual mode (___3)" of "Gain adjustment mode selection" in [Pr. PA08]. Slight vibration suppression control cannot be used in the speed control mode.</p> </td> <td>0h</td> </tr> <tr> <td>__x_</td> <td> <p>PI-PID switching control selection</p> <p>0: PI control enabled (Switching to PID control is possible with commands of controller.) 3: Continuous PID control enabled</p> </td> <td>0h</td> </tr> <tr> <td>_x__</td> <td rowspan="2">For manufacturer setting</td> <td>0h</td> </tr> <tr> <td>x___</td> <td>0h</td> </tr> </tbody> </table>	Setting digit	Explanation	Initial value	___x	<p>Slight vibration suppression control selection</p> <p>0: Disabled 1: Enabled</p> <p>To enable the slight vibration suppression control, select "Manual mode (___3)" of "Gain adjustment mode selection" in [Pr. PA08]. Slight vibration suppression control cannot be used in the speed control mode.</p>	0h	__x_	<p>PI-PID switching control selection</p> <p>0: PI control enabled (Switching to PID control is possible with commands of controller.) 3: Continuous PID control enabled</p>	0h	_x__	For manufacturer setting	0h	x___	0h	Refer to Name and function column.		Each
Setting digit	Explanation	Initial value																	
___x	<p>Slight vibration suppression control selection</p> <p>0: Disabled 1: Enabled</p> <p>To enable the slight vibration suppression control, select "Manual mode (___3)" of "Gain adjustment mode selection" in [Pr. PA08]. Slight vibration suppression control cannot be used in the speed control mode.</p>	0h																	
__x_	<p>PI-PID switching control selection</p> <p>0: PI control enabled (Switching to PID control is possible with commands of controller.) 3: Continuous PID control enabled</p>	0h																	
_x__	For manufacturer setting	0h																	
x___		0h																	
PB26	*CDP	<p>Gain switching function Select the gain switching condition. Set conditions to enable the gain switching values set in [Pr. PB29] to [Pr. PB36] and [Pr. PB56] to [Pr. PB60].</p> <table border="1"> <thead> <tr> <th>Setting digit</th> <th>Explanation</th> <th>Initial value</th> </tr> </thead> <tbody> <tr> <td>___x</td> <td> <p>Gain switching selection</p> <p>0: Disabled 1: Control command from controller is enabled 2: Command frequency 3: Droop pulses 4: Servo motor speed/linear servo motor speed</p> </td> <td>0h</td> </tr> <tr> <td>__x_</td> <td> <p>Gain switching condition selection</p> <p>0: Gain after switching is enabled with gain switching condition or more 1: Gain after switching is enabled with gain switching condition or less</p> </td> <td>0h</td> </tr> <tr> <td>_x__</td> <td rowspan="2">For manufacturer setting</td> <td>0h</td> </tr> <tr> <td>x___</td> <td>0h</td> </tr> </tbody> </table>	Setting digit	Explanation	Initial value	___x	<p>Gain switching selection</p> <p>0: Disabled 1: Control command from controller is enabled 2: Command frequency 3: Droop pulses 4: Servo motor speed/linear servo motor speed</p>	0h	__x_	<p>Gain switching condition selection</p> <p>0: Gain after switching is enabled with gain switching condition or more 1: Gain after switching is enabled with gain switching condition or less</p>	0h	_x__	For manufacturer setting	0h	x___	0h	Refer to Name and function column.		Each
Setting digit	Explanation	Initial value																	
___x	<p>Gain switching selection</p> <p>0: Disabled 1: Control command from controller is enabled 2: Command frequency 3: Droop pulses 4: Servo motor speed/linear servo motor speed</p>	0h																	
__x_	<p>Gain switching condition selection</p> <p>0: Gain after switching is enabled with gain switching condition or more 1: Gain after switching is enabled with gain switching condition or less</p>	0h																	
_x__	For manufacturer setting	0h																	
x___		0h																	
PB27	CDL	<p>Gain switching condition This is used to set the value of gain switching (command frequency, droop pulses, and servo motor speed/linear servo motor speed) selected in [Pr. PB26]. The set value unit differs depending on the switching condition item. (Refer to section 7.2.3) The unit "r/min" will be "mm/s" for linear servo motors.</p>	10 [kpps]/ [pulse]/ [r/min]	0 to 65535	Each														
PB28	CDT	<p>Gain switching time constant This is used to set the time constant at which the gains will change in response to the conditions set in [Pr. PB26] and [Pr. PB27].</p>	1 [ms]	0 to 100	Each														
PB29	GD2B	<p>Load to motor inertia ratio/load to motor mass ratio after gain switching This is used to set the load to motor inertia ratio/load to motor mass ratio when gain switching is enabled. This parameter is enabled only when you select "Manual mode (___3)" of "Gain adjustment mode selection" in [Pr. PA08].</p>	7.00 [Multiplier]	000 to 30000	Each														
PB30	PG2B	<p>Position loop gain after gain switching Set the position loop gain when the gain switching is enabled. When you set a value less than 1.0 rad/s, the value will be the same as [Pr. PB08]. This parameter is enabled only when you select "Manual mode (___3)" of "Gain adjustment mode selection" in [Pr. PA08].</p>	0.0 [rad/s]	00 to 20000	Each														

5. PARAMETERS

No.	Symbol	Name and function	Initial value [unit]	Setting range	Each/ Common
PB31	VG2B	Speed loop gain after gain switching Set the speed loop gain when the gain switching is enabled. When you set a value less than 20 rad/s, the value will be the same as [Pr. PB09]. This parameter is enabled only when you select "Manual mode (_ _ _ 3)" of "Gain adjustment mode selection" in [Pr. PA08].	0 [rad/s]	0 to 65535	Each
PB32	VICB	Speed integral compensation after gain switching Set the speed integral compensation when the gain changing is enabled. When you set a value less than 0.1 ms, the value will be the same as [Pr. PB10]. This parameter is enabled only when you select "Manual mode (_ _ _ 3)" of "Gain adjustment mode selection" in [Pr. PA08].	0.0 [ms]	00 to 50000	Each
PB33	VRF11B	Vibration suppression control 1 - Vibration frequency after gain switching Set the vibration frequency for vibration suppression control 1 when the gain switching is enabled. When you set a value less than 0.1 Hz, the value will be the same as [Pr. PB19]. This parameter will be enabled only when the following conditions are fulfilled. <ul style="list-style-type: none"> • "Gain adjustment mode selection" in [Pr. PA08] is "Manual mode (_ _ _ 3)". • "Vibration suppression control 1 tuning mode selection" in [Pr. PB02] is "Manual setting (_ _ _ 2)". • "Gain switching selection" in [Pr. PB26] is "Control command from controller is enabled (_ _ _ 1)". Switching during driving may cause a shock. Be sure to switch them after the servo motor or linear servo motor stops.	0.0 [Hz]	00 to 3000	Each
PB34	VRF12B	Vibration suppression control 1 - Resonance frequency after gain switching Set the resonance frequency for vibration suppression control 1 when the gain switching is enabled. When you set a value less than 0.1 Hz, the value will be the same as [Pr. PB20]. This parameter will be enabled only when the following conditions are fulfilled. <ul style="list-style-type: none"> • "Gain adjustment mode selection" in [Pr. PA08] is "Manual mode (_ _ _ 3)". • "Vibration suppression control 1 tuning mode selection" in [Pr. PB02] is "Manual setting (_ _ _ 2)". • "Gain switching selection" in [Pr. PB26] is "Control command from controller is enabled (_ _ _ 1)". Switching during driving may cause a shock. Be sure to switch them after the servo motor or linear servo motor stops.	0.0 [Hz]	00 to 3000	Each
PB35	VRF13B	Vibration suppression control 1 - Vibration frequency damping after gain switching Set a damping of the vibration frequency for vibration suppression control 1 when the gain switching is enabled. This parameter will be enabled only when the following conditions are fulfilled. <ul style="list-style-type: none"> • "Gain adjustment mode selection" in [Pr. PA08] is "Manual mode (_ _ _ 3)". • "Vibration suppression control 1 tuning mode selection" in [Pr. PB02] is "Manual setting (_ _ _ 2)". • "Gain switching selection" in [Pr. PB26] is "Control command from controller is enabled (_ _ _ 1)". Switching during driving may cause a shock. Be sure to switch them after the servo motor or linear servo motor stops.	0.00	000 to 030	Each
PB36	VRF14B	Vibration suppression control 1 - Resonance frequency damping after gain switching Set a damping of the resonance frequency for vibration suppression control 1 when the gain switching is enabled. This parameter will be enabled only when the following conditions are fulfilled. <ul style="list-style-type: none"> • "Gain adjustment mode selection" in [Pr. PA08] is "Manual mode (_ _ _ 3)". • "Vibration suppression control 1 tuning mode selection" in [Pr. PB02] is "Manual setting (_ _ _ 2)". • "Gain switching selection" in [Pr. PB26] is "Control command from controller is enabled (_ _ _ 1)". Switching during driving may cause a shock. Be sure to switch them after the servo motor or linear servo motor stops.	0.00	000 to 0.30	Each

5. PARAMETERS

No.	Symbol	Name and function	Initial value [unit]	Setting range	Each/ Common																																																																																																																																																																																																																	
PB45	CNHF	Command notch filter Set the command notch filter. <table border="1" style="margin-top: 10px;"> <thead> <tr> <th>Setting digit</th> <th>Explanation</th> <th>Initial value</th> </tr> </thead> <tbody> <tr> <td>__ x x</td> <td>Command notch filter setting frequency selection Refer to table 5.5 for the relation of setting values to frequency.</td> <td>00h</td> </tr> <tr> <td>_ x _ _</td> <td>Notch depth selection Refer to table 5.6 for details.</td> <td>0h</td> </tr> <tr> <td>x _ _ _</td> <td>For manufacturer setting</td> <td>0h</td> </tr> </tbody> </table> Table 5.5 Command notch filter setting frequency selection <table border="1" style="margin-top: 10px; width: 100%;"> <thead> <tr> <th>Setting value</th> <th>Frequency [Hz]</th> <th>Setting value</th> <th>Frequency [Hz]</th> <th>Setting value</th> <th>Frequency [Hz]</th> </tr> </thead> <tbody> <tr><td>00</td><td>Disabled</td><td>20</td><td>70</td><td>40</td><td>17.6</td></tr> <tr><td>01</td><td>2250</td><td>21</td><td>66</td><td>41</td><td>16.5</td></tr> <tr><td>02</td><td>1125</td><td>22</td><td>62</td><td>42</td><td>15.6</td></tr> <tr><td>03</td><td>750</td><td>23</td><td>59</td><td>43</td><td>14.8</td></tr> <tr><td>04</td><td>562</td><td>24</td><td>56</td><td>44</td><td>14.1</td></tr> <tr><td>05</td><td>450</td><td>25</td><td>53</td><td>45</td><td>13.4</td></tr> <tr><td>06</td><td>375</td><td>26</td><td>51</td><td>46</td><td>12.8</td></tr> <tr><td>07</td><td>321</td><td>27</td><td>48</td><td>47</td><td>12.2</td></tr> <tr><td>08</td><td>281</td><td>28</td><td>46</td><td>48</td><td>11.7</td></tr> <tr><td>09</td><td>250</td><td>29</td><td>45</td><td>49</td><td>11.3</td></tr> <tr><td>0A</td><td>225</td><td>2A</td><td>43</td><td>4A</td><td>10.8</td></tr> <tr><td>0B</td><td>204</td><td>2B</td><td>41</td><td>4B</td><td>10.4</td></tr> <tr><td>0C</td><td>187</td><td>2C</td><td>40</td><td>4C</td><td>10</td></tr> <tr><td>0D</td><td>173</td><td>2D</td><td>38</td><td>4D</td><td>9.7</td></tr> <tr><td>0E</td><td>160</td><td>2E</td><td>37</td><td>4E</td><td>9.4</td></tr> <tr><td>0F</td><td>150</td><td>2F</td><td>36</td><td>4F</td><td>9.1</td></tr> <tr><td>10</td><td>140</td><td>30</td><td>35.2</td><td>50</td><td>8.8</td></tr> <tr><td>11</td><td>132</td><td>31</td><td>33.1</td><td>51</td><td>8.3</td></tr> <tr><td>12</td><td>125</td><td>32</td><td>31.3</td><td>52</td><td>7.8</td></tr> <tr><td>13</td><td>118</td><td>33</td><td>29.6</td><td>53</td><td>7.4</td></tr> <tr><td>14</td><td>112</td><td>34</td><td>28.1</td><td>54</td><td>7.0</td></tr> <tr><td>15</td><td>107</td><td>35</td><td>26.8</td><td>55</td><td>6.7</td></tr> <tr><td>16</td><td>102</td><td>36</td><td>25.6</td><td>56</td><td>6.4</td></tr> <tr><td>17</td><td>97</td><td>37</td><td>24.5</td><td>57</td><td>6.1</td></tr> <tr><td>18</td><td>93</td><td>38</td><td>23.4</td><td>58</td><td>5.9</td></tr> <tr><td>19</td><td>90</td><td>39</td><td>22.5</td><td>59</td><td>5.6</td></tr> <tr><td>1A</td><td>86</td><td>3A</td><td>21.6</td><td>5A</td><td>5.4</td></tr> <tr><td>1B</td><td>83</td><td>3B</td><td>20.8</td><td>5B</td><td>5.2</td></tr> <tr><td>1C</td><td>80</td><td>3C</td><td>20.1</td><td>5C</td><td>5.0</td></tr> <tr><td>1D</td><td>77</td><td>3D</td><td>19.4</td><td>5D</td><td>4.9</td></tr> <tr><td>1E</td><td>75</td><td>3E</td><td>18.8</td><td>5E</td><td>4.7</td></tr> <tr><td>1F</td><td>72</td><td>3F</td><td>18.2</td><td>5F</td><td>4.5</td></tr> </tbody> </table>	Setting digit	Explanation	Initial value	__ x x	Command notch filter setting frequency selection Refer to table 5.5 for the relation of setting values to frequency.	00h	_ x _ _	Notch depth selection Refer to table 5.6 for details.	0h	x _ _ _	For manufacturer setting	0h	Setting value	Frequency [Hz]	Setting value	Frequency [Hz]	Setting value	Frequency [Hz]	00	Disabled	20	70	40	17.6	01	2250	21	66	41	16.5	02	1125	22	62	42	15.6	03	750	23	59	43	14.8	04	562	24	56	44	14.1	05	450	25	53	45	13.4	06	375	26	51	46	12.8	07	321	27	48	47	12.2	08	281	28	46	48	11.7	09	250	29	45	49	11.3	0A	225	2A	43	4A	10.8	0B	204	2B	41	4B	10.4	0C	187	2C	40	4C	10	0D	173	2D	38	4D	9.7	0E	160	2E	37	4E	9.4	0F	150	2F	36	4F	9.1	10	140	30	35.2	50	8.8	11	132	31	33.1	51	8.3	12	125	32	31.3	52	7.8	13	118	33	29.6	53	7.4	14	112	34	28.1	54	7.0	15	107	35	26.8	55	6.7	16	102	36	25.6	56	6.4	17	97	37	24.5	57	6.1	18	93	38	23.4	58	5.9	19	90	39	22.5	59	5.6	1A	86	3A	21.6	5A	5.4	1B	83	3B	20.8	5B	5.2	1C	80	3C	20.1	5C	5.0	1D	77	3D	19.4	5D	4.9	1E	75	3E	18.8	5E	4.7	1F	72	3F	18.2	5F	4.5	Refer to Name and function column.	Each
Setting digit	Explanation	Initial value																																																																																																																																																																																																																				
__ x x	Command notch filter setting frequency selection Refer to table 5.5 for the relation of setting values to frequency.	00h																																																																																																																																																																																																																				
_ x _ _	Notch depth selection Refer to table 5.6 for details.	0h																																																																																																																																																																																																																				
x _ _ _	For manufacturer setting	0h																																																																																																																																																																																																																				
Setting value	Frequency [Hz]	Setting value	Frequency [Hz]	Setting value	Frequency [Hz]																																																																																																																																																																																																																	
00	Disabled	20	70	40	17.6																																																																																																																																																																																																																	
01	2250	21	66	41	16.5																																																																																																																																																																																																																	
02	1125	22	62	42	15.6																																																																																																																																																																																																																	
03	750	23	59	43	14.8																																																																																																																																																																																																																	
04	562	24	56	44	14.1																																																																																																																																																																																																																	
05	450	25	53	45	13.4																																																																																																																																																																																																																	
06	375	26	51	46	12.8																																																																																																																																																																																																																	
07	321	27	48	47	12.2																																																																																																																																																																																																																	
08	281	28	46	48	11.7																																																																																																																																																																																																																	
09	250	29	45	49	11.3																																																																																																																																																																																																																	
0A	225	2A	43	4A	10.8																																																																																																																																																																																																																	
0B	204	2B	41	4B	10.4																																																																																																																																																																																																																	
0C	187	2C	40	4C	10																																																																																																																																																																																																																	
0D	173	2D	38	4D	9.7																																																																																																																																																																																																																	
0E	160	2E	37	4E	9.4																																																																																																																																																																																																																	
0F	150	2F	36	4F	9.1																																																																																																																																																																																																																	
10	140	30	35.2	50	8.8																																																																																																																																																																																																																	
11	132	31	33.1	51	8.3																																																																																																																																																																																																																	
12	125	32	31.3	52	7.8																																																																																																																																																																																																																	
13	118	33	29.6	53	7.4																																																																																																																																																																																																																	
14	112	34	28.1	54	7.0																																																																																																																																																																																																																	
15	107	35	26.8	55	6.7																																																																																																																																																																																																																	
16	102	36	25.6	56	6.4																																																																																																																																																																																																																	
17	97	37	24.5	57	6.1																																																																																																																																																																																																																	
18	93	38	23.4	58	5.9																																																																																																																																																																																																																	
19	90	39	22.5	59	5.6																																																																																																																																																																																																																	
1A	86	3A	21.6	5A	5.4																																																																																																																																																																																																																	
1B	83	3B	20.8	5B	5.2																																																																																																																																																																																																																	
1C	80	3C	20.1	5C	5.0																																																																																																																																																																																																																	
1D	77	3D	19.4	5D	4.9																																																																																																																																																																																																																	
1E	75	3E	18.8	5E	4.7																																																																																																																																																																																																																	
1F	72	3F	18.2	5F	4.5																																																																																																																																																																																																																	

5. PARAMETERS

No.	Symbol	Name and function	Initial value [unit]	Setting range	Each/ Common																																				
PB45	CNHF	<p style="text-align: center;">Table 5.6 Notch depth selection</p> <table border="1" style="width: 100%; border-collapse: collapse;"> <thead> <tr> <th>Setting value</th> <th>Depth [dB]</th> <th>Setting value</th> <th>Depth [dB]</th> </tr> </thead> <tbody> <tr><td>0</td><td>-40.0</td><td>8</td><td>-6.0</td></tr> <tr><td>1</td><td>-24.1</td><td>9</td><td>-5.0</td></tr> <tr><td>2</td><td>-18.1</td><td>A</td><td>-4.1</td></tr> <tr><td>3</td><td>-14.5</td><td>B</td><td>-3.3</td></tr> <tr><td>4</td><td>-12.0</td><td>C</td><td>-2.5</td></tr> <tr><td>5</td><td>-10.1</td><td>D</td><td>-1.8</td></tr> <tr><td>6</td><td>-8.5</td><td>E</td><td>-1.2</td></tr> <tr><td>7</td><td>-7.2</td><td>F</td><td>-0.6</td></tr> </tbody> </table>	Setting value	Depth [dB]	Setting value	Depth [dB]	0	-40.0	8	-6.0	1	-24.1	9	-5.0	2	-18.1	A	-4.1	3	-14.5	B	-3.3	4	-12.0	C	-2.5	5	-10.1	D	-1.8	6	-8.5	E	-1.2	7	-7.2	F	-0.6	Refer to Name and function column.		Each
Setting value	Depth [dB]	Setting value	Depth [dB]																																						
0	-40.0	8	-6.0																																						
1	-24.1	9	-5.0																																						
2	-18.1	A	-4.1																																						
3	-14.5	B	-3.3																																						
4	-12.0	C	-2.5																																						
5	-10.1	D	-1.8																																						
6	-8.5	E	-1.2																																						
7	-7.2	F	-0.6																																						
PB46	NH3	<p>Machine resonance suppression filter 3</p> <p>Set the notch frequency of the machine resonance suppression filter 3.</p> <p>To enable the setting value, select "Enabled (_ _ _ 1)" of "Machine resonance suppression filter 3 selection" in [Pr. PB47].</p>	4500 [Hz]	10 to 4500	Each																																				
PB47	NHQ3	<p>Notch shape selection 3</p> <p>Set the shape of the machine resonance suppression filter 3.</p> <table border="1" style="width: 100%; border-collapse: collapse;"> <thead> <tr> <th>Setting digit</th> <th>Explanation</th> <th>Initial value</th> </tr> </thead> <tbody> <tr> <td>___ x</td> <td>Machine resonance suppression filter 3 selection 0: Disabled 1: Enabled</td> <td>0h</td> </tr> <tr> <td>__ x _</td> <td>Notch depth selection 0: -40 dB 1: -14 dB 2: -8 dB 3: -4 dB</td> <td>0h</td> </tr> <tr> <td>_ x _ _</td> <td>Notch width selection 0: $\alpha = 2$ 1: $\alpha = 3$ 2: $\alpha = 4$ 3: $\alpha = 5$</td> <td>0h</td> </tr> <tr> <td>x _ _ _</td> <td>For manufacturer setting</td> <td>0h</td> </tr> </tbody> </table>	Setting digit	Explanation	Initial value	___ x	Machine resonance suppression filter 3 selection 0: Disabled 1: Enabled	0h	__ x _	Notch depth selection 0: -40 dB 1: -14 dB 2: -8 dB 3: -4 dB	0h	_ x _ _	Notch width selection 0: $\alpha = 2$ 1: $\alpha = 3$ 2: $\alpha = 4$ 3: $\alpha = 5$	0h	x _ _ _	For manufacturer setting	0h	Refer to Name and function column.		Each																					
Setting digit	Explanation	Initial value																																							
___ x	Machine resonance suppression filter 3 selection 0: Disabled 1: Enabled	0h																																							
__ x _	Notch depth selection 0: -40 dB 1: -14 dB 2: -8 dB 3: -4 dB	0h																																							
_ x _ _	Notch width selection 0: $\alpha = 2$ 1: $\alpha = 3$ 2: $\alpha = 4$ 3: $\alpha = 5$	0h																																							
x _ _ _	For manufacturer setting	0h																																							
PB48	NH4	<p>Machine resonance suppression filter 4</p> <p>Set the notch frequency of the machine resonance suppression filter 4.</p> <p>To enable the setting value, select "Enabled (_ _ _ 1)" of "Machine resonance suppression filter 4 selection" in [Pr. PB49].</p>	4500 [Hz]	10 to 4500	Each																																				

5. PARAMETERS

No.	Symbol	Name and function	Initial value [unit]	Setting range	Each/ Common															
PB49	NHQ4	<p>Notch shape selection 4 Set the shape of the machine resonance suppression filter 4.</p> <table border="1"> <thead> <tr> <th>Setting digit</th> <th>Explanation</th> <th>Initial value</th> </tr> </thead> <tbody> <tr> <td>___x</td> <td>Machine resonance suppression filter 4 selection 0: Disabled 1: Enabled When you select "Enabled" of this digit, [Pr. PB17 Shaft resonance suppression filter] is not available.</td> <td>0h</td> </tr> <tr> <td>__x_</td> <td>Notch depth selection 0: -40 dB 1: -14 dB 2: -8 dB 3: -4 dB</td> <td>0h</td> </tr> <tr> <td>_x__</td> <td>Notch width selection 0: $\alpha = 2$ 1: $\alpha = 3$ 2: $\alpha = 4$ 3: $\alpha = 5$</td> <td>0h</td> </tr> <tr> <td>x___</td> <td>For manufacturer setting</td> <td>0h</td> </tr> </tbody> </table>	Setting digit	Explanation	Initial value	___x	Machine resonance suppression filter 4 selection 0: Disabled 1: Enabled When you select "Enabled" of this digit, [Pr. PB17 Shaft resonance suppression filter] is not available.	0h	__x_	Notch depth selection 0: -40 dB 1: -14 dB 2: -8 dB 3: -4 dB	0h	_x__	Notch width selection 0: $\alpha = 2$ 1: $\alpha = 3$ 2: $\alpha = 4$ 3: $\alpha = 5$	0h	x___	For manufacturer setting	0h	Refer to Name and function column.		Each
Setting digit	Explanation	Initial value																		
___x	Machine resonance suppression filter 4 selection 0: Disabled 1: Enabled When you select "Enabled" of this digit, [Pr. PB17 Shaft resonance suppression filter] is not available.	0h																		
__x_	Notch depth selection 0: -40 dB 1: -14 dB 2: -8 dB 3: -4 dB	0h																		
_x__	Notch width selection 0: $\alpha = 2$ 1: $\alpha = 3$ 2: $\alpha = 4$ 3: $\alpha = 5$	0h																		
x___	For manufacturer setting	0h																		
PB50	NH5	<p>Machine resonance suppression filter 5 Set the notch frequency of the machine resonance suppression filter 5. To enable the setting value, select "Enabled (___1)" of "Machine resonance suppression filter 5 selection" in [Pr. PB51].</p>	4500 [Hz]	10 to 4500	Each															
PB51	NHQ5	<p>Notch shape selection 5 Set the shape of the machine resonance suppression filter 5. When you select "Enabled (___1)" of "Robust filter selection" in [Pr. PE41], the machine resonance suppression filter 5 is not available.</p> <table border="1"> <thead> <tr> <th>Setting digit</th> <th>Explanation</th> <th>Initial value</th> </tr> </thead> <tbody> <tr> <td>___x</td> <td>Machine resonance suppression filter 5 selection 0: Disabled 1: Enabled</td> <td>0h</td> </tr> <tr> <td>__x_</td> <td>Notch depth selection 0: -40 dB 1: -14 dB 2: -8 dB 3: -4 dB</td> <td>0h</td> </tr> <tr> <td>_x__</td> <td>Notch width selection 0: $\alpha = 2$ 1: $\alpha = 3$ 2: $\alpha = 4$ 3: $\alpha = 5$</td> <td>0h</td> </tr> <tr> <td>x___</td> <td>For manufacturer setting</td> <td>0h</td> </tr> </tbody> </table>	Setting digit	Explanation	Initial value	___x	Machine resonance suppression filter 5 selection 0: Disabled 1: Enabled	0h	__x_	Notch depth selection 0: -40 dB 1: -14 dB 2: -8 dB 3: -4 dB	0h	_x__	Notch width selection 0: $\alpha = 2$ 1: $\alpha = 3$ 2: $\alpha = 4$ 3: $\alpha = 5$	0h	x___	For manufacturer setting	0h	Refer to Name and function column.		Each
Setting digit	Explanation	Initial value																		
___x	Machine resonance suppression filter 5 selection 0: Disabled 1: Enabled	0h																		
__x_	Notch depth selection 0: -40 dB 1: -14 dB 2: -8 dB 3: -4 dB	0h																		
_x__	Notch width selection 0: $\alpha = 2$ 1: $\alpha = 3$ 2: $\alpha = 4$ 3: $\alpha = 5$	0h																		
x___	For manufacturer setting	0h																		
PB52	VRF21	<p>Vibration suppression control 2 - Vibration frequency Set the vibration frequency for vibration suppression control 2 to suppress low-frequency machine vibration. To enable this, select "3 inertia mode (___1)" of "Vibration suppression mode selection" in [Pr. PA24]. When "Vibration suppression control 2 tuning mode selection" is "Automatic setting (___1)" in [Pr. PB02], this parameter will be set automatically. Set manually for "Manual setting (___2)".</p>	100.0 [Hz]	01 to 3000	Each															

5. PARAMETERS

No.	Symbol	Name and function	Initial value [unit]	Setting range	Each/ Common
PB53	VRF22	Vibration suppression control 2 - Resonance frequency Set the resonance frequency for vibration suppression control 2 to suppress low-frequency machine vibration. To enable this, select "3 inertia mode (_ _ _ 1)" of "Vibration suppression mode selection" in [Pr. PA24]. When "Vibration suppression control 2 tuning mode selection" is "Automatic setting (_ _ 1 _)" in [Pr. PB02], this parameter will be set automatically. Set manually for "Manual setting (_ _ 2 _)".	100.0 [Hz]	01 to 3000	Each
PB54	VRF23	Vibration suppression control 2 - Vibration frequency damping Set a damping of the vibration frequency for vibration suppression control 2 to suppress low-frequency machine vibration. To enable this, select "3 inertia mode (_ _ _ 1)" of "Vibration suppression mode selection" in [Pr. PA24]. When "Vibration suppression control 2 tuning mode selection" is "Automatic setting (_ _ 1 _)" in [Pr. PB02], this parameter will be set automatically. Set manually for "Manual setting (_ _ 2 _)".	0.00	000 to 0.30	Each
PB55	VRF24	Vibration suppression control 2 - Resonance frequency damping Set a damping of the resonance frequency for vibration suppression control 2 to suppress low-frequency machine vibration. To enable this, select "3 inertia mode (_ _ _ 1)" of "Vibration suppression mode selection" in [Pr. PA24]. When "Vibration suppression control 2 tuning mode selection" is "Automatic setting (_ _ 1 _)" in [Pr. PB02], this parameter will be set automatically. Set manually for "Manual setting (_ _ 2 _)".	0.00	000 to 0.30	Each
PB56	VRF21B	Vibration suppression control 2 - Vibration frequency after gain switching Set the vibration frequency for vibration suppression control 2 when the gain switching is enabled. To enable this, select "3 inertia mode (_ _ _ 1)" of "Vibration suppression mode selection" in [Pr. PA24]. This parameter will be enabled only when the following conditions are fulfilled. • "Gain adjustment mode selection" in [Pr. PA08] is "Manual mode (_ _ _ 3)". • "Vibration suppression control 2 tuning mode selection" in [Pr. PB02] is "Manual setting (_ _ 2 _)". • "Gain switching selection" in [Pr. PB26] is "Control command from controller is enabled (_ _ _ 1)". Switching during driving may cause a shock. Be sure to switch them after the servo motor or linear servo motor stops.	0.0 [Hz]	00 to 3000	Each
PB57	VRF22B	Vibration suppression control 2 - Resonance frequency after gain switching Set the resonance frequency for vibration suppression control 2 when the gain switching is enabled. To enable this, select "3 inertia mode (_ _ _ 1)" of "Vibration suppression mode selection" in [Pr. PA24]. This parameter will be enabled only when the following conditions are fulfilled. • "Gain adjustment mode selection" in [Pr. PA08] is "Manual mode (_ _ _ 3)". • "Vibration suppression control 2 tuning mode selection" in [Pr. PB02] is "Manual setting (_ _ 2 _)". • "Gain switching selection" in [Pr. PB26] is "Control command from controller is enabled (_ _ _ 1)". Switching during driving may cause a shock. Be sure to switch them after the servo motor or linear servo motor stops.	0.0 [Hz]	00 to 3000	Each

5. PARAMETERS

No.	Symbol	Name and function	Initial value [unit]	Setting range	Each/ Common
PB58	VRF23B	<p>Vibration suppression control 2 - Vibration frequency damping after gain switching</p> <p>Set a damping of the vibration frequency for vibration suppression control 2 when the gain switching is enabled.</p> <p>To enable this, select "3 inertia mode (_ _ _ 1)" of "Vibration suppression mode selection" in [Pr. PA24].</p> <p>This parameter will be enabled only when the following conditions are fulfilled.</p> <ul style="list-style-type: none"> • "Gain adjustment mode selection" in [Pr. PA08] is "Manual mode (_ _ _ 3)". • "Vibration suppression control 2 tuning mode selection" in [Pr. PB02] is "Manual setting (_ _ 2 _)". • "Gain switching selection" in [Pr. PB26] is "Control command from controller is enabled (_ _ _ 1)". <p>Switching during driving may cause a shock. Be sure to switch them after the servo motor or linear servo motor stops.</p>	0.00	000 to 0.30	Each
PB59	VRF24B	<p>Vibration suppression control 2 - Resonance frequency damping after gain switching</p> <p>Set a damping of the resonance frequency for vibration suppression control 2 when the gain switching is enabled.</p> <p>To enable this, select "3 inertia mode (_ _ _ 1)" of "Vibration suppression mode selection" in [Pr. PA24].</p> <p>This parameter will be enabled only when the following conditions are fulfilled.</p> <ul style="list-style-type: none"> • "Gain adjustment mode selection" in [Pr. PA08] is "Manual mode (_ _ _ 3)". • "Vibration suppression control 2 tuning mode selection" in [Pr. PB02] is "Manual setting (_ _ 2 _)". • "Gain switching selection" in [Pr. PB26] is "Control command from controller is enabled (_ _ _ 1)". <p>Switching during driving may cause a shock. Be sure to switch them after the servo motor or linear servo motor stops.</p>	0.00	000 to 0.30	Each
PB60	PG1B	<p>Model loop gain after gain switching</p> <p>Set the model loop gain when the gain switching is enabled.</p> <p>When you set a value less than 1.0 rad/s, the value will be the same as [Pr. PB07].</p> <p>This parameter will be enabled only when the following conditions are fulfilled.</p> <ul style="list-style-type: none"> • "Gain adjustment mode selection" in [Pr. PA08] is "Manual mode (_ _ _ 3)". • "Gain switching selection" in [Pr. PB26] is "Control command from controller is enabled (_ _ _ 1)". <p>Switching during driving may cause a shock. Be sure to switch them after the servo motor or linear servo motor stops.</p>	0.0 [rad/s]	00 to 20000	Each

5. PARAMETERS

5.2.3 Extension setting parameters ([Pr. PC__])

No.	Symbol	Name and function	Initial value [unit]	Setting range	Each/ Common																									
PC01	ERZ	<p>Error excessive alarm level</p> <p>Set an error excessive alarm level.</p> <p>Set this per rev. for rotary servo motors and direct drive motors. Setting "0" will be 3 rev. Setting over 200 rev will be clamped with 200 rev.</p> <p>Set this per mm for linear servo motors. Setting "0" will be 100 mm.</p> <p>Note. Setting can be changed in [Pr. PC06].</p>	0 [rev]/ [mm] (Note)	0 to 1000	Each																									
PC02	MBR	<p>Electromagnetic brake sequence output</p> <p>This is used to set the delay time between MBR (Electromagnetic brake interlock) and the base drive circuit is shut-off.</p>	0 [ms]	0 to 1000	Each																									
PC03	*ENRS	<p>Encoder output pulse selection</p> <p>This is used to select the encoder pulse direction and encoder output pulse setting.</p> <p>This parameter is not available with C-axis.</p> <table border="1" style="width: 100%; border-collapse: collapse;"> <thead> <tr> <th style="width: 15%;">Setting digit</th> <th style="width: 65%;">Explanation</th> <th style="width: 20%;">Initial value</th> </tr> </thead> <tbody> <tr> <td style="text-align: center;">_ _ _ x</td> <td> <p>Encoder output pulse phase selection</p> <p>0: Increasing A-phase 90° in CCW or positive direction</p> <p>1: Increasing A-phase 90° in CW or negative direction</p> <table border="1" style="width: 100%; border-collapse: collapse; margin-top: 10px;"> <thead> <tr> <th rowspan="2" style="width: 10%;">Setting value</th> <th colspan="2" style="text-align: center;">Servo motor rotation direction/ linear servo motor travel direction</th> </tr> <tr> <th style="width: 45%;">CCW or positive direction</th> <th style="width: 45%;">CW or negative direction</th> </tr> </thead> <tbody> <tr> <td style="text-align: center;">0</td> <td style="text-align: center;"> A-phase B-phase </td> <td style="text-align: center;"> A-phase B-phase </td> </tr> <tr> <td style="text-align: center;">1</td> <td style="text-align: center;"> A-phase B-phase </td> <td style="text-align: center;"> A-phase B-phase </td> </tr> </tbody> </table> </td> <td style="text-align: center;">0h</td> </tr> <tr> <td style="text-align: center;">_ _ x _</td> <td> <p>Encoder output pulse setting selection</p> <p>0: Output pulse setting (When "_ 1 0_" is set to this parameter, [AL. 37 Parameter error] will occur.)</p> <p>1: Division ratio setting</p> <p>3: A/B-phase pulse electronic gear setting</p> <p>For linear servo motors, selecting "0" will output as division ratio setting because the output pulse setting is not available.</p> </td> <td style="text-align: center;">0h</td> </tr> <tr> <td style="text-align: center;">_ x _ _</td> <td> <p>Selection of the encoders for encoder output pulse</p> <p>This is used for selecting an encoder for servo amplifier output.</p> <p>0: Servo motor encoder</p> <p>1: Load-side encoder</p> <p>Use [Pr. PA16] only in the fully closed loop system.</p> <p>If "1" is set other than in the fully closed loop system, [AL. 37 Parameter error] will occur.</p> </td> <td style="text-align: center;">0h</td> </tr> <tr> <td style="text-align: center;">x _ _ _</td> <td>For manufacturer setting</td> <td style="text-align: center;">0h</td> </tr> </tbody> </table>	Setting digit	Explanation	Initial value	_ _ _ x	<p>Encoder output pulse phase selection</p> <p>0: Increasing A-phase 90° in CCW or positive direction</p> <p>1: Increasing A-phase 90° in CW or negative direction</p> <table border="1" style="width: 100%; border-collapse: collapse; margin-top: 10px;"> <thead> <tr> <th rowspan="2" style="width: 10%;">Setting value</th> <th colspan="2" style="text-align: center;">Servo motor rotation direction/ linear servo motor travel direction</th> </tr> <tr> <th style="width: 45%;">CCW or positive direction</th> <th style="width: 45%;">CW or negative direction</th> </tr> </thead> <tbody> <tr> <td style="text-align: center;">0</td> <td style="text-align: center;"> A-phase B-phase </td> <td style="text-align: center;"> A-phase B-phase </td> </tr> <tr> <td style="text-align: center;">1</td> <td style="text-align: center;"> A-phase B-phase </td> <td style="text-align: center;"> A-phase B-phase </td> </tr> </tbody> </table>	Setting value	Servo motor rotation direction/ linear servo motor travel direction		CCW or positive direction	CW or negative direction	0	A-phase B-phase	A-phase B-phase	1	A-phase B-phase	A-phase B-phase	0h	_ _ x _	<p>Encoder output pulse setting selection</p> <p>0: Output pulse setting (When "_ 1 0_" is set to this parameter, [AL. 37 Parameter error] will occur.)</p> <p>1: Division ratio setting</p> <p>3: A/B-phase pulse electronic gear setting</p> <p>For linear servo motors, selecting "0" will output as division ratio setting because the output pulse setting is not available.</p>	0h	_ x _ _	<p>Selection of the encoders for encoder output pulse</p> <p>This is used for selecting an encoder for servo amplifier output.</p> <p>0: Servo motor encoder</p> <p>1: Load-side encoder</p> <p>Use [Pr. PA16] only in the fully closed loop system.</p> <p>If "1" is set other than in the fully closed loop system, [AL. 37 Parameter error] will occur.</p>	0h	x _ _ _	For manufacturer setting	0h	Refer to Name and function column.	Each
Setting digit	Explanation	Initial value																												
_ _ _ x	<p>Encoder output pulse phase selection</p> <p>0: Increasing A-phase 90° in CCW or positive direction</p> <p>1: Increasing A-phase 90° in CW or negative direction</p> <table border="1" style="width: 100%; border-collapse: collapse; margin-top: 10px;"> <thead> <tr> <th rowspan="2" style="width: 10%;">Setting value</th> <th colspan="2" style="text-align: center;">Servo motor rotation direction/ linear servo motor travel direction</th> </tr> <tr> <th style="width: 45%;">CCW or positive direction</th> <th style="width: 45%;">CW or negative direction</th> </tr> </thead> <tbody> <tr> <td style="text-align: center;">0</td> <td style="text-align: center;"> A-phase B-phase </td> <td style="text-align: center;"> A-phase B-phase </td> </tr> <tr> <td style="text-align: center;">1</td> <td style="text-align: center;"> A-phase B-phase </td> <td style="text-align: center;"> A-phase B-phase </td> </tr> </tbody> </table>	Setting value	Servo motor rotation direction/ linear servo motor travel direction		CCW or positive direction	CW or negative direction	0	A-phase B-phase	A-phase B-phase	1	A-phase B-phase	A-phase B-phase	0h																	
Setting value	Servo motor rotation direction/ linear servo motor travel direction																													
	CCW or positive direction	CW or negative direction																												
0	A-phase B-phase	A-phase B-phase																												
1	A-phase B-phase	A-phase B-phase																												
_ _ x _	<p>Encoder output pulse setting selection</p> <p>0: Output pulse setting (When "_ 1 0_" is set to this parameter, [AL. 37 Parameter error] will occur.)</p> <p>1: Division ratio setting</p> <p>3: A/B-phase pulse electronic gear setting</p> <p>For linear servo motors, selecting "0" will output as division ratio setting because the output pulse setting is not available.</p>	0h																												
_ x _ _	<p>Selection of the encoders for encoder output pulse</p> <p>This is used for selecting an encoder for servo amplifier output.</p> <p>0: Servo motor encoder</p> <p>1: Load-side encoder</p> <p>Use [Pr. PA16] only in the fully closed loop system.</p> <p>If "1" is set other than in the fully closed loop system, [AL. 37 Parameter error] will occur.</p>	0h																												
x _ _ _	For manufacturer setting	0h																												

5. PARAMETERS

No.	Symbol	Name and function	Initial value [unit]	Setting range	Each/ Common													
PC04	**COP1	Function selection C-1 Select the encoder cable communication method selection. <table border="1" data-bbox="347 405 1155 786"> <thead> <tr> <th>Setting digit</th> <th>Explanation</th> <th>Initial value</th> </tr> </thead> <tbody> <tr> <td>___x</td> <td rowspan="3">For manufacturer setting</td> <td>0h</td> </tr> <tr> <td>__x_</td> <td>0h</td> </tr> <tr> <td>_x__</td> <td>0h</td> </tr> <tr> <td>x___</td> <td>Encoder cable communication method selection 0: Two-wire type 1: Four-wire type Incorrect setting will result in [AL. 16 Encoder initial communication error 1]. Or [AL. 20 Encoder initial communication error 1] will occur. Setting "1" will trigger [AL. 37] while "Fully closed loop control mode (_ _ 1 _)" is selected in [Pr. PA01].</td> <td>0h</td> </tr> </tbody> </table>	Setting digit	Explanation	Initial value	___x	For manufacturer setting	0h	__x_	0h	_x__	0h	x___	Encoder cable communication method selection 0: Two-wire type 1: Four-wire type Incorrect setting will result in [AL. 16 Encoder initial communication error 1]. Or [AL. 20 Encoder initial communication error 1] will occur. Setting "1" will trigger [AL. 37] while "Fully closed loop control mode (_ _ 1 _)" is selected in [Pr. PA01].	0h	Refer to Name and function column.		Each
Setting digit	Explanation	Initial value																
___x	For manufacturer setting	0h																
__x_		0h																
_x__		0h																
x___	Encoder cable communication method selection 0: Two-wire type 1: Four-wire type Incorrect setting will result in [AL. 16 Encoder initial communication error 1]. Or [AL. 20 Encoder initial communication error 1] will occur. Setting "1" will trigger [AL. 37] while "Fully closed loop control mode (_ _ 1 _)" is selected in [Pr. PA01].	0h																
PC05	**COP2	Function selection C-2 This is used to select the motor-less operation. This is not used in linear servo motor control mode, fully closed loop control, and DD motor control mode. <table border="1" data-bbox="347 925 1155 1173"> <thead> <tr> <th>Setting digit</th> <th>Explanation</th> <th>Initial value</th> </tr> </thead> <tbody> <tr> <td>___x</td> <td>Motor-less operation selection 0: Disabled 1: Enabled</td> <td>0h</td> </tr> <tr> <td>__x_</td> <td rowspan="3">For manufacturer setting</td> <td>0h</td> </tr> <tr> <td>_x__</td> <td>0h</td> </tr> <tr> <td>x___</td> <td>0h</td> </tr> </tbody> </table>	Setting digit	Explanation	Initial value	___x	Motor-less operation selection 0: Disabled 1: Enabled	0h	__x_	For manufacturer setting	0h	_x__	0h	x___	0h	Refer to Name and function column.		Each
Setting digit	Explanation	Initial value																
___x	Motor-less operation selection 0: Disabled 1: Enabled	0h																
__x_	For manufacturer setting	0h																
_x__		0h																
x___		0h																
PC06	*COP3	Function selection C-3 Select the error excessive alarm level setting for [Pr. PC01]. The parameter is not available in the speed control mode and torque control mode. <table border="1" data-bbox="347 1312 1155 1621"> <thead> <tr> <th>Setting digit</th> <th>Explanation</th> <th>Initial value</th> </tr> </thead> <tbody> <tr> <td>___x</td> <td rowspan="3">For manufacturer setting</td> <td>0h</td> </tr> <tr> <td>__x_</td> <td>0h</td> </tr> <tr> <td>_x__</td> <td>0h</td> </tr> <tr> <td>x___</td> <td>Error excessive alarm level unit selection 0: Per rev or mm 1: Per 0.1 rev or 0.1 mm 2: Per 0.01 rev or 0.01 mm 3: Per 0.001 rev or 0.001 mm</td> <td>0h</td> </tr> </tbody> </table>	Setting digit	Explanation	Initial value	___x	For manufacturer setting	0h	__x_	0h	_x__	0h	x___	Error excessive alarm level unit selection 0: Per rev or mm 1: Per 0.1 rev or 0.1 mm 2: Per 0.01 rev or 0.01 mm 3: Per 0.001 rev or 0.001 mm	0h	Refer to Name and function column.		Each
Setting digit	Explanation	Initial value																
___x	For manufacturer setting	0h																
__x_		0h																
_x__		0h																
x___	Error excessive alarm level unit selection 0: Per rev or mm 1: Per 0.1 rev or 0.1 mm 2: Per 0.01 rev or 0.01 mm 3: Per 0.001 rev or 0.001 mm	0h																
PC07	ZSP	Zero speed Used to set the output range of ZSP (Zero speed detection). ZSP (Zero speed detection) has hysteresis of 20 r/min or 20 mm/s.	50 [r/min]/ [mm/s]	0 to 10000	Each													
PC08	OSL	Overspeed alarm detection level This is used to set an overspeed alarm detection level. When you set a value more than "(linear) servo motor maximum speed × 120%", the set value will be clamped. When you set "0", the value of "(linear) servo motor maximum speed × 120%" will be set.	0 [r/min]/ [mm/s]	0 to 20000	Each													

5. PARAMETERS

No.	Symbol	Name and function	Initial value [unit]	Setting range	Each/ Common													
PC17	**COP4	Function selection C-4 This is used to select a home position setting condition. <table border="1" data-bbox="347 398 1153 651"> <thead> <tr> <th>Setting digit</th> <th>Explanation</th> <th>Initial value</th> </tr> </thead> <tbody> <tr> <td>___x</td> <td>Selection of home position setting condition 0: Need to pass servo motor Z-phase after power on 1: Not need to pass servo motor Z-phase after power on</td> <td>0h</td> </tr> <tr> <td>__x_</td> <td rowspan="3">For manufacturer setting</td> <td>0h</td> </tr> <tr> <td>_x__</td> <td>0h</td> </tr> <tr> <td>x___</td> <td>0h</td> </tr> </tbody> </table>	Setting digit	Explanation	Initial value	___x	Selection of home position setting condition 0: Need to pass servo motor Z-phase after power on 1: Not need to pass servo motor Z-phase after power on	0h	__x_	For manufacturer setting	0h	_x__	0h	x___	0h	Refer to Name and function column.		Each
Setting digit	Explanation	Initial value																
___x	Selection of home position setting condition 0: Need to pass servo motor Z-phase after power on 1: Not need to pass servo motor Z-phase after power on	0h																
__x_	For manufacturer setting	0h																
_x__		0h																
x___		0h																
PC18	*COP5	Function selection C-5 This is used to select an occurring condition of [AL. E9 Main circuit off warning]. <table border="1" data-bbox="347 763 1153 1016"> <thead> <tr> <th>Setting digit</th> <th>Explanation</th> <th>Initial value</th> </tr> </thead> <tbody> <tr> <td>___x</td> <td rowspan="3">For manufacturer setting</td> <td>0h</td> </tr> <tr> <td>__x_</td> <td>0h</td> </tr> <tr> <td>_x__</td> <td>0h</td> </tr> <tr> <td>x___</td> <td>[AL. E9 Main circuit off warning] selection 0: Detection with ready-on and servo-on command 1: Detection with servo-on command</td> <td>0h</td> </tr> </tbody> </table>	Setting digit	Explanation	Initial value	___x	For manufacturer setting	0h	__x_	0h	_x__	0h	x___	[AL. E9 Main circuit off warning] selection 0: Detection with ready-on and servo-on command 1: Detection with servo-on command	0h	Refer to Name and function column.		Common
Setting digit	Explanation	Initial value																
___x	For manufacturer setting	0h																
__x_		0h																
_x__		0h																
x___	[AL. E9 Main circuit off warning] selection 0: Detection with ready-on and servo-on command 1: Detection with servo-on command	0h																
PC21	*BPS	Alarm history clear Used to clear the alarm history. <table border="1" data-bbox="347 1128 1153 1458"> <thead> <tr> <th>Setting digit</th> <th>Explanation</th> <th>Initial value</th> </tr> </thead> <tbody> <tr> <td>___x</td> <td>Alarm history clear selection 0: Disabled 1: Enabled When you select "Enabled", the alarm history will be cleared at next power-on. After the alarm history is cleared, the setting is automatically disabled.</td> <td>0h</td> </tr> <tr> <td>__x_</td> <td rowspan="3">For manufacturer setting</td> <td>0h</td> </tr> <tr> <td>_x__</td> <td>0h</td> </tr> <tr> <td>x___</td> <td>0h</td> </tr> </tbody> </table>	Setting digit	Explanation	Initial value	___x	Alarm history clear selection 0: Disabled 1: Enabled When you select "Enabled", the alarm history will be cleared at next power-on. After the alarm history is cleared, the setting is automatically disabled.	0h	__x_	For manufacturer setting	0h	_x__	0h	x___	0h	Refer to Name and function column.		Each
Setting digit	Explanation	Initial value																
___x	Alarm history clear selection 0: Disabled 1: Enabled When you select "Enabled", the alarm history will be cleared at next power-on. After the alarm history is cleared, the setting is automatically disabled.	0h																
__x_	For manufacturer setting	0h																
_x__		0h																
x___		0h																

5. PARAMETERS

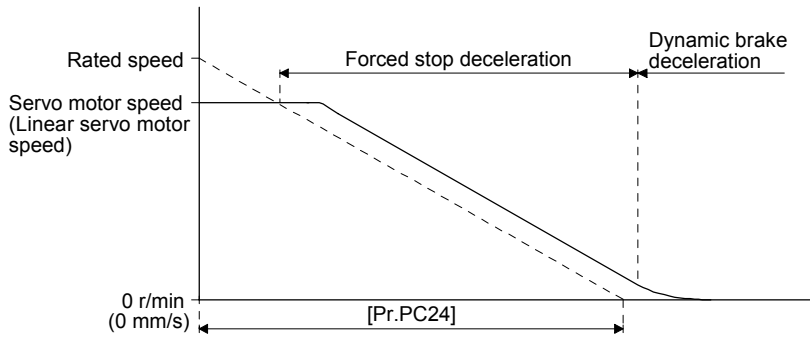
No.	Symbol	Name and function	Initial value [unit]	Setting range	Each/ Common													
PC24	RSBR	<p>Forced stop deceleration time constant</p> <p>This is used to set deceleration time constant when you use the forced stop deceleration function.</p> <p>Set the time per ms from the rated speed to 0 r/min or 0 mm/s.</p>  <p>[Precautions]</p> <ul style="list-style-type: none"> • If the servo motor torque is saturated at the maximum torque during forced stop deceleration because the set time is too short, the time to stop will be longer than the set time constant. • [AL. 50 Overload alarm 1] or [AL. 51 Overload alarm 2] may occur during forced stop deceleration, depending on the set value. • After an alarm that leads to a forced stop deceleration, if an alarm that does not lead to a forced stop deceleration occurs or if the control circuit power supply is cut, dynamic braking will start regardless of the deceleration time constant setting. • Set a longer time than deceleration time of the controller. If a shorter time is set, [AL. 52 Error excessive] may occur. 	100 [ms]	0 to 20000	Each													
PC27	**COP9	<p>Function selection C-9</p> <p>This is used to select a polarity of the linear encoder or load-side encoder.</p> <table border="1" data-bbox="343 1243 1149 1556"> <thead> <tr> <th>Setting digit</th> <th>Explanation</th> <th>Initial value</th> </tr> </thead> <tbody> <tr> <td>___x</td> <td>Selection of encoder pulse count polarity 0: Encoder pulse increasing direction in the servo motor CCW or positive direction 1: Encoder pulse decreasing direction in the servo motor CCW or positive direction</td> <td>0h</td> </tr> <tr> <td>__x_</td> <td rowspan="3">For manufacturer setting</td> <td>0h</td> </tr> <tr> <td>_x__</td> <td>0h</td> </tr> <tr> <td>x___</td> <td>0h</td> </tr> </tbody> </table>	Setting digit	Explanation	Initial value	___x	Selection of encoder pulse count polarity 0: Encoder pulse increasing direction in the servo motor CCW or positive direction 1: Encoder pulse decreasing direction in the servo motor CCW or positive direction	0h	__x_	For manufacturer setting	0h	_x__	0h	x___	0h	Refer to Name and function column.		Each
Setting digit	Explanation	Initial value																
___x	Selection of encoder pulse count polarity 0: Encoder pulse increasing direction in the servo motor CCW or positive direction 1: Encoder pulse decreasing direction in the servo motor CCW or positive direction	0h																
__x_	For manufacturer setting	0h																
_x__		0h																
x___		0h																
PC29	*COPB	<p>Function selection C-B</p> <p>This is used to select the POL reflection at torque control.</p> <table border="1" data-bbox="343 1646 1149 1904"> <thead> <tr> <th>Setting digit</th> <th>Explanation</th> <th>Initial value</th> </tr> </thead> <tbody> <tr> <td>___x</td> <td rowspan="3">For manufacturer setting</td> <td>0h</td> </tr> <tr> <td>__x_</td> <td>0h</td> </tr> <tr> <td>_x__</td> <td>0h</td> </tr> <tr> <td>x___</td> <td>POL reflection selection at torque control 0: Enabled 1: Disabled</td> <td>0h</td> </tr> </tbody> </table>	Setting digit	Explanation	Initial value	___x	For manufacturer setting	0h	__x_	0h	_x__	0h	x___	POL reflection selection at torque control 0: Enabled 1: Disabled	0h	Refer to Name and function column.		Each
Setting digit	Explanation	Initial value																
___x	For manufacturer setting	0h																
__x_		0h																
_x__		0h																
x___	POL reflection selection at torque control 0: Enabled 1: Disabled	0h																

5. PARAMETERS

No.	Symbol	Name and function	Initial value [unit]	Setting range	Each/ Common
PC31	RSUP1	<p>Vertical axis freefall prevention compensation amount</p> <p>Set the compensation amount of the vertical axis freefall prevention function.</p> <p>Set it per servo motor rotation amount.</p> <p>When a positive value is set, compensation is performed to the address increasing direction. When a negative value is set, compensation is performed to the address decreasing direction.</p> <p>The vertical axis freefall prevention function is performed when all of the following conditions are met.</p> <ol style="list-style-type: none"> 1) Position control mode 2) The value of the parameter is other than "0". 3) The forced stop deceleration function is enabled. 4) Alarm occurs or EM2 turns off when the (linear) servo motor speed is zero speed or less. 5) MBR (Electromagnetic brake interlock) was enabled in [Pr. PD07] to [Pr. PD09], and the base circuit shut-off delay time was set in [Pr. PC16]. 	0 [0.0001 rev]/ [0.01 mm]	-25000 to 25000	Each

5.2.4 I/O setting parameters ([Pr. PD__])

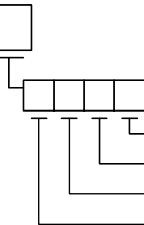
No.	Symbol	Name and function	Initial value [unit]	Setting range	Each/ Common																																										
PD02	*DIA2	<p>Input signal automatic on selection 2</p> <table border="1" style="width: 100%; border-collapse: collapse;"> <thead> <tr> <th colspan="2">Setting digit</th> <th rowspan="2">Explanation</th> <th rowspan="2">Initial value</th> </tr> <tr> <th>HEX.</th> <th>BIN.</th> </tr> </thead> <tbody> <tr> <td>___x</td> <td>___x</td> <td>FLS (Upper stroke limit) selection 0: Disabled 1: Enabled</td> <td rowspan="4">0h</td> </tr> <tr> <td>__x_</td> <td>__x_</td> <td>RLS (Lower stroke limit) selection 0: Disabled 1: Enabled</td> </tr> <tr> <td>_x__</td> <td>_x__</td> <td>For manufacturer setting</td> </tr> <tr> <td>x___</td> <td>x___</td> <td>For manufacturer setting</td> </tr> <tr> <td>__x_</td> <td>/</td> <td rowspan="3">For manufacturer setting</td> <td>0h</td> </tr> <tr> <td>_x__</td> <td>/</td> <td>0h</td> </tr> <tr> <td>x___</td> <td>/</td> <td>0h</td> </tr> </tbody> </table> <p>Convert the setting value into hexadecimal as follows.</p> <div style="display: flex; align-items: center; margin-top: 10px;"> <div style="border: 1px solid black; padding: 2px; margin-right: 10px;">0 0 0</div>  <table border="1" style="margin-left: 20px;"> <thead> <tr> <th rowspan="2">Signal name</th> <th colspan="2">Initial value</th> </tr> <tr> <th>BIN</th> <th>HEX</th> </tr> </thead> <tbody> <tr> <td>FLS (Upper stroke limit) selection</td> <td>0</td> <td rowspan="4">0</td> </tr> <tr> <td>RLS (Lower stroke limit) selection</td> <td>0</td> </tr> <tr> <td></td> <td>0</td> </tr> <tr> <td></td> <td>0</td> </tr> </tbody> </table> </div> <p style="margin-top: 5px;">BIN 0: Disabled (Use for an external input signal.) BIN 1: Automatic on</p>	Setting digit		Explanation	Initial value	HEX.	BIN.	___x	___x	FLS (Upper stroke limit) selection 0: Disabled 1: Enabled	0h	__x_	__x_	RLS (Lower stroke limit) selection 0: Disabled 1: Enabled	_x__	_x__	For manufacturer setting	x___	x___	For manufacturer setting	__x_	/	For manufacturer setting	0h	_x__	/	0h	x___	/	0h	Signal name	Initial value		BIN	HEX	FLS (Upper stroke limit) selection	0	0	RLS (Lower stroke limit) selection	0		0		0	Refer to Name and function column.	Each
Setting digit		Explanation	Initial value																																												
HEX.	BIN.																																														
___x	___x	FLS (Upper stroke limit) selection 0: Disabled 1: Enabled	0h																																												
__x_	__x_	RLS (Lower stroke limit) selection 0: Disabled 1: Enabled																																													
_x__	_x__	For manufacturer setting																																													
x___	x___	For manufacturer setting																																													
__x_	/	For manufacturer setting	0h																																												
_x__	/		0h																																												
x___	/		0h																																												
Signal name	Initial value																																														
	BIN	HEX																																													
FLS (Upper stroke limit) selection	0	0																																													
RLS (Lower stroke limit) selection	0																																														
	0																																														
	0																																														

5. PARAMETERS

No.	Symbol	Name and function	Initial value [unit]	Setting range	Each/ Common																																										
PD07	*DO1	<p>Output device selection 1</p> <p>You can assign any output device to pins CN3-12, CN3-13, and CN3-25. In the initial setting, the following devices are assigned to the pins.</p> <p>CN3-12 pin: MBR-A (Electromagnetic brake interlock for A-axis)</p> <p>CN3-13 pin: MBR-C (Electromagnetic brake interlock for C-axis)</p> <p>CN3-25 pin: MBR-B (Electromagnetic brake interlock for B-axis)</p> <table border="1"> <thead> <tr> <th>Setting digit</th> <th>Explanation</th> <th>Initial value</th> </tr> </thead> <tbody> <tr> <td>__ x x</td> <td>Device selection Refer to table 5.7 for settings.</td> <td>05h</td> </tr> <tr> <td>_ x _ _</td> <td>For manufacturer setting</td> <td>0h</td> </tr> <tr> <td>x _ _ _</td> <td></td> <td>0h</td> </tr> </tbody> </table> <p style="text-align: center;">Table 5.7 Selectable output devices</p> <table border="1"> <thead> <tr> <th>Setting value</th> <th>Output device</th> </tr> </thead> <tbody> <tr><td>00</td><td>Always off</td></tr> <tr><td>02</td><td>RD (Ready)</td></tr> <tr><td>03</td><td>ALM (Malfunction)</td></tr> <tr><td>04</td><td>INP (In-position)</td></tr> <tr><td>05</td><td>MBR (Electromagnetic brake interlock)</td></tr> <tr><td>07</td><td>TLC (Limiting torque)</td></tr> <tr><td>08</td><td>WNG (Warning)</td></tr> <tr><td>09</td><td>BWNG (Battery warning)</td></tr> <tr><td>0A</td><td>SA (Speed reached)</td></tr> <tr><td>0C</td><td>ZSP (Zero speed detection)</td></tr> <tr><td>0F</td><td>CDPS (Variable gain selection)</td></tr> <tr><td>10</td><td>CLDS (During fully closed loop control)</td></tr> <tr><td>11</td><td>ABSV (Absolute position undetermined)</td></tr> <tr><td>17</td><td>MTTR (During tough drive)</td></tr> </tbody> </table>	Setting digit	Explanation	Initial value	__ x x	Device selection Refer to table 5.7 for settings.	05h	_ x _ _	For manufacturer setting	0h	x _ _ _		0h	Setting value	Output device	00	Always off	02	RD (Ready)	03	ALM (Malfunction)	04	INP (In-position)	05	MBR (Electromagnetic brake interlock)	07	TLC (Limiting torque)	08	WNG (Warning)	09	BWNG (Battery warning)	0A	SA (Speed reached)	0C	ZSP (Zero speed detection)	0F	CDPS (Variable gain selection)	10	CLDS (During fully closed loop control)	11	ABSV (Absolute position undetermined)	17	MTTR (During tough drive)	Refer to Name and function column.		Each
Setting digit	Explanation	Initial value																																													
__ x x	Device selection Refer to table 5.7 for settings.	05h																																													
_ x _ _	For manufacturer setting	0h																																													
x _ _ _		0h																																													
Setting value	Output device																																														
00	Always off																																														
02	RD (Ready)																																														
03	ALM (Malfunction)																																														
04	INP (In-position)																																														
05	MBR (Electromagnetic brake interlock)																																														
07	TLC (Limiting torque)																																														
08	WNG (Warning)																																														
09	BWNG (Battery warning)																																														
0A	SA (Speed reached)																																														
0C	ZSP (Zero speed detection)																																														
0F	CDPS (Variable gain selection)																																														
10	CLDS (During fully closed loop control)																																														
11	ABSV (Absolute position undetermined)																																														
17	MTTR (During tough drive)																																														
PD08	*DO2	<p>Output device selection 2</p> <p>You can assign any output device to the CN3-24 pin for each axis. C INP (AND in-position) is assigned to the all axes in the initial setting.</p> <p>The devices that can be assigned and the setting method are the same as in [Pr. PD07].</p> <table border="1"> <thead> <tr> <th>Setting digit</th> <th>Explanation</th> <th>Initial value</th> </tr> </thead> <tbody> <tr> <td>__ x x</td> <td>Device selection Refer to table 5.7 in [Pr. PD07] for settings.</td> <td>04h</td> </tr> <tr> <td>_ x _ _</td> <td>All-axis output condition selection 0: AND output When all axes of A, B, and C meet a condition, the device will be enabled (on or off). 1: OR output When each axis of A, B, or C meet a condition, the device will be enabled (on or off). The digit will be enabled when "All axes (0 __ _)" is selected.</td> <td>0h</td> </tr> <tr> <td>x _ _ _</td> <td>Output axis selection 0: All axes 1: A-axis 2: B-axis 3: C-axis</td> <td>0h</td> </tr> </tbody> </table>	Setting digit	Explanation	Initial value	__ x x	Device selection Refer to table 5.7 in [Pr. PD07] for settings.	04h	_ x _ _	All-axis output condition selection 0: AND output When all axes of A, B, and C meet a condition, the device will be enabled (on or off). 1: OR output When each axis of A, B, or C meet a condition, the device will be enabled (on or off). The digit will be enabled when "All axes (0 __ _)" is selected.	0h	x _ _ _	Output axis selection 0: All axes 1: A-axis 2: B-axis 3: C-axis	0h	Refer to Name and function column.		Common																														
Setting digit	Explanation	Initial value																																													
__ x x	Device selection Refer to table 5.7 in [Pr. PD07] for settings.	04h																																													
_ x _ _	All-axis output condition selection 0: AND output When all axes of A, B, and C meet a condition, the device will be enabled (on or off). 1: OR output When each axis of A, B, or C meet a condition, the device will be enabled (on or off). The digit will be enabled when "All axes (0 __ _)" is selected.	0h																																													
x _ _ _	Output axis selection 0: All axes 1: A-axis 2: B-axis 3: C-axis	0h																																													

5. PARAMETERS

No.	Symbol	Name and function	Initial value [unit]	Setting range	Each/ Common													
PD09	*DO3	<p>Output device selection 3</p> <p>You can assign any output device to the CN3-11 pin for each axis. CALM (AND malfunction) is assigned to the all axes in the initial setting.</p> <p>The devices that can be assigned and the setting method are the same as in [Pr. PD07].</p> <table border="1"> <thead> <tr> <th>Setting digit</th> <th>Explanation</th> <th>Initial value</th> </tr> </thead> <tbody> <tr> <td>__ x x</td> <td>Device selection Refer to table 5.7 in [Pr. PD07] for settings.</td> <td>03h</td> </tr> <tr> <td>_ x __</td> <td>All-axis output condition selection 0: AND output When all axes of A, B, and C meet a condition, the device will be enabled (on or off). 1: OR output When each axis of A, B, or C meet a condition, the device will be enabled (on or off). The digit will be enabled when "All axes (0 __ __)" is selected.</td> <td>0h</td> </tr> <tr> <td>x ___</td> <td>Output axis selection 0: All axes 1: A-axis 2: B-axis 3: C-axis</td> <td>0h</td> </tr> </tbody> </table>	Setting digit	Explanation	Initial value	__ x x	Device selection Refer to table 5.7 in [Pr. PD07] for settings.	03h	_ x __	All-axis output condition selection 0: AND output When all axes of A, B, and C meet a condition, the device will be enabled (on or off). 1: OR output When each axis of A, B, or C meet a condition, the device will be enabled (on or off). The digit will be enabled when "All axes (0 __ __)" is selected.	0h	x ___	Output axis selection 0: All axes 1: A-axis 2: B-axis 3: C-axis	0h	Refer to Name and function column.		Common	
Setting digit	Explanation	Initial value																
__ x x	Device selection Refer to table 5.7 in [Pr. PD07] for settings.	03h																
_ x __	All-axis output condition selection 0: AND output When all axes of A, B, and C meet a condition, the device will be enabled (on or off). 1: OR output When each axis of A, B, or C meet a condition, the device will be enabled (on or off). The digit will be enabled when "All axes (0 __ __)" is selected.	0h																
x ___	Output axis selection 0: All axes 1: A-axis 2: B-axis 3: C-axis	0h																
PD12	*DOP1	<p>Function selection D-1</p> <table border="1"> <thead> <tr> <th>Setting digit</th> <th>Explanation</th> <th>Initial value</th> </tr> </thead> <tbody> <tr> <td>___ x</td> <td rowspan="3">For manufacturer setting</td> <td>0h</td> </tr> <tr> <td>__ x _</td> <td>0h</td> </tr> <tr> <td>_ x __</td> <td>0h</td> </tr> <tr> <td>x ___</td> <td>Servo motor or linear servo motor thermistor enabled/ disabled selection (Supported by servo amplifiers with software version A5 or above.) 0: Enabled 1: Disabled For servo motors or linear servo motor without thermistor, the setting will be disabled.</td> <td>0h</td> </tr> </tbody> </table>	Setting digit	Explanation	Initial value	___ x	For manufacturer setting	0h	__ x _	0h	_ x __	0h	x ___	Servo motor or linear servo motor thermistor enabled/ disabled selection (Supported by servo amplifiers with software version A5 or above.) 0: Enabled 1: Disabled For servo motors or linear servo motor without thermistor, the setting will be disabled.	0h	Refer to Name and function column.		Each
Setting digit	Explanation	Initial value																
___ x	For manufacturer setting	0h																
__ x _		0h																
_ x __		0h																
x ___	Servo motor or linear servo motor thermistor enabled/ disabled selection (Supported by servo amplifiers with software version A5 or above.) 0: Enabled 1: Disabled For servo motors or linear servo motor without thermistor, the setting will be disabled.	0h																

5. PARAMETERS

No.	Symbol	Name and function	Initial value [unit]	Setting range	Each/ Common																																												
PD14	*DOP3	Function selection D-3			Each																																												
		<table border="1"> <thead> <tr> <th>Setting digit</th> <th>Explanation</th> <th>Initial value</th> </tr> </thead> <tbody> <tr> <td>___x</td> <td>For manufacturer setting</td> <td>0h</td> </tr> <tr> <td>__x_</td> <td>Selection of output device at warning occurrence Select WNG (Warning) and ALM (Malfunction) output status at warning occurrence.</td> <td>0h</td> </tr> <tr> <td></td> <td>Servo amplifier output</td> <td></td> </tr> <tr> <td></td> <td> <table border="1"> <thead> <tr> <th>Setting value</th> <th>(Note 1) Device status</th> </tr> </thead> <tbody> <tr> <td>0</td> <td> <p>WNG 1 0 ALM 1 0 Warning occurrence</p> </td> </tr> <tr> <td>1</td> <td> <p>WNG 1 0 ALM 1 0 Warning occurrence (Note 2)</p> </td> </tr> </tbody> </table> </td> <td></td> </tr> <tr> <td></td> <td></td> <td>Note 1. 0: Off 1: On</td> <td></td> <td></td> <td></td> </tr> <tr> <td></td> <td></td> <td>2. Although ALM is turned off upon occurrence of the warning, the forced stop deceleration is performed.</td> <td></td> <td></td> <td></td> </tr> <tr> <td></td> <td></td> <td>___x__</td> <td>For manufacturer setting</td> <td>0h</td> <td></td> </tr> <tr> <td></td> <td></td> <td>x___</td> <td></td> <td>0h</td> <td></td> </tr> </tbody> </table>	Setting digit	Explanation	Initial value	___x	For manufacturer setting	0h	__x_	Selection of output device at warning occurrence Select WNG (Warning) and ALM (Malfunction) output status at warning occurrence.	0h		Servo amplifier output			<table border="1"> <thead> <tr> <th>Setting value</th> <th>(Note 1) Device status</th> </tr> </thead> <tbody> <tr> <td>0</td> <td> <p>WNG 1 0 ALM 1 0 Warning occurrence</p> </td> </tr> <tr> <td>1</td> <td> <p>WNG 1 0 ALM 1 0 Warning occurrence (Note 2)</p> </td> </tr> </tbody> </table>	Setting value	(Note 1) Device status	0	<p>WNG 1 0 ALM 1 0 Warning occurrence</p>	1	<p>WNG 1 0 ALM 1 0 Warning occurrence (Note 2)</p>				Note 1. 0: Off 1: On						2. Although ALM is turned off upon occurrence of the warning, the forced stop deceleration is performed.						___x__	For manufacturer setting	0h				x___		0h		Refer to Name and function column.	
Setting digit	Explanation	Initial value																																															
___x	For manufacturer setting	0h																																															
__x_	Selection of output device at warning occurrence Select WNG (Warning) and ALM (Malfunction) output status at warning occurrence.	0h																																															
	Servo amplifier output																																																
	<table border="1"> <thead> <tr> <th>Setting value</th> <th>(Note 1) Device status</th> </tr> </thead> <tbody> <tr> <td>0</td> <td> <p>WNG 1 0 ALM 1 0 Warning occurrence</p> </td> </tr> <tr> <td>1</td> <td> <p>WNG 1 0 ALM 1 0 Warning occurrence (Note 2)</p> </td> </tr> </tbody> </table>	Setting value	(Note 1) Device status	0	<p>WNG 1 0 ALM 1 0 Warning occurrence</p>	1	<p>WNG 1 0 ALM 1 0 Warning occurrence (Note 2)</p>																																										
Setting value	(Note 1) Device status																																																
0	<p>WNG 1 0 ALM 1 0 Warning occurrence</p>																																																
1	<p>WNG 1 0 ALM 1 0 Warning occurrence (Note 2)</p>																																																
		Note 1. 0: Off 1: On																																															
		2. Although ALM is turned off upon occurrence of the warning, the forced stop deceleration is performed.																																															
		___x__	For manufacturer setting	0h																																													
		x___		0h																																													

5. PARAMETERS

5.2.5 Extension setting 2 parameters ([Pr. PE_ _])

No.	Symbol	Name and function	Initial value [unit]	Setting range	Each/ Common																					
PE01	**FCT1	Fully closed loop function selection 1	Refer to Name and function column.		Each																					
		<table border="1"> <thead> <tr> <th>Setting digit</th> <th>Explanation</th> <th>Initial value</th> </tr> </thead> <tbody> <tr> <td>___x</td> <td>Fully closed loop function selection 0: Always enabled 1: Switching with the control command of controller (switching semi./full.) <table border="1"> <thead> <tr> <th>Switching with the control command of controller</th> <th>Control system</th> </tr> </thead> <tbody> <tr> <td>Off</td> <td>Semi closed loop control</td> </tr> <tr> <td>On</td> <td>Fully closed loop control</td> </tr> </tbody> </table> To enable the digit, select "Fully closed loop control mode (_ 1 _)" of "operation mode selection" in [Pr. PA01]. </td> <td>0h</td> </tr> <tr> <td>__x_</td> <td>For manufacturer setting</td> <td>0h</td> </tr> <tr> <td>_x__</td> <td></td> <td>0h</td> </tr> <tr> <td>x___</td> <td></td> <td>0h</td> </tr> </tbody> </table>				Setting digit	Explanation	Initial value	___x	Fully closed loop function selection 0: Always enabled 1: Switching with the control command of controller (switching semi./full.) <table border="1"> <thead> <tr> <th>Switching with the control command of controller</th> <th>Control system</th> </tr> </thead> <tbody> <tr> <td>Off</td> <td>Semi closed loop control</td> </tr> <tr> <td>On</td> <td>Fully closed loop control</td> </tr> </tbody> </table> To enable the digit, select "Fully closed loop control mode (_ 1 _)" of "operation mode selection" in [Pr. PA01].	Switching with the control command of controller	Control system	Off	Semi closed loop control	On	Fully closed loop control	0h	__x_	For manufacturer setting	0h	_x__		0h	x___		0h
		Setting digit				Explanation	Initial value																			
		___x				Fully closed loop function selection 0: Always enabled 1: Switching with the control command of controller (switching semi./full.) <table border="1"> <thead> <tr> <th>Switching with the control command of controller</th> <th>Control system</th> </tr> </thead> <tbody> <tr> <td>Off</td> <td>Semi closed loop control</td> </tr> <tr> <td>On</td> <td>Fully closed loop control</td> </tr> </tbody> </table> To enable the digit, select "Fully closed loop control mode (_ 1 _)" of "operation mode selection" in [Pr. PA01].	Switching with the control command of controller	Control system	Off	Semi closed loop control	On	Fully closed loop control	0h													
Switching with the control command of controller	Control system																									
Off	Semi closed loop control																									
On	Fully closed loop control																									
__x_	For manufacturer setting	0h																								
_x__		0h																								
x___		0h																								
PE03	*FCT2	Fully closed loop function selection 2	Refer to Name and function column.		Each																					
		<table border="1"> <thead> <tr> <th>Setting digit</th> <th>Explanation</th> <th>Initial value</th> </tr> </thead> <tbody> <tr> <td>___x</td> <td>Fully closed loop control error detection function selection 0: Disabled 1: Speed deviation error detection 2: Position deviation error detection 3: Speed deviation error/position deviation error detection</td> <td>3h</td> </tr> <tr> <td>__x_</td> <td>Position deviation error detection system selection 0: Continuous detection system 1: Detection system at stop (detected with command set to "0")</td> <td>0h</td> </tr> <tr> <td>_x__</td> <td>For manufacturer setting</td> <td>0h</td> </tr> <tr> <td>x___</td> <td>Fully closed loop control error reset selection 0: Reset disabled (reset by powering off/on enabled) 1: Reset enabled</td> <td>0h</td> </tr> </tbody> </table>				Setting digit	Explanation	Initial value	___x	Fully closed loop control error detection function selection 0: Disabled 1: Speed deviation error detection 2: Position deviation error detection 3: Speed deviation error/position deviation error detection	3h	__x_	Position deviation error detection system selection 0: Continuous detection system 1: Detection system at stop (detected with command set to "0")	0h	_x__	For manufacturer setting	0h	x___	Fully closed loop control error reset selection 0: Reset disabled (reset by powering off/on enabled) 1: Reset enabled	0h						
		Setting digit				Explanation	Initial value																			
		___x				Fully closed loop control error detection function selection 0: Disabled 1: Speed deviation error detection 2: Position deviation error detection 3: Speed deviation error/position deviation error detection	3h																			
__x_	Position deviation error detection system selection 0: Continuous detection system 1: Detection system at stop (detected with command set to "0")	0h																								
_x__	For manufacturer setting	0h																								
x___	Fully closed loop control error reset selection 0: Reset disabled (reset by powering off/on enabled) 1: Reset enabled	0h																								
PE04	**FBN	Fully closed loop control - Feedback pulse electronic gear 1 - Numerator This is used to set a numerator of electronic gear for the servo motor encoder pulse at the fully closed loop control. Set the electronic gear so that the number of servo motor encoder pulses for one servo motor revolution is converted to the resolution of the load-side encoder.	1	1 to 65535	Each																					
PE05	**FBD	Fully closed loop control - Feedback pulse electronic gear 1 - Denominator This is used to set a denominator of electronic gear for the servo motor encoder pulse at the fully closed loop control. Set the electronic gear so that the number of servo motor encoder pulses for one servo motor revolution is converted to the resolution of the load-side encoder.	1	1 to 65535	Each																					
PE06	BC1	Fully closed loop control - Speed deviation error detection level This is used to set [AL. 42.9 Fully closed loop control error by speed deviation] of. When the speed deviation between the servo motor encoder and load-side encoder becomes larger than the setting value, the alarm will occur.	400 [r/min]	1 to 50000	Each																					

5. PARAMETERS

No.	Symbol	Name and function	Initial value [unit]	Setting range	Each/ Common															
PE07	BC2	Fully closed loop control - Position deviation error detection level This is used to set [AL. 42.8 Fully closed loop control error by position deviation] of the fully closed loop control error detection. When the position deviation between the servo motor encoder and load-side encoder becomes larger than the setting value, the alarm will occur.	100 [kpulse]	1 to 20000	Each															
PE08	DUF	Fully closed loop dual feedback filter This is used to set a dual feedback filter band. Refer to section 16.3.1 (5) for details.	[rad/s]	0 to 4500	Each															
PE10	FCT3	Fully closed loop function selection 3 <table border="1" style="width: 100%; border-collapse: collapse;"> <thead> <tr> <th>Setting digit</th> <th>Explanation</th> <th>Initial value</th> </tr> </thead> <tbody> <tr> <td>___x</td> <td>For manufacturer setting</td> <td>0h</td> </tr> <tr> <td>__x_</td> <td>Fully closed loop control - Position deviation error detection level - Unit selection 0: 1 kpulse unit 1: 1 pulse unit</td> <td>0h</td> </tr> <tr> <td>_x__</td> <td>Droop pulse monitor selection for controller display 0: Servo motor encoder 1: Load-side encoder 2: Deviation between the servo motor and load side</td> <td>0h</td> </tr> <tr> <td>x___</td> <td>Cumulative feedback pulses monitor selection for controller display 0: Servo motor encoder 1: Load-side encoder</td> <td>0h</td> </tr> </tbody> </table>	Setting digit	Explanation	Initial value	___x	For manufacturer setting	0h	__x_	Fully closed loop control - Position deviation error detection level - Unit selection 0: 1 kpulse unit 1: 1 pulse unit	0h	_x__	Droop pulse monitor selection for controller display 0: Servo motor encoder 1: Load-side encoder 2: Deviation between the servo motor and load side	0h	x___	Cumulative feedback pulses monitor selection for controller display 0: Servo motor encoder 1: Load-side encoder	0h	Refer to Name and function column.		Each
Setting digit	Explanation	Initial value																		
___x	For manufacturer setting	0h																		
__x_	Fully closed loop control - Position deviation error detection level - Unit selection 0: 1 kpulse unit 1: 1 pulse unit	0h																		
_x__	Droop pulse monitor selection for controller display 0: Servo motor encoder 1: Load-side encoder 2: Deviation between the servo motor and load side	0h																		
x___	Cumulative feedback pulses monitor selection for controller display 0: Servo motor encoder 1: Load-side encoder	0h																		
PE34	**FBN2	Fully closed loop control - Feedback pulse electronic gear 2 - Numerator This is used to set a numerator of electronic gear for the servo motor encoder pulse at the fully closed loop control. Set the electronic gear so that the number of servo motor encoder pulses for one servo motor revolution is converted to the resolution of the load-side encoder. Refer to section 16.3.1 (3) for details.	1	1 to 65535	Each															
PE35	**FBD2	Fully closed loop control - Feedback pulse electronic gear 2 - Denominator This is used to set a denominator of electronic gear for the servo motor encoder pulse at the fully closed loop control. Set the electronic gear so that the number of servo motor encoder pulses for one servo motor revolution is converted to the resolution of the load-side encoder. Refer to section 16.3.1 (3) for details.	1	1 to 65535	Each															
PE41	EOP3	Function selection E-3 <table border="1" style="width: 100%; border-collapse: collapse;"> <thead> <tr> <th>Setting digit</th> <th>Explanation</th> <th>Initial value</th> </tr> </thead> <tbody> <tr> <td>___x</td> <td>Robust filter selection 0: Disabled 1: Enabled When you select "Enabled" of this digit, the machine resonance suppression filter 5 set in [Pr. PB51] is not available.</td> <td>0h</td> </tr> <tr> <td>__x_</td> <td rowspan="3">For manufacturer setting</td> <td>0h</td> </tr> <tr> <td>_x__</td> <td>0h</td> </tr> <tr> <td>x___</td> <td>0h</td> </tr> </tbody> </table>	Setting digit	Explanation	Initial value	___x	Robust filter selection 0: Disabled 1: Enabled When you select "Enabled" of this digit, the machine resonance suppression filter 5 set in [Pr. PB51] is not available.	0h	__x_	For manufacturer setting	0h	_x__	0h	x___	0h	Refer to Name and function column.		Each		
Setting digit	Explanation	Initial value																		
___x	Robust filter selection 0: Disabled 1: Enabled When you select "Enabled" of this digit, the machine resonance suppression filter 5 set in [Pr. PB51] is not available.	0h																		
__x_	For manufacturer setting	0h																		
_x__		0h																		
x___		0h																		

5. PARAMETERS

5.2.6 Extension setting 3 parameters ([Pr. PF__])

No.	Symbol	Name and function	Initial value [unit]	Setting range	Each/ Common												
PF02	*FOP2	Function selection F-2 This is used to set targets of [AL. EB The other axis error warning]. <table border="1" style="width: 100%; border-collapse: collapse;"> <thead> <tr> <th style="width: 15%;">Setting digit</th> <th style="width: 65%;">Explanation</th> <th style="width: 20%;">Initial value</th> </tr> </thead> <tbody> <tr> <td>___x</td> <td> Target alarm selection of the other axis error warning Select target alarms of the other axis error warning. 0: [AL. 24 Main circuit error] and [AL. 32 Overcurrent] 1: All alarms For alarms occurring at all axes, [AL. EB The other axis error warning] will not occur regardless of alarm No. </td> <td>0h</td> </tr> <tr> <td>__x_</td> <td rowspan="3">For manufacturer setting</td> <td>0h</td> </tr> <tr> <td>_x__</td> <td>0h</td> </tr> <tr> <td>x___</td> <td>0h</td> </tr> </tbody> </table>	Setting digit	Explanation	Initial value	___x	Target alarm selection of the other axis error warning Select target alarms of the other axis error warning. 0: [AL. 24 Main circuit error] and [AL. 32 Overcurrent] 1: All alarms For alarms occurring at all axes, [AL. EB The other axis error warning] will not occur regardless of alarm No.	0h	__x_	For manufacturer setting	0h	_x__	0h	x___	0h	Refer to Name and function column.	Common
Setting digit	Explanation	Initial value															
___x	Target alarm selection of the other axis error warning Select target alarms of the other axis error warning. 0: [AL. 24 Main circuit error] and [AL. 32 Overcurrent] 1: All alarms For alarms occurring at all axes, [AL. EB The other axis error warning] will not occur regardless of alarm No.	0h															
__x_	For manufacturer setting	0h															
_x__		0h															
x___		0h															
PF06	*FOP5	Function selection F-5 <table border="1" style="width: 100%; border-collapse: collapse;"> <thead> <tr> <th style="width: 15%;">Setting digit</th> <th style="width: 65%;">Explanation</th> <th style="width: 20%;">Initial value</th> </tr> </thead> <tbody> <tr> <td>___x</td> <td> Electronic dynamic brake selection 0: Automatic (enabled only for specified servo motors) 2: Disabled Refer to the following table for the specified servo motors. </td> <td>0h</td> </tr> <tr> <td>__x_</td> <td rowspan="3">For manufacturer setting</td> <td>0h</td> </tr> <tr> <td>_x__</td> <td>0h</td> </tr> <tr> <td>x___</td> <td>0h</td> </tr> </tbody> </table>	Setting digit	Explanation	Initial value	___x	Electronic dynamic brake selection 0: Automatic (enabled only for specified servo motors) 2: Disabled Refer to the following table for the specified servo motors.	0h	__x_	For manufacturer setting	0h	_x__	0h	x___	0h	Refer to Name and function column.	Each
Setting digit	Explanation	Initial value															
___x	Electronic dynamic brake selection 0: Automatic (enabled only for specified servo motors) 2: Disabled Refer to the following table for the specified servo motors.	0h															
__x_	For manufacturer setting	0h															
_x__		0h															
x___		0h															
PF12	DBT	Electronic dynamic brake operating time Set a operating time for the electronic dynamic brake.	2000 [ms]	0 to 10000	Each												
PF21	DRT	Drive recorder switching time setting This is used to set a drive recorder switching time. When a USB communication is cut during using a graph function, the function will be changed to the drive recorder function after the setting time of this parameter. When a value from "1" to "32767" is set, it will switch after the setting value. However, when "0" is set, it will switch after 600 seconds. When "-1" is set, the drive recorder function is disabled.	0 [s]	-1 to 32767	Common												
PF23	OSCL1	Vibration tough drive - Oscillation detection level This is used to set a filter readjustment sensitivity of [Pr. PB13 Machine resonance suppression filter 1] and [Pr. PB15 Machine resonance suppression filter 2] while the vibration tough drive is enabled. Example: When you set "50" to the parameter, the filter will be readjusted at the time of 50% or more oscillation level.	50 [%]	0 to 100	Each												

5. PARAMETERS

No.	Symbol	Name and function	Initial value [unit]	Setting range	Each/ Common															
PF24	*OSCL2	Vibration tough drive function selection <table border="1" style="width: 100%; border-collapse: collapse;"> <thead> <tr> <th style="width: 15%;">Setting digit</th> <th style="width: 65%;">Explanation</th> <th style="width: 20%;">Initial value</th> </tr> </thead> <tbody> <tr> <td>___x</td> <td> Oscillation detection alarm selection 0: [AL. 54 Oscillation detection] will occur at oscillation detection. 1: [AL. F3.1 Oscillation detection warning] will occur at oscillation detection. 2: Oscillation detection function disabled Select alarm or warning when a oscillation continues at a filter readjustment sensitivity level of [Pr. PF23]. The digit is continuously enabled regardless of the vibration tough drive in [Pr. PA20]. </td> <td>0h</td> </tr> <tr> <td>__x_</td> <td>For manufacturer setting</td> <td>0h</td> </tr> <tr> <td>_x__</td> <td></td> <td>0h</td> </tr> <tr> <td>x__</td> <td></td> <td>0h</td> </tr> </tbody> </table>	Setting digit	Explanation	Initial value	___x	Oscillation detection alarm selection 0: [AL. 54 Oscillation detection] will occur at oscillation detection. 1: [AL. F3.1 Oscillation detection warning] will occur at oscillation detection. 2: Oscillation detection function disabled Select alarm or warning when a oscillation continues at a filter readjustment sensitivity level of [Pr. PF23]. The digit is continuously enabled regardless of the vibration tough drive in [Pr. PA20].	0h	__x_	For manufacturer setting	0h	_x__		0h	x__		0h	Refer to Name and function column.		Each
Setting digit	Explanation	Initial value																		
___x	Oscillation detection alarm selection 0: [AL. 54 Oscillation detection] will occur at oscillation detection. 1: [AL. F3.1 Oscillation detection warning] will occur at oscillation detection. 2: Oscillation detection function disabled Select alarm or warning when a oscillation continues at a filter readjustment sensitivity level of [Pr. PF23]. The digit is continuously enabled regardless of the vibration tough drive in [Pr. PA20].	0h																		
__x_	For manufacturer setting	0h																		
_x__		0h																		
x__		0h																		
PF25	CVAT	SEMI-F47 function - Instantaneous power failure detection time (instantaneous power failure tough drive - detection time) Set the time of the [AL. 10.1 Voltage drop in the control circuit power] occurrence. To disable the parameter, select "Disabled (_ 0 _)" of "SEMI-F47 function selection (instantaneous power failure tough drive selection)" in [Pr. PA20].	200 [ms]	30 to 200	Common															
PF31	FRIC	Machine diagnosis function - Friction judgement speed Set a motor speed to divide a friction estimation area into high and low for the friction estimation process of the machine diagnosis. However, setting "0" will be the value half of the rated speed. When your operation pattern is under rated speed, we recommend that you set half value to the maximum speed with this. <div style="text-align: center;"> </div>	0 [r/min]	0 to permissible speed	Each															

5. PARAMETERS

5.2.7 Linear servo motor/DD motor setting parameters ([Pr. PL_ _])

No.	Symbol	Name and function	Initial value [unit]	Setting range	Each/ Common															
PL01	**LIT1	Linear servo motor/DD motor function selection 1 Select a magnetic pole detection timing of the linear servo motor/DD motor and stop interval of the home position returning.	Refer to Name and function column.		Each															
		<table border="1"> <thead> <tr> <th>Setting digit</th> <th>Explanation</th> <th>Initial value</th> </tr> </thead> <tbody> <tr> <td>___x</td> <td>Linear servo motor/DD motor magnetic pole detection selection The setting value "0" will be enabled only with absolute position linear encoders. 0: Magnetic pole detection disabled 1: Magnetic pole detection at first servo-on 5: Magnetic pole detection at every servo-on</td> <td>1h</td> </tr> <tr> <td>__x_</td> <td>For manufacturer setting</td> <td>0h</td> </tr> <tr> <td>_x__</td> <td>Stop interval selection at the home position return Set a stop interval of the home position returning. The digit is enabled only for linear servo motors. 0: 2^{13} (= 8192) pulses 1: 2^{17} (= 131072) pulses 2: 2^{18} (= 262144) pulses 3: 2^{20} (= 1048576) pulses 4: 2^{22} (= 4194304) pulses 5: 2^{24} (= 16777216) pulses 6: 2^{26} (= 67108864) pulses</td> <td>3h</td> </tr> <tr> <td>x___</td> <td>For manufacturer setting</td> <td>0h</td> </tr> </tbody> </table>				Setting digit	Explanation	Initial value	___x	Linear servo motor/DD motor magnetic pole detection selection The setting value "0" will be enabled only with absolute position linear encoders. 0: Magnetic pole detection disabled 1: Magnetic pole detection at first servo-on 5: Magnetic pole detection at every servo-on	1h	__x_	For manufacturer setting	0h	_x__	Stop interval selection at the home position return Set a stop interval of the home position returning. The digit is enabled only for linear servo motors. 0: 2^{13} (= 8192) pulses 1: 2^{17} (= 131072) pulses 2: 2^{18} (= 262144) pulses 3: 2^{20} (= 1048576) pulses 4: 2^{22} (= 4194304) pulses 5: 2^{24} (= 16777216) pulses 6: 2^{26} (= 67108864) pulses	3h	x___	For manufacturer setting	0h
		Setting digit				Explanation	Initial value													
		___x				Linear servo motor/DD motor magnetic pole detection selection The setting value "0" will be enabled only with absolute position linear encoders. 0: Magnetic pole detection disabled 1: Magnetic pole detection at first servo-on 5: Magnetic pole detection at every servo-on	1h													
		__x_				For manufacturer setting	0h													
_x__	Stop interval selection at the home position return Set a stop interval of the home position returning. The digit is enabled only for linear servo motors. 0: 2^{13} (= 8192) pulses 1: 2^{17} (= 131072) pulses 2: 2^{18} (= 262144) pulses 3: 2^{20} (= 1048576) pulses 4: 2^{22} (= 4194304) pulses 5: 2^{24} (= 16777216) pulses 6: 2^{26} (= 67108864) pulses	3h																		
x___	For manufacturer setting	0h																		
PL02	**LIM	Linear encoder resolution - Numerator Set a linear encoder resolution per μm in [Pr. PL02] and [Pr. PL03]. Set the numerator in [Pr. PL02]. This is enabled only for linear servo motors.	1000 [μm]	1 to 65535	Each															
PL03	**LID	Linear encoder resolution - Denominator Set a linear encoder resolution per μm in [Pr. PL02] and [Pr. PL03]. Set the denominator in [Pr. PL03]. This is enabled only for linear servo motors.	1000 [μm]	1 to 65535	Each															

5. PARAMETERS

No.	Symbol	Name and function	Initial value [unit]	Setting range	Each/ Common																																									
PL04	*LIT2	<p>Linear servo motor/DD motor function selection 2</p> <p>This is used to select a detection function and detection controller reset condition of [AL. 42 Servo control error].</p> <table border="1"> <thead> <tr> <th>Setting digit</th> <th>Explanation</th> <th>Initial value</th> </tr> </thead> <tbody> <tr> <td>___x</td> <td> <p>[AL. 42 Servo control error] detection function selection</p> <p>Refer to the following table.</p> <table border="1"> <thead> <tr> <th>Setting value</th> <th>Torque/thrust deviation error (Note)</th> <th>Speed deviation error (Note)</th> <th>Position deviation error (Note)</th> </tr> </thead> <tbody> <tr> <td>0</td> <td rowspan="3">Disabled</td> <td>Disabled</td> <td>Disabled</td> </tr> <tr> <td>1</td> <td rowspan="2">Enabled</td> <td>Enabled</td> </tr> <tr> <td>2</td> <td>Disabled</td> </tr> <tr> <td>3</td> <td rowspan="4">Enabled</td> <td>Enabled</td> <td>Enabled</td> </tr> <tr> <td>4</td> <td rowspan="2">Disabled</td> <td>Disabled</td> </tr> <tr> <td>5</td> <td>Enabled</td> </tr> <tr> <td>6</td> <td rowspan="2">Enabled</td> <td>Disabled</td> </tr> <tr> <td>7</td> <td>Enabled</td> </tr> </tbody> </table> <p>Note. Refer to chapter 14 and 15 for details of each deviation error.</p> </td> <td>3h</td> </tr> <tr> <td>__x_</td> <td>For manufacturer setting</td> <td>0h</td> </tr> <tr> <td>_x__</td> <td></td> <td>0h</td> </tr> <tr> <td>x___</td> <td> <p>[AL. 42 Servo control error] detection function controller reset condition selection</p> <p>0: Reset disabled (reset by powering off/on enabled)</p> <p>1: Reset enabled</p> </td> <td>0h</td> </tr> </tbody> </table>	Setting digit	Explanation	Initial value	___x	<p>[AL. 42 Servo control error] detection function selection</p> <p>Refer to the following table.</p> <table border="1"> <thead> <tr> <th>Setting value</th> <th>Torque/thrust deviation error (Note)</th> <th>Speed deviation error (Note)</th> <th>Position deviation error (Note)</th> </tr> </thead> <tbody> <tr> <td>0</td> <td rowspan="3">Disabled</td> <td>Disabled</td> <td>Disabled</td> </tr> <tr> <td>1</td> <td rowspan="2">Enabled</td> <td>Enabled</td> </tr> <tr> <td>2</td> <td>Disabled</td> </tr> <tr> <td>3</td> <td rowspan="4">Enabled</td> <td>Enabled</td> <td>Enabled</td> </tr> <tr> <td>4</td> <td rowspan="2">Disabled</td> <td>Disabled</td> </tr> <tr> <td>5</td> <td>Enabled</td> </tr> <tr> <td>6</td> <td rowspan="2">Enabled</td> <td>Disabled</td> </tr> <tr> <td>7</td> <td>Enabled</td> </tr> </tbody> </table> <p>Note. Refer to chapter 14 and 15 for details of each deviation error.</p>	Setting value	Torque/thrust deviation error (Note)	Speed deviation error (Note)	Position deviation error (Note)	0	Disabled	Disabled	Disabled	1	Enabled	Enabled	2	Disabled	3	Enabled	Enabled	Enabled	4	Disabled	Disabled	5	Enabled	6	Enabled	Disabled	7	Enabled	3h	__x_	For manufacturer setting	0h	_x__		0h	x___	<p>[AL. 42 Servo control error] detection function controller reset condition selection</p> <p>0: Reset disabled (reset by powering off/on enabled)</p> <p>1: Reset enabled</p>	0h	Refer to Name and function column.	Each
Setting digit	Explanation	Initial value																																												
___x	<p>[AL. 42 Servo control error] detection function selection</p> <p>Refer to the following table.</p> <table border="1"> <thead> <tr> <th>Setting value</th> <th>Torque/thrust deviation error (Note)</th> <th>Speed deviation error (Note)</th> <th>Position deviation error (Note)</th> </tr> </thead> <tbody> <tr> <td>0</td> <td rowspan="3">Disabled</td> <td>Disabled</td> <td>Disabled</td> </tr> <tr> <td>1</td> <td rowspan="2">Enabled</td> <td>Enabled</td> </tr> <tr> <td>2</td> <td>Disabled</td> </tr> <tr> <td>3</td> <td rowspan="4">Enabled</td> <td>Enabled</td> <td>Enabled</td> </tr> <tr> <td>4</td> <td rowspan="2">Disabled</td> <td>Disabled</td> </tr> <tr> <td>5</td> <td>Enabled</td> </tr> <tr> <td>6</td> <td rowspan="2">Enabled</td> <td>Disabled</td> </tr> <tr> <td>7</td> <td>Enabled</td> </tr> </tbody> </table> <p>Note. Refer to chapter 14 and 15 for details of each deviation error.</p>	Setting value	Torque/thrust deviation error (Note)	Speed deviation error (Note)	Position deviation error (Note)	0	Disabled	Disabled	Disabled	1	Enabled	Enabled		2	Disabled	3	Enabled	Enabled	Enabled	4	Disabled		Disabled	5	Enabled	6	Enabled	Disabled	7	Enabled	3h															
Setting value	Torque/thrust deviation error (Note)	Speed deviation error (Note)	Position deviation error (Note)																																											
0	Disabled	Disabled	Disabled																																											
1		Enabled	Enabled																																											
2			Disabled																																											
3	Enabled	Enabled	Enabled																																											
4		Disabled	Disabled																																											
5			Enabled																																											
6		Enabled	Disabled																																											
7	Enabled																																													
__x_	For manufacturer setting	0h																																												
_x__		0h																																												
x___	<p>[AL. 42 Servo control error] detection function controller reset condition selection</p> <p>0: Reset disabled (reset by powering off/on enabled)</p> <p>1: Reset enabled</p>	0h																																												
PL05	LB1	<p>Position deviation error detection level</p> <p>This is used to set the position deviation error detection level of the servo control error detection.</p> <p>When the deviation between a model feedback position and actual feedback position is larger than the setting value, [AL. 42 Servo control error] will occur.</p> <p>However, when "0" is set, the level vary depending on the operation mode in [Pr. PA01].</p> <p>Linear servo motor: 50 mm</p> <p>Direct drive motor: 0.09 rev</p>	0 [mm]/ [0.01rev]	0 to 1000	Each																																									
PL06	LB2	<p>Speed deviation error detection level</p> <p>This is used to set the speed deviation error detection level of the servo control error detection.</p> <p>When the deviation between a model feedback speed and actual feedback speed is larger than the setting value, [AL. 42 Servo control error] will occur.</p> <p>However, when "0" is set, the level vary depending on the operation mode in [Pr. PA01].</p> <p>Linear servo motor: 1000 mm/s</p> <p>Direct drive motor: 100 r/min</p>	0 [mm/s]/ [r/min]	0 to 5000	Each																																									
PL07	LB3	<p>Torque/thrust deviation error detection level</p> <p>This is used to set the torque/thrust deviation error detection level of the servo control error detection.</p> <p>When the deviation between a current command and current feedback is larger than the setting value, [AL. 42.3 Servo control error by torque/thrust deviation] will occur.</p>	100 [%]	0 to 1000	Each																																									

5. PARAMETERS

No.	Symbol	Name and function	Initial value [unit]	Setting range	Each/ Common															
PL08	*LIT3	Linear servo motor/DD motor function selection 3	Refer to Name and function column.		Each															
		<table border="1"> <thead> <tr> <th>Setting digit</th> <th>Explanation</th> <th>Initial value</th> </tr> </thead> <tbody> <tr> <td>___x</td> <td>Magnetic pole detection method selection 0: Position detection method 4: Minute position detection method</td> <td>0h</td> </tr> <tr> <td>__x_</td> <td>For manufacturer setting</td> <td>1h</td> </tr> <tr> <td>_x__</td> <td>Magnetic pole detection - Stroke limit enabled/disabled selection 0: Enabled 1: Disabled</td> <td>0h</td> </tr> <tr> <td>x___</td> <td>For manufacturer setting</td> <td>0h</td> </tr> </tbody> </table>				Setting digit	Explanation	Initial value	___x	Magnetic pole detection method selection 0: Position detection method 4: Minute position detection method	0h	__x_	For manufacturer setting	1h	_x__	Magnetic pole detection - Stroke limit enabled/disabled selection 0: Enabled 1: Disabled	0h	x___	For manufacturer setting	0h
		Setting digit				Explanation	Initial value													
		___x				Magnetic pole detection method selection 0: Position detection method 4: Minute position detection method	0h													
		__x_				For manufacturer setting	1h													
_x__	Magnetic pole detection - Stroke limit enabled/disabled selection 0: Enabled 1: Disabled	0h																		
x___	For manufacturer setting	0h																		
PL09	LPWM	<p>Magnetic pole detection voltage level</p> <p>This is used to set a direct current exciting voltage level during the magnetic pole detection.</p> <p>If [AL. 32 Overcurrent], [AL. 50 Overload 1], or [AL. 51 Overload 2] occurs during the magnetic pole detection, decrease the setting value.</p> <p>If [AL. 27 Initial magnetic pole detection error] occurs during the magnetic pole detection, increase the setting value.</p>	30 [%]	0 to 100	Each															

5. PARAMETERS

No.	Symbol	Name and function	Initial value [unit]	Setting range	Each/ Common																																				
PL17	LTSTS	Magnetic pole detection - Minute position detection method - Function selection To enable the parameter, select "Minute position detection method (_ _ _ 4)" in [Pr. PL08].	Refer to Name and function column.		Each																																				
		<table border="1"> <thead> <tr> <th>Setting digit</th> <th>Explanation</th> <th>Initial value</th> </tr> </thead> <tbody> <tr> <td>_ _ _ x</td> <td>Response selection Set a response of the minute position detection method. When reducing a travel distance at the magnetic pole detection, increase the setting value. Refer to table 5.8 for settings.</td> <td>0h</td> </tr> <tr> <td>_ _ x _</td> <td>Load to motor mass ratio/load to motor inertia ratio selection Select a load to mass of the linear servo motor primary-side ratio or load to mass of the direct drive motor inertia ratio used at the minute position detection method. Set a closest value to the actual load. Refer to table 5.9 for settings.</td> <td>0h</td> </tr> <tr> <td>_ x _ _</td> <td rowspan="2">For manufacturer setting</td> <td>0h</td> </tr> <tr> <td>x _ _ _</td> <td>0h</td> </tr> </tbody> </table>				Setting digit	Explanation	Initial value	_ _ _ x	Response selection Set a response of the minute position detection method. When reducing a travel distance at the magnetic pole detection, increase the setting value. Refer to table 5.8 for settings.	0h	_ _ x _	Load to motor mass ratio/load to motor inertia ratio selection Select a load to mass of the linear servo motor primary-side ratio or load to mass of the direct drive motor inertia ratio used at the minute position detection method. Set a closest value to the actual load. Refer to table 5.9 for settings.	0h	_ x _ _	For manufacturer setting	0h	x _ _ _	0h																						
		Setting digit				Explanation	Initial value																																		
		_ _ _ x				Response selection Set a response of the minute position detection method. When reducing a travel distance at the magnetic pole detection, increase the setting value. Refer to table 5.8 for settings.	0h																																		
		_ _ x _				Load to motor mass ratio/load to motor inertia ratio selection Select a load to mass of the linear servo motor primary-side ratio or load to mass of the direct drive motor inertia ratio used at the minute position detection method. Set a closest value to the actual load. Refer to table 5.9 for settings.	0h																																		
		_ x _ _				For manufacturer setting	0h																																		
		x _ _ _					0h																																		
		<p>Table 5.8 Response of minute position detection method at magnetic pole detection</p> <table border="1"> <thead> <tr> <th>Setting value</th> <th>Response</th> <th>Setting value</th> <th>Response</th> </tr> </thead> <tbody> <tr> <td>0</td> <td rowspan="7" style="text-align: center;"> Low response ↑ ↓ Middle response </td> <td>8</td> <td rowspan="7" style="text-align: center;"> Middle response ↑ ↓ High response </td> </tr> <tr><td>1</td></tr> <tr><td>2</td></tr> <tr><td>3</td></tr> <tr><td>4</td></tr> <tr><td>5</td></tr> <tr><td>6</td></tr> <tr><td>7</td></tr> <tr> <td></td> <td></td> <td></td> <td></td> </tr> </tbody> </table>						Setting value	Response	Setting value	Response	0	Low response ↑ ↓ Middle response	8	Middle response ↑ ↓ High response	1	2	3	4	5	6	7																			
		Setting value				Response	Setting value	Response																																	
		0				Low response ↑ ↓ Middle response	8	Middle response ↑ ↓ High response																																	
1																																									
2																																									
3																																									
4																																									
5																																									
6																																									
7																																									
<p>Table 5.9 Load to motor mass ratio/load to motor inertia ratio</p> <table border="1"> <thead> <tr> <th>Setting value</th> <th>Load to motor mass ratio/load to motor inertia ratio</th> <th>Setting value</th> <th>Load to motor mass ratio/load to motor inertia ratio</th> </tr> </thead> <tbody> <tr><td>0</td><td>10 times or less</td><td>8</td><td>80 times</td></tr> <tr><td>1</td><td>10 times</td><td>9</td><td>90 times</td></tr> <tr><td>2</td><td>20 times</td><td>A</td><td>100 times</td></tr> <tr><td>3</td><td>30 times</td><td>B</td><td>110 times</td></tr> <tr><td>4</td><td>40 times</td><td>C</td><td>120 times</td></tr> <tr><td>5</td><td>50 times</td><td>D</td><td>130 times</td></tr> <tr><td>6</td><td>60 times</td><td>E</td><td>140 times</td></tr> <tr><td>7</td><td>70 times</td><td>F</td><td>150 times or more</td></tr> </tbody> </table>						Setting value	Load to motor mass ratio/load to motor inertia ratio	Setting value	Load to motor mass ratio/load to motor inertia ratio	0	10 times or less	8	80 times	1	10 times	9	90 times	2	20 times	A	100 times	3	30 times	B	110 times	4	40 times	C	120 times	5	50 times	D	130 times	6	60 times	E	140 times	7	70 times	F	150 times or more
Setting value	Load to motor mass ratio/load to motor inertia ratio	Setting value	Load to motor mass ratio/load to motor inertia ratio																																						
0	10 times or less	8	80 times																																						
1	10 times	9	90 times																																						
2	20 times	A	100 times																																						
3	30 times	B	110 times																																						
4	40 times	C	120 times																																						
5	50 times	D	130 times																																						
6	60 times	E	140 times																																						
7	70 times	F	150 times or more																																						
PL18	IDLV	Magnetic pole detection - Minute position detection method - Identification signal amplitude Set an identification signal amplitude used in the minute position detection method. This parameter is enabled only when the magnetic pole detection is the minute position detection method. However, setting "0" will be 100% amplitude.	0 [%]	0 to 100	Each																																				

6. NORMAL GAIN ADJUSTMENT

6. NORMAL GAIN ADJUSTMENT

POINT
<ul style="list-style-type: none"> ● In the torque control mode, you do not need to make gain adjustment. ● Before making gain adjustment, check that your machine is not being operated at maximum torque of the servo motor. If operated over maximum torque, the machine may vibrate and may operate unexpectedly. In addition, make gain adjustment with a safety margin considering characteristic differences of each machine. It is recommended that generated torque during operation is under 90% of the maximum torque of the servo motor. ● When you use a linear servo motor, replace the following left words to the right words. Load to motor inertia ratio → Load to motor mass ratio Torque → Thrust (Servo motor) speed → (Linear servo motor) speed

6.1 Different adjustment methods

6.1.1 Adjustment on a single servo amplifier

The following table shows the gain adjustment modes that can be set on a single servo amplifier. For gain adjustment, first execute "Auto tuning mode 1". If you are not satisfied with the result of the adjustment, execute "Auto tuning mode 2" and "Manual mode" in this order.

(1) Gain adjustment mode explanation

Gain adjustment mode	[Pr. PA08] setting	Estimation of load to motor inertia ratio	Automatically set parameters	Manually set parameters
Auto tuning mode 1 (initial value)	___ 1	Always estimated	GD2 ([Pr. PB06]) PG1 ([Pr. PB07]) PG2 ([Pr. PB08]) VG2 ([Pr. PB09]) VIC ([Pr. PB10])	RSP ([Pr. PA09])
Auto tuning mode 2	___ 2	Fixed to [Pr. PB06] value	PG1 ([Pr. PB07]) PG2 ([Pr. PB08]) VG2 ([Pr. PB09]) VIC ([Pr. PB10])	GD2 ([Pr. PB06]) RSP ([Pr. PA09])
Manual mode	___ 3		/	GD2 ([Pr. PB06]) PG1 ([Pr. PB07]) PG2 ([Pr. PB08]) VG2 ([Pr. PB09]) VIC ([Pr. PB10])
2 gain adjustment mode 1 (interpolation mode)	___ 0	Always estimated	GD2 ([Pr. PB06]) PG2 ([Pr. PB08]) VG2 ([Pr. PB09]) VIC ([Pr. PB10])	PG1 ([Pr. PB07]) RSP ([Pr. PA09])
2 gain adjustment mode 2	___ 4	Fixed to [Pr. PB06] value	PG2 ([Pr. PB08]) VG2 ([Pr. PB09]) VIC ([Pr. PB10])	GD2 ([Pr. PB06]) PG1 ([Pr. PB07]) RSP ([Pr. PA09])

6. NORMAL GAIN ADJUSTMENT

(2) Adjustment sequence and mode usage

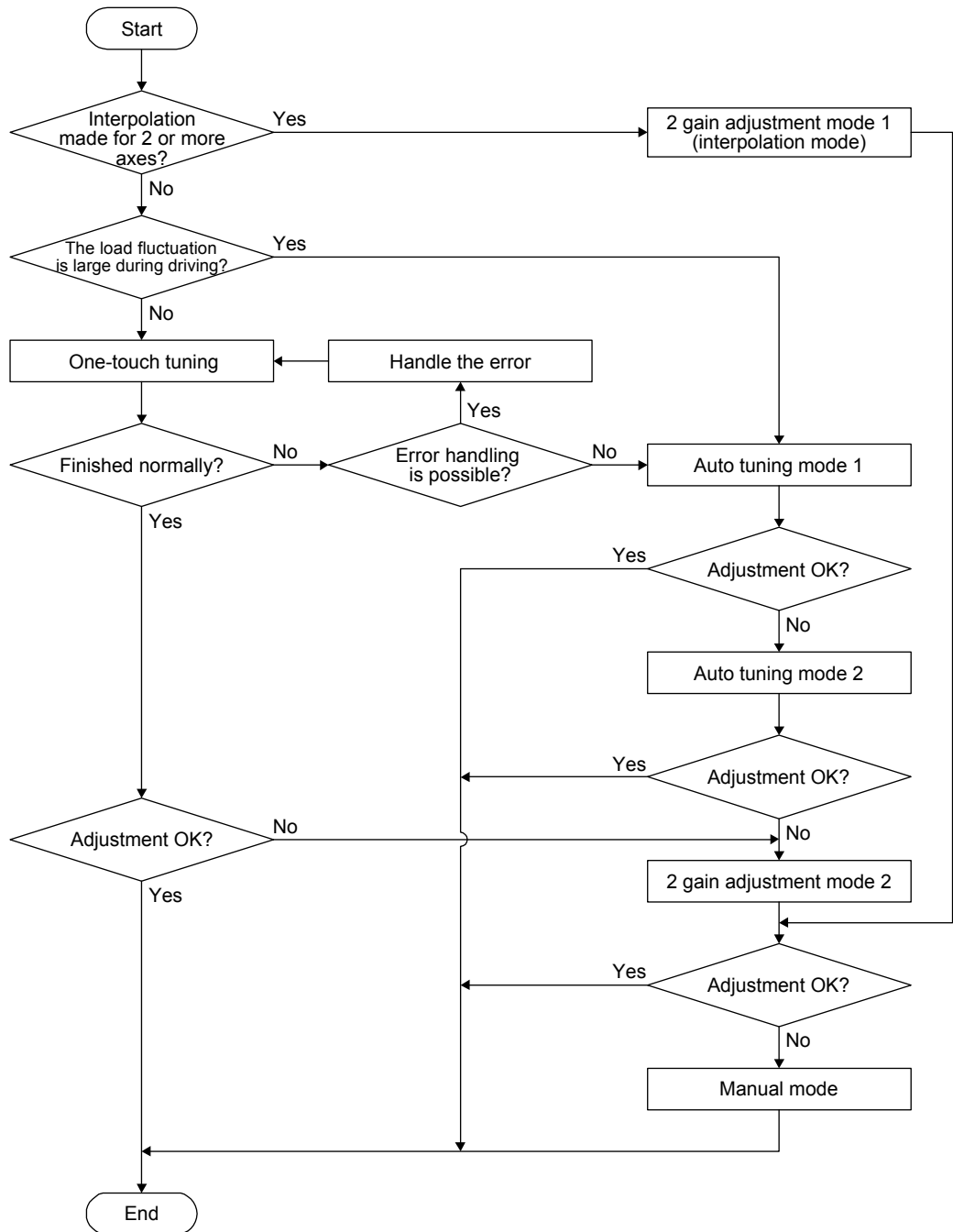

6.1.2 Adjustment using MR Configurator2

This section explains the functions and adjustment using the servo amplifier with MR Configurator2.

Function	Description	Adjustment
Machine analyzer	With the machine and servo motor coupled, the characteristic of the mechanical system can be measured by giving a random vibration command from a personal computer to the servo and measuring the machine response.	You can grasp the machine resonance frequency and determine the notch frequency of the machine resonance suppression filter.

6. NORMAL GAIN ADJUSTMENT

6.2 One-touch tuning

Connect MR Configurator2 and open the one-touch tuning window, and you can use the function. The following parameters are set automatically with one-touch tuning.

Table 6.1 List of parameters automatically set with one-touch tuning

Parameter	Symbol	Name	Parameter	Symbol	Name
PA08	ATU	Auto tuning mode	PB16	NHQ2	Notch shape selection 2
PA09	RSP	Auto tuning response	PB18	LPF	Low-pass filter setting
PB01	FILT	Adaptive tuning mode (adaptive filter II)	PB19	VRF11	Vibration suppression control 1 - Vibration frequency
PB02	VRFT	Vibration suppression control tuning mode (advanced vibration suppression control II)	PB20	VRF12	Vibration suppression control 1 - Resonance frequency
PB06	GD2	Load to motor inertia ratio/load to motor mass ratio	PB21	VRF13	Vibration suppression control 1 - Vibration frequency damping
PB07	PG1	Model loop gain	PB22	VRF14	Vibration suppression control 1 - Resonance frequency damping
PB08	PG2	Position loop gain	PB23	VFBF	Low-pass filter selection
PB09	VG2	Speed loop gain	PB47	NHQ3	Notch shape selection 3
PB10	VIC	Speed integral compensation	PB48	NH4	Machine resonance suppression filter 4
PB12	OVA	Overshoot amount compensation	PB49	NHQ4	Notch shape selection 4
PB13	NH1	Machine resonance suppression filter 1	PB51	NHQ5	Notch shape selection 5
PB14	NHQ1	Notch shape selection 1	PE41	EOP3	Function selection E-3
PB15	NH2	Machine resonance suppression filter 2			

6.2.1 One-touch tuning flowchart

Make one-touch tuning as follows.

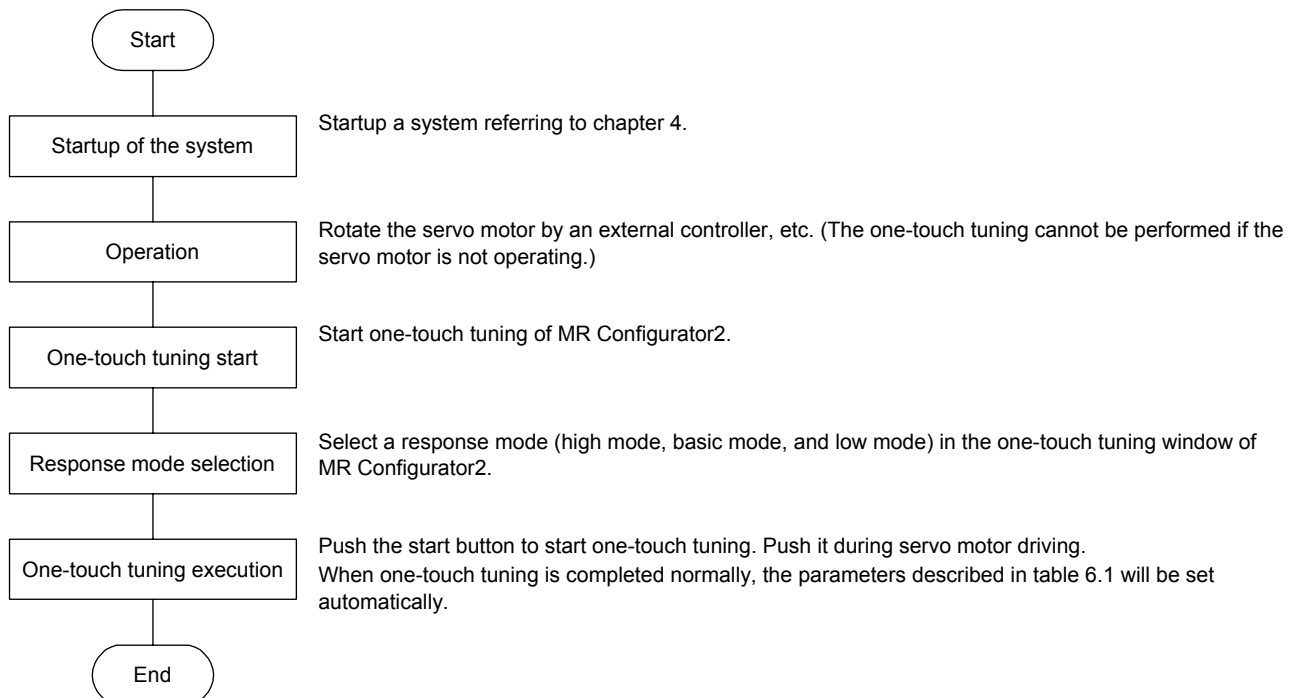

6. NORMAL GAIN ADJUSTMENT

6.2.2 Display transition and operation procedure of one-touch tuning

(1) Response mode selection

Select a response mode from 3 modes in the one-touch tuning window of MR Configurator2.

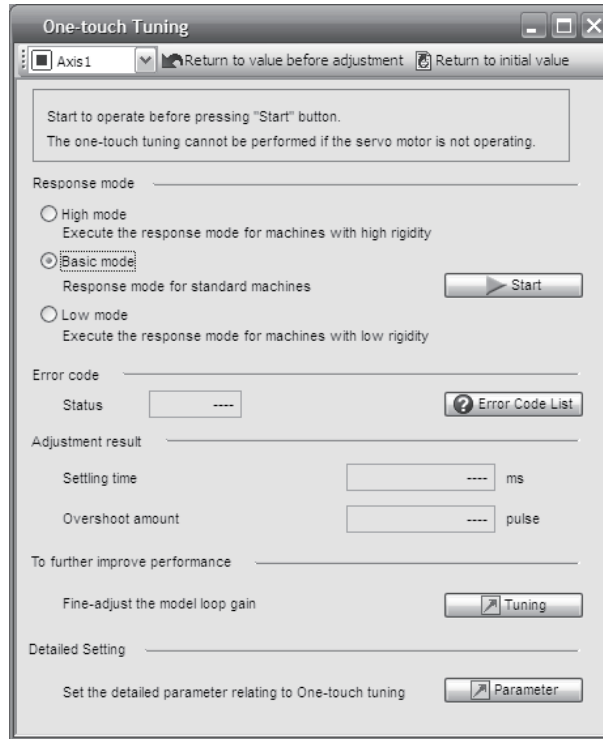

Response mode	Explanation
High mode	This mode is for high rigid system.
Basic mode	This mode is for standard system.
Low mode	This mode is for low rigid system.

Refer to the following table for selecting a response mode.

6. NORMAL GAIN ADJUSTMENT

Response mode			Response	Machine characteristic
Low mode	Basic mode	High mode		Guideline of corresponding machine
↑ ↓	↑ ↓	↑ ↓	Low response ↑ ↓ High response	<p>Arm robot</p> <p>General machine tool conveyor</p> <p>Precision working machine</p> <p>Inserter Mounter Bonder</p>

6. NORMAL GAIN ADJUSTMENT

(2) One-touch tuning execution

POINT
● For equipment in which overshoot during one-touch tuning is permissible level within in-position range, changing the value of [Pr. PA25 One-touch tuning - Overshoot permissible level] will shorten the settling time and improve the response.

After the response mode is selected in (1), pushing the start button during driving will start one-touch tuning. If the start button is pushed while the motor stops, "C 0 0 2" or "C 0 0 4" will be displayed at status in error code. (Refer to (4) in this section for error codes.)

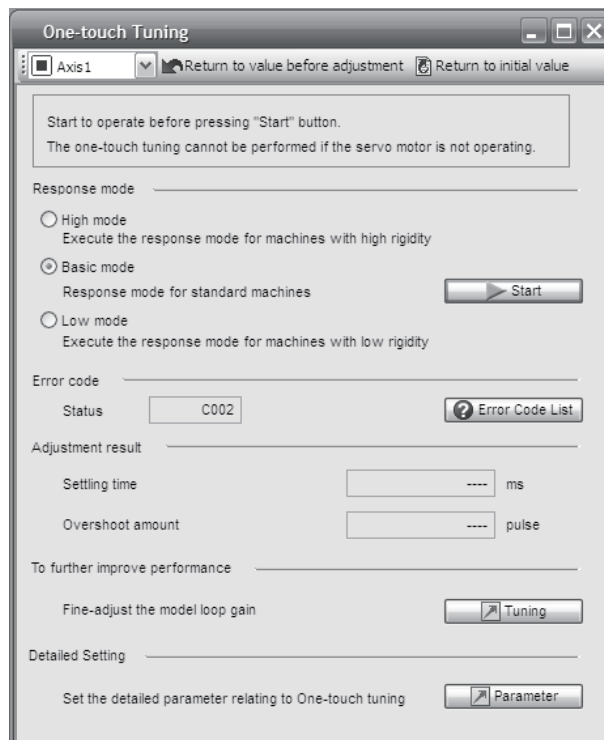

During processing of one-touch tuning, the status will be displayed in the progress window as follows. One-touch tuning will be finished at 100%.



Completing the one-touch tuning starts writing tuning parameters to the servo amplifier. "0 0 0 0" is displayed at status in error code. In addition, settling time and overshoot amount will be displayed in "Adjustment result" after adjustment.

6. NORMAL GAIN ADJUSTMENT

(3) One-touch tuning execution

During one-touch tuning, pushing the stop button stops one-touch tuning.

If the one-touch tuning is stopped, "C 0 0 0" will be displayed at status in error code.

(4) If an error occur

If a tuning error occurs during tuning, one-touch tuning will be forcibly terminated. With that, the following error code will be displayed in status. Check the cause of tuning error.

Error code	Name	Description	Action
C000	Tuning canceled	The stop button was pushed during one-touch tuning.	
C001	Overshoot exceeded	The overshoot amount is larger than the value set in [Pr. PA10 In-position range].	Increase the in-position range.
C002	Servo-off during tuning	The one-touch tuning was attempted during servo-off.	Perform the one-touch tuning after servo-on.
C003	Control mode error	The one-touch tuning was attempted while the torque control mode was selected in the control modes.	Select the position control mode or speed control mode for the control mode from the controller, and then make one-touch tuning.
C004	Time-out	1. 1 cycle time during the operation has been over 30 s.	Set the 1 cycle time during the operation to 30 s or less.
		2. The command speed is low.	Set the servo motor speed to 100 r/min or higher.
		3. The operation interval of the continuous operation is short.	Maintain the operation interval during motor driving about 200 ms.
C005	Load to motor inertia ratio misestimated	1. The estimation of the load to motor inertia ratio at one-touch tuning was a failure.	Drive the motor with meeting conditions as follows. <ul style="list-style-type: none"> • The time until the acceleration/deceleration time constant reach 2000 r/min (mm/s) is 5 s or less. • Speed is 150 r/min (mm/s) or higher. • The load to servo motor (mass of linear servo motor's primary side or direct drive motor) inertia ratio is 100 times or less. • The acceleration/deceleration torque is 10% or more of the rated torque.
		2. The load to motor inertia ratio was not estimated due to such as an oscillation.	Set to the auto tuning mode that does not estimate the load to motor inertia ratio as follows, and then execute the one-touch tuning. <ul style="list-style-type: none"> • Select "Auto tuning mode 2 (_ _ _ 2)", "Manual mode (_ _ _ 3)", or "2 gain adjustment mode 2 (_ _ _ 4)" of "Gain adjustment mode selection" in [Pr. PA08]. • Set [Pr. PB06 Load to motor inertia ratio/load to motor mass ratio] properly with manual setting.
C00E	Communication cycle setting error	The communication cycle of the controller was set to 0.222 ms while MR-J4W3- _ B is used.	Set the communication cycle of the controller to 0.444 ms or longer.
C00F	One-touch tuning disabled	"One-touch tuning function selection" in [Pr. PA21] is "Disabled (_ _ _ 0)".	Select "Enabled (_ _ _ 1)".

(5) If an alarm occur

If an alarm occurs during tuning, one-touch tuning will be forcibly terminated.

Remove the cause of the alarm and execute one-touch tuning again.

6. NORMAL GAIN ADJUSTMENT

(6) If a warning occur

If a warning which continue the motor driving occurs during the tuning, one-touch tuning will be continued.

If a warning which does not continue the motor driving occurs during the tuning, one-touch tuning will be stopped.

(7) Clearing one-touch tuning

You can clear the parameter values set with one-touch tuning.

Refer to table 6.1 for the parameters which you can clear.

Pushing "Return to value before adjustment" in the one-touch tuning window of MR Configurator2 enables to rewrite the parameter to the value before pushing the start button.

In addition, pushing "Return to initial value" in the one-touch tuning window enables to rewrite the parameter to the initial value.

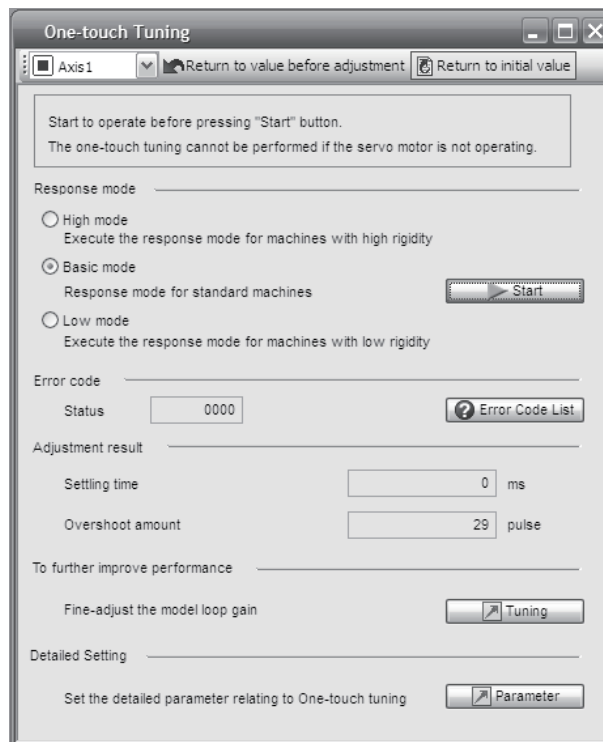

Clearing one-touch tuning is completed, the following window will be displayed. (returning to initial value)

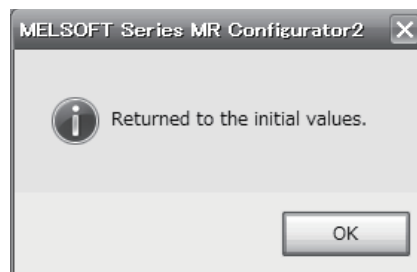

6. NORMAL GAIN ADJUSTMENT

6.2.3 Caution for one-touch tuning

- (1) The tuning is not available in the torque control mode.
- (2) The one-touch tuning cannot be executed while an alarm or warning which does not continue the motor driving is occurring.
- (3) The tuning is not available during the following test operation mode.
 - (a) Output signal (DO) forced output
 - (b) Motor-less operation

6. NORMAL GAIN ADJUSTMENT

6.3 Auto tuning

6.3.1 Auto tuning mode

The servo amplifier has a real-time auto tuning function which estimates the machine characteristic (load to motor inertia ratio) in real time and automatically sets the optimum gains according to that value. This function permits ease of gain adjustment of the servo amplifier.

(1) Auto tuning mode 1

The servo amplifier is factory-set to the auto tuning mode 1.

In this mode, the load to motor inertia ratio of a machine is always estimated to set the optimum gains automatically.

The following parameters are automatically adjusted in the auto tuning mode 1.

Parameter	Symbol	Name
PB06	GD2	Load to motor inertia ratio/load to motor mass ratio
PB07	PG1	Model loop gain
PB08	PG2	Position loop gain
PB09	VG2	Speed loop gain
PB10	VIC	Speed integral compensation

POINT
<ul style="list-style-type: none">● The auto tuning mode 1 may not be performed properly if all of the following conditions are not satisfied.<ul style="list-style-type: none">▪ The time until the acceleration/deceleration time constant reach 2000 r/min (mm/s) is 5 s or less.▪ Speed is 150 r/min (mm/s) or higher.▪ The load to servo motor (mass of linear servo motor's primary side or direct drive motor) inertia ratio is 100 times or less.▪ The acceleration/deceleration torque is 10% or more of the rated torque.● Under operating conditions which will impose sudden disturbance torque during acceleration/deceleration or on a machine which is extremely loose, auto tuning may not function properly, either. In such cases, use the auto tuning mode 2 or manual mode to make gain adjustment.

(2) Auto tuning mode 2

Use the auto tuning mode 2 when proper gain adjustment cannot be made by auto tuning mode 1. Since the load to motor inertia ratio is not estimated in this mode, set the value of a correct load to motor inertia ratio in [Pr. PB06].

The following parameters are automatically adjusted in the auto tuning mode 2.

Parameter	Symbol	Name
PB07	PG1	Model loop gain
PB08	PG2	Position loop gain
PB09	VG2	Speed loop gain
PB10	VIC	Speed integral compensation

6. NORMAL GAIN ADJUSTMENT

6.3.2 Auto tuning mode basis

The block diagram of real-time auto tuning is shown below.

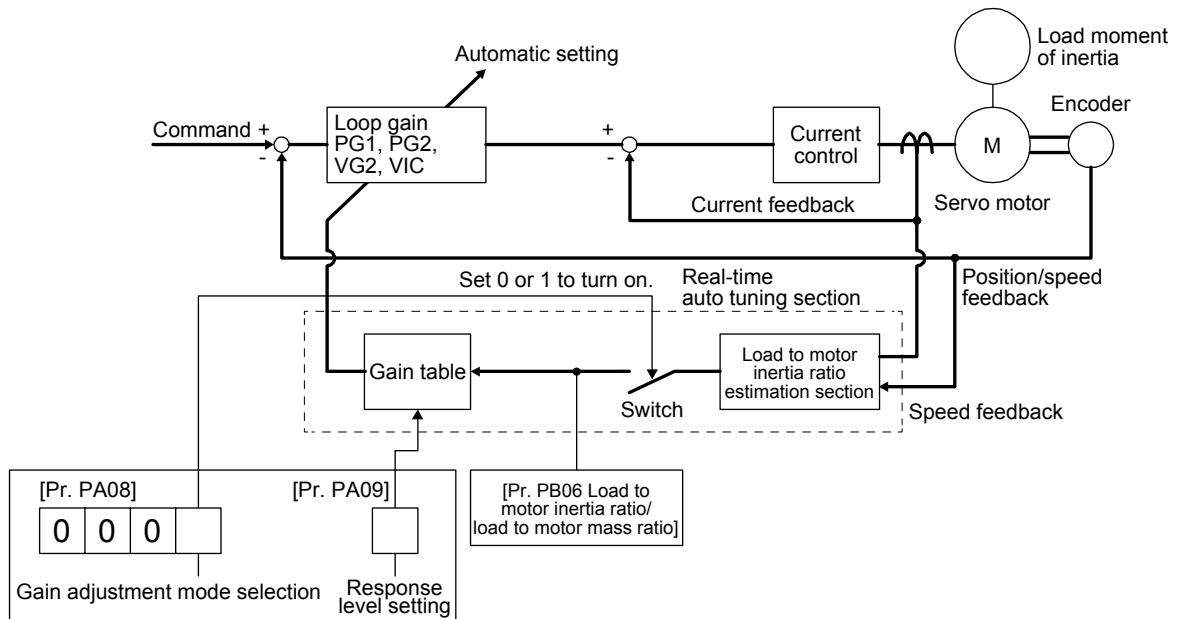

When a servo motor is accelerated/decelerated, the load to motor inertia ratio estimation section always estimates the load to motor inertia ratio from the current and speed of the servo motor. The results of estimation are written to [Pr. PB06 Load to motor inertia ratio/load to motor mass ratio]. These results can be confirmed on the status display screen of the MR Configurator2.

If you have already known the value of the load to motor inertia ratio or failed to estimate, set "Gain adjustment mode selection" to "Auto tuning mode 2 (_ _ 2)" in [Pr. PA08] to stop the estimation (turning off the switch in above diagram), and set the load to motor inertia ratio or load to motor mass ratio ([Pr. PB06]) manually.

From the preset load to motor inertia ratio ([Pr. PB06]) value and response ([Pr. PA09]), the optimum loop gains are automatically set on the basis of the internal gain table.

The auto tuning results are saved in the EEPROM of the servo amplifier every 60 minutes since power-on. At power-on, auto tuning is performed with the value of each loop gain saved in the EEPROM being used as an initial value.

POINT
<ul style="list-style-type: none"> ● If sudden disturbance torque is imposed during operation, the load to motor inertia ratio may be misestimated temporarily. In such a case, set "Gain adjustment mode selection" to "Auto tuning mode 2 (_ _ 2)" in [Pr. PA08] and then set the correct load to motor inertia ratio in [Pr. PB06]. ● When any of the auto tuning mode 1 and auto tuning mode settings is changed to the manual mode 2 setting, the current loop gains and load to motor inertia ratio estimation value are saved in the EEPROM.

6. NORMAL GAIN ADJUSTMENT

6.3.3 Adjustment procedure by auto tuning

Since auto tuning is enabled before shipment from the factory, simply running the servo motor automatically sets the optimum gains that match the machine. Merely changing the response level setting value as required completes the adjustment. The adjustment procedure is as follows.

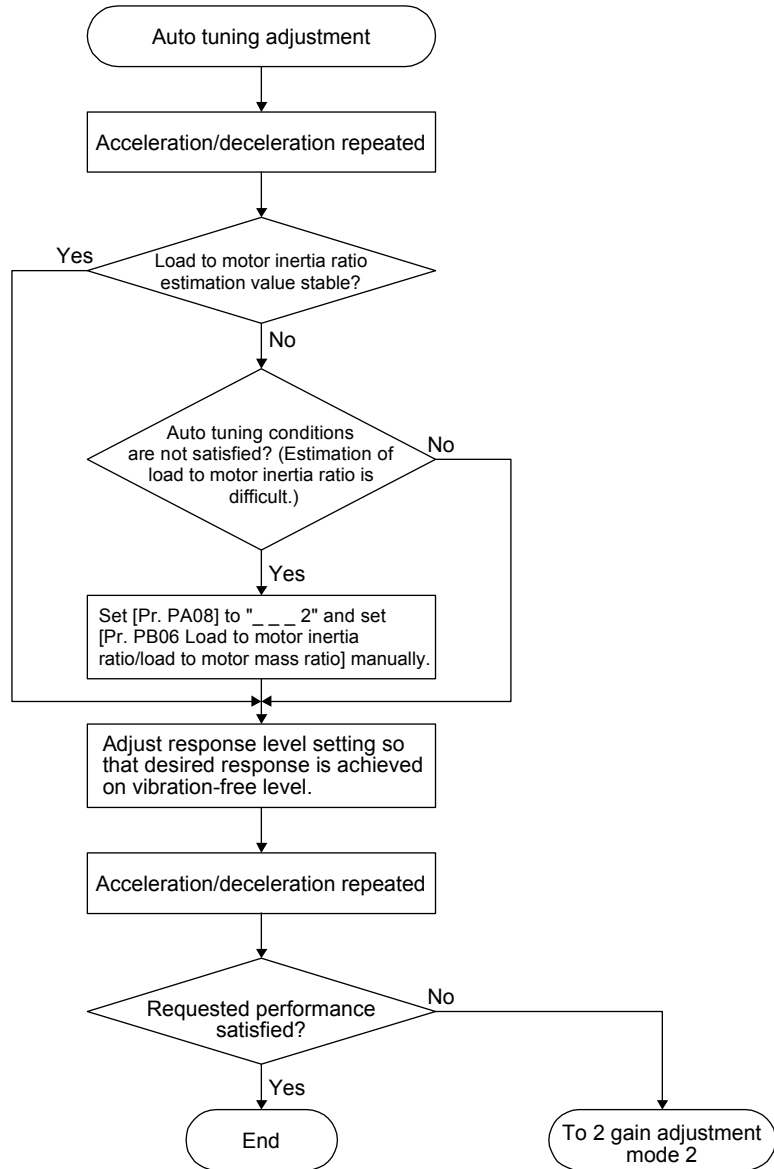

6. NORMAL GAIN ADJUSTMENT

6.3.4 Response level setting in auto tuning mode

Set the response of the whole servo system by [Pr. PA09]. As the response level setting is increased, the track ability and settling time for a command decreases, but a too high response level will generate vibration. Hence, make setting until desired response is obtained within the vibration-free range.

If the response level setting cannot be increased up to the desired response because of machine resonance beyond 100 Hz, filter tuning mode selection in [Pr. PB01] or machine resonance suppression filter in [Pr. PB13] to [Pr. PB16], [Pr. PB46] to [Pr. PB51] may be used to suppress machine resonance. Suppressing machine resonance may allow the response level setting to increase. Refer to section 7.2 and 7.3 for settings of the adaptive tuning mode and machine resonance suppression filter.

[Pr. PA09]

Setting value	Machine characteristic		Reference (setting value of MR-J3 and MR-J3W)
	Response	Guideline for machine resonance frequency [Hz]	
1	Low response ↑	2.7	
2		3.6	
3		4.9	
4		6.6	
5		10.0	1
6		11.3	2
7		12.7	3
8		14.3	4
9		16.1	5
10		18.1	6
11		20.4	7
12		23.0	8
13		25.9	9
14		29.2	10
15		32.9	11
16		37.0	12
17		41.7	13
18		47.0	14
19	Middle response	52.9	15
20		59.6	16

Setting value	Machine characteristic		Reference (setting value of MR-J3 and MR-J3W)
	Response	Guideline for machine resonance frequency [Hz]	
21	Middle response ↑	67.1	17
22		75.6	18
23		85.2	19
24		95.9	20
25		108.0	21
26		121.7	22
27		137.1	23
28		154.4	24
29		173.9	25
30		195.9	26
31		220.6	27
32		248.5	28
33		279.9	29
34		315.3	30
35		355.1	31
36		400.0	32
37		446.6	
38		501.2	
39	High response	571.5	
40		642.7	

6. NORMAL GAIN ADJUSTMENT

6.4 Manual mode

If you are not satisfied with the adjustment of auto tuning, you can make simple manual adjustment with three parameters.

POINT
<ul style="list-style-type: none"> ● If machine resonance occurs, filter tuning mode selection in [Pr. PB01] or machine resonance suppression filter in [Pr. PB13] to [Pr. PB16] and [Pr. PB46] to [Pr. PB51] may be used to suppress machine resonance. (Refer to section 7.2 to 7.3.)

(1) For speed control

(a) Parameter

The following parameters are used for gain adjustment.

Parameter	Symbol	Name
PB06	GD2	Load to motor inertia ratio/load to motor mass ratio
PB07	PG1	Model loop gain
PB09	VG2	Speed loop gain
PB10	VIC	Speed integral compensation

(b) Adjustment procedure

Step	Operation	Description
1	Brief-adjust with auto tuning. Refer to section 6.2.3.	
2	Change the setting of auto tuning to the manual mode ([Pr. PA08]: ___ 3).	
3	Set the estimated value to the load to motor inertia ratio/load to motor mass ratio. (If the estimate value with auto tuning is correct, setting change is not required.)	
4	Set a slightly smaller value to the model loop gain Set a slightly larger value to the speed integral compensation.	
5	Increase the speed loop gain within the vibration- and unusual noise-free range, and return slightly if vibration takes place.	Increase the speed loop gain.
6	Decrease the speed integral compensation within the vibration-free range, and return slightly if vibration takes place.	Decrease the time constant of the speed integral compensation.
7	Increase the model loop gain, and return slightly if overshoot takes place.	Increase the model loop gain.
8	If the gains cannot be increased due to mechanical system resonance or the like and the desired response cannot be achieved, response may be increased by suppressing resonance with the adaptive tuning mode or machine resonance suppression filter and then executing steps 3 to 7.	Suppression of machine resonance Refer to section 7.2 and 7.3.
9	While checking the motor status, fine-adjust each gain.	Fine adjustment

6. NORMAL GAIN ADJUSTMENT

(c) Parameter adjustment

1) [Pr. PB09 Speed loop gain]

This parameter determines the response level of the speed control loop. Increasing this value enhances response but a too high value will make the mechanical system liable to vibrate. The actual response frequency of the speed loop is as indicated in the following expression.

$$\text{Speed loop response frequency [Hz]} = \frac{\text{Speed loop gain}}{(1 + \text{Load to motor inertia ratio}) \times 2\pi}$$

2) [Pr. PB10 Speed integral compensation]

To eliminate stationary deviation against a command, the speed control loop is under proportional integral control. For the speed integral compensation, set the time constant of this integral control. Increasing the setting lowers the response level. However, if the load to motor inertia ratio is large or the mechanical system has any vibratory element, the mechanical system is liable to vibrate unless the setting is increased to some degree. The guideline is as indicated in the following expression.

$$\begin{aligned} &\text{Speed integral compensation setting [ms]} \\ &\quad 2000 \text{ to } 3000 \\ &\geq \frac{\text{Speed loop gain}}{(1 + \text{Load to motor inertia ratio})} \end{aligned}$$

3) [Pr. PB07 Model loop gain]

This parameter determines the response level to a speed command. Increasing the value improves track ability to a speed command, but a too high value will make overshoot liable to occur at settling.

$$\text{Model loop gain guideline} \leq \frac{\text{Speed loop gain}}{(1 + \text{Load to motor inertia ratio})} \times \left(\frac{1}{4} \text{ to } \frac{1}{8} \right)$$

(2) For position control

(a) Parameter

The following parameters are used for gain adjustment.

Parameter	Symbol	Name
PB06	GD2	Load to motor inertia ratio/load to motor mass ratio
PB07	PG1	Model loop gain
PB08	PG2	Position loop gain
PB09	VG2	Speed loop gain
PB10	VIC	Speed integral compensation

6. NORMAL GAIN ADJUSTMENT

(b) Adjustment procedure

Step	Operation	Description
1	Brief-adjust with auto tuning. Refer to section 6.2.3.	
2	Change the setting of auto tuning to the manual mode ([Pr. PA08]: __ _ 3).	
3	Set the estimated value to the load to motor inertia ratio/load to motor mass ratio. (If the estimate value with auto tuning is correct, setting change is not required.)	
4	Set a slightly smaller value to the model loop gain and the position loop gain. Set a slightly larger value to the speed integral compensation.	
5	Increase the speed loop gain within the vibration- and unusual noise-free range, and return slightly if vibration takes place.	Increase the speed loop gain.
6	Decrease the speed integral compensation within the vibration-free range, and return slightly if vibration takes place.	Decrease the time constant of the speed integral compensation.
7	Increase the position loop gain, and return slightly if vibration takes place.	Increase the position loop gain.
8	Increase the model loop gain, and return slightly if overshoot takes place.	Increase the model loop gain.
9	If the gains cannot be increased due to mechanical system resonance or the like and the desired response cannot be achieved, response may be increased by suppressing resonance with the adaptive tuning mode or machine resonance suppression filter and then executing steps 3 to 8.	Suppression of machine resonance Refer to section 7.2 and 7.3.
10	While checking the settling characteristic and motor status, fine-adjust each gain.	Fine adjustment

(c) Parameter adjustment

1) [Pr. PB09 Speed loop gain]

This parameter determines the response level of the speed control loop. Increasing this value enhances response but a too high value will make the mechanical system liable to vibrate. The actual response frequency of the speed loop is as indicated in the following expression.

$$\text{Speed loop response frequency [Hz]} = \frac{\text{Speed loop gain}}{(1 + \text{Load to motor inertia ratio}) \times 2\pi}$$

2) [Pr. PB10 Speed integral compensation]

To eliminate stationary deviation against a command, the speed control loop is under proportional integral control. For the speed integral compensation, set the time constant of this integral control. Increasing the setting lowers the response level. However, if the load to motor inertia ratio is large or the mechanical system has any vibratory element, the mechanical system is liable to vibrate unless the setting is increased to some degree. The guideline is as indicated in the following expression.

$$\begin{aligned} & \text{Speed integral compensation setting [ms]} \\ & \geq \frac{2000 \text{ to } 3000}{\text{Speed loop gain}/(1 + \text{Load to motor inertia ratio})} \end{aligned}$$

6. NORMAL GAIN ADJUSTMENT

3) [Pr. PB08 Position loop gain]

This parameter determines the response level to a disturbance to the position control loop. Increasing the value increases the response level to the disturbance, but a too high value will increase vibration of the mechanical system.

$$\text{Position loop gain guideline} \leq \frac{\text{Speed loop gain}}{(1 + \text{Load to motor inertia ratio})} \times \left(\frac{1}{4} \text{ to } \frac{1}{8} \right)$$

4) [Pr. PB07 Model loop gain]

This parameter determines the response level to a position command. Increasing the value improves track ability to a position command, but a too high value will make overshoot liable to occur at settling.

$$\text{Model loop gain guideline} \leq \frac{\text{Speed loop gain}}{(1 + \text{Load to motor inertia ratio})} \times \left(\frac{1}{4} \text{ to } \frac{1}{8} \right)$$

6.5 2 gain adjustment mode

The 2 gain adjustment mode is used to match the position loop gains of the axes when performing the interpolation operation of servo motors of two or more axes for an X-Y table or the like. In this mode, manually set the model loop gain that determines command track ability. Other parameters for gain adjustment are set automatically.

(1) 2 gain adjustment mode 1 (interpolation mode)

The 2 gain adjustment mode 1 manually set the model loop gain that determines command track ability. The mode constantly estimates the load to motor inertia ratio, and automatically set other parameters for gain adjustment to optimum gains using auto tuning response.

The following parameters are used for 2 gain adjustment mode 1.

(a) Automatically adjusted parameter

The following parameters are automatically adjusted by auto tuning.

Parameter	Symbol	Name
PB06	GD2	Load to motor inertia ratio/load to motor mass ratio
PB08	PG2	Position loop gain
PB09	VG2	Speed loop gain
PB10	VIC	Speed integral compensation

(b) Manually adjusted parameter

The following parameters are adjustable manually.

Parameter	Symbol	Name
PA09	RSP	Auto tuning response
PB07	PG1	Model loop gain

6. NORMAL GAIN ADJUSTMENT

(2) 2 gain adjustment mode 2

Use 2 gain adjustment mode 2 when proper gain adjustment cannot be made with 2 gain adjustment mode 1. Since the load to motor inertia ratio is not estimated in this mode, set the value of a proper load to motor inertia ratio in [Pr. PB06].

The following parameters are used for 2 gain adjustment mode 2.

(a) Automatically adjusted parameter

The following parameters are automatically adjusted by auto tuning.

Parameter	Symbol	Name
PB08	PG2	Position loop gain
PB09	VG2	Speed loop gain
PB10	VIC	Speed integral compensation

(b) Manually adjusted parameter

The following parameters are adjustable manually.

Parameter	Symbol	Name
PA09	RSP	Auto tuning response
PB06	GD2	Load to motor inertia ratio/load to motor mass ratio
PB07	PG1	Model loop gain

(3) Adjustment procedure of 2 gain adjustment mode

POINT
<p>● Set the same value in [Pr. PB07 Model loop gain] for the axis used in 2 gain adjustment mode.</p>

Step	Operation	Description
1	Set to the auto tuning mode.	Select the auto tuning mode 1.
2	During operation, increase the response level setting value in [Pr. PA09], and return the setting if vibration occurs.	Adjustment in auto tuning mode 1.
3	Check value of the model loop gain and the load to motor inertia ratio in advance.	Check the upper setting limits.
4	Set the 2 gain adjustment mode 1 ([Pr. PA08]: ___ 0).	Select the 2 gain adjustment mode 1 (interpolation mode).
5	When the load to motor inertia ratio is different from the design value, select the 2 gain adjustment mode 2 ([Pr. PA08]: ___ 4) and then set the load to motor inertia ratio manually in [Pr. PB06].	Check the load to motor inertia ratio.
6	Set the model loop gain of all the axes to be interpolated to the same value. At that time, adjust to the setting value of the axis, which has the smallest model loop gain.	Set position loop gain.
7	Considering the interpolation characteristic and motor status, fine-adjust the model loop gain and response level setting.	Fine adjustment

6. NORMAL GAIN ADJUSTMENT

(4) Parameter adjustment

[Pr. PB07 Model loop gain]

This parameter determines the response level of the position control loop. Increasing the value improves track ability to a position command, but a too high value will make overshoot liable to occur at settling.

The droop pulse value is determined by the following expression.

$$\text{Number of droop pulses [pulse]} = \frac{\text{Position command frequency [pulse/s]}}{\text{Model loop gain setting}}$$

Position command frequency differs depending on the operation mode.

Rotary servo motor and direct drive motor:

Position command frequency

$$= \frac{\text{Speed [r/min]}}{60} \times \text{Encoder resolution (number of pulses per servo motor revolution)}$$

Linear servo motor:

$$\text{Position command frequency} = \text{Speed [mm/s]} \div \text{Encoder resolution (travel distance per pulse)}$$

7. SPECIAL ADJUSTMENT FUNCTIONS

7. SPECIAL ADJUSTMENT FUNCTIONS

POINT	
●	The functions given in this chapter need not be used normally. Use them if you are not satisfied with the machine status after making adjustment in the methods in chapter 6.
●	When you use a linear servo motor, replace the following left words to the right words.
Load to motor inertia ratio	→ Load to motor mass ratio
Torque	→ Thrust
(Servo motor) speed	→ (Linear servo motor) speed

7.1 Filter setting

The following filters are available with MR-J4 servo amplifiers.

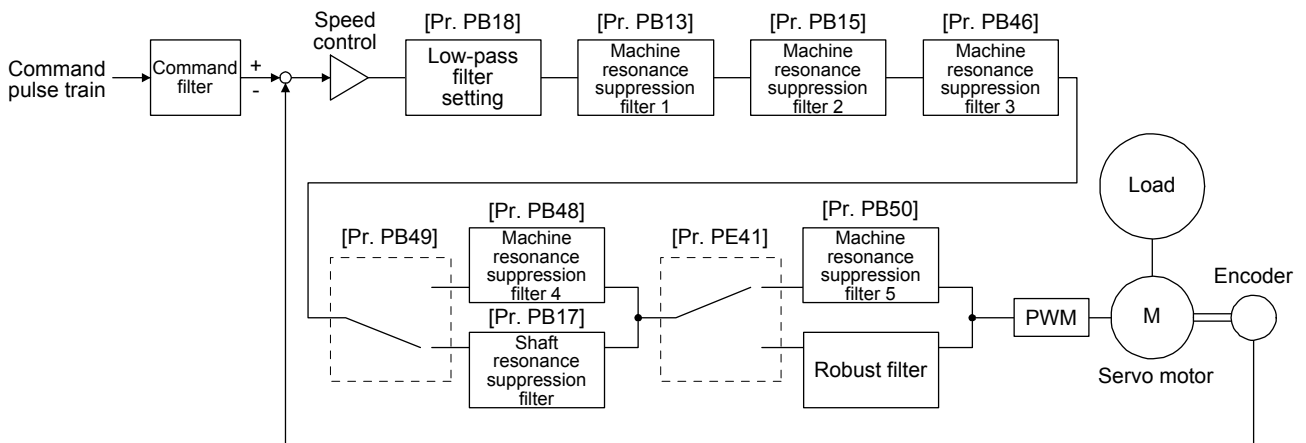

7. SPECIAL ADJUSTMENT FUNCTIONS

7.1.1 Machine resonance suppression filter

POINT
<ul style="list-style-type: none">● The machine resonance suppression filter is a delay factor for the servo system. Therefore, vibration may increase if you set an incorrect resonance frequency or set notch characteristics too deep or too wide.● If the frequency of machine resonance is unknown, decrease the notch frequency from higher to lower ones in order. The optimum notch frequency is set at the point where vibration is minimal.● A deeper notch has a higher effect on machine resonance suppression but increases a phase delay and may increase vibration.● A deeper notch has a higher effect on machine resonance suppression but increases a phase delay and may increase vibration.● The machine characteristic can be grasped beforehand by the machine analyzer on MR Configurator2. This allows the required notch frequency and notch characteristics to be determined.

If a mechanical system has a natural resonance point, increasing the servo system response level may cause the mechanical system to produce resonance (vibration or unusual noise) at that resonance frequency. Using the machine resonance suppression filter and adaptive tuning can suppress the resonance of the mechanical system. The setting range is 10 Hz to 4500 Hz.

7. SPECIAL ADJUSTMENT FUNCTIONS

(1) Function

The machine resonance suppression filter is a filter function (notch filter) which decreases the gain of the specific frequency to suppress the resonance of the mechanical system. You can set the gain decreasing frequency (notch frequency), gain decreasing depth and width.

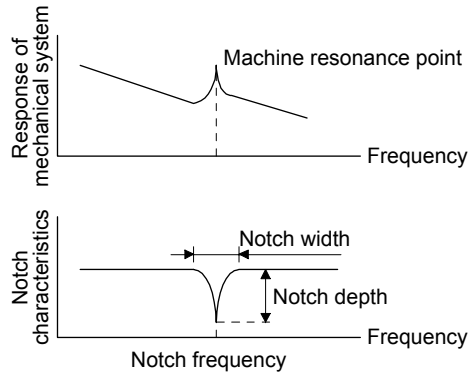

You can set five machine resonance suppression filters at most.

Filter	Setting parameter	Precaution	Parameter that is reset with vibration tough drive function	Parameter automatically adjusted with one-touch tuning	
Machine resonance suppression filter 1	PB01/PB13/PB14	The filter can be set automatically with "Filter tuning mode selection" in [Pr. PB01].	PB13	PB01/PB13/PB14	
Machine resonance suppression filter 2	PB15/PB16		PB15	PB15/PB16	
Machine resonance suppression filter 3	PB46/PB47		PB47		
Machine resonance suppression filter 4	PB48/PB49		Enabling the filter disables the shaft resonance suppression filter. The shaft resonance suppression filter is enabled for the initial setting.		PB48/PB49
Machine resonance suppression filter 5	PB50/PB51		The setting of this filter is disabled while you use the robust filter. The robust filter is disabled for the initial setting.		PB51

7. SPECIAL ADJUSTMENT FUNCTIONS

(2) Parameter

(a) Machine resonance suppression filter 1 ([Pr. PB13] and [Pr. PB14])

Set the notch frequency, notch depth and notch width of the machine resonance suppression filter 1 ([Pr. PB13] and [Pr. PB14])

When you select "Manual setting (_ _ _ 2)" of "Filter tuning mode selection" in [Pr. PB01], the setting of the machine resonance suppression filter 1 is enabled.

(b) Machine resonance suppression filter 2 ([Pr. PB15] and [Pr. PB16])

To use this filter, select "Enabled (_ _ _ 1)" of "Machine resonance suppression filter 2 selection" in [Pr. PB16].

How to set the machine resonance suppression filter 2 ([Pr. PB15] and [Pr. PB16]) is the same as for the machine resonance suppression filter 1 ([Pr. PB13] and [Pr. PB14]).

(c) Machine resonance suppression filter 3 ([Pr. PB46] and [Pr. PB47])

To use this filter, select "Enabled (_ _ _ 1)" of "Machine resonance suppression filter 3 selection" in [Pr. PB47].

How to set the machine resonance suppression filter 3 ([Pr. PB46] and [Pr. PB47]) is the same as for the machine resonance suppression filter 1 ([Pr. PB13] and [Pr. PB14]).

(d) Machine resonance suppression filter 4 ([Pr. PB48] and [Pr. PB49])

To use this filter, select "Enabled (_ _ _ 1)" of "Machine resonance suppression filter 4 selection" in [Pr. PB49]. However, enabling the machine resonance suppression filter 4 disables the shaft resonance suppression filter.

How to set the machine resonance suppression filter 4 ([Pr. PB48] and [Pr. PB49]) is the same as for the machine resonance suppression filter 1 ([Pr. PB13] and [Pr. PB14]).

(e) Machine resonance suppression filter 5 ([Pr. PB50] and [Pr. PB51])

To use this filter, select "Enabled (_ _ _ 1)" of "Machine resonance suppression filter 5 selection" in [Pr. PB51]. However, enabling the robust filter ([Pr. PE41: _ _ _ 1]) disables the machine resonance suppression filter 5.

How to set the machine resonance suppression filter 5 ([Pr. PB50] and [Pr. PB51]) is the same as for the machine resonance suppression filter 1 ([Pr. PB13] and [Pr. PB14]).

7. SPECIAL ADJUSTMENT FUNCTIONS

7.1.2 Adaptive filter II

POINT
<ul style="list-style-type: none"> ● The machine resonance frequency which adaptive filter II (adaptive tuning) can respond to is about 100 Hz to 2.25 kHz. As for the resonance frequency out of the range, set manually. ● When adaptive tuning is executed, vibration sound increases as an excitation signal is forcibly applied for several seconds. ● When adaptive tuning is executed, machine resonance is detected for a maximum of 10 seconds and a filter is generated. After filter generation, the adaptive tuning mode automatically shifts to the manual setting. ● Adaptive tuning generates the optimum filter with the currently set control gains. If vibration occurs when the response setting is increased, execute adaptive tuning again. ● During adaptive tuning, a filter having the best notch depth at the set control gain is generated. To allow a filter margin against machine resonance, increase the notch depth in the manual setting. ● Adaptive vibration suppression control may provide no effect on a mechanical system which has complex resonance characteristics.

(1) Function

Adaptive filter II (adaptive tuning) is a function in which the servo amplifier detects machine vibration for a predetermined period of time and sets the filter characteristics automatically to suppress mechanical system vibration. Since the filter characteristics (frequency, depth) are set automatically, you need not be conscious of the resonance frequency of a mechanical system.

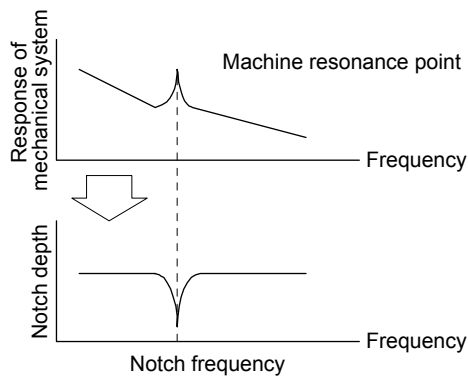

When machine resonance is large and frequency is low

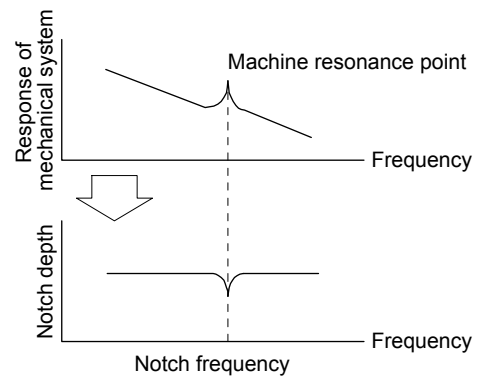

When machine resonance is small and frequency is high

(2) Parameter

Select how to set the filter tuning in [Pr. PB01 Adaptive tuning mode (adaptive filter II)].

[Pr. PB01]

0	0	0	
---	---	---	--

Filter tuning mode selection

Setting value	Filter tuning mode selection	Automatically set parameter
0	Disabled	
1	Automatic setting	PB13/PB14
2	Manual setting	

7. SPECIAL ADJUSTMENT FUNCTIONS

(3) Adaptive tuning mode procedure

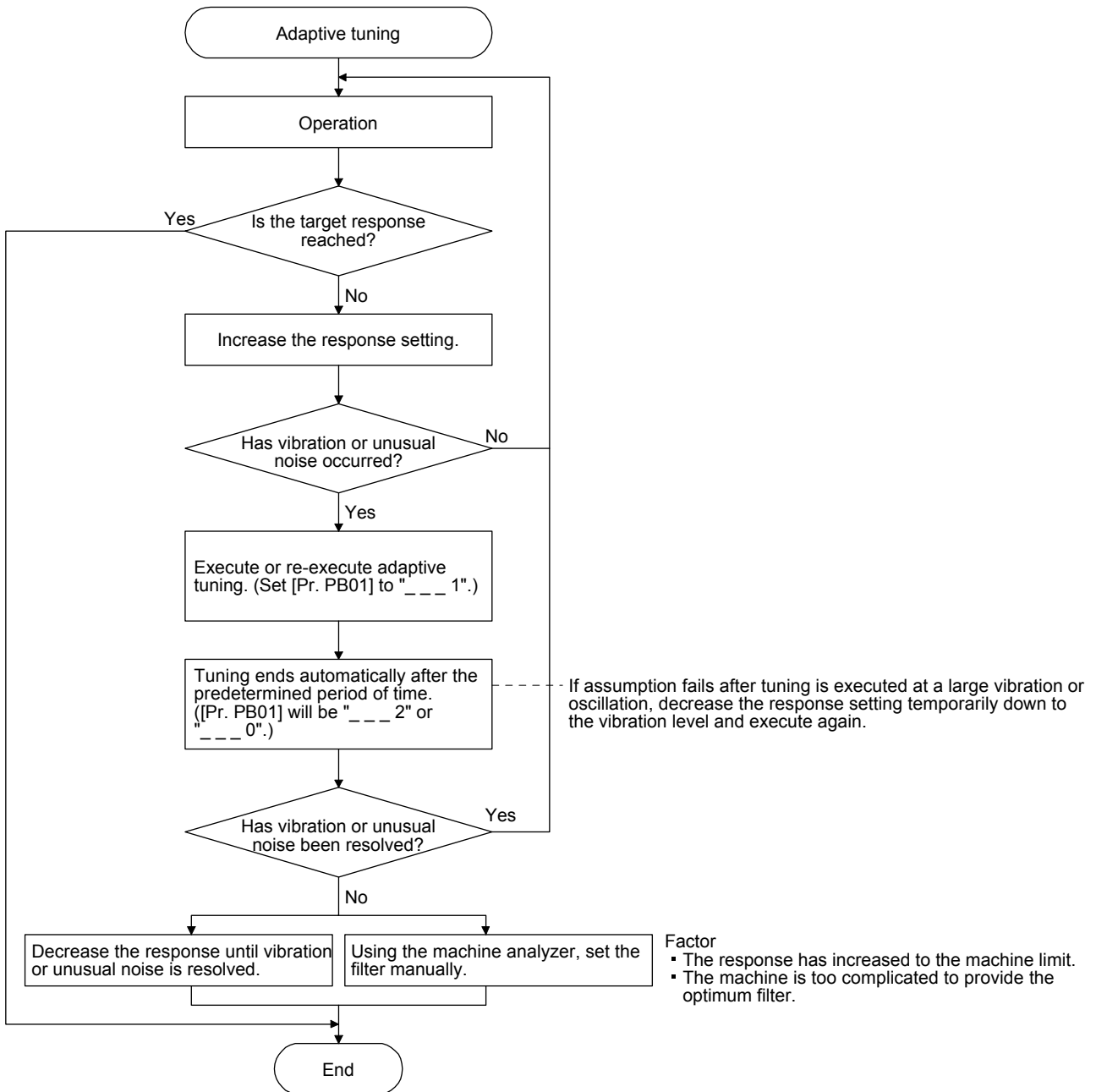

7. SPECIAL ADJUSTMENT FUNCTIONS

7.1.3 Shaft resonance suppression filter

(1) Function

When a load is mounted to the servo motor shaft, resonance by shaft torsion during driving may generate a mechanical vibration at high frequency. The shaft resonance suppression filter suppresses the vibration.

When you select "Automatic setting", the filter will be set automatically on the basis of the motor you use and the load to motor inertia ratio. The disabled setting increases the response of the servo amplifier for high resonance frequency.

(2) Parameter

Set "Shaft resonance suppression filter selection" in [Pr. PB23].

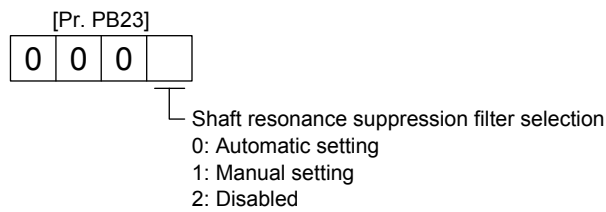

To set [Pr. PB17 Shaft resonance suppression filter] automatically, select "Automatic setting".

To set [Pr. PB17 Shaft resonance suppression filter] manually, select "Manual setting". The setting values are as follows.

Shaft resonance suppression filter setting frequency selection

Setting value	Frequency [Hz]	Setting value	Frequency [Hz]
__ 0 0	Disabled	__ 1 0	562
__ 0 1	Disabled	__ 1 1	529
__ 0 2	4500	__ 1 2	500
__ 0 3	3000	__ 1 3	473
__ 0 4	2250	__ 1 4	450
__ 0 5	1800	__ 1 5	428
__ 0 6	1500	__ 1 6	409
__ 0 7	1285	__ 1 7	391
__ 0 8	1125	__ 1 8	375
__ 0 9	1000	__ 1 9	360
__ 0 A	900	__ 1 A	346
__ 0 B	818	__ 1 B	333
__ 0 C	750	__ 1 C	321
__ 0 D	692	__ 1 D	310
__ 0 E	642	__ 1 E	300
__ 0 F	600	__ 1 F	290

7. SPECIAL ADJUSTMENT FUNCTIONS

7.1.4 Low-pass filter

(1) Function

When a ball screw or the like is used, resonance of high frequency may occur as the response level of the servo system is increased. To prevent this, the low-pass filter is enabled for a torque command as a default. The filter frequency of the low-pass filter is automatically adjusted to the value in the following equation.

$$\text{Filter frequency ([rad/s])} = \frac{VG2}{1 + GD2} \times 10$$

To set [Pr. PB18] manually, select "Manual setting (_ _ 1 _)" of "Low-pass filter selection" in [Pr. PB23].

(2) Parameter

Set "Low-pass filter selection" in [Pr. PB23].

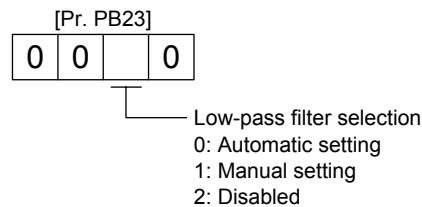

7.1.5 Advanced vibration suppression control II

POINT
● The function is enabled when "Gain adjustment mode selection" in [Pr. PA08] is "Auto tuning mode 2 (_ _ _ 2)", "Manual mode (_ _ _ 3)", or "2 gain adjustment mode 2 (_ _ _ 4)".
● The machine resonance frequency supported in the vibration suppression control tuning mode is 1.0 Hz to 100.0 Hz. As for the vibration out of the range, set manually.
● Stop the servo motor before changing the vibration suppression control-related parameters. Otherwise, it may cause an unexpected operation.
● For positioning operation during execution of vibration suppression control tuning, provide a stop time to ensure a stop after vibration damping.
● Vibration suppression control tuning may not make normal estimation if the residual vibration at the servo motor side is small.
● Vibration suppression control tuning sets the optimum parameter with the currently set control gains. When the response setting is increased, set vibration suppression control tuning again.
● When using the vibration suppression control 2, set " _ _ _ 1" in [Pr. PA24].

7. SPECIAL ADJUSTMENT FUNCTIONS

(1) Function

Vibration suppression control is used to further suppress load-side vibration, such as work-side vibration and base shake. The servo motor-side operation is adjusted for positioning so that the machine does not vibrate.

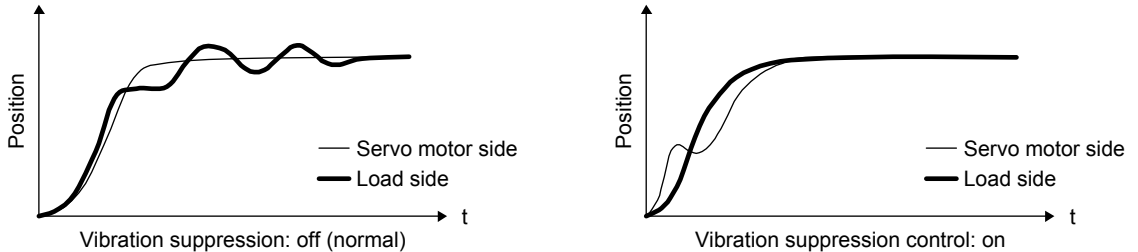

When the advanced vibration suppression control II ([Pr. PB02 Vibration suppression control tuning mode]) is executed, the vibration frequency at load side is automatically estimated to suppress machine side vibration two times at most.

In the vibration suppression control tuning mode, this mode shifts to the manual setting after the positioning operation is performed the predetermined number of times. For manual setting, adjust the vibration suppression control 1 with [Pr. PB19] to [Pr. PB22] and vibration suppression control 2 with [Pr. PB52] to [Pr. PB55].

(2) Parameter

Set [Pr. PB02 Vibration suppression control tuning mode (advanced vibration suppression control II)]. When you use a vibration suppression control, set "Vibration suppression control 1 tuning mode selection". When you use two vibration suppression controls, set "Vibration suppression control 2 tuning mode selection" in addition.

[Pr. PB02]
0 0

Vibration suppression control 1 tuning mode

Setting value	Vibration suppression control 1 tuning mode selection	Automatically set parameter
__ _ 0	Disabled	
__ _ 1	Automatic setting	PB19/PB20/PB21/PB22
__ _ 2	Manual setting	

Vibration suppression control 2 tuning mode

Setting value	Vibration suppression control 2 tuning mode selection	Automatically set parameter
__ 0 _	Disabled	
__ 1 _	Automatic setting	PB52/PB53/PB54/PB55
__ 2 _	Manual setting	

7. SPECIAL ADJUSTMENT FUNCTIONS

(3) Vibration suppression control tuning procedure

The following flow chart is for the vibration suppression control 1. For the vibration suppression control 2, set " __ 1 _" in [Pr. PB02] to execute the vibration suppression control tuning.

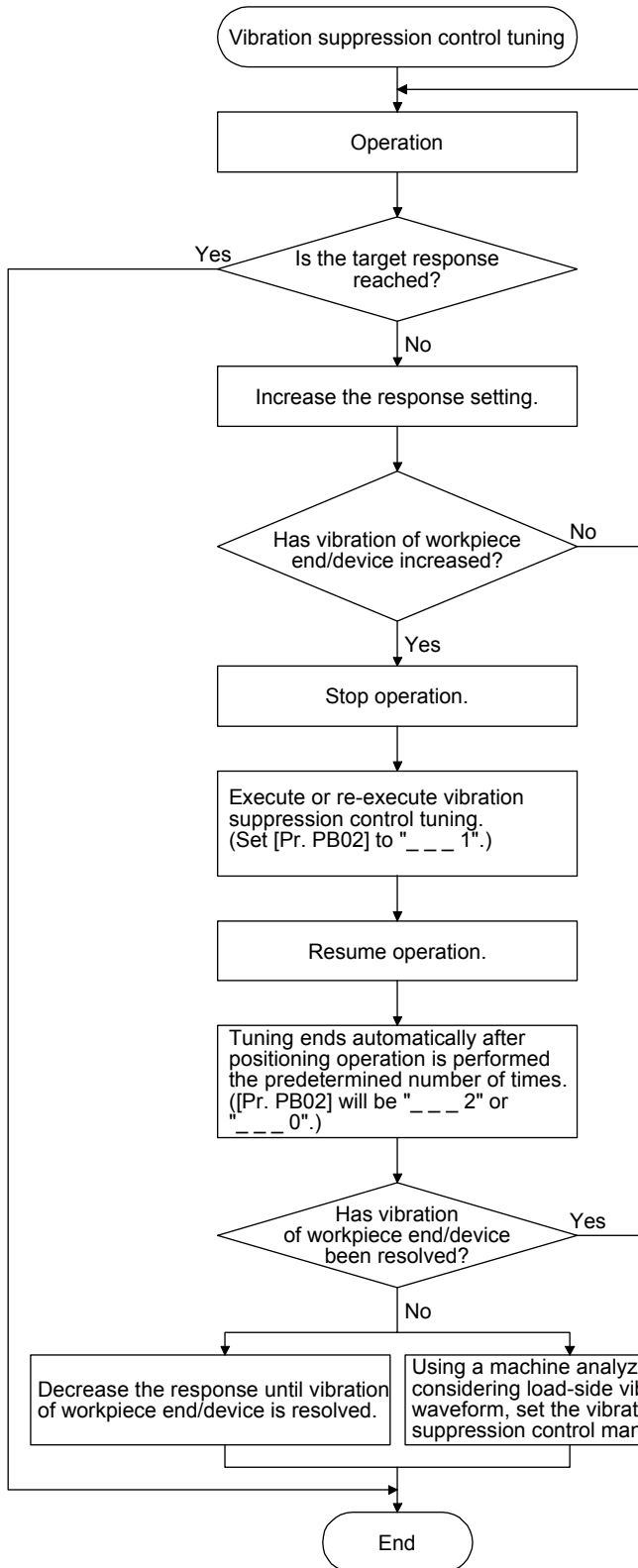

Factor

- Estimation cannot be made as load-side vibration has not been transmitted to the servo motor side.
- The response of the model loop gain has increased to the load-side vibration frequency (vibration suppression control limit).

7. SPECIAL ADJUSTMENT FUNCTIONS

(4) Vibration suppression control manual mode

POINT	
	<ul style="list-style-type: none"> ● When load-side vibration does not show up in servo motor-side vibration, the setting of the servo motor-side vibration frequency does not produce an effect. ● When the anti-resonance frequency and resonance frequency can be confirmed using the machine analyzer or external equipment, do not set the same value but set different values to improve the vibration suppression performance. ● A vibration suppression control effect is not produced if the relation between the [Pr. PB07 Model loop gain] value and vibration frequency is as follows. Vibration suppression control 1: $[\text{Pr. PB19}] < \frac{1}{2\pi} (0.9 \times [\text{Pr. PB07}])$ $[\text{Pr. PB20}] < \frac{1}{2\pi} (0.9 \times [\text{Pr. PB07}])$ Vibration suppression control 2: $[\text{Pr. PB19}] < [\text{Pr. PB52}]$ $[\text{Pr. PB52}] < 5.0 + 0.1 \times [\text{Pr. PB07}]$ $[\text{Pr. PB53}] < 5.0 + 0.1 \times [\text{Pr. PB07}]$ $[\text{Pr. PB07}] < 2\pi \times (0.3 \times [\text{Pr. PB19}] + \frac{1}{8} \times [\text{Pr. PB52}])$ $1.1 < [\text{Pr. PB52}] / [\text{Pr. PB19}] < 5.5$

Measure work-side vibration and device shake with the machine analyzer or external measuring instrument, and set the following parameters to adjust vibration suppression control manually.

Setting item	Vibration suppression control 1	Vibration suppression control 2
Vibration suppression control - Vibration frequency	[Pr. PB19]	[Pr. PB52]
Vibration suppression control - Resonance frequency	[Pr. PB20]	[Pr. PB53]
Vibration suppression control - Vibration frequency damping	[Pr. PB21]	[Pr. PB54]
Vibration suppression control - Resonance frequency damping	[Pr. PB22]	[Pr. PB55]

7. SPECIAL ADJUSTMENT FUNCTIONS

Step 1 Select "Manual setting (_ _ 2)" of "Vibration suppression control 1 tuning mode selection" or "Manual setting (_ _ 2 _)" of "Vibration suppression control 2 tuning mode selection" in [Pr. PB02].

Step 2 Set "Vibration suppression control - Vibration frequency" and "Vibration suppression control - Resonance frequency" as follows.

(a) When a vibration peak can be confirmed with machine analyzer using MR Configurator2, or external equipment.

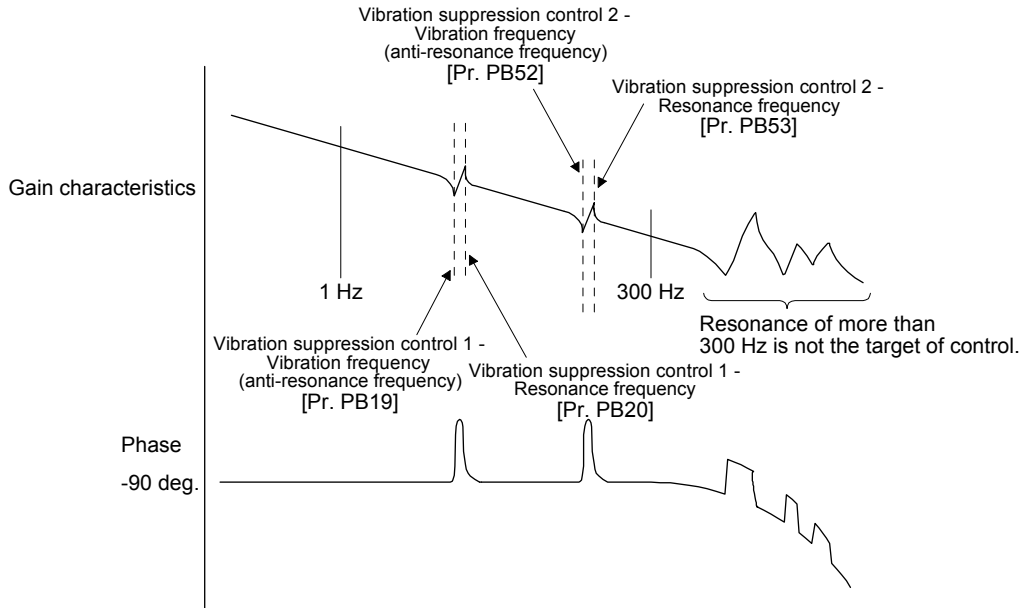

(b) When vibration can be confirmed using monitor signal or external sensor

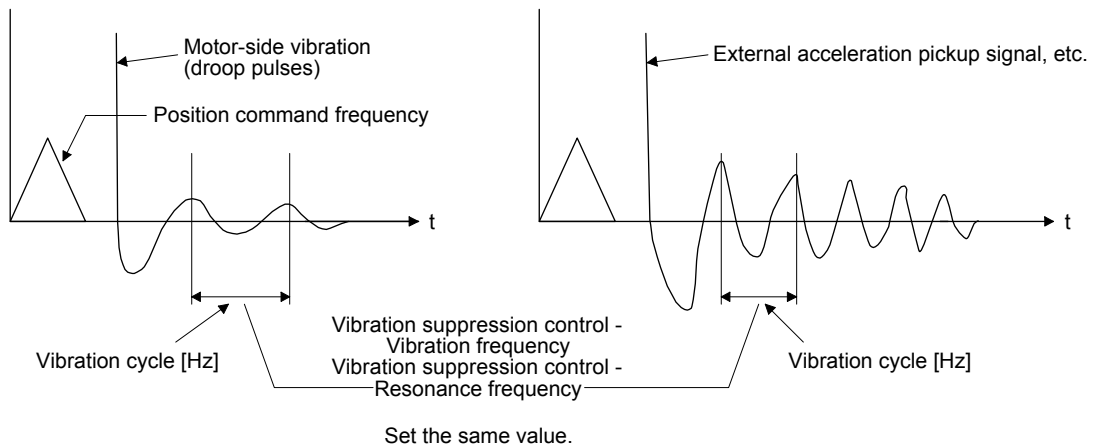

Step 3 Fine-adjust "Vibration suppression control - Vibration frequency damping" and "Vibration suppression control - Resonance frequency damping".

7. SPECIAL ADJUSTMENT FUNCTIONS

7.1.6 Command notch filter

POINT
●By using the advanced vibration suppression control II and the command notch filter, the load-side vibration of three frequencies can be suppressed.
●The frequency range of machine vibration, which can be supported by the command notch filter, is between 4.5 Hz and 2250 Hz. Set a frequency close to the machine vibration frequency and within the range.
●When [Pr. PB45 Command notch filter] is changed during the positioning operation, the changed setting is not reflected. The setting is reflected approximately 150 ms after the servo motor stops (after servo-lock).

(1) Function

Command notch filter has a function that lowers the gain of the specified frequency contained in a position command. By lowering the gain, load-side vibration, such as work-side vibration and base shake, can be suppressed. Which frequency to lower the gain and how deep to lower the gain can be set.

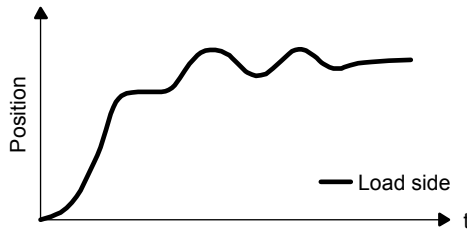

Command notch filter: disabled

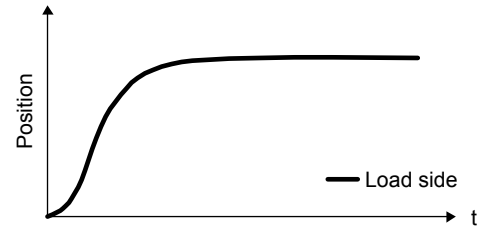

Command notch filter: enabled

7. SPECIAL ADJUSTMENT FUNCTIONS

(2) Parameter

Set [Pr. PB45 Command notch filter] as shown below. For the command notch filter setting frequency, set the closest value to the vibration frequency [Hz] at the load side.

[Pr. PB45]

0			
---	--	--	--

Notch depth

Setting value	Depth [dB]
0	-40.0
1	-24.1
2	-18.1
3	-14.5
4	-12.0
5	-10.1
6	-8.5
7	-7.2
8	-6.0
9	-5.0
A	-4.1
B	-3.3
C	-2.5
D	-1.8
E	-1.2
F	-0.6

Command notch filter setting frequency

Setting value	Frequency [Hz]	Setting value	Frequency [Hz]	Setting value	Frequency [Hz]
00	Disabled	20	70	40	17.6
01	2250	21	66	41	16.5
02	1125	22	62	42	15.6
03	750	23	59	43	14.8
04	562	24	56	44	14.1
05	450	25	53	45	13.4
06	375	26	51	46	12.8
07	321	27	48	47	12.2
08	281	28	46	48	11.7
09	250	29	45	49	11.3
0A	225	2A	43	4A	10.8
0B	204	2B	41	4B	10.4
0C	187	2C	40	4C	10.0
0D	173	2D	38	4D	9.7
0E	160	2E	37	4E	9.4
0F	150	2F	36	4F	9.1
10	140	30	35.2	50	8.8
11	132	31	33.1	51	8.3
12	125	32	31.3	52	7.8
13	118	33	29.6	53	7.4
14	112	34	28.1	54	7.0
15	107	35	26.8	55	6.7
16	102	36	25.6	56	6.4
17	97	37	24.5	57	6.1
18	93	38	23.4	58	5.9
19	90	39	22.5	59	5.6
1A	86	3A	21.6	5A	5.4
1B	83	3B	20.8	5B	5.2
1C	80	3C	20.1	5C	5.0
1D	77	3D	19.4	5D	4.9
1E	75	3E	18.8	5E	4.7
1F	72	3F	18.2	5F	4.5

7. SPECIAL ADJUSTMENT FUNCTIONS

7.2 Gain switching function

You can switch gains with the function. You can switch gains during rotation and during stop, and can use a control command from a controller to switch gains during operation.

7.2.1 Applications

The following shows when you use the function.

- (1) You want to increase the gains during servo-lock but decrease the gains to reduce noise during rotation.
- (2) You want to increase the gains during settling to shorten the stop settling time.
- (3) You want to change the gains using a control command from a controller to ensure stability of the servo system since the load to motor inertia ratio varies greatly during a stop (e.g. a large load is mounted on a carrier).

7. SPECIAL ADJUSTMENT FUNCTIONS

7.2.2 Function block diagram

The control gains, load to motor inertia ratio, and vibration suppression control settings are changed according to the conditions selected by [Pr. PB26 Gain switching function] and [Pr. PB27 Gain switching condition].

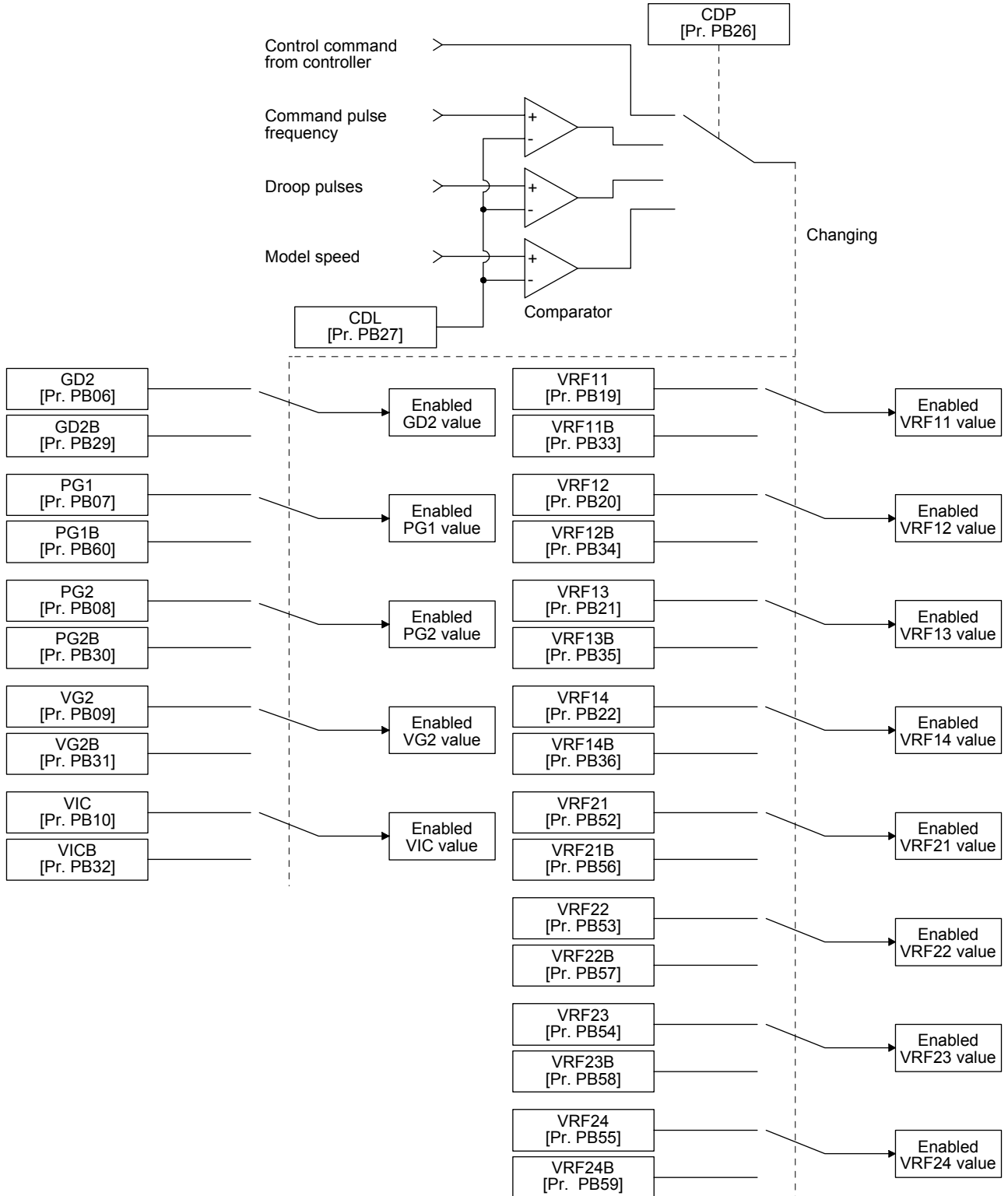

7. SPECIAL ADJUSTMENT FUNCTIONS

7.2.3 Parameter

When using the gain switching function, always select "Manual mode (_ _ _ 3)" of "Gain adjustment mode selection" in [Pr. PA08 Auto tuning mode]. The gain switching function cannot be used in the auto tuning mode.

(1) Variable gain operation setting parameter

Parameter	Symbol	Name	Unit	Description
PB26	CDP	Gain switching selection		Used to select the changing condition.
PB27	CDL	Gain switching condition	[kpps] /[pulse] /[r/min]	Used to set the changing condition values.
PB28	CDT	Gain switching time constant	[ms]	You can set the filter time constant for a gain change at changing.

(a) [Pr. PB26 Gain switching function]

Used to set the gain switching condition. Select the switching condition in the first digit and second digit.

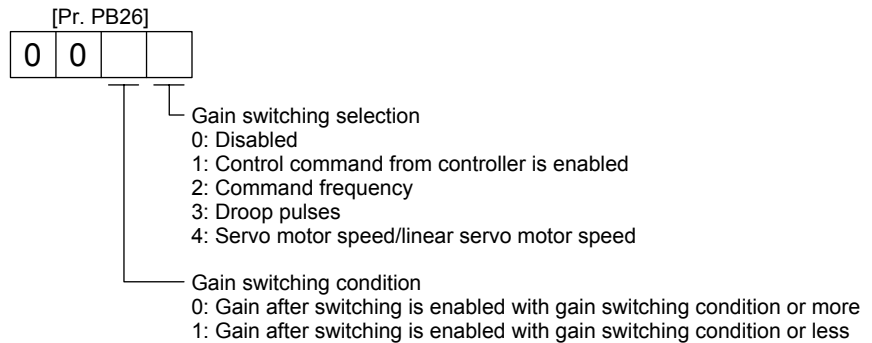

(b) [Pr. PB27 Gain switching condition]

Set a level to switch gains after you select "Command frequency", "Droop pulses", or "Servo motor speed/linear servo motor speed" in [Pr. PB26 Gain switching function].

The setting unit is as follows.

Gain switching condition	Unit
Command frequency	[kpps]
Droop pulses	[pulse]
Servo motor speed/linear servo motor speed	[r/min]/[mm/s]

(c) [Pr. PB28 Gain switching time constant]

You can set the primary delay filter to each gain at gain switching. This parameter is used to suppress shock given to the machine if the gain difference is large at gain switching, for example.

7. SPECIAL ADJUSTMENT FUNCTIONS

(2) Switchable gain parameter

Loop gain	Before switching			After switching		
	Parameter	Symbol	Name	Parameter	Symbol	Name
Load to motor inertia ratio/load to motor mass ratio	PB06	GD2	Load to motor inertia ratio/load to motor mass ratio	PB29	GD2B	Load to motor inertia ratio/load to motor mass ratio after gain switching
Model loop gain	PB07	PG1	Model loop gain	PB60	PG1B	Model loop gain after gain switching
Position loop gain	PB08	PG2	Position loop gain	PB30	PG2B	Position loop gain after gain switching
Speed loop gain	PB09	VG2	Speed loop gain	PB31	VG2B	Speed loop gain after gain switching
Speed integral compensation	PB10	VIC	Speed integral compensation	PB32	VICB	Speed integral compensation after gain switching
Vibration suppression control 1 - Vibration frequency	PB19	VRF11	Vibration suppression control 1 - Vibration frequency	PB33	VRF11B	Vibration suppression control 1 - Vibration frequency after gain switching
Vibration suppression control 1 - Resonance frequency	PB20	VRF12	Vibration suppression control 1 - Resonance frequency	PB34	VRF12B	Vibration suppression control 1 - Resonance frequency after gain switching
Vibration suppression control 1 - Vibration frequency damping	PB21	VRF13	Vibration suppression control 1 - Vibration frequency damping	PB35	VRF13B	Vibration suppression control 1 - Vibration frequency damping after gain switching
Vibration suppression control 1 - Resonance frequency damping	PB22	VRF14	Vibration suppression control 1 - Resonance frequency damping	PB36	VRF14B	Vibration suppression control 1 - Resonance frequency damping after gain switching
Vibration suppression control 2 - Vibration frequency	PB52	VRF21	Vibration suppression control 2 - Vibration frequency	PB56	VRF21B	Vibration suppression control 2 - Vibration frequency after gain switching
Vibration suppression control 2 - Resonance frequency	PB53	VRF22	Vibration suppression control 2 - Resonance frequency	PB57	VRF22B	Vibration suppression control 2 - Resonance frequency after gain switching
Vibration suppression control 2 - Vibration frequency damping	PB54	VRF23	Vibration suppression control 2 - Vibration frequency damping	PB58	VRF23B	Vibration suppression control 2 - Vibration frequency damping after gain switching
Vibration suppression control 2 - Resonance frequency damping	PB55	VRF24	Vibration suppression control 2 - Resonance frequency damping	PB59	VRF24B	Vibration suppression control 2 - Resonance frequency damping after gain switching

(a) [Pr. PB06] to [Pr. PB10]

These parameters are the same as in ordinary manual adjustment. Gain switching allows the values of load to motor inertia ratio/load to motor mass ratio, position loop gain, speed loop gain, and speed integral compensation to be switched.

(b) [Pr. PB19] to [Pr. PB22]/[Pr. PB52] to [Pr. PB55]

These parameters are the same as in ordinary manual adjustment. Executing gain switching while the servo motor stops, You can change vibration frequency, resonance frequency, vibration frequency damping, and resonance frequency damping.

7. SPECIAL ADJUSTMENT FUNCTIONS

- (c) [Pr. PB29 Load to motor inertia ratio/load to motor mass ratio after gain switching]
Set the load to motor inertia ratio or load to motor mass ratio after gain switching. If the load to motor inertia ratio does not change, set it to the same value as [Pr. PB06 Load to motor inertia ratio/load to motor mass ratio].
- (d) [Pr. PB30 Position loop gain after gain switching], [Pr. PB31 Speed loop gain after gain switching], and [Pr. PB32 Speed integral compensation after gain switching]
Set the values of after switching position loop gain, speed loop gain and speed integral compensation.
- (e) Vibration suppression control after gain switching ([Pr. PB33] to [Pr. PB36]/[Pr. PB56] to [Pr. PB59]), and [Pr. PB60 Model loop gain after gain switching]
The gain switching vibration suppression control and model loop gain are used only with control command from the controller.
You can switch the vibration frequency, resonance frequency, vibration frequency damping, resonance frequency damping, and model loop gain of the vibration suppression control 1 and vibration suppression control 2.

7. SPECIAL ADJUSTMENT FUNCTIONS

7.2.4 Gain switching procedure

This operation will be described by way of setting examples.

(1) When you choose switching by control command from the controller

(a) Setting

Parameter	Symbol	Name	Setting value	Unit
PB06	GD2	Load to motor inertia ratio/load to motor mass ratio	4.00	[Multiplier]
PB07	PG1	Model loop gain	100	[rad/s]
PB08	PG2	Position loop gain	120	[rad/s]
PB09	VG2	Speed loop gain	3000	[rad/s]
PB10	VIC	Speed integral compensation	20	[ms]
PB19	VRF11	Vibration suppression control 1 - Vibration frequency	50	[Hz]
PB20	VRF12	Vibration suppression control 1 - Resonance frequency	50	[Hz]
PB21	VRF13	Vibration suppression control 1 - Vibration frequency damping	0.20	
PB22	VRF14	Vibration suppression control 1 - Resonance frequency damping	0.20	
PB52	VRF21	Vibration suppression control 2 - Vibration frequency	20	[Hz]
PB53	VRF22	Vibration suppression control 2 - Resonance frequency	20	[Hz]
PB54	VRF23	Vibration suppression control 2 - Vibration frequency damping	0.10	
PB55	VRF24	Vibration suppression control 2 - Resonance frequency damping	0.10	
PB29	GD2B	Load to motor inertia ratio/load to motor mass ratio after gain switching	10.00	[Multiplier]
PB60	PG1B	Model loop gain after gain switching	50	[rad/s]
PB30	PG2B	Position loop gain after gain switching	84	[rad/s]
PB31	VG2B	Speed loop gain after gain switching	4000	[rad/s]
PB32	VICB	Speed integral compensation after gain switching	50	[ms]
PB26	CDP	Gain switching function	0001 (Switch by control command from the controller.)	
PB28	CDT	Gain switching time constant	100	[ms]
PB33	VRF11B	Vibration suppression control 1 - Vibration frequency after gain switching	60	[Hz]
PB34	VRF12B	Vibration suppression control 1 - Resonance frequency after gain switching	60	[Hz]
PB35	VRF13B	Vibration suppression control 1 - Vibration frequency damping after gain switching	0.15	
PB36	VRF14B	Vibration suppression control 1 - Resonance frequency damping after gain switching	0.15	
PB56	VRF21B	Vibration suppression control 2 - Vibration frequency after gain switching	30	[Hz]
PB57	VRF22B	Vibration suppression control 2 - Resonance frequency after gain switching	30	[Hz]
PB58	VRF23B	Vibration suppression control 2 - Vibration frequency damping after gain switching	0.05	
PB59	VRF24B	Vibration suppression control 2 - Resonance frequency damping after gain switching	0.05	

7. SPECIAL ADJUSTMENT FUNCTIONS

(b) Switching timing chart

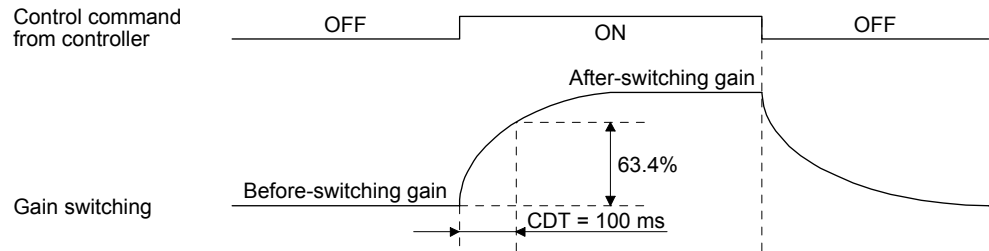

Model loop gain	100	→	50	→	100
Load to motor inertia ratio/load to motor mass ratio	4.00	→	10.00	→	4.00
Position loop gain	120	→	84	→	120
Speed loop gain	3000	→	4000	→	3000
Speed integral compensation	20	→	50	→	20
Vibration suppression control 1 - Vibration frequency	50	→	60	→	50
Vibration suppression control 1 - Resonance frequency	50	→	60	→	50
Vibration suppression control 1 - Vibration frequency damping	0.20	→	0.15	→	0.20
Vibration suppression control 1 - Resonance frequency damping	0.20	→	0.15	→	0.20
Vibration suppression control 2 - Vibration frequency	20	→	30	→	20
Vibration suppression control 2 - Resonance frequency	20	→	30	→	20
Vibration suppression control 2 - Vibration frequency damping	0.10	→	0.05	→	0.10
Vibration suppression control 2 - Resonance frequency damping	0.10	→	0.05	→	0.10

(2) When you choose switching by droop pulses

In this case, the vibration suppression control after gain switching and model loop gain after gain switching cannot be used.

(a) Setting

Parameter	Symbol	Name	Setting value	Unit
PB06	GD2	Load to motor inertia ratio/load to motor mass ratio	4.00	[Multiplier]
PB08	PG2	Position loop gain	120	[rad/s]
PB09	VG2	Speed loop gain	3000	[rad/s]
PB10	VIC	Speed integral compensation	20	[ms]
PB29	GD2B	Load to motor inertia ratio/load to motor mass ratio after gain switching	10.00	[Multiplier]
PB30	PG2B	Position loop gain after gain switching	84	[rad/s]
PB31	VG2B	Speed loop gain after gain switching	4000	[rad/s]
PB32	VICB	Speed integral compensation after gain switching	50	[ms]
PB26	CDP	Gain switching selection	0003 (switching by droop pulses)	
PB27	CDL	Gain switching condition	50	[pulse]
PB28	CDT	Gain switching time constant	100	[ms]

7. SPECIAL ADJUSTMENT FUNCTIONS

(b) Switching timing chart

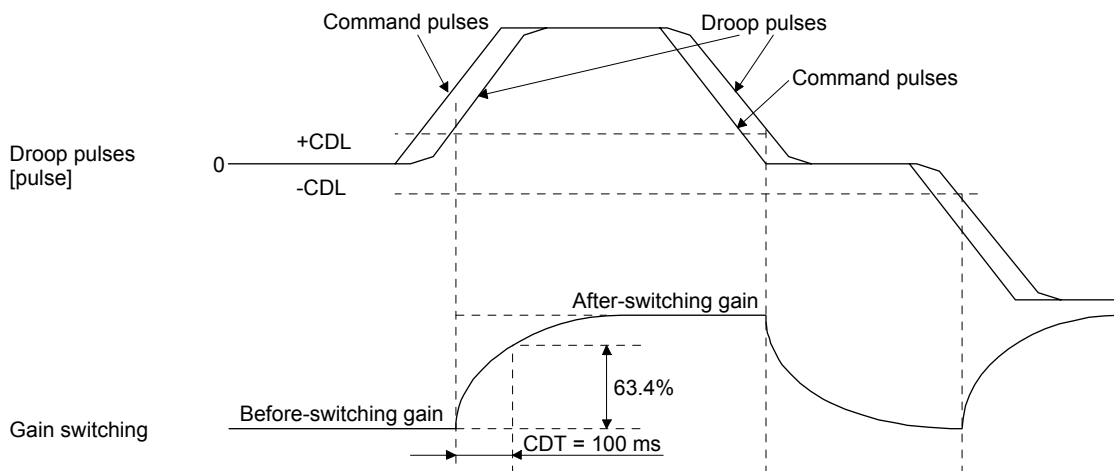

Load to motor inertia ratio/load to motor mass ratio	4.00	→	10.00	→	4.00	→	10.00
Position loop gain	120	→	84	→	120	→	84
Speed loop gain	3000	→	4000	→	3000	→	4000
Speed integral compensation	20	→	50	→	20	→	50

7. SPECIAL ADJUSTMENT FUNCTIONS

7.3 Tough drive function

POINT
●Set enable/disable of the tough drive function with [Pr. PA20 Tough drive setting]. (Refer to section 5.2.1.)

This function makes the equipment continue operating even under the condition that an alarm occurs.

7.3.1 Vibration tough drive function

This function prevent from vibrating by resetting a filter instantaneously when machine resonance occurs due to varied vibration frequency caused machine aging.

To reset the machine resonance suppression filters with the function, [Pr. PB13 Machine resonance suppression filter 1] and [Pr. PB15 Machine resonance suppression filter 2] should be set in advance. Set [Pr. PB13] and [Pr. PB15] as follows.

- (1) One-touch tuning execution (section 6.1)
- (2) Manual setting (section 4.2.2)

The vibration tough drive function operates when a detected machine resonance frequency is within $\pm 30\%$ for a value set in [Pr. PB13 Machine resonance suppression filter 1] or [Pr. PB15 Machine resonance suppression filter 2].

To set a detection level of the function, set sensitivity in [Pr. PF23 Vibration tough drive - Oscillation detection level].

POINT
●Resetting [Pr. PB13] and [Pr. PB15] by the vibration tough drive function is performed constantly. However, the number of write times to the EEPROM is limited to once per hour.
●The vibration tough drive function does not reset [Pr. PB46 Machine resonance suppression filter 3], [Pr. PB48 Machine resonance suppression filter 4], and [Pr. PB50 Machine resonance suppression filter 5].
●The vibration tough drive function does not detect a vibration of 100 Hz or less.

7. SPECIAL ADJUSTMENT FUNCTIONS

The following shows the function block diagram of the vibration tough drive function.

The function detects machine resonance frequency and compare it with [Pr. PB13] and [Pr. PB15], and reset a machine resonance frequency of a parameter whose set value is closer.

Filter	Setting parameter	Precaution	Parameter that is reset with vibration tough drive function
Machine resonance suppression filter 1	PB01/PB13/PB14	The filter can be set automatically with "Filter tuning mode selection" in [Pr. PB01].	PB13
Machine resonance suppression filter 2	PB15/PB16		PB15
Machine resonance suppression filter 3	PB46/PB47		
Machine resonance suppression filter 4	PB48/PB49	Enabling the filter disables the shaft resonance suppression filter. The shaft resonance suppression filter is enabled for the initial setting.	
Machine resonance suppression filter 5	PB50/PB51	The setting of this filter is disabled while you use the robust filter. The robust filter is disabled for the initial setting.	

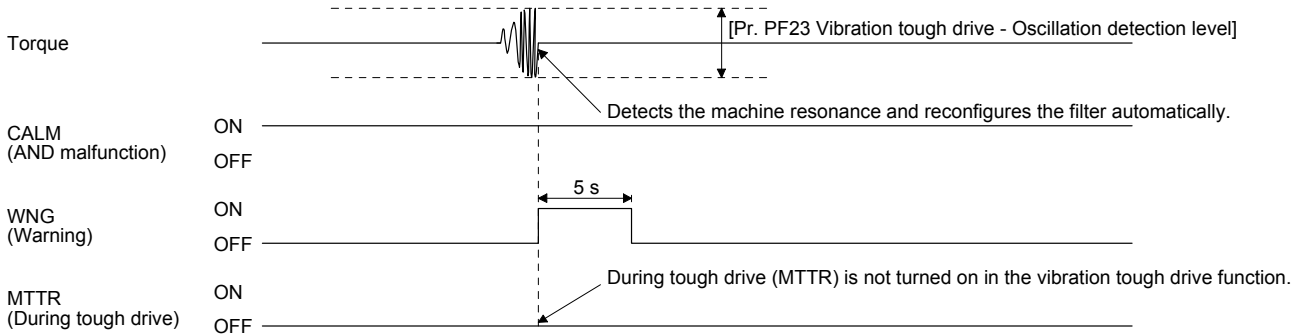
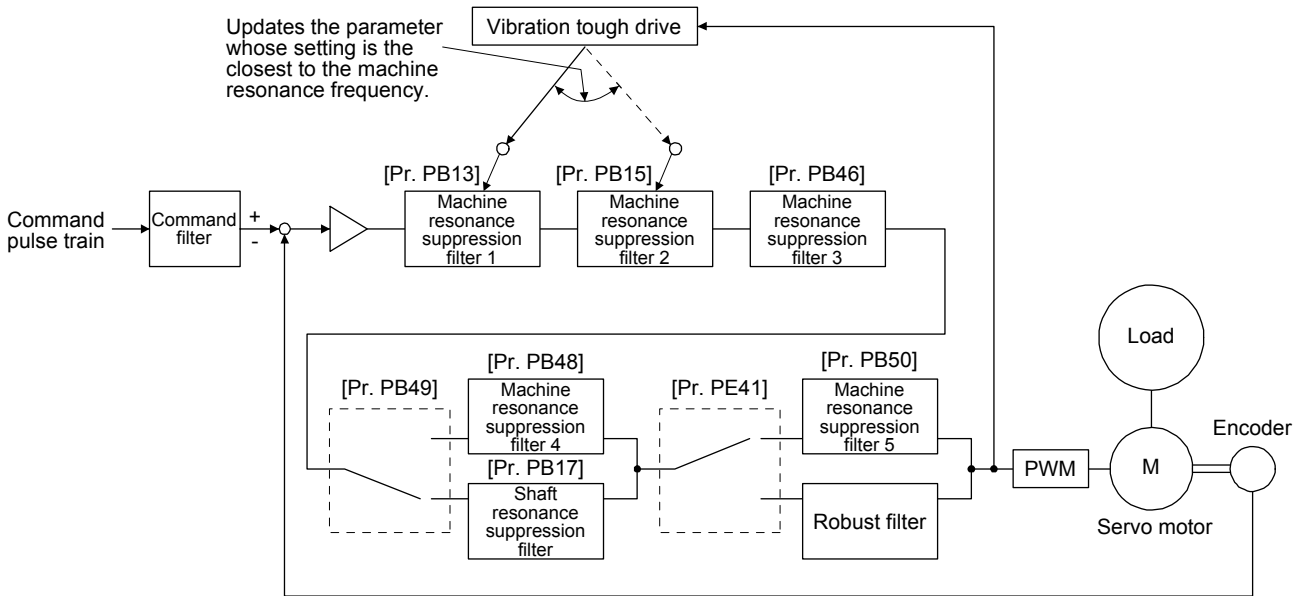

7. SPECIAL ADJUSTMENT FUNCTIONS

7.3.2 Instantaneous power failure tough drive function

The instantaneous power failure tough drive function avoids [AL. 10 Undervoltage] even when an instantaneous power failure occurs during operation. When the instantaneous power failure tough drive activates, the function will increase the immunity to instantaneous power failures using the electrical energy charged in the capacitor in the servo amplifier and will change an alarm level of [AL. 10 Undervoltage] simultaneously. The [AL. 10.1 Voltage drop in the control circuit power] detection time for the control circuit power supply can be changed by [Pr. PF25 SEMI-F47 function - Instantaneous power failure detection time (instantaneous power failure tough drive - detection time)]. In addition, [AL. 10.2 Voltage drop in the main circuit power] detection level for the bus voltage is changed automatically.

POINT
<ul style="list-style-type: none"> ● MBR (Electromagnetic brake interlock) will not turn off during the instantaneous power failure tough drive. ● When the load of instantaneous power failure is large, the undervoltage alarm ([AL. 10.2]) caused by the bus voltage drop may occur regardless of the set value of [Pr. PF25 SEMI-F47 function - Instantaneous power failure detection time (instantaneous power failure tough drive - detection time)].

- (1) Instantaneous power failure time of the control circuit power supply > [Pr. PF25 SEMI-F47 function - Instantaneous power failure detection time (instantaneous power failure tough drive - detection time)]
 The alarm occurs when the instantaneous power failure time of the control circuit power supply exceeds [Pr. PF25 SEMI-F47 function - Instantaneous power failure detection time (instantaneous power failure tough drive - detection time)].

MTTR (During tough drive) turns on after detecting the instantaneous power failure.
 MBR (Electromagnetic brake interlock) turns off when the alarm occurs.

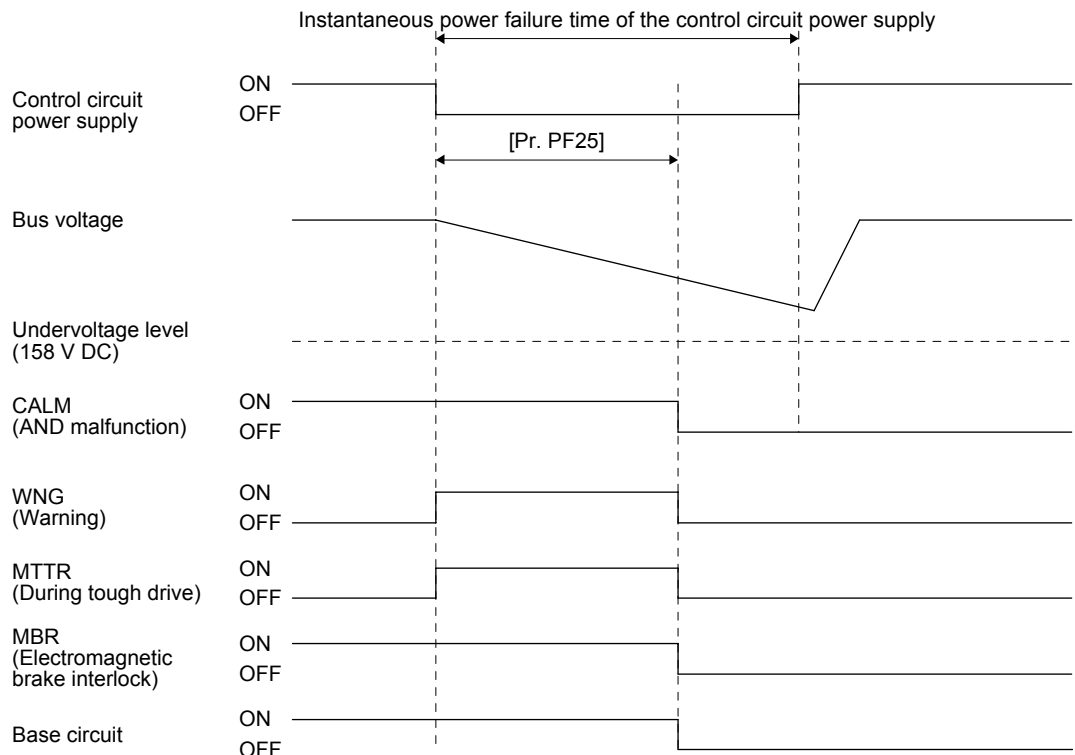

7. SPECIAL ADJUSTMENT FUNCTIONS

(2) Instantaneous power failure time of the control circuit power supply < [Pr. PF25 SEMI-F47 function - Instantaneous power failure detection time (instantaneous power failure tough drive - detection time)]
 Operation status differs depending on how bus voltage decrease.

(a) When the bus voltage decrease lower than 158 V DC within the instantaneous power failure time of the control circuit power supply
 [AL. 10 Undervoltage] occurs when the bus voltage decrease lower than 158 V DC regardless of the enabled instantaneous power failure tough drive.

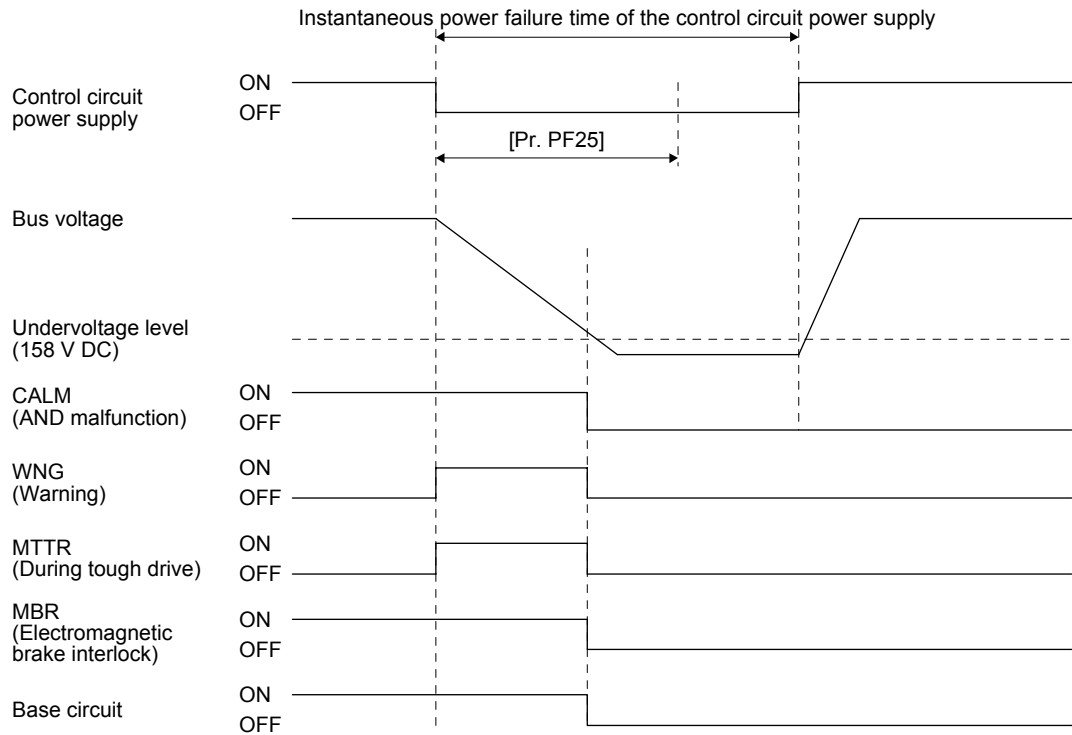

7. SPECIAL ADJUSTMENT FUNCTIONS

- (b) When the bus voltage does not decrease lower than 158 V DC within the instantaneous power failure time of the control circuit power supply
 The operation continues without alarming.

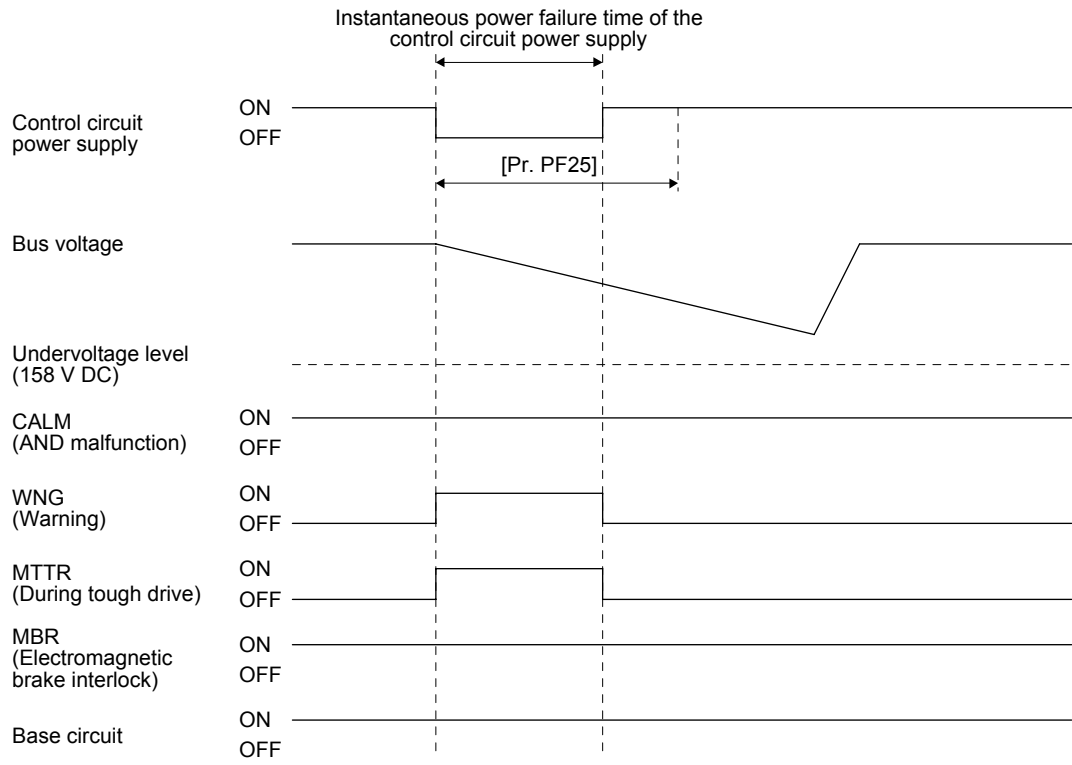

7. SPECIAL ADJUSTMENT FUNCTIONS

7.4 Compliance with SEMI-F47 standard

POINT
<ul style="list-style-type: none"> ● The control circuit power supply of the servo amplifier can be possible to comply with SEMI-F47. However, a back-up capacitor may be necessary for instantaneous power failure in the main circuit power supply depending on the power supply impedance and operating situation. Be sure to check them by testing the entire equipment using actual machines. ● Use a 3-phase for the input power supply of the servo amplifier.

The following explains the compliance with "SEMI-F47 semiconductor process equipment voltage sag immunity test" of MR-J4 series.

(1) Parameter setting

Setting [Pr. PA20] and [Pr. PF25] as follows will enable SEMI-F47.

Parameter	Setting value	Description
PA20	_ 1 _ _	SEMI-F47 selection
PF25	200	Set the time [ms] of the [AL. 10.1 Voltage drop in the control circuit power] occurrence.

Enabling SEMI-F47 will change operation as follows.

- (a) The voltage will drop in the control circuit power with "Rated voltage × 50% or less". 200 ms later, [AL. 10.1 Voltage drop in the control circuit power] will occur.
- (b) [AL. 10.2 Voltage drop in the main circuit power] will occur with 158 V DC or less in bus voltage.
- (c) MBR (Electromagnetic brake interlock) will turn off when [AL. 10.1 Voltage drop in the control circuit power] occurs.

(2) Requirements and recommended conditions of SEMI-F47 standard

Table 7.1 shows the permissible time of instantaneous power failure for instantaneous power failure of SEMI-F47 standard.

Table 7.1 Requirements and recommended conditions of SEMI-F47 standard

Instantaneous power failure voltage	permissible time of instantaneous power failure [s]	
	Requirement	Recommended condition
Rated voltage × 90%	0.5 to 1	10 to 100
Rated voltage × 80%	0.2 to 0.5	0.5 to 10
Rated voltage × 70%	0.05 to 0.2	0.2 to 0.5
Rated voltage × 50%	0.02 to 0.1	0.02 to 0.2
Rated voltage × 0%	0.02 to 0.1	to 0.02

7. SPECIAL ADJUSTMENT FUNCTIONS

(3) Calculation of immunity to instantaneous power failure

Table 7.2 shows immunity to instantaneous power failure when instantaneous power failure voltage is "rated voltage × 50%" and instantaneous power failure time is 200 ms.

Table 7.2 immunity to instantaneous power failure
(instantaneous power failure voltage = rated voltage × 50%,
instantaneous power failure time = 200 ms)

Servo amplifier model	Instantaneous maximum output [W]	Immunity to instantaneous power failure [W] (Voltage drop between lines)
MR-J4W2-22B	1400 (700 × 2)	4000
MR-J4W2-44B	2800 (1400 × 2)	5000
MR-J4W2-77B	5250 (2625 × 2)	10300
MR-J4W2-1010B	6000 (3000 × 2)	10300
MR-J4W3-222B	2100 (700 × 3)	5000
MR-J4W3-444B	4200 (1400 × 3)	7100

Instantaneous maximum output means power which servo amplifier can output in maximum torque at rated speed. You can examine margins to compare the values of following conditions and instantaneous maximum output.

Even if driving at maximum torque with low speed in actual operation, the motor will not drive with the maximum output. This can be handled as a margin.

The following shows the conditions of immunity to instantaneous power failure.

(a) Delta connection

For 3-phase (L1/L2/L3) delta connection, an instantaneous power failure will be applied to a voltage between lines (e.g. between L1 and L2) from three pairs of voltages between lines (between L1 and L2, L2 and L3, or L3 and L1).

(b) Star connection

For 3-phase (L1/L2/L3/neutral point N) star connection, an instantaneous power failure will be applied to a voltage between lines (e.g. between L1 and N) from six pairs of voltages between lines (between L1 and L2, L2 and L3, or L3 and L1) and between line and neutral point (between L1 and N, L2 and N, or L3 and N).

8. TROUBLESHOOTING

8. TROUBLESHOOTING

POINT
<ul style="list-style-type: none"> ● Refer to "MELSERVO-J4 Servo Amplifier Instruction Manual (Troubleshooting)" for details of alarms and warnings. ● If an alarm which indicates each axis in the stop method column occurs, the axis without the alarm operates the servo motor as per normal. ● As soon as an alarm occurs, make the Servo-off status and interrupt the main circuit power.

8.1 Alarm and warning list

When an error occurs during operation, the corresponding alarm or warning is displayed. When the alarm or the warning occurs, refer to "MELSERVO-J4 Servo Amplifier Instruction Manual (Troubleshooting)" to remove the failure. When an alarm occurs, ALM_ (Malfunction for _-axis) will turn off.

After its cause has been removed, the alarm can be deactivated in any of the methods marked ○ in the alarm reset column in the following table. Warnings are automatically canceled after the cause of occurrence is removed.

For the alarms and warnings written "SD" in the stop method column, the axis stops with the dynamic brake after forced stop deceleration. For the alarms and warnings written "DB" or "EDB" in the stop method column, the axis stops with the dynamic brake without forced stop deceleration.

	No.	Name	Detail display	Detail name	Processing system (Note 6)	Stop system	Stop method (Note 4, 5)	Alarm reset			Operation mode			
								Error reset	CPU reset	Power off → on	Standard	Fully closed	Linear	DD
Alarm	10	Undervoltage	10.1	Voltage drop in the control circuit power	Common	All axes	EDB	○	○	○	○	○	○	○
			10.2	Voltage drop in the main circuit power	Common	All axes	SD	○	○	○	○	○	○	○
	11	Switch setting error	11.1	Axis number setting error	Common	All axes	DB	△	△	○	○	○	○	○
			11.2	Disabling control axis setting error	Common	All axes	DB	△	△	○	○	○	○	○
	12	Memory error 1 (RAM)	12.1	RAM error 1	Common	All axes	DB	△	△	○	○	○	○	○
			12.2	RAM error 2	Common	All axes	DB	△	△	○	○	○	○	○
			12.3	RAM error 3	Common	All axes	DB	△	△	○	○	○	○	○
			12.4	RAM error 4	Common	All axes	DB	△	△	○	○	○	○	○
			12.5	RAM error 5	Common	All axes	DB	△	△	○	○	○	○	○
	13	Clock error	13.1	Clock error 1	Common	All axes	DB	△	△	○	○	○	○	○
			13.2	Clock error 2	Common	All axes	DB	△	△	○	○	○	○	○

8. TROUBLESHOOTING

	No.	Name	Detail display	Detail name	Processing system (Note 6)	Stop system	Stop method (Note 4, 5)	Alarm reset			Operation mode			
								Error reset	CPU reset	Power off → on	Standard	Fully closed	Linear	DD
Alarm	14	Control process error	14.1	Control process error 1	Common	All axes	DB	/	/	○	○	○	○	○
			14.2	Control process error 2	Common	All axes	DB	/	/	○	○	○	○	○
			14.3	Control process error 3	Common	All axes	DB	/	/	○	○	○	○	○
			14.4	Control process error 4	Common	All axes	DB	/	/	○	○	○	○	○
			14.5	Control process error 5	Common	All axes	DB	/	/	○	○	○	○	○
			14.6	Control process error 6	Common	All axes	DB	/	/	○	○	○	○	○
			14.7	Control process error 7	Common	All axes	DB	/	/	○	○	○	○	○
			14.8	Control process error 8	Common	All axes	DB	/	/	○	○	○	○	○
			14.9	Control process error 9	Common	All axes	DB	/	/	○	○	○	○	○
			14.A	Control process error 10	Common	All axes	DB	/	/	○	○	○	○	○
	15	Memory error 2 (EEP-ROM)	15.1	EEP-ROM error at power on	Common	All axes	DB	/	/	○	○	○	○	○
			15.2	EEP-ROM error during operation	Common	All axes	DB	/	/	○	○	○	○	○
	16	Encoder initial communication error 1	16.1	Encoder initial communication - Receive data error 1	Each axis	Each axis	DB	/	/	○	○	○	○	○
			16.2	Encoder initial communication - Receive data error 2	Each axis	Each axis	DB	/	/	○	○	○	○	○
			16.3	Encoder initial communication - Receive data error 3	Each axis	Each axis	DB	/	/	○	○	○	○	○
			16.5	Encoder initial communication - Transmission data error 1	Each axis	Each axis	DB	/	/	○	○	○	○	○
			16.6	Encoder initial communication - Transmission data error 2	Each axis	Each axis	DB	/	/	○	○	○	○	○
			16.7	Encoder initial communication - Transmission data error 3	Each axis	Each axis	DB	/	/	○	○	○	○	○
			16.A	Encoder initial communication - Process error 1	Each axis	Each axis	DB	/	/	○	○	○	/	○
			16.B	Encoder initial communication - Process error 2	Each axis	Each axis	DB	/	/	○	○	○	/	○
			16.C	Encoder initial communication - Process error 3	Each axis	Each axis	DB	/	/	○	○	○	/	○
			16.D	Encoder initial communication - Process error 4	Each axis	Each axis	DB	/	/	○	○	○	/	○
	17	Board error	17.1	Board error 1	Common	All axes	DB	/	/	○	○	○	○	○
			17.3	Board error 2	Common	All axes	DB	/	/	○	○	○	○	○
			17.4	Board error 3	Common	All axes	DB	/	/	○	○	○	○	○
			17.5	Board error 4	Common	All axes	DB	/	/	○	○	○	○	○
			17.6	Board error 5	Common	All axes	DB	/	/	○	○	○	○	○
			17.8	Board error 6 (Note 7)	Common	All axes	DB	/	/	○	○	○	○	○

8. TROUBLESHOOTING

	No.	Name	Detail display	Detail name	Processing system (Note 6)	Stop system	Stop method (Note 4, 5)	Alarm reset			Operation mode			
								Error reset	CPU reset	Power off → on	Standard	Fully closed	Linear	DD
Alarm	19	Memory error 3 (Flash ROM)	19.1	Flash-ROM error 1	Common	All axes	DB	/	/	○	○	○	○	○
			19.2	Flash-ROM error 2	Common	All axes	DB	/	/	○	○	○	○	○
	1A	Servo motor combination error	1A.1	Servo motor combination error	Each axis	Each axis	DB	/	/	○	○	○	○	○
			1A.2	Servo motor control mode combination error	Each axis	Each axis	DB	/	/	○	○	○	○	○
	1E	Encoder initial communication error 2	1E.1	Encoder malfunction	Each axis	Each axis	DB	/	/	○	○	○	/	○
			1E.2	Load-side encoder malfunction	Each axis	Each axis	DB	/	/	○	/	○	/	/
	1F	Encoder initial communication error 3	1F.1	Incompatible encoder	Each axis	Each axis	DB	/	/	○	○	○	○	○
			1F.2	Incompatible load-side encoder	Each axis	Each axis	DB	/	/	○	/	○	/	/
	20	Encoder normal communication error 1	20.1	Encoder normal communication - Receive data error 1	Each axis	Each axis	EDB	/	/	○	○	○	○	○
			20.2	Encoder normal communication - Receive data error 2	Each axis	Each axis	EDB	/	/	○	○	○	○	○
			20.3	Encoder normal communication - Receive data error 3	Each axis	Each axis	EDB	/	/	○	○	○	○	○
			20.5	Encoder normal communication - Transmission data error 1	Each axis	Each axis	EDB	/	/	○	○	○	○	○
			20.6	Encoder normal communication - Transmission data error 2	Each axis	Each axis	EDB	/	/	○	○	○	○	○
			20.7	Encoder normal communication - Transmission data error 3	Each axis	Each axis	EDB	/	/	○	○	○	○	○
			20.9	Encoder normal communication - Receive data error 4	Each axis	Each axis	EDB	/	/	○	○	○	○	○
			20.A	Encoder normal communication - Receive data error 5	Each axis	Each axis	EDB	/	/	○	○	○	○	○
	21	Encoder normal communication error 2	21.1	Encoder error 1	Each axis	Each axis	EDB	/	/	○	○	○	/	○
			21.2	Encoder data update error	Each axis	Each axis	EDB	/	/	○	○	○	/	○
			21.3	Encoder data waveform error	Each axis	Each axis	EDB	/	/	○	○	○	/	○
			21.4	Encoder non-signal error	Each axis	Each axis	EDB	/	/	○	/	○	○	/
			21.5	Encoder hardware error 1	Each axis	Each axis	EDB	/	/	○	○	/	/	/
			21.6	Encoder hardware error 2	Each axis	Each axis	EDB	/	/	○	○	/	/	/
			21.9	Encoder error 2	Each axis	Each axis	EDB	/	/	○	○	○	/	○
24	Main circuit error	24.1	Ground fault detected at hardware detection circuit	Each axis	All axes	DB	/	/	○	○	○	○	○	
		24.2	Ground fault detected at software detection function	Each axis	All axes	DB	○	○	○	○	○	○	○	
25	Absolute position erased	25.1	Servo motor encoder - Absolute position erased	Each axis	Each axis	DB	/	/	○	○	○	/	○	

8. TROUBLESHOOTING

	No.	Name	Detail display	Detail name	Processing system (Note 6)	Stop system	Stop method (Note 4, 5)	Alarm reset			Operation mode			
								Error reset	CPU reset	Power off → on	Standard	Fully closed	Linear	DD
Alarm	27	Initial magnetic pole detection error	27.1	Magnetic pole detection - Abnormal termination	Each axis	Each axis	DB	○	○	○	○	○	○	○
			27.2	Magnetic pole detection - Time out error	Each axis	Each axis	DB	○	○	○	○	○	○	○
			27.3	Magnetic pole detection - Limit switch error	Each axis	Each axis	DB	○	○	○	○	○	○	○
			27.4	Magnetic pole detection - Estimated error	Each axis	Each axis	DB	○	○	○	○	○	○	○
			27.5	Magnetic pole detection - Position deviation error	Each axis	Each axis	DB	○	○	○	○	○	○	○
			27.6	Magnetic pole detection - Speed deviation error	Each axis	Each axis	DB	○	○	○	○	○	○	○
			27.7	Magnetic pole detection - Current error	Each axis	Each axis	DB	○	○	○	○	○	○	○
	28	Linear encoder error 2	28.1	Linear encoder - Environment error	Each axis	Each axis	EDB	○	○	○	○	○	○	○
	2A	Linear encoder error 1	2A.1	Linear encoder error 1-1	Each axis	Each axis	EDB	○	○	○	○	○	○	○
			2A.2	Linear encoder error 1-2	Each axis	Each axis	EDB	○	○	○	○	○	○	○
			2A.3	Linear encoder error 1-3	Each axis	Each axis	EDB	○	○	○	○	○	○	○
			2A.4	Linear encoder error 1-4	Each axis	Each axis	EDB	○	○	○	○	○	○	○
			2A.5	Linear encoder error 1-5	Each axis	Each axis	EDB	○	○	○	○	○	○	○
			2A.6	Linear encoder error 1-6	Each axis	Each axis	EDB	○	○	○	○	○	○	○
			2A.7	Linear encoder error 1-7	Each axis	Each axis	EDB	○	○	○	○	○	○	○
			2A.8	Linear encoder error 1-8	Each axis	Each axis	EDB	○	○	○	○	○	○	○
	2B	Encoder counter error	2B.1	Encoder counter error 1	Each axis	Each axis	EDB	○	○	○	○	○	○	○
			2B.2	Encoder counter error 2	Each axis	Each axis	EDB	○	○	○	○	○	○	○
	30	Regenerative error (Note 1)	30.1	Regeneration heat error	Common	All axes	DB	○ (Note 1)	○ (Note 1)	○ (Note 1)	○	○	○	○
			30.2	Regeneration signal error	Common	All axes	DB	○ (Note 1)	○ (Note 1)	○ (Note 1)	○	○	○	○
			30.3	Regeneration feedback signal error	Common	All axes	DB	○ (Note 1)	○ (Note 1)	○ (Note 1)	○	○	○	○
	31	Overspeed	31.1	Abnormal motor speed	Each axis	Each axis	SD	○	○	○	○	○	○	○
	32	Overcurrent	32.1	Overcurrent detected at hardware detection circuit (during operation)	Each axis	All axes	DB	○	○	○	○	○	○	○
			32.2	Overcurrent detected at software detection function (during operation)	Each axis	All axes	DB	○	○	○	○	○	○	○
			32.3	Overcurrent detected at hardware detection circuit (during a stop)	Each axis	All axes	DB	○	○	○	○	○	○	○
			32.4	Overcurrent detected at software detection function (during a stop)	Each axis	All axes	DB	○	○	○	○	○	○	○
	33	Overvoltage	33.1	Main circuit voltage error	Common	All axes	DB	○	○	○	○	○	○	○
	34	SSCNET receive error 1	34.1	SSCNET receive data error	Common	All axes	SD	○	○ (Note 2)	○	○	○	○	○
			34.2	SSCNET connector connection error	Common	All axes	SD	○	○	○	○	○	○	○
			34.3	SSCNET communication data error	Each axis	Each axis	SD	○	○	○	○	○	○	○
			34.4	Hardware error signal detection	Common	All axes	SD	○	○	○	○	○	○	○

8. TROUBLESHOOTING

	No.	Name	Detail display	Detail name	Processing system (Note 6)	Stop system	Stop method (Note 4, 5)	Alarm reset			Operation mode			
								Error reset	CPU reset	Power off → on	Standard	Fully closed	Linear	DD
Alarm	35	Command frequency error	35.1	Command frequency error	Each axis	Each axis	SD	○	○	○	○	○	○	○
	36	SSCNET receive error 2	36.1	Continuous communication data error	Each axis	Each axis	SD	○	○	○	○	○	○	○
	37	Parameter error	37.1	Parameter setting range error	Each axis	Each axis	DB	△	○	○	○	○	○	○
			37.2	Parameter combination error	Each axis	Each axis	DB	△	○	○	○	○	○	○
	3A	Inrush current suppression circuit error	3A.1	Inrush current suppression circuit error	Common	All axes	DB	△	△	○	○	○	○	○
	3E	Operation mode error	3E.1	Operation mode error	Common	All axes	DB	△	△	○	○	○	○	○
	42	Servo control error	42.1	Servo control error by position deviation	Each axis	Each axis	DB	○ (Note 3)	○ (Note 3)	○	△	△	○	○
			42.2	Servo control error by speed deviation	Each axis	Each axis	DB	○ (Note 3)	○ (Note 3)	○	△	△	○	○
			42.3	Servo control error by torque/thrust deviation	Each axis	Each axis	DB	○ (Note 3)	○ (Note 3)	○	△	△	○	○
			42.8	Fully closed loop control error by position deviation	Each axis	Each axis	DB	○ (Note 3)	○ (Note 3)	○	△	○	△	△
			42.9	Fully closed loop control error by speed deviation	Each axis	Each axis	DB	○ (Note 3)	○ (Note 3)	○	△	○	△	△
			42.A	Fully closed loop control error by position deviation (during command stop)	Each axis	Each axis	DB	○ (Note 3)	○ (Note 3)	○	△	○	△	△
	45	Main circuit device overheat (Note 1)	45.1	Main circuit device overheat error	Common	All axes	SD	○ (Note 1)	○ (Note 1)	○ (Note 1)	○	○	○	○
	46	Servo motor overheat (Note 1)	46.1	Abnormal temperature of servo motor 1	Each axis	Each axis	SD	○ (Note 1)	○ (Note 1)	○ (Note 1)	○	○	△	○
			46.2	Abnormal temperature of servo motor 2	Each axis	Each axis	SD	○ (Note 1)	○ (Note 1)	○ (Note 1)	△	○	○	○
			46.3	Thermistor disconnected	Each axis	Each axis	SD	○ (Note 1)	○ (Note 1)	○ (Note 1)	○	○	○	○
			46.5	Abnormal temperature of servo motor 3	Each axis	Each axis	DB	○ (Note 1)	○ (Note 1)	○ (Note 1)	○	○	△	△
			46.6	Abnormal temperature of servo motor 4	Each axis	Each axis	DB	○ (Note 1)	○ (Note 1)	○ (Note 1)	○	○	△	△
	47	Cooling fan error	47.1	Cooling fan stop error	Common	All axes	SD	△	△	○	○	○	○	○
			47.2	Cooling fan speed reduction error	Common	All axes	SD	△	△	○	○	○	○	○
	50	Overload 1 (Note 1)	50.1	Thermal overload error 1 during operation	Each axis	Each axis	SD	○ (Note 1)	○ (Note 1)	○ (Note 1)	○	○	○	○
			50.2	Thermal overload error 2 during operation	Each axis	Each axis	SD	○ (Note 1)	○ (Note 1)	○ (Note 1)	○	○	○	○
			50.3	Thermal overload error 4 during operation	Each axis	Each axis	SD	○ (Note 1)	○ (Note 1)	○ (Note 1)	○	○	○	○
			50.4	Thermal overload error 1 during a stop	Each axis	Each axis	SD	○ (Note 1)	○ (Note 1)	○ (Note 1)	○	○	○	○
			50.5	Thermal overload error 2 during a stop	Each axis	Each axis	SD	○ (Note 1)	○ (Note 1)	○ (Note 1)	○	○	○	○
			50.6	Thermal overload error 4 during a stop	Each axis	Each axis	SD	○ (Note 1)	○ (Note 1)	○ (Note 1)	○	○	○	○
	51	Overload 2 (Note 1)	51.1	Thermal overload error 3 during operation	Each axis	Each axis	DB	○ (Note 1)	○ (Note 1)	○ (Note 1)	○	○	○	○
			51.2	Thermal overload error 3 during a stop	Each axis	Each axis	DB	○ (Note 1)	○ (Note 1)	○ (Note 1)	○	○	○	○

8. TROUBLESHOOTING

	No.	Name	Detail display	Detail name	Processing system (Note 6)	Stop system	Stop method (Note 4, 5)	Alarm reset			Operation mode			
								Error reset	CPU reset	Power off → on	Standard	Fully closed	Linear	DD
Alarm	52	Error excessive	52.1	Excess droop pulse 1	Each axis	Each axis	SD	○	○	○	○	○	○	○
			52.3	Excess droop pulse 2	Each axis	Each axis	SD	○	○	○	○	○	○	○
			52.4	Error excessive during 0 torque limit	Each axis	Each axis	SD	○	○	○	○	○	○	○
			52.5	Excess droop pulse 3	Each axis	Each axis	DB	○	○	○	○	○	○	○
	54	Oscillation detection	54.1	Oscillation detection error	Each axis	Each axis	DB	○	○	○	○	○	○	○
	56	Forced stop error	56.2	Over speed during forced stop	Each axis	Each axis	DB	○	○	○	○	○	○	○
			56.3	Estimated distance over during forced stop	Each axis	Each axis	DB	○	○	○	○	○	○	○
	63	STO timing error	63.1	STO1 off	Common	All axes	DB	○	○	○	○	○	○	○
			63.2	STO2 off	Common	All axes	DB	○	○	○	○	○	○	○
	70	Load-side encoder initial communication error 1	70.1	Load-side encoder initial communication - Receive data error 1	Each axis	Each axis	DB	△	△	○	△	○	△	△
			70.2	Load-side encoder initial communication - Receive data error 2	Each axis	Each axis	DB	△	△	○	△	○	△	△
			70.3	Load-side encoder initial communication - Receive data error 3	Each axis	Each axis	DB	△	△	○	△	○	△	△
			70.5	Load-side encoder initial communication - Transmission data error 1	Each axis	Each axis	DB	△	△	○	△	○	△	△
			70.6	Load-side encoder initial communication - Transmission data error 2	Each axis	Each axis	DB	△	△	○	△	○	△	△
			70.7	Load-side encoder initial communication - Transmission data error 3	Each axis	Each axis	DB	△	△	○	△	○	△	△
			70.A	Load-side encoder initial communication - Process error 1	Each axis	Each axis	DB	△	△	○	△	○	△	△
			70.B	Load-side encoder initial communication - Process error 2	Each axis	Each axis	DB	△	△	○	△	○	△	△
			70.C	Load-side encoder initial communication - Process error 3	Each axis	Each axis	DB	△	△	○	△	○	△	△
			70.D	Load-side encoder initial communication - Process error 4	Each axis	Each axis	DB	△	△	○	△	○	△	△
			70.E	Load-side encoder initial communication - Process error 5	Each axis	Each axis	DB	△	△	○	△	○	△	△
			70.F	Load-side encoder initial communication - Process error 6	Each axis	Each axis	DB	△	△	○	△	○	△	△
	71	Load-side encoder normal communication error 1	71.1	Load-side encoder communication - Receive data error 1	Each axis	Each axis	DB	△	△	○	△	○	△	△
			71.2	Load-side encoder communication - Receive data error 2	Each axis	Each axis	DB	△	△	○	△	○	△	△
71.3			Load-side encoder communication - Receive data error 3	Each axis	Each axis	DB	△	△	○	△	○	△	△	
71.5			Load-side encoder communication - Transmission data error 1	Each axis	Each axis	DB	△	△	○	△	○	△	△	
71.6			Load-side encoder communication - Transmission data error 2	Each axis	Each axis	DB	△	△	○	△	○	△	△	
71.7			Load-side encoder communication - Transmission data error 3	Each axis	Each axis	DB	△	△	○	△	○	△	△	
71.9			Load-side encoder communication - Receive data error 4	Each axis	Each axis	DB	△	△	○	△	○	△	△	
71.A			Load-side encoder communication - Receive data error 5	Each axis	Each axis	DB	△	△	○	△	○	△	△	

8. TROUBLESHOOTING

	No.	Name	Detail display	Detail name	Processing system (Note 6)	Stop system	Stop method (Note 4, 5)	Alarm reset			Operation mode			
								Error reset	CPU reset	Power off → on	Standard	Fully closed	Linear	DD
Alarm	72	Load-side encoder normal communication error 2	72.1	Load-side encoder data error 1	Each axis	Each axis	DB	○	○	○	○	○	○	○
			72.2	Load-side encoder data update error	Each axis	Each axis	DB	○	○	○	○	○	○	○
			72.3	Load-side encoder data waveform error	Each axis	Each axis	DB	○	○	○	○	○	○	○
			72.4	Load-side encoder non-signal error	Each axis	Each axis	DB	○	○	○	○	○	○	○
			72.5	Load-side encoder hardware error 1	Each axis	Each axis	DB	○	○	○	○	○	○	○
			72.6	Load-side encoder hardware error 2	Each axis	Each axis	DB	○	○	○	○	○	○	○
			72.9	Load-side encoder data error 2	Each axis	Each axis	DB	○	○	○	○	○	○	○
	8A	USB communication time-out error	8A.1	USB communication time-out error	Common	All axes	SD	○	○	○	○	○	○	○
	8E	USB communication error	8E.1	USB communication receive error	Common	All axes	SD	○	○	○	○	○	○	○
			8E.2	USB communication checksum error	Common	All axes	SD	○	○	○	○	○	○	○
			8E.3	USB communication character error	Common	All axes	SD	○	○	○	○	○	○	○
			8E.4	USB communication command error	Common	All axes	SD	○	○	○	○	○	○	○
			8E.5	USB communication data number error	Common	All axes	SD	○	○	○	○	○	○	○
	888	Watchdog	88_	Watchdog	Common	All axes	DB	○	○	○	○	○	○	

- Note
1. Leave for about 30 minutes of cooling time after removing the cause of occurrence.
 2. In some controller communication status, the alarm factor may not be removed.
 3. The alarm can be canceled by setting as follows:
When a linear servo motor or a direct drive motor is used: set [Pr. PL04] to "1 _ _ _".
 4. Stop method indicates as follows:
DB: Stops with dynamic brake. (Coasts for the servo amplifier without dynamic brake.)
EDB: Stops with electronic dynamic brake for 600 W or lower capacity servo amplifiers.
Stops with dynamic brake for 700 W or larger capacity servo amplifiers.
SD: Forced stop deceleration
 5. This is applicable when [Pr. PA04] is set to the initial value. The stop system of SD can be changed to DB using [Pr. PA04].
 6. Processing system indicates as follows:
Each axis: an alarm is detected for each axis.
Common: an alarm is detected for the entire servo amplifier.
 7. This alarm will occur only in the J3 compatibility mode.

8. TROUBLESHOOTING

	No.	Name	Detail display	Detail name	Processing system (Note 5)	Stop system	Stop method (Note 2, 3)	Operation mode			
								Standard	Fully closed	Linear	DD
Warnings	91	Servo amplifier overheat warning (Note 1)	91.1	Main circuit device overheat warning	Common			○	○	○	○
	92	Battery cable disconnection warning	92.1	Encoder battery cable disconnection warning	Each axis			○			○
			92.3	Battery degradation	Each axis			○			
	95	STO warning	95.1	STO1 off detection	Common	All axes	DB	○	○	○	○
			95.2	STO2 off detection	Common	All axes	DB	○	○	○	○
	96	Home position setting warning	96.1	In-position warning at home positioning	Each axis			○	○	○	○
			96.2	Command input warning at home positioning	Each axis			○	○	○	○
	9F	Battery warning	9F.1	Low battery	Each axis			○	○	○	○
			9F.2	Battery degradation warning	Each axis						○
	E0	Excessive regeneration warning (Note 1)	E0.1	Excessive regeneration warning	Common			○	○	○	○
	E1	Overload warning 1 (Note 1)	E1.1	Thermal overload warning 1 during operation	Each axis			○	○	○	○
			E1.2	Thermal overload warning 2 during operation	Each axis			○	○	○	○
			E1.3	Thermal overload warning 3 during operation	Each axis			○	○	○	○
			E1.4	Thermal overload warning 4 during operation	Each axis			○	○	○	○
			E1.5	Thermal overload warning 1 during a stop	Each axis			○	○	○	○
			E1.6	Thermal overload warning 2 during a stop	Each axis			○	○	○	○
			E1.7	Thermal overload warning 3 during a stop	Each axis			○	○	○	○
			E1.8	Thermal overload warning 4 during a stop	Each axis			○	○	○	○
	E2	Servo motor overheat warning	E2.1	Servo motor temperature warning	Each axis			○	○	○	○
	E3	Absolute position counter warning	E3.2	Absolute position counter warning	Each axis			○	○		○
E3.5			Encoder absolute positioning counter warning	Each axis			○			○	

8. TROUBLESHOOTING

	No.	Name	Detail display	Detailed name	Processing system (Note 5)	Stop system	Stop method (Note 2, 3)	Operation mode			
								Standard	Fully closed	Linear	DD
Warnings	E4	Parameter warning	E4.1	Parameter setting range error warning	Each axis			○	○	○	○
	E6	Servo forced stop warning	E6.1	Forced stop warning	Common	All axes	SD	○	○	○	○
	E7	Controller forced stop warning	E7.1	Controller forced stop warning	Common	All axes	SD	○	○	○	○
	E8	Cooling fan speed reduction warning	E8.1	Decreased cooling fan speed warning	Common			○	○	○	○
			E8.2	Cooling fan stop	Common			○	○	○	○
	E9	Main circuit off warning	E9.1	Servo-on signal on during main circuit off	Common	All axes	DB	○	○	○	○
			E9.2	Bus voltage drop during low speed operation	Common	All axes	DB	○	○	○	○
			E9.3	Ready-on signal on during main circuit off	Common	All axes	DB	○	○	○	○
	EB	The other axis error warning	EB.1	The other axis error warning	Each axis	All axes (Note 4)	DB	○		○	○
	EC	Overload warning 2 (Note 1)	EC.1	Overload warning 2	Each axis			○	○	○	○
	ED	Output watt excess warning	ED.1	Output watt excess warning	Each axis			○	○	○	○
	F0	Tough drive warning	F0.1	Instantaneous power failure tough drive warning	Each axis			○	○	○	○
			F0.3	Vibration tough drive warning	Each axis			○	○	○	○
	F2	Drive recorder - Miswriting warning	F2.1	Drive recorder - Area writing time-out warning	Common			○	○	○	○
F2.2			Drive recorder - Data miswriting warning	Common			○	○	○	○	
F3	Oscillation detection warning	F3.1	Oscillation detection warning	Each axis			○	○	○	○	

Note 1. Leave for about 30 minutes of cooling time after removing the cause of occurrence.

2. Stop method indicates as follows:

DB: Stops with dynamic brake. (Coasts for the servo amplifier without dynamic brake.)

SD: Forced stop deceleration

3. This is applicable when [Pr. PA04] is set to the initial value. The stop system of SD can be changed to DB using [Pr. PA04].

4. Stopping all axes or each axis can be selected using [Pr. PF02].

5. Processing system indicates as follows:

Each axis: an alarm is detected for each axis.

Common: an alarm is detected for the entire servo amplifier.

8. TROUBLESHOOTING

8.2 Troubleshooting at power on

When the servo system does not boot and system error occurs at power on of the servo system controller, improper boot of the servo amplifier might be the cause. Check the display of the servo amplifier, and take actions according to this section.

Display	Description	Cause	Checkpoint	Action
AA	Communication with the servo system controller has disconnected.	The power of the servo system controller was turned off.	Check the power of the servo system controller.	Switch on the power of the servo system controller.
		SSCNET III cable was disconnected.	"AA" is displayed in the corresponding axis and following axes.	Replace the SSCNET III cable of the corresponding axis.
			Check if the connectors (CNIA, CNIB) are unplugged.	Connect correctly.
		The power of the servo amplifier was turned off.	"AA" is displayed in the corresponding axis and following axes.	Check the power of the servo amplifier.
				Replace the servo amplifier of the corresponding axis.
Ab	Initialization communication with the servo system controller has not completed.	All axes are in a state of disabling control axis.	Check if the disabling control axis switches (SW2-2, 2-3, and 2-4) are on.	Turn off the disabling control axis switches (SW2-2, 2-3, and 2-4).
		Axis No. is set incorrectly.	Check that the other servo amplifier is not assigned to the same axis No.	Set it correctly.
		Axis No. does not match with the axis No. set to the servo system controller.	Check the setting and axis No. of the servo system controller.	Set it correctly.
		Information about the servo series has not set in the simple motion module.	Check the value set in Servo series (Pr.100) in the simple motion module.	Set it correctly.
		Communication cycle does not match.	Check the communication cycle at the servo system controller side. When using 8 axes or less: 0.222 ms When using 16 axes or less: 0.444 ms When using 32 axes or less: 0.888 ms	Set it correctly.
		SSCNET III cable was disconnected.	"Ab" is displayed in the corresponding axis and following axes.	Replace the SSCNET III cable of the corresponding axis.
			Check if the connectors (CNIA, CNIB) are unplugged.	Connect correctly.
		The power of the servo amplifier was turned off.	"Ab" is displayed in an axis and the following axes.	Check the power of the servo amplifier.
The servo amplifier is malfunctioning.	"Ab" is displayed in an axis and the following axes.	Replace the servo amplifier of the corresponding axis.		
b##. (Note)	The system has been in the test operation mode.	Test operation mode has been active.	Test operation setting switch (SW2-1) is turned on.	Turn off the test operation setting switch (SW2-1).
off	Operation mode for manufacturer setting is set.	Operation mode for manufacturer setting is enabled.	Check if all of the control axis setting switches (SW2) are on.	Set the control axis setting switches (SW2) correctly.

Note. ## indicates axis No.

9. OUTLINE DRAWINGS

9. OUTLINE DRAWINGS

9.1 Servo amplifier

(1) MR-J4W2-22B/MR-J4W2-44B

[Unit: mm]

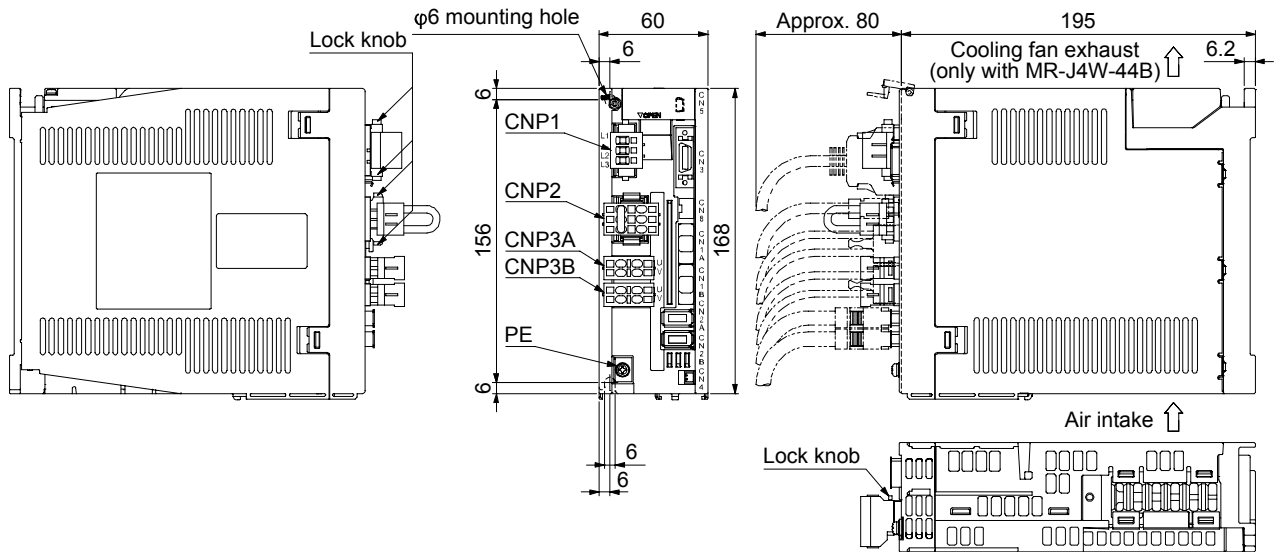

Mass: 1.4 [kg]

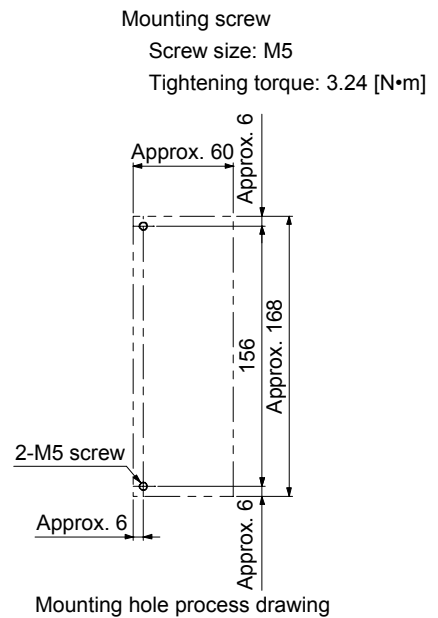
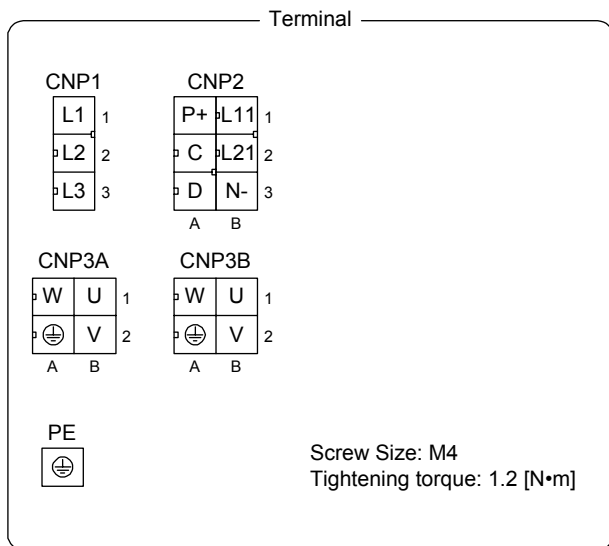

9. OUTLINE DRAWINGS

(2) MR-J4W2-77B/MR-J4W2-1010B

[Unit: mm]

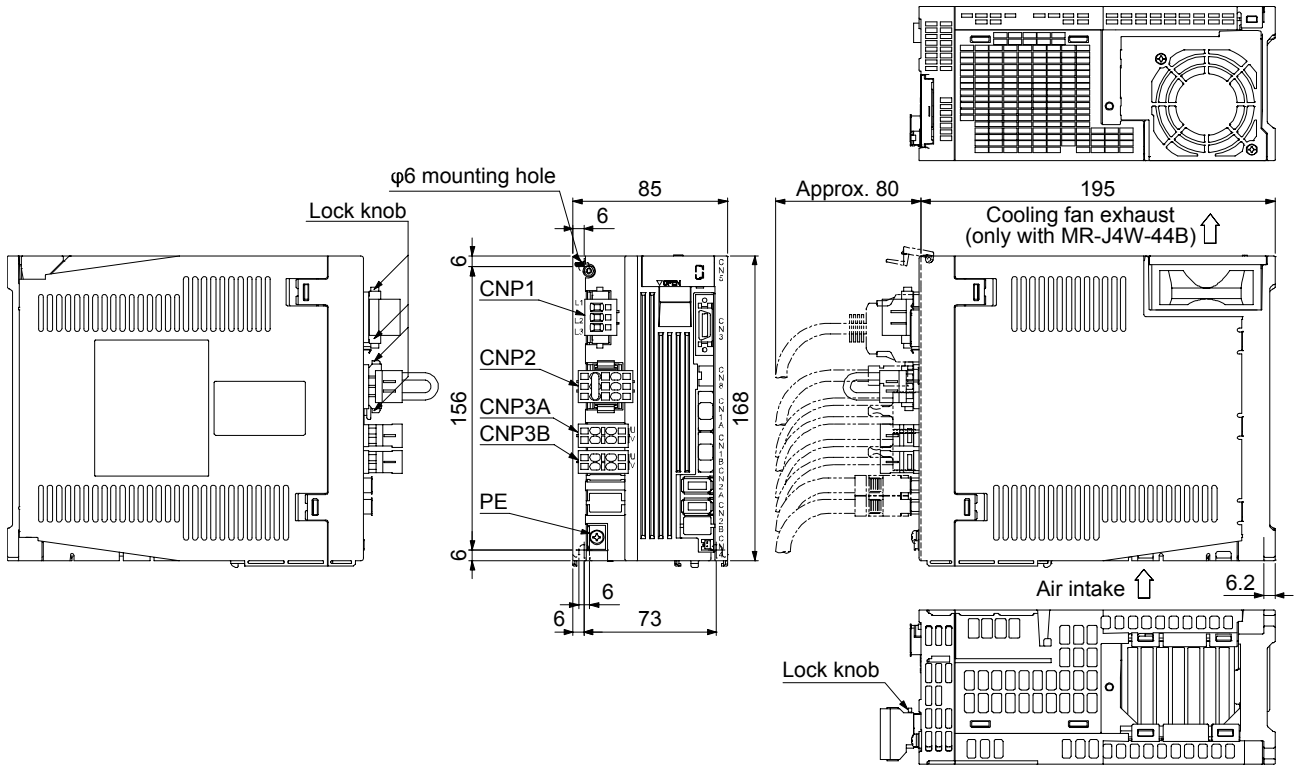

Mass: 2.3 [kg]

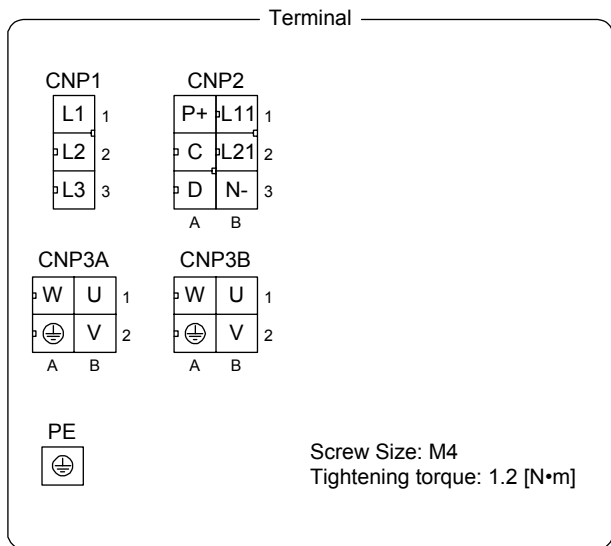

Mounting screw
Screw size: M5
Tightening torque: 3.24 [N•m]

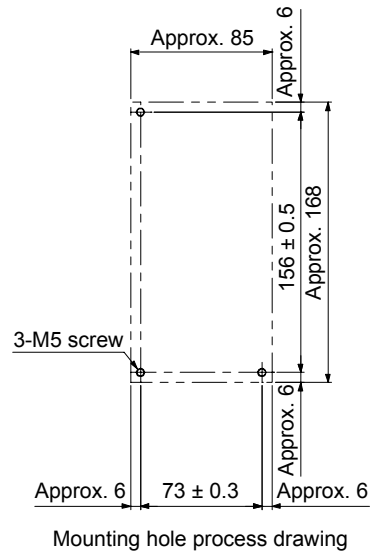

9. OUTLINE DRAWINGS

(3) MR-J4W3-222B/MR-J4W3-444B

[Unit: mm]

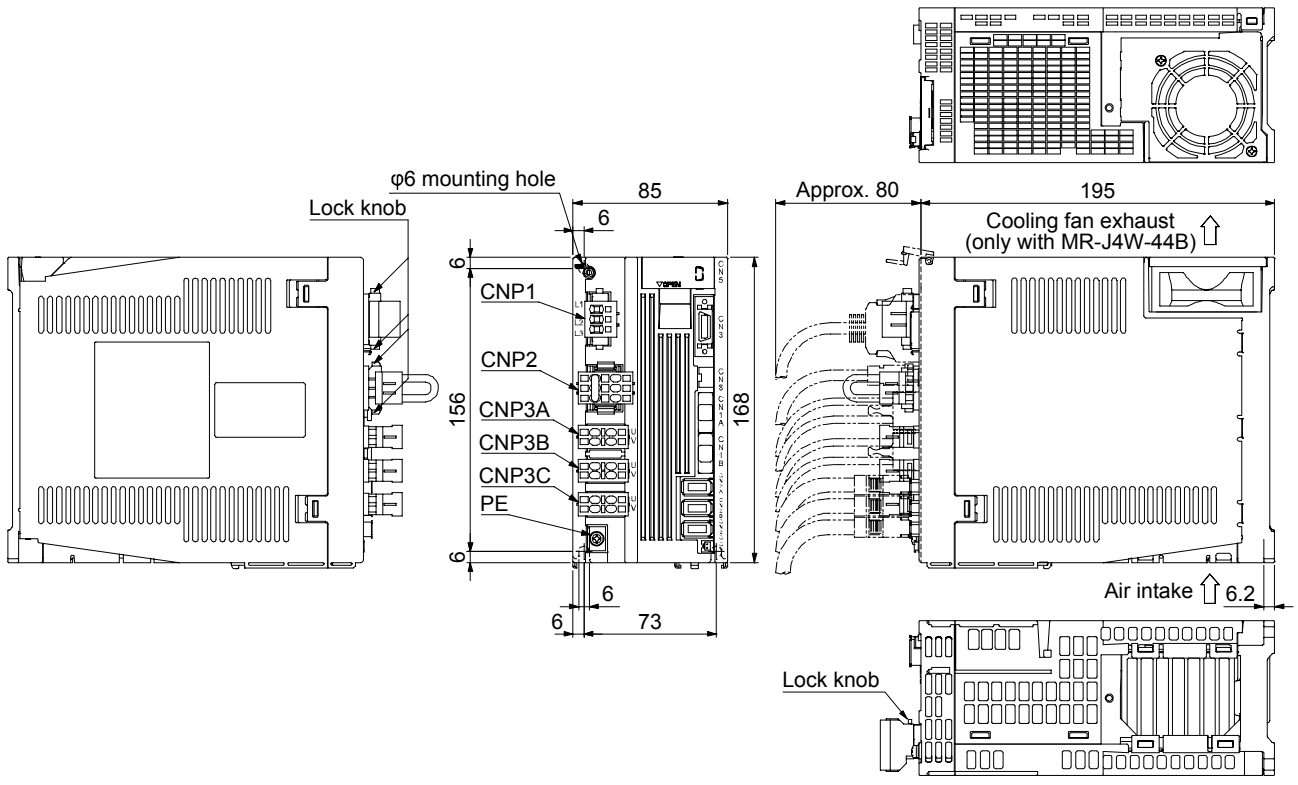

Mass: 2.3 [kg]

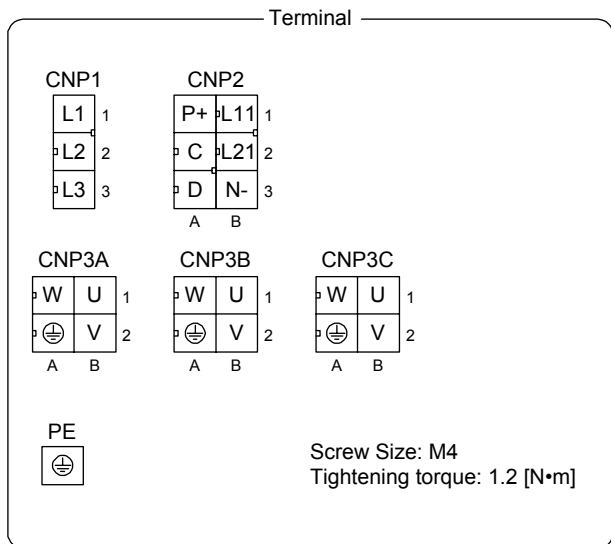

Mounting screw
Screw size: M5
Tightening torque: 3.24 [N•m]

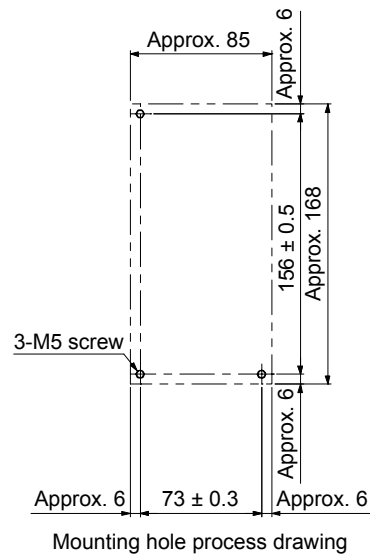

9. OUTLINE DRAWINGS

9.2 Connector

(1) CN1A/CN1B connector

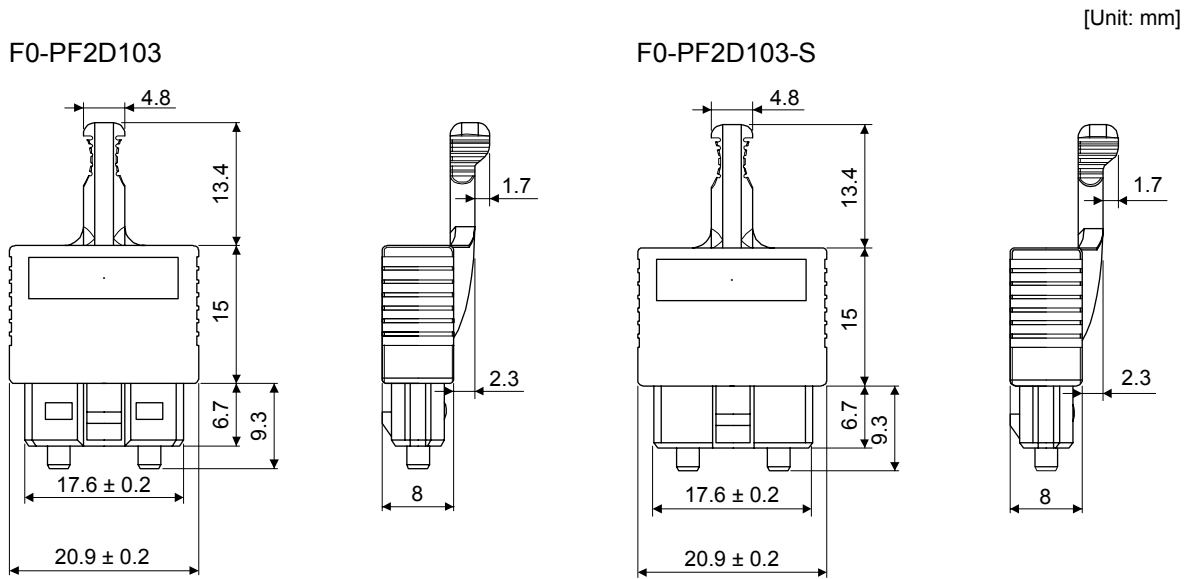

(2) Miniature delta ribbon (MDR) system (3M) (a) One-touch lock type

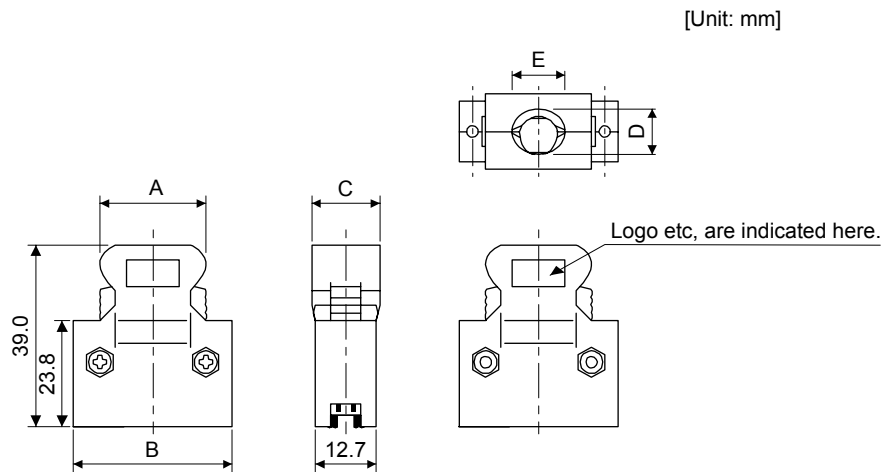

Connector	Shell kit	Each type of dimension				
		A	B	C	D	E
10120-3000PE	10320-52F0-008	22.0	33.3	14.0	10.0	12.0

9. OUTLINE DRAWINGS

- (b) Jack screw M2.6 type
This is not available as option.

[Unit: mm]

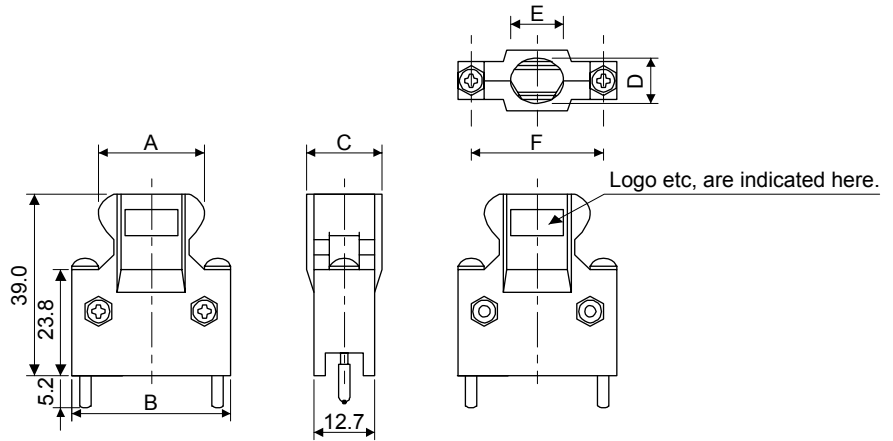

Connector	Shell kit	Each type of dimension					
		A	B	C	D	E	F
10120-3000PE	10320-52F0-008	22.0	33.3	14.0	10.0	12.0	27.4

- (3) SCR connector system (3M)
Receptacle: 36210-0100PL
Shell kit: 36310-3200-008

[Unit: mm]

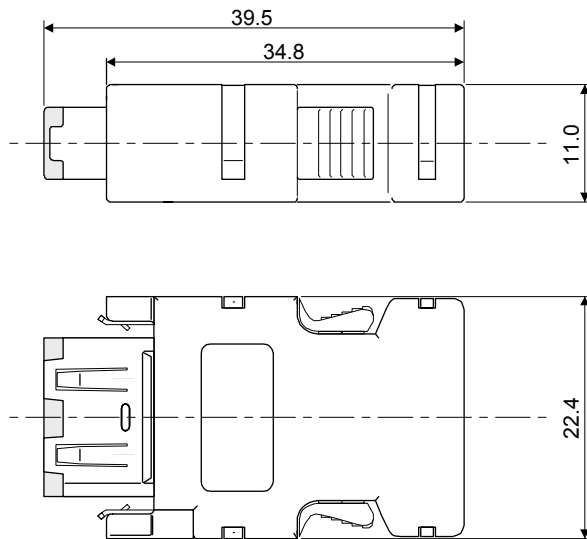

10. CHARACTERISTICS

10. CHARACTERISTICS

POINT
<p>● For the characteristics of the linear servo motor and the direct drive motor, refer to sections 14.4 and 15.4.</p>

10.1 Overload protection characteristics

An electronic thermal is built in the servo amplifier to protect the servo motor, servo amplifier and servo motor power wires from overloads.

[AL. 50 Overload 1] occurs if overload operation performed is above the electronic thermal protection curve shown in fig. 10.1 [AL. 51 Overload 2] occurs if the maximum current is applied continuously for several seconds due to machine collision, etc. Use the equipment on the left-hand side area of the continuous or broken line in the graph.

When unbalanced torque is generated, such as in a vertical lift machine, it is recommended that the unbalanced torque of the machine be kept at 70% or less of the motor's rated torque.

This servo amplifier has solid-state servo motor overload protection for each axis. (The servo motor overload current (full load current) is set on the basis of 120% rated current of the servo amplifier.)

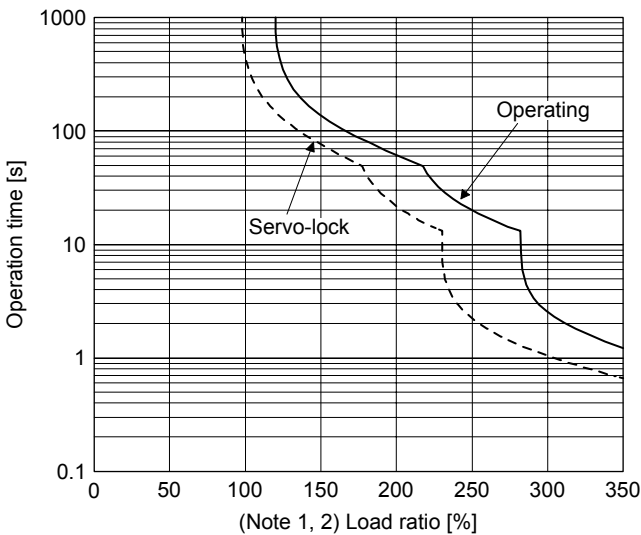

HG-KR053, HG-KR13
HG-MR053, HG-MR13

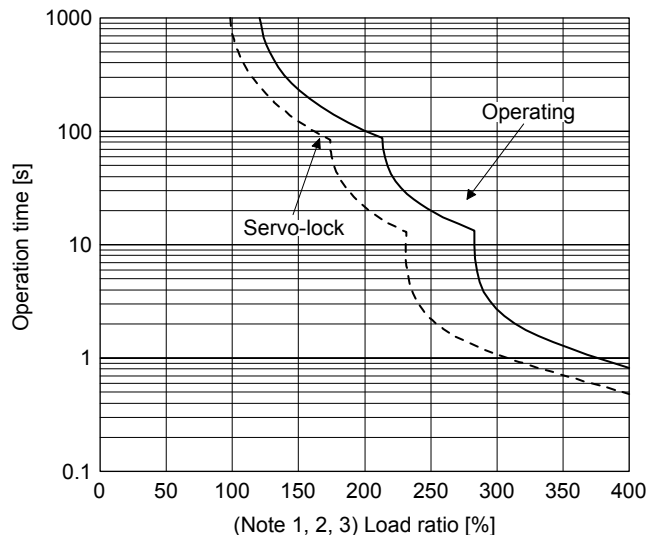

HG-KR23, HG-KR43, HG-KR73
HG-MR23, HG-MR43, HG-MR73
HG-SR51, HG-SR81, HG-SR52, HG-SR102
HG-UR72
HG-JR53, HG-JR73, HG-JR103

- Note 1. If operation that generates torque more than 100% of the rating is performed with an abnormally high frequency in a servo motor stop status (servo-lock status) or in a 30 r/min or less low-speed operation status, the servo amplifier may malfunction regardless of the electronic thermal protection.
- Note 2. The load ratio ranging from 300% to 350% applies to the HG-KR series servo motor.
- Note 3. The load ratio ranging from 350% to 400% applies to the HG-JR53 servo motor.

Fig. 10.1 Electronic thermal protection characteristics

10. CHARACTERISTICS

10.2 Power supply capacity and generated loss

Calculate the generated loss and the power supply capacity of the servo amplifier under rated load from (1) and (2) in this section. The calculated value will vary depending on the number of connected servo motors and the capacities of the servo motors. For thermal design of an enclosed type cabinet, use the values calculated in consideration for the worst operating conditions. The actual amount of generated heat will be intermediate between values at rated torque and servo-off according to the duty used during operation. When the servo motor is run at less than the rated speed, the power supply capacity will be smaller than the calculated value, but the servo amplifier's generated heat will not change.

(1) Calculation method of power supply capacity

Calculate the power supply capacity for one servo amplifier from tables 10.1 and 10.2.

Table 10.1 Power supply capacity for one servo amplifier at rated output

Servo amplifier	(Note) Power supply capacity [kVA]
MR-J4W2-22B	Total power supply capacity of connected servo motors (A) in table 10.2)
MR-J4W2-44B	
MR-J4W2-77B	
MR-J4W2-1010B	
MR-J4W3-222B	
MR-J4W3-444B	

Note. Note that the power supply capacity will vary according to the power supply impedance. This value is applicable when the power factor improving reactor is not used.

Table 10.2 Servo amplifier power supply capacity for one servo motor

Servo motor	Power supply capacity [kVA] (A)
HG-KR053	0.3
HG-KR13	0.3
HG-KR23	0.5
HG-KR43	0.9
HG-KR73	1.3
HG-MR053	0.3
HG-MR13	0.3
HG-MR23	0.5
HG-MR43	0.9
HG-MR73	1.3
HG-SR51	1.0
HG-SR81	1.5
HG-SR52	1.0
HG-SR102	1.7
HG-UR72	1.3
HG-JR53	1.0
HG-JR73	1.3
HG-JR103	1.7

Calculate the power supply capacity with equation 10.1 below.

$$\text{Power supply capacity [kVA]} = \text{Sum of power supply capacity (A) of the connected servo motors} \quad \cdot \cdot \quad (10.1)$$

For example, when a HG-KR43, HG-KR23, and HG-KR053 are connected to an MR-J4W3-444B servo amplifier, according to table 10.1, the power supply capacity of each servo motor is as follows: HG-KR43 = 0.9 [kVA], HG-KR23 = 0.5 [kVA], HG-KR053 = 0.3 [kVA]. Calculate the values with equation 10.1.

$$\text{Power supply capacity [kVA]} = 0.9 + 0.5 + 0.3 = 1.7$$

Under the above conditions, the power supply capacity of the servo amplifier is 1.7 [kVA].

10. CHARACTERISTICS

(2) Calculation method of the amount of heat generated by the servo amplifier

Calculate the amount of heat generated by one servo amplifier from tables 10.3 and 10.4.

Table 10.3 Amount of heat generated by one servo amplifier at rated output

Servo amplifier	(Note) Servo amplifier-generated heat [W]	
	At rated output	With servo-off (C)
MR-J4W2-22B	Sum of the total amount of heat generated by the servo amplifier for each servo motor ((B) in table 10.4) and the amount of heat generated by the servo amplifier with servo-off (C)	20
MR-J4W2-44B		20
MR-J4W2-77B		20
MR-J4W2-1010B		20
MR-J4W3-222B		25
MR-J4W3-444B		25

Note. Heat generated during regeneration is not included in the servo amplifier-generated heat. To calculate heat generated by the regenerative option, refer to section 11.2.

Table 10.4 Amount of heat generated by one servo amplifier for one servo motor

Servo motor	Servo amplifier-generated heat [W] (B)
HG-KR053	10
HG-KR13	10
HG-KR23	10
HG-KR43	20
HG-KR73	35
HG-MR053	10
HG-MR13	10
HG-MR23	10
HG-MR43	20
HG-MR73	35
HG-SR51	25
HG-SR81	35
HG-SR52	25
HG-SR102	35
HG-UR72	35
HG-JR53	25
HG-JR73	35
HG-JR103	35

Calculate the amount of heat generated by the servo amplifier with equation 10.2 below.

Servo amplifier-generated heat at rated output [W]

= Sum of servo amplifier-generated heat (B) + Servo amplifier-generated heat with servo-off (C) ... (10.2)

Under the conditions in (1) in this section, according to table 10.3, the amount of heat generated by the servo amplifier for each servo motor is as follows: HG-KR43 = 20 [W], HG-KR23 = 10 [W], HG-KR053 = 10 [W]. According to table 10.4, the amount of heat generated by the servo amplifier with servo-off is 25 [W]. Calculate the values with equation 10.2.

Servo amplifier-generated heat at rated output [W] = (20 + 10 + 10) + 25 = 65

Under the above conditions, the amount of heat generated by the servo amplifier is 65 [W].

10. CHARACTERISTICS

(3) Heat dissipation area for an enclosed type cabinet

The enclosed type cabinet (hereafter called the cabinet) which will contain the servo amplifier should be designed to ensure that its temperature rise is within +10 °C at the ambient temperature of 40 °C. (With an approximately 5 °C safety margin, the system should operate within a maximum 55 °C limit.) The necessary cabinet heat dissipation area can be calculated by equation 10.3.

$$A = \frac{P}{K \cdot \Delta T} \dots\dots\dots (10.3)$$

A: Heat dissipation area [m²]

P: Loss generated in the cabinet [W]

ΔT: Difference between internal and ambient temperatures [°C]

K: Heat dissipation coefficient [5 to 6]

When calculating the heat dissipation area with equation 10.3, assume that P is the sum of all losses generated in the cabinet. Refer to table 10.3 for heat generated by the servo amplifier. "A" indicates the effective area for heat dissipation, but if the cabinet is directly installed on an insulated wall, that extra amount must be added to the cabinet's surface area. The required heat dissipation area will vary with the conditions in the cabinet. If convection in the cabinet is poor and heat builds up, effective heat dissipation will not be possible. Therefore, arrangement of the equipment in the cabinet and the use of a cooling fan should be considered. Table 10.3 lists the cabinet dissipation area for each servo amplifier (guideline) when the servo amplifier is operated at the ambient temperature of 40 °C under rated load.

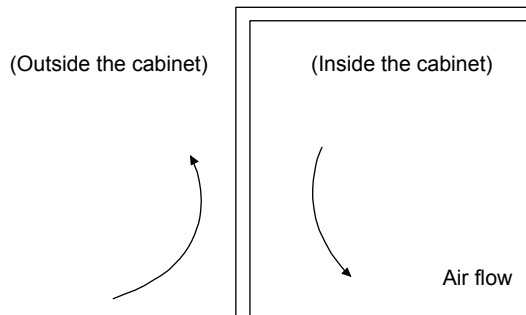

Fig. 10.2 Temperature distribution in an enclosed type cabinet

When air flows along the outer wall of the cabinet, effective heat exchange will be possible, because the temperature slope inside and outside the cabinet will be steeper.

10. CHARACTERISTICS

10.3 Dynamic brake characteristics

POINT	
●	Do not use dynamic brake to stop in a normal operation as it is the function to stop in emergency.
●	For a machine operating at the recommended load to motor inertia ratio or less, the estimated number of usage times of the dynamic brake is 1000 times while the machine decelerates from the rated speed to a stop once in 10 minutes.
●	Be sure to enable EM1 (Forced stop 1) after servo motor stops when using EM1 (Forced stop 1) frequently in other than emergency.
●	Servo motors for MR-J4 may have the different coasting distance from that of the previous model.
●	The electronic dynamic brake operates in the initial state for the HG series servo motors of 600 [W] or smaller capacity. The time constant "τ" for the electronic dynamic brake will be shorter than that of normal dynamic brake. Therefore, coasting distance will be longer than that of normal dynamic brake. For how to set the electronic dynamic brake, refer to [Pr. PF06] and [Pr. PF12].

10. CHARACTERISTICS

10.3.1 Dynamic brake operation

(1) Calculation of coasting distance

Fig. 10.3 shows the pattern in which the servo motor comes to a stop when the dynamic brake is operated. Use equation 10.4 to calculate an approximate coasting distance to a stop. The dynamic brake time constant τ varies with the servo motor and machine operation speeds. (Refer to (2) of this section.)

A working part generally has a friction force. Therefore, actual coasting distance will be shorter than a maximum coasting distance calculated with the following equation.

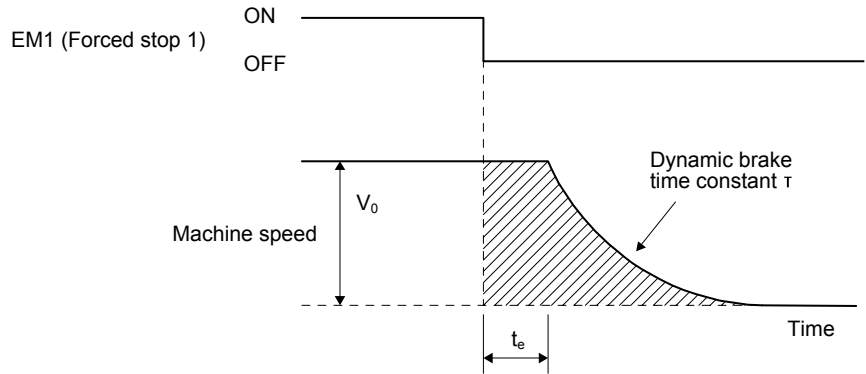

Fig. 10.3 Dynamic brake operation diagram

$$L_{\max} = \frac{V_0}{60} \cdot \left\{ t_e + \tau \left(1 + \frac{J_L}{J_M} \right) \right\} \dots \dots \dots (10.4)$$

- L_{\max} : Maximum coasting distance [mm]
- V_0 : Machine's fast feed speed [mm/min]
- J_M : Moment of inertia of the servo motor [$\times 10^{-4}$ kg·m²]
- J_L : Load moment of inertia converted into equivalent value on servo motor shaft [$\times 10^{-4}$ kg·m²]
- τ : Dynamic brake time constant [s]
- t_e : Delay time of control section [s]

There is internal relay delay time of about 10 ms.

10. CHARACTERISTICS

(2) Dynamic brake time constant

The following shows necessary dynamic brake time constant τ for equation 10.4.

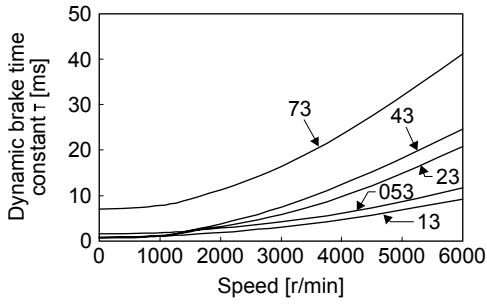

HG-MR series

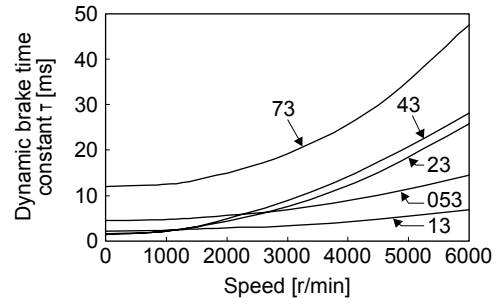

HG-KR series

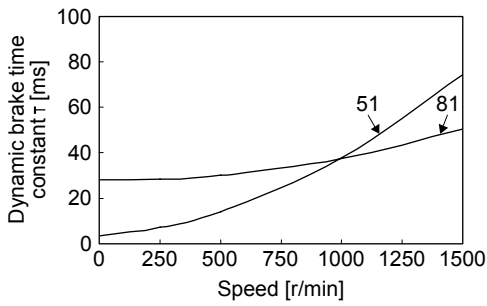

HG-SR 1000 r/min series

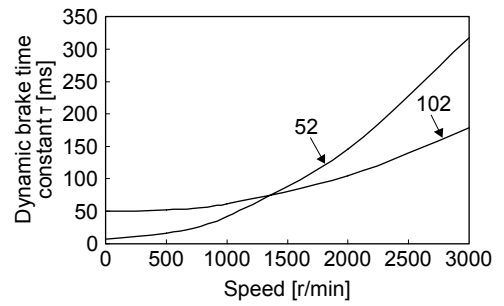

HG-SR 2000 r/min series

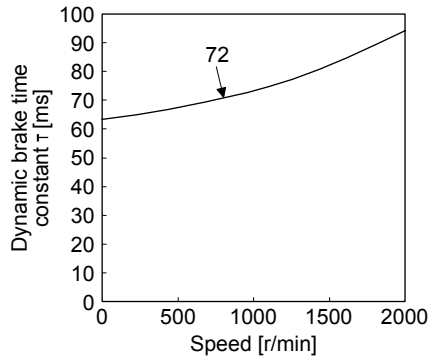

HG-UR series

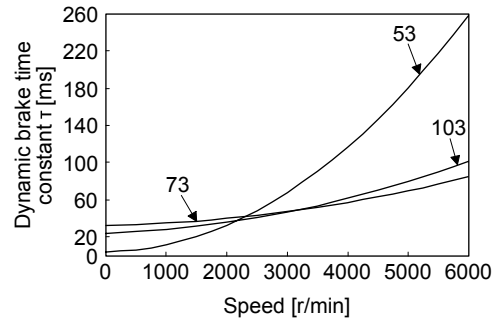

HG-JR3000 r/min series

10. CHARACTERISTICS

10.3.2 Permissible load to motor inertia when the dynamic brake is used

Use the dynamic brake under the load to motor inertia ratio indicated in the following table. If the load inertia moment is higher than this value, the dynamic brake may burn. If there is a possibility that the load inertia moment may exceed the value, contact your local sales office.

The values of the permissible load to motor inertia ratio in the table are the values at the maximum rotation speed of the servo motor.

Servo motor	Permissible load to motor inertia ratio [multiplier]
HG-KR053	30
HG-KR13	
HG-KR23	
HG-KR43	
HG-KR73	
HG-MR053	35
HG-MR13	32
HG-MR23	
HG-MR43	
HG-MR73	

Servo motor	Permissible load to motor inertia ratio [multiplier]
HG-SR51	30
HG-SR81	
HG-SR52	
HG-SR102	
HG-UR72	
HG-JR53	
HG-JR73	
HG-JR103	

10. CHARACTERISTICS

10.4 Cable bending life

The bending life of the cables is shown below. This graph calculated values. Since they are not guaranteed values, provide a little allowance for these values.

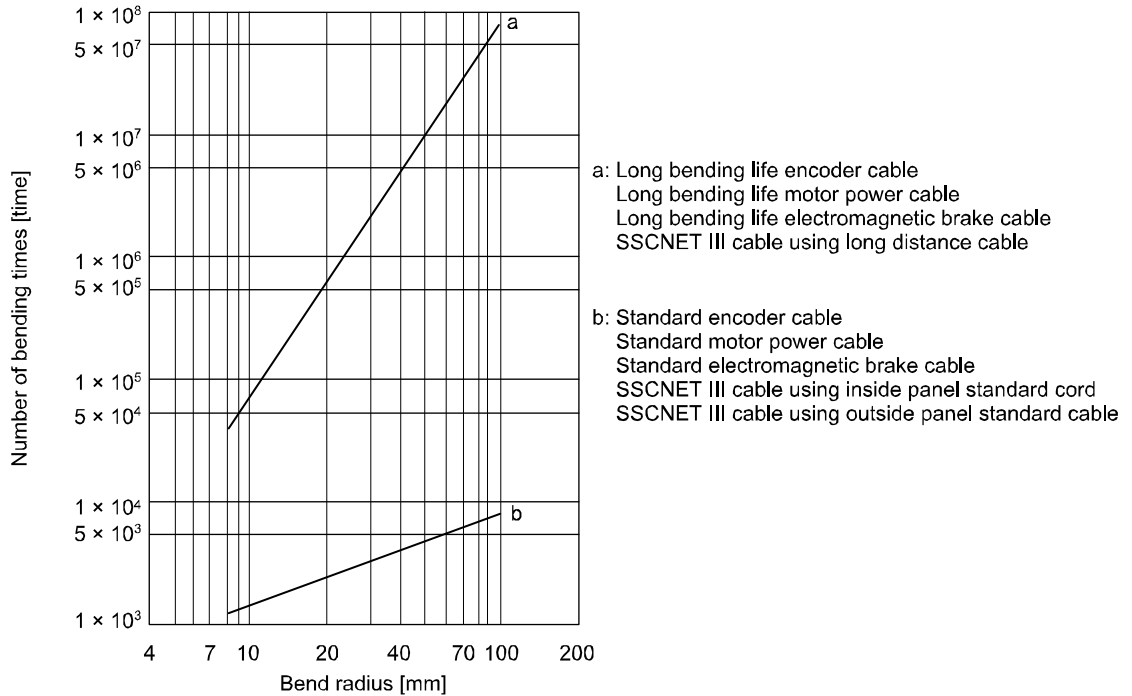

10.5 Inrush currents at power-on of main circuit and control circuit

The following table indicates the inrush currents (reference data) that will flow when 240 V AC is applied at the power supply capacity of 2500 kVA and the wiring length of 1 m. Even when you use a 1-phase 200 V AC power supply with MR-J4W2-22B to MR-J4W2-77B, MR-J4W3-222B, and MR-J4W3-444B, the inrush currents of the main circuit power supply is the same.

MR-J4 2-axis servo amplifier	MR-J4 3-axis servo amplifier	Inrush currents (A _{0-P})	
		Main circuit power supply (L1, L2 and L3)	Control circuit power supply (L11 and L21)
MR-J4W2-22B	MR-J4W3-222B	113 A	24 A (attenuated to approx. 2 A in 20 ms)
MR-J4W2-44B	MR-J4W3-444B	(attenuated to approx. 6 A in 20 ms)	
MR-J4W2-77B		113 A	
MR-J4W2-1010B		(attenuated to approx. 11A in 20 ms)	

Since large inrush currents flow in the power supplies, always use molded-case circuit breakers and magnetic contactors. (Refer to section 11.6.)

When circuit protectors are used, it is recommended that the inertia delay type, which is not tripped by an inrush current, be used.

11. OPTIONS AND AUXILIARY EQUIPMENT

11. OPTIONS AND AUXILIARY EQUIPMENT

	WARNING	● Before connecting any option or peripheral equipment, turn off the power and wait for 15 minutes or more until the charge lamp turns off. Then, confirm that the voltage between P+ and N- is safe with a voltage tester and others. Otherwise, an electric shock may occur. In addition, when confirming whether the charge lamp is off or not, always confirm it from the front of the servo amplifier.
---	----------------	---

	CAUTION	● Use the specified auxiliary equipment and options to prevent a malfunction or a fire.
---	----------------	---

POINT	● We recommend using HIV wires to wire the servo amplifiers, options, and peripheral equipment. Therefore, the recommended wire sizes may differ from those used for the previous servo amplifiers.
--------------	---

11.1 Cable/connector sets

POINT	● The IP rating indicated for cables and connectors is their protection against ingress of dust and raindrops when they are connected to a servo amplifier or servo motor. If the IP rating of the cable, connector, servo amplifier and servo motor vary, the overall IP rating depends on the lowest IP rating of all components.
--------------	---

Purchase the cable and connector options indicated in this section.

11. OPTIONS AND AUXILIARY EQUIPMENT

11.1.1 Combinations of cable/connector sets

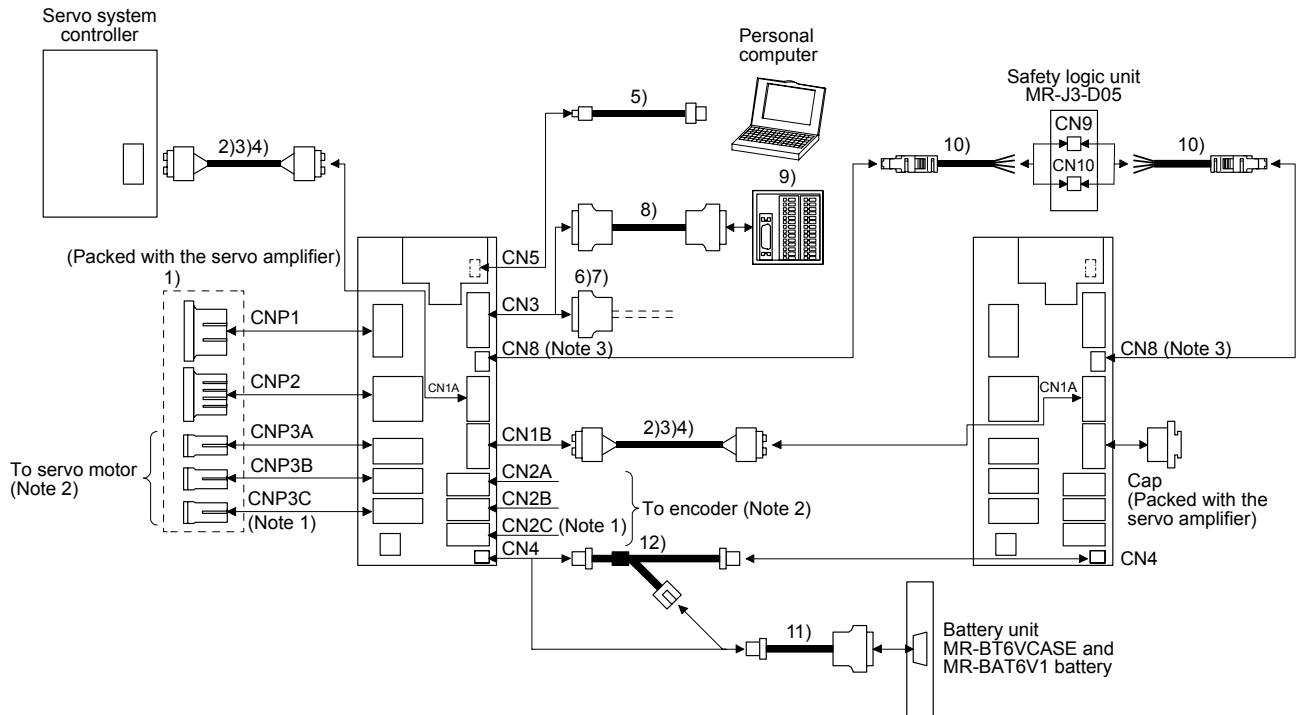







Note 1. CNP3 and CN2C are available only on MR-J4 3-axis servo amplifier.

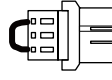
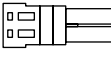
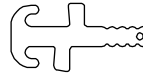



Note 2. Refer to each servo amplifier instruction manual for options for connecting the servo amplifier and the servo motor.

Note 3. When not using the STO function, attach a short-circuit connector (13) supplied with a servo amplifier.

11. OPTIONS AND AUXILIARY EQUIPMENT

No.	Product	Model	Description		Application
1)	Servo amplifier power connector set		 CNP1 connector Quantity: 1 Model: 03JFAT-SAXGFK-43 (JST) Applicable wire size: AWG 16 to 14 Insulator OD: to 4.2 mm	 CNP2 connector Quantity: 1 Model: 06JFAT-SAXYGG-F-KK (JST) Applicable wire size: AWG 16 to 14 Insulator OD: to 3.8 mm	Supplied with servo amplifier
			 CNP3A/CNP3B/CNP3C connector Quantity: 2 (MR-J4W2) 3 (MR-J4W3) Model: 04JFAT-SAGG-G-KK (JST) Applicable wire size: AWG 18 to 14 Insulator OD: to 3.8 mm	 Open tool Quantity: 1 Model: J-FAT-OT-EXL (JST)	
2)	SSCNET III cable	MR-J3BUS_M Cable length: 0.15 m to 3 m (Refer to section 11.1.2.)	Connector: PF-2D103 (JAE)	Connector: PF-2D103 (JAE)	Standard cord inside panel
3)	SSCNET III cable	MR-J3BUS_M-A Cable length: 5 m to 20 m (Refer to section 11.1.2.)			Standard cable outside panel
4)	SSCNET III cable	MR-J3BUS_M-B Cable length: 30 m to 50 m (Refer to section 11.1.2.)	Connector: CF-2D103-S (JAE)	Connector: CF-2D103-S (JAE)	Long-distance cable
					
5)	USB cable	MR-J3USBCBL3M Cable length: 3m	CN5 connector mini-B connector (5 pins)	Personal computer connector A connector	For connection with PC-AT compatible personal computer
					
6)	Connector set	MR-J2CMP2		Connector: 10126-3000PE Shell kit: 10326-52F0-008 (3M or equivalent)	Quantity: 1
7)	Connector set	MR-ECN1		Connector: 10126-3000PE Shell kit: 10326-52F0-008 (3M or equivalent)	Quantity: 20
8)	Junction terminal block cable	MR-TBNATBL_M Cable length: 0.5/1 m (Refer to section 11.12.)	Junction terminal block connector Connector: 10126-6000EL Shell kit: 10326-3210-000 (3M or equivalent)	Servo amplifier-side connector Connector: 10126-6000EL Shell kit: 10326-3210-000 (3M or equivalent)	For junction terminal block connection
					
9)	Junction terminal block	MR-TB26A	Refer to section 11.12.		

11. OPTIONS AND AUXILIARY EQUIPMENT

No.	Product	Model	Description	Application
10)	STO cable	MR-D05UDL3M-B	Connector set: 2069250-1 (TE Connectivity) 	Connection cable for the CN8 connector
11)	Battery cable	MR-BT6V1CBL_M Cable length: 0.3/1 m (Refer to section 11.1.3.)	Housing: PAP-02V-0 Contact: SPHD-001G0-P0.5 (JST) Connector: 10114-3000PE Shell kit: 10314-52F0-008 (3M or equivalent) 	For connection with battery unit
12)	Junction battery cable	MR-BT6V2CBL_M Cable length: 0.3/1 m (Refer to section 11.1.3.)	Housing: PAP-02V-0 Contact: SPHD-001G0-P0.5 (JST) Housing: PALR-02VF Contact: SPAL-001T-P0.5 (JST)  Housing: PAP-02V-0 Contact: SPHD-001G0-P0.5 (JST)	For battery junction
13)	Short-circuit connector			Supplied with servo amplifier

11. OPTIONS AND AUXILIARY EQUIPMENT

11.1.2 SSCNET III cable

POINT
<ul style="list-style-type: none"> ● Do not look directly at the light generated from CN1A/CN1B connector of servo amplifier or the end of SSCNET III cable. The light can be a discomfort when it enters the eye. ● Refer to appendix 9 for long distance cable over 50 m and ultra-long bending life cable.

(1) Model explanations

The numbers in the cable length field of the table indicate the symbol filling the underline "_" in the cable model. The cables of the lengths with the symbols are available.

Cable model	Cable length											Bending life	Application/remark
	0.15 m	0.3 m	0.5 m	1 m	3 m	5 m	10 m	20 m	30 m	40 m	50 m		
MR-J3BUS_M	015	03	05	1	3							Standard	Using inside panel standard cord
MR-J3BUS_M-A						5	10	20				Standard	Using outside panel standard cable
(Note) MR-J3BUS_M-B									30	40	50	Long bending life	Using long distance cable

Note. For cable of 30 m or less, contact your local sales office.

(2) Specifications

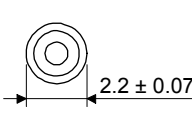
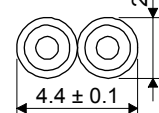
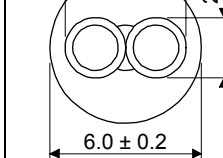
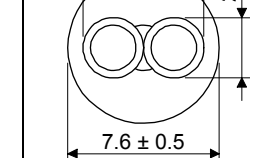
		Description			
SSCNET III cable model		MR-J3BUS_M		MR-J3BUS_M-A	MR-J3BUS_M-B
SSCNET III cable length		0.15 m	0.3 m to 3 m	5 m to 20 m	30 m to 50 m
Optical cable (cord)	Minimum bend radius	25 mm		Enforced covering cable 50 mm Cord: 25 mm	Enforced covering cable 50 mm Cord: 30 mm
	Tension strength	70 N	140 N	420 N (Enforced covering cable)	980 N (Enforced covering cable)
	Temperature range for use (Note)	-40 °C to 85 °C			-20 °C to 70 °C
	Ambience	Indoors (no direct sunlight) No solvent or oil			
External appearance [mm]					

Note. This temperature range for use is the value for optical cable (cord) only. Temperature condition for the connector is the same as that for servo amplifier.

11. OPTIONS AND AUXILIARY EQUIPMENT

- (3) Dimensions
 - (a) MR-J3BUS015M

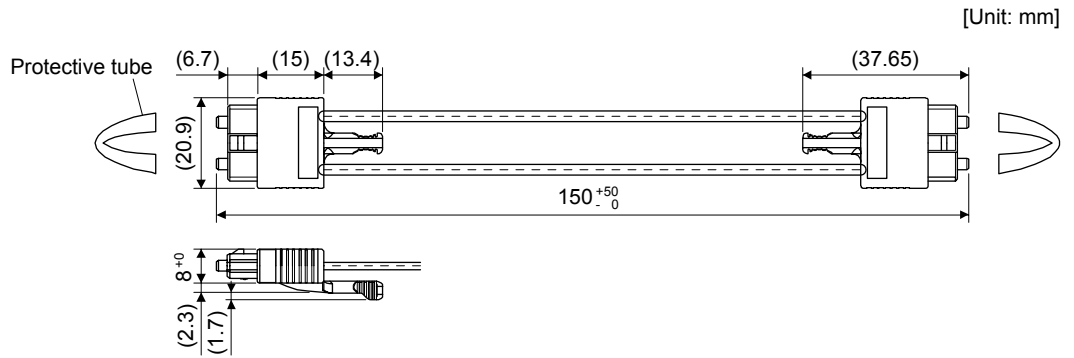

- (b) MR-J3BUS03M to MR-J3BUS3M
 - Refer to the table shown in (1) of this section for cable length (L).

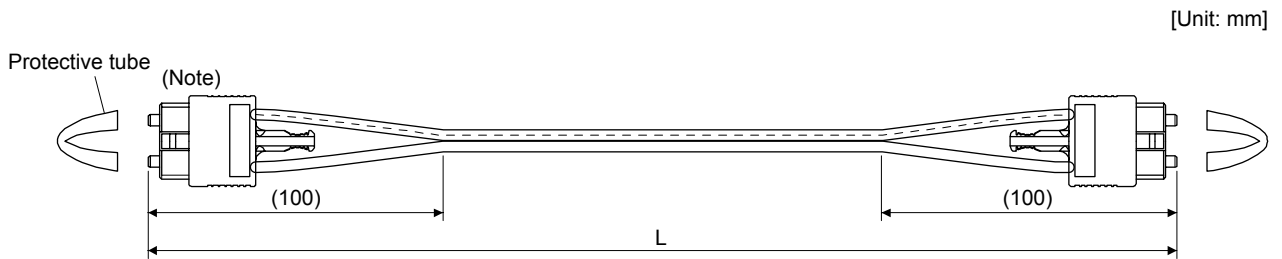

Note. Dimension of connector part is the same as that of MR-J3BUS015M.

- (c) MR-J3BUS5M-A to MR-J3BUS20M-A/MR-J3BUS30M-B to MR-J3BUS50M-B
 - Refer to the table shown in (1) of this section for cable length (L).

SSCNET III cable	Variable dimensions [mm]	
	A	B
MR-J3BUS5M-A to MR-J3BUS20M-A	100	30
MR-J3BUS30M-B to MR-J3BUS50M-B	150	50

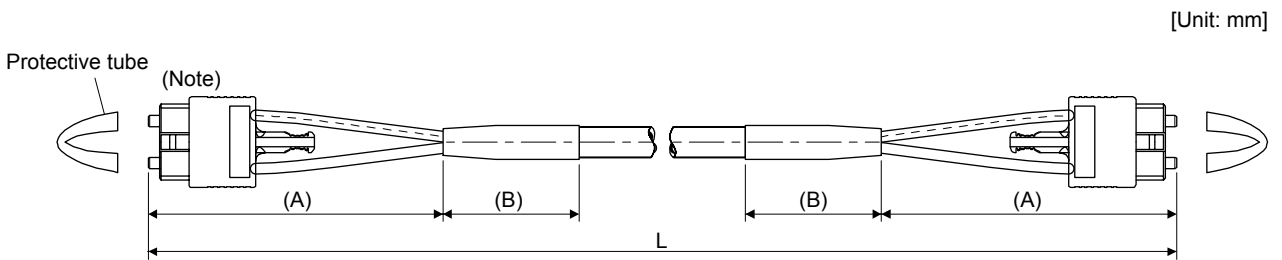

Note. Dimension of connector part is the same as that of MR-J3BUS015M.

11. OPTIONS AND AUXILIARY EQUIPMENT

11.1.3 Battery cable/junction battery cable

(1) Model explanations

The numbers in the cable length field of the table indicate the symbol filling the underline "_" in the cable model. The cables of the lengths with the symbols are available.

Cable model	Cable length		Bending life	Application/remark
	0.3 m	1 m		
MR-BT6V1CBL_M	03	1	Standard	For connection with MR-J4BTCASE
MR-BT6V2CBL_M	03	1	Standard	For junction

(2) MR-BT6V1CBL_M

(a) Appearance

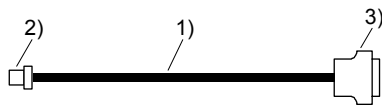

Components	Description
1) Cable	VSVC 7/0.18 × 2C
2) Connector	Housing: PAP-02V-0 Contact: SPHD-001G0-P0.5 (JST)
3) Connector	Connector: 10114-3000PE Shell kit: 10314-52F0-008 (3M or equivalent)

(b) Internal wiring diagram

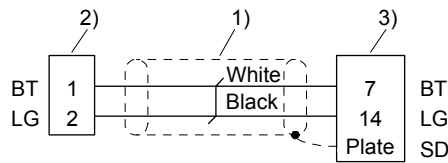

(3) MR-BT6V2CBL_M

(a) Appearance

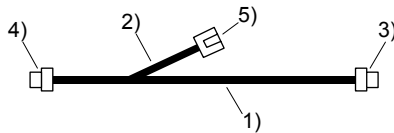

Components	Description
1) Cable	VSVC 7/0.18 × 2C
2) Cable	VSVC 7/0.18 × 2C
3) Connector	Housing: PAP-02V-0
4) Connector	Contact: SPHD-001G0-P0.5 (JST)
5) Connector	Housing: PALR-02VF Contact: SPAL-001T-P0.5 (JST)

(b) Internal wiring diagram

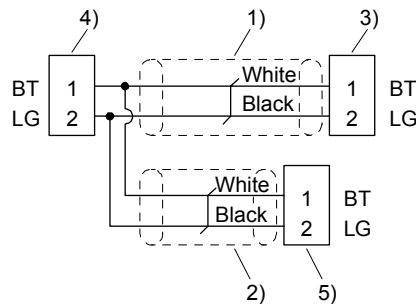

11. OPTIONS AND AUXILIARY EQUIPMENT

11.1.4 MR-D05UDL3M-B STO cable

This cable is for connecting an external device to the CN8 connector.

Cable model	Cable length	Application/remark
MR-D05UDL3M-B	3 m	Connection cable for the CN8 connector

(1) Configuration diagram

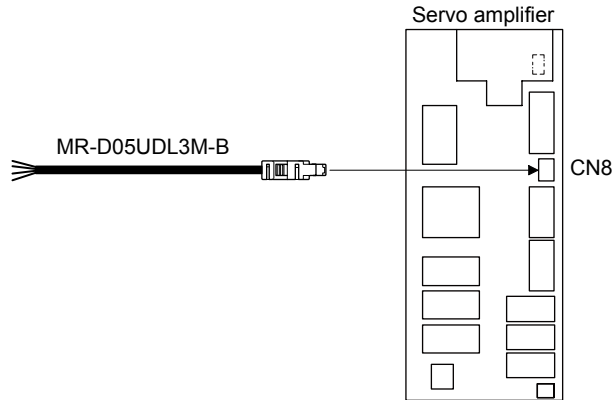

(2) Internal wiring diagram

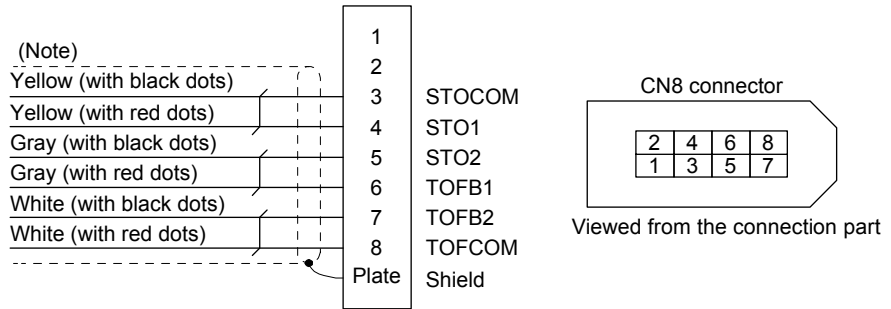

Note. Do not use the two core wires with orange sheath (with red or black dots).

11.2 Regenerative options

CAUTION Do not use servo amplifiers with regenerative options other than the combinations specified below. Otherwise, it may cause a fire.

11.2.1 Combination and regenerative power

The power values in the table are resistor-generated powers and not rated powers.

Servo amplifier	Regenerative power [W]			
	Built-in regenerative resistor	MR-RB14 [26 Ω]	MR-RB34 [26 Ω]	MR-RB3N [26 Ω]
MR-J4W2-22B	20	100		
MR-J4W2-44B				
MR-J4W2-77B	100			300
MR-J4W2-1010B				
MR-J4W3-222B	30	100	300	
MR-J4W3-444B				

11. OPTIONS AND AUXILIARY EQUIPMENT

11.2.2 Selection of regenerative option

Use the following method when regeneration occurs continuously in vertical motion applications or when it is desired to make an in-depth selection of the regenerative option.

(1) Regenerative energy calculation

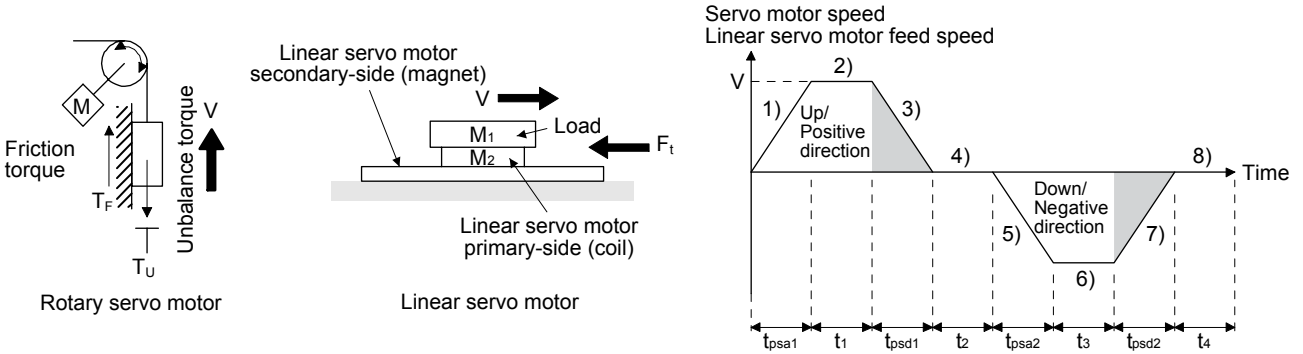

The following shows equations of the rotary servo motor torque and energy at the driving pattern above.

Section	Torque applied to servo motor [N·m]	Energy E [J]
1)	$T_1 = \frac{(J_L/\eta + J_M) \cdot V}{9.55 \times 10^4} \cdot \frac{1}{t_{psa1}} + T_U + T_F$	$E_1 = \frac{0.1047}{2} \cdot V \cdot T_1 \cdot t_{psa1}$
2)	$T_2 = T_U + T_F$	$E_2 = 0.1047 \cdot V \cdot T_2 \cdot t_1$
3)	$T_3 = \frac{-(J_L/\eta + J_M) \cdot V}{9.55 \times 10^4} \cdot \frac{1}{t_{psd1}} + T_U + T_F$	$E_3 = \frac{0.1047}{2} \cdot V \cdot T_3 \cdot t_{psd1}$
4), 8)	$T_4, T_8 = T_U$	$E_4, E_8 \geq 0$ (No regeneration)
5)	$T_5 = \frac{(J_L/\eta + J_M) \cdot V}{9.55 \times 10^4} \cdot \frac{1}{t_{psa2}} - T_U + T_F$	$E_5 = \frac{0.1047}{2} \cdot V \cdot T_5 \cdot t_{psa2}$
6)	$T_6 = -T_U + T_F$	$E_6 = 0.1047 \cdot V \cdot T_6 \cdot t_3$
7)	$T_7 = \frac{-(J_L/\eta + J_M) \cdot V}{9.55 \times 10^4} \cdot \frac{1}{t_{psd2}} - T_U + T_F$	$E_7 = \frac{0.1047}{2} \cdot V \cdot T_7 \cdot t_{psd2}$

The following shows equations of the linear servo motor thrust and energy.

Section	Thrust F of linear servo motor [N]	Energy E [J]
1)	$F_1 = (M_1 + M_2) \cdot V / t_{psa1} + F_t$	$E_1 = V / 2 \cdot F_1 \cdot t_{psa1}$
2)	$F_2 = F_t$	$E_2 = V \cdot F_2 \cdot t_1$
3)	$F_3 = -(M_1 + M_2) \cdot V / t_{psd1} + F_t$	$E_3 = V / 2 \cdot F_3 \cdot t_{psd1}$
4), 8)	$F_4, F_8 = 0$	$E_4, E_8 = 0$ (No regeneration)
5)	$F_5 = (M_1 + M_2) \cdot V / t_{psa2} + F_t$	$E_5 = V / 2 \cdot F_5 \cdot t_{psa2}$
6)	$F_6 = F_t$	$E_6 = V \cdot F_6 \cdot t_3$
7)	$F_7 = -(M_1 + M_2) \cdot V / t_{psd2} + F_t$	$E_7 = V / 2 \cdot F_7 \cdot t_{psd2}$

11. OPTIONS AND AUXILIARY EQUIPMENT

(2) Losses of servo motor and servo amplifier in regenerative mode

The following table lists the efficiencies and other data of the servo motor and servo amplifier in the regenerative mode.

Servo amplifier	Inverse efficiency [%]	Capacitor charging energy E_c [J]
MR-J4W2-22B	75	17
MR-J4W2-44B	85	21
MR-J4W2-77B	85	44
MR-J4W2-1010B	85	44
MR-J4W3-222B	75	21
MR-J4W3-444B	85	31

Inverse efficiency (η): Efficiency including some efficiencies of the servo motor and servo amplifier when rated (regenerative) torque is generated at rated speed. Since the efficiency varies with the speed and generated torque, allow for about 10%.

Capacitor charging energy (E_c): Energy charged into the electrolytic capacitor in the servo amplifier

(3) Calculation of regenerative energy per cycle

For example, calculate the regenerative energy in the following operation pattern with 3-axis servo amplifier.

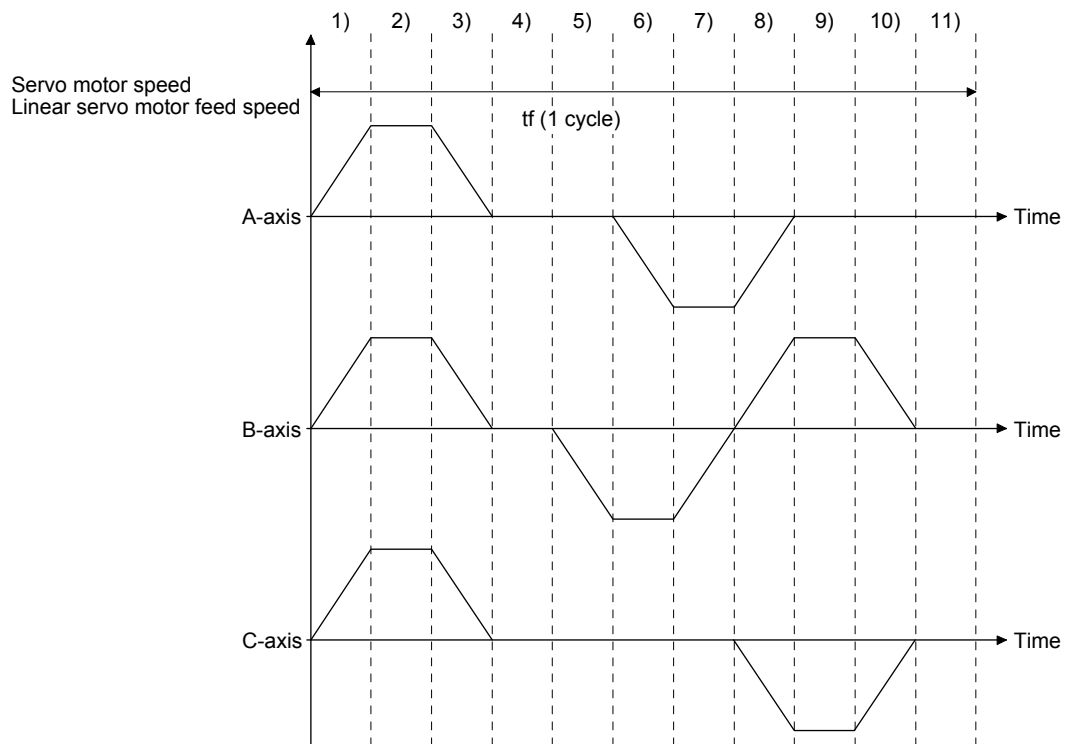

11. OPTIONS AND AUXILIARY EQUIPMENT

Calculate the energy at different timings in one cycle. Energy is a positive value in power running and a negative value in regeneration. Write down the energy during power running/regeneration with signs in the calculation table as shown below.

Timing	1)	2)	3)	4)	5)	6)	7)	8)	9)	10)	11)
A-axis	E1A	E2A	E3A	E4A	E5A	E6A	E7A	E8A	E9A	E10A	E11A
B-axis	E1B	E2B	E3B	E4B	E5B	E6B	E7B	E8B	E9B	E10B	E11B
C-axis	E1C	E2C	E3C	E4C	E5C	E6C	E7C	E8C	E9C	E10C	E11C
Sum	E1	E2	E3	E4	E5	E6	E7	E8	E9	E10	E11

Calculate the energy consumed by the regenerative resistor with the following equation for the calculation results from E1 to E11 with a negative value.

When the absolute value of the value in E1 to E11 is assumed to be E_s : $ER [J] = \eta \cdot E_s - E_c$

If ER values are negative at all timings, the regenerative option is not needed. If any of ER values is positive, calculate the energy consumed by the regenerative resistor in one cycle from the time for one cycle and the sum of the positive ER values.

$PR [W] = \text{Sum of the positive ER values} / \text{Operating time (tf) for one cycle}$

Regenerative option is not required when PR is equal to or less than the specification value of the servo amplifier built-in regenerative energy.

11.2.3 Parameter setting

Set [Pr. PA02] according to the option to be used.

[Pr. PA02]

0	0		
---	---	--	--

Regenerative option selection
 00: Regenerative option is not used. (Built-in regenerative resistor is used.)
 0B: MR-RB3N
 0D: MR-RB14
 0E: MR-RB34

11. OPTIONS AND AUXILIARY EQUIPMENT

11.2.4 Connection of regenerative option

POINT

● For the sizes of wires used for wiring, refer to section 11.5.

The regenerative option generates heat of 100 °C higher than the ambient temperature. Fully consider heat dissipation, installation position, wires used, etc. before installing the option. For wiring, use flame-resistant wires or make the wires flame-resistant and keep them away from the regenerative option. Always use twisted cables of max. 5 m length for connection with the servo amplifier.

Connect the regenerative option to P+ and C. G3 and G4 are thermal sensor's terminals. Between G3 and G4 is opened when the regenerative option overheats abnormally.

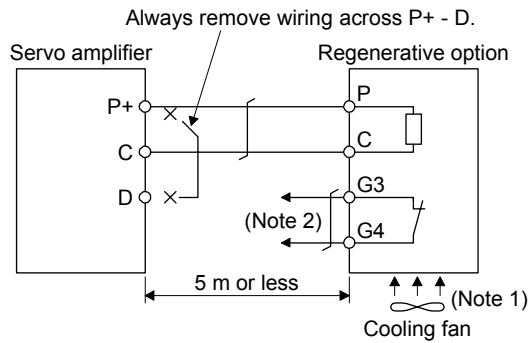

Note 1. When the ambient temperature is more than 55 °C and the regenerative load ratio is more than 60% in MR-RB34 and MR-RB3N, forcefully cool the air with a cooling fan (1.0 m³/min or more, 92 mm × 92 mm). A cooling fan is not required if the ambient temperature is 35 °C or less. (A cooling fan is required for the shaded area in the following graph.)

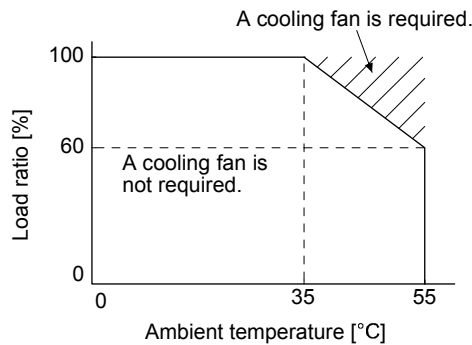

A cooling fan is not required for MR-RB14.

2. Make up a sequence which will switch off the magnetic contactor when abnormal heating occurs.

G3-G4 contact specifications

Maximum voltage: 120 V AC/DC

Maximum current: 0.5 A/4.8 V DC

Maximum capacity: 2.4 VA

11. OPTIONS AND AUXILIARY EQUIPMENT

11.2.5 Dimensions

(1) MR-RB14

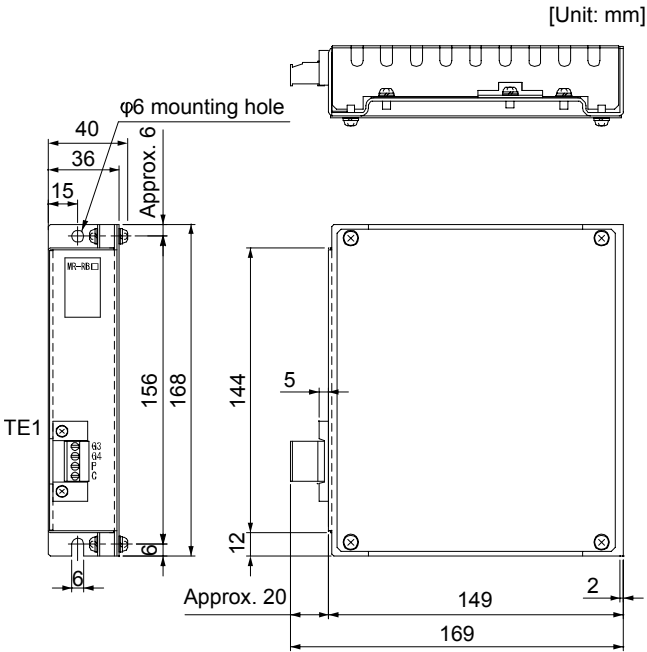

• TE1 terminal block

G3
G4
P
C

Applicable wire size: 0.2 mm² to 2.5 mm² (AWG14 to 12)
Tightening torque: 0.5 to 0.6 [N•m]

• Mounting screw
Screw size: M5
Tightening torque: 3.24 [N•m]

Mass: 1.1 [kg]

(2) MR-RB34/MR-RB3N

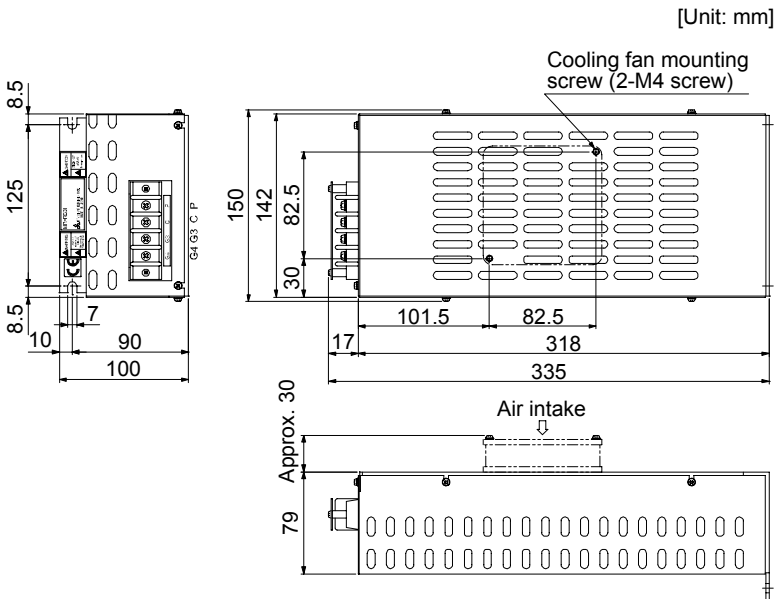

• Terminal block

P
C
G3
G4

Terminal screw size: M4
Tightening torque: 1.2 [N•m]

• Mounting screw
Screw size: M6
Tightening torque: 5.4 [N•m]

Mass: 2.9 [kg]

11. OPTIONS AND AUXILIARY EQUIPMENT

11.3 MR-BT6VCASE battery case and MR-BAT6V1 battery

POINT
● Refer to appendix 2 and 3 for battery transportation and the new EU Battery Directive.

(1) Purpose of use for the battery unit

This battery is used to construct an absolute position detection system. An MR-BT6VCASE battery case is a case that stores five MR-BAT6V1 batteries by connector connections. An MR-BT6VCASE battery case can be used by eight axes of the servo amplifiers at maximum. To connect an MR-BT6VCASE battery case to a servo amplifier, MR-BT6V1CBL_M battery cable is required. To connect multiple servo amplifiers to an MR-BT6VCASE battery case, use MR-BT6V2CBL_M junction battery cable. When using a servo amplifier in the incremental system, MR-BT6VCASE and MR-BAT6V1 are not required. Refer to section 12.3 for the usage, etc.

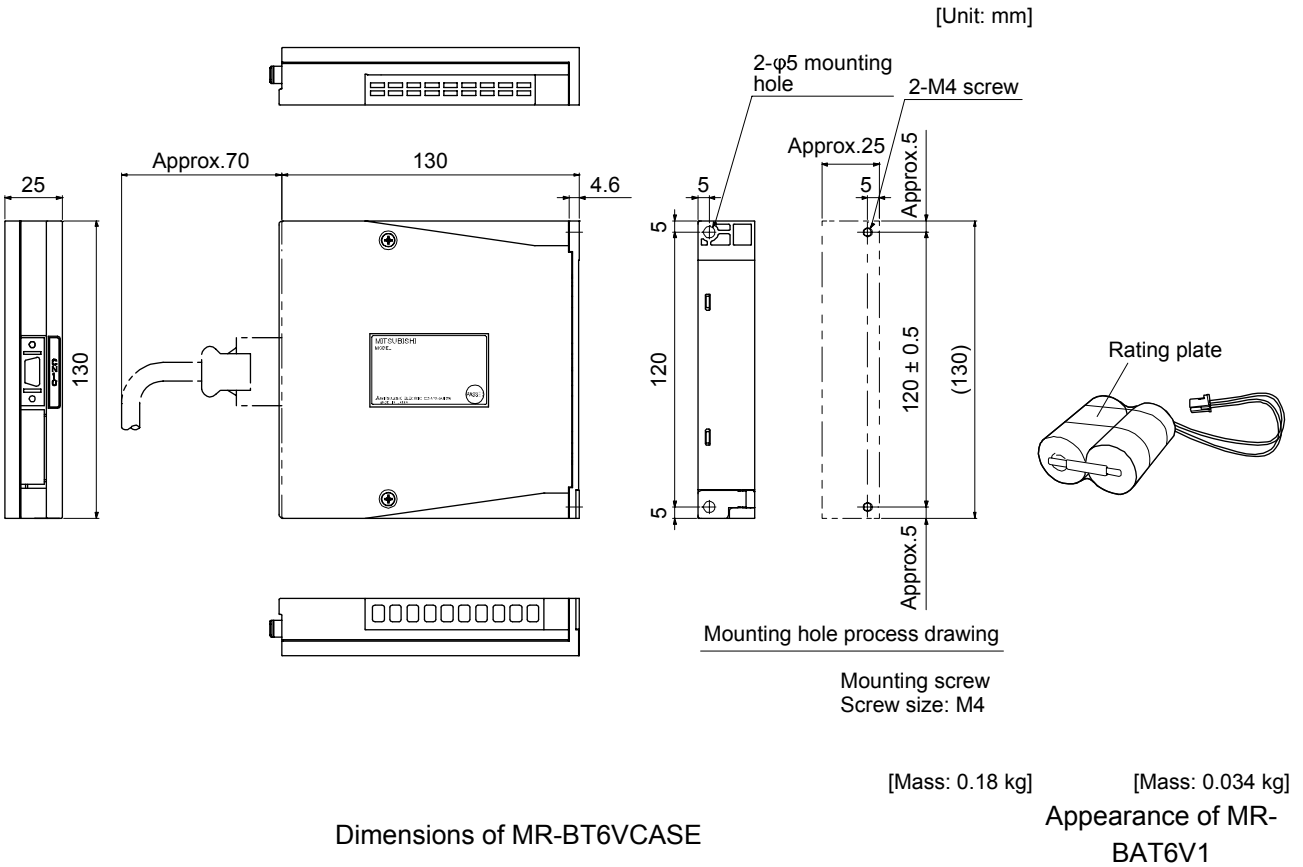

(2) Year and month when the battery is manufactured

The manufacturing years of MR-BAT6V1 have been described to the rating plate put on the battery.

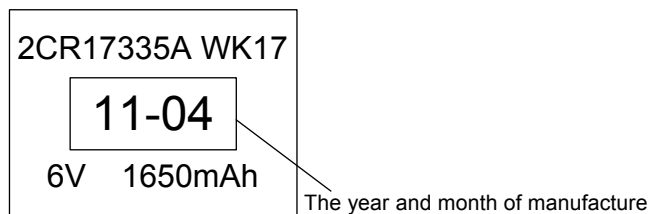

11. OPTIONS AND AUXILIARY EQUIPMENT

11.4 MR Configurator2

MR Configurator2 (SW1DNC-MRC2-E) uses the communication function of the servo amplifier to perform parameter setting changes, graph display, test operation, etc. on a personal computer.

(1) Specifications

Item	Description
Project	Create/read/save/delete project, read/write other format, system setting, print
Parameter	Parameter setting
Monitor	Display all, I/O monitor, graph, ABS data display
Diagnosis	Alarm display, alarm onset data, drive recorder, no motor rotation, system configuration, life diagnosis, machine diagnosis, fully closed loop diagnosis (Note 2), linear diagnosis (Note 3)
Test mode	Jog mode (Note 4), positioning mode, motor-less operation (Note 1), DO forced output, program operation, test mode information
Adjustment	One-touch tuning, tuning, machine analyzer
Others	Servo assistant, parameter setting range update, machine unit conversion setting, help display

- Note
1. This is available only in the standard control mode. This will be available in the fully closed loop control mode, linear servo motor control mode, and direct drive motor control mode in the future.
 2. This is available only in the fully closed loop control mode.
 3. This is available only in the linear servo motor control mode.
 4. This is available in the standard control mode, fully closed loop control mode, and DD motor control mode.

11. OPTIONS AND AUXILIARY EQUIPMENT

(2) System configuration

(a) Components

To use this software, the following components are required in addition to the servo amplifier and servo motor.

Equipment		(Note 1) Description
(Note 2, 3, 4, 5) Personal computer	OS	Microsoft® Windows® 7 Enterprise [Service Pack none/1] Microsoft® Windows® 7 Ultimate [Service Pack none/1] Microsoft® Windows® 7 Professional [Service Pack none/1] Microsoft® Windows® 7 Home Premium [Service Pack none/1] Microsoft® Windows® 7 Starter [Service Pack none/1] Microsoft® Windows Vista® Enterprise [Service Pack none/1/2] Microsoft® Windows Vista® Ultimate [Service Pack none/1/2] Microsoft® Windows Vista® Business [Service Pack none/1/2] Microsoft® Windows Vista® Home Premium [Service Pack none/1/2] Microsoft® Windows Vista® Home Basic [Service Pack none/1/2] Microsoft® Windows® XP Professional [Service Pack 2/3] Microsoft® Windows® XP Home Edition [Service Pack 2/3] Microsoft® Windows® 2000 Professional [Service Pack 4]
	CPU	Desktop PC: Intel® Celeron® processor 2.8GHz or more. Laptop PC: Intel® Pentium® M processor 1.7GHz or more.
	Memory	512 MB or more (for 32-bit OS) and 1 GB or more (for 64-bit OS)
	Hard Disk	1 GB or more of free space
	Communication interface	USB port
Browser	Windows® Internet Explorer® 4.0 or more (Note 1)	
Display	One whose resolution is 1024 × 768 or more and that can provide a high color (16 bit) display. Connectable with the above personal computer.	
Keyboard	Connectable with the above personal computer.	
Mouse	Connectable with the above personal computer.	
Printer	Connectable with the above personal computer.	
USB cable	MR-J3USBCBL3M	

Note 1. Microsoft, Windows, Internet Explorer and Windows Vista are registered trademarks of Microsoft Corporation in the United States and other countries.

Celeron and Pentium are the registered trademarks of Intel Corporation.

2. On some personal computers, MR Configurator2 may not run properly.

3. When Microsoft® Windows® 7, Microsoft® Windows Vista®, or Microsoft® Windows® XP is used, the following functions cannot be used.

- Windows Program Compatibility mode
- Fast User Switching
- Remote Desktop
- Large Fonts Mode (Display property)
- DPI settings other than 96DPI (Display property)

For 64-bit operating system, this software is compatible with Windows® 7.

4. When Windows® 7 is used, the following functions cannot be used.

- Windows XP Mode
- Windows touch

5. When using this software with Windows Vista® and Windows® 7, log in as a user having USER authority or higher.

11. OPTIONS AND AUXILIARY EQUIPMENT

(b) Connection with servo amplifier

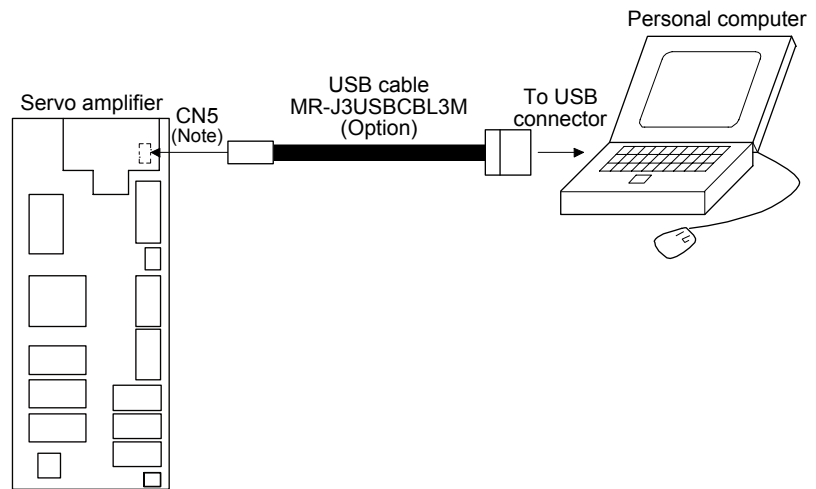

Note. CN5 is located under the display cover.

11.5 Selection example of wires

POINT
● Refer to section 11.1.2 for SSCNET III cable.
● To comply with the UL/CSA standard, use the wires shown in appendix 5 for wiring. To comply with other standards, use a wire that is complied with each standard.
● Selection condition of wire size is as follows. Construction condition: One wire is constructed in the air Wire length: 30 m or less

11. OPTIONS AND AUXILIARY EQUIPMENT

(1) Wires for power supply wiring

The following diagram shows the wires used for wiring. Use the wires given in this section or equivalent.

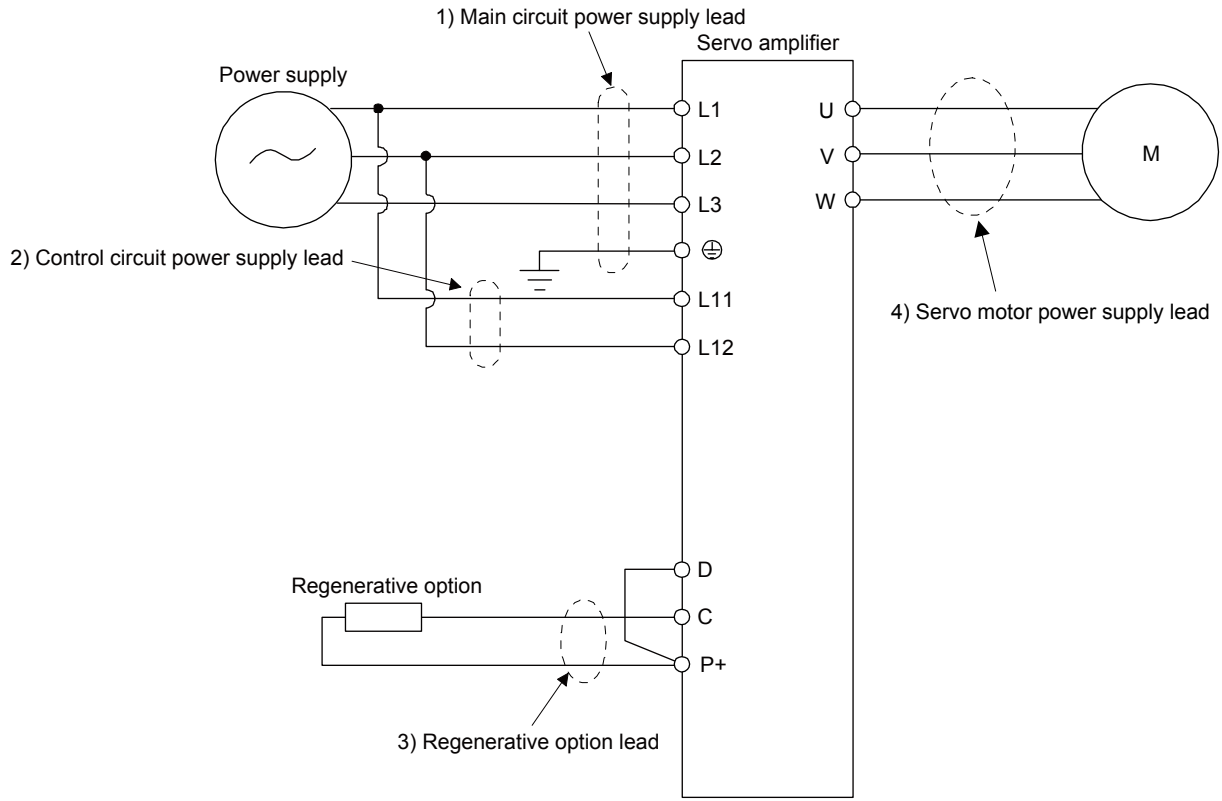

The following table shows the wire size selection example.

Table 11.1 Wire size selection example (HIV wire)

Servo amplifier	Wires [mm ²]			
	1) L1/L2/L3/⊕ (Note 1)	2) L11/L21	3) P+/C/D	4) U/V/W/⊕ (Note 2)
MR-J4W2-22B	2(AWG14)			AWG 18 to 14
MR-J4W2-44B				
MR-J4W2-77B				
MR-J4W2-1010B				
MR-J4W3-222B				
MR-J4W3-444B				

Note 1. Use the crimp terminal specified as below for the PE terminal of the servo amplifier.

Crimp terminal: FVD2-4

Tool: YNT-1614

Manufacturer: JST

Tightening torque: 1.2 [N·m]

2. The wire size shows applicable size of the servo amplifier connector. For wires connecting to the servo motor, refer to each servo amplifier instruction manual.

11. OPTIONS AND AUXILIARY EQUIPMENT

11.6 Molded-case circuit breakers, fuses, magnetic contactors (recommended)

Always use one molded-case circuit breaker and one magnetic contactor with one servo amplifier. When using a fuse instead of the molded-case circuit breaker, use the one having the specifications given in this section.

When using a combination of the rotary servo motor, linear servo motor, or direct drive motor, select a molded-case circuit breaker, a fuse or a magnetic contactor tentatively, assuming one type of the servo motors are used for two or three axes. After the tentative selections are made for all types of the servo motors, use the largest among all molded-case circuit breakers, fuses, or magnetic contactors.

(1) For main circuit power supply

(a) For MR-J4W2

Total output of rotary servo motors	Total continuous thrust of linear servo motors	Total output of direct drive motors	Molded-case circuit breaker		Fuse			(Note 2) Magnetic contactor
			Frame, rated current	Voltage AC [V]	(Note 1) Class	Current [A]	Voltage AC [V]	
300 W or less			50 A frame 5 A (Note 3)	240	T	15	300	S-N10
From over 300 W to 600 W	150 N or less	100 W or less	50 A frame 10 A (Note 3)			20		
From over 600 W to 1 kW	From over 150 N to 300 N	From over 100 W to 252 W	50 A frame 15 A (Note 3)			20		
From over 1 kW to 2 kW	From over 300 N to 480 N	From over 252 W to 838 W	50 A frame 20 A (Note 3)			30	S-N20 (Note 4)	

- Note
1. When using the servo amplifier as a UL/CSA standard compliant product, refer to appendix 5.
 2. Use a magnetic contactor with an operation delay time (interval between current being applied to the coil until closure of contacts) of 80 ms or less.
 3. When not using the servo amplifier as a UL/CSA standard compliant product, molded-case circuit breaker of 30 A frame can be used.
 4. S-N18 can be used when auxiliary contact is not required.

(b) For MR-J4W3

Total output of rotary servo motors	Total continuous thrust of linear servo motors	Total output of direct drive motors	Molded-case circuit breaker		Fuse			(Note 2) Magnetic contactor
			Frame, rated current	Voltage AC [V]	(Note 1) Class	Current [A]	Voltage AC [V]	
450 W or less	150 N or less		50 A frame 10 A (Note 3)	240	T	20	300	S-N10
From over 450 W to 800 W	From over 150 N to 300 N	252 W or less	50 A frame 15 A (Note 3)			20		
From over 800 W to 1.5 kW	From over 300 N to 450 N	From over 252 W to 378 W	50 A frame 20 A (Note 3)			30	S-N20	

- Note
1. When using the servo amplifier as a UL/CSA standard compliant product, refer to appendix 5.
 2. Use a magnetic contactor with an operation delay time (interval between current being applied to the coil until closure of contacts) of 80 ms or less.
 3. When not using the servo amplifier as a UL/CSA standard compliant product, molded-case circuit breaker of 30 A frame can be used.

11. OPTIONS AND AUXILIARY EQUIPMENT

(2) For control circuit power supply

When the wiring for the control circuit power supply (L11, L21) is thinner than that for the main circuit power supply (L1, L2, L3), install an overcurrent protection device (molded-case circuit breaker or fuse) to protect the branch circuit.

Servo amplifier	Molded-case circuit breaker		Fuse (Class T)		Fuse (Class K5)	
	Frame, rated current	Voltage AC [V]	Current [A]	Voltage AC [V]	Current [A]	Voltage AC [V]
MR-J4W2-22B	50 A frame 5 A (Note)	240	1	300	1	250
MR-J4W2-44B						
MR-J4W2-77B						
MR-J4W2-1010B						
MR-J4W3-222B						
MR-J4W3-444B						

Note. When not using the servo amplifier as a UL/CSA standard compliant product, molded-case circuit breaker of 30 A frame can be used.

11.7 Power factor improving AC reactors

The following shows the advantages of using power factor improving AC reactor.

- It improves the power factor by increasing the form factor of the servo amplifier's input current.
- It decreases the power supply capacity.
- The input power factor is improved to be about 80%.

When using power factor improving reactors for two servo amplifiers or more, be sure to connect a power factor improving reactor to each servo amplifier. If using only one power factor improving reactor, enough improvement effect of phase factor cannot be obtained unless all servo amplifiers are operated.

When using a combination of the rotary servo motor, linear servo motor, or direct drive motor, select a power factor improving AC reactor tentatively, assuming one type of the servo motors are used for 2 or 3 axes.

After the tentative selections are made for all types of the servo motors, use the largest among all power factor improving AC reactors.

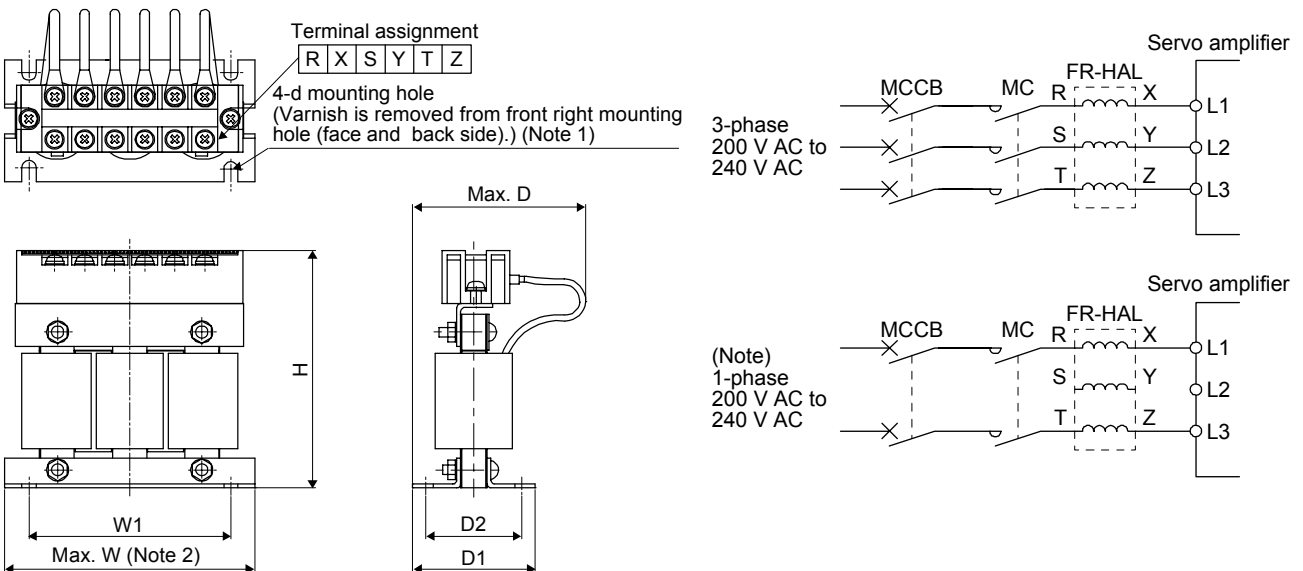

Note 1. Use this for grounding.

2. $W \pm 2$ is applicable for FR-HAL-0.4K to FR-HAL-1.5K.

Note. For 1-phase 200 V AC to 240 V AC, connect the power supply to L1 and L3. Leave L2 open.

11. OPTIONS AND AUXILIARY EQUIPMENT

(1) For MR-J4W2

Total output of rotary servo motors	Total continuous thrust of linear servo motors	Total output of direct drive motors	Power factor improving AC reactor
450 W or less	150 N or less	100 W or less	FR-HAL-0.75K
From over 450 W to 600 W	From over 150 N to 240 N	From over 100 W to 377 W	FR-HAL-1.5K
From over 600 W to 1 kW	From over 240 N to 300 N	From over 377 W to 545 W	FR-HAL-2.2K
From over 1 kW to 20 kW	From over 300 N to 480 N	From over 545 W to 838 W	FR-HAL-3.7K

(2) For MR-J4W3

Total output of rotary servo motors	Total continuous thrust of linear servo motors	Total output of direct drive motors	Power factor improving AC reactor
450 W or less	150 N or less		FR-HAL-0.75K
From over 450 W to 600 W	From over 150 N to 240 N	378 W or less	FR-HAL-1.5K
From over 600 W to 1 kW	From over 240 N to 300 N		FR-HAL-2.2K
From over 1 kW to 20 kW	From over 300 N to 450 N		FR-HAL-3.7K

(3) Dimensions

Power factor improving AC reactor	Dimensions [mm]							Terminal size	Mass [kg]
	W	W1	H	D (Note 1)	D1	D2	d		
FR-HAL-0.75K	104	84	99	74	56	44	M5	M4	0.8
FR-HAL-1.5K	104	84	99	77	61	50	M5	M4	1.1
FR-HAL-2.2K	115 (Note 1)	40	115	77	71	57	M6	M4	1.5
FR-HAL-3.7K	115 (Note 1)	40	115	83	81	67	M6	M4	2.2

- Note 1. Maximum dimension. The dimension varies depending on the input/output lines.
 2. Selection condition of wire size is as follows.
 600 V grade heat-resistant polyvinyl chloride insulated wire (HIV wire)
 Construction condition: One wire is constructed in the air

11.8 Relays (recommended)

The following relays should be used with the interfaces

Interface	Selection example
Digital input interface DI-1 Relay used for digital input command signals	To prevent defective contacts, use a relay for small signal (twin contacts). (Ex.) Omron : type G2A, MY
Digital output (interface DO-1) Relay used for digital output signals	Small relay with 12 V DC or 24 V DC of rated current 40 mA or less (Ex.) Omron : type MY

11.9 Noise reduction techniques

Noises are classified into external noises which enter the servo amplifier to cause it to malfunction and those radiated by the servo amplifier to cause peripheral devices to malfunction. Since the servo amplifier is an electronic device which handles small signals, the following general noise reduction techniques are required. Also, the servo amplifier can be a source of noise as its outputs are chopped by high carrier frequencies. If peripheral devices malfunction due to noises produced by the servo amplifier, noise suppression measures must be taken. The measures will vary slightly with the routes of noise transmission.

11. OPTIONS AND AUXILIARY EQUIPMENT

(1) Noise reduction techniques

(a) General reduction techniques

- Avoid laying power lines (input and output cables) and signal cables side by side or do not bundle them together. Separate power lines from signal cables.
- Use a shielded twisted pair cable for connection with the encoder and for control signal transmission, and connect the external conductor of the cable to the SD terminal.
- Ground the servo amplifier, servo motor, etc. together at one point. (Refer to section 3.12.)

(b) Reduction techniques for external noises that cause the servo amplifier to malfunction

If there are noise sources (such as a magnetic contactor, an electromagnetic brake, and many relays which make a large amount of noise) near the servo amplifier and the servo amplifier may malfunction, the following countermeasures are required.

- Provide surge absorbers on the noise sources to suppress noises.
- Attach data line filters to the signal cables.
- Ground the shields of the encoder connecting cable and the control signal cables with cable clamp fittings.
- Although a surge absorber is built into the servo amplifier, to protect the servo amplifier and other equipment against large exogenous noise and lightning surge, attaching a varistor to the power input section of the equipment is recommended.

(c) Techniques for noises radiated by the servo amplifier that cause peripheral devices to malfunction

Noises produced by the servo amplifier are classified into those radiated from the cables connected to the servo amplifier and its main circuits (input and output circuits), those induced electromagnetically or statically by the signal cables of the peripheral devices located near the main circuit cables, and those transmitted through the power supply cables.

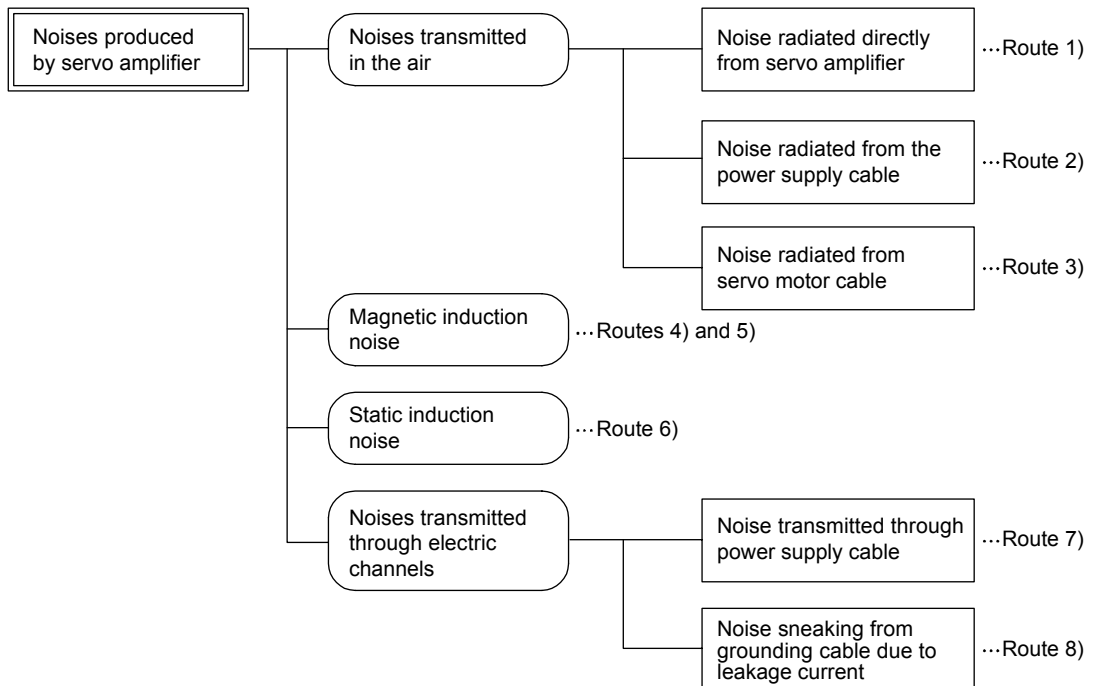

11. OPTIONS AND AUXILIARY EQUIPMENT

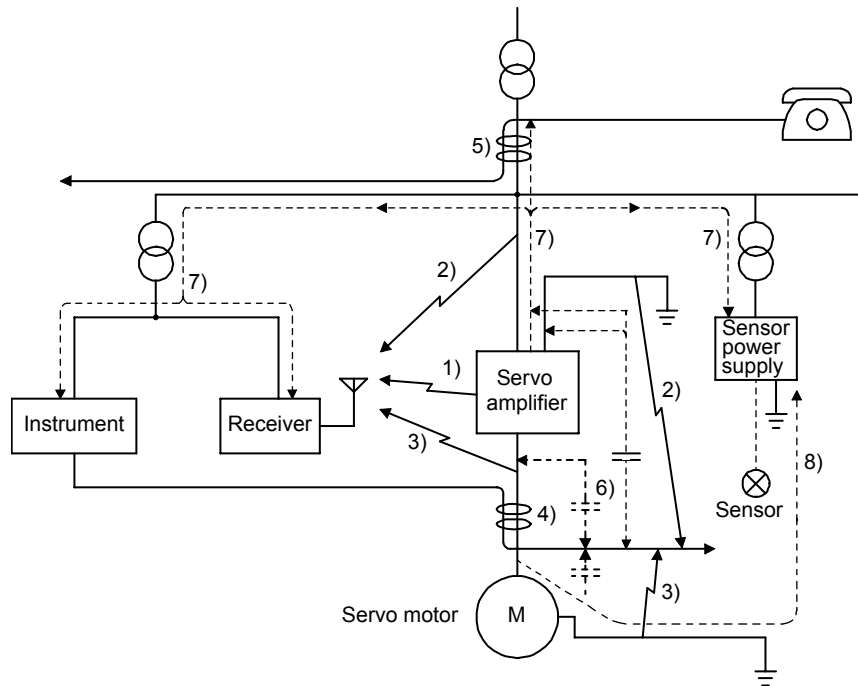

Noise transmission route	Suppression techniques
1) 2) 3)	<p>When measuring instruments, receivers, sensors, etc. which handle weak signals and may malfunction due to noise and/or their signal cables are contained in a cabinet together with the servo amplifier or run near the servo amplifier, such devices may malfunction due to noises transmitted through the air. The following techniques are required.</p> <ol style="list-style-type: none"> 1. Provide maximum clearance between easily affected devices and the servo amplifier. 2. Provide maximum clearance between easily affected signal cables and the I/O cables of the servo amplifier. 3. Avoid wiring the power lines (input/output lines of the servo amplifier) and signal lines side by side or bundling them together. 4. Insert a line noise filter to the I/O cables or a radio noise filter on the input line. 5. Use shielded wires for signal and power lines or put lines in separate metal conduits.
4) 5) 6)	<p>When the power lines and the signal lines are laid side by side or bundled together, magnetic induction noise and static induction noise will be transmitted through the signal cables and malfunction may occur. The following techniques are required.</p> <ol style="list-style-type: none"> 1. Provide maximum clearance between easily affected devices and the servo amplifier. 2. Provide maximum clearance between easily affected signal cables and the I/O cables of the servo amplifier. 3. Avoid wiring the power lines (input/output lines of the servo amplifier) and signal lines side by side or bundling them together. 4. Use shielded wires for signal and power lines or put lines in separate metal conduits.
7)	<p>When the power supply of peripheral devices is connected to the power supply of the servo amplifier system, noises produced by the servo amplifier may be transmitted back through the power supply cable and the devices may malfunction. The following techniques are required.</p> <ol style="list-style-type: none"> 1. Install the radio noise filter (FR-BIF) on the power lines (Input lines) of the servo amplifier. 2. Install the line noise filter (FR-BSF01) on the power lines of the servo amplifier.
8)	<p>When the cables of peripheral devices are connected to the servo amplifier to make a closed loop circuit, leakage current may flow to malfunction the peripheral devices. If so, malfunction may be prevented by disconnecting the grounding cable of the peripheral device.</p>

11. OPTIONS AND AUXILIARY EQUIPMENT

(2) Noise reduction techniques

(a) Data line filter (recommended)

Noise can be prevented by installing a data line filter onto the encoder cable, etc.

For example, ZCAT3035-1330 by TDK, ESD-SR-250 by NEC TOKIN, and GRFC-13 by Kitagawa Industries are available as data line filters.

As a reference example, the impedance specifications of the ZCAT3035-1330 (TDK) are indicated below. These impedances are reference values and not guaranteed values.

Impedance [Ω]	
10 MHz to 100 MHz	100 MHz to 500 MHz
80	150

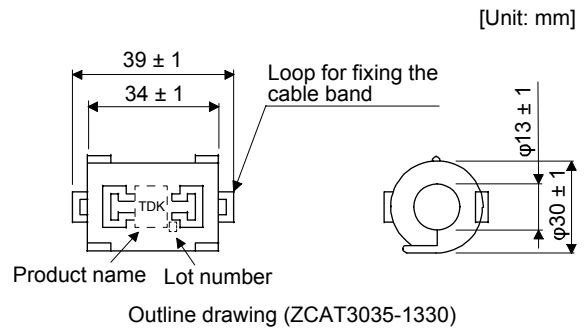

(b) Surge killer (recommended)

Use of a surge killer is recommended for AC relay, magnetic contactor or the like near the servo amplifier. Use the following surge killer or equivalent.

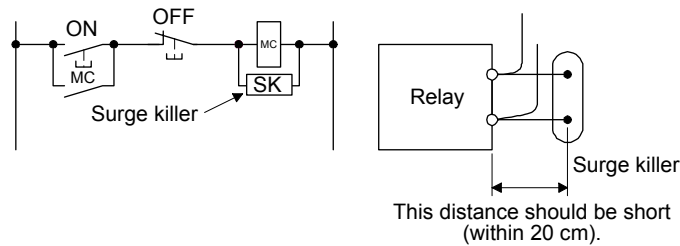

(Ex.) CR-50500 Okaya Electric Industries

Rated voltage AC [V]	C [$\mu\text{F} \pm 20\%$]	R [$\Omega \pm 30\%$]	Test voltage
250	0.5	50 (1/2 W)	Between terminals: 625 V AC, 50 Hz/60 Hz 60 s Between terminal and case: 2000 V AC, 50 Hz/60 Hz 60 s

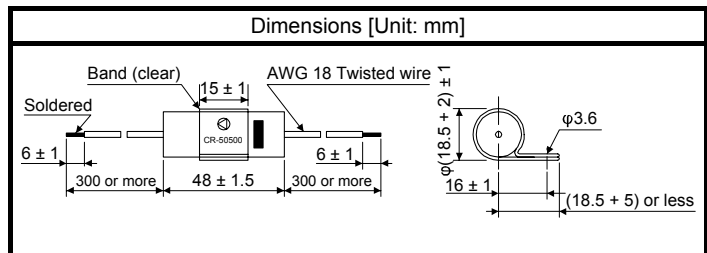

Note that a diode should be installed to a DC relay or the like.

Maximum voltage: Not less than four times the drive voltage of the relay or the like.

Maximum current: Not less than twice the drive current of the relay or the like.

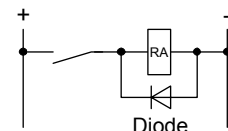

11. OPTIONS AND AUXILIARY EQUIPMENT

(c) Cable clamp fitting AERSBAN-_SET

Generally, the grounding of the shielded wire may only be connected to the connector's SD terminal. However, the effect can be increased by directly connecting the cable to an grounding plate as shown below.

Install the grounding plate near the servo amplifier for the encoder cable. Peel part of the cable sheath to expose the external conductor, and press that part against the grounding plate with the cable clamp.

If the cable is thin, clamp several cables in a bunch. The clamp comes as a set with the grounding plate.

[Unit: mm]

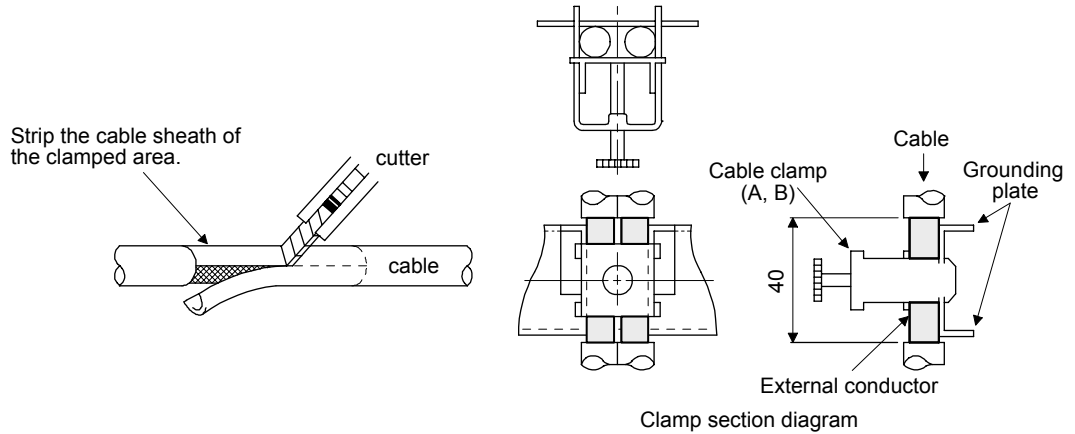

• Dimensions

[Unit: mm]

[Unit: mm]

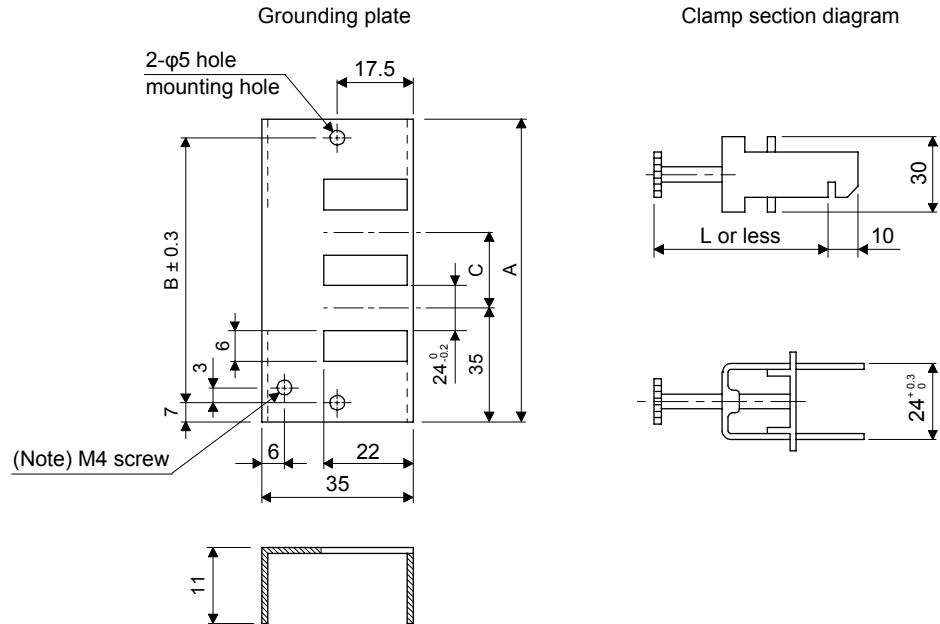

Note. Screw hole for grounding. Connect it to the grounding plate of the cabinet.

Model	A	B	C	Accessory fittings
AERSBAN-DSET	100	86	30	Clamp A: 2 pcs.
AERSBAN-ESET	70	56		Clamp B: 1 pc.

Clamp fitting	L
A	70
B	45

11. OPTIONS AND AUXILIARY EQUIPMENT

(d) Line noise filter (FR-BSF01)

This filter is effective in suppressing noises radiated from the power supply side and output side of the servo amplifier and also in suppressing high-frequency leakage current (0-phase current). It especially affects the noises between 0.5 MHz and 500 MHz band.

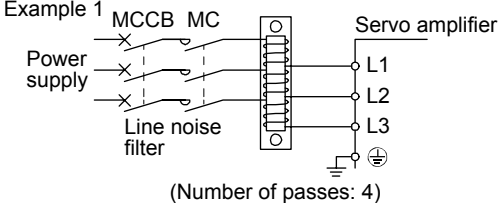
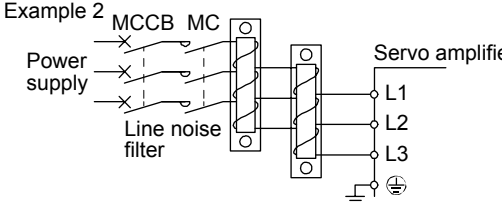
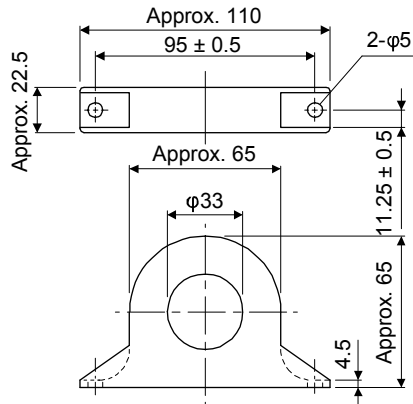
Connection diagram	Dimensions [Unit: mm]
<p>Use the line noise filters for lines of the main power supply (L1, L2, and L3) and of the servo motor power (U, V, and W). Pass each of the wires through the line noise filter an equal number of times in the same direction. For the main power supply, the effect of the filter rises as the number of passes increases, but generally four passes would be appropriate. For the servo motor power lines, passes must be four times or less. Do not pass the grounding wire through the filter, or the effect of the filter will drop. Wind the wires by passing through the filter to satisfy the required number of passes as shown in Example 1. If the wires are too thick to wind, use two or more filters to have the required number of passes as shown in Example 2.</p> <p>Place the line noise filters as close to the servo amplifier as possible for their best performance.</p> <p>Example 1</p>  <p>(Number of passes: 4)</p> <p>Example 2</p>  <p>Two filters are used (Total number of passes: 4)</p>	<p>FR-BSF01 (for wire size 3.5 mm² (AWG 12) or less)</p> 

11. OPTIONS AND AUXILIARY EQUIPMENT

(e) Radio noise filter (FR-BIF)

This filter is effective in suppressing noises radiated from the power supply side of the servo amplifier especially in 10 MHz and lower radio frequency bands. The FR-BIF is designed for the input only.

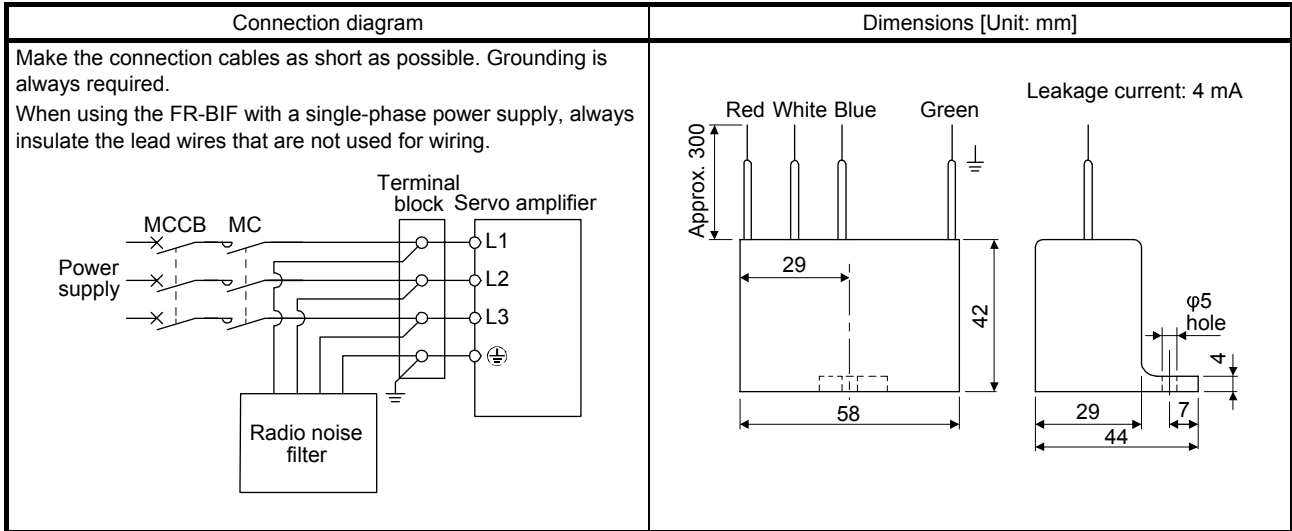

(f) Varistor for input power supply (recommended)

Varistors are effective to prevent exogenous noise and lightning surge from entering the servo amplifier. When using a varistor, connect it between each phase of the input power supply of the equipment. For varistors, the TND20V-431K and TND20V-471K, manufactured by NIPPON CHEMI-CON, are recommended. For detailed specification and usage of the varistors, refer to the manufacturer catalog.

Varistor	Maximum rated					Maximum limit voltage		Static capacity (reference value)	Varistor voltage rating (range) V1 mA
	Permissible circuit voltage		Surge current immunity	Energy immunity	Rated pulse power	[A]	[V]		
	AC [Vrms]	DC [V]	8/20 μ s [A]	2 ms [J]	[W]			[pF]	[V]
TND20V-431K	275	350	10000/1 time	195	1.0	100	710	1300	430 (387 to 473)
TND20V-471K	300	385	7000/2 times	215			775	1200	470 (423 to 517)

Model	[Unit: mm]							
	D	H	T	E	(Note) L	ϕ d	W	
	Max.	Max.	Max.	± 1.0	min.	± 0.05	± 1.0	
TND20V-431K	21.5	24.5	6.4	3.3	20	0.8	10.0	
TND20V-471K			6.6	3.5				

Note. For special purpose items for lead length (L), contact the manufacturer.

11. OPTIONS AND AUXILIARY EQUIPMENT

11.10 Earth-leakage current breaker

(1) Selection method

High-frequency chopper currents controlled by pulse width modulation flow in the AC servo circuits. Leakage currents containing harmonic contents are larger than those of the motor which is run with a commercial power supply.

Select an earth-leakage current breaker according to the following formula, and ground the servo amplifier, servo motor, etc. securely.

To minimize leakage currents, make the input and output cables as short as possible, and make the grounding cable longer than 30 cm.

$$\text{Rated sensitivity current} \geq 10 \cdot \{I_{g1} + I_{gn} + I_{ga} + K \cdot (I_{g2} \text{ (A-axis)} + I_{gm} \text{ (A-axis)} + I_{g2} \text{ (B-axis)} + I_{gm} \text{ (B-axis)} + I_{g2} \text{ (C-axis)} + I_{gm} \text{ (C-axis)})\} \text{ [mA]} \dots \dots \dots (11.1)$$

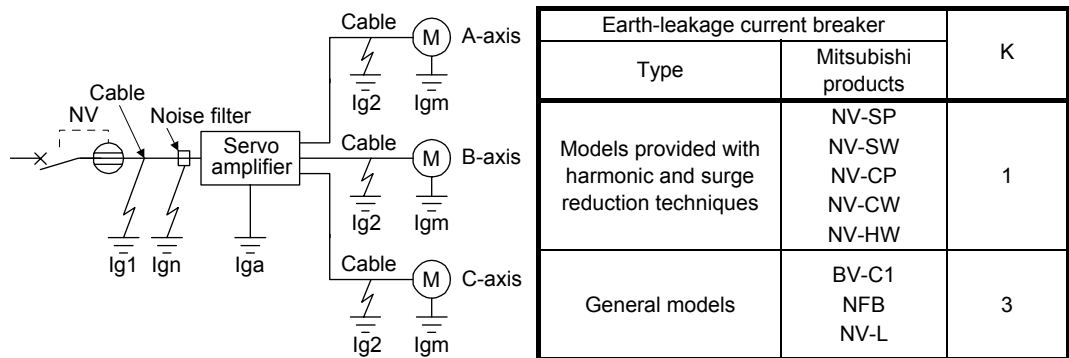

I_{g1} : Leakage current on the electric channel from the earth-leakage current breaker to the input

I_{g2} terminals of the servo amplifier (Found from Fig. 11.1.)

I_{gn} : Leakage current on the electric channel from the output terminals of the servo amplifier to the servo motor (Found from Fig. 11.1.)

I_{gm} : Leakage current when a filter is connected to the input side (4.4 mA per one FR-BIF)

I_{ga} : Leakage current of the servo amplifier (Found from table 11.3.)

I_{gm} : Leakage current of the servo motor (Found from table 11.2.)

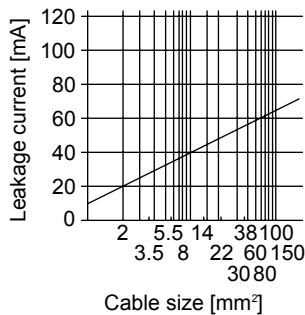

Fig. 11.1 Leakage current example (I_{g1} , I_{g2}) for CV cable run in metal conduit

Table 11.2 Servo motor's leakage current example (I_{gm})

Servo motor power [kW]	Leakage current [mA]
0.05 to 1	0.1

11. OPTIONS AND AUXILIARY EQUIPMENT

Table 11.3 Servo amplifier's leakage current example (Iga)

Servo amplifier	Leakage current [mA]
MR-J4W2-22B MR-J4W2-44B	0.1
MR-J4W2-77B MR-J4W2-1010B MR-J4W3-222B MR-J4W3-444B	0.15

Table 11.4 Earth-leakage current breaker selection example

Servo amplifier	Rated sensitivity current of earth-leakage current breaker [mA]
MR-J4W2-22B MR-J4W2-44B MR-J4W2-77B MR-J4W2-1010B	15
MR-J4W3-222B MR-J4W3-444B	30

11. OPTIONS AND AUXILIARY EQUIPMENT

(2) Selection example

Indicated below is an example of selecting an earth-leakage current breaker under the following conditions.

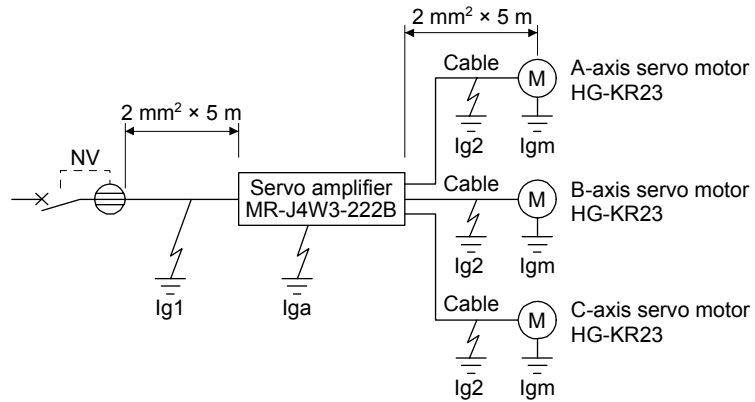

Use an earth-leakage current breaker designed for suppressing harmonics/surges.
Find the terms of equation (11.1) from the diagram.

$$I_{g1} = 20 \cdot \frac{5}{1000} = 0.1 \text{ [mA]}$$

$$I_{g2} = 20 \cdot \frac{5}{1000} = 0.1 \text{ [mA]}$$

$$I_{gn} = 0 \text{ (not used)}$$

$$I_{ga} = 0.15 \text{ [mA]}$$

$$I_{gm} = 0.1 \text{ [mA]}$$

Insert these values in equation (11.1).

$$I_g \geq 10 \cdot \{0.1 + 0 + 0.15 + 1 \cdot (0.1 + 0.1 + 0.1 + 0.1 + 0.1 + 0.1)\} \\ \geq 8.5 \text{ [mA]}$$

According to the result of calculation, use an earth-leakage current breaker having the rated sensitivity current (I_g) of 8.5 mA or more.

An earth-leakage current breaker having I_g of 15 mA is used with the NV-SP/SW/CP/CW/HW series.

11. OPTIONS AND AUXILIARY EQUIPMENT

11.11 EMC filter (recommended)

It is recommended that one of the following filters be used to comply with EN standard's EMC directive. Some EMC filters have large in leakage current.

(1) Combination with the servo amplifier

Servo amplifier	Recommended filter (Soshin Electric)			Mass [kg]	
	Model	Rated current [A]	Rated voltage [VAC]		Leakage current [mA]
MR-J4W2-22B MR-J4W3-222B	(Note) HF3010A-UN	10	250	5	3.5
MR-J4W2-44B	(Note) HF3010A-UN2				
MR-J4W2-77B MR-J4W2-1010B MR-J4W3-444B	(Note) HF3010A-UN	30			5.5

Note. A surge protector is separately required to use any of these EMC filters.

(2) Connection example

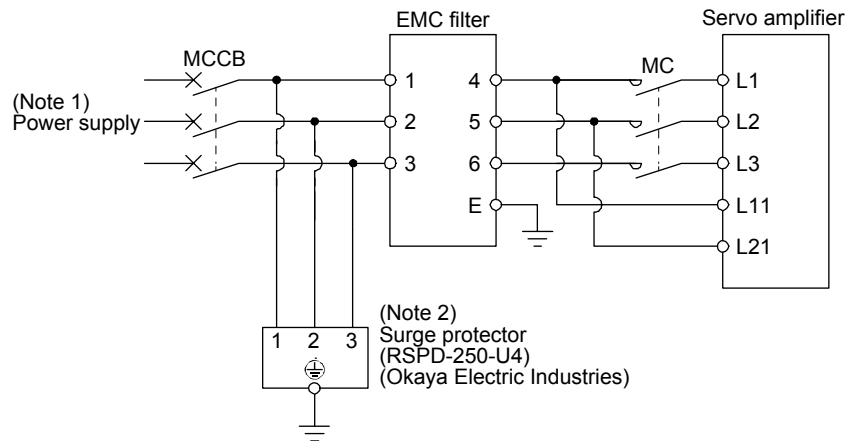

- Note 1. For 1-phase 200 V AC to 240 V AC, connect the power supply to L1 and L3. Leave L2 open. Refer to section 1.3 for the power supply specification.
- Note 2. The example is when a surge protector is connected.

11. OPTIONS AND AUXILIARY EQUIPMENT

- (3) Dimensions
 - (a) EMC filter

HF3010A-UN/HF-3010A-UN2

[Unit: mm]

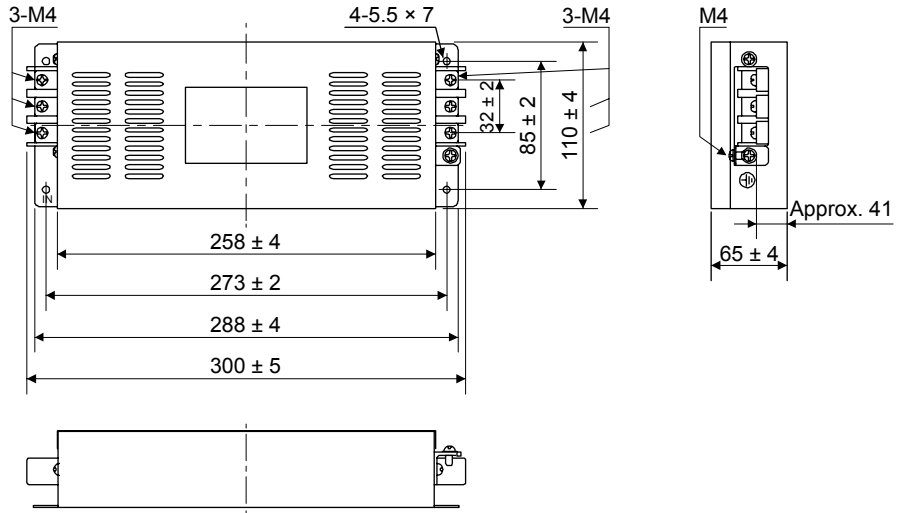

HF3030A-UN

[Unit: mm]

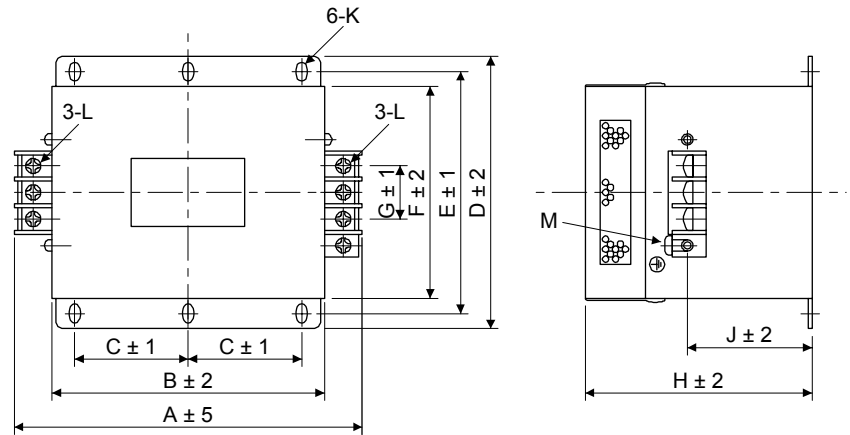

Model	Dimensions [mm]											
	A	B	C	D	E	F	G	H	J	K	L	M
HF3030A-UN	260	210	85	155	140	125	44	140	70	R3.25 length: 8	M5	M4

11. OPTIONS AND AUXILIARY EQUIPMENT

(b) Surge protector

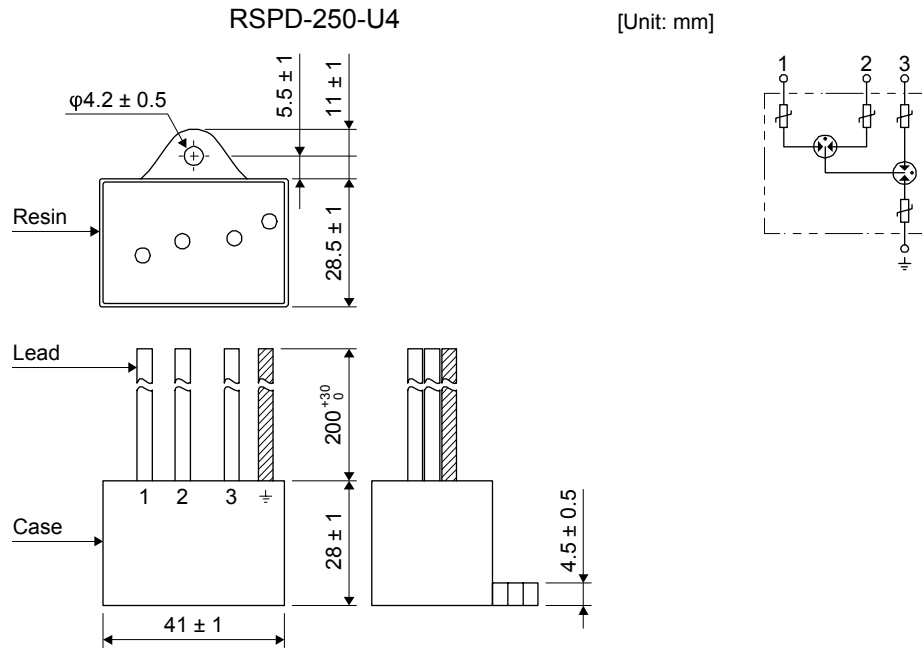

11. OPTIONS AND AUXILIARY EQUIPMENT

11.12 Junction terminal block MR-TB26A

(1) Usage

Always use the junction terminal block (MR-TB26A) with the option cable (MR-TBNATBL_M) as a set. To use a junction terminal block, mount it to the DIN rail.

MR-TBNATBL05M

Cable length
05: 0.5 m
1: 1 m

Terminal numbers on a junction terminal block correspond with the pin numbers on the CN3 connector of a servo amplifier. The terminal symbol S is for the shield.

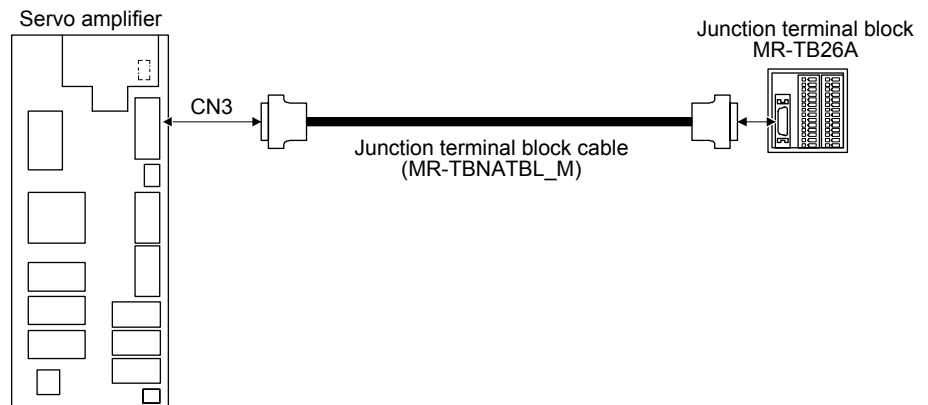

Ground the junction terminal block cable using the S terminal of the junction terminal block.

(2) Specifications

Junction terminal block		MR-TB26A
Item		
Rating		32 V AC/DC 0.5 A
Usable cables	Stranded wire	0.08 mm ² to 1.5mm ² (AWG28 to 14)
	Solid wire	φ0.32 mm to 1.2 mm
	Wire insulator OD	φ3.4 mm or less
Tool		210-619 (WAGO) or equivalent 210-119SB (WAGO) or equivalent
Stripped length		5 mm to 6 mm

11. OPTIONS AND AUXILIARY EQUIPMENT

(3) Dimensions

[Unit: mm]

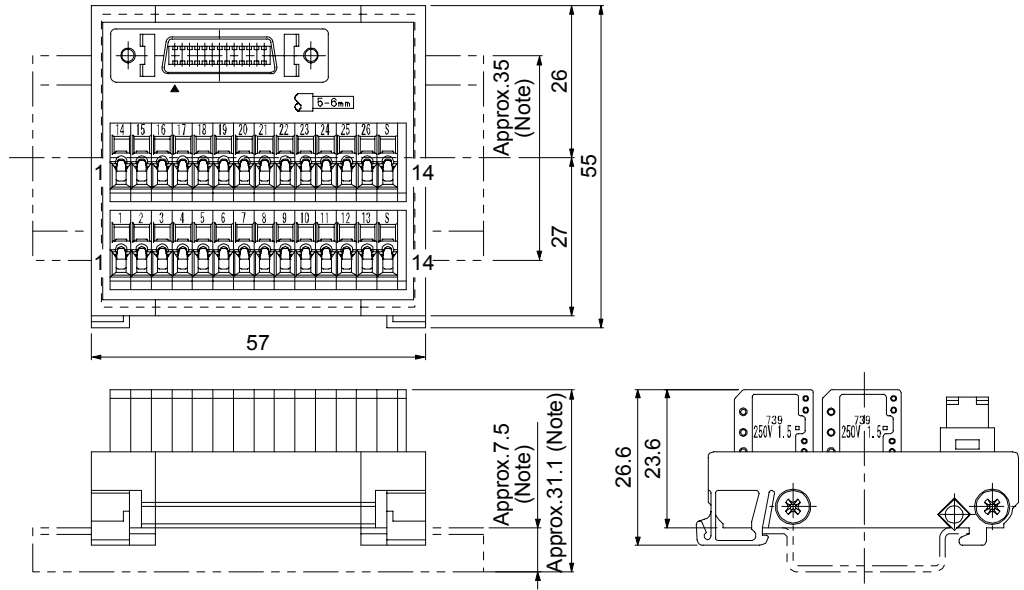

Note. Values in parenthesis are the sizes when installed with a 35 mm DIN rail.

12. ABSOLUTE POSITION DETECTION SYSTEM

12. ABSOLUTE POSITION DETECTION SYSTEM

 CAUTION	<ul style="list-style-type: none"> ● If [AL. 25 Absolute position erased] or [AL. E3 Absolute position counter warning] occur, always perform home position setting again. Otherwise, it may cause an unexpected operation.
	<ul style="list-style-type: none"> ● Refer to appendix 2 and 3 for battery transportation and the new EU Battery Directive.
	<ul style="list-style-type: none"> ● If [AL. 25], [AL. 92], or [AL. 9F] occur due to such as short circuit of the battery, the MR-BAT6V1 battery can become hot. Use the MR-BAT6V1 battery with care to prevent getting burnt.

POINT
<ul style="list-style-type: none"> ● Disconnecting the encoder cable will erase the absolute position data. After disconnecting the encoder cable, always execute home position setting and then positioning operation.

12.1 Features

For normal operation, as shown below, the encoder consists of a detector designed to detect a position within one revolution and a cumulative revolution counter designed to detect the number of revolutions. The absolute position detection system always detects the absolute position of the machine and keeps it battery-backed, independently of whether the servo system controller power is on or off. Therefore, once home position return is made at the time of machine installation, home position return is not needed when power is switched on thereafter.

Even at a power failure or a malfunction, the system can be easily restored.

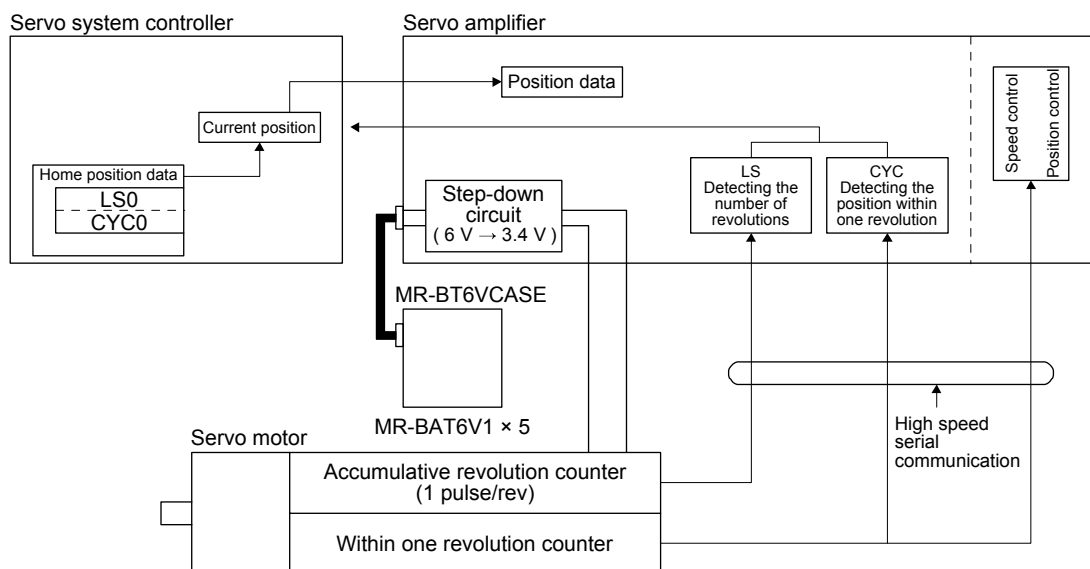

12. ABSOLUTE POSITION DETECTION SYSTEM

12.2 Specifications

WARNING

- Before replacing a battery, turn off the main circuit power and wait for 15 minutes or longer until the charge lamp turns off. Then, check the voltage between P+ and N- with a voltage tester or others. Otherwise, an electric shock may occur. In addition, when confirming whether the charge lamp is off or not, always confirm it from the front of the servo amplifier.

CAUTION

- The internal circuits of the servo amplifier may be damaged by static electricity. Always take the following precautions.
 - Ground human body and work bench.
 - Do not touch the conductive areas, such as connector pins and electrical parts, directly by hand.

POINT

- Before starting battery changing procedure, make sure that the main circuit power is switched off with the control circuit power on. Replacing battery with the control circuit power off will erase the absolute position data.
- Before replacing batteries, check that the new batteries are within battery life.

12. ABSOLUTE POSITION DETECTION SYSTEM

(1) Specification list

Item		Description
System		Electronic battery backup type
Battery unit		MR-BT6VCASE (Install five MR-BAT6V1 batteries.)
Battery	Type	MR-BAT6V1
	Battery pack	2CR17335A (Primary lithium battery)
	Nominal voltage [V]	6
	Nominal capacity [mAh]	1650
	Storage temperature [°C]	0 to 55
	Operating temperature [°C]	0 to 55
	Amount of lithium metal [g]	1.2
	Mercury content	Less than 1 ppm
	Dangerous goods class	Inapplicable to Class 9 (Battery pack containing 2 g or less lithium)
	Operating humidity and storage humidity	90% RH or less (non-condensing)
	Mass [g]	34
Maximum revolution range		Home position ± 32767 rev.
(Note 1) Maximum speed at power failure [r/min]	Rotary servo motor	6000 (This speed applies only when the acceleration time is 0.2 s or more to reach 6,000 r/min.)
	Direct drive motor	500 (This speed applies only when the acceleration time is 0.1 s or more to reach 500 r/min.)
(Note 2) Battery backup time	Rotary servo motor	Approximately 40,000 hours/2 axes, 30,000 hours/3 axes, or 10,000 hours/8 axes (Equipment power supply: off, ambient temperature: 20 °C)
	Direct drive motor	Approximately 10,000 hours/2 axes, 7,000 hours/3 axes, or 2,000 hours/8 axes (Equipment power supply: off, ambient temperature: 20 °C)
(Note 3) Battery life		5 years from date of manufacture

- Note 1. Maximum speed available when the shaft is rotated by external force at the time of power failure or the like. Also, if power is switched on at the servo motor speed of 3000 r/min or higher, position mismatch may occur due to external force or the like.
2. The data-holding time using 5 batteries of MR-BAT6V1 on condition that the power supply of the servo amplifier is off. The battery life varies depending on the number of axes. Replace the batteries within three years since the operation start whether the power supply of the servo amplifier is on/off. If the battery is used out of specification, [AL. 25 Absolute position erased] may occur.
3. Quality of the batteries degrades by the storage condition. The battery life is 5 years from the production date regardless of the connection status.

12. ABSOLUTE POSITION DETECTION SYSTEM

(2) Structure

POINT
● One battery unit can be connected to up to 8 encoders.

(a) When using one servo amplifier

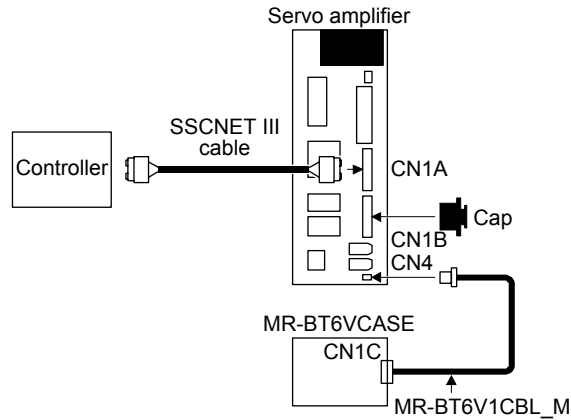

(b) When using up to 8-axis servo amplifiers

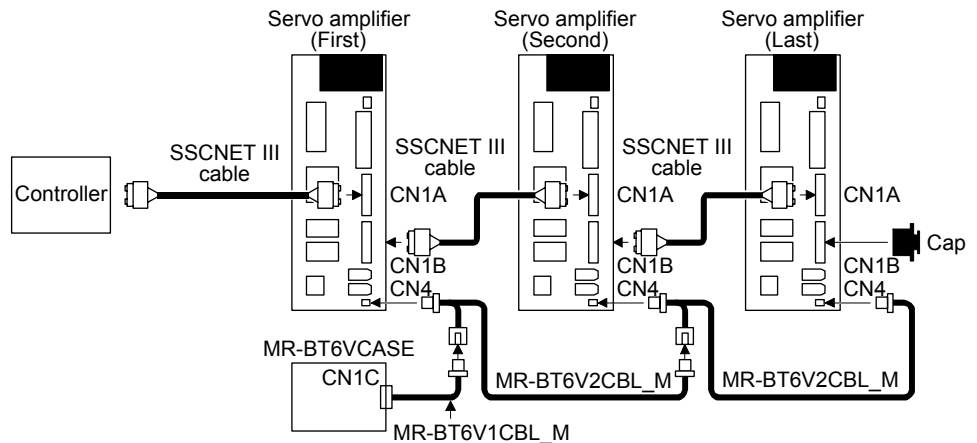

(3) Parameter setting

Set "___ 1" in [Pr. PA03] to enable the absolute position detection system.

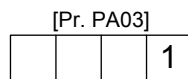

Absolute position detection system selection
 0: Disabled (used in incremental system)
 1: Enabled (used in absolute position detection system)

12. ABSOLUTE POSITION DETECTION SYSTEM

12.3 Assembling a battery unit

	CAUTION	<ul style="list-style-type: none"> ● Do not have new and old batteries installed together. ● When replacing batteries, replace all batteries by new batteries.
---	----------------	--

POINT	<ul style="list-style-type: none"> ● Always install five MR-BAT6V1 batteries to an MR-BT6VCASE battery case.
--------------	---

12.3.1 Required items

Name	Type	Quantity	Remarks
Battery case	MR-BT6VCASE	1	MR-BT6VCASE is a case that holds five MR-BAT6V1 batteries and connect them to the connector.
Battery	MR-BAT6V1	5	Lithium battery (primary battery, nominal +6 V)

12.3.2 Disassembly and assembly of the battery case MR-BT6VCASE

(1) Disassembly of the case

MR-BT6VCASE is shipped assembled. To install MR-BAT6V1s, the case needs to be disassembled.

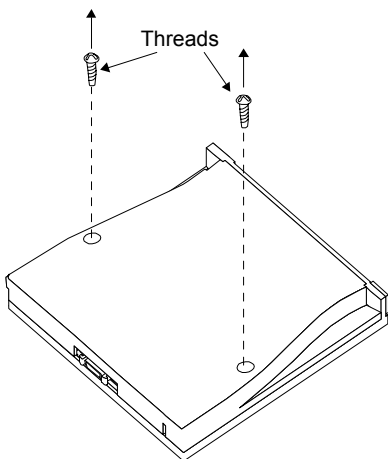

Remove the two screws using a Phillips screwdriver.

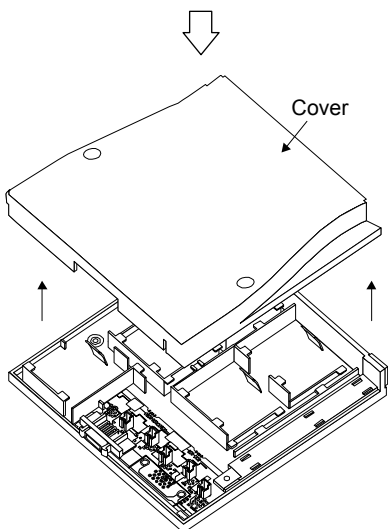

Remove the cover.

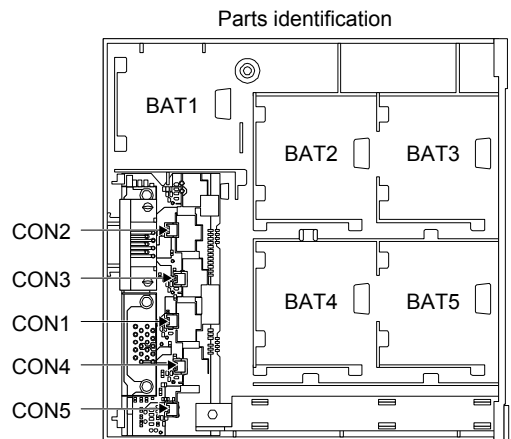

12. ABSOLUTE POSITION DETECTION SYSTEM

(2) Installation of MR-BAT6V1

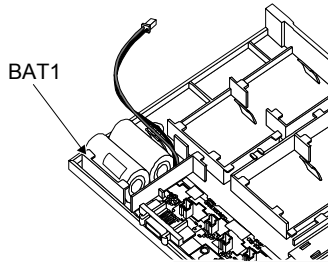

Securely insert MR-BAT6V1 to the BAT1 holder.

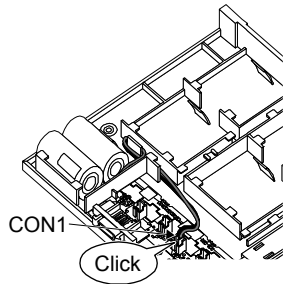

Insert the MR-BAT6V1 connector installed to BAT1 holder 1 to CON1.

Confirm the click sound at this point.

The connector has to be connected in the right direction.

If the connector is pushed forcefully in the wrong direction, the connector will break.

Place the MR-BAT6V1 lead wire to the duct designed to store lead wires.

Insert MR-BAT6V1 to the holder in the same procedure in the order from BAT2 to BAT5.

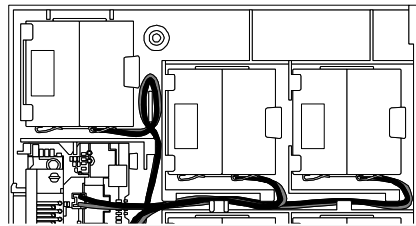

Bring out the lead wire from the space between the ribs, and bend it as shown above to store it in the duct. Connect the lead wire to the connector. Be careful not to get the lead wire caught in the case or other parts.
When the lead wire is damaged, external short circuit may occur, and the battery can become hot.

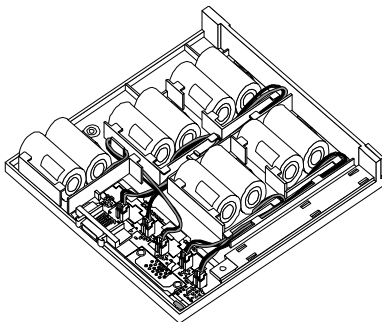

12. ABSOLUTE POSITION DETECTION SYSTEM

(3) Assembly of the case

After all MR-BAT6V1s are installed, fit the cover and insert screws into the two holes and tighten them. Tightening torque is 0.71 N·m.

POINT

- When assembling the case, be careful not to get the lead wires caught in the fitting parts or the screwing parts.

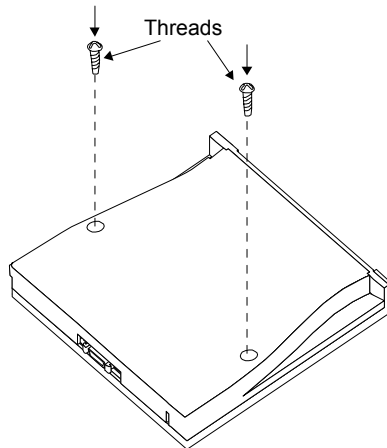

(4) Precautions for removal of battery

The connector attached to the MR-BAT6V1 battery has the lock release lever. When removing the connector, pull out the connector while pressing the lock release lever.

12.3.3 Battery cable removal



CAUTION

- Pulling out the connector of the MR-BT6V1CBL and the MR-BT6V2CBL without the lock release lever pressed may damage the CN4 connector of the servo amplifier or the connector of the MR-BT6V1CBL or MR-BT6V2CBL.

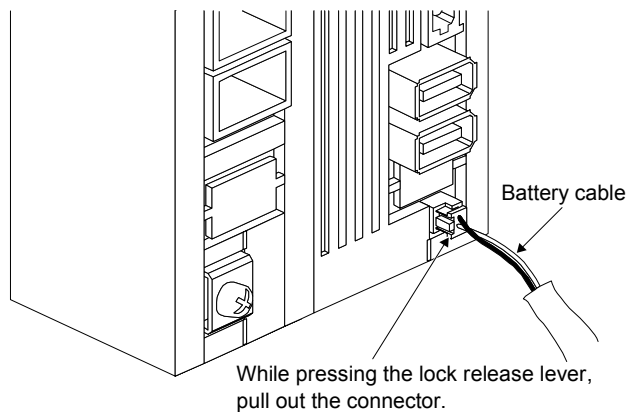

12. ABSOLUTE POSITION DETECTION SYSTEM

12.4 Confirmation of absolute position detection data

You can check the absolute position data with MR Configurator2.

Choose "Monitor" and "ABS Data Display" to open the absolute position data display screen.

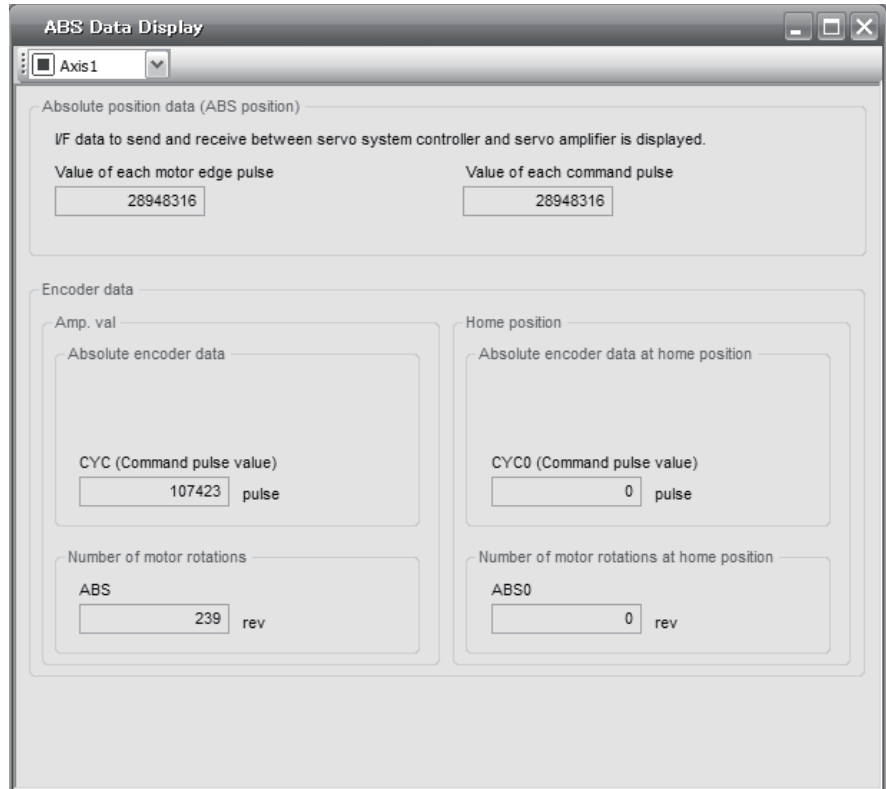

13. USING STO FUNCTION

13. USING STO FUNCTION

POINT
● In the case of STO function of this servo amplifier, energies to servo motor are interrupted in all axes at the same time.
● In the torque control mode, the forced stop deceleration function is not available.

13.1 Introduction

This section provides the cautions of the STO function.

13.1.1 Summary

This servo amplifier complies with the following safety standards.

- ISO/EN ISO 13849-1 category 3 PL d
- IEC/EN 61508 SIL 2
- IEC/EN 61800-5-2 SIL 2

13.1.2 Terms related to safety

The STO function shuts down energy to servo motors, thus removing torque. This function electronically cuts off power supply in the servo amplifier.

The purpose of this safety function is as follows.

- (1) Uncontrolled stop according to stop category 0 of IEC/EN 60204-1
- (2) Preventing unexpected start-up

13.1.3 Cautions

The following basic safety notes must be read carefully and fully in order to prevent injury to persons or damage to property.

Only qualified personnel are authorized to install, start-up, repair, or service the machines in which these components are installed.

They must be familiar with all applicable local regulations and laws in which machines with these components are installed, particularly the standards mentioned in this manual.

The staff responsible for this work must be given express permission from the company to perform start-up, programming, configuration, and maintenance of the machine in accordance with the safety standards.

 WARNING	● Improper installation of the safety related components or systems may cause improper operation in which safety is not assured, and may result in severe injuries or even death.
--	---

Protective Measures

- This servo amplifier satisfies the Safe Torque Off (STO) function described in IEC/EN 61800-5-2 by preventing the energy supply from the servo amplifier to the servo motor. If an external force acts upon the drive axis, additional safety measures, such as brakes or counterbalances must be used.

13. USING STO FUNCTION

13.1.4 Residual risks of the STO function

Machine manufacturers are responsible for all risk evaluations and all associated residual risks. Below are residual risks associated with the STO function. Mitsubishi is not liable for any damages or injuries caused by these risks.

- (1) The STO function disables energy supply to the servo motor by electrical shut-off. The function does not mechanically disconnect electricity from the motor. Therefore, it cannot prevent exposure to electric shock. To prevent an electric shock, install a magnetic contactor or a molded-case circuit breaker to the main circuit power supply (L1, L2, and L3) of the servo amplifier.
- (2) The STO function disables energy supply to the servo motor by electrical shut-off. It does not guarantee the stop control or the deceleration control of the servo motor.
- (3) For proper installation, wiring, and adjustment, thoroughly read the manual of each individual safety related component.
- (4) In the safety circuit, use components that are confirmed safe or meet the required safety standards.
- (5) The STO function does not guarantee that the drive part of the servo motor will not rotate due to external or other forces.
- (6) Safety is not assured until safety-related components of the system are completely installed or adjusted.
- (7) When replacing this servo amplifier, confirm that the model name of servo amplifiers are exactly the same as those being replaced. Once installed, make sure to verify the performance of the safety functions before commissioning the system.
- (8) Perform all risk assessments to the machine or the whole system.
- (9) To prevent accumulation of malfunctions, perform malfunction checks at regular intervals based on the risk assessments of the machine or the system. Regardless of the system safety level, malfunction checks should be performed at least once per year.
- (10) If the upper and lower power module in the servo amplifier are shorted and damaged simultaneously, the servo motor may make a half revolution at a maximum. For a linear servo motor, the primary side will move a distance of pole pitch.
- (11) The STO input signals (STO1 and STO2) must be supplied from one power source. Otherwise, the STO function may not function properly due to a sneak current, failing to bring the STO shut-off state.
- (12) For the STO I/O signals of the STO function, supply power by using a safety extra low voltage (SELV) power supply with the reinforced insulation.

13. USING STO FUNCTION

13.1.5 Specifications

(1) Specifications

Item	Specifications
Safety function	STO (IEC/EN 61800-5-2)
Safety performance (Certification standards)	EN ISO 13849-1 category 3 PL d, EN 61508 SIL 2, EN 62061 SIL CL2, EN 61800-5-2 SIL 2
Mean time to dangerous failure (MTTFd)	100 years or more (Note)
Diagnostic converge (DC)	Medium (90% to 99%) (Note)
Average probability of dangerous failures per hour (PFH) [1/h]	1.68×10^{-10}
Number of on/off times of STO	1,000,000 times
CE marking	LVD: EN 61800-5-1 EMC: EN 61800-3 MD: EN ISO 13849-1, EN 61800-5-2, EN 62061

Note. This is the value required by safety standards.

(2) Function block diagram (STO function)

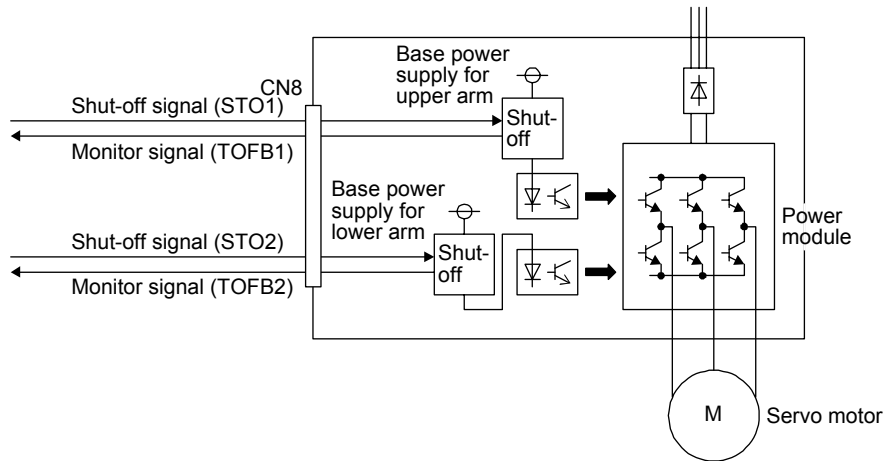

(3) Operation sequence (STO function)

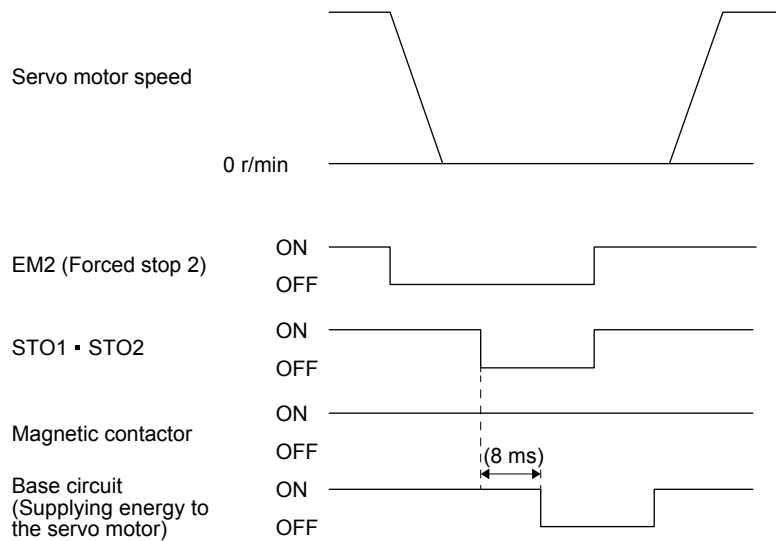

13. USING STO FUNCTION

13.1.6 Maintenance

This servo amplifier has alarms and warnings for maintenance that supports the Mitsubishi drive safety function. (Refer to chapter 8.)

13.2 STO I/O signal connector (CN8) and signal layouts

13.2.1 Signal layouts

POINT
● The pin configurations of the connectors are as viewed from the cable connector wiring section.

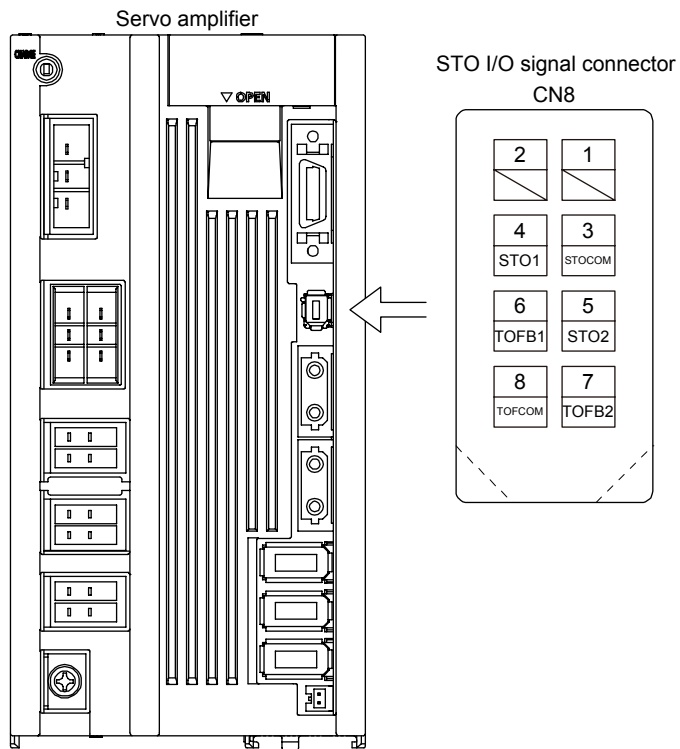

13. USING STO FUNCTION

13.2.2 Signal (device) explanations

(1) I/O device

Signal name	Connector pin No.	Description	I/O division
STOCOM	CN8-3	Common terminal for input signal of STO1 and STO2	DI-1
STO1	CN8-4	Inputs STO state 1. STO state (base shut-off): Open between STO1 and STOCOM. STO release state (in driving): Close between STO1 and STOCOM. Be sure to turn off STO1 after the servo motor stops by the servo-off state or with forced stop deceleration by turning off EM2 (Forced stop 2).	DI-1
STO2	CN8-5	Inputs STO state 2. STO state (base shut-off): Open between STO2 and STOCOM. STO release state (in driving): Close between STO2 and STOCOM. Be sure to turn off STO2 after the servo motor stops by the servo-off state or with forced stop deceleration by turning off EM2 (Forced stop 2).	DI-1
TOFCOM	CN8-8	Common terminal for monitor output signal in STO state	DO-1
TOFB1	CN8-6	Monitor output signal in STO1 state STO state (base shut-off): Between TOFB1 and TOFCOM is closed. STO release state (in driving): Between TOFB1 and TOFCOM is opened.	DO-1
TOFB2	CN8-7	Monitor output signal in STO2 state STO state (base shut-off): Between TOFB2 and TOFCOM is closed. STO release state (in driving): Between TOFB2 and TOFCOM is opened.	DO-1

(2) Signals and STO state

The following table shows the TOFB and STO states when the power is on in normal state and STO1 and STO2 are on (closed) or off (opened).

Input signal		State		
STO1	STO2	Between TOFB1 and TOFCOM (Monitoring STO1 state)	Between TOFB2 and TOFCOM (Monitoring STO2 state)	Between TOFB1 and TOFB2 (Monitoring STO state of servo amplifier)
Off	Off	On: STO state (base circuit shut-off)	On: STO state (base circuit shut-off)	On: STO state (base circuit shut-off)
Off	On	On: STO state (base circuit shut-off)	Off: STO release state	Off: STO state (base circuit shut-off)
On	Off	Off: STO release state	On: STO state (base circuit shut-off)	Off: STO state (base circuit shut-off)
On	On	Off: STO release state	Off: STO release state	Off: STO release state

(3) Test pulse of STO input signal

Set the test pulse off time inputted from outside to 1 ms or less.

13.2.3 How to pull out the STO cable

The following shows how to pull out the STO cable from the CN8 connector of the servo amplifier.

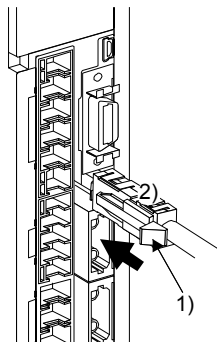

While pressing knob 1) of the STO cable plug in the direction of the arrow, pull out the plug 2).

(This figure shows the MR-J4-B servo amplifier. This procedure also applies to the MR-J4W-B servo amplifier.)

13. USING STO FUNCTION

13.3 Connection example

POINT	
●	Turn off STO (STO1 and STO2) after the servo motor stops by the servo off state or with forced stop deceleration by turning off EM2 (Forced stop 2). Configure an external sequence that has the timings shown as below using an external device such as the MR-J3-D05 safety logic unit.

The diagram shows three waveforms over time. The top waveform, labeled 'STO1 · STO2', is ON and then turns OFF at a certain point. The middle waveform, labeled 'EM2', is ON and then turns OFF at the same point. The bottom waveform, labeled 'Servo motor speed', shows a ramp down from an initial speed to 0 r/min. A vertical dashed line marks the time when the speed reaches 0 r/min, which is when the STO and EM2 signals turn OFF.

●	If STO is turned off during operation, the servo motor is in dynamic brake stop (stop category 0), and [AL.63 STO timing error] will occur.
---	---

13.3.1 Connection example for CN8 connector

This servo amplifier is equipped with the connector (CN8) in accordance with the STO function. When this connector is used with a certified external safety relay, power to the motor can be safely removed and unexpected restart can be prevented. The safety relay used should meet the applicable safety standards and have forcibly guided or mirror contacts for the purpose of error detection.

In addition, the MR-J3-D05 safety logic unit can be used instead of a safety relay for implementation of various safety standards. Refer to Appendix 5 for details.

The following diagram is for source interface. For sink interface, refer to section 13.4.1.

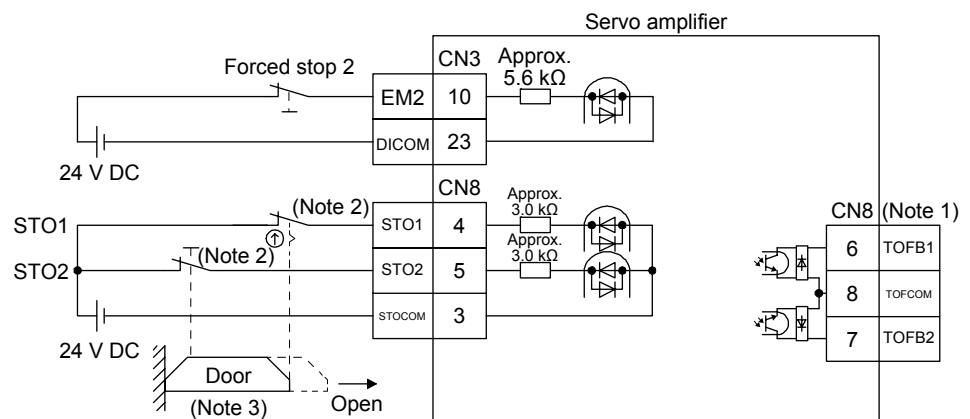

- Note 1. By using TOFB, whether the servo is in the STO state can be confirmed. For connection examples, refer to section 13.3.2 to 13.3.4.
- Note 2. When using the STO function, turn off STO1 and STO2 at the same time. Turn off STO1 and STO2 after the servo motor stops by the servo off state or with forced stop deceleration by turning off EM2 (Forced stop 2).
- Note 3. Configure the interlock circuit so that the door is open after the servo motor is stopped.

13. USING STO FUNCTION

13.3.2 External I/O signal connection example using an MR-J3-D05 safety logic unit

POINT

● This connection is for source interface. For the other I/O signals, refer to the connection examples in section 3.2.2.

(1) Connection example

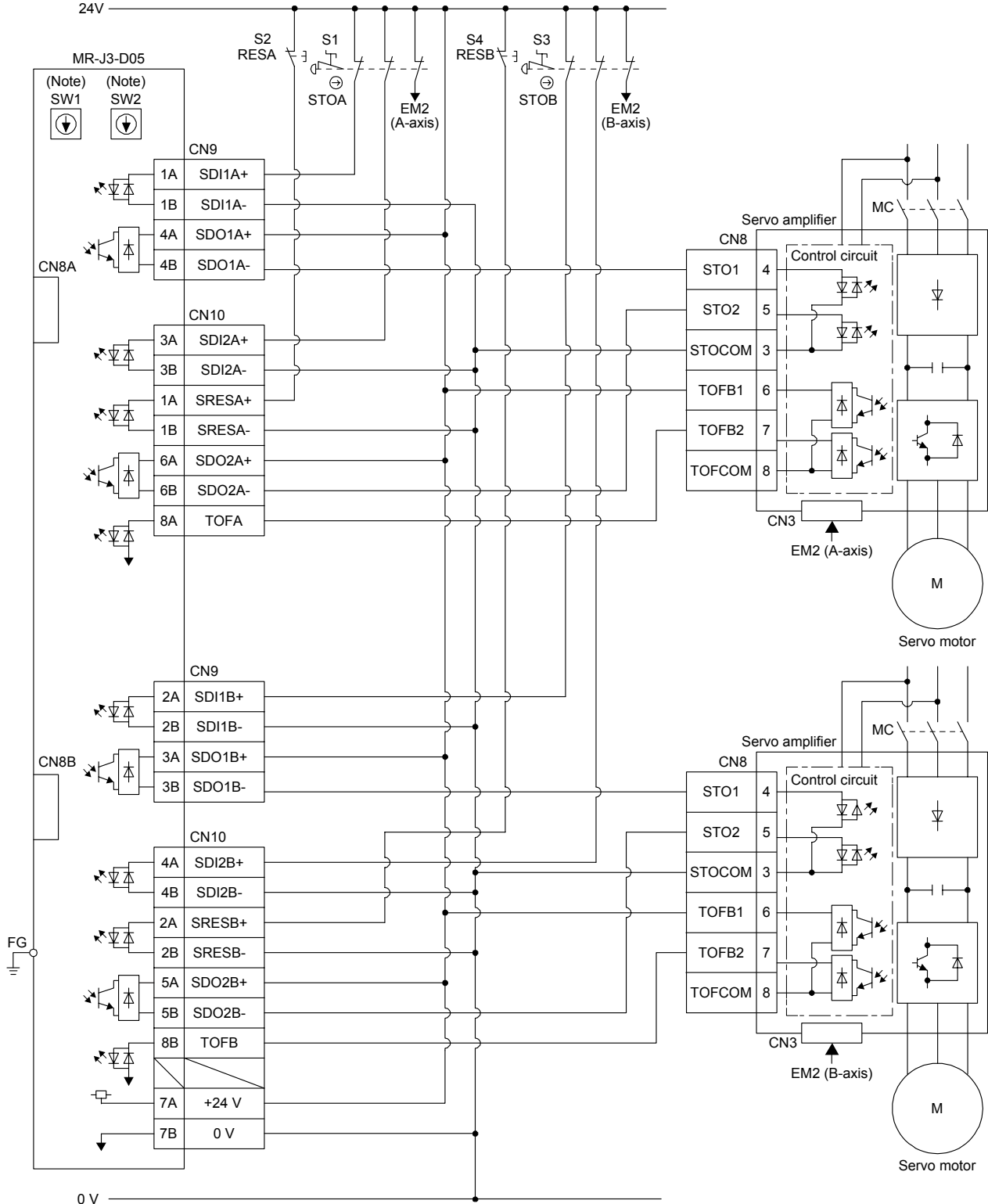

Note. Set the delay time of STO output with SW1 and SW2. These switches are located where denoted from the front panel.

13. USING STO FUNCTION

(2) Basic operation example

The switch status of STOA is input to SDI2A+ of MR-J3-D05, and then it will be input to STO1 and STO2 of the servo amplifier via SDO1A and SDO2A of MR-J3-D05.

The switch status of STOB is input to SDI2B+ of MR-J3-D05, and then it will be input to STO1 and STO2 of the servo amplifier via SDO1B and SDO2B of MR-J3-D05.

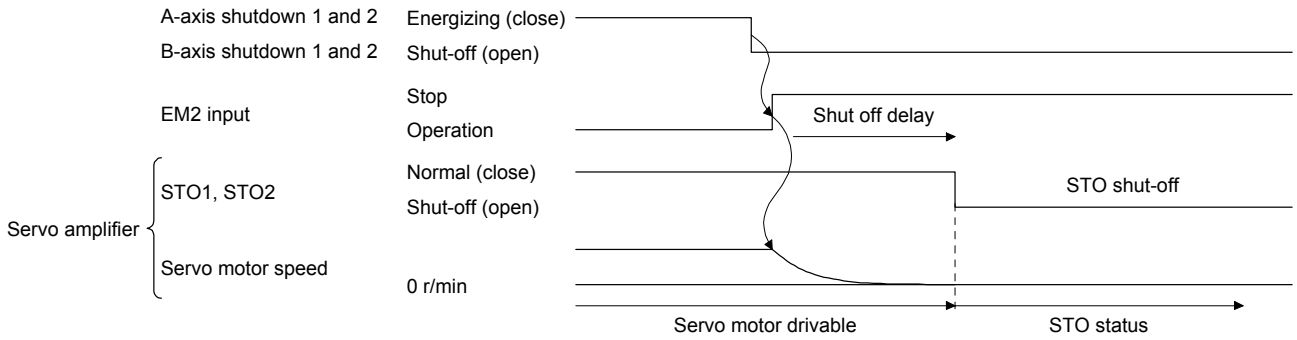

13. USING STO FUNCTION

13.3.3 External I/O signal connection example using an external safety relay unit

POINT
<ul style="list-style-type: none"> ● This connection is for source interface. For the other I/O signals, refer to the connection examples in section 3.2.2.

This connection example complies with the requirement of ISO/EN ISO 13849-1 category 3 PL d. For details, refer to the safety relay module user's manual.

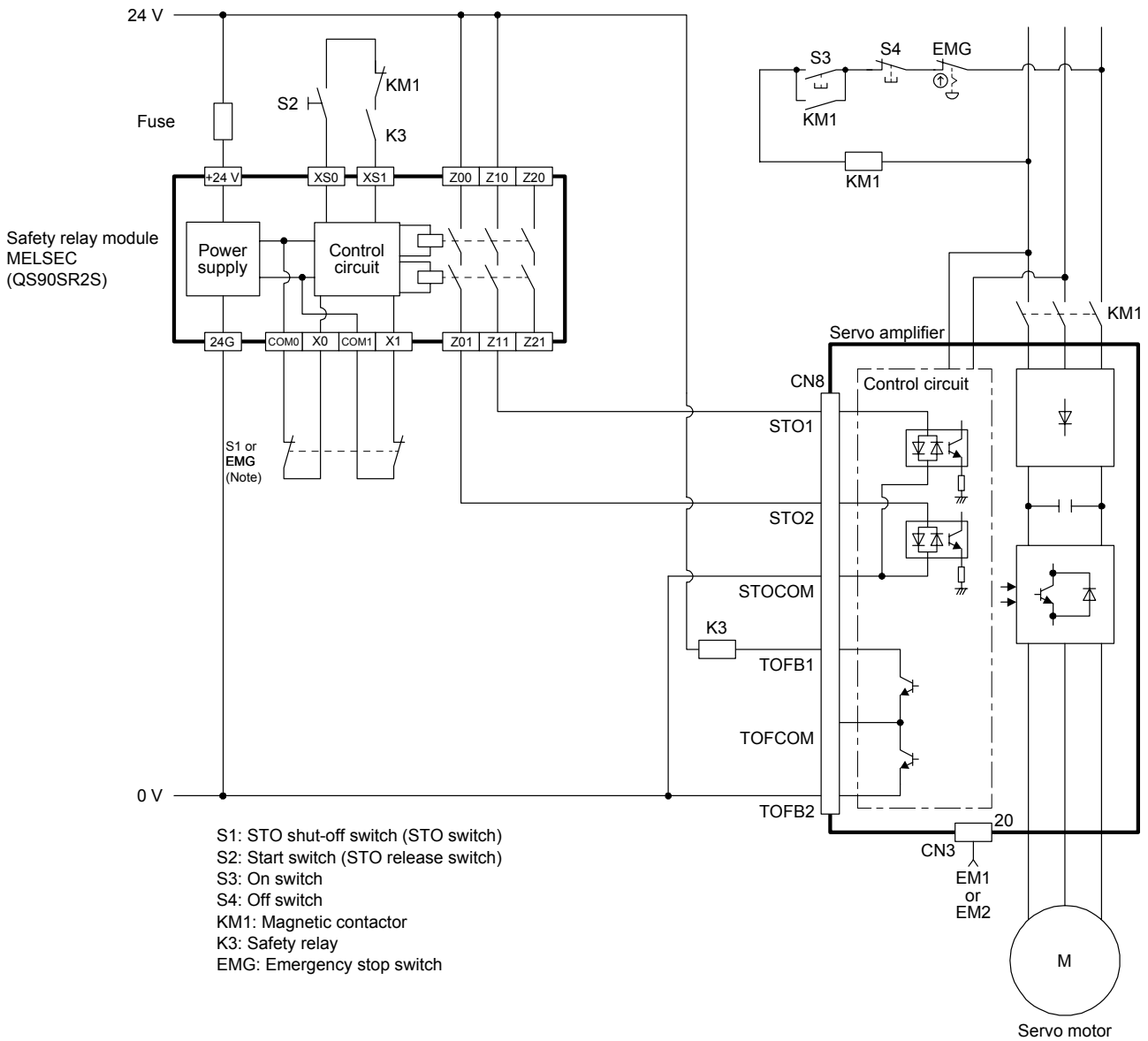

Note. To enable the STO function of the servo amplifier by using "Emergency switching off", change S1 to EMG. The stop category at this time is "0". If STO is turned off while the servo motor is rotating, [AL. 63 STO timing error] will occur.

13. USING STO FUNCTION

13.3.4 External I/O signal connection example using a motion controller

POINT
<ul style="list-style-type: none"> ● This connection is for source interface. For the other I/O signals, refer to the connection examples in section 3.2.2. ● For MC-Y0B and PC-Y0B, design a ladder program to output MC-Y0B and PC-Y0B after the servo motor stops.

This connection diagram is an example of STO circuit configured with a servo amplifier and motion controller. Use the switch that complies with the requirement of ISO/EN ISO 13849-1 category 3 PL d as an emergency stop switch. This connection example complies with the requirement of ISO/EN ISO 13849-1 category 3 PL d. The following shows an example of I/O (X and Y) signal assignment of the motion controller safety signal module. For details, refer to the motion controller user's manual.

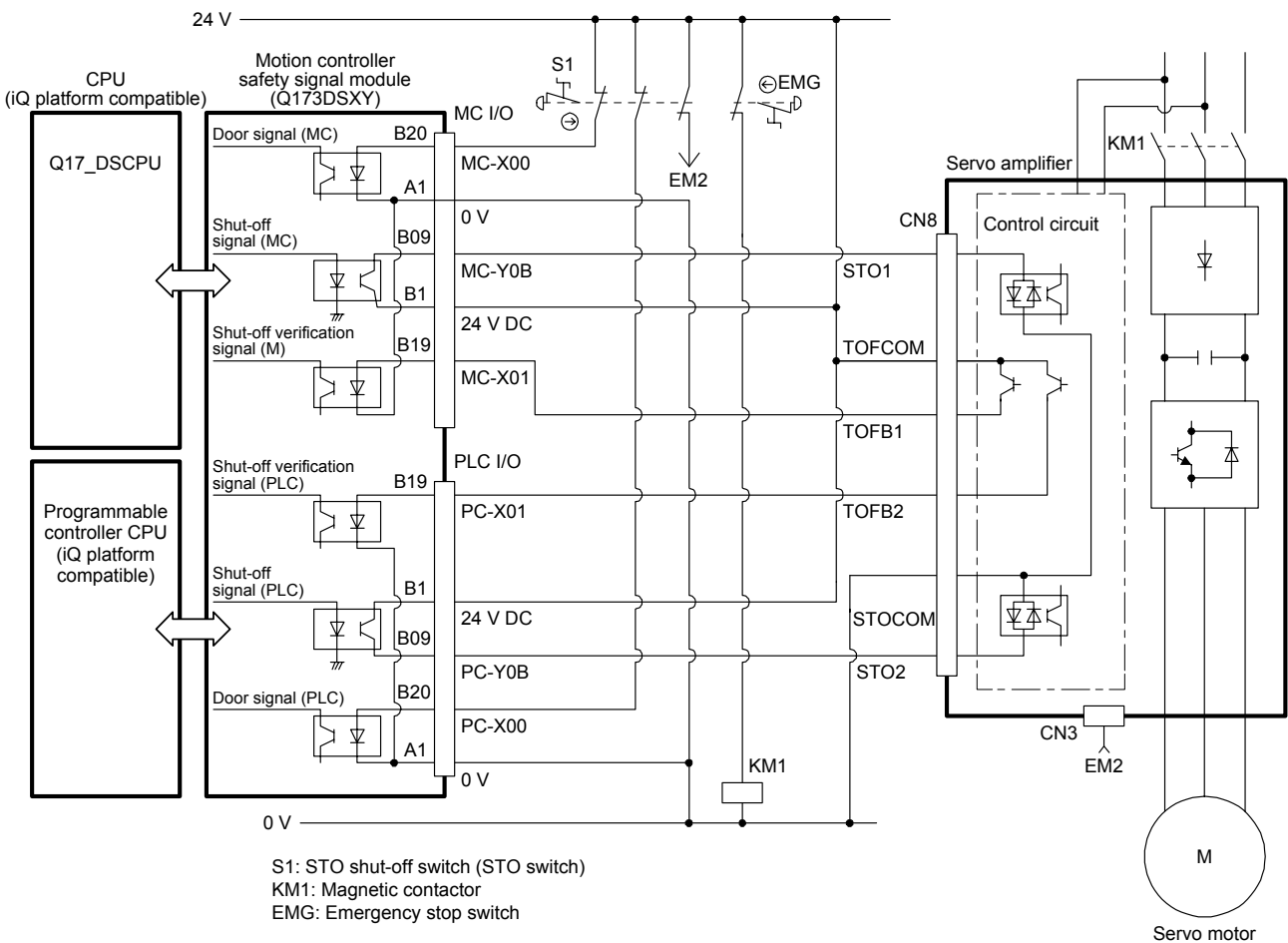

13. USING STO FUNCTION

13.4 Detailed description of interfaces

This section provides the details of the I/O signal interfaces (refer to the I/O division in the table) given in section 13.2. Refer to this section and make connection with the external device.

13.4.1 Sink I/O interface

(1) Digital input interface DI-1

This is an input circuit whose photocoupler cathode side is input terminal. Transmit signals from sink (open-collector) type transistor output, relay switch, etc.

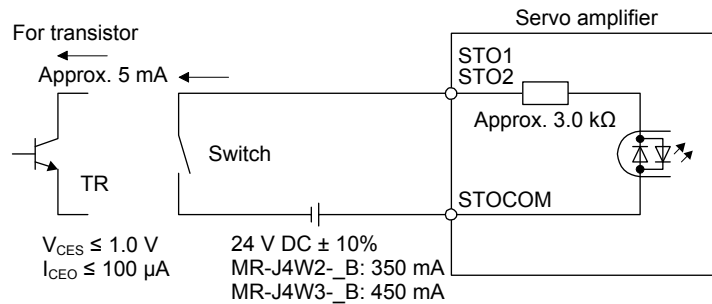

(2) Digital output interface DO-1

This is a circuit of collector output terminal of the output transistor. When the output transistor is turned on, collector terminal current will be applied for the output.

A lamp, relay or photocoupler can be driven. Install a diode (D) for an inductive load, or install an inrush current suppressing resistor (R) for a lamp load.

(Rated current: 40 mA or less, maximum current: 50 mA or less, inrush current: 100 mA or less) A maximum of 5.2 V voltage drop occurs in the servo amplifier.

(a) When outputting two STO states by using each TOFB

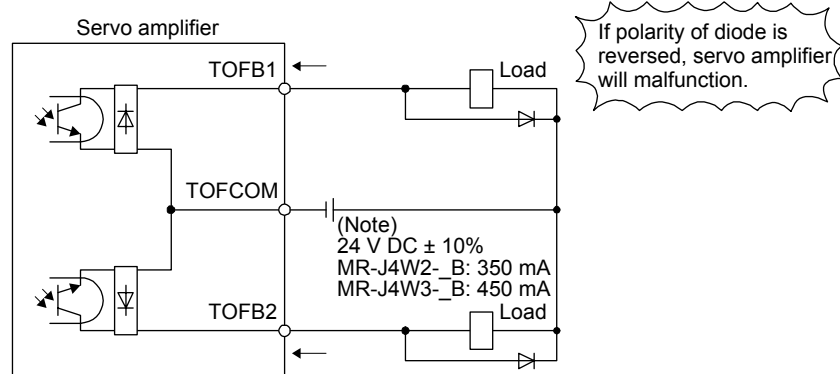

Note. If the voltage drop (maximum of 2.6 V) interferes with the relay operation, apply high voltage (maximum of 26.4 V) from external source.

13. USING STO FUNCTION

(b) When outputting two STO states by using one TOFB

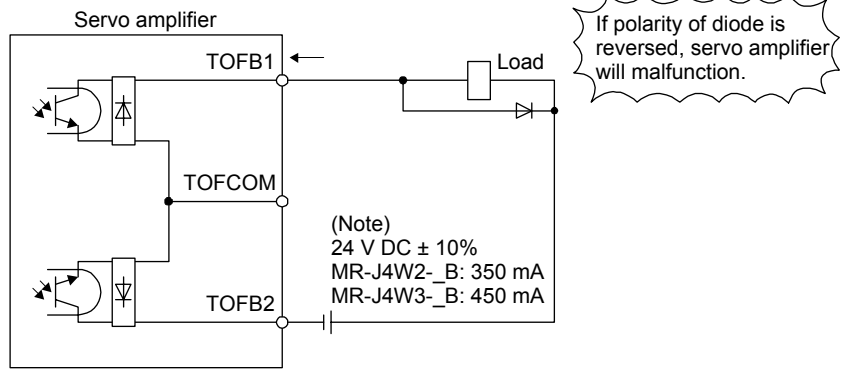

Note. If the voltage drop (maximum of 5.2 V) interferes with the relay operation, apply high voltage (maximum of 26.4 V) from external source.

13.4.2 Source I/O interface

In this servo amplifier, source type I/O interfaces can be used.

(1) Digital input interface DI-1

This is an input circuit whose photocoupler anode side is input terminal. Transmit signals from source (open-collector) type transistor output, relay switch, etc.

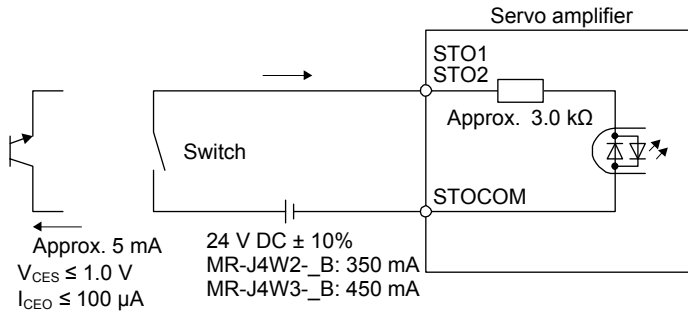

13. USING STO FUNCTION

(2) Digital output interface DO-1

This is a circuit of emitter output terminal of the output transistor. When the output transistor is turned on, current will be applied from the output to a load.

A maximum of 5.2 V voltage drop occurs in the servo amplifier.

(a) When outputting two STO states by using each TOFB

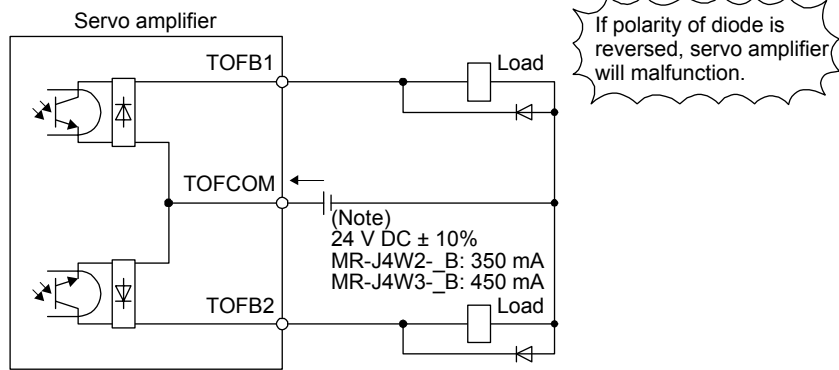

Note. If the voltage drop (maximum of 2.6 V) interferes with the relay operation, apply high voltage (maximum of 26.4 V) from external source.

(b) When outputting two STO states by using one TOFB

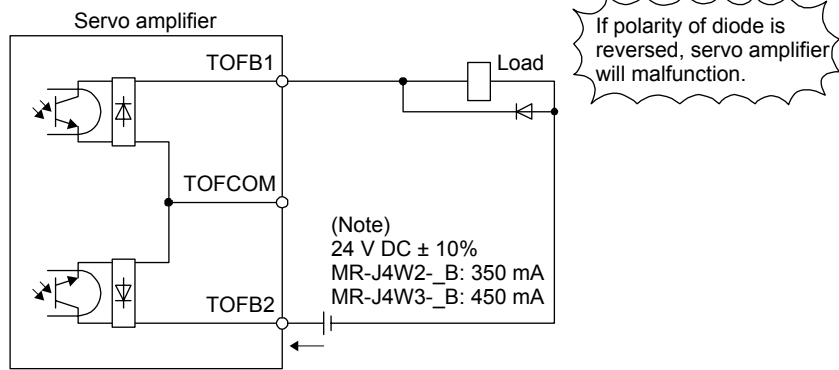

Note. If the voltage drop (maximum of 5.2 V) interferes with the relay operation, apply high voltage (maximum of 26.4 V) from external source.

14. USING A LINEAR SERVO MOTOR

14. USING A LINEAR SERVO MOTOR

⚠ WARNING ● When using the linear servo motor, read the "Linear Servo Motor Instruction Manual" and the "Linear Encoder Instruction Manual".

14.1 Functions and configuration

14.1.1 Summary

The fields of semiconductor/LCD manufacturing systems, mounters, and others have strong demands for high accuracy, high speed, and efficiency. Therefore, the number of systems using a linear servo motor for a drive axis has been increasing. Since the linear servo system can obtain the characteristics of the high speed and the high acceleration/deceleration greater than the ball screw drive system. The linear servo system also does not have a ball screw wear which is a weak point in the ball screw drive system. This will extend the life of the equipment. In addition, since a response error due to backlash and friction does not occur, you can establish a high-accuracy system.

The following shows the differences between the linear servo motor and the rotary servo motor.

Category	Item	Differences		Remarks	
		Linear servo motor	Rotary servo motor		
External I/O signal	FLS (Upper stroke limit), RLS (Lower stroke limit)	Required (for magnetic pole detection)	Not required	Automatically turns on in the parameter setting.	
Motor pole adjustment	Magnetic pole detection	Required	Not required (default setting)	Automatically executed at the first servo-on after the power is turned on. For the absolute position linear encoder, [Pr. PL01] can disable the magnetic pole detection. The timing of the magnetic pole detection can be changed with [Pr. PL01]. (Refer to (3) (a) of section 14.3.2.)	
Home position return	Reference home position	1048576 pulses unit (initial value)	One servo motor revolution unit	Home position return pitch can be changed with parameter setting. (Refer to section 14.3.3)	
Absolute position detection system	Absolute position encoder battery (1 battery case (MR-BT6VCASE) and 5 batteries (MR-BAT6V1))	Not required	Required	The following alarms and warnings are not provided for the linear servo motor. <ul style="list-style-type: none"> ▪ [AL. 25 Absolute position erased] ▪ [AL. 92 Battery cable disconnection warning] ▪ [AL. 9F Battery warning] ▪ [AL. E3 Absolute position counter warning] 	
Auto tuning	Load to motor inertia ratio (J)	Load to motor mass ratio	Load to motor inertia ratio		
MR Configurator2 (SW1DNC-MRC2-J) (Software version 1.10L or later)	Motor speed (Data display and setting)	mm/s unit	r/min unit		
	Test operation function	Positioning operation	Supported	Supported	
		Motor-less operation	None	Supported	
		JOG operation	None	Supported	
		Program operation	Supported	Supported	

14. USING A LINEAR SERVO MOTOR

14.1.2 Servo system with auxiliary equipment

CAUTION ●Connecting a linear servo motor for different axis to the CNP3A, CNP3B, or CNP3C connector may cause a malfunction.

POINT

- Equipment other than the servo amplifier and linear servo motor are optional or recommended products.
- When using the linear servo motor, set [Pr. PA01] to " _ _ 4 _".

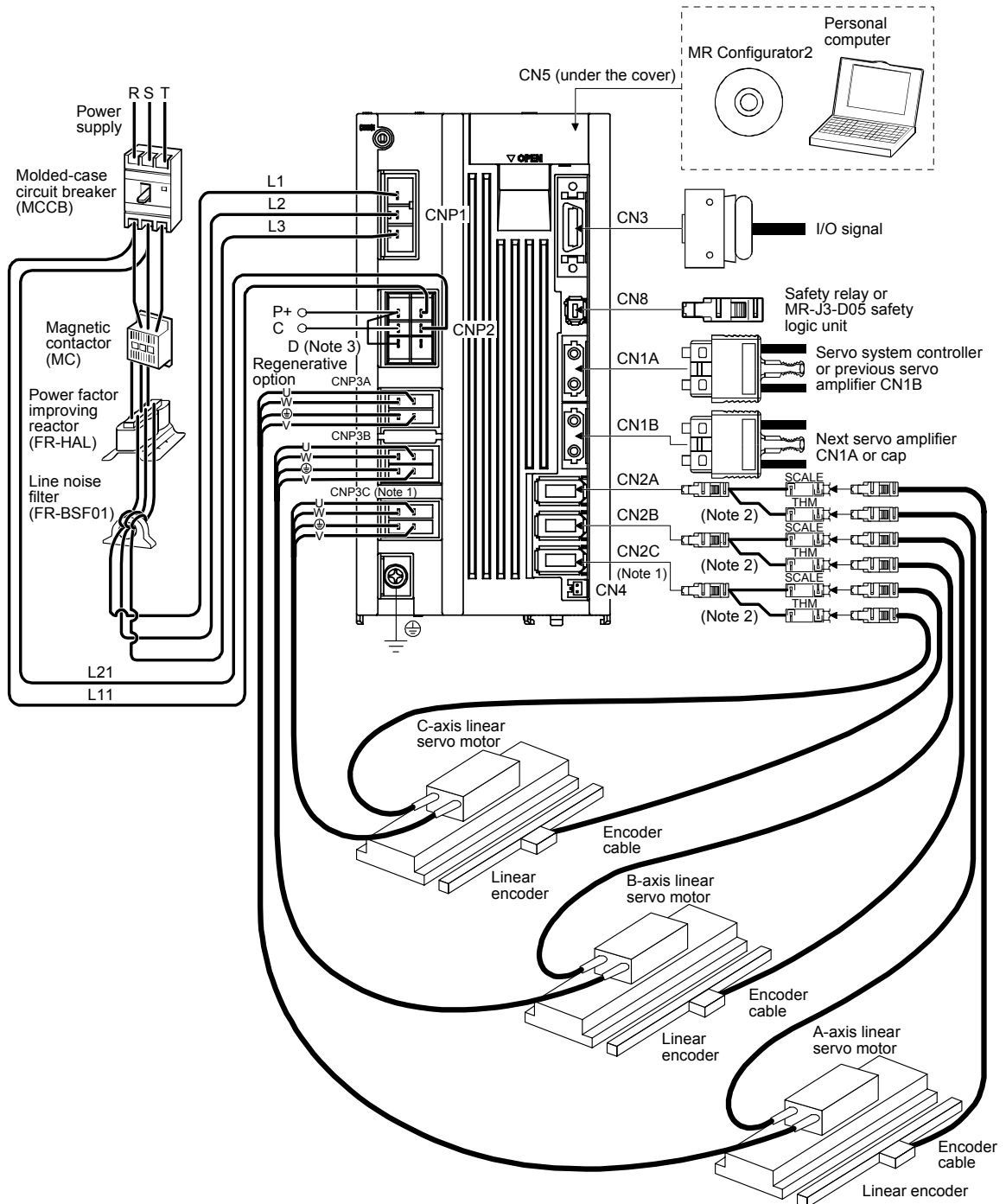

14. USING A LINEAR SERVO MOTOR

- Note
1. This figure shows the 3-axis servo amplifier.
 2. For the branch cable, use the MR-J4THCBL03M (optional).
 3. Always connect between P+ and D terminals. When using the regenerative option, refer to section 11.2.

14.2 Signals and wiring

! WARNING

- Any person who is involved in wiring should be fully competent to do the work.
- Before wiring, turn off the power and wait for 15 minutes or more until the charge lamp turns off. Then, confirm that the voltage between P+ and N- is safe with a voltage tester and others. Otherwise, an electric shock may occur. In addition, when confirming whether the charge lamp is off or not, always confirm it from the front of the servo amplifier.
- Ground the servo amplifier and the linear servo motor securely.
- Do not attempt to wire the servo amplifier and the linear servo motor until they have been installed. Otherwise, it may cause an electric shock.
- The cables should not be damaged, stressed, loaded, or pinched. Otherwise, it may cause an electric shock.
- To avoid an electric shock, insulate the connections of the power supply terminals.

! CAUTION

- Wire the equipment correctly and securely. Otherwise, the linear servo motor may operate unexpectedly, resulting in injury.
- Connect cables to the correct terminals. Otherwise, a burst, damage, etc. may occur.
- Ensure that polarity (+/-) is correct. Otherwise, a burst, damage, etc. may occur.
- The surge absorbing diode installed to the DC relay for control output should be fitted in the specified direction. Otherwise, the emergency stop and other protective circuits may not operate.

For sink output interface

For source output interface

- Use a noise filter, etc. to minimize the influence of electromagnetic interference. Electromagnetic interference may be given to the electronic equipment used near the servo amplifier.
- Do not install a power capacitor, surge killer or radio noise filter (FR-BIF option) with the power wire of the linear servo motor.
- When using the regenerative resistor, switch power off with the alarm signal. Otherwise, a transistor fault or the like may overheat the regenerative resistor, causing a fire.

14. USING A LINEAR SERVO MOTOR

- Connect the servo amplifier power output (U, V, and W) to the linear servo motor power input (U, V, and W) directly. Do not let a magnetic contactor, etc. intervene. Otherwise, it may cause a malfunction.

CAUTION

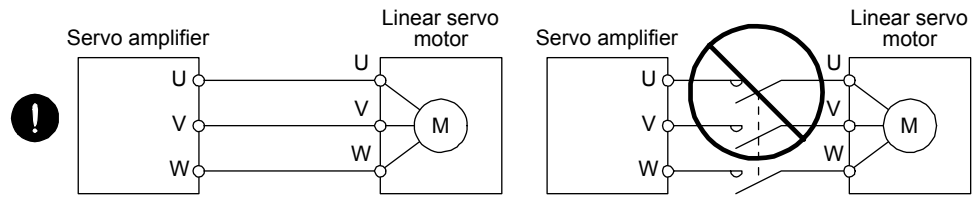

- Do not modify the equipment.
- The cables such as power wires deriving from the primary side cannot stand the long-term bending action. Avoid the bending action by fixing the cables to the moving part, etc. Also, use the cable that stands the long-term bending action for the wiring to the servo amplifier.
- Connecting a linear servo motor for different axis to the CNP3A, CNP3B, or CNP3C connector may cause a malfunction.

This chapter does not describe the following items. For details of the items, refer to each section of the detailed description field.

Item	Detailed explanations
Input power supply circuit	Section 3.1
Explanation of power supply system	Section 3.3
Signal (device) explanations	Section 3.5
Alarm occurrence timing chart	Section 3.7
Interfaces	Section 3.8
SSCNET III cable connection	Section 3.9
Grounding	Section 3.11
Switch setting and display of the servo amplifier	Section 4.3

14. USING A LINEAR SERVO MOTOR

14.3 Operation and functions

14.3.1 Startup

POINT	● When using the linear servo motor, set [Pr. PA01] to " _ _ 4 _".
--------------	--

(1) Startup procedure

Start up the linear servo in the following procedure.

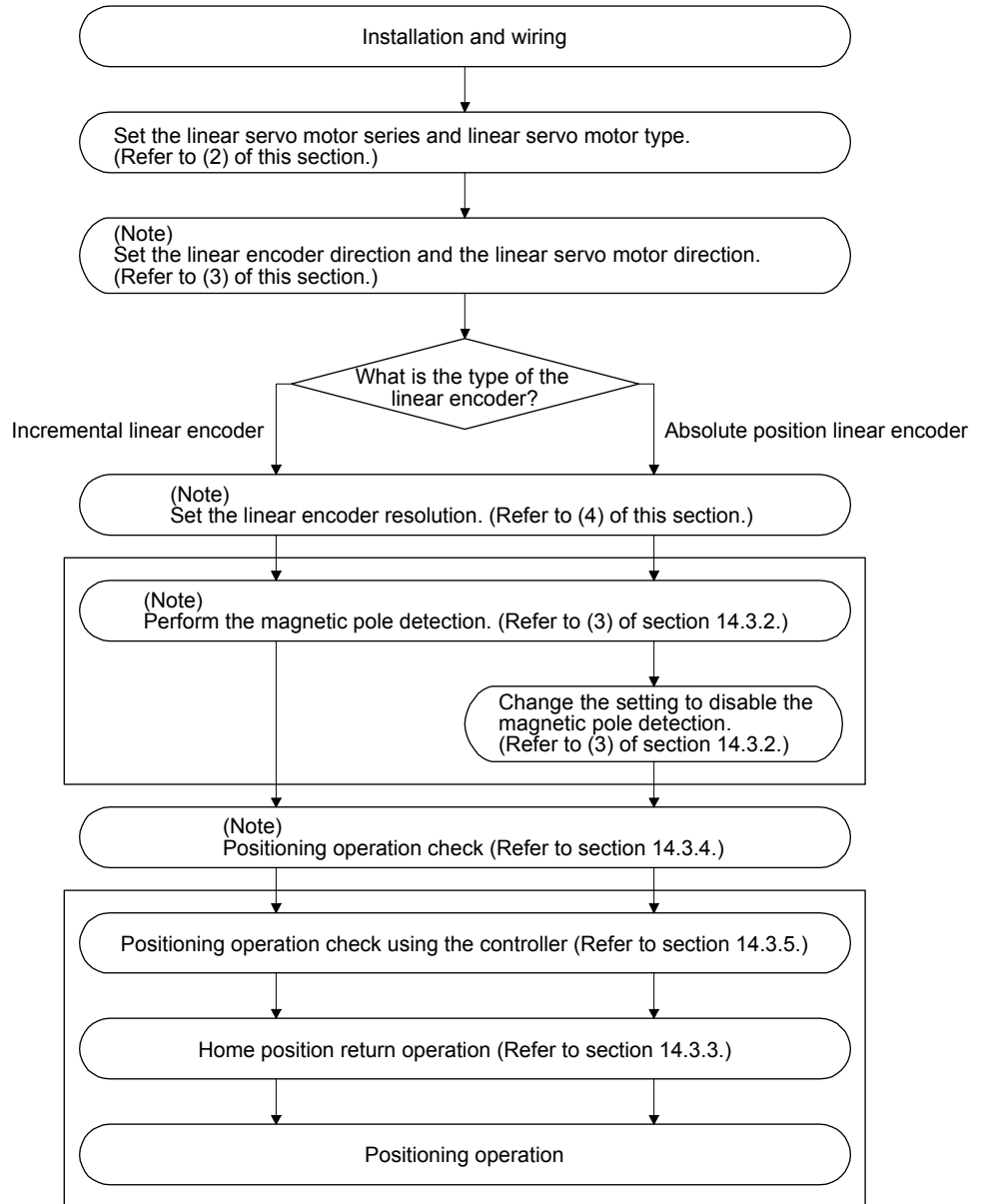

Note. Use MR Configurator2.

(2) Set the linear servo motor series and linear servo motor type.

To use the linear servo motor, set the linear servo motor series and linear servo motor type with [Pr. PA17 Servo motor series setting] and [Pr. PA18 Servo motor type setting]. (Refer to section 5.2.1.)

14. USING A LINEAR SERVO MOTOR

(3) Settings of the linear encoder direction and the linear servo motor direction

Set the first digit of [Pr. PC27] (Encoder pulse count polarity selection) so that the positive direction of the linear servo motor matches with the increasing direction of the linear encoder feedback.

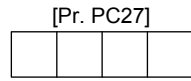

Encoder pulse count polarity selection

0: Linear servo motor positive direction and linear encoder increasing direction
1: Linear servo motor positive direction and linear encoder decreasing direction

(a) Parameter setting method

- 1) Confirm the positive direction of the linear servo motor. [Pr. PA14] determines the relation of the travel direction of the linear servo motor under commands as shown below.

[Pr. PA14] setting	Travel direction of linear servo motor	
	Address increasing command	Address decreasing command
0	Positive direction	Negative direction
1	Negative direction	Positive direction

The positive/negative directions of the linear servo motor are as follows.

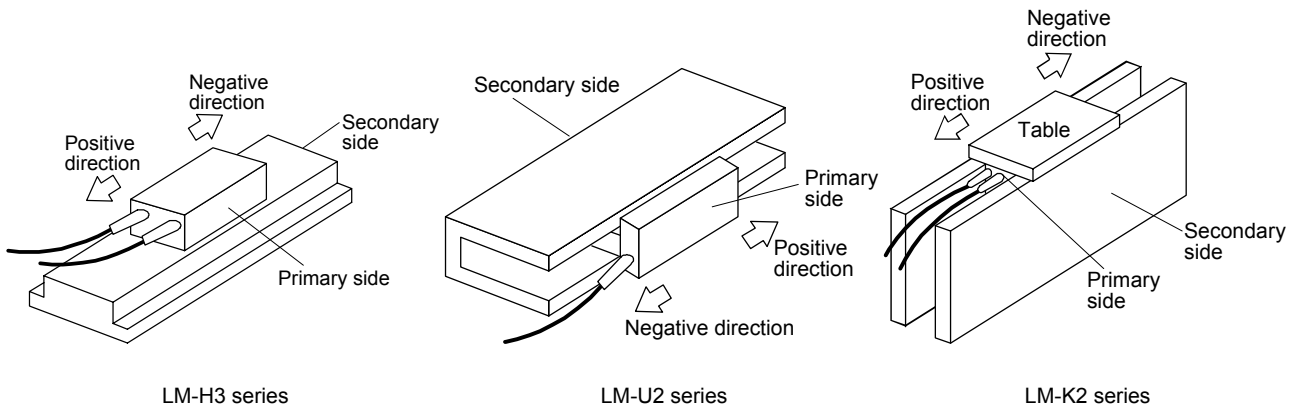

- 2) Confirm the increasing direction of the linear encoder.

- 3) If the positive direction of the linear servo motor matches with the increasing direction of the linear encoder, set [Pr. PC27] to "___0". If the positive direction of the linear servo motor does not match with the increasing direction of the linear encoder, set [Pr. PC27] to "___1".

(b) Confirmation method

Confirm the positive direction of the linear servo motor and the increasing direction of the linear encoder in the following procedure.

- 1) In servo-off status, move the linear servo motor in the positive direction manually.
- 2) Confirm the motor speed (in the positive and negative directions) at that time with MR Configurator2.

14. USING A LINEAR SERVO MOTOR

- 3) When [Pr. PC27] is set to "___ 0" and the positive direction of the linear servo motor matches with the increasing direction of the linear encoder, if the linear servo motor operates in the positive direction, the motor speed will be a positive value. If the positive direction of the linear servo motor does not match with the increasing direction of the linear encoder, the motor speed will be a negative value. When [Pr. PC27] is set to "___ 1" and the positive direction of the linear servo motor matches with the increasing direction of the linear encoder, if the linear servo motor operates in the positive direction, the motor speed will be a negative value.

(4) Linear encoder resolution setting

Set the ratio of the electronic gear to the linear encoder resolution with [Pr. PL02 Linear encoder resolution - Numerator] and [Pr. PL03 Linear encoder resolution - Denominator].

POINT
● To enable the parameter value, cycle the power after setting.

(a) Parameter setting

Set the values that apply to the following equation.

$$\frac{[\text{Pr. PL02 Linear encoder resolution - Numerator}]}{[\text{Pr. PL03 Linear encoder resolution - Denominator}]} = \text{Linear encoder resolution } [\mu\text{m}]$$

(b) Parameter setting example

When the linear encoder resolution is 0.5 μm

$$\frac{[\text{Pr. PL02}]}{[\text{Pr. PL03}]} = \text{Linear encoder resolution} = 0.5 \mu\text{m} = \frac{1}{2}$$

The following shows the simplified chart for the setting values of [Pr. PL02] and [Pr. PL03].

		Linear encoder resolution [μm]							
		0.01	0.02	0.05	0.1	0.2	0.5	1.0	2.0
Setting value	[Pr. PL02]	1	1	1	1	1	1	1	2
	[Pr. PL03]	100	50	20	10	5	2	1	1

POINT
● If an incorrect value is set for [Pr. PL02] or [Pr. PL03], the linear servo motor may not operate properly, or [AL. 27] or [AL. 42] may occur at the positioning operation or the magnetic pole detection.

14. USING A LINEAR SERVO MOTOR

14.3.2 Magnetic pole detection

Before the positioning operation of the linear servo motor, make sure to perform the magnetic pole detection. When [Pr. PL01] is set to the initial value, perform the magnetic pole detection only at the first servo-on after the power is turned on.

The magnetic pole detection includes the following two methods. Each method has advantages and disadvantages. Select a magnetic pole detection method suitable for your usage.

The position detection method is selected in the initial setting.

Magnetic pole detection	Advantage	Disadvantage
Position detection method	<ol style="list-style-type: none">1. The magnetic pole detection has a high degree of accuracy.2. The adjustment procedure at the magnetic pole detection is simple.	<ol style="list-style-type: none">1. The travel distance at the magnetic pole detection is large.2. For equipment with small friction, the initial magnetic pole detection error may occur.
Minute position detection method	<ol style="list-style-type: none">1. The travel distance at the magnetic pole detection is small.2. Even for equipment with small friction, the magnetic pole detection is available.	<ol style="list-style-type: none">1. The adjustment procedure at the magnetic pole detection is complex.2. If a disturbance occurs during the magnetic pole detection, [AL. 27 Initial magnetic pole detection error] may occur.

14. USING A LINEAR SERVO MOTOR

(1) Magnetic pole detection method by using MR Configurator2

The following shows the magnetic pole detection procedure by using MR Configurator2.

(a) Magnetic pole detection by the position detection method

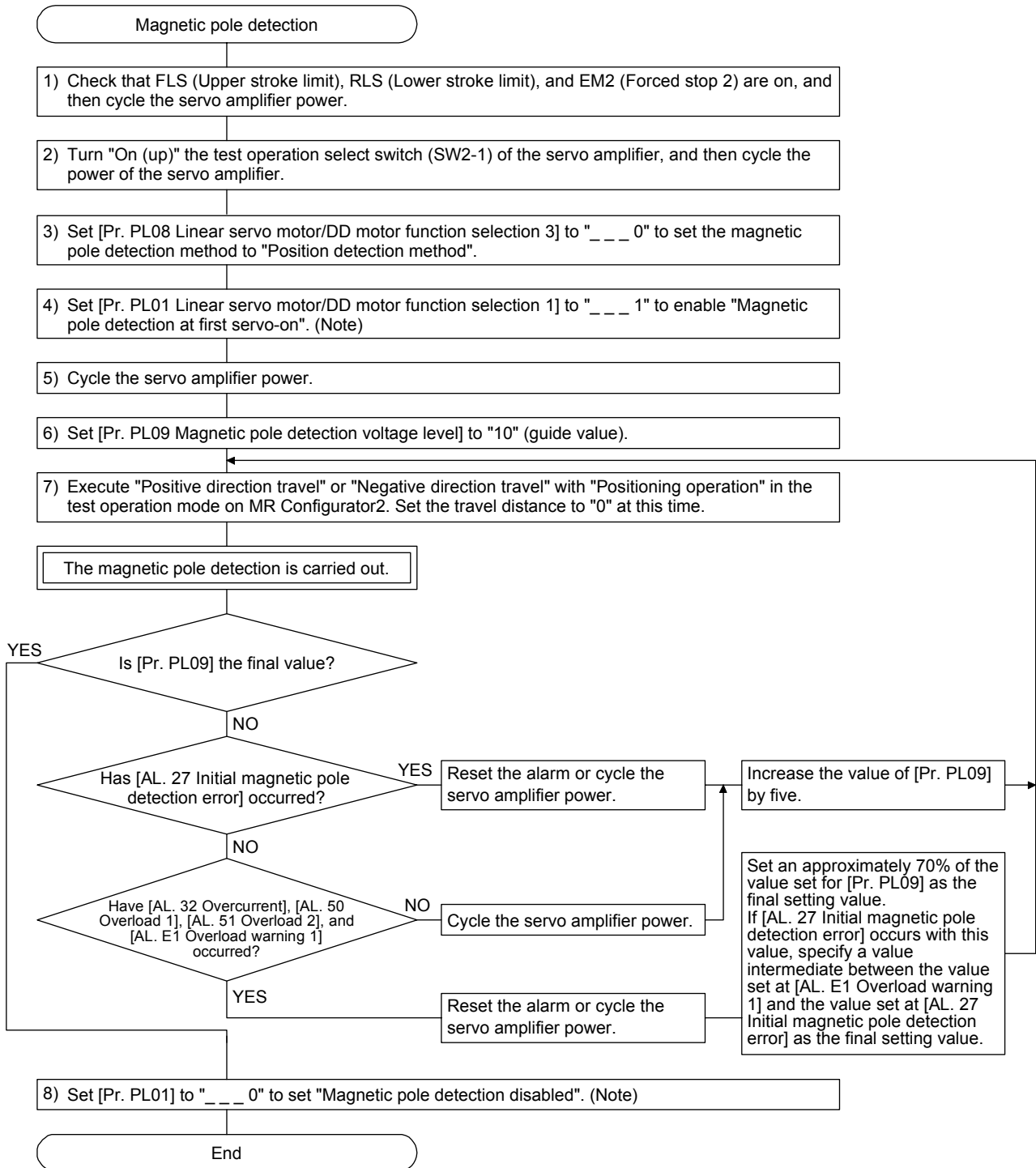

Note. For the incremental system, the [Pr. PL01] setting is not required.

14. USING A LINEAR SERVO MOTOR

(b) Magnetic pole detection by the minute position detection method

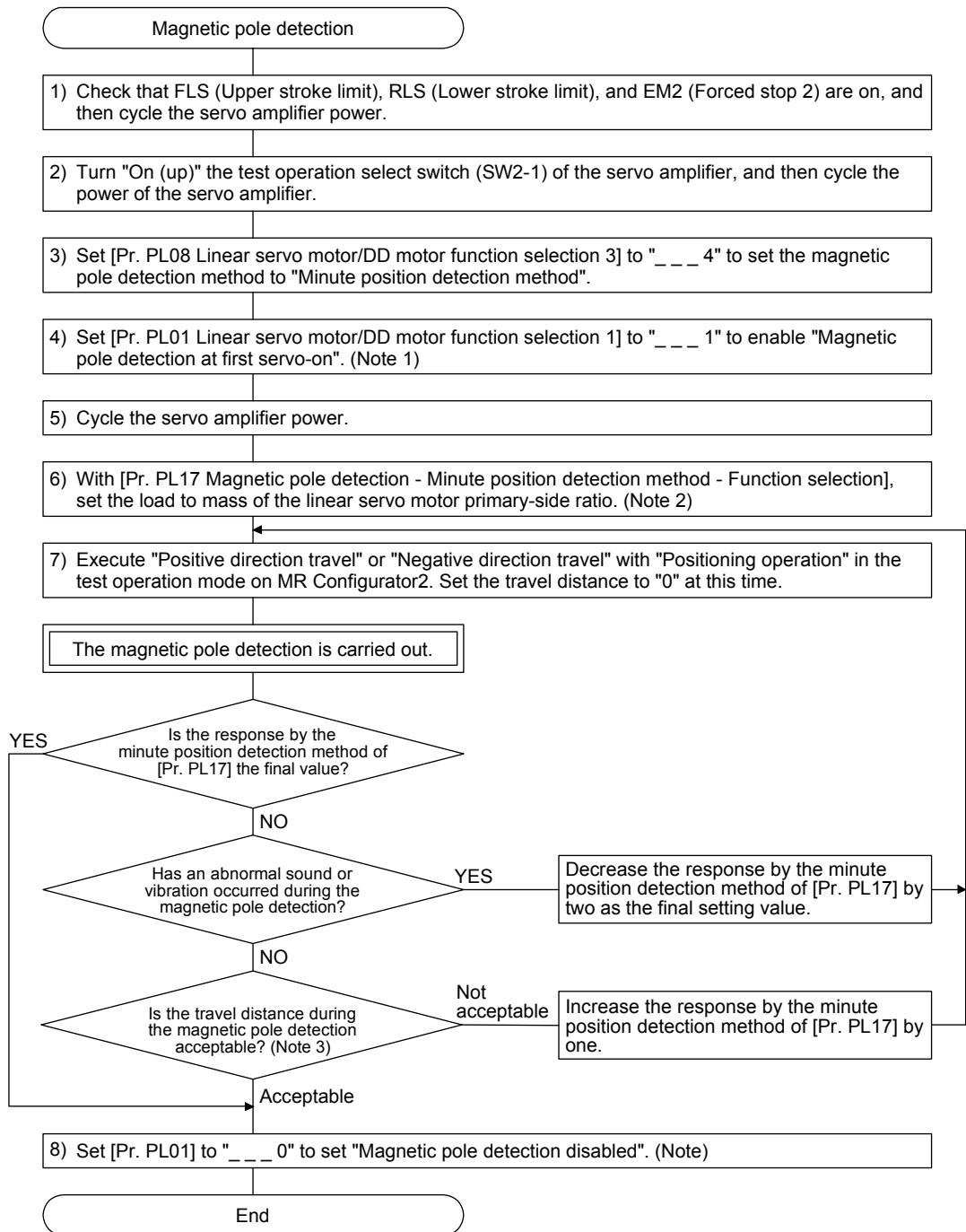

- Note
1. When the linear encoder is an incremental type, the [Pr. PL01] setting is not required.
 2. If the load to primary-side linear servo motor mass ratio is unknown, perform the magnetic pole detection by the position detection method, and then perform the auto tuning to set an estimated value.
 3. For the magnetic pole detection by the minute position detection method, the maximum travel distance at the magnetic pole detection must be 0.5 mm or less. To shorten the travel distance, increase the response by the minute position detection method in [Pr. PL17].

14. USING A LINEAR SERVO MOTOR

- (c) State transition of the servo amplifier display (3-digit, 7-segment LED) at the magnetic pole detection
 When the magnetic pole detection with MR Configurator2 is normally executed, the servo amplifier display (3-digit, 7-segment LED) shows the state as below.

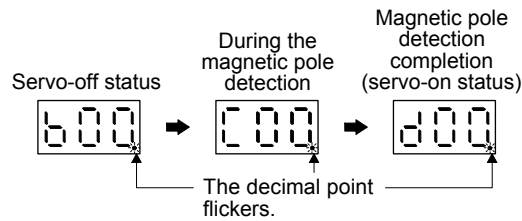

- (2) Preparation for the magnetic pole detection

POINT
<ul style="list-style-type: none"> ● When the test operation mode is selected with the test operation select switch (SW2-1), the SSCNET III/H communication for the servo amplifier in the test operation mode and the following servo amplifiers is blocked.

For the magnetic pole detection, use the test operation mode (positioning operation) of MR Configurator2. Turn off the servo amplifier power, and set the test operation select switch (SW2-1) as shown below. Turning on the power enables the test operation mode.

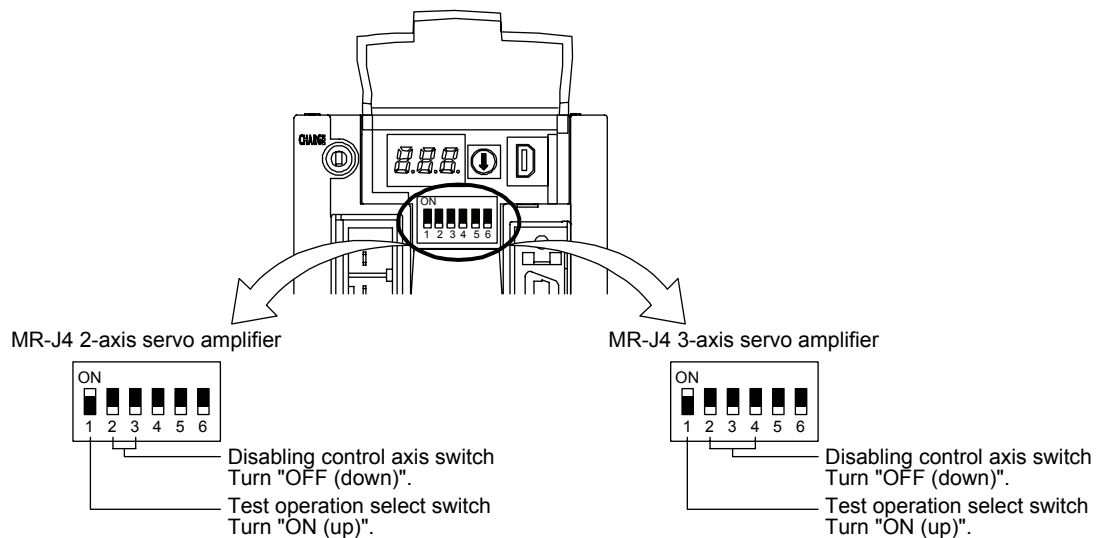

14. USING A LINEAR SERVO MOTOR

(3) Operation at the magnetic pole detection

 **WARNING** ● Note that the magnetic pole detection automatically starts simultaneously with the turning-on of the servo-on command.

 **CAUTION** ● If the magnetic pole detection is not executed properly, the linear servo motor may operate unexpectedly.

POINT

- | |
|---|
| <ul style="list-style-type: none">● Establish the machine configuration using FLS (Upper stroke limit) and RLS (Lower stroke limit). Otherwise, the machine may be damaged due to a collision.● At the magnetic pole detection, whether the linear servo motor moves in the positive or negative direction is unpredictable.● Depending on the setting value of [Pr. PL09 Magnetic pole detection voltage level], an overload, overcurrent, magnetic pole detection alarm, or others may occur.● When performing the positioning operation from a controller, use the sequence which confirms the normal completion of the magnetic pole detection and the servo-on status, then outputs the positioning command. If the controller outputs the positioning command before RD (Ready) turns on, the command may not be accepted or a servo alarm may occur.● After the magnetic pole detection, check the positioning accuracy with the test operation (positioning operation function) of MR Configurator2.● When the absolute position linear encoder is used, if a gap is generated to the positional relation between the linear encoder and the linear servo motor, perform the magnetic pole detection again.● The accuracy of the magnetic pole detection improves with no load.● A servo alarm may occur when the linear encoder is not mounted properly, or when the linear encoder resolution setting ([Pr. PL02] and [Pr. PL03]) or the setting value of [Pr. PL09 Magnetic pole detection voltage level] is incorrect.● For the machine that its friction becomes 30% or more of the continuous thrust, the linear servo motor may not operate properly after the magnetic pole detection.● For the horizontal shaft of the machine that its unbalanced thrust becomes 20% or more of the continuous thrust, the linear servo motor may not operate properly after the magnetic pole detection.● For the machine that multiple axes are connected like a tandem configuration, if you try to perform the magnetic pole detection simultaneously for multiple axes, the magnetic pole detection may not be executed. Perform the magnetic pole detection for each axis. At this time, set the axes that the magnetic pole detection is not performed for to servo-off. |
|---|

14. USING A LINEAR SERVO MOTOR

(a) For the incremental linear encoder

POINT	<p>● For the incremental linear encoder, the magnetic pole detection is required every time the power is turned on.</p>
--------------	---

By turning on the servo-on command from the controller after the power-on, the magnetic pole detection is automatically carried out. Therefore, there is not need to set the parameter (first digit of [Pr. PL01]) for executing the magnetic pole detection.

1) Timing chart

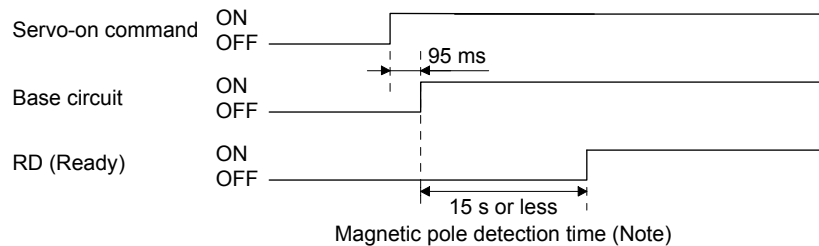

Note. The magnetic pole detection time indicates the operation time when FLS (Upper stroke limit) and RLS (Lower stroke limit) are on.

2) Linear servo motor movement (when FLS (Upper stroke limit) and RLS (Lower stroke limit) are on)

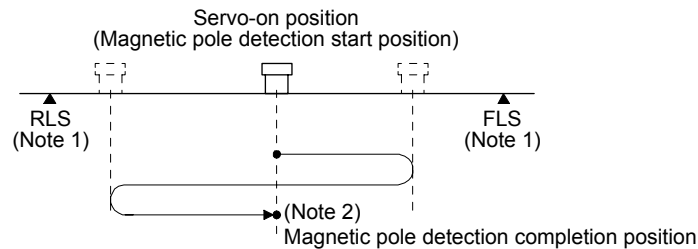

Note 1. When FLS (Upper stroke limit) or RLS (Lower stroke limit) turns off during the magnetic pole detection, the operation of the magnetic pole detection is carried on to the opposite direction. When both FLS and RLS are off, [AL. 27 Initial magnetic pole detection error] occurs.

2. The following shows the pitch against the magnetic pole.

Linear servo motor series	LM-H3	LM-U2		LM-K2
		Medium thrust (Continuous thrust: Less than 400 N)	Large thrust (Continuous thrust: 400 N or more)	
Pitch against magnetic pole [mm]	48	30	60	48

14. USING A LINEAR SERVO MOTOR

- 3) Linear servo motor movement (when FLS (Upper stroke limit) or RLS (Lower stroke limit) is off)
When FLS or RLS is off at servo-on, the magnetic pole detection is carried out as follows.

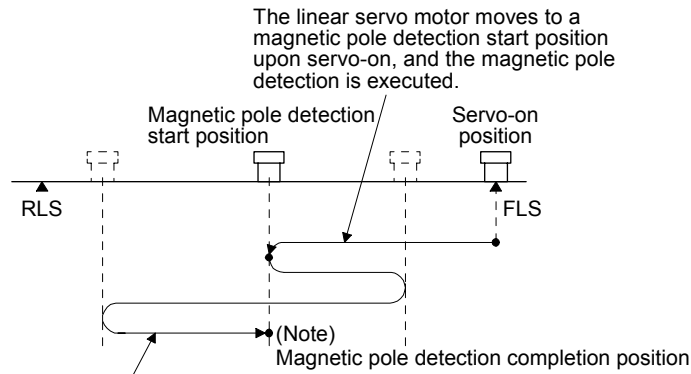

The linear servo motor reciprocates several times and returns to the magnetic pole detection start position to complete the magnetic pole detection and to go into the servo-lock status. At this time, there may be a gap, approximately a quarter of the pitch against magnetic pole, from the start position.

Note. For the pitch against magnetic pole, refer to (3) (a) 2) Note 2 of this section.

- (b) For the absolute position linear encoder

POINT
<ul style="list-style-type: none"> ● When you use an absolute position linear encoder with the following timings, the magnetic pole detection will be required. <ul style="list-style-type: none"> ▪ When the system is set up (at the first startup of equipment) ▪ After a servo amplifier is replaced ▪ After a linear servo motor (primary-side or secondary-side) is replaced ▪ After a linear encoder (scale or head) is replaced or its position is adjusted ● When the absolute position linear encoder is used, if a gap is generated to the positional relation between the linear encoder and the linear servo motor, perform the magnetic pole detection again.

Perform the magnetic pole detection in the following procedure.

- 1) Set [Pr. PL01 Linear servo motor/DD motor function selection 1] to "___ 1" (Magnetic pole detection at first servo-on).

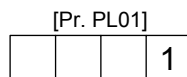

Magnetic pole detection at first servo-on (Initial value)

- 2) Execute the magnetic pole detection. (Refer to (3) (a) 1), 2) of this section.)

14. USING A LINEAR SERVO MOTOR

- 3) After the completion of the magnetic pole detection, change [Pr. PL01] to " __ _ 0" (Magnetic pole detection disabled).

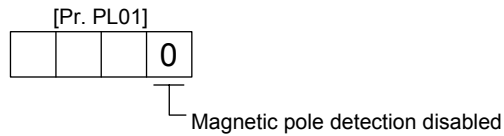

After the magnetic pole detection, by disabling the magnetic pole detection function with [Pr. PL01], the magnetic pole detection after each power-on is not required.

- (4) Magnetic pole detection method setting

POINT
<p>● In the following cases, set the magnetic pole detection method to the minute position detection method.</p> <ul style="list-style-type: none"> ▪ When a shorten travel distance at the magnetic pole detection is required ▪ When the magnetic pole detection by the position detection method is not completed

Set the magnetic pole detection method using the first digit of [Pr. PL08] (Magnetic pole detection method selection).

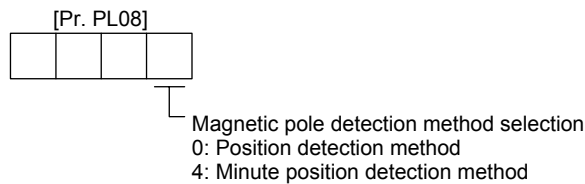

- (5) Setting of the magnetic pole detection voltage level by the position detection method

For the magnetic pole detection by the position detection method, set the voltage level with [Pr. PL09 Magnetic pole detection voltage level]. For the magnetic pole detection by the minute position detection method, the voltage level setting is not required.

- (a) Guideline of parameter settings

Set the parameters by referring to the following table.

	[Pr. PL09] setting (guide value)	
Servo status	Small ← Medium → Large (10 or less (initial value) 50 or more)	
Thrust at operation	Small	Large
Overload, overcurrent alarm	Seldom occurs	Frequently occurs
Magnetic pole detection alarm	Frequently occurs	Seldom occurs
Magnetic pole detection accuracy	Low	High

- (b) Setting procedure

- 1) Perform the magnetic pole detection, and increase the setting value of [Pr. PL09 Magnetic pole detection voltage level] until [AL. 50 Overload 1], [AL. 51 Overload 2], [AL. 33 Overvoltage], [AL. E1 Overload warning 1], and [AL. EC Overload warning 2] occur. Increase the setting value by five as a guide value. When these alarms and warnings occur during the magnetic pole detection by using MR Configurator2, the test operation of MR Configurator2 automatically completes and the servo-off status is established.

14. USING A LINEAR SERVO MOTOR

- 2) Specify the setting value that is an approximately 70% of the value set when [AL. 50 Overload 1], [AL. 51 Overload 2], [AL. 33 Overvoltage], [AL. E1 Overload warning 1], and [AL. EC Overload warning 2] occurred as the final setting value. However, if [AL. 27 Initial magnetic pole detection error] occurs with this value, specify a value intermediate between the value set at [AL. 50 Overload 1], [AL. 51 Overload 2], [AL. 33 Overvoltage], [AL. E1 Overload warning 1], and [AL. EC Overload warning 2] and the value set at the magnetic pole detection alarm as the final setting value.
- 3) Perform the magnetic pole detection again with the final setting value to check there is no problem.

(c) Setting example

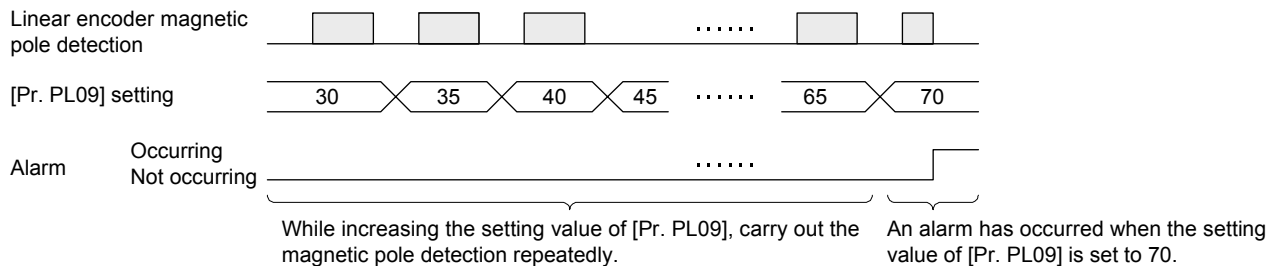

In this example, the final setting value of [Pr. PL09] is 49 (Setting value at the alarm occurrence = 70×0.7).

14.3.3 Home position return

POINT
<ul style="list-style-type: none"> ● The incremental linear encoder and the absolute position linear encoder have different reference home positions at the home position return.

(1) Incremental linear encoder

<p>CAUTION</p>	<ul style="list-style-type: none"> ● If the resolution or the stop interval (the third digit of [Pr. PL01]) of the linear encoder is large, it is very dangerous since the linear servo motor may crash into the stroke end.
-----------------------	---

14. USING A LINEAR SERVO MOTOR

- (a) When the linear encoder home position (reference mark) exists in the home position return direction
 When an incremental linear encoder is used, the home position is the position per 1048576 pulses (changeable with the third digit of [Pr. PL01]) with reference to the linear encoder home position (reference mark) passed through first after a home position return start. Change the setting value of [Pr. PL01] according to the linear encoder resolution.

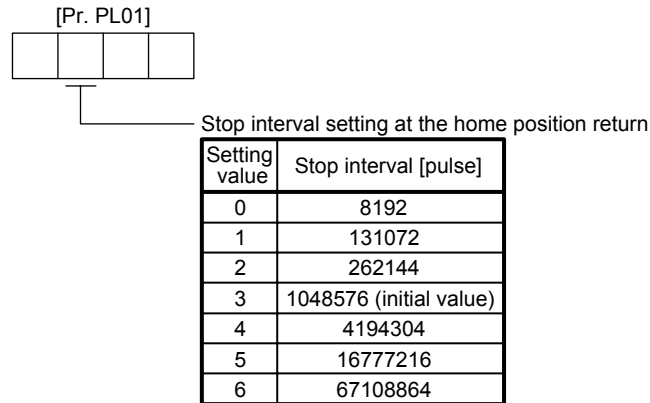

The following shows the relation between the stop interval at the home position return and the linear encoder resolution. For example, when the linear encoder resolution is 0.001 μm and the parameter for the stop interval at the home position return, [Pr.PL01], is set to "_ 5 _" (16777216 pulses), the stop interval is 16.777 mm. The value inside a bold box indicates the recommended stop interval for each linear encoder resolution.

[Unit: mm]

Pr. PL01	Linear encoder resolution [μm] Stop interval [pulse]	0.001	0.005	0.01	0.02	0.05	0.1	0.2	0.5	1	2
		_ 0 _	8192	0.008	0.041	0.082	0.164	0.410	0.819	1.638	4.096
_ 1 _	131072	0.131	0.655	1.311	2.621	6.554	13.107	26.214	65.536	131.072	262.144
_ 2 _	262144	0.262	1.311	2.621	5.243	13.107	26.214	52.429	131.072	262.144	524.288
_ 3 _	1048576	1.049	5.243	10.486	20.972	52.429	104.858	209.715	524.288	1048.576	2097.152
_ 4 _	4194304	4.194	20.972	41.943	83.886	209.715	419.430	838.861	2097.152	4194.304	8388.608
_ 5 _	16777216	16.777	83.886	167.772	335.544	838.861	1677.722	3355.443	8388.608	16777.216	33554.432
_ 6 _	67108864	67.109	335.544	671.089	1342.177	3355.443	6710.886	13421.773	33554.432	67108.864	134217.728

14. USING A LINEAR SERVO MOTOR

In the case of a proximity dog type home position return, the nearest reference home position after proximity dog off is the home position.

Set one linear encoder home position in the full stroke, and set it in the position that can always be passed through after a home position return start. LZ (Encoder Z-phase pulse) cannot be used.

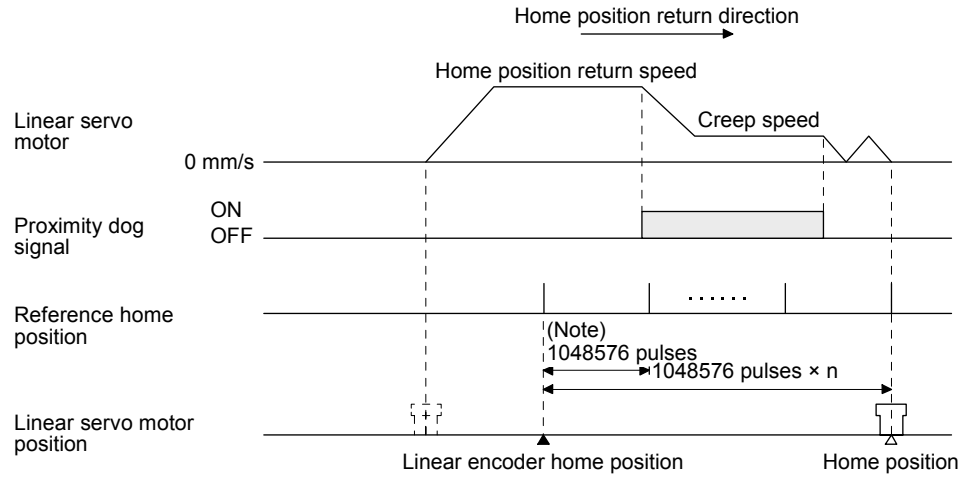

Note. Changeable with [Pr. PL01].

(b) When the linear encoder home position does not exist in the home position return direction

If the home position return is performed from the position where the linear encoder does not exist in the home position return direction, a home position return error occurs on the controller. The error contents differ according to the controller type. Move the linear servo motor to the stroke end on the opposite side of the home position return direction with the JOG operation from the controller and others, and then perform a home position return.

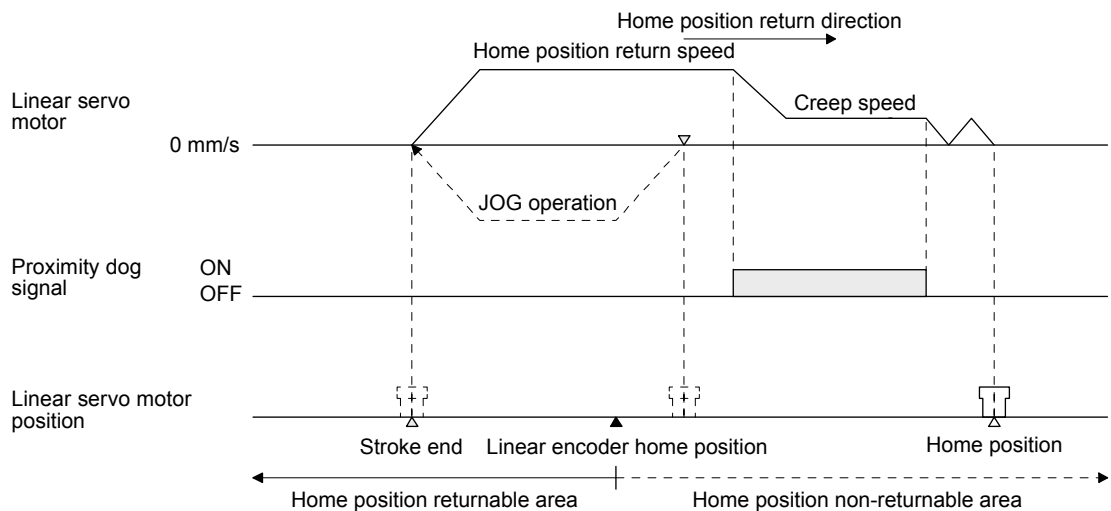

POINT

- To execute a home position return securely, start a home position return after moving the linear servo motor to the opposite stroke end with JOG operation from the controller and others.
- Change the third digit value of [Pr. PL01] according to the linear encoder resolution.

14. USING A LINEAR SERVO MOTOR

(2) Absolute position linear encoder

When an absolute linear encoder is used, the reference home position is the position per 1048576 pulses (changeable with the third digit of [Pr. PL01]) with reference to the linear encoder home position (absolute position data = 0).

In the case of a proximity dog type home position return, the nearest reference home position after proximity dog off is the home position. The linear encoder home position can be set in any position. LZ (Encoder Z-phase pulse) cannot be used.

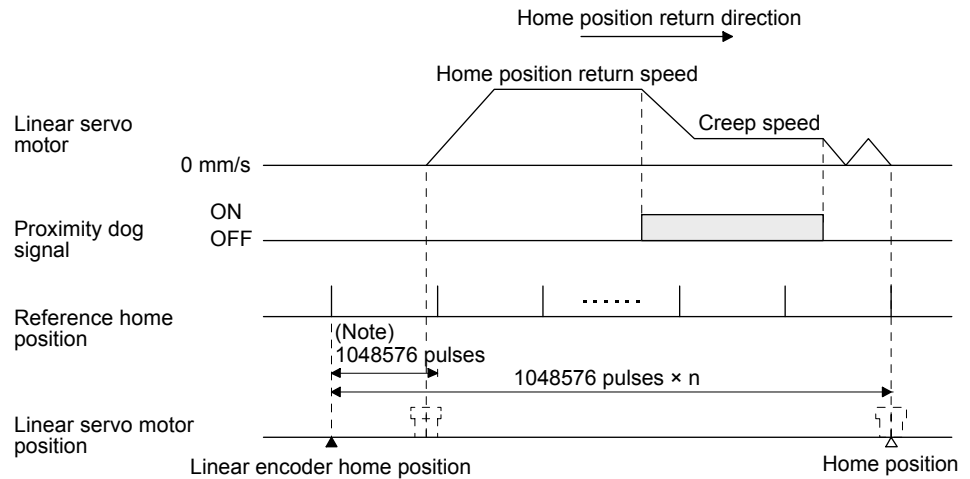

Note. Changeable with [Pr. PL01].

POINT

- The data set type home position return can also be carried out.

14.3.4 Test operation mode in MR Configurator2

CAUTION

- The test operation mode is designed for checking servo operation. It is not for checking machine operation. Do not use this mode with the machine. Always use the linear servo motor alone.
- If the servo motor operates abnormally, use EM2 (Forced stop 2) to stop it.

POINT

- The content described in this section indicates the environment where the servo amplifier and a personal computer are directly connected.
- For the MR-J4 multi-axis servo amplifier, all axes go into the test operation mode simultaneously, but only A-axis, B-axis, or C-axis can be operated.
- When the test operation mode is selected with the test operation select switch (SW2-1), the SSCNET III/H communication for the servo amplifier in the test operation mode and the following servo amplifiers is blocked.

By using a personal computer and MR Configurator2, you can execute the positioning operation, the output signal (DO) forced output, and the program operation without connecting the servo system controller.

14. USING A LINEAR SERVO MOTOR

(1) Test operation mode type

(a) Positioning operation

Positioning operation can be performed without using the servo system controller. Use this operation with the forced stop reset. This operation can be used independently of whether the servo is on or off and whether the servo system controller is connected or not.

Exercise control on the positioning operation screen of MR Configurator2.

1) Operation pattern

Item	Initial value	Setting range
Travel distance [pulse]	1048576	0 to 99999999
Speed [mm/s]	10	0 to Maximum speed
Acceleration/deceleration time constant [ms]	1000	0 to 50000
Repeat pattern	Positive direction travel → Negative direction travel	Positive direction travel → Negative direction travel Positive direction travel → Positive direction travel Negative direction travel → Positive direction travel Negative direction travel → Negative direction travel
Dwell time [s]	2.0	0.1 to 50.0
Number of repeats [time]	1	1 to 9999

2) Operation method

Operation	Screen control
Positive direction travel	Click the "Positive Direction Movement" button.
Negative direction travel	Click the "Reverse Direction Movement" button.
Pause	Click the "Pause" button.
Stop	Click the "Stop" button.
Forced stop	Click the "Forced stop" button.

(b) Output signal (DO) forced output

Output signals can be switched on/off forcibly independently of the servo status. This function is used for output signal wiring check, etc. Exercise control on the DO forced output screen of MR Configurator2.

(c) Program operation

Positioning operation can be performed in two or more operation patterns combined, without using the servo system controller. Use this operation with the forced stop reset. This operation may be used independently of whether the servo is on or off and whether the servo system controller is connected or not.

Exercise control on the program operation screen of MR Configurator2. For full information, refer to the MR Configurator2 Installation Guide.

Operation	Screen control
Start	Click the "Operation start" button.
Pause	Click the "Pause" button.
Stop	Click the "Stop" button.
Forced stop	Click the "Forced stop" button.

14. USING A LINEAR SERVO MOTOR

(2) Operation procedure

- 1) Turn off the power.
- 2) Turn "ON (up)" SW2-1.

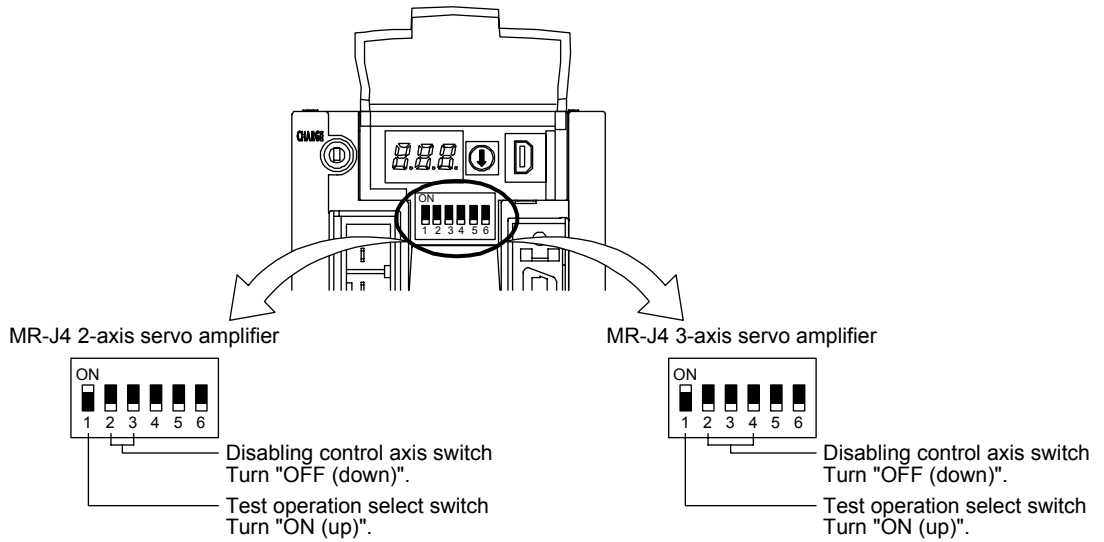

Turning "ON (up)" SW2-1 during power-on will not enable the test operation mode.

3) Turn on the servo amplifier.

When initialization is over, the display shows the following screen.

Example: MR-J4 2-axis servo amplifier

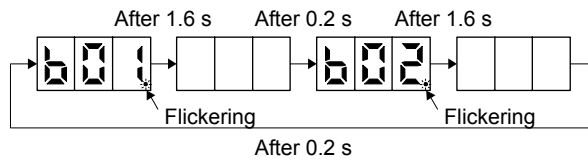

4) Start operation with the personal computer.

14. USING A LINEAR SERVO MOTOR

14.3.5 Operation from controller

The linear servo can be used with any of the following controllers.

Servo system controller	Model
Motion controller	Q17_DSCPU
Simple motion module	QD77MS_

(1) Operation method

POINT
● For the machine that multiple axes are connected like a tandem configuration, if you try to perform the magnetic pole detection simultaneously for multiple axes, the magnetic pole detection may not be executed. Perform the magnetic pole detection for each axis. At this time, set the axes that the magnetic pole detection is not performed for to servo-off.

For the system using the incremental linear encoder, the magnetic pole detection is automatically performed at the first servo-on after the power-on. For this reason, when performing the positioning operation, create the sequence which surely confirms the servo-on status as the inter lock condition of the positioning command.

Also, some parameter settings and the home position return type differ according to the controller type.

14. USING A LINEAR SERVO MOTOR

(2) Servo system controller setting

(a) Setting precautions

The following parameters will be enabled by turning the servo amplifier power off and on again after the controller writes the parameters to the servo amplifier.

Setting item					Setting		
					Motion controller Q17_DSCPU	Simple motion module QD77MS_	
Command resolution					Linear encoder resolution unit		
Servo amplifier setting					MR-J4-B Linear		
Motor setting					Automatic setting		
Parameter	No.	(Note) Symbol	Name	Initial value	Set the items as required.		
	PA01	**STY	Operation mode	1000h			1040h
	PC01	ERZ	Error excessive alarm level	0			
	PC03	*ENRS	Encoder output pulse selection	0000h			
	PC27	**COP9	Function selection C-9	0000h			
	PL01	**LIT1	Linear servo motor/DD motor function selection 1	0301h			
	PL02	**LIM	Linear encoder resolution - Numerator	1000			
	PL03	**LID	Linear encoder resolution - Denominator	1000			
	PL04	*LIT2	Linear servo motor/DD motor function selection 2	0003h			
	PL05	LB1	Position deviation error detection level	0			
	PL06	LB2	Speed deviation error detection level	0			
	PL07	LB3	Torque/thrust deviation error detection level	100			
	PL08	*LIT3	Linear servo motor/DD motor function selection 3	0010h			
	PL09	LPWM	Magnetic pole detection voltage level	30			
	PL17	LTSTS	Magnetic pole detection - Minute position detection method - Function selection	0000h			
PL18	IDLV	Magnetic pole detection - Minute position detection method - Identification signal amplitude	0				
Positioning control parameter	Unit setting				mm		
	Number of pulses (AP)				Refer to (2) (b) of this section.		
	Travel distance (AL)						

Note. The parameter whose symbol is preceded by * is enabled with the following conditions:

* : After setting the parameter, power off and on the servo amplifier or reset the controller.

** : After setting the parameter, cycle the power of the servo amplifier.

14. USING A LINEAR SERVO MOTOR

(b) Settings of the number of pulses (AP) and travel distance (AL)

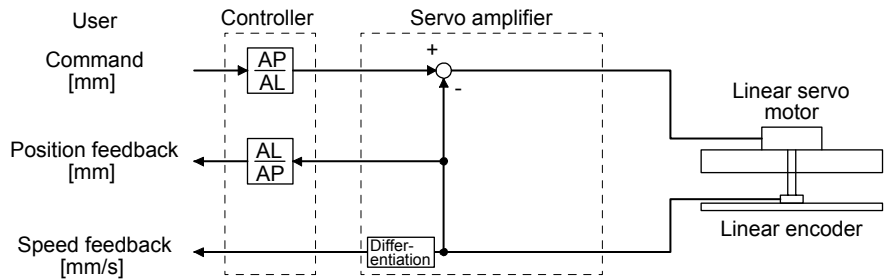

Calculate the number of pulses (AP) and travel distance (AL) of the linear encoder in the following conditions.

When the linear encoder resolution is 0.05 μm

$$\frac{\text{Number of pulses (AP) [pulse]}}{\text{Travel distance (AL) [μm]}} = \frac{1}{0.05} = \frac{20}{1}$$

14.3.6 Function

(1) Linear servo control error detection function

POINT
<p>● For the linear servo control error detection function, the position and speed deviation error detections are enabled by default. ([Pr. PL04]: __ _ 3)</p>

If the linear servo control gets unstable for some reasons, the linear servo motor may not operate properly. To detect this state and to stop operation, the linear servo control error detection function is used as a protective function.

The linear servo control error detection function has three different detection methods: the position deviation, speed deviation, and thrust deviation. An error is detected when each method is enabled with [Pr. PL04 Linear servo motor/DD motor function selection 2]. The detection level can be changed with [Pr. PL05], [Pr. PL06], and [Pr. PL07].

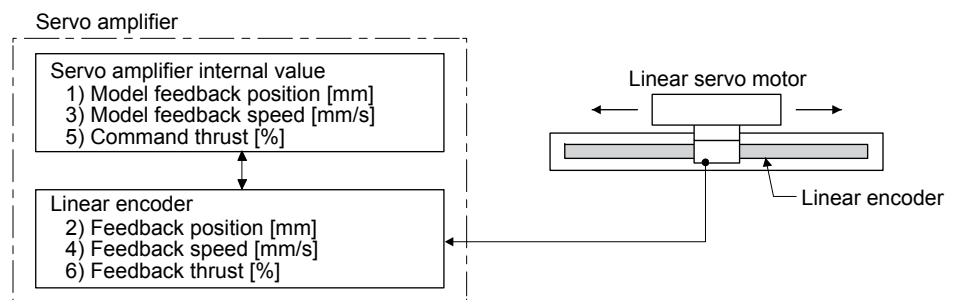
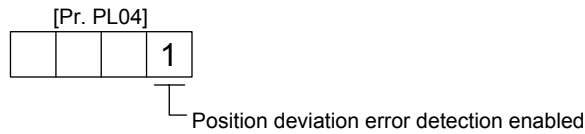

Figure 14.1 Outline of linear servo control error detection function

14. USING A LINEAR SERVO MOTOR

(a) Position deviation error detection

Set [Pr. PL04] to "___ 1" to enable the position deviation error detection.



When you compare the model feedback position (1)) and the feedback position (2)) in figure 14.1, if the deviation is more than the value of [Pr. PL05 Position deviation error detection level] (1 mm to 1000 mm), [AL. 42.1 Servo control error by position deviation] will occur and the linear servo motor will stop. The initial value of this detection level is 50 mm. Replace the set value as required.

(b) Speed deviation error detection

Set [Pr. PL04] to "___ 2" to enable the speed deviation error detection.

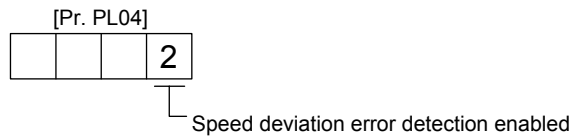

When you compare the model feedback speed (3)) and the feedback speed (4)) in figure 14.1, if the deviation is more than the value of [Pr. PL06 Speed deviation error detection level] (1 mm/s to 5000 mm/s), [AL. 42.2 Servo control error by speed deviation] will occur and the linear servo motor will stop. The initial value of this detection level is 1000 mm/s. Replace the set value as required.

(c) Thrust deviation error detection level

Set [Pr. PL04] to "___ 4" to enable the thrust deviation error detection.

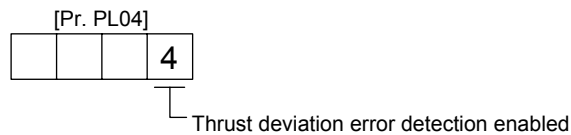

When you compare the command thrust (5)) and the feedback thrust (6)) in figure 14.1, if the deviation is more than the value of [Pr. PL07 Torque/thrust deviation error detection level] (1% to 1000%), [AL. 42.3 Servo control error by torque/thrust deviation] will occur and the linear servo motor will stop. The initial value of this detection level is 100%. Replace the set value as required.

(d) Detecting multiple deviation errors

When setting [Pr. PL04] as shown below, multiple deviation errors can be detected. For the error detection methods, refer to (1) (a), (b), (c) of this section.

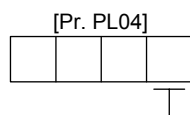

Setting value	Position deviation error detection	Speed deviation error detection	Thrust deviation error detection
1	○	—	—
2	—	○	—
3	○	○	—
4	—	—	○
5	○	—	○
6	—	○	○
7	○	○	○

14. USING A LINEAR SERVO MOTOR

(2) Auto tuning function

The auto tuning function during the linear servo motor operation is the same as that of the rotary servo motor. However, the calculation method of the load to motor mass ratio (J ratio) differs. The load to motor mass ratio (J ratio) on the linear servo motor is calculated by dividing the load mass by the mass of the linear servo motor primary side.

Example) Mass of linear servo motor primary side = 2 kg
Load mass (excluding the mass of the linear servo motor primary side) = 4 kg
Mass ratio = $4/2 = 2$ times

For the parameters set by the auto tuning function, refer to chapter 6.

POINT
<ul style="list-style-type: none">● The auto tuning mode 1 may not be performed properly if the following conditions are not satisfied.<ul style="list-style-type: none">▪ Time to reach 2000 mm/s is the acceleration/deceleration time constant of 5 s or less.▪ The linear servo motor speed is 150 mm/s or higher.▪ The load to mass of the linear servo motor primary-side ratio is 100 times or less.▪ The acceleration/deceleration thrust is 10% or less of the continuous thrust.

(3) Machine analyzer function

POINT
<ul style="list-style-type: none">● Make sure to perform the machine analyzer function after the magnetic pole detection. If the magnetic pole detection is not performed, the machine analyze function may not operate properly.● The stop position at the completion of the machine analyzer function can be any position.

14.3.7 Absolute position detection system

When the linear servo motor is used in the absolute position detection system, an absolute position linear encoder is required. The linear encoder backs up the absolute position data. Therefore, the encoder battery case (MR-BT6VCASE) and the battery (MR-BAT6V1) need not be installed to the servo amplifier. Additionally, [AL. 25 Absolute position erased], [AL. 92 Battery cable disconnection warning], [AL. 9F Battery warning], and [AL. E3 Absolute position counter warning] are not provided for the linear servo motor.

14. USING A LINEAR SERVO MOTOR

14.4 Characteristics

14.4.1 Overload protection characteristics

An electronic thermal relay is built in the servo amplifier to protect the linear servo motor, servo amplifier and linear servo motor power wires from overloads.

[AL. 50 Overload 1] occurs if overload operation performed is above the electronic thermal protection curve shown in fig. 14.2. [AL. 51 Overload 2] occurs if the maximum current is applied continuously for several seconds due to machine collision, etc. Use the equipment on the left-side area of the continuous or broken line in the graph.

This servo amplifier has solid-state linear servo motor overload protection. (The servo motor overload current (full load current) is set on the basis of 120% rated current of the servo amplifier.)

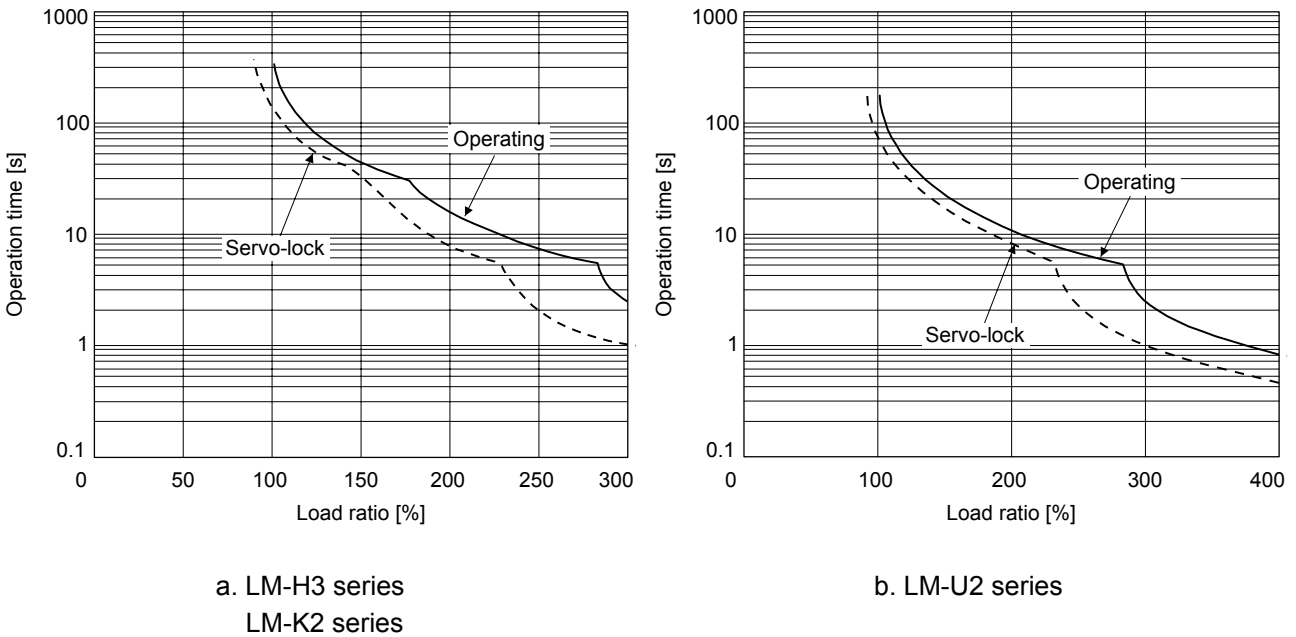

Fig. 14.2 Electronic thermal relay protection characteristics

14. USING A LINEAR SERVO MOTOR

14.4.2 Power supply capacity and generated loss

Calculate the generated loss and the power supply capacity of the servo amplifier under rated load from (1) and (2) in this section. The calculated value will vary depending on the number of connected linear servo motors and the capacities of the linear servo motors. For thermal design of an enclosed type cabinet, use the values calculated in consideration for the worst operating conditions. The actual amount of generated heat will be intermediate between values at rated torque and servo-off according to the duty used during operation. When the linear servo motor is run at less than the rated speed, the power supply capacity will be smaller than the calculated value, but the servo amplifier's generated heat will not change.

(1) Calculation method of power supply capacity

Calculate the power supply capacity for one servo amplifier from tables 14.1 and 14.2.

Table 14.1 Power supply capacity for one servo amplifier at rated output

Servo amplifier	(Note) Power supply capacity [kVA]
MR-J4W2-22B	Total power supply capacity of connected linear servo motors ((A) in table 14.2)
MR-J4W2-44B	
MR-J4W2-77B	
MR-J4W2-1010B	
MR-J4W3-222B	
MR-J4W3-444B	

Note. Note that the power supply capacity will vary according to the power supply impedance. This value is applicable when the power factor improving reactor is not used.

Table 14.2 Servo amplifier power supply capacity for one linear servo motor

Linear servo motor	Power supply capacity [kVA] (A)
LM-H3P2A-07P-BSS0	0.9
LM-H3P3A-12P-CSS0	0.9
LM-H3P3B-24P-CSS0	1.3
LM-H3P3C-36P-CSS0	1.9
LM-H3P7A-24P-ASS0	1.3
LM-U2PAB-05M-0SS0	0.5
LM-U2PAD-10M-0SS0	0.9
LM-U2PAF-15M-0SS0	0.9
LM-U2PBB-07M-1SS0	0.5
LM-U2PBD-15M-1SS0	1.0
LM-U2PBF-22M-1SS0	1.3
LM-K2P1A-01M-2SS1	0.9
LM-K2P2A-02M-1SS1	1.3

Calculate the power supply capacity with equation 10.1 in (1) in section 10.2.

14. USING A LINEAR SERVO MOTOR

(2) Calculation method of the amount of heat generated by the servo amplifier

Calculate the amount of heat generated by one servo amplifier from tables 14.3 and 14.4.

Table 14.3 Amount of heat generated by one servo amplifier at rated output

Servo amplifier	(Note) Servo amplifier-generated heat [W]	
	With servo-off (C)	At rated output
MR-J4W2-22B	20	Sum of the total amount of heat generated by the servo amplifier for each linear servo motor ((B) in table 14.4) and the amount of heat generated by the servo amplifier with servo-off (C)
MR-J4W2-44B	20	
MR-J4W2-77B	20	
MR-J4W2-1010B	20	
MR-J4W3-222B	20	
MR-J4W3-444B	25	

Note. Heat generated during regeneration is not included in the servo amplifier-generated heat. To calculate heat generated by the regenerative option, refer to section 11.2.

Table 14.4 Amount of heat generated by one servo amplifier for one linear servo motor

Servo motor	Servo amplifier-generated heat [W] (B)
LM-H3P2A-07P-BSS0	35
LM-H3P3A-12P-CSS0	35
LM-H3P3B-24P-CSS0	50
LM-H3P3C-36P-CSS0	75
LM-H3P7A-24P-ASS0	50
LM-U2PAB-05M-0SS0	25
LM-U2PAD-10M-0SS0	35
LM-U2PAF-15M-0SS0	35
LM-U2PBB-07M-1SS0	25
LM-U2PBD-15M-1SS0	40
LM-U2PBF-22M-1SS0	50
LM-K2P1A-01M-2SS1	35
LM-K2P2A-02M-1SS1	50

Calculate the amount of heat generated by the servo amplifier with equation 10.2 in (2) in section 10.2.

14. USING A LINEAR SERVO MOTOR

14.4.3 Dynamic brake characteristics

POINT
<ul style="list-style-type: none"> ● Do not use dynamic brake to stop in a normal operation as it is the function to stop in emergency. ● For a machine operating at the recommended load to motor mass ratio or less, the estimated number of usage times of the dynamic brake is 1000 times while the machine decelerates from the rated speed to a stop once in 10 minutes. ● Be sure to enable EM1 (Forced stop 1) after the linear servo motor stops when using EM1 (Forced stop 1) frequently in other than emergency.

The approximate coasting distance from when the dynamic brake is activated until when the linear servo motor stops can be calculated with the equation below.

$$L_{max} = V_0 \cdot (0.03 + M \cdot (A + B \cdot V_0^2))$$

Lmax: Coasting distance of the machine [m]

V₀: Speed when the brake is activated [m/s]

M: Full mass of the moving part [kg]

A: Coefficient (Refer to the following tables.)

B: Coefficient (Refer to the following tables.)

Linear servo motor	Coefficient A	Coefficient B
LM-H3P2A-07P-BSS0	7.15E-03	2.94E-03
LM-H3P3A-12P-CSS0	2.81E-03	1.47E-03
LM-H3P3B-24P-CSS0	7.69E-03	2.27E-04
LM-H3P3D-48P-CSS0	1.02E-03	2.54E-04
LM-H3P7A-24P-ASS0	7.69E-03	2.14E-04

Linear servo motor	Coefficient A	Coefficient B
LM-U2PAB-05M-0SS0	5.72×10^{-2}	1.72×10^{-4}
LM-U2PAD-10M-0SS0	2.82×10^{-2}	8.60×10^{-5}
LM-U2PAF-15M-0SS0	1.87×10^{-2}	5.93×10^{-5}
LM-U2PBB-07M-1SS0	3.13×10^{-2}	1.04×10^{-4}
LM-U2PBD-15M-1SS0	1.56×10^{-2}	5.18×10^{-5}
LM-U2PBF-22M-1SS0	4.58×10^{-2}	1.33×10^{-5}

Linear servo motor	Coefficient A	Coefficient B
LM-K2P1A-01M-2SS1	5.36×10^{-3}	6.56×10^{-3}
LM-K2P2A-02M-1SS1	2.49×10^{-2}	1.02×10^{-3}

CAUTION

- The coasting distance is a theoretically calculated value which ignores the running load such as friction. The calculated value is considered to be longer than the actual distance. However, if an enough breaking distance is not obtained, the linear servo motor may crash into the stroke end, which is very dangerous. Install the anti-crash mechanism such as an air brake or an electric/mechanical stopper such as a shock absorber to reduce the shock of moving parts. No linear servo motor with an electromagnetic brake is available.

14. USING A LINEAR SERVO MOTOR

14.4.4 Permissible load to motor mass ratio when the dynamic brake is used

Use the dynamic brake under the load to motor mass ratio indicated in the following table. If the load to motor mass ratio is higher than this value, the dynamic brake may burn. If there is a possibility that the load inertia moment may exceed the value, contact your local sales office.

The values of the permissible load to motor mass ratio in the table are the values when the linear servo motor is used at the maximum speed.

Linear servo motor	Permissible load to motor mass ratio [multiplier]
LM-H3 series	40
LM-U2 series	100
LM-K2 series	50

When actual speed does not reach the maximum speed of the servo motor, calculate the permissible load to motor mass ratio at the time of using the dynamic brake by the following equation. (The upper limit is 300 times.)

Permissible load to motor mass ratio at the time of using the dynamic brake = Value in the table × (Servo motor maximum speed²/Actual using speed²)

For example, when an actual using speed is 2 m/s or less for the LM-H3P2A-07P motor (maximum speed: 3.0 m/s), the equation will be as follows. Permissible load to motor mass ratio at the time of using the dynamic brake = $40 \times 3^2/2^2 = 90$ [times]

15. USING A DIRECT DRIVE MOTOR

15. USING A DIRECT DRIVE MOTOR

 **CAUTION** ● When using the direct drive motor, read the "Direct Drive Motor Instruction Manual".

15.1 Functions and configuration

15.1.1 Summary

The fields of semiconductor/LCD manufacturing systems, mounters, and others have strong demands for high accuracy and efficiency. Therefore, the number of systems using a direct drive motor for a drive axis has been increasing. The direct drive servo system includes the following features.

(1) Performance

- (a) The direct drive servo system ensures the high-rigidity and the high-torque. A high-resolution encoder enables the high-accuracy control.
- (b) The high-resolution encoder contributes to the high-indexer accuracy.
- (c) Since transmission mechanism is no longer required, no backlash occurs. In addition, the settling time is reduced, and the high-frequency operation is enabled.
- (d) Since transmission mechanism is no longer required, the direct drive motor does not deteriorate with time.

(2) Mechanism

- (a) The motor's low profile design contributes to compact moving part of the machine and a low center of gravity for enhanced equipment stability.
- (b) The motor has an inner rotor with hollow shaft which enables cables and pipes to be passed through.
- (c) Lubrication and the maintenance due to abrasion are not required.

The following shows the differences between the direct drive motor and the rotary servo motor.

Category	Item	Differences		Remarks
		Direct drive motor	Rotary servo motor	
External I/O signal	FLS (Upper stroke limit), RLS (Lower stroke limit)	Required (for magnetic pole detection)	Not required	Automatically turns on in the parameter setting.
Motor pole adjustment	Magnetic pole detection	Required	Not required (default setting)	Automatically executed at the first servo-on after the power is turned on. For the absolute position detection system, [Pr. PL01] can disable the magnetic pole detection. (Refer to (3) (b) of 15.3.2.)
Absolute position detection system	Absolute position encoder battery 1 battery case (MR-BT6VCASE) and 5 batteries (MR-BAT6V1)	Required	Required	/
	Absolute position storage unit (MR-BTAS01)	Required	Not required	

15. USING A DIRECT DRIVE MOTOR

15.1.2 Servo system with auxiliary equipment

CAUTION ●Connecting a direct drive motor for different axis to the CNP3A, CNP3B, or CNP3C connector may cause a malfunction.

POINT

- Equipment other than the servo amplifier and direct drive motor are optional or recommended products.
- When using the direct drive motor, set [Pr. PA01] to " __ 6 __".

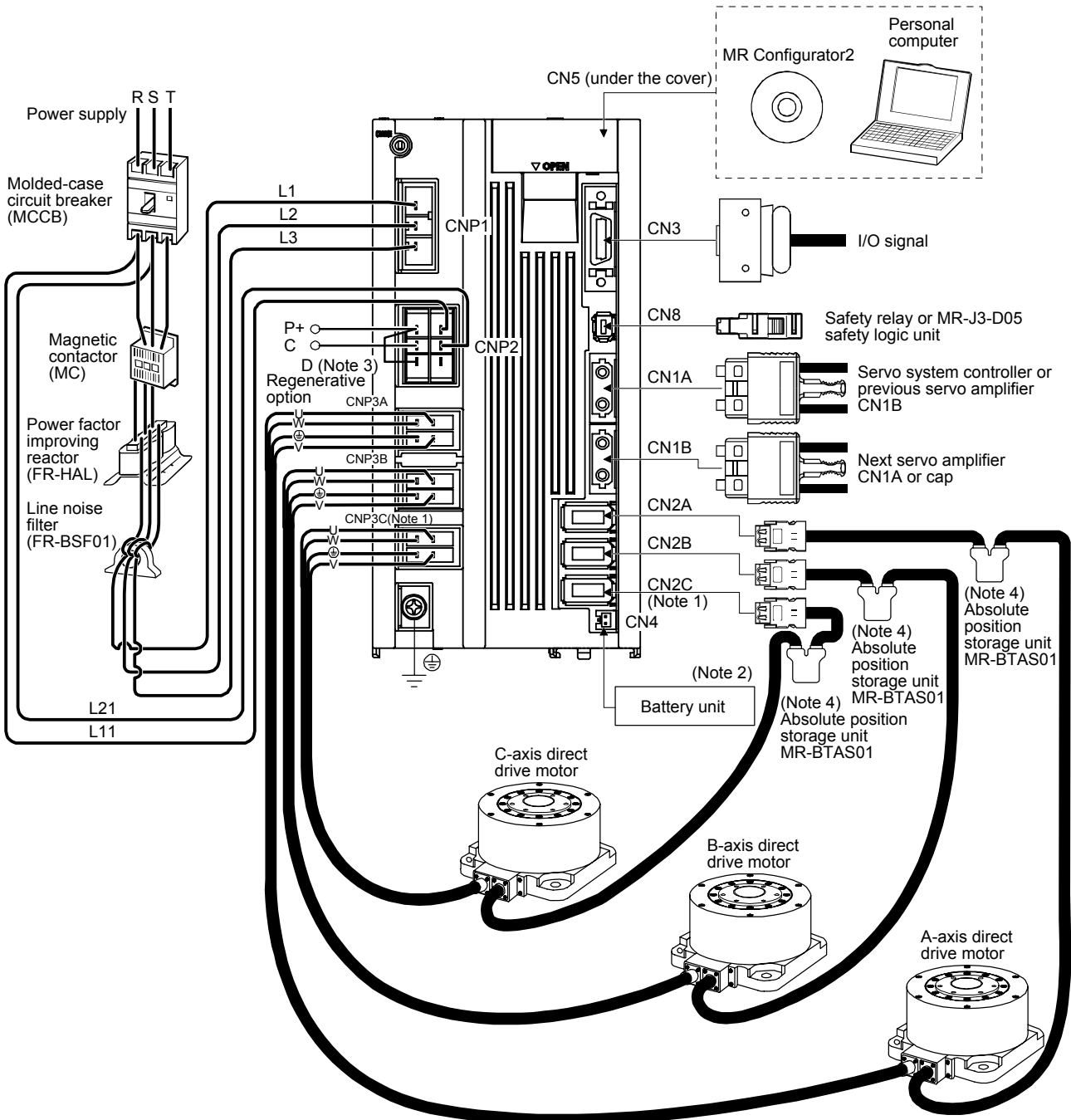

15. USING A DIRECT DRIVE MOTOR

- Note
1. This figure shows the 3-axis servo amplifier.
 2. The battery unit consists of a battery case (MR-BT6VCASE) and up to 5 batteries (MR-BAT6V1). The battery unit is used in the absolute position detection system. (Refer to chapter 12.)
 3. Always connect P+ and D. When using the regenerative option, refer to section 11.2.
 4. The absolute position storage unit is used for the absolute position detection system.

15.2 Signals and wiring



WARNING

- Any person who is involved in wiring should be fully competent to do the work.
- Before wiring, turn off the power and wait for 15 minutes or more until the charge lamp turns off. Then, confirm that the voltage between P+ and N- is safe with a voltage tester and others. Otherwise, an electric shock may occur. In addition, when confirming whether the charge lamp is off or not, always confirm it from the front of the servo amplifier.
- Ground the servo amplifier and the direct drive motor securely.
- Do not attempt to wire the servo amplifier and the direct drive motor until they have been installed. Otherwise, it may cause an electric shock.
- The cables should not be damaged, stressed, loaded, or pinched. Otherwise, it may cause an electric shock.
- To avoid an electric shock, insulate the connections of the power supply terminals.

- Wire the equipment correctly and securely. Otherwise, the direct drive motor may operate unexpectedly, resulting in injury.
- Connect cables to the correct terminals. Otherwise, a burst, damage, etc. may occur.
- Ensure that polarity (+/-) is correct. Otherwise, a burst, damage, etc. may occur.
- The surge absorbing diode installed to the DC relay for control output should be fitted in the specified direction. Otherwise, the emergency stop and other protective circuits may not operate.

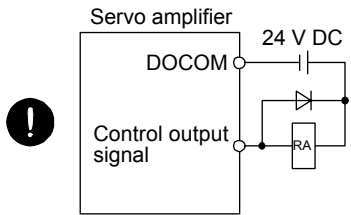

For sink output interface

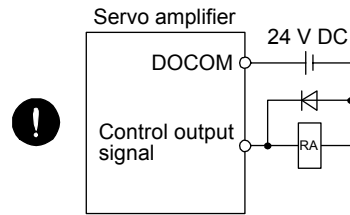

For source output interface



CAUTION

- Use a noise filter, etc. to minimize the influence of electromagnetic interference. Electromagnetic interference may be given to the electronic equipment used near the servo amplifier.
- Do not install a power capacitor, surge killer, or radio noise filter (FR-BIF option) with the power wire of the direct drive motor.
- When using the regenerative resistor, switch power off with the alarm signal. Otherwise, a transistor fault or the like may overheat the regenerative resistor, causing a fire.
- Do not modify the equipment.
- During power-on, do not open or close the power line of the direct drive motor. Otherwise, it may cause a malfunction.

15. USING A DIRECT DRIVE MOTOR

CAUTION !

- Connect the servo amplifier power output (U, V, and W) to the power input of the direct drive motor (U, V, and W) directly. Do not let a magnetic contactor, etc. intervene. Otherwise, it may cause a malfunction.

- Connecting a servo motor for different axis to the CNP3A, CNP3B, or CNP3C connector may cause a malfunction.

This chapter does not describe the following items. For details of the items, refer to each section of the detailed description field.

Item	Detailed explanation
Input power supply circuit	Section 3.1
Explanation of power supply system	Section 3.3
Signal (device) explanations	Section 3.5
Alarm occurrence timing chart	Section 3.7
Interfaces	Section 3.8
SSCNET III cable connection	Section 3.9
Grounding	Section 3.11
Switch setting and display of the servo amplifier	Section 4.3
Parameters	Chapter 5
Troubleshooting	Chapter 8

15.3 Operation and functions

POINT

- When using the direct drive motor, set [Pr. PA01] to " __ 6 _".
- For the test operation, refer to section 4.4.
- The Z-phase pulse of the direct drive motor must be turned on after power-on. When the machine configuration does not allow one or more revolution of the direct drive motor, install the direct drive motor so that the Z-phase pulse can be turned on.

15. USING A DIRECT DRIVE MOTOR

15.3.1 Startup procedure

Start up the direct drive servo in the following procedure.

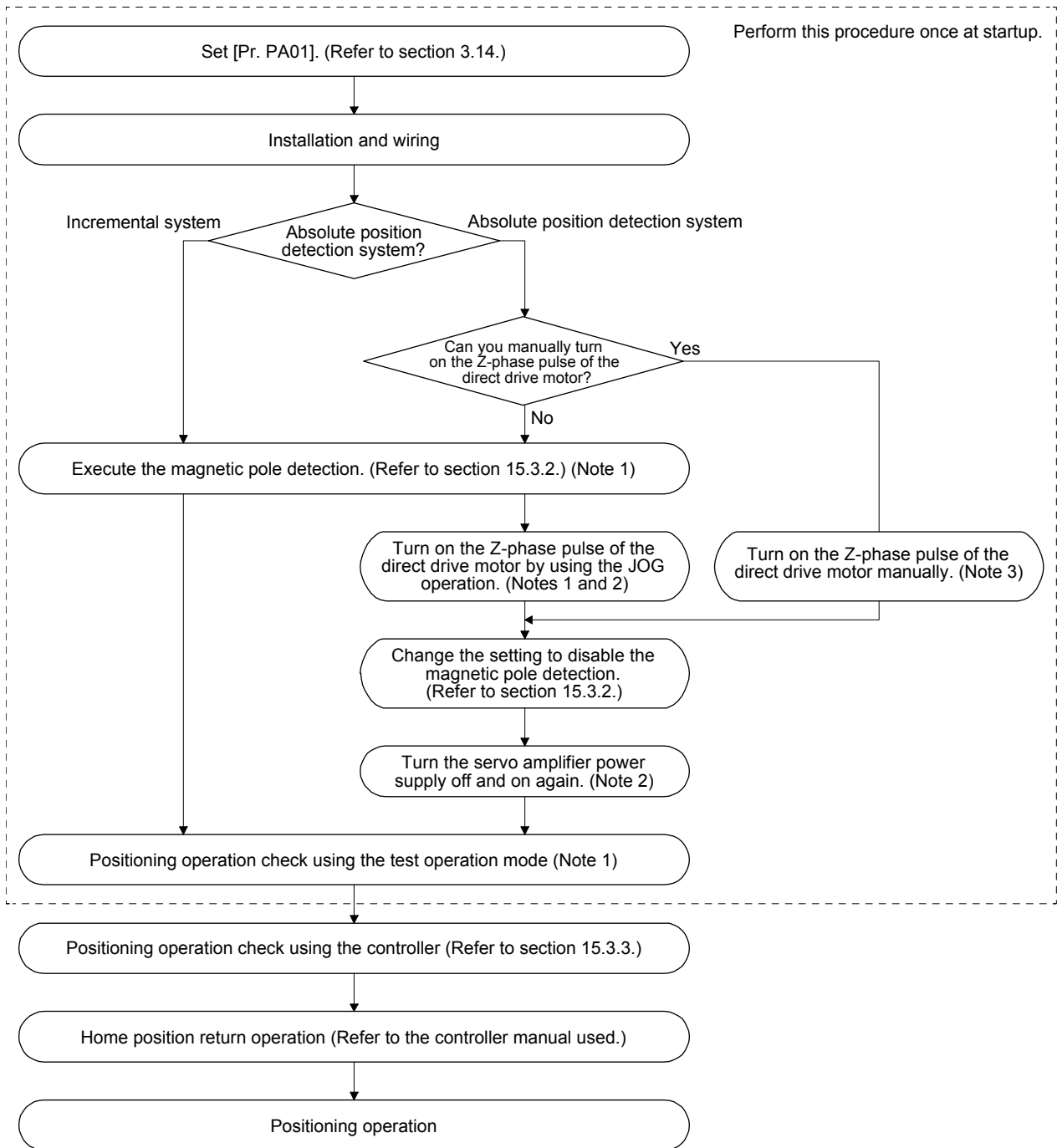

Note 1. Use MR Configurator2.

2. For the absolute position detection system, always turn on the Z-phase pulse of the direct drive motor while the servo amplifier power is on, and then turn the servo amplifier power supply off and on again. By turning off and on the power supply, the absolute position becomes confirmed. Without this operation, the absolute position will not be regained properly, and a warning will occur at the controller.

3. If the Z-phase pulse of the direct drive motor can be turned on manually, the Z-phase pulse does not have to be turned on by the magnetic pole detection or the JOG operation.

For this operation, always connect the direct drive motor encoder and the servo amplifier, and turn on only the control circuit power supply of the servo amplifier (L11 and L21) (turn off the main circuit power supply L1, L2, and L3). Perform this operation by considering the safety.

15. USING A DIRECT DRIVE MOTOR

15.3.2 Magnetic pole detection

POINT
<ul style="list-style-type: none">● The magnetic pole detection is not required for the configured absolute position detection system where the Z-phase pulse of the direct drive motor can be turned on manually. For this operation, always connect the direct drive motor encoder and the servo amplifier and turn on the control circuit power supply of the servo amplifier. Perform this operation by considering the safety.

Before the positioning operation of the direct drive motor, make sure to perform the magnetic pole detection.
Before starting up the equipment, perform the test operation (positioning operation) of MR Configurator2.

15. USING A DIRECT DRIVE MOTOR

(1) Magnetic pole detection method by using MR Configurator2

The following shows the magnetic pole detection procedure by using MR Configurator2.

(a) Magnetic pole detection by the position detection method

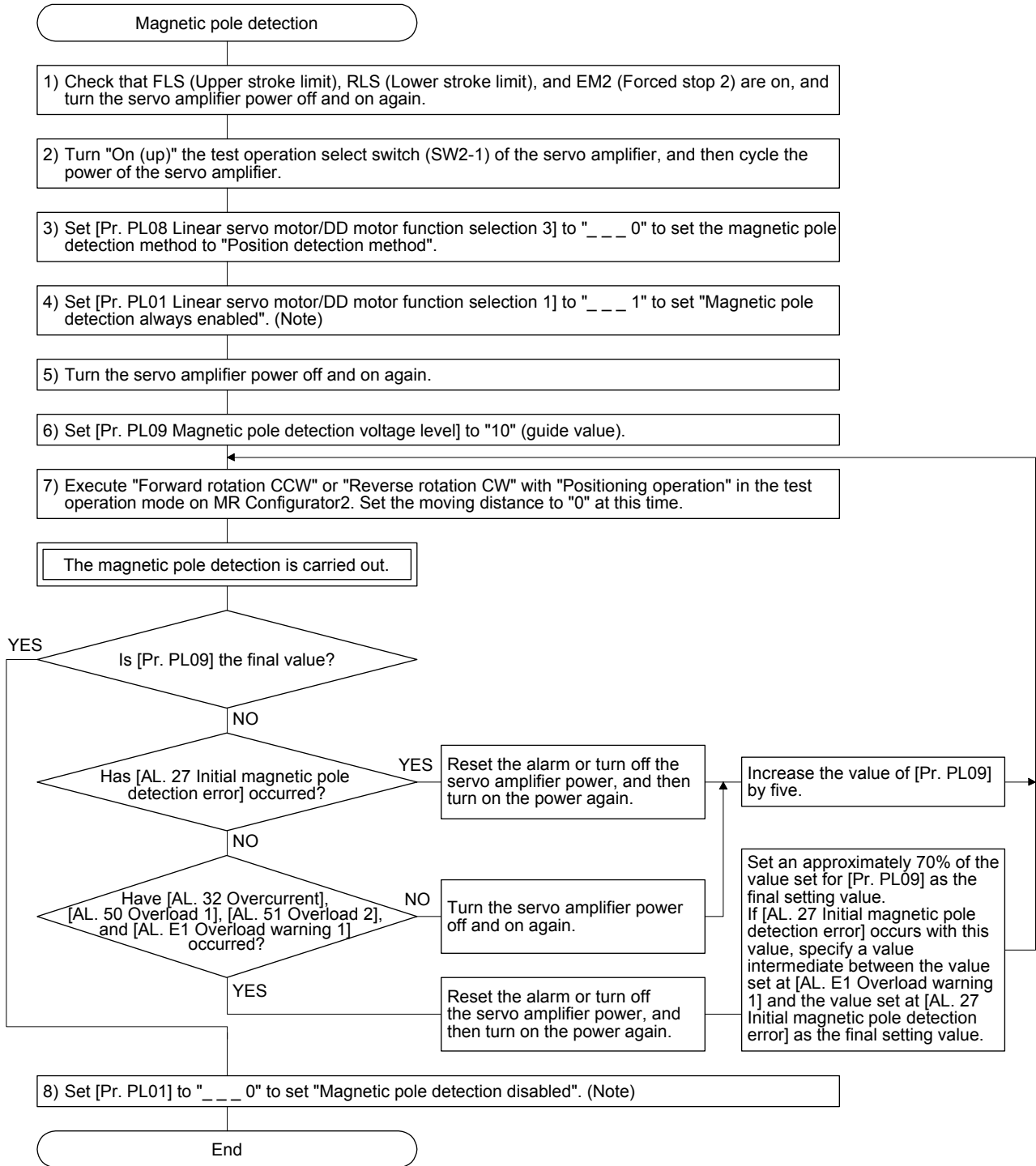

Note. For the incremental system, the [Pr. PL01] setting is not required.

15. USING A DIRECT DRIVE MOTOR

(b) Magnetic pole detection by the minute position detection method

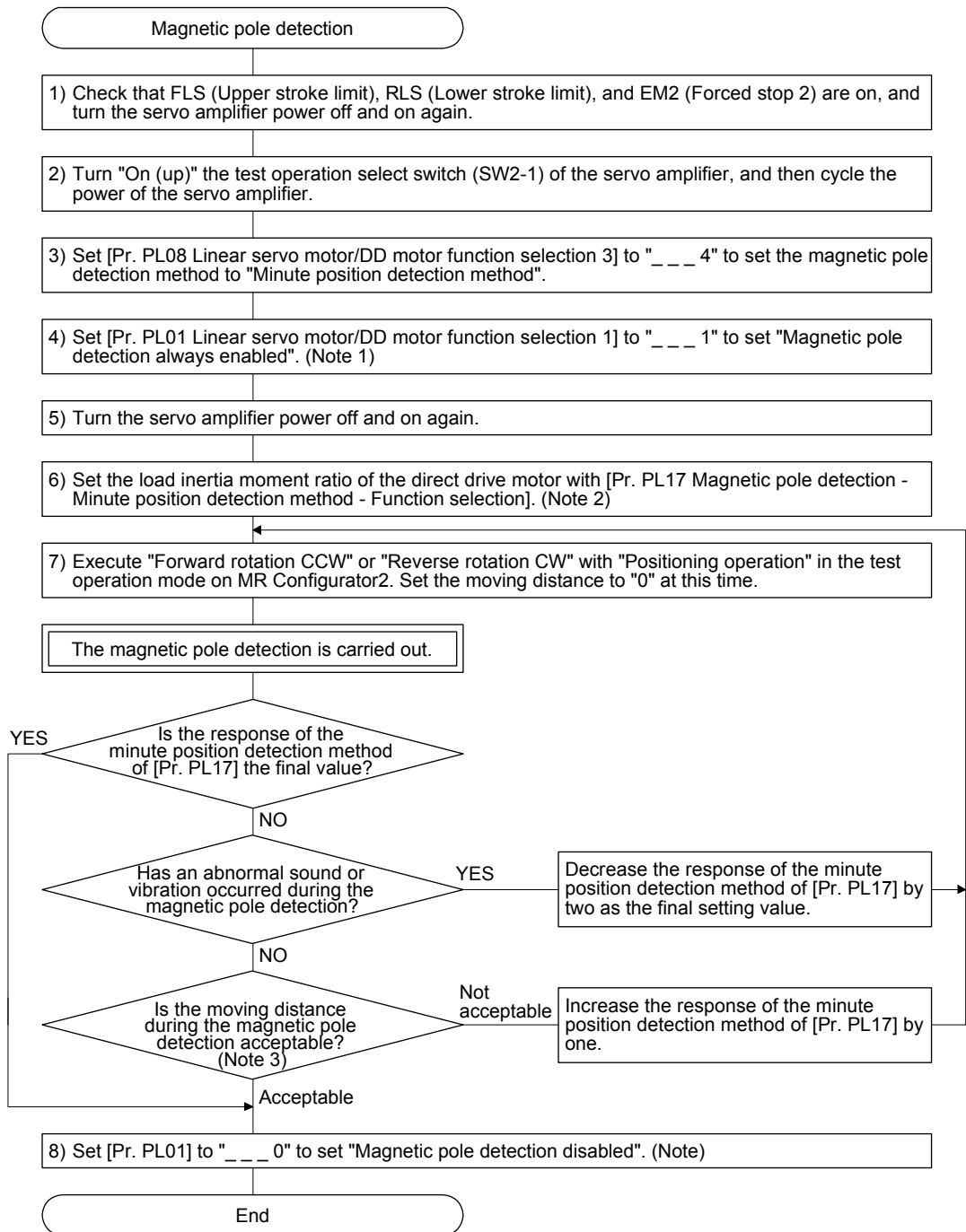

- Note
1. For the incremental system, the [Pr. PL01] setting is not required.
 2. If the load to direct drive motor inertia ratio is unknown, perform the magnetic pole detection by the position detection method, and then perform the auto tuning to set an estimated value.
 3. For the magnetic pole detection by the minute position detection method, the maximum rotation angle at the magnetic pole detection must be five degrees or less. To shorten the travel distance, increase the response by the minute position detection method in [Pr. PL17].

15. USING A DIRECT DRIVE MOTOR

- (c) State transition of the servo amplifier display (3-digit, 7-segment LED) at the magnetic pole detection
 When the magnetic pole detection with MR Configurator2 is normally executed, the servo amplifier display (3-digit, 7-segment LED) shows the state as below.

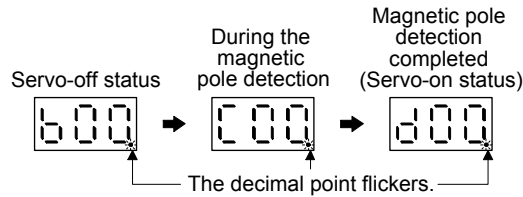

- (2) Preparation for the magnetic pole detection

POINT
<ul style="list-style-type: none"> ● When the test operation mode is selected with the test operation select switch (SW2-1), the SSCNET III/H communication for the servo amplifier in the test operation mode and the following servo amplifiers is blocked.

For the magnetic pole detection, use the test operation mode (positioning operation) of MR Configurator2. Turn off the servo amplifier power, and set the test operation select switch (SW2-1) and the disabling control axis switch (SW2-2, SW2-3, and SW2-4) as shown below. Turning on the power enables the test operation mode.

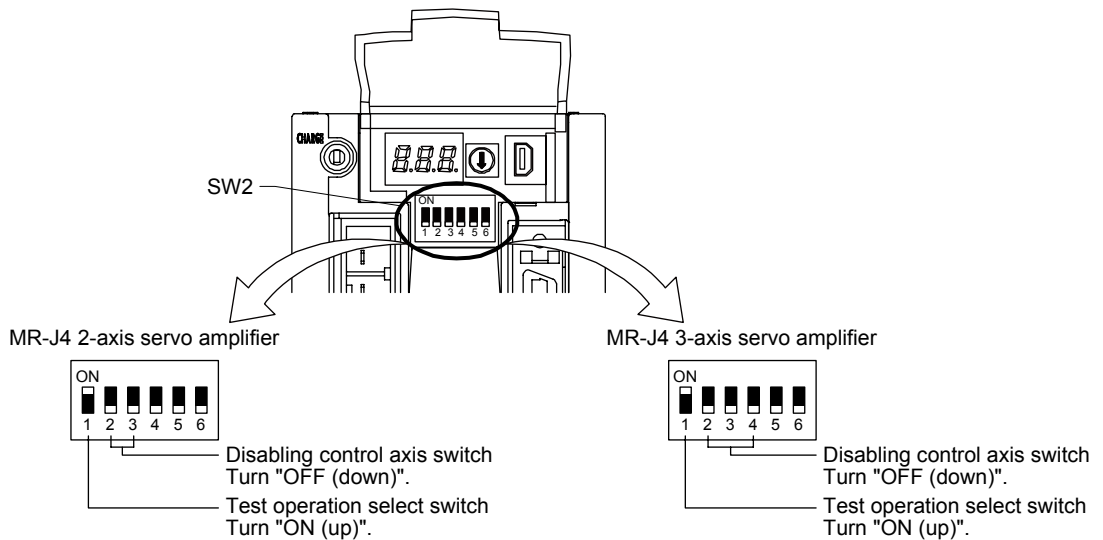

15. USING A DIRECT DRIVE MOTOR

(3) Operation at the magnetic pole detection

! WARNING ● Note that the magnetic pole detection automatically starts simultaneously with the turning-on of the servo-on command.

! CAUTION ● If the magnetic pole detection is not executed properly, the direct drive motor may operate unexpectedly.

POINT
<ul style="list-style-type: none"> ● Establish the machine configuration using FLS (Upper stroke limit) and RLS (Lower stroke limit). Otherwise, the machine may be damaged due to a collision. ● At the magnetic pole detection, whether the motor rotates in the forward or reverse direction is unpredictable. ● Depending on the setting value of [Pr. PL09 Magnetic pole detection voltage level], an overload, overcurrent, magnetic pole detection alarm, or others may occur. ● When performing the positioning operation from a controller, use the sequence which confirms the normal completion of the magnetic pole detection and the servo-on status, then outputs the positioning command. If the controller outputs the positioning command before RD (Ready) turns on, the command may not be accepted or a servo alarm may occur. ● After the magnetic pole detection, check the positioning accuracy with the test operation (positioning operation function) of MR Configurator2. ● The accuracy of the magnetic pole detection improves with no load.

(a) Incremental system

POINT
<ul style="list-style-type: none"> ● For the incremental system, the magnetic pole detection is required every time the power is turned on.

By turning on the servo-on command from the controller after the power-on, the magnetic pole detection is automatically carried out. Therefore, there is not need to set the parameter (first digit of [Pr. PL01]) for executing the magnetic pole detection.

1) Timing chart

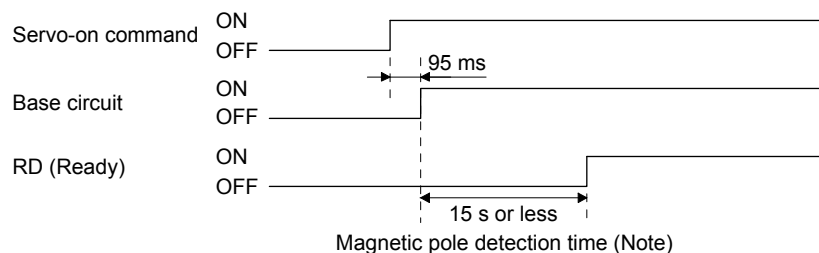

Note. The magnetic pole detection time indicates the operation time when FLS (Upper stroke limit) and RLS (Lower stroke limit) are on.

15. USING A DIRECT DRIVE MOTOR

2) Direct drive motor movement (when FLS and RLS are on)

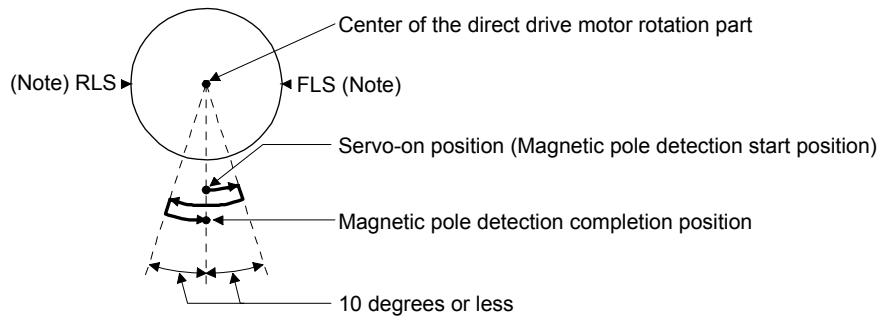

Note. When the stroke limit (FLS or RLS) turns off during the magnetic pole detection, the magnetic pole detection is carried on to the opposite direction. When FLS and RLS are off, [AL. 27 Initial magnetic pole detection error] occurs.

3) Direct drive motor movement (when FLS or RLS is off)

When FLS or RLS is off at servo-on, the magnetic pole detection is carried out as follows.

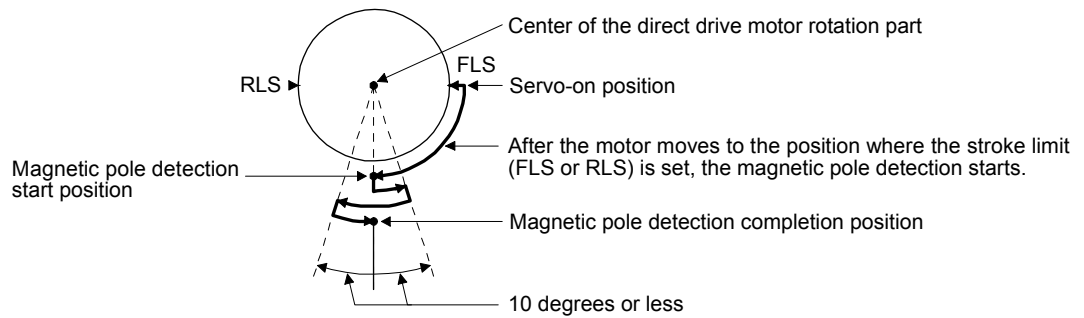

(b) Absolute position detection system

POINT
<ul style="list-style-type: none"> ● When the absolute position detection system is used, the magnetic pole detection is required when the power is turned on with the following timing. <ul style="list-style-type: none"> ▪ When the system is set up (at the first startup of equipment) ▪ When the Z-phase pulse of the direct drive motor is not turned on at the system setup (When the Z-phase pulse of the direct drive motor can be turned on manually, the magnetic pole detection is not required.) ▪ After a direct drive motor is replaced ▪ When [AL. 25 Absolute position erased] has occurred ● Turn on the Z-phase pulse of the direct drive motor in JOG operation from the controller after the magnetic pole detection.

Perform the magnetic pole detection in the following procedure.

- 1) Set [Pr. PL01 Linear servo motor/DD motor function selection 1] to " __ _ 1" (Magnetic pole detection at first servo-on).

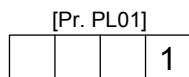

Magnetic pole detection at first servo-on (initial value)

15. USING A DIRECT DRIVE MOTOR

- 2) Execute the magnetic pole detection. (Refer to (2) (a) 1), 2) of this section.)
- 3) After the completion of the magnetic pole detection, change [Pr. PL01] to "___0" (Magnetic pole detection disabled).

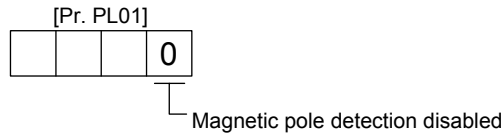

After the magnetic pole detection, by turning on the Z-phase pulse of the direct drive motor in JOG operation and by disabling the magnetic pole detection function with [Pr. PL01], the magnetic pole detection after each power-on is not required.

(4) Magnetic pole detection method setting

Set the magnetic pole detection method using the first digit of [Pr. PL08] (Magnetic pole detection method selection).

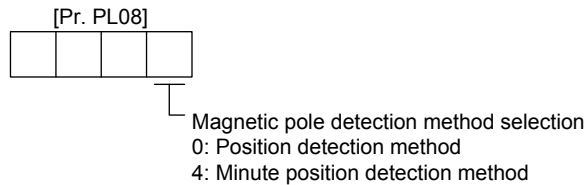

(5) Setting of the magnetic pole detection voltage level by the position detection method

For the magnetic pole detection by the position detection method, set the voltage level with [Pr. PL09 Magnetic pole detection voltage level]. For the magnetic pole detection by the minute position detection method, the voltage level setting is not required.

(a) Guideline of parameter settings

Set the parameters by referring to the following table.

[Pr. PL09] setting (Guide value)	Small ← Medium → Large (10 or less (initial value) 50 or more)	
Servo status		
Torques required for operation	Small	Large
Overload, overcurrent alarm	Seldom occurs	Frequently occurs
Magnetic pole detection alarm	Frequently occurs	Seldom occurs
Magnetic pole detection accuracy	Low	High

(b) Setting procedure

- 1) Perform the magnetic pole detection, and increase the setting value of [Pr. PL09 Magnetic pole detection voltage level] until [AL. 50 Overload 1], [AL. 51 Overload 2], [AL. E1 Overload warning 1], and [AL. EC Overload warning 2] occur. Increase the setting value by five as a guide value. When these alarms and warnings occur during the magnetic pole detection by using MR Configurator2, the test operation of MR Configurator2 automatically completes and the servo-off status is established.

15. USING A DIRECT DRIVE MOTOR

- 2) Specify the setting value that is an approximately 70% of the value set when [AL. 50 Overload 1], [AL. 51 Overload 2], [AL. E1 Overload warning 1], and [AL. EC Overload warning 2] occurred as the final setting value. However, if [AL. 27 Initial magnetic pole detection error] occurs with this value, specify a value intermediate between the value set at [AL. 50 Overload 1], [AL. 51 Overload 2], [AL. E1 Overload warning 1], or [AL. EC Overload warning 2] and the value set at the magnetic pole detection alarm as the final setting value.
- 3) Perform the magnetic pole detection again with the final setting value.

(c) Setting example

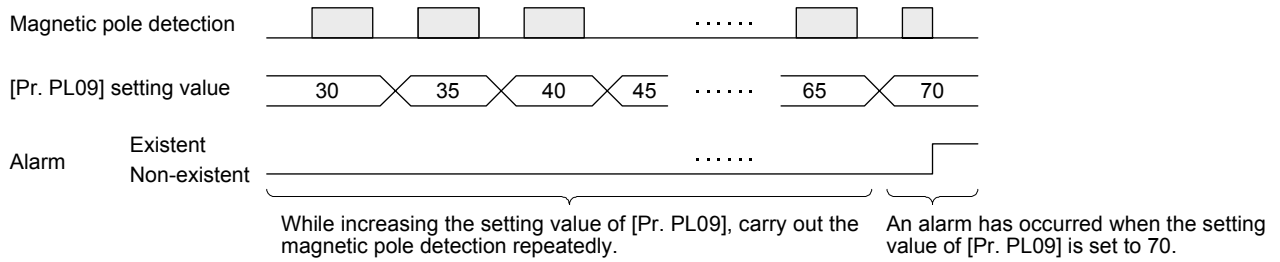

In this example, the final setting value of [Pr. PL09] is 49 (Setting value at the alarm occurrence = 70×0.7).

15. USING A DIRECT DRIVE MOTOR

15.3.3 Operation from controller

To configure the absolute position detection system by using the direct drive motor, the battery unit (one battery case (MR-BT6VCASE) and five batteries (MR-BAT6V1)) and the absolute position storage unit (MR-BTAS01) are required.

(1) Operation method

For the incremental system, the magnetic pole detection is automatically performed at the first servo-on after the power-on. For this reason, when performing the positioning operation, create the sequence which surely confirms the servo-on status as the inter lock condition of the positioning command. Also, some parameter settings and the home position return differ according to the controller type.

(2) Servo system controller setting

The following parameters will be enabled by cycling the servo amplifier power after the controller writes the parameters to the servo amplifier.

Setting item					Set content	
					Motion controller Q17_DSCPU	Simple motion module QD77MS_
Parameter	Servo amplifier setting				MR-J4-B DD	
	Motor setting				Automatic setting	
	No.	(Note) Symbol	Name	Initial value	Set the items as required.	
	PA01	**STY	Operation mode	1000h		
	PC01	*ERZ	Error excessive alarm level	0		
	PC03	*ENRS	Encoder output pulse selection	0000h		
	PL01	**LIT1	Linear servo motor/DD motor function selection 1	0301h		
	PL04	*LIT2	Linear servo motor/DD motor function selection 2	0003h		
	PL05	LB1	Position deviation error detection level	0		
	PL06	LB2	Speed deviation error detection level	0		
	PL07	LB3	Torque/thrust deviation error detection level	100		
	PL08	*LIT3	Linear servo motor/DD motor function selection 3	0010h		
	PL09	LPWM	Magnetic pole detection voltage level	30		
	PL17	LTSTS	Magnetic pole detection - Minute position detection method - Function selection	0000h		
	PL18	IDLV	Magnetic pole detection - Minute position detection method - Identification signal amplitude	0		

Note. The parameter whose symbol is preceded by * is enabled with the following conditions:

* : After setting the parameter, power off and on the servo amplifier or reset the controller.

** : After setting the parameter, cycle the power of the servo amplifier.

15. USING A DIRECT DRIVE MOTOR

15.3.4 Function

(1) Servo control error detection function

POINT
<p>● For the servo control error detection function, the position and speed deviation error detections are enabled by default. ([Pr. PL04]: __ _ 3)</p>

If the servo control gets unstable for some reasons, the direct drive motor may not operate properly. To detect this state and to stop operation, the servo control error detection function is used as a protective function.

The servo control error detection function has three different detection methods: the position deviation, speed deviation, and torque deviation. An error is detected when each method is enabled with [Pr. PL04 Linear servo motor/DD motor function selection 2]. The detection level can be changed with [Pr. PL05], [Pr. PL06], and [Pr. PL07].

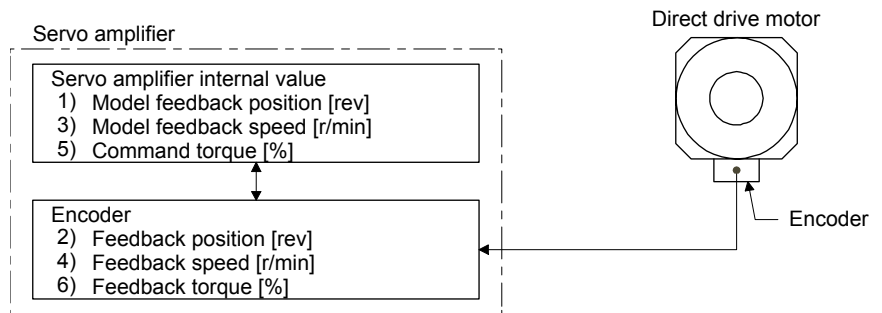
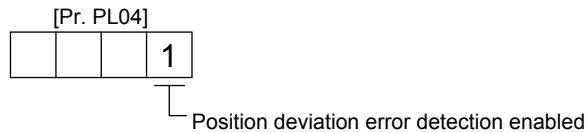

Figure 15.1 Outline of servo control error detection function

(a) Position deviation error detection

Set [Pr. PL04] to "__ _ 1" to enable the position deviation error detection.



When you compare the model feedback position (1)) and the feedback position (2)) in figure 15.1, if the deviation is more than the value of [Pr. PL05 Position deviation error detection level] (1 (0.01 rev) to 1000 (10 rev)), [AL. 42.1 Servo control error by position deviation] will occur and the linear servo motor will stop. The initial value of this detection level is 0.09 rev. Replace the set value as required.

15. USING A DIRECT DRIVE MOTOR

(b) Speed deviation error detection

Set [Pr. PL04] to "___2" to enable the speed deviation error detection.

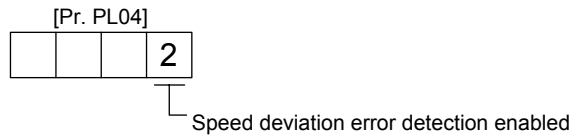

When you compare the model feedback speed (3) and the feedback speed (4) in figure 15.1, if the deviation is more than the value of [Pr. PL06 Speed deviation error detection level] (1 r/min to 2000 r/min), [AL. 42.2 Servo control error by speed deviation] will occur and the linear servo motor will stop. The initial value of this detection level is 100 r/min. Replace the set value as required.

(c) Torque deviation error detection level

Set [Pr. PL04] to "___4" to enable the torque deviation error detection.

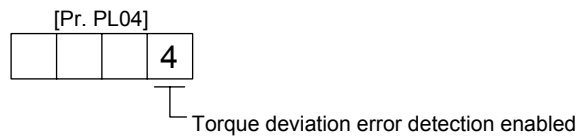

When you compare the command torque (5) and the feedback torque (6) in figure 15.1, if the deviation is more than the value of [Pr. PL07 Torque/thrust deviation error detection level] (1% to 1000%), [AL. 42.3 Servo control error by torque/thrust deviation] will occur and the linear servo motor will stop. The initial value of this detection level is 100%. Replace the set value as required.

(d) Detecting multiple deviation errors

When setting [Pr. PL04] as shown below, multiple deviation errors can be detected. For the error detection methods, refer to (1) (a), (b), (c) of this section.

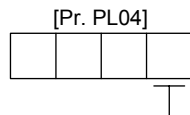

Setting value	Position deviation error detection	Speed deviation error detection	Torque deviation error detection
1	○	○	○
2	○	○	○
3	○	○	○
4	○	○	○
5	○	○	○
6	○	○	○
7	○	○	○

15. USING A DIRECT DRIVE MOTOR

15.4 Characteristics

15.4.1 Overload protection characteristics

An electronic thermal relay is built in the servo amplifier to protect the servo amplifier, the direct drive motor, and direct drive motor power wires from overloads.

[AL. 50 Overload 1] occurs if overload operation performed is above the electronic thermal protection curve shown in fig. 15.2. [AL. 51 Overload 2] occurs if the maximum current is applied continuously for several seconds due to machine collision, etc. Use the equipment on the left-side area of the continuous or broken line in the graph.

When unbalanced torque is generated, such as in a vertical lift machine, it is recommended that the unbalanced torque of the machine be kept at 70% or less of the motor's rated torque.

This servo amplifier has solid-state direct drive motor overload protection for each axis. (The direct drive motor overload current (full load current) is set on the basis of 120% rated current of the servo amplifier.)

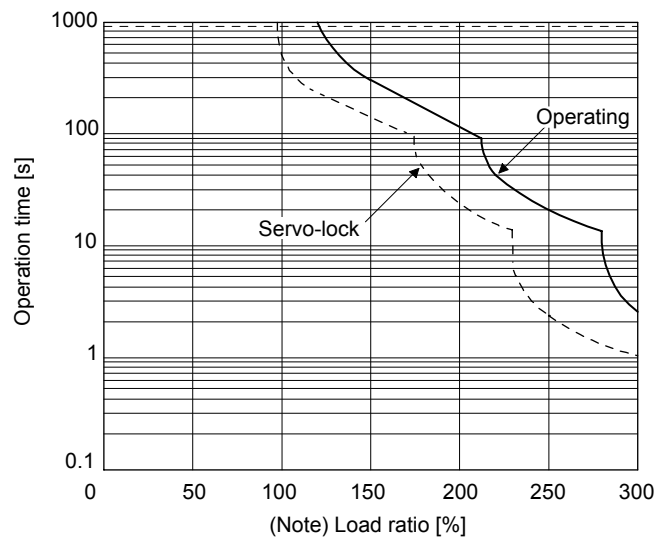

TM-RFM002C20, TM-RFM004C20, TM-RFM006C20
TM-RFM006E20, TM-RFM012E20, TM-RFM018E20
TM-RFM012G20
TM-RFM040J10

Note. If operation that generates torque more than 100% of the rating is performed with an abnormally high frequency in a direct drive motor stop status (servo-lock status) or in a 30 r/min or less low-speed operation status, the servo amplifier may malfunction regardless of the electronic thermal relay protection.

Fig. 15.2 Electronic thermal protection characteristics

15. USING A DIRECT DRIVE MOTOR

15.4.2 Power supply capacity and generated loss

Calculate the generated loss and the power supply capacity of the servo amplifier under rated load from (1) and (2) in this section. The calculated value will vary depending on the number of connected direct drive motors and the capacities of the direct drive motors. For thermal design of an enclosed type cabinet, use the values calculated in consideration for the worst operating conditions. The actual amount of generated heat will be intermediate between values at rated torque and servo-off according to the duty used during operation. When the direct drive motor is run at less than the rated speed, the power supply capacity will be smaller than the calculated value, but the servo amplifier's generated heat will not change.

(1) Calculation method of power supply capacity

Calculate the power supply capacity for one servo amplifier from tables 15.1 and 15.2.

Table 15.1 Power supply capacity for one servo amplifier at rated output

Servo amplifier	(Note) Power supply capacity [kVA]
MR-J4W2-22B	Total power supply capacity of connected direct drive motors ((A) in table 15.2)
MR-J4W2-44B	
MR-J4W2-77B	
MR-J4W2-1010B	
MR-J4W3-222B	
MR-J4W3-444B	

Note. Note that the power supply capacity will vary according to the power supply impedance. This value is applicable when the power factor improving reactor is not used.

Table 15.2 Servo amplifier power supply capacity for one direct drive motor

Servo motor	Power supply capacity [kVA] (A)
TM-RFM002C20	0.25
TM-RFM004C20	0.38
TM-RFM006C20	0.53
TM-RFM006E20	0.46
TM-RFM012E20	0.81
TM-RFM018E20	1.3
TM-RFM012G20	0.71
TM-RFM040J10	1.2

Calculate the power supply capacity with equation 10.1 in (1) in section 10.2.

(2) Calculation method of the amount of heat generated by the servo amplifier

Calculate the amount of heat generated by one servo amplifier from tables 15.3 and 15.4.

Table 15.3 Amount of heat generated by one servo amplifier at rated output

Servo amplifier	(Note) Servo amplifier-generated heat [W]	
	With servo-off (C)	At rated output
MR-J4W2-22B	20	Sum of the total amount of heat generated by the servo amplifier for each direct drive motor ((B) in table 15.4) and the amount of heat generated by the servo amplifier with servo-off (C)
MR-J4W2-44B	20	
MR-J4W2-77B	20	
MR-J4W2-1010B	20	
MR-J4W3-222B	20	
MR-J4W3-444B	25	

Note. Heat generated during regeneration is not included in the servo amplifier-generated heat. To calculate heat generated by the regenerative option, refer to section 11.2.

Table 15.4 Amount of heat generated by one servo amplifier for one direct drive motor

Servo motor	Servo amplifier-generated heat [W] (B)
TM-RFM002C20	25
TM-RFM004C20	35
TM-RFM006C20	40
TM-RFM006E20	40
TM-RFM012E20	50
TM-RFM018E20	50
TM-RFM012G20	50
TM-RFM040J10	50

Calculate the amount of heat generated by the servo amplifier with equation 10.2 in (2) in section 10.2.

15. USING A DIRECT DRIVE MOTOR

15.4.3 Dynamic brake characteristics

POINT
<ul style="list-style-type: none"> ● Do not use dynamic brake to stop in a normal operation as it is the function to stop in emergency. ● For a machine operating at the recommended load to motor inertia ratio or less, the estimated number of usage times of the dynamic brake is 1000 times while the machine decelerates from the rated speed to a stop once in 10 minutes. ● Be sure to enable EM1 (Forced stop 1) after the direct drive motor stops when using EM1 (Forced stop 1) frequently in other than emergency.

(1) Dynamic brake operation

(a) Calculation of coasting distance

Fig. 15.3 shows the pattern in which the servo motor comes to a stop when the dynamic brake is operated. Use equation 15.1 to calculate an approximate coasting distance to a stop. The dynamic brake time constant τ varies with the direct drive motor and machine operation speeds. (Refer to (1) (b) of this section.)

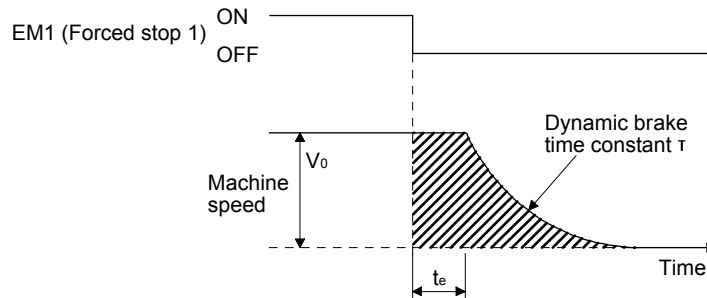

Fig. 15.3 Dynamic brake operation diagram

$$L_{\max} = \frac{V_0}{60} \cdot \left\{ t_e + \tau \left(1 + \frac{J_L}{J_M} \right) \right\} \dots\dots\dots (15.1)$$

- L_{\max} : Maximum coasting distance [mm]
- V_0 : Machine's fast feed speed [mm/min]
- J_M : Moment of inertia of direct drive motor [$\times 10^{-4}$ kg·m²]
- J_L : Load moment of inertia converted into equivalent value on direct drive motor rotor .. [$\times 10^{-4}$ kg·m²]
- τ : Dynamic brake time constant [s]
- t_e : Delay time of control section [s]

There is internal relay delay time of about 10 ms

15. USING A DIRECT DRIVE MOTOR

(b) Dynamic brake time constant

The following shows necessary dynamic brake time constant τ for the equation (15.1).

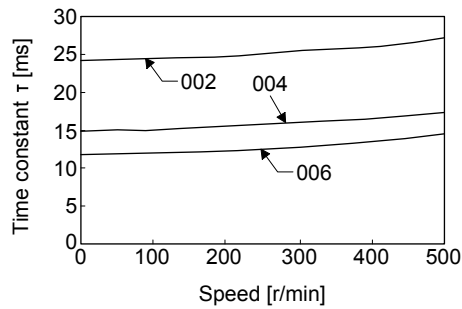

TM-RFM_C20

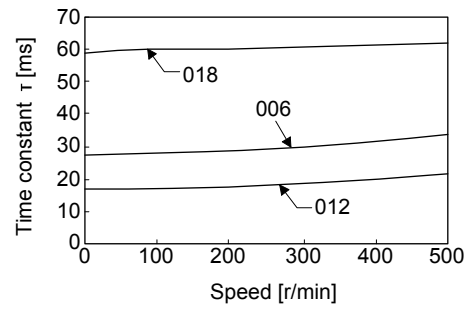

TM-RFM_E20

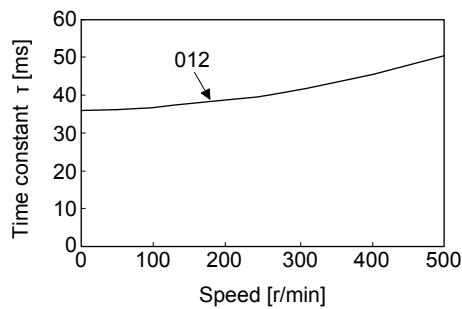

TM-RFM_G20

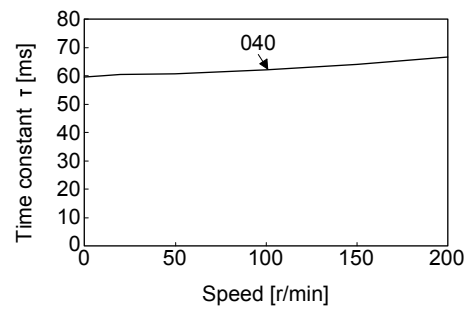

TM-RFM_J10

(2) Permissible load to motor inertia ratio when the dynamic brake is used

Use the dynamic brake under the load to motor inertia ratio indicated in the following table. If the load inertia moment is higher than this value, the dynamic brake may burn. If there is a possibility that the load inertia moment may exceed the value, contact your local sales office.

The values of the permissible load to motor inertia ratio in the table are the values at the maximum rotation speed of the direct drive motor.

The value in the parenthesis shows the value at the rated speed of the direct drive motor.

Direct drive motor	Permissible load to motor inertia ratio [multiplier]
TM-RFM_C20	100(300)
TM-RFM_E20	
TM-RFM_G20	50(300)
TM-RFM_J10	50(200)

16. FULLY CLOSED LOOP SYSTEM

16. FULLY CLOSED LOOP SYSTEM

POINT
<ul style="list-style-type: none"> ● The fully closed loop system is available for the MR-J4-W2-_B servo amplifiers of which software version is A3 or above. Check the software version using MR Configurator2. It will not be available with MR-J4W3-_B. ● When fully closed loop control system is used with this servo amplifier, "Linear Encoder Instruction Manual" is needed. ● Fully closed loop control system is available with position control mode. ● When fully closed loop control system is configured with MR-J4W2-_B servo amplifier, the following restrictions apply. <ul style="list-style-type: none"> ▪ A/B/Z-phase differential output type encoder cannot be used. ▪ The load-side encoder and servo motor encoder is compatible with only the two-wire type. The four-wire type load-side encoder and servo motor encoder cannot be used. ▪ When you use the KG-KR and HG-MR series for driving and load-side encoder, the optional four-wire type encoder cables (MR-EKCBL30M-L, MR-EKCBL30M-H, MR-EKCBL40M-H, and MR-EKCBL50M-H) cannot be used. When an encoder cable of 30 m to 50 m is needed, fabricate the encoder cable according to appendix 8.

16.1 Functions and configuration

16.1.1 Function block diagram

A fully closed loop control block diagram is shown below. The fully closed loop system is controlled in the load-side encoder unit.

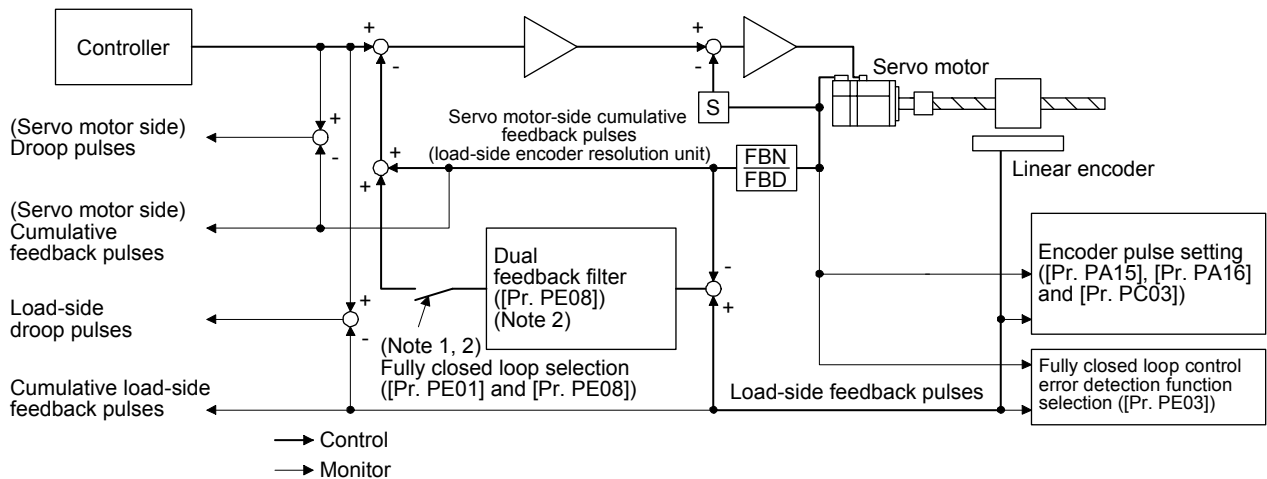

- Note 1. Switching between semi closed loop control and fully closed loop control can be performed by changing the setting of [Pr. PE01].
 When semi closed loop control is selected, a control is always performed on the bases of the position data of the servo motor encoder independently of whether the servo motor is at a stop or running.
- Note 2. When the fully closed loop system is enabled in [Pr. PE01], dual feedback control in which the servo motor feedback signal and load-side encoder feedback signal are combined by the dual feedback filter in [Pr. PE08] is performed.
 In this case, fully closed loop control is performed when the servo motor is at a stop, and semi closed loop control is performed when the servo motor is operating to improve control performance. When "4500" is set as the filter value of [Pr. PE08 Dual feedback filter], fully closed loop control is always performed.

16. FULLY CLOSED LOOP SYSTEM

The following table shows the functions of each control mode.

Control	Description	
Semi closed loop control	Feature	Position is controlled according to the servo motor-side data.
	Advantage	Since this control is insusceptible to machine influence (such as machine resonance), the gains of the servo amplifier can be raised and the settling time shortened.
	Disadvantage	If the servo motor side is at a stop, the side may be vibrating or the load-side accuracy not obtained.
Dual feedback control	Feature	Position is controlled according to the servo motor-side data and load-side data.
	Advantage	Control is performed according to the servo motor-side data during operation, and according to the load side-data at a stop in sequence to raise the gains during operation and shorten the settling time. A stop is made with the load-side accuracy.
Fully closed loop control	Feature	Position is controlled according to the load-side data.
	Advantage	The load-side accuracy is obtained not only at a stop but also during operation.
	Disadvantage	Since this control is susceptible to machine resonance or other influences, the gains of the servo amplifier may not rise.

16. FULLY CLOSED LOOP SYSTEM

16.1.2 Selecting procedure of control mode

(1) Control mode configuration

In this servo, a semi closed loop system or fully closed loop system can be selected as a control system. In addition, on the fully closed loop system, the semi closed loop control, fully closed loop control and dual feedback control can be selected by the [Pr. PE08] settings.

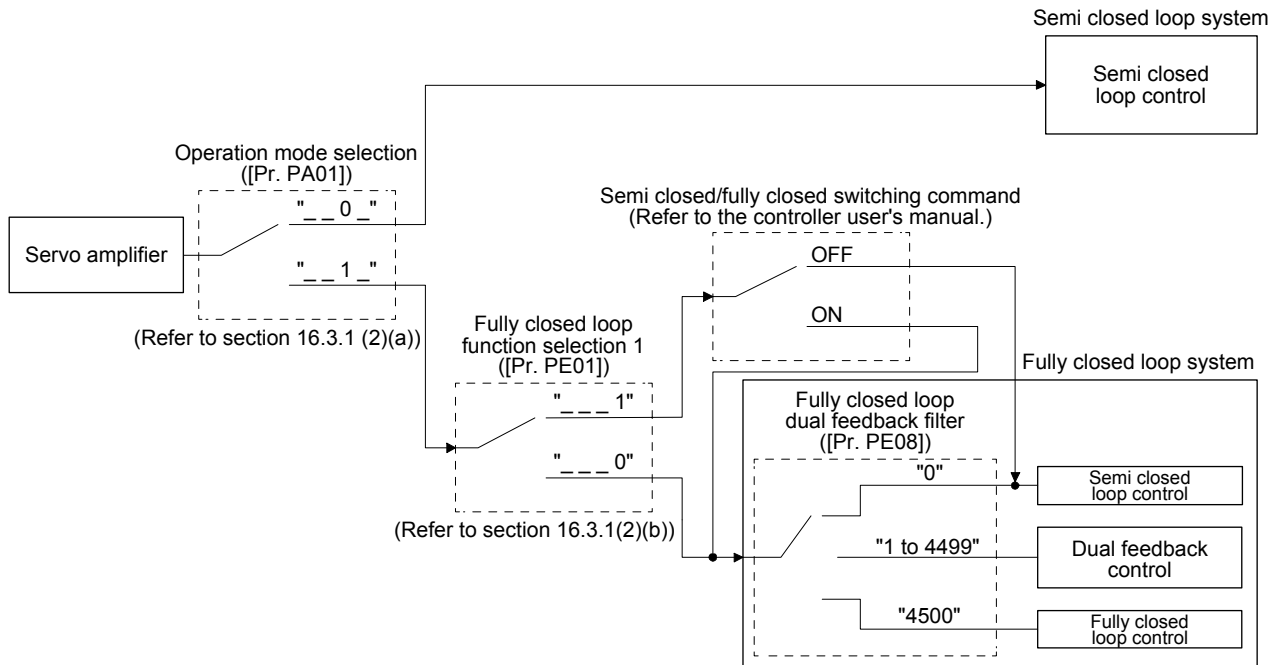

(2) Dual feedback filter equivalent block diagram

A dual feedback filter equivalent block diagram on the dual feedback control is shown below.

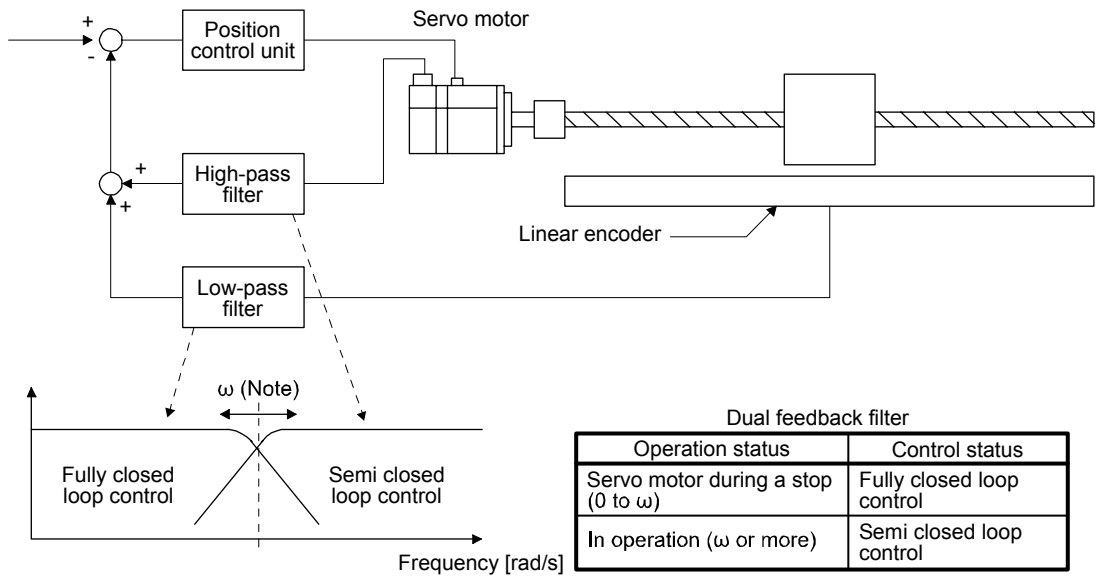

Note. " ω " (a dual feedback filter band) is set by [Pr. PE08].

16. FULLY CLOSED LOOP SYSTEM

16.1.3 System configuration

(1) For a linear encoder

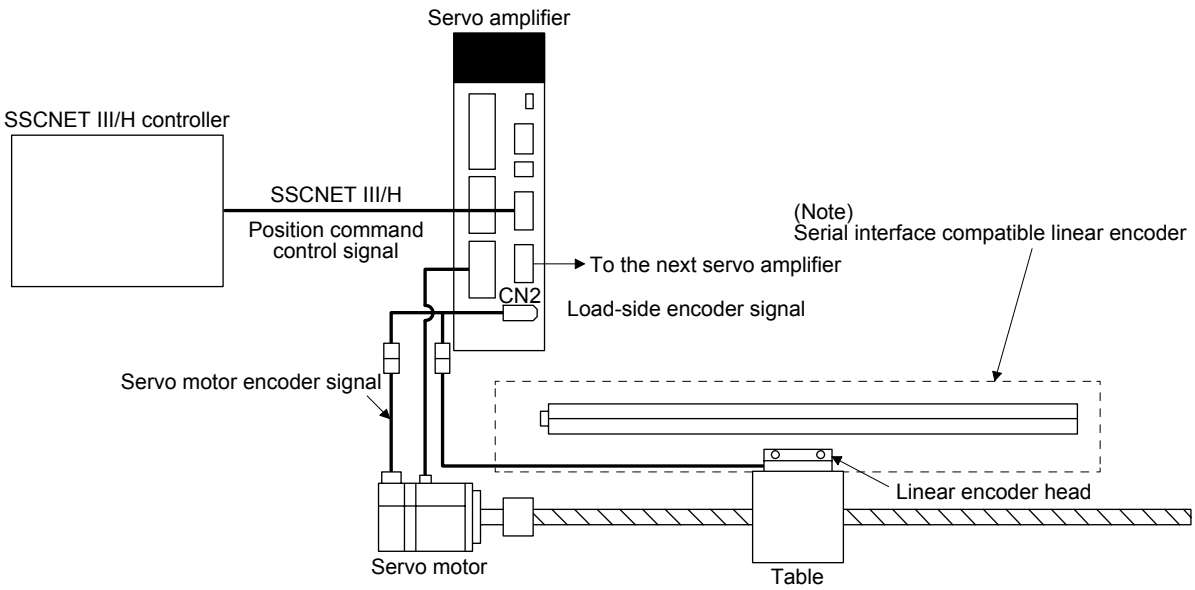

Note. Applicable for the absolute position detection system when an absolute position linear encoder is used.
In that case, a battery is not required.

(2) For a rotary encoder

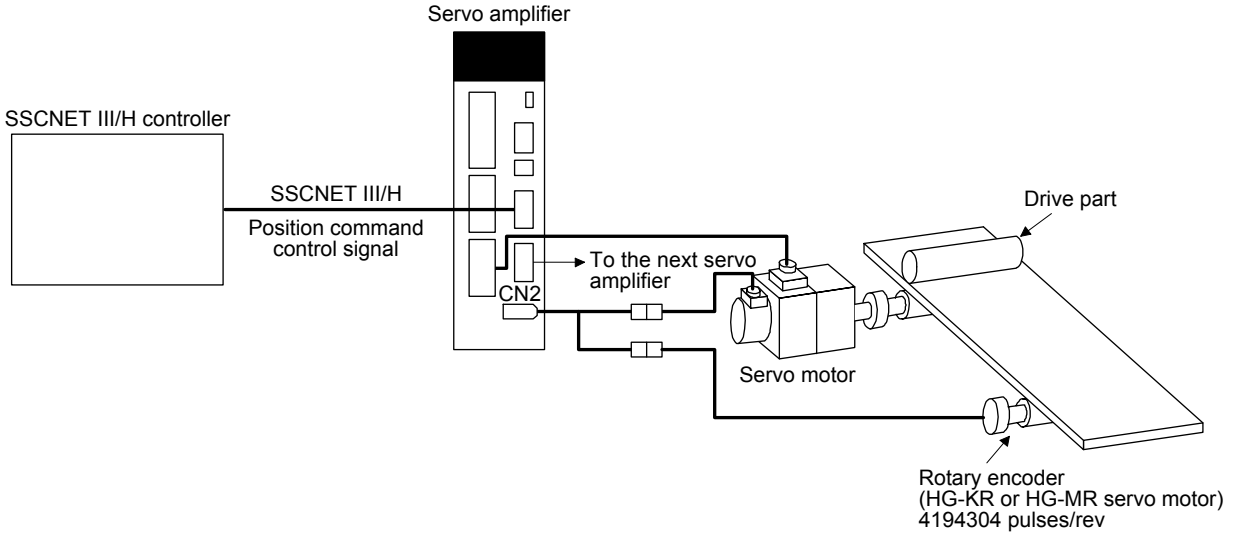

16. FULLY CLOSED LOOP SYSTEM

16.2 Load-side encoder

POINT
<ul style="list-style-type: none"> ● Always use the load-side encoder cable introduced in this section. Using other products may cause a malfunction. ● For details of the load-side encoder specifications, performance and assurance, contact each encoder manufacturer.

16.2.1 Linear encoder

Refer to "Linear Encoder Instruction Manual" for usable linear encoders.

16.2.2 Rotary encoder

When a rotary encoder is used for the load-side encoder, use HG-KR or HG-MR servo motor as an encoder. Use a two-wire type encoder cable. Do not use MR-EKCBL30M-L, MR-EKCBL30M-H, MR-EKCBL40M-H, or MR-EKCBL50M-H as they are four-wire type.

16.2.3 Configuration diagram of encoder cable

Configuration diagram for servo amplifier and load-side encoder is shown below. Cables used vary, depending on the load-side encoder.

(1) Linear encoder

Refer to Linear Encoder Instruction Manual for encoder cables for linear encoder.

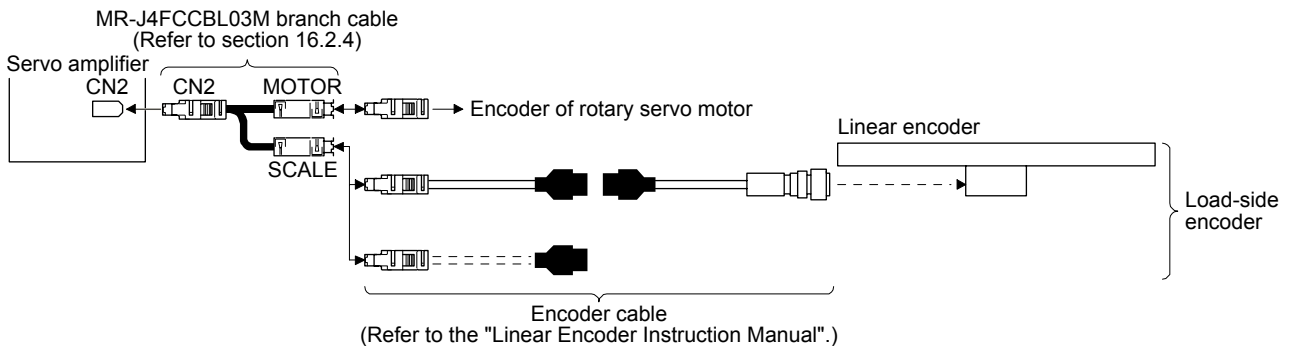

(2) Rotary encoder

Refer to "Servo Motor Instruction Manual (Vol. 3)" for encoder cables for rotary encoders.

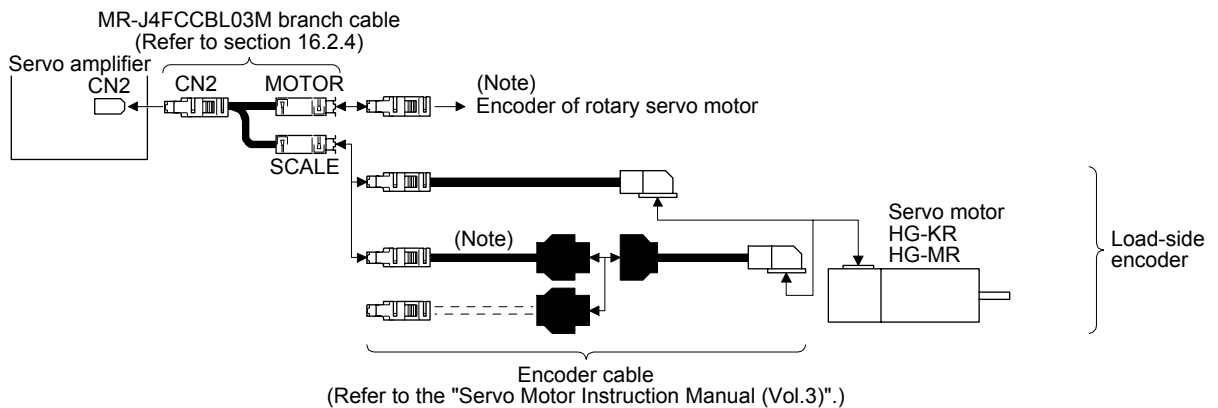

Note. Use a two-wire type encoder cable. A four-wire type linear encoder cable cannot be used.

16. FULLY CLOSED LOOP SYSTEM

16.2.4 MR-J4FCCBL03M branch cable

Use MR-J4FCCBL03M branch cable to connect the rotary encoder and the load-side encoder to CN2 connector.

When fabricating the branch cable using MR-J3THMCN2 connector set, refer to "Linear Encoder Instruction Manual".

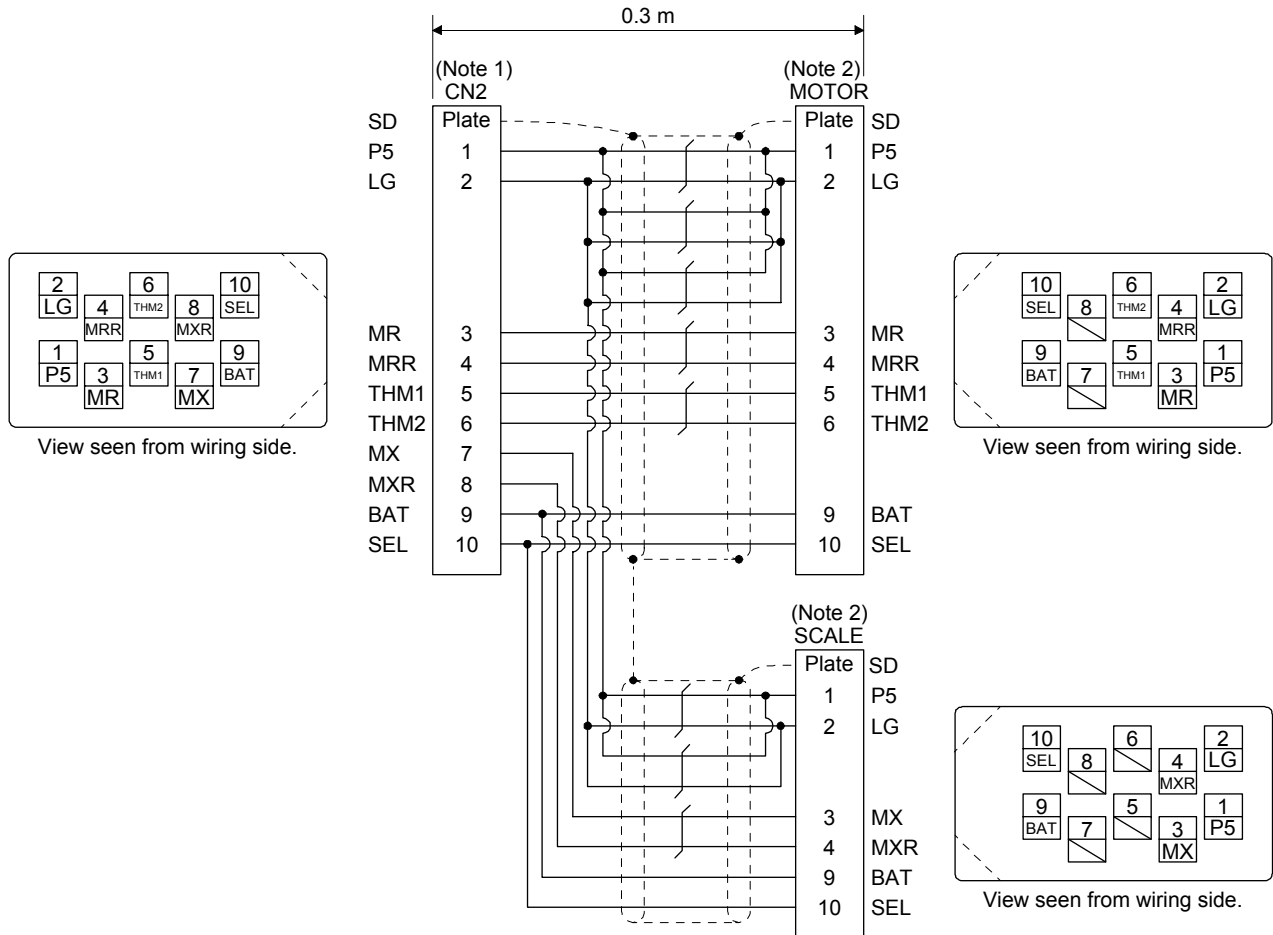

- Note 1. Receptacle: 36210-0100PL, shell kit: 36310-3200-008 (3M)
 Note 2. Plug: 36110-3000FD, shell kit: 36310-F200-008 (3M)

16. FULLY CLOSED LOOP SYSTEM

16.3 Operation and functions

16.3.1 Startup

(1) Startup procedure

Start up the fully closed loop system in the following procedure.

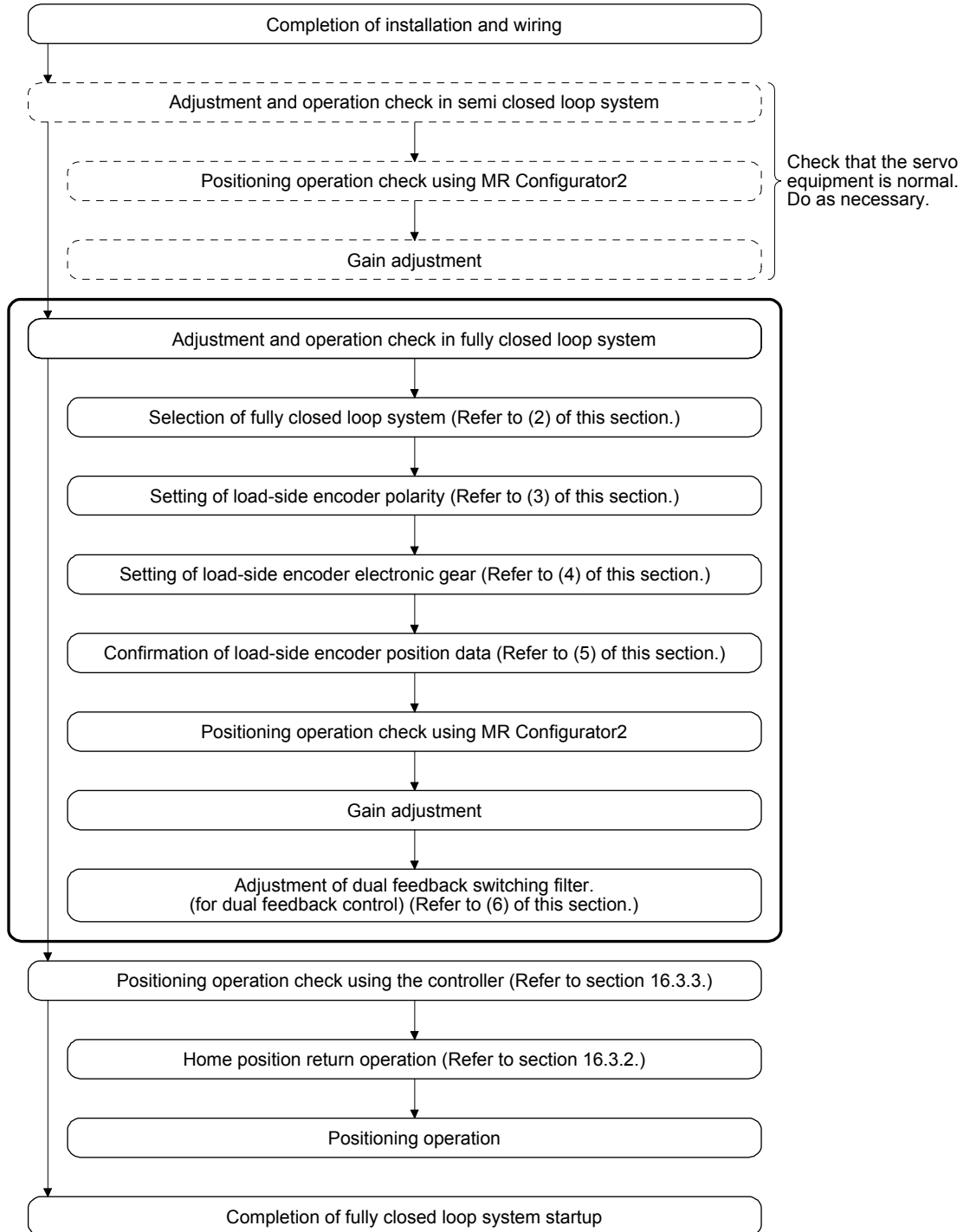

16. FULLY CLOSED LOOP SYSTEM

(2) Selection of fully closed loop system

By setting [Pr. PA01], [Pr. PE01] and the control command of controller, the control method can be selected as shown in the following table.

[Pr. PA01]	[Pr. PE01]	Semi closed loop control/ fully closed loop control switching signal	Command unit	Control System	Absolute position detection system
"__0_" Semi closed loop system (standard control mode)	/	/	Servo motor encoder unit	Semi closed loop control	○
"__1_" Fully closed loop system (fully closed loop control mode)			Load-side encoder unit	Dual feedback control (fully closed loop control)	○ (Note)
	"___0"	Off		Semi closed loop control	×
	"___1"	On		Dual feedback control (fully closed loop control)	×

Note. Applicable when the load-side encoder is set as the absolute position encoder.

(a) Operation mode selection

Select a operation mode.

[Pr. PA01]			
0	0		0

Operation mode selection

Set value	Operation mode	Control unit
0	Semi closed loop system (Standard control mode)	Servo motor-side resolution unit
1	Fully closed loop system (Fully closed loop control mode)	Load-side encoder resolution unit

(b) Semi closed loop control/fully closed loop control selection

Select the semi closed loop control/fully closed loop control.

[Pr. PE01]			
0	0	0	

Fully closed loop control selection

0: Always enabled

1: Switching using the control command of controller
(switching between semi closed/fully closed)

Selection using the control command of controller	Control method
OFF	Semi closed loop control
ON	Fully closed loop control

When the operation mode selection in [Pr. PA01] is set to "__1_"
(fully closed loop system), this setting is enabled.

16. FULLY CLOSED LOOP SYSTEM

(3) Setting of load-side encoder polarity

! CAUTION

- Do not set an incorrect direction to "Encoder pulse count polarity selection" in [Pr. PC27]. An abnormal operation and a machine collision may occur if an incorrect direction is set, which cause a fault and parts damaged.

POINT

- "Encoder pulse count polarity selection" in [Pr. PC27] is not related to [Pr. PA14 Rotation direction selection]. Make sure to set the parameter according to the relationships between servo motor and linear encoder/rotary encoder.
- Do not set an incorrect direction to "Encoder pulse count polarity selection" in [Pr. PC27]. Doing so may cause [AL. 42 Fully closed loop control error] during the positioning operation.

(a) Parameter setting method

Set the load-side encoder polarity to be connected to CN2L connector in order to match the CCW direction of servo motor and the increasing direction of load-side encoder feedback.

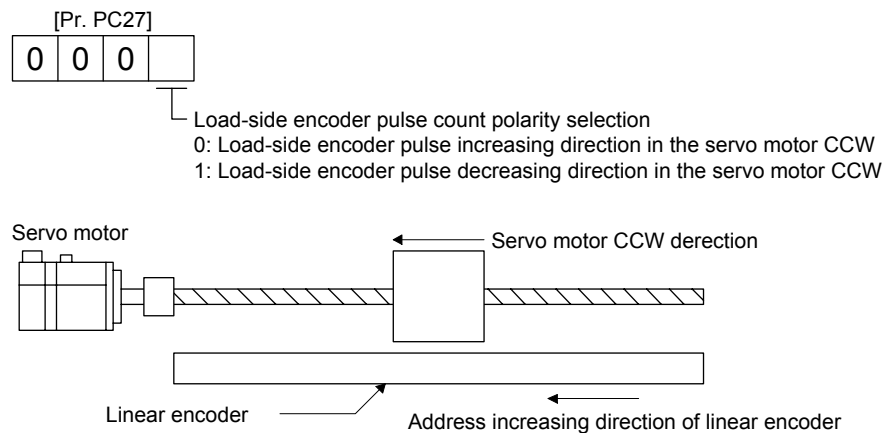

(b) How to confirm the load-side encoder feedback direction

For the way of confirming the load-side encoder feedback direction, refer to (5) in this section.

16. FULLY CLOSED LOOP SYSTEM

(4) Setting of feedback pulse electronic gear

POINT
<p>● If an incorrect value is set in the feedback pulse electronic gear ([Pr. PE04], [Pr. PE05], [Pr. PE34], and [Pr. PE35]), [AL. 37 Parameter error] and an abnormal operation may occur. Also, it may cause [AL. 42.1 Fully closed loop control error by potision deviation] during the positioning operation.</p>

The numerator ([Pr. PE04] and [Pr. PE34]) and denominator ([Pr. PE05] and [Pr. PE35]) of the electronic gear are set to the servo motor-side encoder pulse. Set the electronic gear so that the number of servo motor encoder pulses per servo motor revolution is converted to the number of load-side encoder pulses. The relational expression is shown below.

$$\frac{[\text{Pr. PE04}] \times [\text{Pr. PE34}]}{[\text{Pr. PE05}] \times [\text{Pr. PE35}]} = \frac{\text{Number of motor encoder pulses per servo motor revolution}}{\text{Number of load side encoder pulses per servo motor revolution}}$$

Select the load-side encoder so that the number of load-side encoder pulses per servo motor revolution is within the following range.

$$4096(2^{12}) \leq \text{Number of load-side encoder pulses per servo motor revolution} \leq 67108864 (2^{26})$$

(a) When the servo motor is directly coupled with a ball screw and the linear encoder resolution is 0.05 μm

Conditions

Servo motor resolution: 4194304 pulses/rev

Servo motor reduction ratio: 1/11

Ball screw lead: 20 mm

Linear encoder resolution: 0.05 μm

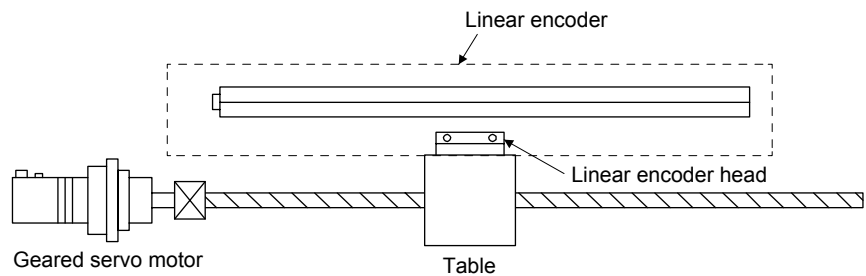

Calculate the number of linear encoder pulses per ball screw revolution.

Number of linear encoder pulses per ball screw revolution
 = Ball screw lead/linear encoder resolution
 = 20 mm/0.05 μm = 400000 pulses

$$\frac{[\text{Pr. PE04}] \times [\text{Pr. PE34}]}{[\text{Pr. PE05}] \times [\text{Pr. PE35}]} = \frac{400000}{4194304} \times \frac{1}{11} = \frac{3125}{32768} \times \frac{1}{11}$$

16. FULLY CLOSED LOOP SYSTEM

(b) Setting example when using the rotary encoder for the load-side encoder of roll feeder

Conditions

Servo motor resolution: 4194304 pulses/rev

Pulley diameter on the servo motor side: 30 mm

Pulley diameter on the rotary encoder side: 20 mm

Rotary encoder resolution: 4194304 pulse/rev

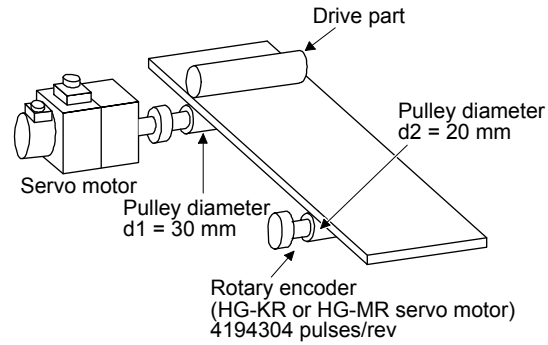

When the pulley diameters or reduction ratios differ, consider that in calculation.

$$\frac{[\text{Pr. PE04}] \times [\text{Pr. PE34}]}{[\text{Pr. PE05}] \times [\text{Pr. PE35}]} = \frac{4194304 \times 30}{4194304 \times 20} = \frac{1}{1} \times \frac{3}{2}$$

16. FULLY CLOSED LOOP SYSTEM

(5) Confirmation of load-side encoder position data

Check the load-side encoder mounting and parameter settings for any problems.

POINT
<ul style="list-style-type: none"> ● Depending on the check items, MR Configurator2 may be used. Refer to section 16.3.6 for the data displayed on the MR Configurator2.

When checking the following items, the fully closed loop control mode must be set. For the setting of control mode, refer to (2) in this section.

No.	Check item	Confirmation method and description
1	Read of load-side encoder position data	<p>With the load-side encoder in a normal state (mounting, connection, etc.), the load-side cumulative feedback pulses value is counted normally when the load-side encoder is moved.</p> <p>When it is not counted normally, the following factors can be considered.</p> <ol style="list-style-type: none"> 1. An alarm occurred. 2. The installation of the load-side encoder was not correct. 3. The encoder cable was not wired correctly.
2	Read of load-side encoder scale home position (reference mark, Z-phase)	<p>With the home position (reference mark, or Z-phase) of the load-side encoder in a normal condition (mounting, connection, etc.), the value of load-side encoder information 1 is cleared to 0 when the home position (reference mark, or Z-phase) is passed through by moving the load-side encoder.</p> <p>When it is not cleared, the following factors can be considered.</p> <ol style="list-style-type: none"> 1. The installation of the load-side encoder was not correct. 2. The encoder cable was not wired correctly.
3	Confirmation of load-side encoder feedback direction (Setting of load-side encoder polarity)	<p>Confirm that the directions of the cumulative feedback pulses of servo motor encoder (after gear) and the load-side cumulative feedback pulses are matched by moving the device (load-side encoder) manually in the servo-off status. If mismatched, reverse the polarity.</p>
4	Setting of load-side encoder electronic gear	<p>When the servo motor and load-side encoder operate synchronously, the servo motor-side cumulative feedback pulses (after gear) and load-side cumulative feedback pulses are matched and increased.</p> <p>If mismatched, review the setting of fully closed loop control feedback electronic gear ([Pr. PE04], [Pr. PE05], [Pr. PE34], and [Pr. PE35]) with the following method.</p> <ol style="list-style-type: none"> 1) Check the servo motor-side cumulative feedback pulses (before gear). 2) Check the load-side cumulative feedback pulses. 3) Check that the ratio of above 1) and 2) has been that of the feedback electronic gear.

16. FULLY CLOSED LOOP SYSTEM

(6) Setting of fully closed loop dual feedback filter

With the initial value (setting = 10) set in [Pr. PE08 Fully closed loop dual feedback filter the dual feedback filter], make gain adjustment by auto tuning, etc. as in semi closed loop control. While observing the servo operation waveform with the graph function, etc. of MR Configurator2, adjust the dual feedback filter.

The dual feedback filter operates as described below depending on the setting.

[Pr. PE08] setting	Control mode	Vibration	Settling time
0	Semi closed loop		
1 to 4499	Dual feedback	Not frequently occurs to Frequently occurs	Long time to Short time
4500	Fully closed loop		

Increasing the dual feedback filter setting shortens the settling time, but increases servo motor vibration since the motor is more likely to be influenced by the load-side encoder vibration. The maximum setting of the dual feedback filter should be less than half of the PG2 setting.

Reduction of settling time: Increase the dual feedback filter setting.

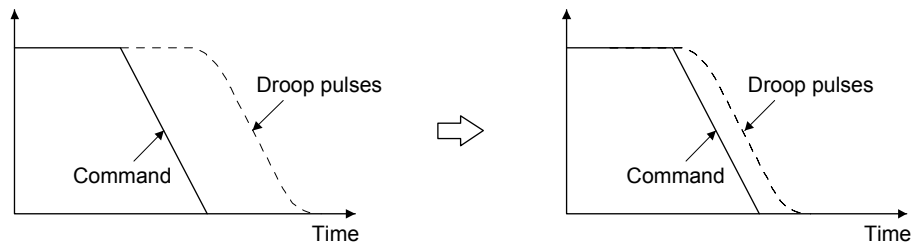

Suppression of vibration: Decrease the dual feedback filter setting.

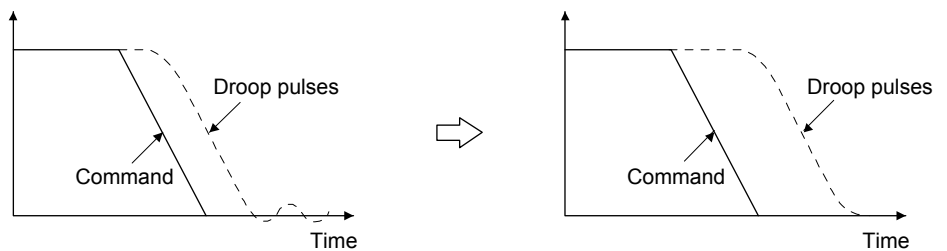

16. FULLY CLOSED LOOP SYSTEM

16.3.2 Home position return

(1) General instruction

Home position return is all performed according to the load-side encoder feedback data, independently of the load-side encoder type. It is irrelevant to the Z-phase position of the servo motor encoder. In the case of a home position return using a dog signal, the scale home position (reference mark) must be passed through when an incremental type linear encoder is used, or the Z-phase be passed through when a rotary encoder is used, during a period from a home position return start until the dog signal turns off.

(2) Load-side encoder types and home position return methods

(a) About proximity dog type home position return using absolute type linear encoder

When an absolute type linear encoder is used, the home position reference position is the position per servo motor revolution to the linear encoder home position (absolute position data = 0). In the case of a proximity dog type home position return, the nearest position after proximity dog off is the home position.

The linear encoder home position may be set in any position.

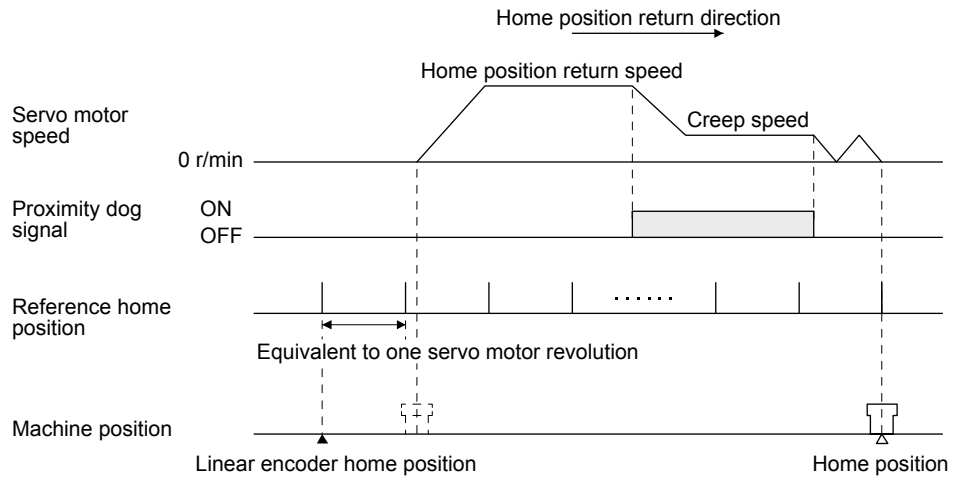

16. FULLY CLOSED LOOP SYSTEM

(b) About proximity dog type home position return using incremental linear encoder

1) When the linear encoder home position (reference mark) exists in the home position return direction

When an incremental linear encoder is used, the home position is the position per servo motor revolution to the linear encoder home position (reference mark) passed through first after a home position return start.

In the case of a proximity dog type home position return, the nearest position after proximity dog off is the home position.

Set one linear encoder home position in the full stroke, and set it in the position that can always be passed through after a home position return start.

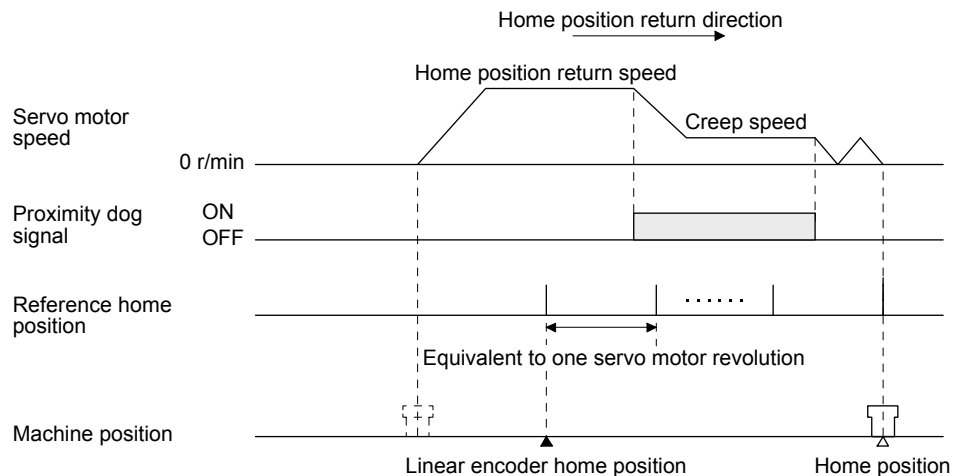

2) When the linear encoder home position does not exist in the home position return direction

If the home position return is performed from the position where the linear encoder home position (reference mark) does not exist, a home position return error occurs on the controller side. The error contents differ according to the controller type. When starting a home position return at the position where the linear encoder home position (reference mark) does not exist in the home position return direction, move the axis up to the stroke end on the side opposite to the home position return direction by JOG operation, etc. of the controller once, then make a home position return.

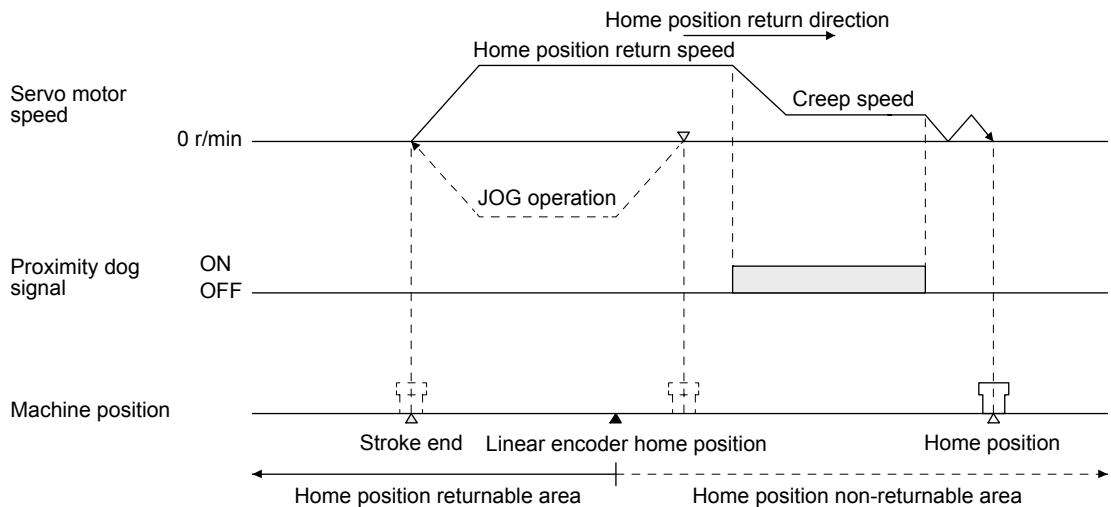

16. FULLY CLOSED LOOP SYSTEM

POINT
<ul style="list-style-type: none"> ● To execute a home position return securely, start a home position return after moving the axis to the opposite stroke end by jog operation, etc. of the controller. ● A home position return cannot be made if the incremental linear encoder does not have a linear encoder home position (reference mark). Always provide a linear encoder home position (reference mark). (one place in the fully stroke)

(c) About dog type home position return when using the rotary encoder of a serial communication servo motor

The home position for when using the rotary encoder of a serial communication servo motor for the load-side encoder is at the load-side Z-phase position.

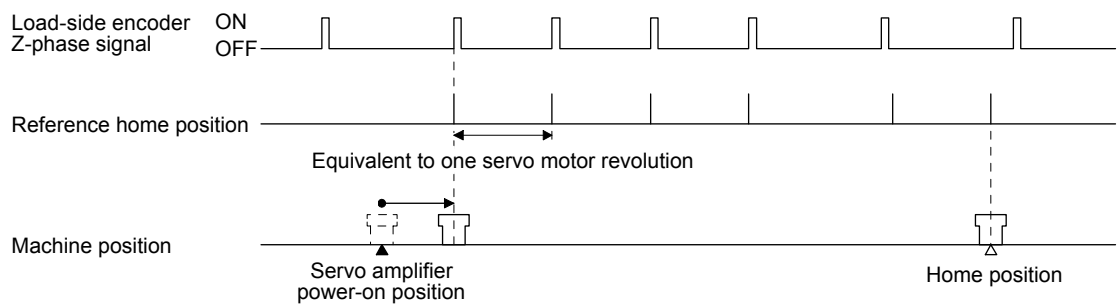

(b) About data setting type (Common to all load-side encoders)

In the data setting type home position return method, pass through a scale home position (reference mark) and the Z-phase signal of the rotary encoder, and then make a home position return.

When the machine has no distance of one servo motor encoder revolution until the Z-phase of the rotary encoder is passed through, a home position return can be made by changing the home position setting condition selection in [Pr. PC17] if the home position is not yet passed through.

16. FULLY CLOSED LOOP SYSTEM

16.3.3 Operation from controller

The fully closed loop control compatible servo amplifier can be used with any of the following controllers.

Category	Model	Remarks
Motion controller	Q17nDSCPU	Speed control (II) instructions (VVF and VVR) cannot be used.
Simple motion module	QD77MS_	

An absolute type linear encoder is necessary to configure an absolute position detection system under fully closed loop control using a linear encoder. In this case, the encoder battery need not be installed to the servo amplifier. When an rotary encoder is used, an absolute position detection system can be configured by installing the encoder battery to the servo amplifier. In this case, the battery life will be shorter because the power consumption is increased as the power is supplied to the two encoders of motor side and load side.

(1) Operation from controller

Positioning operation from the controller is basically performed like the semi closed loop control.

(2) Servo system controller setting

When using fully closed loop system, make the following setting.

[Pr. PA01], [Pr. PC17], [Pr. PE01], [Pr. PE03] to [Pr. PE05], [Pr. PE34] and [Pr. PE35] are written to the servo amplifier and then are enabled using any of the methods indicated by ○ in Parameter enabled conditions. [Pr. PE06] to [Pr. PE08] are enabled at setting regardless of the valid conditions.

Setting item		Parameter enabled conditions		Settings	
		Controller reset	Power supply Off→on	Motion controller Q17nDSCPU	Simple motion module QD77MS_
Command resolution				Load-side encoder resolution unit	
Servo parameter	MR-J4-B fully closed loop servo amplifier setting			MR-J4-B fully closed loop control	
	Motor setting			Automatic setting	
	Home position setting condition selection ([Pr. PC17])	○	○	Set the items as required.	
	Fully closed loop selection ([Pr. PA01] and [Pr. PE01])	×	○		
	Fully closed loop selection 2 ([Pr. PE03])	○	○		
	Fully closed loop control error detection speed deviation error detection level ([Pr. PE06])	Enabled at setting regardless of the enabled conditions			
	Fully closed loop control error detection position deviation error detection level ([Pr. PE07])				
	Fully closed loop electronic gear numerator ([Pr. PE04] and [Pr. PE34])	×	○		
	Fully closed loop electronic gear denominator ([Pr. PE05] and [Pr. PE35])	×	○		
Fully closed loop dual feedback filter ([Pr. PE08])	Enabled at setting regardless of the enabled conditions				
Positioning control parameter	Unit setting	mm/inch/degree/pulse			
	Number of pulses per revolution (AP) Travel distance per revolution (AL)	For the setting methods, refer to (2) (a), (b) in this section.			

16. FULLY CLOSED LOOP SYSTEM

(a) When using a linear encoder (unit setting: mm)

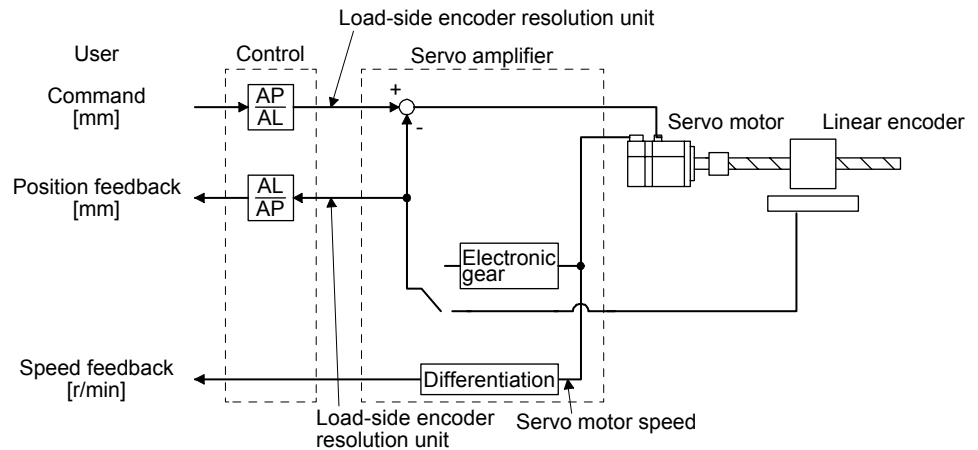

Calculate the number of pulses (AP) and travel distance (AL) of the linear encoder per ball screw revolution in the following conditions.

Ball screw lead: 20 mm

Linear encoder resolution: 0.05 μm

Number of linear encoder pulses (AP) per ball screw revolution

$$= \text{Ball screw lead/linear encoder resolution} = 20 \text{ mm}/0.05 \mu\text{m} = 400000 \text{ pulses}$$

$$\frac{\text{Number of pulses per revolution [pulse] (AP)}}{\text{Travel distance per revolution } [\mu\text{m}] \text{ (AL)}} = \frac{400000 \text{ pulses}}{20 \text{ mm}} = \frac{400000}{20000}$$

(b) When using a rotary encoder (unit setting: deg)

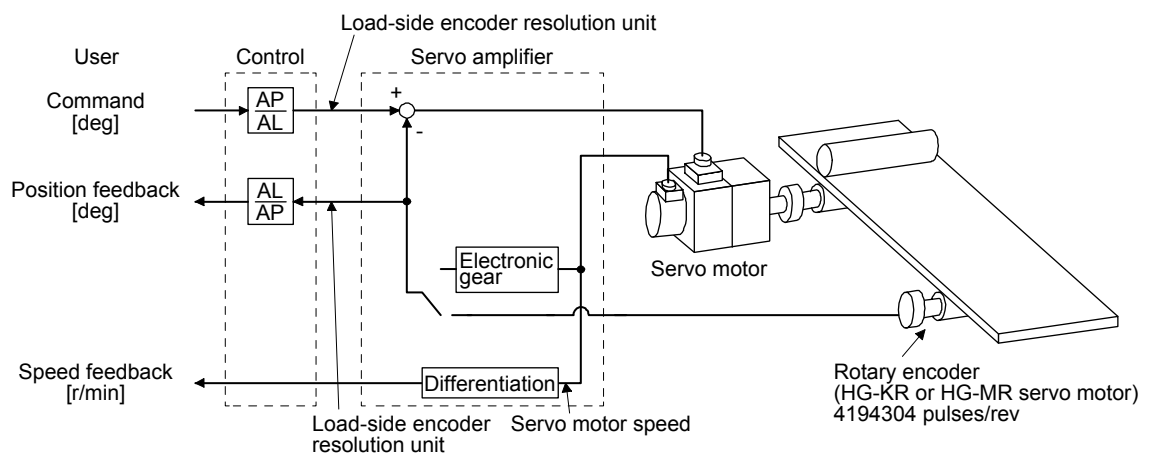

Calculate the number of pulses (AP) and travel distance (AL) of the rotary encoder per servo motor revolution in the following conditions.

Resolution of rotary encoder = Load-side resolution: 4194304 pulses/rev

$$\frac{\text{Number of pulses per revolution [pulse] (AP)}}{\text{Travel distance per revolution [deg] (AL)}} = \frac{4194304 \text{ pulses}}{360 \text{ deg}} = \frac{524288}{45}$$

16. FULLY CLOSED LOOP SYSTEM

16.3.4 Fully closed loop control error detection functions

If fully closed loop control becomes unstable for some reason, the speed at servo motor side may increase abnormally. The fully closed loop control error detection function is a protective function designed to pre-detect it and stop operation.

The fully closed loop control error detection function has two different detection methods, speed deviation and position deviation, and errors are detected only when the corresponding functions are enabled by setting [Pr. PE03 Fully closed loop function selection 2].

The detection level setting can be changed using [Pr. PE06] and [Pr. PE07].

(1) Parameter

The fully closed loop control error detection function is selected.

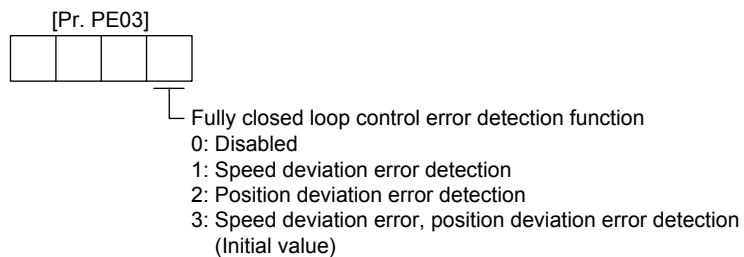

(2) Fully closed loop control error detection functions

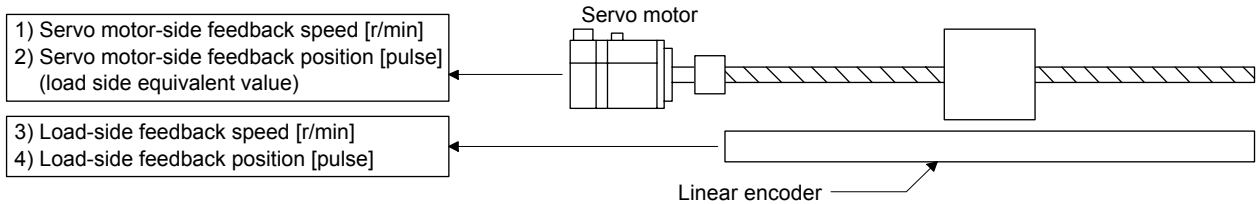

(a) Speed deviation error detection

Set [Pr. PE03] to " __ _ 1" to enable the speed deviation error detection.

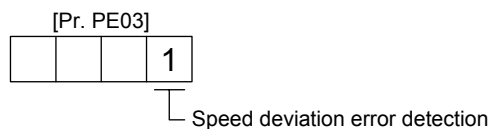

The function compares the servo motor-side feedback speed (1)) and load-side feedback speed (3)). If the deviation is not less than the set value (1 r/min to the permissible speed) of [Pr. PE06 Fully closed loop control speed deviation error detection level], the function generates [AL. 42.2 Servo control error by speed deviation] and stops. The initial value of [Pr. PE06] is 400 r/min. Change the set value as required.

16. FULLY CLOSED LOOP SYSTEM

(b) Position deviation error detection

Set [Pr. PE03] to "___2" to enable the position deviation error detection.

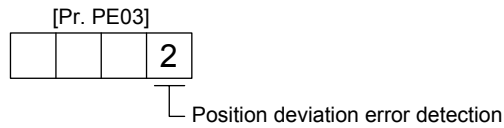

Comparing the servo motor-side feedback position (2)) and load-side feedback position (4)), if the deviation is not less than the set value (1 kpulses to 20000 kpulses) of [Pr. PE07 Fully closed loop control position deviation error detection level], the function generates [AL. 42 42.1 Servo control error by position deviation] and stops. The initial value of [Pr. PE07] is 100 kpulses. Change the set value as required.

(c) Detecting multiple deviation errors

When setting [Pr. PE03] as shown below, multiple deviation errors can be detected. For the error detection method, refer to (2) (a), (b) in this section.

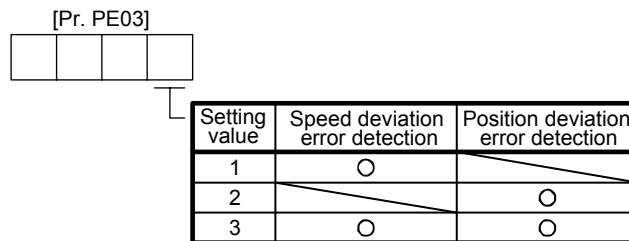

16.3.5 Auto tuning function

Refer to section 6.3 for the auto tuning function.

16.3.6 Machine analyzer function

Refer to Help of MR Configurator2 for the machine analyzer function of MR Configurator2.

16.3.7 Test operation mode

Test operation mode is enabled by MR Configurator2.

For details on the test operation mode, refer to section 4.5.

Function	Item	Usability	Remarks
Test operation mode	JOG operation	○	It drives in the load-side encoder resolution unit
	Positioning operation	○	The fully closed loop system is operated in the load-side encoder resolution unit. For details, refer to section 4.5.1 (1) (c).
	Program operation	○	
	Output signal (DO) forced output	○	Refer to section 4.5.1 (1) (b).
	Motor-less operation	/	

16. FULLY CLOSED LOOP SYSTEM

16.3.8 Absolute position detection system under fully closed loop system

An absolute type linear encoder is necessary to configure an absolute position detection system under fully closed loop control using a linear encoder. In this case, the encoder battery need not be installed to the servo amplifier. When an rotary encoder is used, an absolute position detection system can be configured by installing the encoder battery to the servo amplifier. In this case, the battery life will be shorter because the power consumption is increased as the power is supplied to the two encoders of motor side and load side. For the absolute position detection system with linear encoder, the restrictions mentioned in this section apply. Enable the absolute position detection system with [Pr. PA03 Absolute position detection system] and use this servo within the following restrictions.

(1) Using conditions

- (a) Use an absolute type linear encoder with the load-side encoder.
- (b) Select Always fully closed loop ([Pr. PA01] = __ 1 _ and [Pr. PE01] = ___ 0).

(2) Absolute position detection range using encoder

Encoder type	Absolute position detection enabled range
Linear encoder (Serial Interface)	Movable distance range of scale (within 32-bit absolute position data)

(3) Alarm detection

The absolute position-related alarm ([AL. 25]) and warnings (AL. 92] and [AL. 9F]) are not detected.

16. FULLY CLOSED LOOP SYSTEM

16.3.9 About MR Configurator2

Using MR Configurator2 can confirm if the parameter setting is normal or if the servo motor and the load-side encoder operate properly.

This section explains the fully closed diagnosis screen.

Click "Monitor start" to constantly read the monitor display items from the servo amplifier.

Then, click "Monitor stop" to stop reading. Click "Parameter read" to read the parameter items from the servo amplifier, and then click "Parameter write" to write them.

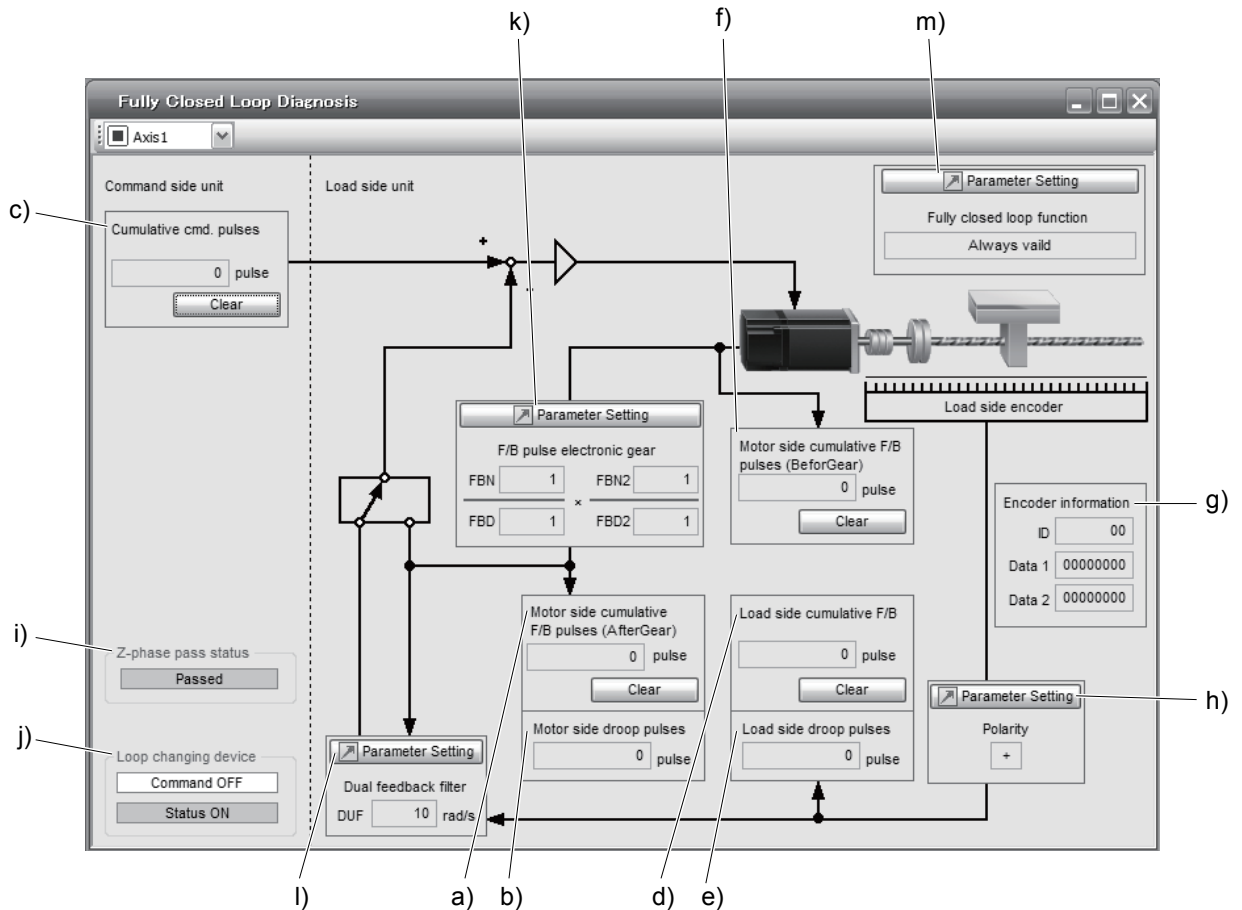

Symbol	Name	Explanation	Unit
a)	Motor side cumu. feedback pulses (after gear)	Feedback pulses from the servo motor encoder are counted and displayed. (load-side encoder unit) When the set value exceeds 999999999, it starts with 0. Click "Clear" to reset the value to 0. The "-" symbol is indicated for reverse.	pulse
b)	Motor side droop pulses	Droop pulses of the deviation counter between a servo motor-side position and a command are displayed. The "-" symbol is indicated for reverse.	pulse
C	Cumu. Com. pulses	Position command input pulses are counted and displayed. Click "Clear" to reset the value to 0. The "-" symbol is indicated for reverse command.	pulse
d)	Load side cumu. feedback pulses	Feedback pulses from the load-side encoder are counted and displayed. When the set value exceeds 999999999, it starts with 0. Click "Clear" to reset the value to 0. The "-" symbol is indicated for reverse.	pulse
E	Load side droop pulses	Droop pulses of the deviation counter between a load-side position and a command are displayed. The "-" symbol is indicated for reverse.	pulse

16. FULLY CLOSED LOOP SYSTEM

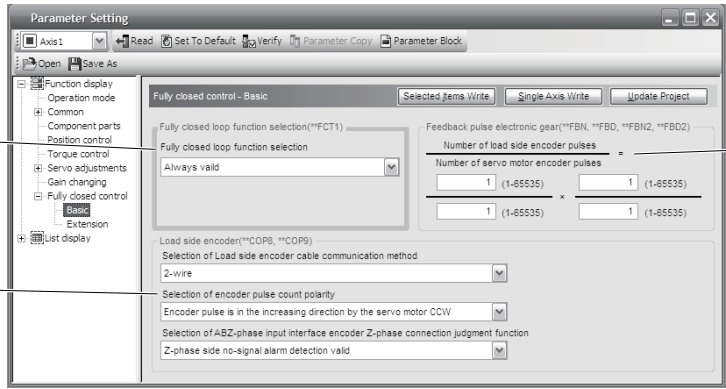
Symbol	Name	Explanation	Unit
f)	Motor side cumu. feedback pulses (before gear)	Feedback pulses from the servo motor encoder are counted and displayed. (Servo motor encoder unit) When the set value exceeds 999999999, it starts with 0. Click "Clear" to reset the value to 0. The "-" symbol is indicated for reverse.	pulse
g)	Encoder information	The load-side encoder information is displayed. The display contents differ depending on the load-side encoder type. <ul style="list-style-type: none"> • ID: The ID No. of the load-side encoder is displayed. • Data 1: For the incremental type linear encoder, the counter from powering on is displayed. For the absolute position type linear encoder, the absolute position data is displayed. • Data 2: For the incremental type linear encoder, the distance (number of pulses) from the reference mark (Z-phase) is displayed. For the absolute position type linear encoder, "0000000" is displayed. 	
h)	Polarity	For address increasing direction in the servo motor CCW, it is indicated as "+" and for address decreasing direction in the servo motor CCW, as "-".	
i)	Z phase pass status	If the fully closed loop system is "Disabled", the Z-phase pass status of the servo motor encoder is displayed. If the fully closed loop system is "Enabled" or "Semi closed loop control/fully closed loop control switching", the Z-phase pass status of the load-side encoder is displayed.	
j)	Fully closed loop changing device	Only if the fully closed loop system is "Semi closed loop control/fully closed loop control switching", the device is displayed. The state of the semi closed loop control/fully closed loop control switching bit and the inside state during selection are displayed.	
k)	Parameter (Feedback pulse electronic gear)	The feedback pulse electronic gears ([Pr. PE04], [Pr. PE05], [Pr. PE34], and [Pr. PE35]) are displayed/set for servo motor encoder pulses in this parameter. (Refer to section 16.3.1 (3).)	
l)	Parameter (Dual feedback filter)	The band of [Pr. PE08 Fully closed loop dual feedback filter] is displayed/set in this parameter.	
m)	Parameter (fully closed loop selection)	<p>The parameter for the fully closed loop control is displayed or set. Click "Parameter setting" button to display the "Fully closed loop control - Basic" window.</p>  <p>1) Fully closed loop selection ([Pr. PE01]) "Always valid" or "Switching with the control command of controller" is selected here.</p> <p>2) Feedback pulse electronic gear ([Pr. PE04], [Pr. PE05], [Pr. PE34], [Pr. PE35]) Setting of feedback pulse electronic gear</p> <p>3) Selection of encoder pulse count polarity ([Pr. PC27]) Polarity of the load-side encoder information is selected.</p>	

APPENDIX

App. 1 Auxiliary equipment manufacturer (for reference)

Names given in the table are as of February 2013.

Manufacturer	Reference
JST	J.S.T. Mfg. Co., Ltd.
Junkosha	Purchase from Toa Electric Industry Co. Ltd., Nagoya Branch
3M	3M
Soshin Electric	Soshin Electric Co., Ltd.
TE Connectivity	TE Connectivity
Molex	Molex

App. 2 Handling of AC servo amplifier batteries for the United Nations Recommendations on the Transport of Dangerous Goods

United Nations Recommendations on the Transport of Dangerous Goods Rev. 15 (hereinafter Recommendations of the United Nations) has been issued. To reflect this, transport regulations for lithium metal batteries are partially revised in the Technical Instruction (ICAO-TI) by the International Civil Aviation Organization (ICAO) and the International Maritime Dangerous Goods Code (IMDG Code) by the International Maritime Organization (IMO).

To comply the instruction and code, we have modified the indication on the package for general-purpose AC servo batteries.

The above change will not affect the function and performance of the product.

- (1) Target model
 - (a) Battery (cell)

Model	Option model
ER6	MR-J3BAT
ER17330	MR-BAT, A6BAT

- (b) Battery unit (assembled)

Model	Option model
ER17330	MR-J2M-BT
CR17335A	MR-BAT6V1
	MR-BAT6V1SET

- (2) Purpose
 - Safer transportation of lithium metal batteries.

- (3) Change in regulations
 - The following points are changed for lithium metal batteries transportation by sea or air due to Recommendations of the United Nations Rev. 15 and ICAO-TI 2009-2010 edition. For lithium metal batteries, cells are classified as UN3090, and batteries contained in or packed with equipment are classified as UN3091.

- (a) A package containing 24 cells or 12 batteries or less that are not contained in equipment are no longer exempt from the following: attachment of a handling label, submission of the Shipper's Declaration for Dangerous Goods, and a 1.2 m drop test.
- (b) A battery handling label (size: 120 mm × 110 mm) is required. Emergency telephone number must be filled out in the additional handling information of the Shipper's Declaration for Dangerous Goods.

APPENDIX

(c) New handling label design containing battery illustration must be used. (only air transportation)



Figure. Example of Mitsubishi Label with Battery Illustration

(4) Action taken by Mitsubishi

The following caution will be added to the packages of the target batteries.

"Containing lithium metal battery. Regulations apply for transportation."

(5) Transportation precaution for customers

For sea or air transportation, attaching the handling label (figure) and the Shipper's Declaration for Dangerous Goods are required to the package of a Mitsubishi cell or battery. In addition, attaching them to the outer package containing several packages of Mitsubishi cells or batteries are also required. Please attach the documentations in the specified design to the packages and the outer packages.

APPENDIX

App. 3 Symbol for the new EU Battery Directive

Symbol for the new EU Battery Directive (2006/66/EC) that is plastered to general-purpose AC servo battery is explained here.



Note. This symbol mark is for EU countries only.

This symbol mark is according to the directive 2006/66/EC Article 20 Information for end-users and Annex II. Your MITSUBISHI ELECTRIC product is designed and manufactured with high quality materials and components which can be recycled and/or reused.

This symbol means that batteries and accumulators, at their end-of-life, should be disposed of separately from your household waste.

If a chemical symbol is printed beneath the symbol shown above, this chemical symbol means that the battery or accumulator contains a heavy metal at a certain concentration.

This will be indicated as follows.

Hg: mercury (0.0005%), Cd: cadmium (0.002%), Pb: lead (0.004%)

In the European Union there are separate collection systems for used batteries and accumulators. Please, dispose of batteries and accumulators correctly at your local community waste collection/recycling centre. Please, help us to conserve the environment we live in!

App. 4 Compliance with overseas standards

App. 4.1 Terms related to safety (IEC/EN 61800-5-2 Stop function)

STO function (Refer to IEC/EN 61800-5-2: 2007 4.2.2.2 STO.)

MR-J4 servo amplifiers have the STO function. The STO function shuts down energy to servo motors, thus removing torque. This function electronically cuts off power supply in the servo amplifier.

App. 4.2 About safety

This chapter explains safety of users and machine operators. Please read the chapter carefully before mounting the equipment.

APPENDIX

App. 4.2.1 Professional engineer

Only professional engineers should mount MR-J4 servo amplifiers. Here, professional engineers should meet the all conditions below.

- (1) A person who took a proper engineering training
Please note if you can take proper engineering training at your local Mitsubishi Electric office. Contact your local sales office for schedules and locations.
- (2) A person who can access to operating manuals for the protective devices (e.g. light curtain) connected to the safety control system. A person who have read and familiarized himself/herself with the manuals.

App. 4.2.2 Applications of the devices

MR-J4 servo amplifiers comply with the following safety standards.
ISO/EN ISO 13849-1 Category 3 PL d, IEC/EN 62061 SIL CL 2, IEC/EN 61800-5-2 SIL 2 (STO), IEC/EN 61800-5-1, IEC/EN 61800-3, IEC/EN 60204-1
In addition, MR-J4 servo amplifiers can be used with the MR-J3-D05 safety logic unit or safety PLCs.

App. 4.2.3 Correct use

Always use the MR-J4 servo amplifiers within specifications (voltage, temperature, etc. Refer to each instruction manual for details.). Mitsubishi Electric Co. accepts no claims for liability if the equipment is used in any other way or if modifications are made to the device, even in the context of mounting and installation.

 **WARNING** ● It takes 15 minutes for capacitor discharging. Do not touch the unit and terminals immediately after power off.

- (1) Peripheral device and power wiring
 - (a) Local wiring and crimping tool
Use only copper wires rated at 60 °C/75 °C for wiring. The following table shows the wire sizes [AWG] and the crimp terminal symbols rated at 75 °C.

Servo amplifier	Wire [AWG] (Note 2)			
	L1/L2/L3/⊕	L11/L21	P+/C	U/V/W/⊕ (Note 3)
MR-J4-10_/MR-J4-20_/MR-J4-40_/MR-J4-60_/MR-J4-70_/MR-J4-100_	14	14	14	14
MR-J4-200_	12			12
MR-J4-350_	10	14: c	14: c	8: b
MR-J4-500_ (Note 1)	8: b			12: a
MR-J4-700_ (Note 1)				12: e
MR-J4-11K_ (Note 1)				10: e
MR-J4-15K_ (Note 1)				10: i
MR-J4-22K_ (Note 1)	1/0: h	14	14	2/0: j
MR-J4W_-B	14 (Note 4)	14	14	14

- Note
1. To connect these models to a terminal block, be sure to use the screws that come with the terminal block.
 2. Alphabets in the table indicate crimping tools. Refer to the following table for the crimp terminals and crimping tools.
 3. Select wire sizes depending on the rated output of the servo motors. The values in the table are sizes based on rated output of the servo amplifiers.
 4. Use the crimp terminal c for the PE terminal of the servo amplifier.

Table: Recommended crimp terminals

Symbol	Servo amplifier-side crimp terminals				Manufacturer
	Crimp terminal (Note 2)	Applicable tool			
		Body	Head	Dice	
a	FVD5.5-4	YNT-1210S	/	/	JST
b (Note 1)	8-4NS	YHT-8S			
c	FVD2-4	YNT-1614			
d	FVD14-6	YF-1	YNE-38	DH-122/DH-112	
e	FVD5.5-6	YNT-1210S	/	/	
f	FVD22-6	YF-1			
g	FVD38-6	YF-1	YNE-38	DH-124/DH-114	
h	R60-8	YF-1	YET-60-1	TD-125/TD-113	
i	FVD5.5-8	YNT-1210S	/	/	
j	CB70-S8	YF-1			

- Note 1. Coat the crimping part with an insulation tube.
 Note 2. Some crimp terminals may not be mounted depending on the size. Make sure to use the recommended ones or equivalent ones.

(b) Selection example of MCCB and fuse

When a servo amplifier is protected by T class fuses or circuit breaker having an interrupting rating not less than 300 A effective value and 240 V maximum, use T class fuses or molded-case circuit breaker (UL489 Listed MCCB) as the following table. The T class fuses and molded-case circuit breakers in the table are selected examples based on rated I/O of the servo amplifiers. When you select a smaller capacity servo motor to connect it to the servo amplifier, you can also use smaller capacity T class fuses or molded-case circuit breaker than ones in the table. For selecting ones other than Class T fuses and molded-case circuit breakers below, refer to section 11.6.

Servo amplifier	Molded-case circuit breaker (240 V AC)	Fuse (300 V)
MR-J4-10_/MR-J4-20_/MR-J4-40_/MR-J4-60_/MR-J4-70_/MR-J4W2-22B	NF50-SVFU-5A (50 A frame 5 A)	10 A
MR-J4-60_ (Note) /MR-J4-70_ (Note)/MR-J4-100_/MR-J4W2-22B (Note) /MR-J4W2-44B/MR-J4W2-77B/MR-J4W3-222B/MR-J4W3-444B	NF50-SVFU-10A (50 A frame 10 A)	15 A
MR-J4-200_/MR-J4W2-44B (Note)/MR-J4W2-1010B	NF50-SVFU-15A (50 A frame 15 A)	30 A
MR-J4-350_/MR-J4W2-77B (Note)/MR-J4W3-444B (Note)	NF50-SVFU-20A (50 A frame 20 A)	40 A
MR-J4-500_	NF50-SVFU-30A (50 A frame 30 A)	60 A
MR-J4-700_	NF50-SVFU-40A (50 A frame 40 A)	80 A
MR-J4-11K_	NF100-CVFU-60A (100 A frame 60 A)	125 A
MR-J4-15K_	NF100-CVFU-80A (100 A frame 80 A)	150 A
MR-J4-22K_	NF225-CWU-125A (225 A frame 125 A)	300 A

Note. For 1-phase 200 V AC power input

(c) Power supply

This servo amplifier can be supplied from star-connected supply with grounded neutral point of overvoltage category III set forth in IEC/EN 60664-1. However, when you use the neutral point for single phase supply, a reinforced insulating transformer is required in the power input section. For the interface power supply, use an external 24 V DC power supply with reinforced insulation on I/O terminals.

APPENDIX

(d) Grounding

To prevent an electric shock, always connect the protective earth (PE) terminal (marked \oplus) of the servo amplifier to the protective earth (PE) of the cabinet. Do not connect two grounding cables to the same protective earth (PE) terminal. Always connect cables to the terminals one-to-one. If using an earth-leakage current breaker, always ground the protective earth (PE) terminal of the servo amplifier to prevent an electric shock. Only an RCD (earth-leakage current breaker) of type B can be used for the power supply side of the product.



(2) EU compliance

The MR-J4 servo amplifiers are designed to comply with the following directions to meet requirements for mounting, using, and periodic technical inspections: Machinery directive (2006/42/EC), EMC directive (2004/108/EC), and Low-voltage directive (2006/95/EC).

(a) EMC requirement

MR-J4 servo amplifiers comply with category C3 in accordance with IEC/EN 61800-3. As for I/O wires (max. length 10 m. However, 3 m for STO cable for CN8.) and encoder cables (max. length 50 m), connect them to a shielded grounding. Use a EMC filter and surge protector on the primary side. The following shows recommended products.

EMC filter: Soshin Electric HF3000A-UN series

Surge protector: Okaya Electric Industries RSPD-250-U4 series

- MR-J4 Series are not intended to be used on a low-voltage public network which supplies domestic premises;
- radio frequency interference is expected if used on such a network.

The installer shall provide a guide for Installation and use, including recommended mitigation devices.

(b) For Declaration of Conformity (DoC)

Hereby, MITSUBISHI ELECTRIC EUROPE B.V., declares that the servo amplifiers are in compliance with the necessary requirements and standards (2006/42/EC, 2004/108/EC and 2006/95/EC). For the copy of Declaration of Conformity, contact your local sales office.

(3) USA/Canada compliance

This servo amplifier is designed in compliance with UL 508C and CSA C22.2 No.14 standards. Refer to MR-J4 Servo Amplifier Instruction Manuals for details of UL/CSA standards.

(a) Installation

The minimum cabinet size is 150% of each MR-J4 servo amplifier's volume. Also, design the cabinet so that the ambient temperature in the cabinet is 55 °C or less. The servo amplifier must be installed in a metal cabinet. Environment is open type (UL 50) and overvoltage category III. The servo amplifier needs to be installed at or below of pollution degree 2. Use copper conductors only.

(b) Short-circuit current rating (SCCR)

Suitable For Use On A Circuit Capable Of Delivering Not More Than 100 kA rms Symmetrical Amperes, 500 Volts Maximum.

APPENDIX

(c) Overload protection characteristics

The MR-J4 servo amplifiers have servo motor overload protective function. (It is set on the basis (full load current) of 120% rated current of the servo amplifier.)

(d) Over-temperature protection for motor

Motor Over temperature sensing is not provided by the drive.

(e) Capacitor discharge

It takes 15 minutes for capacitor discharging. Do not touch the unit and terminals immediately after power off.

(f) Branch circuit protection

For installation in United States, branch circuit protection must be provided, in accordance with the National Electrical Code and any applicable local codes.

For installation in Canada, branch circuit protection must be provided, in accordance with the Canada Electrical Code and any applicable provincial codes.

(4) South Korea compliance

This product complies with the Radio Wave Law (KC mark). Please note the following to use the product.

이 기기는 업무용 (A급) 전자파적합기기로서 판매자 또는 사용자는 이 점을 주의하시기 바라며, 가정외의 지역에서 사용하는 것을 목적으로 합니다.

(The product is for business use (Class A) and meets the electromagnetic compatibility requirements. The seller and the user must note the above point, and use the product in a place except for home. In addition, use an EMC filter, surge protector, and line noise filter on the primary side for inputs. Use a line noise filter for outputs.)

App. 4.2.4 General cautions for safety protection and protective measures

Observe the following items to ensure proper use of the MELSERVO MR-J4 servo amplifiers.

- (1) For safety components and installing systems, only qualified personnel and professional engineers should perform.
- (2) When mounting, installing, and using the MELSERVO MR-J4 servo amplifier, always observe standards and directives applicable in the country.
- (3) The item about noises of the test notices in the manuals should be observed.
- (4) The MR-J4 servo amplifiers fulfill the requirements to conducted emissions at the main connections in the frequency range from 150 kHz to 30 MHz. (Bases for the evaluation: Product standard IEC/EN 61800, adjustable speed electrical power drive systems, Part 3: EMC)

App. 4.2.5 Residual risk

- (1) Be sure that all safety related switches, relays, sensors, etc., meet the required safety standards.
- (2) Perform all risk assessments and safety level certification to the machine or the system as a whole.
- (3) If the upper and lower power modules in the servo amplifier are shorted and damaged simultaneously, the servo motor may make a half revolution at a maximum.

APPENDIX

- (4) Only qualified personnel are authorized to install, start-up, repair or service the machines in which these components are installed. Only trained engineers should install and operate the equipment. (ISO 13849-1 Table F.1 No.5)
- (5) Separate the wiring for safety function from other signal wirings. (ISO 13849-1 Table F.1 No.1)
- (6) Protect the cables with appropriate ways (routing them in a cabinet, using a cable guard, etc.).
- (7) Keep the required clearance/creepage distance depending on voltage you use.

App. 4.2.6 Disposal

Disposal of unusable or irreparable devices should always occur in accordance with the applicable country-specific waste disposal regulations. (Example: European Waste 16 02 14)

App. 4.2.7 Lithium battery transportation

To transport lithium batteries, take actions to comply with the instructions and regulations such as the United Nations (UN), the International Civil Aviation Organization (ICAO), and the International Maritime Organization (IMO).

The battery options (MR-BAT6V1SET and MR-BAT6V1) are assembled batteries from lithium metal battery CR17335A which are not subject to the dangerous goods (Class 9) of the UN Recommendations.

App. 4.3 Mounting/dismounting

Installation direction and clearances

 CAUTION	<ul style="list-style-type: none">● The devices must be installed in the specified direction. Not doing so may cause a malfunction.● Mount the servo amplifier on a cabinet which meets IP54 in the correct vertical direction to maintain pollution degree 2.
--	---

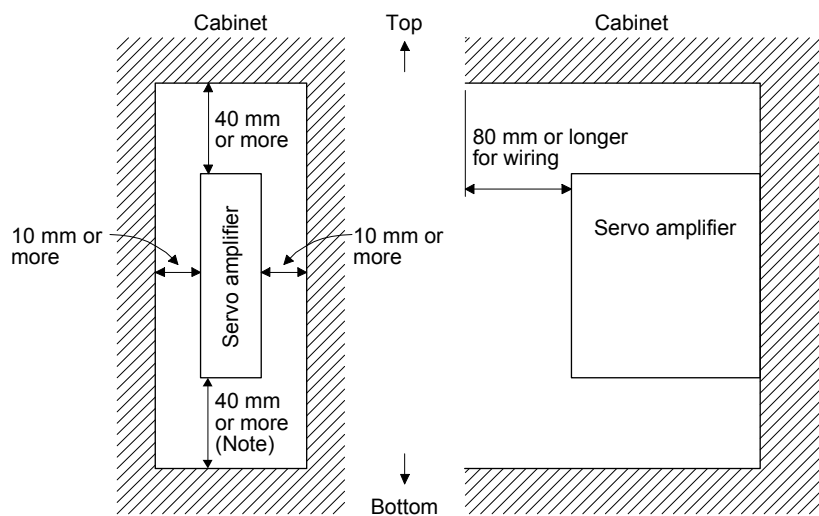

Note. For 11 kW to 22 kW servo amplifiers, the clearance between the bottom and ground will be 120 mm or more.

APPENDIX

App. 4.4 Electrical Installation and configuration diagram

⚠ WARNING ● Turn off the molded-case circuit breaker (MCCB) to avoid electrical shocks or damages to the product before starting the installation or wiring.

⚠ CAUTION ● The installation complies with IEC/EN 60204-1. The voltage supply to machines must be 20 ms of immunity to instantaneous power failures as specified in IEC/EN 60204-1.

The following shows representative configuration diagram examples to conform to the IEC/EN/UL/CSA standards.

(1) 3-phase input for MR-J4 1-axis servo amplifier

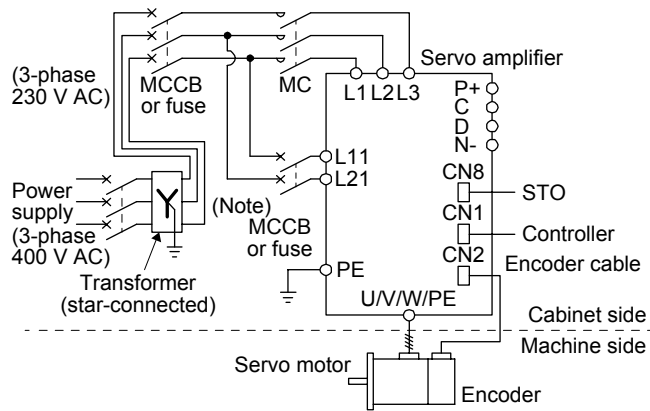

(2) 1-phase input for MR-J4 1-axis servo amplifier

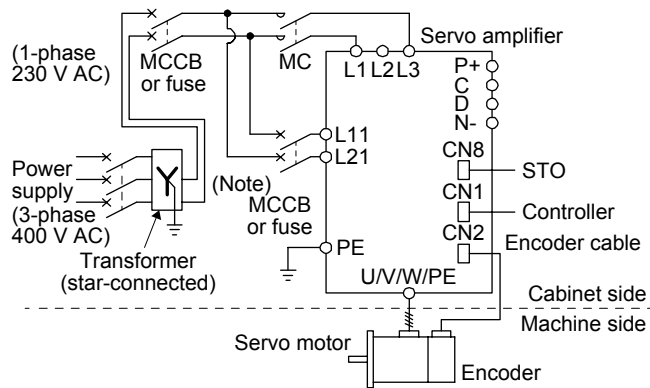

APPENDIX

(3) 3-phase input for MR-J4 multi-axis servo amplifier

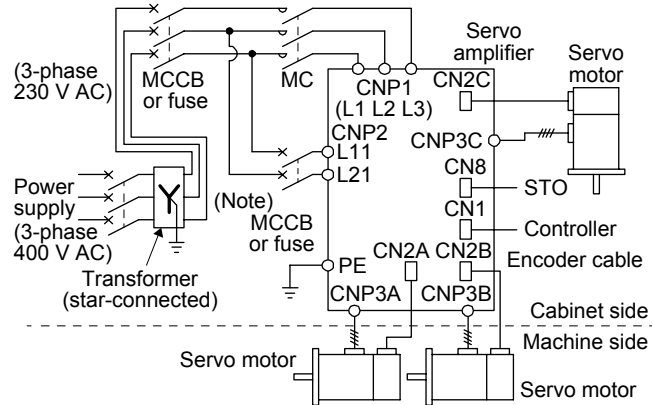

(4) 1-phase input for MR-J4 multi-axis servo amplifier

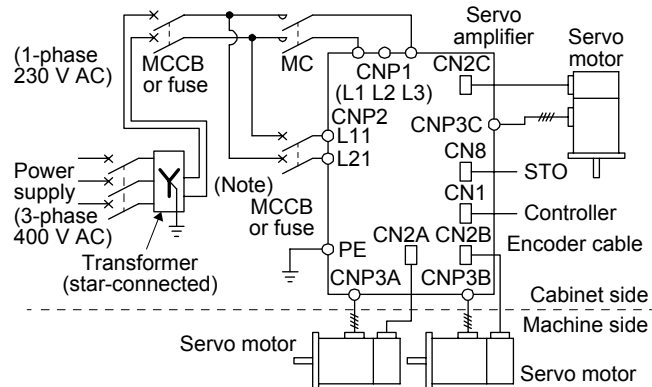

Note. When the wire sizes of L1 and L11 are the same, MCCB or fuse is not required.

The control circuit connectors described by rectangles are safely separated from the main circuits described by circles.

The connected motors will be limited as follows.

- (1) HG/HF/HC/HA series servo motors (Mfg.: Mitsubishi Electric)
- (2) Using a servo motor complied with IEC60034-1 and Mitsubishi Electric encoder (OBA, OSA)

APPENDIX

App. 4.5 Signal

App. 4.5.1 Signal

The following shows MR-J4-10B signals as a typical example. Refer to section 3.4 for the MR-J4W__B servo amplifiers.

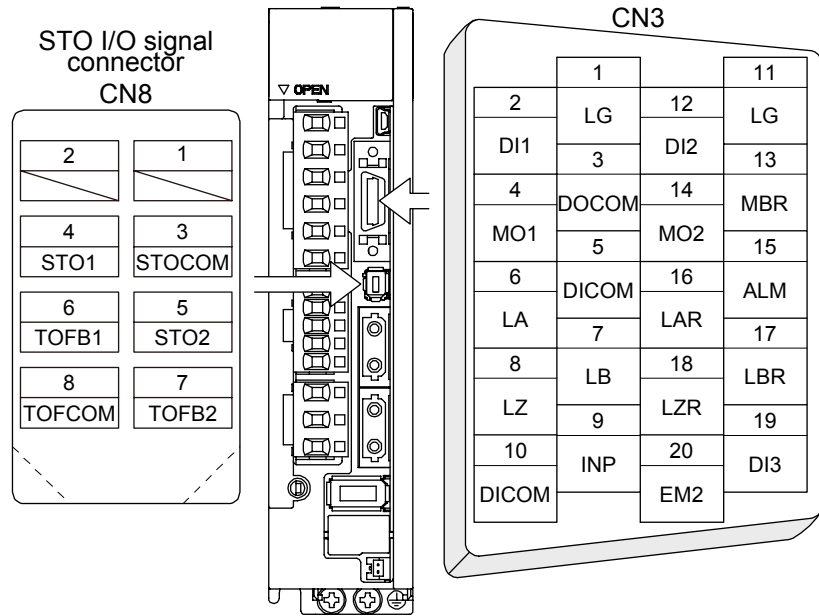

App. 4.5.2 I/O device

Input device

Symbol	Device	Connector	Pin No.
EM2	Forced stop 2	CN3	20
STOCOM	Common terminal for input signals STO1/STO2	CN8	3
STO1	STO1 state input		4
STO2	STO2 state input		5

Output device

Symbol	Device	Connector	Pin No.
TOFCOM	Common terminal for monitor output signal in STO state	CN8	8
TOFB1	Monitor output signal in STO1 state		6
TOFB2	Monitor output signal in STO2 state		7

Power supply

Symbol	Device	Connector	Pin No.
DICOM	Digital I/F power supply input	CN3	5, 10
DOCOM	Digital I/F common		3
SD	Shield		Plate

APPENDIX

App. 4.6 Maintenance and service

 WARNING	<ul style="list-style-type: none"> ● To avoid an electric shock, only qualified personnel should attempt inspections. For repair and parts replacement, contact your local sales office.
--	---

 CAUTION	<ul style="list-style-type: none"> ● Do not perform insulation resistance test on the servo amplifier. Otherwise, it may cause a malfunction. ● Do not disassemble and/or repair the equipment on customer side.
--	--

App. 4.6.1 Inspection items

It is recommended that the following points periodically be checked.

(1) Check for loose terminal block screws. Retighten any loose screws.

Servo amplifier	Tightening torque [N•m]															
	L1	L2	L3	N-	P3	P4	P+	C	D	L11	L21	U	V	W	PE	
MR-J4-10_/MR-J4-20_ MR-J4-40_/MR-J4-60_ MR-J4-70_/MR-J4-100_ MR-J4-200_/MR-J4-350_	/														1.2	
MR-J4-500_	1.2								/		0.8		1.2			
MR-J4-700_	1.2								/		0.8		1.2			
MR-J4-11K_/MR-J4-15K_	3.0								/		1.2		3.0			
MR-J4-22K_	6.0								/		1.2		6.0			
MR-J4W_-B	/														1.2	

(2) Servo motor bearings, brake section, etc. for unusual noise.

(3) Check the cables and the like for scratches or cracks. Perform periodic inspection according to operating conditions.

(4) Check that the connectors are securely connected to the servo motor.

(5) Check that the wires are not coming out from the connector.

(6) Check for dust accumulation on the servo amplifier.

(7) Check for unusual noise generated from the servo amplifier.

(8) Check the servo motor shaft and coupling for connection.

APPENDIX

App. 4.6.2 Parts having service lives

Service lives of the following parts are listed below. However, the service life vary depending or operating methods and environment. If any fault is found in the parts, they must be replaced immediately regardless of their service lives. For parts replacement, please contact your local sales office.

Part name		Life guideline	
Smoothing capacitor		(Note 4) 10 years	
Relay		Number of power-on, forced stop and controller forced stop times: 100 000 times Number of on and off for STO: 1,000,000 times	
Cooling fan		10,000 hours to 30,000 hours (2 years to 3 years)	
Battery backup time	(Note 1) MR-J4 1-axis servo amplifier	Rotary servo motor	Approximately 20,000 hours (equipment power supply: off, ambient temperature: 20 °C)
		Direct drive motor	Approximately 5,000 hours (equipment power supply: off, ambient temperature: 20 °C)
	(Note 2) MR-J4 multi-axis servo amplifier	Rotary servo motor	Approximately 40,000 hours for 2-axis, 30,000 hours for 3-axis, or 10,000 hours for 8-axis, (equipment power supply: off, ambient temperature: 20 °C)
		Direct drive motor	Approximately 10,000 hours for 2-axis, 7,000 hours for 3-axis, or 2,000 hours for 8-axis, (equipment power supply: off, ambient temperature: 20 °C)
(Note 3) Battery life		5 years from date of manufacture	

- Note 1. The data-holding time using a battery of MR-BAT6V1SET on condition that the power supply of the servo amplifier is off. Replace the batteries within three years since the operation start whether the power supply of the servo amplifier is on/off. If the battery is used out of specification, [AL. 25 Absolute position erased] may occur.
2. The data-holding time using 5 batteries of MR-BAT6V1 on condition that the power supply of the servo amplifier is off. Replace the batteries within three years since the operation start whether the power supply of the servo amplifier is on/off. If the battery is used out of specification, [AL. 25 Absolute position erased] may occur.
3. Quality of the batteries degrades by the storage condition. The battery life is 5 years from the production date regardless of the connection status.
4. The characteristic of smoothing capacitor is deteriorated due to ripple currents, etc. The life of the capacitor greatly depends on ambient temperature and operating conditions. The capacitor will reach the end of its life in 10 years of continuous operation in normal air-conditioned environment (40 °C surrounding air temperature or less).

APPENDIX

App. 4.7 Transportation and storage

	CAUTION	<ul style="list-style-type: none"> ● Transport the products correctly according to their mass. ● Stacking in excess of the limited number of product packages is not allowed. ● Do not hold the front cover to transport the servo amplifier. Otherwise, it may drop. ● Install the servo amplifier and servo motor in a load-bearing place in accordance with the Instruction Manual. ● Do not get on or put heavy load on the equipment. ● For detailed information on the option battery's transportation and handing, refer to app. 2.
---	---------	--

When you keep or use it, please fulfill the following environment.

Item		Environment
Ambient temperature	Operation [°C]	0 to 55 Class 3K3 (IEC/EN 60721-3-3)
	Transportation (Note) [°C]	-20 to 65 Class 2K4 (IEC/EN 60721-3-2)
	Storage (Note) [°C]	-20 to 65 Class 1K4 (IEC/EN 60721-3-1)
Ambient humidity	Operation, transportation, storage	5% to 90 %RH
Vibration load	Test values	10 Hz to 57 Hz with constant deviation of 0.075 mm 57 Hz to 150 Hz with constant acceleration of 9.8 m/s ² (1 g) to IEC/EN 61800-5-1 (Test Fc of IEC 60068-2-6)
	Operation	5.9 m/s ² (0.6 g)
	Transportation (Note)	Class 2M3 (IEC/EN 60721-3-2)
	Storage	Class 1M2 (IEC/EN 60721-3-2)
Pollution degree		2
IP rating		Except terminal block IP20 (IEC/EN 60529) and fan finger guard Open type (UL 50)
Altitude	Operation, storage	1000 m or less above sea level
	Transportation	10000 m or less above sea level

Note. In regular transport packaging

APPENDIX

App. 4.8 Technical data

App. 4.8.1 MR-J4 servo amplifier

Item		MR-J4-10_/MR-J4-20_/MR-J4-40_/MR-J4-60_/MR-J4-70_/MR-J4W2-22B/MR-J4W2-44B/MR-J4W2-77B/MR-J4W3-222B/MR-J4W3-444B	MR-J4-100_/MR-J4-200_/MR-J4-350_/MR-J4-500_/MR-J4-700_/MR-J4W2-1010B/MR-J4-11K_/MR-J4-15K_/MR-J4-22K_
Power supply	Main circuit (line voltage)	3-phase or 1-phase 200 V AC to 240 V AC, 50 Hz/60 Hz	3-phase 200 V AC to 240 V AC, 50 Hz/60 Hz
	Control circuit (line voltage)	1-phase 200 V AC to 240 V AC, 50 Hz/60 Hz	
	Interface (SELV)	24 V DC, (required current capacity: MR-J4-_A, 500 mA; MR-J4-_B, 300 mA; MR-J4W2-_B, 350 mA; MR-J4W3-_B, 450 mA)	
Control method		Sine-wave PWM control, current control method	
Safety function (STO) IEC/EN 61800-5-2		EN ISO 13849-1 category 3 PL d, EN 61508 SIL 2, EN 62061 SIL CL 2, and EN 61800-5-2 SIL 2	
Mean time to dangerous failure		MTTFd = 100 [years]	
Effectiveness of fault monitoring of a system or subsystem		DC = 90 [%]	
Average probability of dangerous failures per hour		PFH = 1.68×10^{-10} [1/h]	
Mission time		TM = 20 [years]	
Response performance		8 ms or less (STO input off → energy shut off)	
Pollution degree		2 (IEC/EN 60664-1)	
Overvoltage category		III (IEC/EN 60664-1)	
Protection class		I (IEC/EN 61800-5-1)	
Short-circuit current rating (SCCR)		100 kA	

APPENDIX

App. 4.8.2 Servo amplifier dimensions

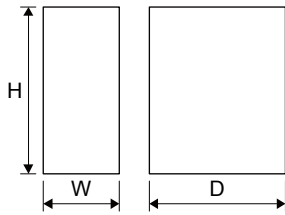

Servo amplifier	Variable dimension table [mm]			Mass [kg]
	W	H	D	
MR-J4-10_/MR-J4-20_	40	168	135	0.8
MR-J4-40_/MR-J4-60_	40	168	170	1.0
MR-J4-70_/MR-J4-100_	60	168	185	1.4
MR-J4-200_	90	168	195	2.1
MR-J4-350_	90	168	195	2.3
MR-J4-500_	105	250	200	4.0
MR-J4-700_	172	300	200	6.2
MR-J4-11K_/MR-J4-15K_	220	400	260	13.4
MR-J4-22K_	260	400	260	18.2
MR-J4W2-22B/MR-J4W2-44B	60	168	195	1.4
MR-J4W2-77B/MR-J4W2-1010B	85	168	195	2.3
MR-J4W3-222B/MR-J4W3-444B	85	168	195	2.3

App. 4.8.3 Mounting hole

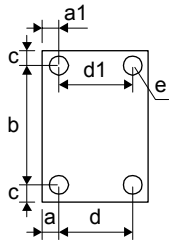

Servo amplifier	Variable dimensions [mm]						Screw size
	a	a1	b	c	d	d1	e
MR-J4-10_/MR-J4-20_/MR-J4-40_/MR-J4-60_	6	6	156 ± 0.5	6			M5
MR-J4-70_/MR-J4-100_	12	12	156 ± 0.5	6	42 ± 0.3		M5
MR-J4-200_/MR-J4-350_	6	45	156 ± 0.5	6	78 ± 0.3		M5
MR-J4-500_	6	6	235 ± 0.5	7.5	93 ± 0.3	93 ± 0.3	M5
MR-J4-700_	6	6	285 ± 0.5	7.5	160 ± 0.5	160 ± 0.5	M5
MR-J4-11K_/MR-J4-15K_	12	12	380 ± 0.5	10	196 ± 0.5	196 ± 0.5	M5
MR-J4-22K_	12	12	376 ± 0.5	12	236 ± 0.5	236 ± 0.5	M10
MR-J4W2-22B/MR-J4W2-44B	6	6	156 ± 0.5	6			M5
MR-J4W2-77B/MR-J4W2-1010B	6	6	156 ± 0.5	6	73 ± 0.3		M5
MR-J4W3-222B/MR-J4W3-444B	6	6	156 ± 0.5	6	73 ± 0.3		M5

App. 4.9 Check list for user documentation



MR-J4 installation checklist for manufacturer/installer

The following items must be satisfied by the initial test operation at least. The manufacturer/installer must be responsible for checking the standards in the items.

Maintain and keep this checklist with related documents of machines to use this for periodic inspection.

1. Is it based on directive/standard applied to the machine? Yes [], No []
2. Is directive/standard contained in Declaration of Conformity (DoC)? Yes [], No []
3. Does the protection instrument conform to the category required? Yes [], No []
4. Are electric shock protective measures (protection class) effective? Yes [], No []
5. Is the STO function checked (test of all the shut-off wiring)? Yes [], No []

Checking the items will not be instead of the first test operation or periodic inspection by professional engineers.

APPENDIX

App. 5 MR-J3-D05 Safety logic unit

App. 5.1 Contents of the package

Open packing, and confirm the content of packing.

Contents	Quantity
MR-J3-D05 Safety logic unit	1
Connector for CN9 1-1871940-4 (TE Connectivity)	1
Connector for CN10 1-1871940-8 (TE Connectivity)	1
MR-J3-D05 Safety Logic Unit Installation Guide	1

App. 5.2 Terms related to safety

App. 5.2.1 Stop function for IEC/EN 61800-5-2

(1) STO function (Refer to IEC/EN 61800-5-2: 2007 4.2.2.2 STO.)

This function is integrated into the MR-J4 series servo amplifiers.

The STO function shuts down energy to servo motors, thus removing torque. This function electronically cuts off power supply in servo amplifiers for MR-J4 series servo amplifiers.

The purpose of this safety function is as follows.

- 1) Uncontrolled stop according to stop category 0 of IEC/EN 60204-1
- 2) Preventing unexpected start-up

(2) SS1 function (Refer to IEC/EN 61800-5-2: 2007 4.2.2.3C Safe stop 1 temporal delay.)

SS1 is a function which initiates the STO function when the previously set delay time has passed after the servo motor starts decelerating. The delay time can be set with MR-J3-D05.

The purpose of this safety function is as follows. This function is available by using an MR-J4 series servo amplifier with MR-J3-D05.

- Controlled stop according to stop category 1 of IEC/EN 60204-1

App. 5.2.2 Emergency operation for IEC/EN 60204-1

(1) Emergency stop (Refer to IEC/EN 60204-1: 2005 9.2.5.4.2 Emergency Stop.)

Emergency stop must override all other functions and actuation in all operation modes. Power to the machine driving part which may cause a hazardous state must be either removed immediately (stop category 0) or must be controlled to stop such hazardous state as soon as possible (stop category 1). Restart must not be allowed even after the cause of the emergency state has been removed.

(2) Emergency switching off (Refer to IEC/EN 60204-1: 2005 9.2.5.4.3 Emergency Switching OFF.)

Removal of input power to driving device to remove electrical risk and to meet above mentioned safety standards.

APPENDIX

App. 5.3 Cautions

The following basic safety notes must be read carefully and fully in order to prevent injury to persons or damage to property.

Only qualified personnel are authorized to install, start-up, repair or service the machines in which these components are installed.

They must be familiar with all applicable local safety regulations and laws in which machines with these components are installed, particularly the standards and guidelines mentioned in this Instruction Manual and the requirements mentioned in ISO/EN ISO 13849-1, IEC/EN 61508, IEC/EN 61800-5-2, and IEC/EN 60204-1.

The staff responsible for this work must be given express permission from the company to perform start-up, programming, configuration, and maintenance of the machine in accordance with the safety standards.

	WARNING	● Improper installation of the safety related components or systems may cause improper operation in which safety is not assured, and may result in severe injuries or even death.
---	----------------	---

Protective Measures

- As described in IEC/EN 61800-5-2, the Safe Torque Off (STO) function only prevents the MFR-J4 series servo amplifier from supplying energy to the servo motor. Therefore, if an external force acts upon the drive axis, additional safety measures, such as brakes or counter-weights must be used.

App. 5.4 Residual risk

Machine manufacturers are responsible for all risk evaluations and all associated residual risks. Below are residual risks associated with the STO/EMG function. Mitsubishi is not liable for any damages or injuries caused by the residual risks.

- (1) The SS1 function only guarantees the delay time before STO/EMG is engaged. Proper setting of this delay time is the full responsibility of the company and/or individuals responsible for installation and commissioning of the safety related system. The system, as a whole, must pass safety standards certification.
- (2) When the SS1 delay time is shorter than the required servo motor deceleration time, if the forced stop function is malfunctioning, or if STO/EMG is engaged while the servo motor is still rotating; the servo motor will stop with the dynamic brake or freewheeling.
- (3) For proper installation, wiring, and adjustment, thoroughly read the manual of each individual safety related component.
- (4) Be sure that all safety related switches, relays, sensors, etc., meet the required safety standards. The Mitsubishi Electric safety related components mentioned in this manual are certified by Certification Body as meeting the requirements of ISO/EN ISO 13849-1 Category 3, PL d and EN 61508 SIL 2.
- (5) Safety is not assured until safety-related components of the system are completely installed or adjusted.
- (6) When replacing a MR-J4 series servo amplifier or MR-J3-D05, confirm that the new device is exactly the same model as those being replaced.

APPENDIX

- (7) Perform all risk assessments and safety level certification to the machine or the system as a whole. It is recommended that a Certification Body final safety certification of the system be used.
- (8) To prevent accumulation of multiple malfunctions, perform a malfunction check at regular intervals as deemed necessary by the applicable safety standard. Regardless of the system safety level, malfunction checks should be performed at least once per year.
- (9) If the upper and lower power module in the servo amplifier are shorted and damaged simultaneously, the servo motor may make a half revolution at a maximum. For a linear servo motor, the primary side will move a distance of pole pitch.

App. 5.5 Block diagram and timing chart

(1) Function block diagram

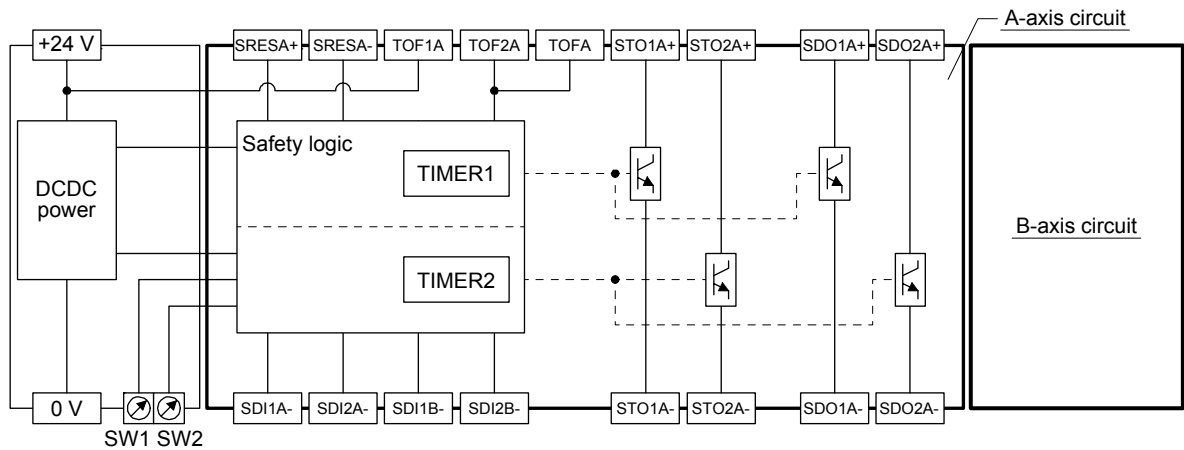

(2) Operation sequence

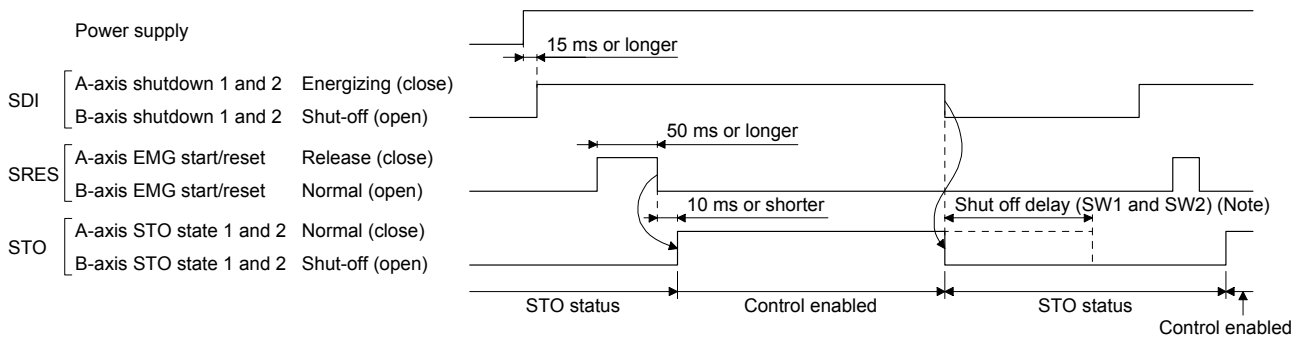

Note. Refer to App. 5.10.

App. 5.6 Maintenance and disposal

MR-J3-D05 safety logic unit is equipped with LED displays to check errors for maintenance. Please dispose this unit according to your local laws and regulations.

App. 5.7 Functions and configuration

App. 5.7.1 Summary

MR-J3-D05 has two systems in which the each system has SS1 function (delay time) and output of STO function.

APPENDIX

App. 5.7.2 Specifications

Safety logic unit model		MR-J3-D05
Control circuit power supply	Voltage	24 V DC
	Permissible voltage fluctuation	24 V DC \pm 10%
	Power supply capacity [A]	0.5 (Note 1, 2)
Compatible system		2 systems (A-axis, B-axis independent)
Shut-off input		4 points (2 points \times 2 systems) SDI_: (source/sink compatible) (Note 3)
Shut-off release input		2 points (1 point \times 2 systems) SRES_: (source/sink compatible) (Note 3)
Feedback input		2 points (1 point \times 2 systems) TOF_: (source compatible) (Note 3)
Input type		Photocoupler insulation, 24 V DC (external supply), internal limited resistance 5.4 k Ω
Shut-off output		8 points (4 point \times 2 systems) STO_: (source compatible) (Note 3) SDO_: (source/sink compatible) (Note 3)
Output method		Photocoupler insulation, open-collector type Permissible current: 40 mA/1 output, Inrush current: 100 mA/1 output
Delay time setting		A-axis: Select from 0 s, 1.4 s, 2.8 s, 5.6 s, 9.8 s, or 30.8 s. B-axis: Select from 0 s, 1.4 s, 2.8 s, 9.8 s, or 30.8 s. Accuracy: \pm 2%
Safety function		STO, SS1 (IEC/EN 61800-5-2) EMG STOP, EMG OFF IEC/EN 60204-1
Safety performance	Standards certified by CB	EN ISO 13849-1 category 3 PL d, EN 61508 SIL 2, EN 62061 SIL CL 2, and EN 61800-5-2 SIL 2
	Response performance (when delay time is set to 0 s) (Note 4)	10 ms or less (STO input off \rightarrow shut-off output off)
	Mean time to dangerous failure (MTTFd)	516 years
	Diagnosis converge (DC avg)	93.1%
	Average probability of dangerous failures per hour (PFH)	4.75×10^{-9} [1/h]
Compliance to standards	CE marking	LVD: EN 61800-5-1 EMC: EN 61800-3 MD: EN ISO 13849-1, EN 61800-5-2, EN 62061
Structure		Natural-cooling, open (IP rating: IP 00)
Environment	Ambient temperature	0 °C to 55 °C (non-freezing), storage: -20 °C to 65 °C (non-freezing)
	Ambient humidity	90 %RH or less (non-condensing), storage: 90 %RH or less (non-condensing)
	Ambience	Indoors (no direct sunlight), free from corrosive gas, flammable gas, oil mist, dust, and dirt
	Altitude	Max. 1000 m above sea level
	Vibration resistance	5.9 m/s ² at 10 Hz to 55 Hz (directions of X, Y, and Z axes)
Mass	[kg]	0.2 (including CN9 and CN10 connectors)

- Note 1. Inrush current of approximately 1.5 A flows instantaneously when turning the control circuit power supply on. Select an appropriate capacity of power supply considering the inrush current.
2. Power-on duration of the safety logic unit is 100,000 times.
3. _ : in signal name indicates a number or axis name.
4. For the test pulse input, contact your local sales office.

APPENDIX

App. 5.7.3 When using MR-J3-D05 with an MR-J4 series servo amplifier

(1) System configuration diagram

POINT
●MR-D05UDL_M (STO cable) for MR-J3 series cannot be used.

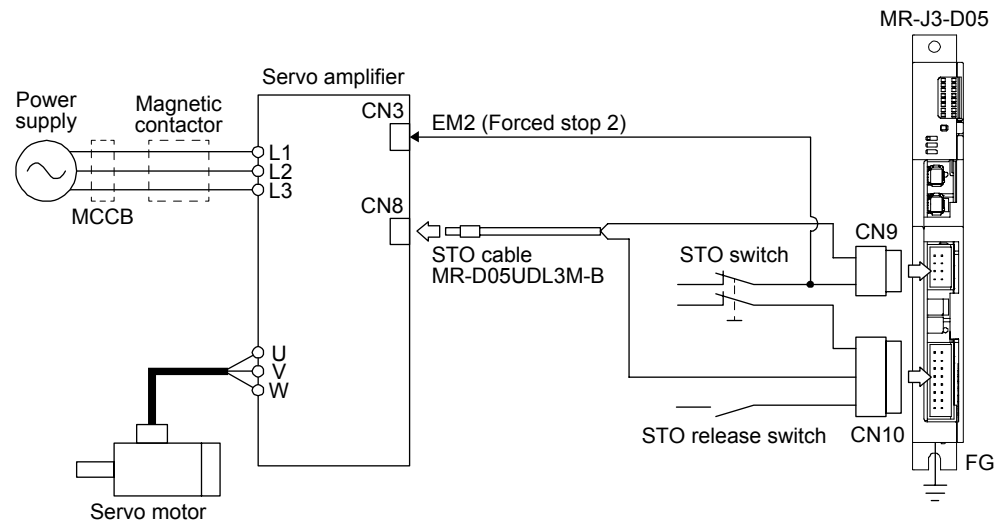

APPENDIX

(2) Connection example

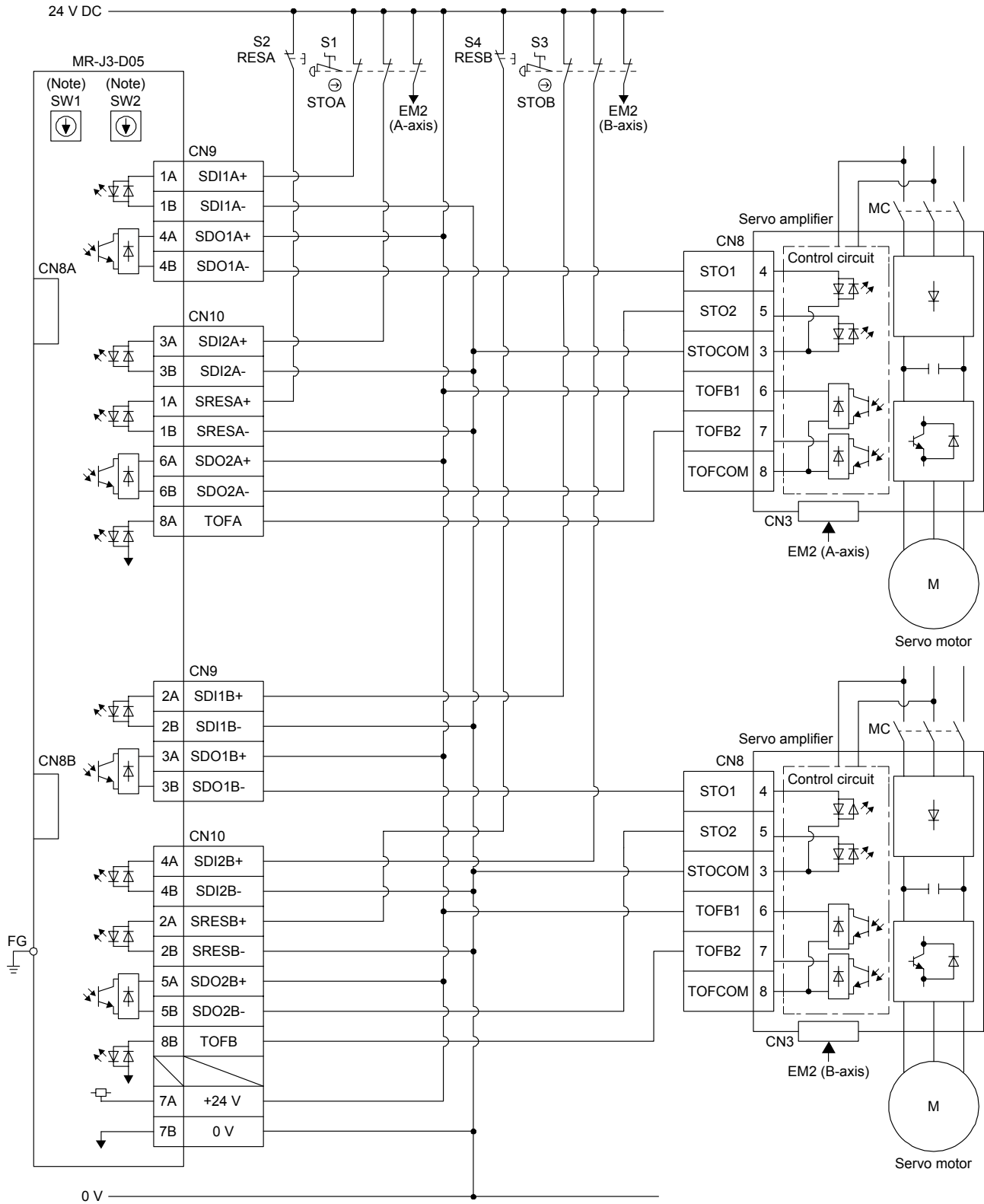

Note. Set the delay time of STO output with SW1 and SW2. These switches are located where dented from the front panel.

APPENDIX

App. 5.8 Signal

App. 5.8.1 Connector/pin assignment

(1) CN8A

Device	Symbol	Pin No.	Function/Application	I/O division
A-axis STO1	STO1A- STO1A+	1	Outputs STO1 to A-axis driving device.	O
		4	Outputs the same signal as A-axis STO2. STO state (base shutdown): Between STO1A+ and STO1A- is opened. STO release state (in driving): Between STO1A+ and STO1A- is closed.	
A-axis STO2	STO2A- STO2A+	5	Outputs STO2 to A-axis driving device.	O
		6	Outputs the same signal as A-axis STO1. STO state (base shutdown): Between STO2A+ and STO2A- is opened. STO release state (in driving): Between STO2A+ and STO2A- is closed.	
A-axis STO state	TOF2A TOF1A	7	Inputs STO state of A-axis driving device.	I
		8	STO state (base shutdown): Open between TOF2A and TOF1A. STO release state (in driving): Close between TOF2A and TOF1A.	

(2) CN8B

Device	Symbol	Pin No.	Function/Application	I/O division
B-axis STO1	STO1B- STO1B+	1	Outputs STO1 to B-axis driving device.	O
		4	Outputs the same signal as B-axis STO2. STO state (base shutdown): Between STO1B+ and STO1B- is opened. STO release state (in driving): Between STO1B+ and STO1B- is closed.	
B-axis STO2	STO2B- STO2B+	5	Outputs STO2 to B-axis driving device.	O
		6	Outputs the same signal as B-axis STO1. STO state (base shutdown): Between STO2B+ and STO2B- is opened. STO release state (in driving): Between STO2B+ and STO2B- is closed.	
B-axis STO state	TOF2B TOF1B	7	Inputs STO state of B-axis driving device.	I
		8	STO state (base shutdown): Open between TOF2B and TOF1B. STO release state (in driving): Close between TOF2B and TOF1B.	

(3) CN9

Device	Symbol	Pin No.	Function/Application	I/O division
A-axis shutdown 1	SDI1A+ SDI1A-	1A	Connect this device to a safety switch for A-axis driving device.	DI-1
		1B	Input the same signal as A-axis shutdown 2. STO state (base shutdown): Open between SDI1A+ and SDI1A-. STO release state (in driving): Close between SDI1A+ and SDI1A-.	
B-axis shutdown 1	SDI1B+ SDI1B-	2A	Connect this device to a safety switch for B-axis driving device.	DI-1
		2B	Input the same signal as B-axis shutdown 2. STO state (base shutdown): Open between SDI1B+ and SDI1B-. STO release state (in driving): Close between SDI1B+ and SDI1B-.	
A-axis SDO1	SDO1A+ SDO1A-	4A	Outputs STO1 to A-axis driving device.	DO-1
		4B	Outputs the same signal as A-axis SDO2. STO state (base shutdown): Between SDO1A+ and SDO1A- is opened. STO release state (in driving): Between SDO1A+ and SDO1A- is closed.	
B-axis SDO1	SDO1B+ SDO1B-	3A	Outputs STO1 to B-axis driving device.	DO-1
		3B	Outputs the same signal as B-axis SDO2. STO state (base shutdown): Between SDO1B+ and SDO1B- is opened. STO release state (in driving): Between SDO1B+ and SDO1B- is closed.	

APPENDIX

(4) CN10

Device	Symbol	Pin No.	Function/Application	I/O division
A-axis shutdown 2	SDI2A+ SDI2A-	3A 3B	Connect this device to a safety switch for A-axis driving device. Input the same signal as A-axis shutdown 1. STO state (base shutdown): Open between SDI2A+ and SDI2A-. STO release state (in driving): Close between SDI2A+ and SDI2A-.	DI-1
B-axis shutdown 2	SDI2B+ SDI2B-	4A 4B	Connect this device to a safety switch for B-axis driving device. Input the same signal as B-axis shutdown 1. STO state (base shutdown): Open between SDI2B+ and SDI2B-. STO release state (in driving): Close between SDI2B+ and SDI2B-.	DI-1
A-axis EMG start/reset	SRESA+ SRESA-	1A 1B	Signal for releasing STO state (base shutdown) on A-axis driving device. Releases STO state (base shutdown) on A-axis driving device by switching between SRESA+ and SRESA- from on (connected) to off (opened).	DI-1
B-axis EMG start/reset	SRESB+ SRESB-	2A 2B	Signal for releasing STO state (base shutdown) on B-axis driving device. Releases STO state (base shutdown) on B-axis driving device by switching between SRESB+ and SRESB- from on (connected) to off (opened).	DI-1
A-axis SDO2	SDO2A+ SDO2A-	6A 6B	Outputs STO2 to A-axis driving device. Outputs the same signal as A-axis STO1. STO state (base shutdown): Between SDO2A+ and SDO2A- is opened. STO release state (in driving): Between SDO2A+ and SDO2A- is closed.	DO-1
B-axis SDO2	SDO2B+ SDO2B-	5A 5B	Outputs STO2 to B-axis driving device. Outputs the same signal as B-axis SDO1. STO state (base shutdown): Between SDO2B+ and SDO2B- is opened. STO release state (in driving): Between SDO2B+ and SDO2B- is closed.	DO-1
Control circuit power supply	+24 V	7A	Connect + side of 24 V DC.	
Control circuit power GND	0 V	7B	Connect - side of 24 V DC.	
A-axis STO state	TOFA	8A	TOFA is internally connected with TOF2A.	
B-axis STO state	TOFB	8B	TOFB is internally connected with TOF2B.	

App. 5.8.2 Interfaces

In this servo amplifier, source type I/O interfaces can be used.

(1) Sink I/O interface (CN9, CN10 connector)

(a) Digital input interface DI-1

This is an input circuit whose photocoupler cathode side is input terminal.

Transmit signals from sink (open-collector) type transistor output, relay switch, etc.

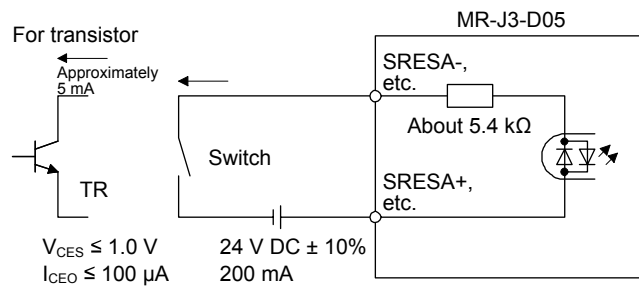

APPENDIX

(b) Digital output interface DO-1

This is a circuit of collector output terminal of the output transistor.

When the output transistor is turned on, collector terminal current will be applied for the output. A lamp, relay or photocoupler can be driven. Install a diode (D) for an inductive load, or install an inrush current suppressing resistor (R) for a lamp load. (Rated current: 40 mA or less, maximum current: 50 mA or less, inrush current: 100 mA or less) A maximum of 2.6 V voltage drop occurs in the MR-J3-D05.

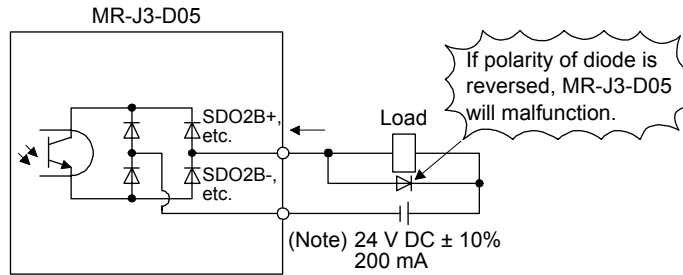

Note. If the voltage drop (maximum of 2.6 V) interferes with the relay operation, apply high voltage (maximum of 26.4 V) from external source.

(2) Source I/O interfaces (CN9, CN10 connector)

(a) Digital input interface DI-1

This is an input circuit whose photocoupler anode side is input terminal.

Transmit signals from source (open-collector) type transistor output, relay switch, etc.

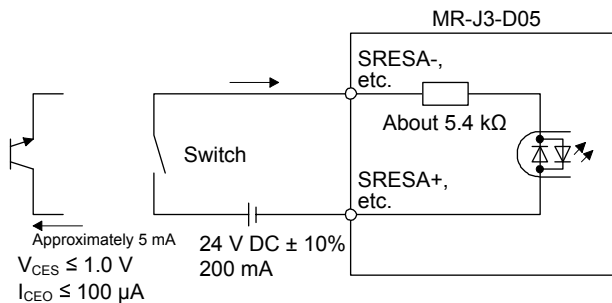

(b) Digital output interface DO-1

This is a circuit of emitter output terminal of the output transistor.

When the output transistor is turned on, current will be applied from the output to a load.

A maximum of 2.6 V voltage drop occurs in the servo amplifier.

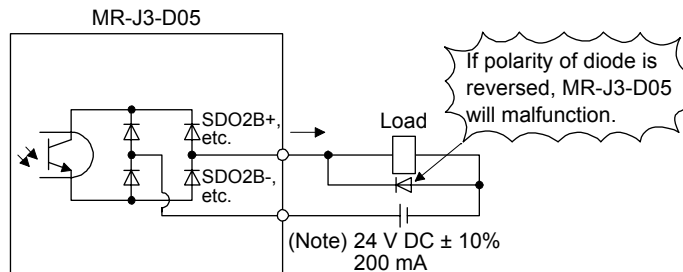

Note. If the voltage drop (maximum of 2.6 V) interferes with the relay operation, apply high voltage (maximum of 26.4 V) from external source.

APPENDIX

App. 5.8.3 Wiring CN9 and CN10 connectors

Handle with the tool with care when connecting wires.

(1) Wire strip

- (a) Use wires with size of AWG 24 to 20 (0.22 mm^2 to 0.5 mm^2) (recommended electric wire: UL1007) and strip the wires to make the stripped length $7.0 \text{ mm} \pm 0.3 \text{ mm}$. Confirm the stripped length with gauge, etc. before using the wires.
- (b) If the stripped wires are bent, feazed or too thick due to twisting too much, fix the wires by twisting lightly, etc. Then, confirm the stripped length before using the wires. Do not use excessively deformed wires.
- (c) Smooth out the wire surface and stripped insulator surface.

(2) Connecting wires

Before connecting wires, be sure to pull out the receptacle assembly from the header connector. If wires are connected with inserted connector, the connector and the printed board may malfunction.

- (a) Using extraction tool (1891348-1 or 2040798-1)

1) Dimensions and mass

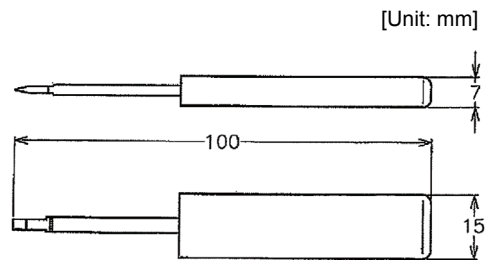

Mass: Approx. 20 g

APPENDIX

2) Connecting wires

- a) Confirm the model number of the housing, contact and tool to be used.
- b) Insert the tool diagonally into the receptacle assembly.

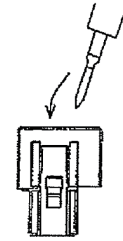

- c) Insert the tool until it hits the surface of the receptacle assembly. At this stage, the tool is vertical to the receptacle assembly.

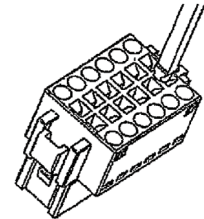

- d) Insert wires in the wiring hole till the end. The wires should be slightly twisted in advance to prevent it from being feazed.

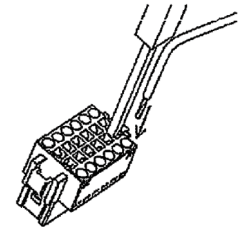

It is easy to insert the wire if the wire is inserted diagonally while twisting the tool.

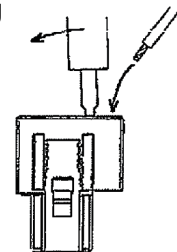

- e) Remove the tool.

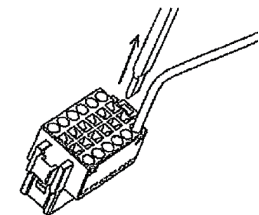

APPENDIX

(b) Using a screwdriver

To avoid damaging housings and springs when wiring with screwdriver, do not put excessive force. Be cautious when connecting.

1) Adjusting screw driver

Diameter: 2.3 mm \pm 0.05 mm
Length: 120 mm or less
Width: 2.3 mm, Blade thickness: 0.25 mm
Angle in tip of the blade: 18 ± 1 degrees

Diameter: 2.5 mm \pm 0.05 mm
Length: 120 mm or less
Width: 2.5 mm, Blade thickness: 0.3 mm
Angle in tip of the blade: 12 ± 1 degrees

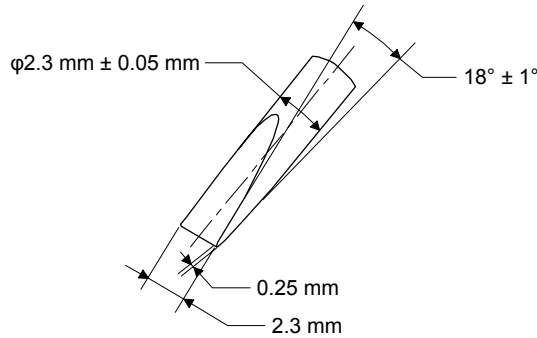

Screwdriver diameter: $\phi 2.3 \text{ mm}$

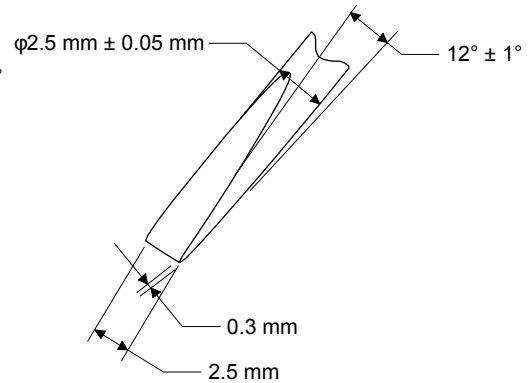

Screwdriver diameter: $\phi 2.5 \text{ mm}$

2) Connecting wires

- a) Insert a screwdriver in the front slot a little diagonally, and depress the spring. While depressing the spring, insert the wires until they hit the end. Note that the housing and spring may be damaged if the screwdriver is inserted strongly. Never insert the screwdriver in the wire hole. Otherwise, the connector will be damaged.
- b) Pull the screwdriver out while pressing the wires. Connecting wires is completed.
- c) Pull the wire lightly to confirm that the wire is surely connected.
- d) To remove the wires, depress the spring by the screwdriver in the same way as connecting wires, and then pull the wires out.

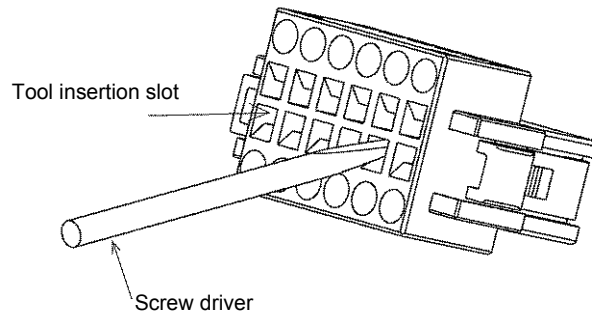

APPENDIX

(3) Connector insertion

Insert the connector all the way straight until you hear or feel clicking. When removing the connector, depress the lock part completely before pulling out. If the connector is pulled out without depressing the lock part completely, the housing, contact and/or wires may be damaged.

(4) Compatible wire

Compatible wire size is listed below.

Wire size	
mm ²	AWG
0.22	24
0.34	22
0.50	20

(5) Others

(a) Fix a wire tie at least distance of "A" × 1.5 away from the end of the connector.

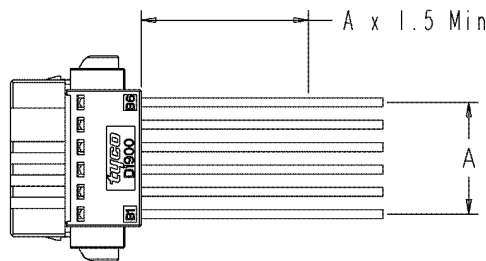

(b) Be sure that wires are not pulled excessively when the connector is inserted.

App. 5.8.4 Wiring FG

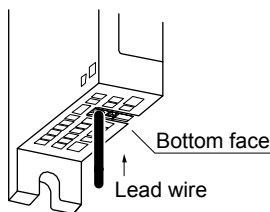

Wire range

Single wire: $\phi 0.4$ mm to 1.2 mm (AWG 26 to AWG 16)

Stranded wire: 0.2 mm² to 1.25 mm² (AWG 24 to AWG 16),
wire $\phi 0.18$ mm or more

APPENDIX

App. 5.9 LED display

I/O status, malfunction and power on/off are displayed with LED for each A-axis and B-axis.

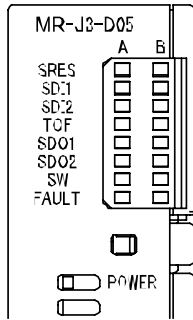

LED	Definition	LED	
		Column A	Column B
SRES	Monitor LED for start/reset Off: The start/reset is off. (The switch contact is opened.) On: The start/reset is on. (The switch contact is closed.)	A-axis	B-axis
SDI1	Monitor LED for shut-off 1 Off: The shut-off 1 is off. (The switch contact is closed.) On: The shut-off 1 is on. (The switch contact is opened.)		
SDI2	Monitor LED for shut-off 2 Off: The shut-off 2 is off. (The switch contact is closed.) On: The shut-off 2 is on. (The switch contact is opened.)		
TOF	Monitor LED for STO state Off: Not in STO state On: In STO state		
SDO1	Monitor LED for SDO1 Off: Not in STO state On: In STO state		
SDO2	Monitor LED for SDO2 Off: Not in STO state On: In STO state		
SW	Monitor LED for confirming shutdown delay setting Off: The settings of SW1 and SW2 do not match. On: The settings of SW1 and SW2 match.		
FAULT	FAULT LED Off: Normal operation (STO monitoring state) On: Fault has occurred.		
POWER	Power supply Off: Power is not supplied to MR-J3-D05. On: Power is being supplied to MR-J3-D05.	/	

App. 5.10 Rotary switch setting

Rotary switch is used to shut off the power after control stop by SS1 function.

Set the delay time for STO output after STO shut off switch is pressed. Set same setting for SW1 and SW2, and set the rotary switch setting according to the delay time in the table below.

Setting cannot be changed while power is on. Notify users that setting cannot be changed by putting a seal or by another method so that end users will not change the setting after the shipment.

0 to F in the following table is the set value of the rotary switches (SW1 and SW2).

Rotary switch setting and delay time at A/B-axis [s]

		B-axis					
		0 s	1.4 s	2.8 s	5.6 s	9.8 s	30.8 s
A-axis	0 s	0	1	2	-	3	4
	1.4 s		-	5	-	6	7
	2.8 s			8	-	9	A
	5.6 s				-	B	C
	9.8 s					D	E
	30.8 s						F

APPENDIX

App. 5.11 Troubleshooting

When power is not supplied or FAULT LED turns on, refer the following table and take the appropriate action.

Event	Definition	Cause	Action
Power is not supplied.	Power LED does not turn on although power is supplied.	1. 24 V DC power supply is malfunctioning.	Replace the 24 V DC power supply.
		2. Wires between MR-J3-D05 and 24 V DC power supply are disconnected or are in contact with other wires.	Check the wiring.
		3. MR-J3-D05 is malfunctioning.	Replace the MR-J3-D05.
FAULT LED is on.	FAULT LED of A-axis or B-axis is on, and will not turn off.	1. The delay time settings are not matched.	Check the settings of the rotary switch.
		2. Switch input error	Check the wiring or sequence of the input signals.
		3. TOF signal error	Check the connection with the servo amplifier.
		4. MR-J3-D05 is malfunctioning.	Replace the MR-J3-D05.

APPENDIX

App. 5.12 Dimensions

[Unit: mm]

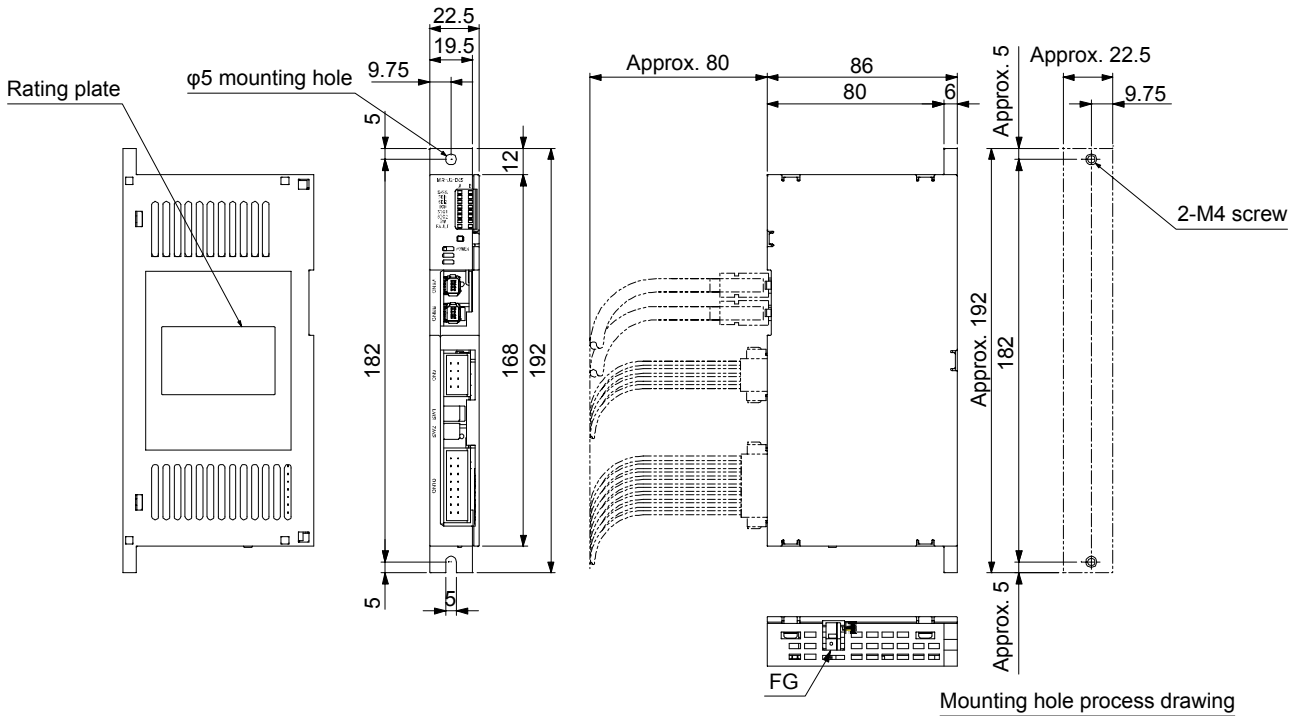

Assignment

CN8A		CN8B	
7	8	7	8
TOF2A	TOF1A	TOF2B	TOF1B
5	6	5	6
STO2A-	STO2A+	STO2B-	STO2B+
3	4	3	4
	STO1A+		STO1B+
1	2	1	2
STO1A-		STO1B-	

CN9		CN10	
1A	1B	1A	1B
SDI1A+	SDI1A-	SRESA+	SRESA-
2A	2B	2A	2B
SDI1B+	SDI1B-	SRESB+	SRESB-
3A	3B	3A	3B
SDO1B+	SDO1B-	SDI2A+	SDI2A-
4A	4B	4A	4B
SDO1A+	SDO1A-	SDI2B+	SDI2B-
		5A	5B
		SDO2B+	SDO2B-
		6A	6B
		SDO2A+	SDO2A-
		7A	7B
		+24 V	0 V
		8A	8B
		TOFA	TOFB

Mounting screw

Screw size: M4

Tightening torque: 1.2 N•m

Mass: 0.2 [kg]

APPENDIX

App. 5.13 Installation

Follow the instructions in this section and install MR-J3-D05 in the specified direction. Leave clearances between MR-J3-D05 and other equipment including the cabinet.

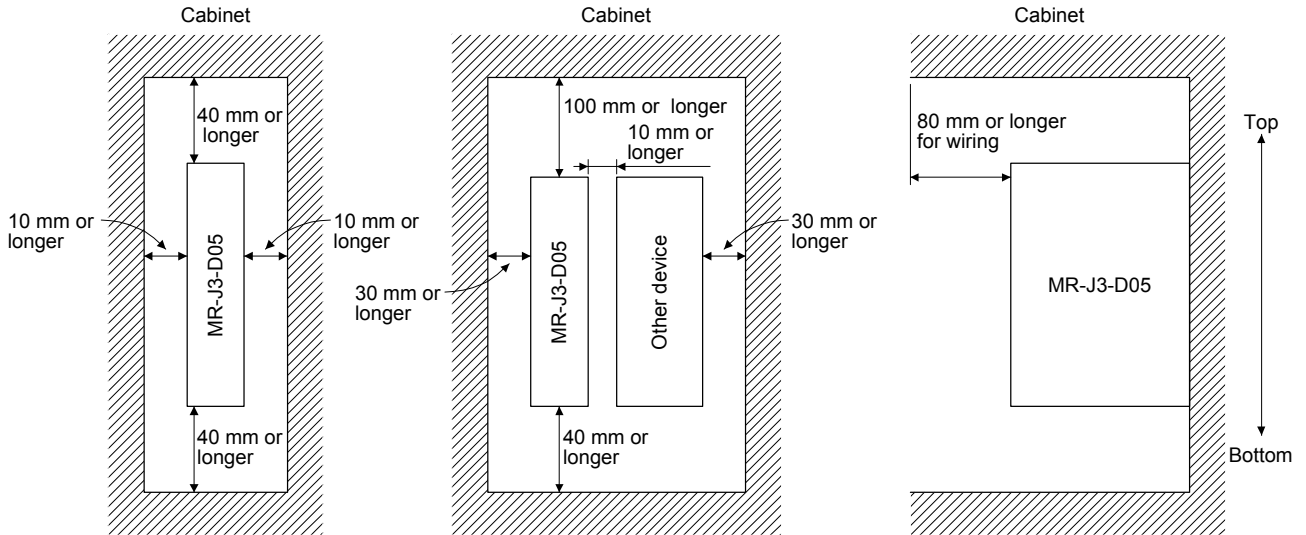

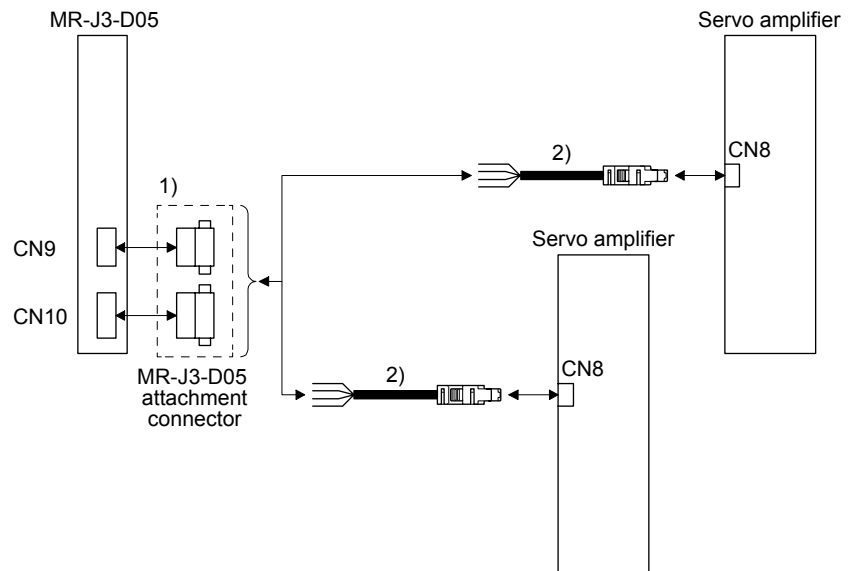

App. 5.14 Combinations of cable/connector

POINT
● MR-D05UDL_M (STO cable) for MR-J3 series cannot be used.



APPENDIX

No.	Name	Model	Description
1)	Connector	MR-J3-D05 attachment connector	<div style="display: flex; justify-content: space-around; align-items: center;"> <div style="text-align: center;">  <p>Connector for CN9: 1-1871940-4 (TE Connectivity)</p> </div> <div style="text-align: center;">  <p>Connector for CN10: 1-1871940-8 (TE Connectivity)</p> </div> </div>
2)	STO cable	MR-D05UDL3M-B Cable length: 3 m	<p>Connector set: 2069250-1 (TE Connectivity)</p> <div style="text-align: center;">  </div>

COMPLIANCE WITH THE MACHINERY DIRECTIVES

The MR-J3-D05 complies with the safety components laid down in the directive 2006/42/EC (Machinery).

App. 6 EC declaration of conformity

The MR-J4 series servo amplifiers and MR-J3-D05 safety logic unit complies with the safety component laid down in the Machinery directive.



ZERTIFIKAT

CERTIFICATE

EC Type-Examination Certificate

Reg.-No.: 01/205/5196/12

Product tested	AC Servo Drive with integrated safety function "Safe Torque Off (STO)"	Certificate holder	Mitsubishi Electric Corporation Nagoya Works 1-14 Yada-Minami 5-chome Higashi-ku Nagoya 461-8670 Japan
Type designation	MR-J4-*A* MR-J4-*B* MR-J4W2-*B* MR-J4W3-*B*	Manufacturer	see certificate holder
Codes and standards forming the basis of testing	EN 61800-5-2:2007 EN 61800-5-1:2007 (in extracts) EN 61800-3:2004 EN ISO 13849-1:2008 + AC:2009		EN 62061:2005 + AC:2010 EN 60204-1:2006 + A1:2009 + AC:2010 (in extracts) IEC 61508 Parts 1-7:2010
Intended application	The safety function "Safe Torque Off" complies with the requirements of the relevant standards (PL d acc. to EN ISO 13849-1, SIL CL 2 acc. to EN 61800-5-2/ EN 62061/ IEC 61508) and can be used in applications up to PL d acc. to EN ISO 13849-1 and SIL 2 acc. to EN 62061/ IEC 61508.		
Specific requirements	The instructions of the associated Installation and Operating Manual shall be considered.		
It is confirmed, that the product under test complies with the requirements for machines defined in Annex I of the EC Directive 2006/42/EC.			
This certificate is valid until 2017-02-28.			



The test report-no.: 968/M 342.00/12 dated 2012-02-28 is an integral part of this certificate.

The holder of a valid licence certificate for the product tested is authorized to affix the test mark shown opposite to products, which are identical with the product tested.





Berlin, 2012-02-28

Certification Body for Machinery, NB 0035

Dipl.-Ing. Eberhard Frejno



ZERTIFIKAT
CERTIFICATE

Nr./No. 968/EL 612.00/09

Prüfgegenstand Product tested	Safety Logic Module for usage in combination with MR-J3-□S Servo Drives	Inhaber Holder	Mitsubishi Electric Corporation Nagoya Works 1-14 Yada-Minami 5-chome, Higashi-ku Nagoya 461-8670 Japan
Typbezeichnung Type designation	MR-J3-D05	Verwendungszweck Intended application	Drive Applications STO / SS1 acc. to EN 61800-5-2 Safe Stop / Safe Off Stop Category 0 / Stop Category 1 acc. to EN 60204-1
Prüfgrundlagen Codes and standards forming the basis of testing	EN ISO 13849-1:2008 EN 62061:2005 EN 61800-5-2:2007 EN 61800-5-1:2007	EN 61800-3:2004 EN 60204-1:2006 EN 50178:1997 EN 61508-1 to -7:2000-2002	
Prüfungsergebnis Test results	The MR-J3-D05 Safety Logic Module in combination with the MR-J3 series servo drives is suitable for the basic safety functions "STO" and "SS1" (Type C) according to EN 61800-5-2 as well as "Safe Stop" (Stop category 0 and Stop category 1) and "Safe Off" according to EN 60204-1. It can be used within safety related applications up to Safety Category 3 / PL d and SIL 2 / SIL CL 2 according to EN ISO 13849-1 and EN 62061.		
Besondere Bedingungen Specific requirements	For a safe usage of the product the instructions in the user documentation must be observed. For "Safe Off" two suitable additional magnetic contactors must be used additionally.		

Der Prüfbericht-Nr.: 968/EL 612.00/09 vom 21.04.2009 ist Bestandteil dieses Zertifikates.
Dieses Zertifikat ist nur gültig für Erzeugnisse, die mit dem Prüfgegenstand übereinstimmen. Es wird ungültig bei jeglicher Änderung der Prüfgrundlagen für den angegebenen Verwendungszweck.

The test report-no.: 968/EL 612.00/09 dated 2009-04-21 is an integral part of this certificate.
This certificate is valid only for products which are identical with the product tested. It becomes invalid at any change of the codes and standards forming the basis of testing for the intended application.

TÜV Rheinland Industrie Service GmbH
Geschäftsfeld ASI
Automation, Software und Informationstechnologie
Am Grauen Stein, 51105 Köln
Postfach 91 09 51, 51101 Köln

2009-04-21
Datum/Date

Firmenstempel/Company stamp

Dipl.-Ing. Heinz Gall

App. 7 How to replace servo amplifier without magnetic pole detection



CAUTION

- Be sure to write the magnetic pole information of the servo amplifier before the replacement to the servo amplifier after the replacement. If the information before and after replacement are not the same, the servo motor may operate unexpectedly.

When replacing the servo amplifier, carry out the magnetic pole detection again. If the magnetic pole detection cannot be performed unavoidably, write the magnetic pole information from the servo amplifier before the replacement to the one after the replacement using MR Configurator2.

(1) Procedures

- Read the magnetic pole information of the servo amplifier before the replacement.
- Write the read magnetic pole information to the servo amplifier after the replacement.
- Perform the test operation with the torque limit for ensuring the safety, and confirm that there is no trouble.

(2) Migration method of the magnetic pole information

(a) How to read the magnetic pole information from the servo amplifier before the replacement

- Open the project in MR Configurator2, select "MR-J4-B" for model, and select "Linear" for operation mode. Tick the "Multi axis" box and select one from A-axis to C-axis from the menu.
- Check that the personal computer is connected with the servo amplifier, and select "Diagnosis" and then "Linear diagnosis".
- Click the "Magnetic pole information" button (1) in figure) to open the magnetic pole information window.
- Click "Read All" of the magnetic pole information window. (2) in figure)
- Confirm the data 1 and data 2 (3) in figure) of the magnetic pole information window and take notes.

(b) How to write the magnetic pole information to the servo amplifier after the replacement

- Open the project in MR Configurator2, select "MR-J4-B" for model, and select "Linear" for operation mode. Tick the "Multi axis" box and select one from A-axis to C-axis from the menu.
- Check that the personal computer is connected with the servo amplifier, and select "Diagnosis" and then "Linear diagnosis".
- Click the "Magnetic pole information" button (1) in Figure) to open the magnetic pole information window.
- Input the value of the magnetic pole information taken notes to the data 1 and data 2 (3) in figure) of the magnetic pole information window.
- Click "Write All" (4) in figure) of the magnetic pole information window.

APPENDIX

App. 8.2 Connector set

Connector set	1) Servo amplifier-side connector	2) Servo motor-side connector
MR-ECNM	Receptacle: 36210-0100PL Shell kit: 36310-3200-008 (3M)	Connector set: 54599-1019 (Molex)
	<p>View seen from wiring side. (Note)</p>	Housing: 1-172161-9 Connector pin: 170359-1 (TE Connectivity or equivalent) Cable clamp: MTI-0002 (Toa Electric Industry)
	<p>Note. Keep open the pins shown with . Especially, pin 10 is provided for manufacturer adjustment. If it is connected with any other pin, the servo amplifier cannot operate normally.</p>	<p>View seen from wiring side.</p>

App. 8.3 Internal wiring diagram

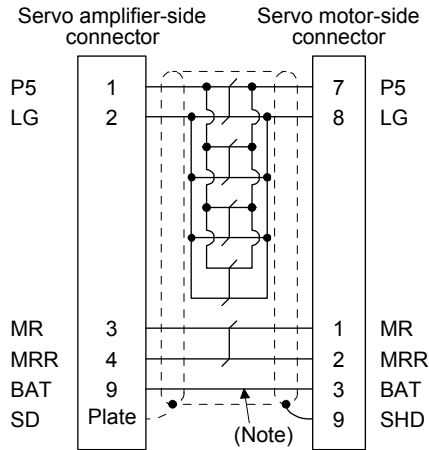

Note. Always make connection for use in an absolute position detection system. Wiring is not necessary for use in an incremental system.

APPENDIX

App. 9 SSCNET III cable (SC-J3BUS_M-C) manufactured by Mitsubishi Electric System & Service



POINT
<ul style="list-style-type: none"> ● For the details of the SSCNET III cables, contact your local sales office. ● Do not look directly at the light generated from CN1A/CN1B connector of servo amplifier or the end of SSCNET III cable. The light can be a discomfort when it enters the eye.

The cable is available per 1 m up to 100 m. The number of the length (1 to 100) will be in the underscore in the cable model.

Cable model	Cable length	Bending life	Application/remark
	1 m to 100 m		
SC-J3BUS_M-C	1 to 100	Ultra-long bending life	Using long distance cable

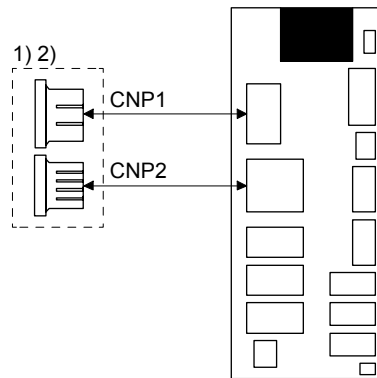
App. 10 CNP_crimping connector



No.	Name	Model	Definition	Number of parts
1)	Connector set	MR-J3WCNP12-DM	  For CNP1 Receptacle housing: J43FSS-03V-KX Receptacle contact: BJ4F-71GF-M3.0 (JST) Applicable wire Wire size: 1.25 mm ² to 2.0 mm ² (AWG 16 to 14) Insulator OD: 2.0 mm to 3.8 mm The crimping tool (YRF-1130) is required.	1 each
2)	Connector set	MR-J3WCNP12-DM-10P	For CNP2 Receptacle housing: F32FMS-06V-KXY Receptacle contact: BF3F-71GF-P2.0 (JST) Applicable wire Wire size: 1.25 mm ² to 2.0 mm ² (AWG 16 to 14) Insulator OD: 2.4 mm to 3.4 mm The crimping tool (YRF-1070) is required.	10 each

APPENDIX

App. 11 Recommended cable for servo amplifier power supply

The following information is as of February 2013. For the latest information, contact the manufacturer.

Manufacturer: Mitsubishi Electric System & Service

<Sales office> FA PRODUCT DIVISION mail: oss-ip@melsc.jp

(1) Specifications

1 Primary-side power cable

Name	Model	Wire size	Insulator material	Minimum bend radius [mm]	Insulator OD [mm]	Applicable standard (wire part)
1) Main circuit power supply	SC-EMP01CBL_M-L	AWG 14 × 3 pcs.	PVC (red, white, blue)	30	Approx. 3.6	UL 1063/MTW
2) Control circuit power supply	SC-ECP01CBL_M-L	AWG 16 × 2 pcs.	PVC (red, white)	30	Approx. 3.2	
3) Regenerative option	SC-ERG01CBL_M-L	AWG 14 × 2 pcs.	PVC (black)	30	Approx. 3.6	
4) Built-in regenerative resistor short circuit connector	SC-ERG02CBL01M-L	AWG 14 × 1 pcs.		-		

A symbol "_" in the model name indicates a cable length.

Motor-side power cable

Name	Model	Wire size	Material		Minimum bend radius [mm]	Overall diameter [mm]	Applicable standard (wire part)
			Insulator	Outer sheath			
5) Direct connection to rotary servo (up to 10 m)	Standard SC-EPWS1CBL_M-*-L	AWG18 × 4C	ETFE		50	Approx. 6.2	UL 13/CL3
6) Long bending life	SC-EPWS1CBL_M-*-H	AWG19 × 4C			40	Approx. 5.7	UL AWM 2103
7) Linear servo (up to 10 m)	Standard SC-EPWS2CBL_M-L	AWG18 × 4C	PVC	PVBC (black)	50	Approx. 6.2	UL 13/CL3
8) Linear servo (more than 10 m)/junction connection to rotary servo (more than 10 m)		AWG16 × 4C			90	Approx. 11.1	UL AWM 2501
9) Linear servo (up to 10 m)	Long bending life SC-EPWS2CBL_M-H	AWG19 × 4C	ETFE		40	Approx. 5.7	UL AWM 2103
10) Linear servo (more than 10 m)/junction connection to rotary servo (more than 10 m)		AWG14 × 4C			75	Approx. 10.5	UL AWM 2501

A symbol "_" in the model name indicates a cable length.

A symbol "*" in the model name is "A1" or "A2". A1: Load-side lead, A2: Opposite to load-side lead.

The characters "-H" or "-L" at the end of a model name indicate a bending life. A model name with the characters "-H" has a long bending life, and "-L" has a standard bending life.

APPENDIX

(2) Dimensions

[Unit: mm]

1) [SC-EMP01CBL_M-L]

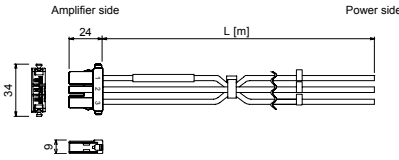

2) [SC-ECP01CBL_M-L]

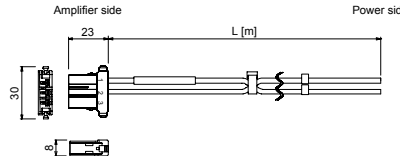

3) [SC-ERG01CBL_M-L]

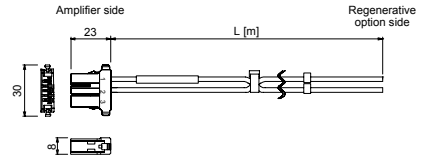

4) [SC-ERG02CBL01M-L]

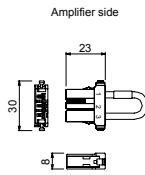

5)/6) [SC-EPWS1CBL_M-*-L/
SC-EPWS1CBL_M-*-H]

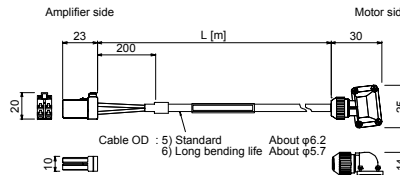

7)/8)/9)/10) [SC-EPWS2CBL_M-L/
SC-EPWS2CBL_M-H]

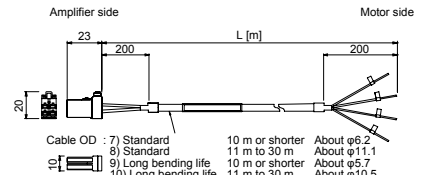

A symbol "_" in the model name indicates a cable length.

A symbol "*" in the model name is "A1" or "A2". A1: Load-side lead, A2: Opposite to load-side lead.

App. 12 J3 compatibility mode

POINT
<ul style="list-style-type: none"> The fully closed loop control in the J3 compatibility mode is supported by the servo amplifiers of which software version is A3 or above.

App. 12.1 Outline of J3 compatibility mode

MR-J4W-_B servo amplifiers and MR-J4-_B servo amplifiers have two operation modes. "J4 mode" is for using all functions with full performance and "J3 compatibility mode" is compatible with MR-J3-B series for using the amplifiers as the conventional series.

When you connect an amplifier with SSCNET III/H communication for the first controller communication by factory setting, the operation mode will be fixed to "J4 mode". For SSCNET communication, it will be fixed to "J3 compatibility mode". When you set the mode back to the factory setting, use the application "MR-J4(W)-B mode selection".

The application "MR-J4(W)-B mode selection" is packed with MR Configurator2 of software version 1.12N or later.

For the operating conditions of the application "MR-J4(W)-B mode selection", use MR Configurator2. (Refer to section 11.4.)

APPENDIX

App. 12.2 Operation modes supported by J3 compatibility mode

The J3 compatibility mode supports the following operation modes.

Operation mode in J3 compatibility mode	Model of MR-J3-_B	Model of MR-J3-_S	Model of MR-J3W-_B
MR-J3B standard control mode (rotary servo motor)	MR-J3-_B	MR-J3-_S	MR-J3W-_B
MR-J3-B fully closed loop control mode	MR-J3-_B-RJ006	MR-J3-_S	
MR-J3-B linear control mode	MR-J3-_B-RJ004		MR-J3W-_B
MR-J3-B DD motor control mode	MR-J3-_B-RJ080W		MR-J3W-_B

Each operation mode has the same ordering as conventional MR-J3-B series servo amplifiers and is compatible with their settings. Therefore, new functions added for MR-J4W-_B and MR-J4-_B servo amplifiers cannot be used.

In addition, the control response characteristic in the J3 compatibility mode will be the same as that of MR-J3 series. When you need a higher response, using the J4 mode is recommended.

App. 12.3 J3 compatibility mode supported function list

Function	Name	Corresponding (□: J4 new, ○: Equivalent to J3, ×: Not available)		
		MR-J4/J4W series		MR-J3 series (Note 8)
		J4 mode	J3 compatibility mode	
Basic specification	Speed frequency response	2.5 kHz	2.1 kHz	2.1 kHz
	Encoder resolution	22 bit (Note 1)	18 bit (Note 1)	18 bit
SSCNET III/H communication or SSCNET III communication	Communication baud rate	150 Mbps	50 Mbps	50 Mbps
	Maximum distance between stations	100 m	50 m	50 m
Basic function	Absolute position detection system	○	○	○
	Fully closed loop control (Note 9)	○ (Two-wire type only)	○ (Two-wire type only)	MR-J3-_B-RJ006 MR-J3-_S
	Linear servo motor driving	○	○	MR-J3-_B-RJ004 MR-J3W-_B
	Direct drive motor driving	○	○	MR-J3-_B-RJ080W MR-J3W-_B
	Motor-less operation	○ (Note 2)	○ (Note 2)	○
Encoder output pulses	Rotation direction selection/travel direction selection	○	○	○
	A/B-phase pulse output	○ (Note 3)	○ (Note 3)	○
Input/output	Z-phase pulse output	○ (Note 4)	○ (Note 4)	○ (Note 4)
	Analog monitor output	○ (Note 5)	○ (Note 5)	○
	Motor thermistor	○	○	MR-J3-_B-RJ004 MR-J3-_B-RJ080W MR-J3W-_B
Control mode	Position control mode	○	○	○
	Speed control mode	○	○	○
	Torque control mode	○	○	○
	Continuous operation to torque control mode	○	○	○
Auto tuning	Auto tuning mode 1	○	○	○
	Auto tuning mode 2	○	○	○
	2 gain adjustment mode 1 (interpolation mode)	○	○	○
	2 gain adjustment mode 2	□	×	×
	Manual mode	○	○	○

APPENDIX

Function	Name	Corresponding (□: J4 new, ○: Equivalent to J3, ×: Not available)		
		MR-J4/J4W series		MR-J3 series (Note 8)
		J4 mode	J3 compatibility mode	
Filter function	Machine resonance suppression filter 1	○	○	○
	Machine resonance suppression filter 2	○	○	○
	Machine resonance suppression filter 3	□	×	×
	Machine resonance suppression filter 4	□	×	×
	Machine resonance suppression filter 5	□	×	×
	Shaft resonance suppression filter	○	×	×
	Low-pass filter	○	○	○
	Robust disturbance compensation (Note 10)	×	○	○
	Robust filter	□	×	×
Vibration suppression control	Standard mode/3 inertia mode	□	×	×
	Vibration suppression control 1	○	○	○
	Vibration suppression control 2	□	×	×
	Command notch filter	○	○	○
Applied control	Gain switching	○	○	○
	Slight vibration suppression control	○	○	○
	Overshoot amount compensation	○	○	○
	PI-PID switching control	○	○	○
	Feed forward	○	○	○
	Torque limit	○	○	○
	Master-slave operation function	×	×	○
Adjustment function	One-touch tuning	□	×	×
	Adaptive tuning	○	○	○
	Vibration suppression control 1 tuning	○	○	○
	Vibration suppression control 2 tuning	□	×	×
Fully closed loop control	Fully closed loop electronic gear	○	○	MR-J3-_B MR-J3-_B-RJ006
	Dual feedback control	○	○	
	Semi closed/fully closed switching loop control	○	○	
	Fully closed loop control error detection function	○	○	
Linear control	Linear servo control error detection function	○	○	MR-J3-_B-RJ004 MR-J3W-_B
	Servo motor series/types setting function	○	○	
Magnetic pole detection	Direct current exciting method magnetic pole detection	○	○	MR-J3-_B-RJ004 MR-J3-_B-RJ080W MR-J3W-_B
	Current detection method magnetic pole detection	×	○	MR-J3-_B-RJ004 MR-J3W-_B
	Minute position detection method magnetic pole detection	○	○	MR-J3-_B-RJ004 MR-J3-_B-RJ080W
	Initial magnetic pole detection error detection function	○	○	MR-J3W-_B

APPENDIX

Function	Name	Corresponding (□: J4 new, ○: Equivalent to J3, ×: Not available)		
		MR-J4/J4W series		MR-J3 series (Note 8)
		J4 mode	J3 compatibility mode	
Encoder	Semi closed loop control two-wire type/four-wire type selection	○	○	○
	Serial interface compatible linear encoder	○	○	MR-J3-_S MR-J3-_B-RJ006 MR-J3-_B-RJ004 MR-J3W-_B
	Pulse train interface (ABZ-phase output type) compatible linear encoder	×	×	MR-J3-_S MR-J3-_B-RJ006 MR-J3-_B-RJ004
Safety function	STO function	○	○	MR-J3-_S
	Forced stop deceleration function at alarm occurrence	○	○ (Note 12)	MR-J3-_S
	Vertical axis freefall prevention function	○	○	MR-J3-_S
Tough drive function	Vibration tough drive	□	×	×
	Instantaneous power failure tough drive	□	×	×
Diagnosis function	3-digit alarm display	□	□	MR-J3W-_B
	16 alarm histories supported	□	× (Note 7)	× (Note 7)
	Drive recorder function	□	×	×
	Machine diagnosis function	□	×	×
Controller	SSCNET III	×	○	○
	SSCNET III/H	□	×	×
	Home position return function	○	○	○
Others	J4/J3 compatibility mode automatic identification (Note 11)	○	○	×
	Power monitoring function	□	×	×

- Note
1. The value is at the HG series servo motor driving.
 2. The motor-less operation for the linear servo motor and direct drive motor driving will be available in the future.
 3. It is not available with the MR-J4W3-_B servo amplifiers.
 4. It is not available with the MR-J3W-_B, MR-J4W2-_B, and MR-J4W3-_B servo amplifiers.
 5. It is not available with the MR-J4W2-_B and MR-J4W3-_B servo amplifiers.
 6. The minute position detection method is available instead.
 7. Alarm history will be saved up to five times.
 8. The functions of the product with modified parts (GA) in the MR-J3-_B servo amplifiers are all covered by the J3 compatibility mode of the MR-J4-_B servo amplifiers.
 9. MR-J4W3-_B servo amplifiers do not support the fully closed loop control system.
 10. For MR-J4 series, the robust filter and vibration tough drive are available instead.
 11. The operation mode will be adjusted automatically at the first controller communication. You can change the operation mode with the application "MR-J4(W)-B mode selection".
 12. When MR-J4 is used as a replacement of MR-J3-_S, "Servo forced stop selection" in [Pr. PA04] will be "Disabled (_ 1 _)" in the initial setting. Change the setting as required.

APPENDIX

App. 12.4 How to switch J4/J3 compatibility mode

There are two ways to switch the J4/J3 compatibility mode with the MR-J4W_ _B servo amplifier and MR-J4_ _B servo amplifier.

(1) Mode selection by the automatic identification of the servo amplifier

J4/J3 compatibility mode is identified automatically depending on the connected controller.

When the controller make a connection request with SSCNET III/H communication, the mode will be "J4 mode". For SSCNET communication, it will be "J3 compatibility mode".

For the J3 compatibility mode, standard control, linear servo motor control, or direct drive motor control will be identified automatically with a motor (encoder) connected to the servo amplifier. For the J4 mode, the operation mode will be the setting of [Pr. PA01].

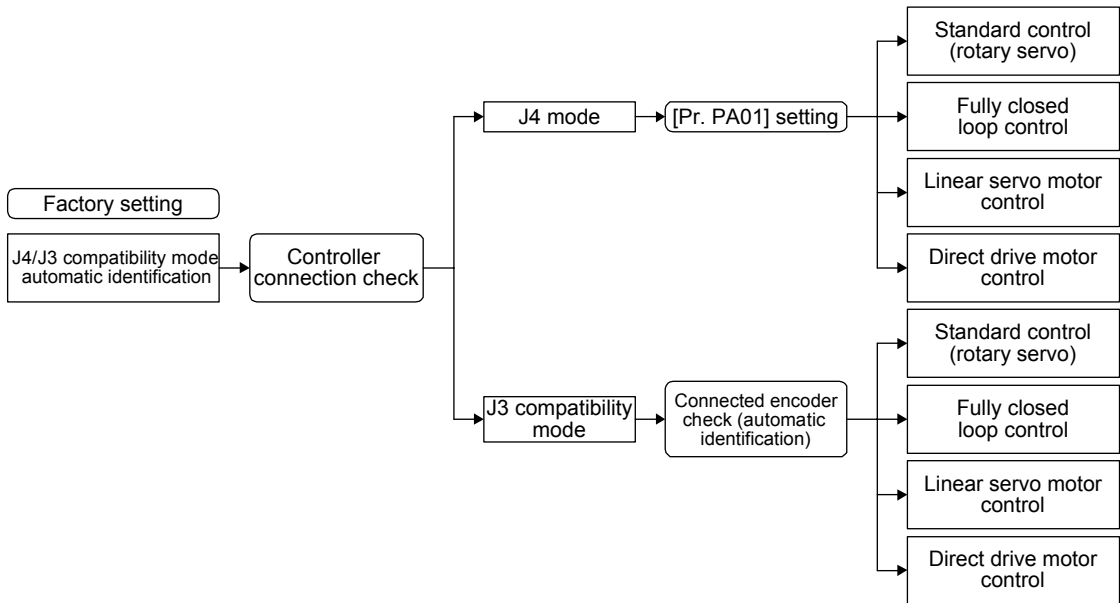

APPENDIX

(2) Mode selection by the automatic identification of the servo amplifier

You can set the factory setting, J4/J3 compatibility mode, and operation mode with the dedicated application.

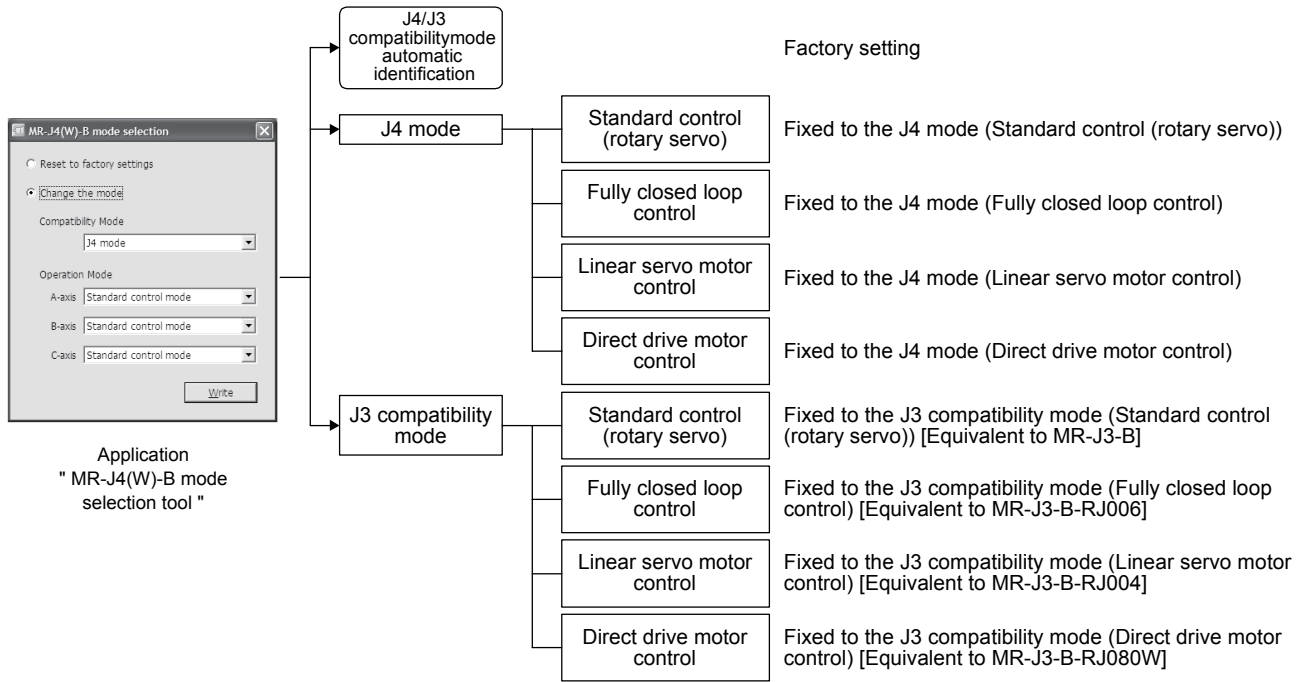

App. 12.5 How to use the J3 compatibility mode

(1) Setting of the controller

To use in the J3 compatibility mode, select MR-J3 series in the system setting window.

Operation mode in J3 compatibility mode	System setting
MR-J3B standard control mode (rotary servo motor)	Select MR-J3- <u>B</u> .
MR-J3-B fully closed loop control mode	Select MR-J3- <u>B</u> fully closed.
MR-J3-B linear control mode	Select MR-J3- <u>B</u> linear.
MR-J3-B DD motor control mode	Select MR-J3- <u>B</u> DDM.

(2) Setting of MR Configurator

To use in the J3 compatibility mode, make the system setting as follows.

Operation mode in J3 compatibility mode	System setting
MR-J3B standard control mode (rotary servo motor)	Select MR-J3- <u>B</u> .
MR-J3-B fully closed loop control mode	Select MR-J3- <u>B</u> fully closed.
MR-J3-B linear control mode	Select MR-J3- <u>B</u> linear.
MR-J3-B DD motor control mode	Select MR-J3- <u>B</u> DDM.

Cautions for using MR Configurator

- The gain search cannot be used. You can use the advanced gain search.
- The C-axis cannot be set for MR-J4W3-B. Use MR Configurator2 for it.

APPENDIX

(3) Setting of MR Configurator2

To use in the J3 compatibility mode, make the system setting as follows.

Operation mode in J3 compatibility mode	System setting
MR-J3B standard control mode (rotary servo motor)	Select MR-J3-_B.
MR-J3-B fully closed loop control mode	Select MR-J3-_B fully closed.
MR-J3-B linear control mode	Select MR-J3-_B linear.
MR-J3-B DD motor control mode	Select MR-J3-_B DDM.

Cautions for using MR Configurator2

- Use MR Configurator2 with software version 1.12N or later. Older version than 1.12N cannot be used.
- Information about existing models (MR-J3) cannot be updated with the parameter setting range update function. Register a new model to use.
- The alarm will be displayed by 3 digits.
- The robust disturbance compensation cannot be used.

App. 12.6 Cautions for switching J4/J3 compatibility mode

The J3 compatibility mode of the operation mode is automatically identified by factory setting depending on a connected encoder. If a proper encoder is not connected at the first connection, the system will not start normally due to a mismatch with a set mode with the controller. (For the J4 mode, you can set the operation mode with [Pr. PA01].) For example, if the controller is connected without connecting a linear encoder at linear servo motor driving, the servo amplifier will be the standard control mode (rotary servo motor). The system will not start because the controller is connected with the linear servo motor driving amplifier. When the operation mode mismatches, the servo amplifier will display [AL. 3E.1 Operation mode error]. Set the mode back to the factory setting or set correctly (J4/J3 compatibility mode and operation mode) using the application "MR-J4(W)-B mode selection".

App. 12.7 Cautions for the J3 compatibility mode

The J3 compatibility mode are partly changed and has restrictions compared with MR-J3 series.

- (1) The alarm display was changed from 2 digits (_ _) to 3 digits (_ _ _). The alarm detail number (_) is displayed in addition to the alarm No (_ _). The alarm No. (_ _) is not changed.
- (2) When the power of the servo amplifier is cut or fiber-optic cable is disconnected, the same type communication can be cut regardless of connection order. When you power on/off the servo amplifier during operation, use the connect/disconnect function of the controller. Refer to the following manuals for detail.
 - Motion controller Q series Programming Manual (COMMON) (Q173D(S)CPU/Q172D(S)CPU) (IB-0300134) "4.11.1 Connect/disconnect function of SSCNET communication"
 - MELSEC-Q QD77MS Simple Motion Module User's Manual (IB-0300185) "14.12 Connect/disconnect function of SSCNET communication"
 - MELSEC-L LD77MH Simple Motion Module User's Manual (IB-0300172) "14.13 Connect/disconnect function of SSCNET communication"
- (3) The J3 compatibility mode has a functional compatibility. However, the operation timing may differ. Check the operation timing on customer side to use.
- (4) The J3 compatibility mode is not compatible with high-response control set by [Pr. PA01 Operation mode].

APPENDIX

- (5) Set the two-wire/four-wire type of the linear encoder in the J3 compatibility mode with [Pr. PC26], not with [Pr. PC04].

App. 12.8 Change of specifications of "J3 compatibility mode" switching process

App. 12.8.1 Detailed explanation of "J3 compatibility mode" switching

- (1) Operation when using a servo amplifier before change of specifications

For the controllers in which "Not required" is described to controller reset in table app. 1, the mode will be switched to "J3 compatibility mode" for all axes at the first connection. However, it takes about 10 s per axis for completing the connection.

For the controllers in which "Reset required" is described in table app. 1, the operation at the first connection is shown in table app. 2. The LED displays will be "Ab." for all axes at the first connection to the controller as shown in table app. 2. After that, resetting controller will change the 1-axis to "b01". The 2-axis and later will not change from "Ab.". After that, one axis will be connected per two times of controller reset.

Table app. 1 Controller reset required/not required list (before change of specifications)

Controller	Model	Controller reset required/not required	
		Single-axis connection	Multi-axis connection
Motion controller	Q17_DSCPU	Not required	Not required
	Q17_DCPU	Not required	Not required
	Q17_HCPU	Not required	Not required
	Q170MCPUCPU	Not required	Not required
Simple motion module Positioning module	QD77MS_	Not required	Not required
	QD75MH_	Not required	Not required
	QD74MH_	Reset required	Reset required
	LD77MH_	Not required	Not required
	FX3U-20SSC-H	Not required	Reset required

Table app. 2 Controller connection operation before change of specifications

	Before change of specifications (software version A4 or below)
First connection of controller	<p>"Ab." is displayed and stops.</p>
After controller reset	<p>"b01" is displayed on axis No. 1, "Ab." is displayed on axis No. 2 and later.</p> <p>One axis is connected per reset.</p>

APPENDIX

(2) Operation when using a servo amplifier after change of specifications

For the controllers in which "Not required" is described to controller reset in table app. 3, the mode will be switched to "J3 compatibility mode" for all axes at the first connection. It takes about 10 s for completing the connection not depending on the number of axes.

For the controllers in which "Reset required" is described in table app. 3, the operation at the first connection is shown in table app. 4. The servo amplifier's mode will be "J3 compatibility mode" and the LED displays will be "rST" for all axes at the first connection to the controller as shown in table app. 4. At the status, resetting controller once will change the display to "b##" (## means axis No.) for all axes and all axes will be ready to connect.

(One controller reset enables to all-axis connection.)

Table app. 3 Controller reset required/not required list
(after change of specifications)

Controller	Model	Controller reset required/not required	
		Single-axis connection	Multi-axis connection
Motion controller	Q17_DSCPU	Not required	Not required
	Q17_DCPU	Not required	Not required
	Q17_HCPU	Not required	Not required
	Q170MCP	Not required	Not required
Simple motion module Positioning module	QD77MS_	Not required	Not required
	QD75MH_	Not required	Not required
	QD74MH_	Reset required	Reset required
	LD77MH_	Not required	Not required
	FX3U-20SSC-H	Reset required	Reset required

Table app. 4 Controller connection operation after change of specifications

	After change of specifications (software version A4 or above)
First connection of controller	
After controller reset	

(3) Using servo amplifiers before and after change of specifications simultaneously

When using servo amplifiers before change of specifications and after change of specifications simultaneously, controller reset is necessary for number of connecting axes of servo amplifiers.

APPENDIX

App. 12.8.2 Changing the mode to "J3 compatibility mode" by using the application "MR-J4(W)-B mode selection".

You can switch the servo amplifier's mode to "J3 compatibility mode" beforehand with the built-in application software "MR-J4(W)-B mode selection" of MR Configurator2. Use it for a solution when it is difficult to reset many times with your "Reset required" controller such as "QD74MH_".

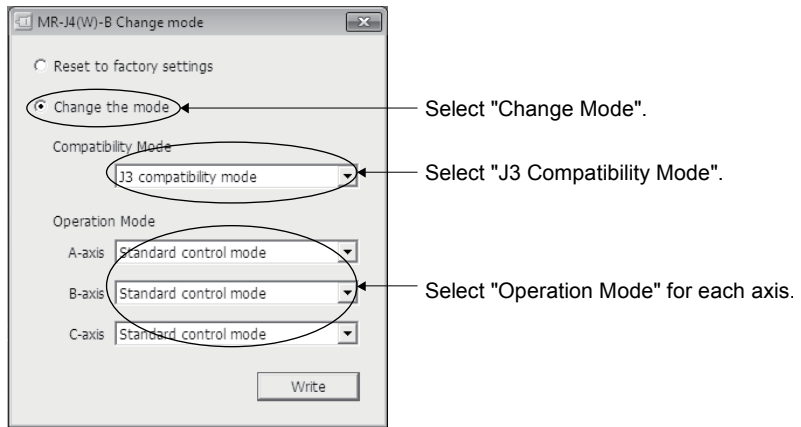

REVISIONS

*The manual number is given on the bottom left of the back cover.

Print Data	*Manual Number	Revision	
Mar. 2012	SH(NA)030105-A	First edition	
Jun. 2012	SH(NA)030105-B	4. Additional instructions (2) Wiring	The sentences are added.
		4. Additional instructions (3) Test run and adjustment	The sentences are added.
		COMPLIANCE WITH CE MARKING	The reference is changed.
		COMPLIANCE WITH UL/CSA STANDARD	The reference is changed.
		COMPLIANCE WITH KC MARK	Added.
		Section 1.2	The diagram is changed.
		Section 1.3.1	The table is changed. Note 8 is added.
		Section 1.3.2	The table is changed. Note 7 and 8 is added.
		Section 1.4	The item of the drive recorder function is changed. The item of the fully closed loop system is changed.
		Section 1.6	The diagram is changed.
		Section 1.7	Note is changed.
		Section 2.6	The explanation of relay lifetime is changed.
		Chapter 3	The sentences are added to CAUTION.
		Section 3.1	The sentences are added to CAUTION. Note 12 is added.
		Section 3.2.1	Note 20 is added.
		Section 3.2.2	Note 20 is added.
		Section 3.3.3 (2) (a)	The ferrule is added.
		Section 3.4	The diagram is added.
		Section 3.5.2 (2)	The sentences of INP (In-position) are added. CLDS (During fully closed loop control) is added.
		Section 3.7.1 (3)	The sentences are added.
		Section 3.8.2 (1)	The sentences are changed.
		Section 3.8.2 (2)	The sentences are added.
		Section 3.8.3 (1)	The sentences are added.
		Section 3.8.3 (2)	The sentences are added.
		Section 4.1.2 (1) (b) 1)	The sentences are changed.
		Section 4.1.2 (1) (b) 4)	Added.
		Section 4.3.3 (1)	The diagram is changed.
		Section 4.5.2 (1) (b)	Note is added. [AL. 20 Encoder normal communication error 1 (ABZ input)] in the table is deleted.
		Section 5.1	POINT is changed and Note is deleted.
		Section 5.1.1	PA25 is changed from "For manufacturer setting".
		Section 5.1.6	PF06 and PF12 are changed from "For manufacturer setting".
		Section 5.2.1	The sentences are added to PA01 and PA20, and PA25 is added.
		Section 5.2.3	The sentences of PC01 are changed and sentences are added to PC03.
		Section 5.2.4	The table of PD07 is changed.
		Section 5.2.5	The sentences are added to PE08.
		Section 5.2.6	PF06 and PF12 are added.
		Chapter 6	The sentences in POINT are changed.
		Section 6.2.2 (4)	The part of table is changed.
		Chapter 7	The sentences in POINT are changed.
		Section 7.3.1	The sentences are added to POINT.
		Section 8.1	The column of the fully closed loop control is added. [AL. 13.2], [AL. 1E.2], [AL. 1F.2], [AL. 21.4], [AL. 42.8], [AL. 42.9], [AL. 42.A], [AL. 70], [AL. 71], [AL. 72], and [AL. E8.2] are added.

Print Data	*Manual Number	Revision	
Jun. 2012	SH(NA)030105-B	Section 8.2	The troubleshooting for the MR-J4W3 servo amplifiers with software version A2 or below.
		Section 10.3	POINT is added.
		Section 11.2.2	The title is changed.
		Section 11.4	Note is changed.
		Section 12.2	The sentences are added to POINT.
		Section 13.1.5	The value in table is changed.
		Section 13.3.2 (1)	The diagram is changed.
		Section 13.3.2 (2)	Added.
		Section 13.3.3	The part of diagram is changed.
		Section 13.4.1 (1)	The sentences are changed.
		Section 13.4.1 (2)	The sentences are added.
		Section 13.4.1 (2) (a)	Note is changed.
		Section 13.4.2 (1)	The sentences are added.
		Section 13.4.2 (2)	The sentences are added.
		Section 14.1.2	CAUTION is changed.
		Section 14.2	CAUTION is added.
		Section 14.3.1 (1)	The diagram is added.
		Section 14.3.1 (2)	"Set the linear servo motor series and linear servo motor type" is added.
		Section 14.3.2 (3) (a)	POINT and sentences are changed.
		Section 14.3.2 (3) (b)	POINT is changed.
		Section 14.4.4	The table is changed and the sentences are added. CAUTION is changed.
		Section 15.2	CAUTION is added.
		Section 15.3.2 (3) (a)	POINT and sentences are changed.
		Section 15.3.2 (3) (b)	POINT is changed.
		Section 15.4.3 (2)	The table is changed.
		Chapter 16	"Available in the future" is deleted. The sentences in POINT are changed.
		Section 16.1.1	The sentences of Note 2 are changed.
		Section 16.1.2 (1)	The part of diagram is changed.
		Section 16.3.1 (5)	The part of table is changed.
		Appendix. 4	The sentences are changed.
		Appendix. 5	The sentences are changed.
		Appendix. 6	The sentences are changed.
Appendix. 7.7.3 (1)	POINT and diagram are changed.		
Appendix. 7.7.3 (2)	The diagram is changed.		
Appendix. 7.7.3 (3)	Deleted.		
Appendix. 7.7.3 (4)	Deleted.		
Appendix. 7.8.1 (1)	The pin number is changed and Note is deleted.		
Appendix. 7.8.1 (2)	CAUTION is deleted.		
Appendix. 7.8.2	The sentences are changed.		
Appendix. 7.12	The diagram is added.		
Appendix. 7.14	POINT is changed.		
Appendix. 8	TUV certificate of MR-J4 series is added.		
Appendix. 10.1	The diagram is changed.		
Appendix. 13 (1)	The wire size of 6) is changed.		
Appendix. 14	Added.		
Sep. 2012	SH(NA)030105-C	Section 3.2.1	The diagram is changed.
		Section 3.2.2	The diagram is changed.
		Section 3.10.2 (1) (b)	The diagram is changed.
		Section 13.3.1	The sentences are changed.

Print Data	*Manual Number	Revision	
Sep. 2012	SH(NA)030105-C	Section 13.4.1 (1) Section 13.4.2 (1)	The diagram is changed. The diagram is changed.
Feb. 2013	SH(NA)030105-D	4. Additional instructions COMPLIANCE WITH CE MARKING COMPLIANCE WITH UL/CSA STANDARD COMPLIANCE WITH KC MARK Compliance with global standards Section 1.3.1 Section 1.3.2 Section 1.3.3 Section 1.4 Chapter 3 Section 3.1 Section 3.3.2 Section 3.4 Section 3.5.2 Section 3.6 Section 3.6.2 Section 3.6.3 Section 3.8.1 Section 3.10.1 (1) Section 4.3.2 (1) Chapter 5 Section 5.1 Section 5.1.4 Section 5.1.6 Section 5.2.1 Section 5.2.2 Section 5.2.3 Section 5.2.6 Section 5.2.7 Section 6.2.2 (2) Section 6.2.2 (4) Section 6.2.2 (5) Section 6.3.1 (1) Section 7.3.2 Section 7.4 Chapter 8 Section 8.1 Section 10.1 Section 10.2 Section 10.3.1 (2) Section 10.3.2 Chapter 11 Section 11.4 (1) Section 11.4 (2) Section 11.5 (1) Section 11.9 (1) (c)	The diagram is partially changed. Deleted. Deleted. Deleted. Added. The table is partially changed. The table is partially changed. The table is changed. HG-UR and HG-JR are added. The table is partially changed. The diagram in CAUTION is partially changed. The diagram is partially changed. POINT is added. The pin name is changed. The table is deleted. The table is partially changed. The sentences are added to POINT. The sentences are partially changed. The sentences are partially changed. The diagram is partially changed. The diagram is partially changed. The diagram is partially changed. The diagram is partially changed. The diagram is partially changed. The sentences are added to CAUTION. POINT is partially changed. The operation mode in [Pr. PD12] is changed. The name of [Pr. PF25] is changed. The name of the third digit is changed. The sentences in [Pr. PB17], [Pr. PB33] to [Pr. PB36], and [Pr. PB56] to [Pr. PB60] are partially changed. The table in [Pr. PC03] is partially changed. The sentences are added to the fourth digit in [Pr. PC04]. The sentences are added to [Pr. PC05]. The name of [Pr. PF25] is changed. The note is added to the first digit in [Pr. PL04]. POINT is added. The table is partially changed. The sentences are added. POINT is partially changed. CAUTION is deleted. The name of [Pr. PF25] is changed. Added. The sentences are added to POINT. Error reset of watchdog is changed. HG-UR and HG-JR are added. HG-UR and HG-JR are added. HG-UR and HG-JR are added. HG-UR and HG-JR are added. POINT is added. The table is partially changed. The table is partially changed. The diagram is partially changed. The table is partially changed.

Print Data	*Manual Number	Revision	
Feb. 2013	SH(NA)030105-D	Section 13.2.2 (2) Section 13.2.2 (3) Section 14.2 Section 14.3.5 (2) (a) Section 15.2 Section 15.3.3 (2) Section 16.1.3 Section 16.2.1 Section 16.3.1 (1) Section 16.3.1 (3) Section 16.3.1 (5) Section 16.3.1 (6) Section 16.3.5 Section 16.3.6 Appendix. 4 Appendix. 12.1 Appendix. 12.5 (3) Appendix. 12.8	The table is partially changed. The sentences are partially changed. The diagram is partially changed. The table is partially changed. The diagram is partially changed. The table is partially changed. The table is partially changed. The diagram is partially changed. The sentences are added. The table is deleted. The diagram is partially changed. Added. The table is partially changed. The table is partially changed. Added. Added. The contents are entirely changed. The sentences are partially changed. The sentences are partially changed. Added.

This manual confers no industrial property rights or any rights of any other kind, nor does it confer any patent licenses. Mitsubishi Electric Corporation cannot be held responsible for any problems involving industrial property rights which may occur as a result of using the contents noted in this manual.

Country/Region	Sales office	Tel/Fax
USA	Mitsubishi Electric Automation Inc. 500 Corporate Woods Parkway, Vernon Hills, IL 60061, USA	Tel : +1-847-478-2100 Fax : +1-847-478-0327
Germany	Mitsubishi Electric Europe B.V. German Branch Gothaer Strasse 8, D-40880 Ratingen, Germany	Tel : +49-2102-486-0 Fax : +49-2102-486-1120
Italy	Mitsubishi Electric Europe B.V. Italian Branch Viale Colleoni 7 1-20041 Agrate Brianza (Milano), Italy	Tel : +39-39-60531 Fax : +39-39-6053312
China	Mitsubishi Electric Automation (China) Ltd. 4F Zhi Fu Plazz, No. 80 Xin Chang Road Shanghai 200003, China	Tel : +86-21-6120-0808 Fax : +86-21-6121-2444
Taiwan	Setsuyo Enterprise Co., Ltd. 6F, No.105 Wu-Kung 3rd Rd, Wu-Ku Hsiang, Taipei Hsine, Taiwan	Tel : +886-2-2299-2499 Fax : +886-2-2299-2509
Korea	Mitsubishi Electric Automation Korea Co., Ltd. 3F, 1480-6, Gayang-dong, Gangseo-gu, Seoul 157-200, Korea	Tel : +82-2-3660-9552 Fax : +82-2-3664-8372
Singapore	Mitsubishi Electric Asia Pte, Ltd. 307 Alexandra Road #05-01/02, Mitsubishi Electric Building Singapore 159943	Tel : +65-6470-2460 Fax : +65-6476-7439

Warranty

1. Warranty period and coverage

We will repair any failure or defect hereinafter referred to as "failure" in our FA equipment hereinafter referred to as the "Product" arisen during warranty period at no charge due to causes for which we are responsible through the distributor from which you purchased the Product or our service provider. However, we will charge the actual cost of dispatching our engineer for an on-site repair work on request by customer in Japan or overseas countries. We are not responsible for any on-site readjustment and/or trial run that may be required after a defective unit are repaired or replaced.

[Term]

The term of warranty for Product is twelve (12) months after your purchase or delivery of the Product to a place designated by you or eighteen (18) months from the date of manufacture whichever comes first ("Warranty Period"). Warranty period for repaired Product cannot exceed beyond the original warranty period before any repair work.

[Limitations]

- (1) You are requested to conduct an initial failure diagnosis by yourself, as a general rule.
It can also be carried out by us or our service company upon your request and the actual cost will be charged. However, it will not be charged if we are responsible for the cause of the failure.
- (2) This limited warranty applies only when the condition, method, environment, etc. of use are in compliance with the terms and conditions and instructions that are set forth in the instruction manual and user manual for the Product and the caution label affixed to the Product.
- (3) Even during the term of warranty, the repair cost will be charged on you in the following cases;
 - (i) a failure caused by your improper storing or handling, carelessness or negligence, etc., and a failure caused by your hardware or software problem
 - (ii) a failure caused by any alteration, etc. to the Product made on your side without our approval
 - (iii) a failure which may be regarded as avoidable, if your equipment in which the Product is incorporated is equipped with a safety device required by applicable laws and has any function or structure considered to be indispensable according to a common sense in the industry
 - (iv) a failure which may be regarded as avoidable if consumable parts designated in the instruction manual, etc. are duly maintained and replaced
 - (v) any replacement of consumable parts (battery, fan, smoothing capacitor, etc.)
 - (vi) a failure caused by external factors such as inevitable accidents, including without limitation fire and abnormal fluctuation of voltage, and acts of God, including without limitation earthquake, lightning and natural disasters
 - (vii) a failure generated by an unforeseeable cause with a scientific technology that was not available at the time of the shipment of the Product from our company
 - (viii) any other failures which we are not responsible for or which you acknowledge we are not responsible for

2. Term of warranty after the stop of production

- (1) We may accept the repair at charge for another seven (7) years after the production of the product is discontinued. The announcement of the stop of production for each model can be seen in our Sales and Service, etc.
- (2) Please note that the Product (including its spare parts) cannot be ordered after its stop of production.

3. Service in overseas countries

Our regional FA Center in overseas countries will accept the repair work of the Product. However, the terms and conditions of the repair work may differ depending on each FA Center. Please ask your local FA center for details.

4. Exclusion of responsibility for compensation against loss of opportunity, secondary loss, etc.

Whether under or after the term of warranty, we assume no responsibility for any damages arisen from causes for which we are not responsible, any losses of opportunity and/or profit incurred by you due to a failure of the Product, any damages, secondary damages or compensation for accidents arisen under a specific circumstance that are foreseen or unforeseen by our company, any damages to products other than the Product, and also compensation for any replacement work, readjustment, start-up test run of local machines and the Product and any other operations conducted by you.

5. Change of Product specifications

Specifications listed in our catalogs, manuals or technical documents may be changed without notice.

6. Application and use of the Product

- (1) For the use of our General-Purpose AC Servo, its applications should be those that may not result in a serious damage even if any failure or malfunction occurs in General-Purpose AC Servo, and a backup or fail-safe function should operate on an external system to General-Purpose AC Servo when any failure or malfunction occurs.
- (2) Our General-Purpose AC Servo is designed and manufactured as a general purpose product for use at general industries. Therefore, applications substantially influential on the public interest for such as atomic power plants and other power plants of electric power companies, and also which require a special quality assurance system, including applications for railway companies and government or public offices are not recommended, and we assume no responsibility for any failure caused by these applications when used
In addition, applications which may be substantially influential to human lives or properties for such as airlines, medical treatments, railway service, incineration and fuel systems, man-operated material handling equipment, entertainment machines, safety machines, etc. are not recommended, and we assume no responsibility for any failure caused by these applications when used. We will review the acceptability of the abovementioned applications, if you agree not to require a specific quality for a specific application. Please contact us for consultation.

MODEL	MR-J4W-B INSTRUCTIONMANUAL
MODEL CODE	1CW806

MITSUBISHI ELECTRIC CORPORATION

HEAD OFFICE : TOKYO BLDG MARUNOUCHI TOKYO 100-8310