

MELSEC FX series

Programmable Controllers



User's Manual



FX3U-4LC

Safety Precautions

(Read these precautions before using.)

Before installation, operation, maintenance or inspection of this product, thoroughly read through and understand this manual and the associated manuals. Also, take care to handle the module properly and safely.

This manual classifies the safety precautions into two categories:  **DANGER** and  **CAUTION**.

 DANGER	Indicates that incorrect handling may cause hazardous conditions, resulting in death or severe injury.
 CAUTION	Indicates that incorrect handling may cause hazardous conditions, resulting in medium or slight personal injury or physical damage.

Depending on the circumstances, procedures indicated by  **CAUTION** may also cause severe injury.

It is important to follow all precautions for personal safety.

Store this manual in a safe place so that it can be taken out and read whenever necessary. Always forward it to the end user.

1. DESIGN PRECAUTIONS

 DANGER	Reference
<ul style="list-style-type: none"> • Make sure to include the following safety circuits outside the PLC to ensure safe system operation even during external power supply problems or PLC failure. Otherwise, malfunctions may cause serious accidents. <ol style="list-style-type: none"> 1) Above all, the following components should be included: an emergency stop circuit, a protection circuit, an interlock circuit for opposite movements (such as normal vs. reverse rotation), and an interlock circuit (to prevent damage to the equipment at the upper and lower positioning limits). 2) Note that when the PLC CPU detects an error, such as a watchdog timer error, during self-diagnosis, all outputs are turned off. Also, when an error that cannot be detected by the PLC CPU occurs in an input/output control block, output control may be disabled. External circuits and mechanisms should be designed to ensure safe machinery operation in such a case. 3) Note that when an error occurs in a relay, triac or transistor output device, the output could be held either on or off. For output signals that may lead to serious accidents, external circuits and mechanisms should be designed to ensure safe machinery operation in such a case. 	17

 CAUTION	Reference
<ul style="list-style-type: none"> • Do not bundle the control line together with or lay it close to the main circuit or power line. As a guideline, lay the control line at least 100mm (3.94") or more away from the main circuit or power line. Noise may cause malfunctions. • Ground the shield wire or shield of the shielded cable at one point on the PLC. However, do not ground them at the same point as the high-voltage lines. Noise may cause malfunctions. • Install module so that excessive force will not be applied to the terminal blocks. Failure to do so may result in wire damage/breakage or PLC failure. 	17

Safety Precautions

(Read these precautions before using.)

2. INSTALLATION PRECAUTIONS

 DANGER	Reference
<ul style="list-style-type: none"> • Make sure to shut down all phases of the power supply externally before installing. Failure to do so may cause electric shock or damage to the product. 	24

 CAUTION	Reference
<ul style="list-style-type: none"> • Use the product within the generic environment specifications described in PLC main unit manual (Hardware Edition). Never use the product in areas with excessive dust, oily smoke, conductive dusts, corrosive gas (salt air, Cl₂, H₂S, SO₂, or NO₂), flammable gas, vibration or impacts, or expose it to high temperature, condensation, or rain and wind. If the product is used in such conditions, electric shock, fire, malfunctions, deterioration or damage may occur. • Do not touch the conductive parts of the product directly. Doing so may cause device failures or malfunctions. • Install the product securely using a DIN rail or mounting screws. • Install the product on a flat surface. If the mounting surface is rough, undue force will be applied to the PC board, thereby causing nonconformities. • When drilling screw holes or wiring, make sure that cutting and wiring debris do not enter the ventilation slits. Failure to do so may cause fire, equipment failures or malfunctions. • Be sure to remove the dust proof sheet from the PLC's ventilation port when installation work is completed. Failure to do so may cause fire, equipment failures or malfunctions. • Connect extension cables securely to their designated connectors. Loose connections may cause malfunctions. • Turn off the power to the PLC before attaching or detaching the following devices. Failure to do so may cause device failures or malfunctions. <ul style="list-style-type: none"> - Peripheral devices, display modules, expansion boards and special adapters - I/O extension units/blocks, FX Series terminal block and the special function units/blocks - Battery and memory cassette 	24

3. WIRING PRECAUTIONS

 DANGER	Reference
<ul style="list-style-type: none"> • Make sure to cut off all phases of the power supply externally before attempting wiring work. Failure to do so may cause electric shock. 	27

 CAUTION	Reference
<ul style="list-style-type: none"> • Connect the AC power supply to the dedicated terminals specified in this manual. If an AC power supply is connected to a DC input/output terminal or DC power supply terminal, the PLC will burn out. • Do not wire vacant terminals externally. Doing so may damage the product. • Use class D grounding (grounding resistance of 100Ω or less) with a wire of 2mm² or thicker on the grounding terminal of the PLC. However, do not connect the ground terminal at the same point as a heavy electrical system. • When drilling screw holes or wiring, make sure cutting or wire debris does not enter the ventilation slits. Failure to do so may cause fire, equipment failures or malfunctions. • Make sure to observe the following precautions in order to prevent malfunctions under the influence of noise. <ul style="list-style-type: none"> - Do not bundle the power line or twisted shielded cable together with or lay it close to the main circuit, high-voltage line, or load line. Otherwise, noise disturbance and/or surge induction are likely to take place. As a guideline, lay the control line at least 100mm (3.94") or more away from the main circuit, high-voltage line, or load line. - Ground the shield wire or shield of the shielded cable at one point on the PLC. However, do not use common grounding with heavy electrical systems. • Make sure to properly wire to the terminal blocks in accordance with the following precautions. Failure to do so may cause electric shock, equipment failures, a short-circuit, wire breakage, malfunctions, or damage to the product. <ul style="list-style-type: none"> - The disposal size of the cable end should follow the dimensions described in the manual. - Tightening torque should follow the specifications in the manual. 	27

Safety Precautions

(Read these precautions before using.)

4. STARTUP AND MAINTENANCE PRECAUTIONS

 DANGER	Reference
<ul style="list-style-type: none"> • Do not touch any terminal while the PLC's power is on. Doing so may cause electric shock or malfunctions. • Before cleaning or retightening terminals, cut off all phases of the power supply externally. Failure to do so may cause electric shock. • Before modifying or disrupting the program in operation or running the PLC, carefully read through this manual and the associated manuals and ensure the safety of the operation. An operation error may damage the machinery or cause accidents. 	125 141

 CAUTION	Reference
<ul style="list-style-type: none"> • Do not disassemble or modify the PLC. Doing so may cause fire, equipment failures, or malfunctions. For repair, contact your local Mitsubishi Electric distributor. • Turn off the power to the PLC before connecting or disconnecting any extension cable. Failure to do so may cause equipment failures or malfunctions. • Turn off the power to the PLC before attaching or detaching the following devices. Failure to do so may cause equipment failures or malfunctions. <ul style="list-style-type: none"> - Peripheral devices, display modules, expansion boards and special adapters - I/O extension units/blocks, FX Series terminal block and the special function units/blocks - Battery and memory cassette 	125 141

5. DISPOSAL PRECAUTIONS

 CAUTION	Reference
<ul style="list-style-type: none"> • Please contact a certified electronic waste disposal company for the environmentally safe recycling and disposal of your device. 	17

6. TRANSPORTATION PRECAUTIONS

 CAUTION	Reference
<ul style="list-style-type: none"> • The PLC is a precision instrument. During transportation, avoid impacts larger than those specified in the general specifications of the PLC main unit manual. Failure to do so may cause failures in the PLC. After transportation, verify the operations of the PLC. 	17

MEMO

FX3U-4LC

User's Manual

Manual number	JY997D39101
Manual revision	B
Date	5/2010

Foreword

This manual describes the FX3U-4LC temperature control block and should be read and understood before attempting to install the hardware.

Store this manual in a safe place so that you can take it out and read it whenever necessary. Always forward it to the end user.

This manual confers no industrial property rights or any rights of any other kind, nor does it confer any patent licenses. Mitsubishi Electric Corporation cannot be held responsible for any problems involving industrial property rights which may occur as a result of using the contents noted in this manual.

Outline Precautions

- This manual provides information for the use of the FX3U-4LC temperature control block. The manual has been written to be used by trained and competent personnel. The definition of such a person or persons is as follows;
 - 1) Any engineer who is responsible for the planning, design and construction of automatic equipment using the product associated with this manual should be of a competent nature, trained and qualified to the local and national standards required to fulfill that role. These engineers should be fully aware of all aspects of safety with aspects regarding to automated equipment.
 - 2) Any commissioning or maintenance engineer must be of a competent nature, trained and qualified to the local and national standards required to fulfill the job. These engineers should also be trained in the use and maintenance of the completed product. This includes being familiar with all associated manuals and documentation for the product. All maintenance should be carried out in accordance with established safety practices.
 - 3) All operators of the completed equipment should be trained to use that product in a safe and coordinated manner in compliance with established safety practices. The operators should also be familiar with documentation that is connected with the actual operation of the completed equipment.
- Note:** the term 'completed equipment' refers to a third party constructed device that contains or uses the product associated with this manual.
- This product has been manufactured as a general-purpose part for general industries, and has not been designed or manufactured to be incorporated in a device or system used in purposes related to human life.
 - Before using the product for special purposes such as nuclear power, electric power, aerospace, medicine or passenger movement vehicles, consult with Mitsubishi Electric.
 - This product has been manufactured under strict quality control. However when installing the product where major accidents or losses could occur if the product fails, install appropriate backup or failsafe functions into the system.
 - When combining this product with other products, please confirm the standards and codes of regulation to which the user should follow. Moreover, please confirm the compatibility of this product with the system, machines, and apparatuses to be used.
 - If there is doubt at any stage during installation of the product, always consult a professional electrical engineer who is qualified and trained in the local and national standards. If there is doubt about the operation or use, please consult the nearest Mitsubishi Electric distributor.
 - Since the examples within this manual, technical bulletin, catalog, etc. are used as reference; please use it after confirming the function and safety of the equipment and system. Mitsubishi Electric will not accept responsibility for actual use of the product based on these illustrative examples.
 - The content, specification etc. of this manual may be changed for improvement without notice.
 - The information in this manual has been carefully checked and is believed to be accurate; however, if you notice any doubtful point, error, etc., please contact the nearest Mitsubishi Electric distributor.

Registration

- The company name and the product name to be described in this manual are the registered trademarks or trademarks of each company.

Table of Contents

SAFETY PRECAUTIONS	(1)
Standards.....	7
Certification of UL, cUL standards	7
Compliance with EC directive (CE Marking)	7
Associated Manuals.....	9
Generic Names and Abbreviations Used in the Manual	11
Reading the Manual	13

1. Introduction **14**

1.1 Outline.....	14
1.1.1 Major features of the FX3U-4LC	14
1.2 External Dimensions and Part Names	15
1.3 Terminal Layout	16
1.4 Power and Status LEDs	16

2. Specification **17**

2.1 General Specifications	18
2.2 Power Supply Specifications.....	18
2.3 Performance Specifications	18
2.4 Input Specifications	19
2.4.1 Temperature input specifications.....	19
2.4.2 Measurement precision	20
2.4.3 Current detector (CT) input specifications	20
2.5 Input Type	21
2.6 Output Specifications	21

3. System Configuration **22**

3.1 General Configuration.....	22
3.2 Applicable PLC.....	23
3.3 Connection with PLC.....	23

4. Installation **24**

4.1 DIN rail Mounting	25
4.2 Direct Mounting.....	26

5. Wiring **27**

5.1 Power Supply Wiring.....	28
5.1.1 Power supply wiring.....	28
5.1.2 Grounding.....	28
5.2 Input Wiring	29
5.2.1 Wiring example of thermocouple	29
5.2.2 Wiring example of resistance thermometer	29
5.2.3 Wiring example of micro voltage input.....	30
5.3 Output Wiring	31
5.4 Terminal Screw and Tightening Torque	32

6. Introduction of Functions

33

6.1 Functions List	33
6.2 Control Mode Switch Function	34
6.3 Transistor Output Selection Function	36
6.4 PID control	38
6.4.1 Easy PID control with two degrees of freedom	38
6.4.2 Overshoot prevention function	39
6.5 Two-position Control	40
6.6 Heating/cooling PID control	41
6.6.1 Heating/cooling PID control	41
6.6.2 Overshoot prevention function	42
6.6.3 Overlap/dead band function	43
6.6.4 Cooling method	44
6.7 Cascade control	45
6.7.1 Cascade control	45
6.7.2 Tuning during cascade control	47
6.7.3 SV tracking selection function	48
6.8 Auto Tuning Function	49
6.8.1 AT (Auto tuning)	49
6.8.2 Conditions for performing and aborting AT (auto tuning)	51
6.8.3 AT (auto tuning) bias	53
6.9 Startup Tuning Function	54
6.9.1 ST (startup tuning)	54
6.9.2 Conditions for performing and aborting ST (startup tuning)	56
6.10 AUTO/MANUAL mode changeover	58
6.10.1 AUTO mode and MANUAL mode	58
6.10.2 Balance-less, bump-less function	59
6.11 Heater Disconnection Alarm Function (HBA)	60
6.11.1 Heater disconnection alarm function	60
6.11.2 Number of times of heater disconnection alarm delay	61
6.12 Loop Breaking Alarm Function (LBA)	62
6.12.1 Loop breaking alarm function	62
6.12.2 Loop breaking alarm dead zone (LBD)	64

7. Alarm

65

7.1 Alarm List	65
7.2 Alarm Functions	67
7.2.1 Upper limit input value alarm	67
7.2.2 Lower limit input value alarm	67
7.2.3 Upper limit deviation alarm	68
7.2.4 Lower limit deviation alarm	68
7.2.5 Upper/lower limit deviation	68
7.2.6 Range alarm	69
7.2.7 Alarm wait operation	69
7.2.8 Alarm re-wait operation	70
7.3 Alarm Dead Zone Setting	71
7.4 Number of Times of Alarm Delay	72

8. Buffer Memory

73

8.1 Buffer Memory List	73
8.2 Buffer Memory Details.....	77
8.2.1 [BFM#0] Flag	77
8.2.2 [BFM#1 to 4] Event.....	78
8.2.3 [BFM#5 to 8] Measured value (PV)	79
8.2.4 [BFM#9 to 12] Control output value (MV) monitor/ Heating control output value (MV) monitor	80
8.2.5 [BFM#13 to 16] Cooling control output value (MV) monitor.....	80
8.2.6 [BFM#17 to 20] Control output flag.....	81
8.2.7 [BFM#21 to 24] Heater current measured value	82
8.2.8 [BFM#25 to 28] External input value	82
8.2.9 [BFM#29] Control start/stop changeover.....	82
8.2.10 [BFM#30] FX Series model code.....	82
8.2.11 [BFM#32 to 35] External output value/Heating external output value monitor	83
8.2.12 [BFM#36 to 39] Cooling external output value monitor	83
8.2.13 [BFM#40 to 43] Set value monitor	83
8.2.14 [BFM#44 to 47] Control mode monitor	84
8.2.15 [BFM#48][BFM#88][BFM#128][BFM#168] Set value (SV).....	85
8.2.16 [BFM#49 to 52][BFM#89 to 92][BFM#129 to 132][BFM#169 to 172] Alarm setting value 1 to 4	85
8.2.17 [BFM#53][BFM#93][BFM#133][BFM#173] Heater disconnection alarm set value.....	86
8.2.18 [BFM#54][BFM#94][BFM#134][BFM#174] AUTO/MANUAL mode changeover	86
8.2.19 [BFM#55][BFM#95][BFM#135][BFM#175] MANUAL output set value.....	87
8.2.20 [BFM#56][BFM#96][BFM#136][BFM#176] AT (auto tuning) execution command	87
8.2.21 [BFM#57][BFM#97][BFM#137][BFM#177] Operation mode	88
8.2.22 [BFM#58][BFM#98][BFM#138][BFM#178] Proportional band (P)/ Heating proportional band (P).....	89
8.2.23 [BFM#59][BFM#99][BFM#139][BFM#179] Cooling proportional band (P)	89
8.2.24 [BFM#60][BFM#100][BFM#140][BFM#180] Integral time (I).....	90
8.2.25 [BFM#61][BFM#101][BFM#141][BFM#181] Derivative time (D)	90
8.2.26 [BFM#62][BFM#102][BFM#142][BFM#182] Control response parameter	91
8.2.27 [BFM#63][BFM#103][BFM#143][BFM#183] Overlap/Dead band	92
8.2.28 [BFM#64][BFM#104][BFM#144][BFM#184] Output limiter upper limit/ Heating upper output limiter.....	93
8.2.29 [BFM#65][BFM#105][BFM#145][BFM#185] Output limiter lower limit.....	94
8.2.30 [BFM#66][BFM#106][BFM#146][BFM#186] Cooling upper output limiter setting.....	94
8.2.31 [BFM#67][BFM#107][BFM#147][BFM#187] Output change ratio limiter.....	95
8.2.32 [BFM#68][BFM#108][BFM#148][BFM#188] Sensor correction value setting.....	96
8.2.33 [BFM#69][BFM#109][BFM#149][BFM#189] Adjustment sensitivity (dead zone) setting.....	97
8.2.34 [BFM#70][BFM#110][BFM#150][BFM#190] Control output cycle setting/ Heating control output period setting	98
8.2.35 [BFM#71][BFM#111][BFM#151][BFM#191] Cooling control output period setting.....	98
8.2.36 [BFM#72][BFM#112][BFM#152][BFM#192] Primary delay digital filter setting	99
8.2.37 [BFM#73][BFM#113][BFM#153][BFM#193] Setting change ratio limiter.....	100
8.2.38 [BFM#74][BFM#114][BFM#154][BFM#194] AT (auto tuning) bias.....	101
8.2.39 [BFM#75][BFM#115][BFM#155][BFM#195] Normal/reverse operation selection	102
8.2.40 [BFM#76][BFM#116][BFM#156][BFM#196] Setting limiter upper limit.....	103
8.2.41 [BFM#77][BFM#117][BFM#157][BFM#197] Setting limiter lower limit	103
8.2.42 [BFM#78][BFM#118][BFM#158][BFM#198] Loop breaking alarm judgement time.....	104
8.2.43 [BFM#79][BFM#119][BFM#159][BFM#199] Loop breaking alarm dead zone.....	105
8.2.44 [BFM#80][BFM#120][BFM#160][BFM#200] Micro voltage input scaling upper limit	106
8.2.45 [BFM#81][BFM#121][BFM#161][BFM#201] Micro voltage input scaling lower limit.....	106
8.2.46 [BFM#82][BFM#122][BFM#162][BFM#202] External input range upper limit	106
8.2.47 [BFM#83][BFM#123][BFM#163][BFM#203] External input range lower limit.....	106
8.2.48 [BFM#84][BFM#124][BFM#164][BFM#204] External output range upper limit	107
8.2.49 [BFM#85][BFM#125][BFM#165][BFM#205] External output range lower limit.....	107
8.2.50 [BFM#86][BFM#126][BFM#166][BFM#206] Transistor output selection.....	108
8.2.51 [BFM#87][BFM#127][BFM#167][BFM#207] ST (startup tuning) execution command	109
8.2.52 [BFM#208][BFM#214][BFM#220][BFM#226] Input type	110
8.2.53 [BFM#209 to #212][BFM#215 to #218][BFM#221 to #224][BFM#227 to #230] Alarm mode setting 1 to 4.....	111

8.2.54 [BFM#232] Cooling method setting	112
8.2.55 [BFM#233] Alarm dead band setting	113
8.2.56 [BFM#234] Alarm delay count	114
8.2.57 [BFM#235] Number of times of heater disconnection alarm delay/ Number of times of current error detection when output is OFF delay	115
8.2.58 [BFM#236] Temperature rise completion range setting	115
8.2.59 [BFM#237] Temperature rise completion soak time	116
8.2.60 [BFM#238] CT monitor method switch	117
8.2.61 [BFM#239] CT ratio setting	117
8.2.62 [BFM#240, #241] Control mode switch	118
8.2.63 [BFM#242, #243] SV tracking selection	119
8.2.64 [BFM#244, #245] Cascade ON/OFF	120
8.2.65 [BFM#246, #247] Cascade gain	120
8.2.66 [BFM#248, #249] Cascade bias	121
8.2.67 [BFM#250, #251] Cascade monitor	121
8.2.68 [BFM#252] Set value range error address	122
8.2.69 [BFM#253] Error reset command	122
8.2.70 [BFM#254] Set value backup command	123
8.2.71 [BFM#255] Initialization command	124

9. Program Examples **125**

9.1 Reading/Writing Buffer Memory	126
9.1.1 Assigned unit number	126
9.1.2 How to read/write from/to buffer memory	126
9.2 Example of a Program for PID Control	131
9.2.1 System configuration	131
9.2.2 Conditions of operation	131
9.2.3 Device assignments	132
9.2.4 Sequence program	133
9.3 Example of a Program for Heating/Cooling PID Control	136
9.3.1 System configuration	136
9.3.2 Conditions of operation	136
9.3.3 Device assignments	137
9.3.4 Sequence program	138

10. Troubleshooting **141**

10.1 Troubleshooting Procedure	142
10.1.1 How to reset an error	142
10.2 Diagnostics on the PLC Main Unit	143
10.2.1 POWER (POW) LED [on/flashing/off]	143
10.2.2 BATT (BAT) LED [on/off]	143
10.2.3 ERROR (ERR) LED [on/flashing/off]	144

Appendix A: Version Information **145**

Appendix A-1 Version Information	145
Appendix A-1-1 Version check method	145
Appendix A-1-2 Version upgrade history	145

Warranty

Revised History

Standards

Certification of UL, cUL standards

FX3U-4LC units comply with the UL standards (UL, cUL).

UL, cUL File number :E95239

Regarding the standards that comply with the main unit, please refer to either the FX series product catalog or consult with your nearest Mitsubishi product provider.

Compliance with EC directive (CE Marking)

This document does not guarantee that a mechanical system including this product will comply with the following standards.

Compliance to EMC directive and LVD directive for the entire mechanical module should be checked by the user / manufacturer. For more information please consult with your nearest Mitsubishi product provider.

Regarding the standards that comply with the main unit, please refer to either the FX series product catalog or consult with your nearest Mitsubishi product provider.

Requirement for Compliance with EMC directive

The following products have shown compliance through direct testing (of the identified standards below) and design analysis (through the creation of a technical construction file) to the European Directive for Electromagnetic Compatibility (2004/108/EC) when used as directed by the appropriate documentation.

Attention

- This product is designed for use in industrial applications.

Note

- Manufactured by:
Mitsubishi Electric Corporation
2-7-3 Marunouchi, Chiyoda-ku, Tokyo, 100-8310 Japan
- Manufactured at:
Mitsubishi Electric Corporation Himeji Works
840 Chiyoda-machi, Himeji, Hyogo, 670-8677 Japan
- Authorized Representative in the European Community:
Mitsubishi Electric Europe B.V.
Gothaer Str. 8, 40880 Ratingen, Germany

Type: Programmable Controller (Open Type Equipment)

Models: MELSEC FX3U series manufactured
from December 1st, 2009 FX3U-4LC

Standard	Remark
EN61131-2:2007 Programmable controllers - Equipment requirements and tests	Compliance with all relevant aspects of the standard. EMI <ul style="list-style-type: none"> • Radiated Emissions • Conducted Emissions EMS <ul style="list-style-type: none"> • Radiated electromagnetic field • Fast Transient burst • Electrostatic discharge • High-energy surge • Voltage drops and interruptions • Conducted RF • Power frequency magnetic field

Caution to conform with EC Directives

The FX3U-4LC have been found to be compliant to the European standards in the aforesaid manual and directive. However, for the very best performance from what are in fact delicate measuring and controlled output device Mitsubishi Electric would like to make the following points;

As analog devices are sensitive by nature, their use should be considered carefully. For users of proprietary cables (integral with sensors or actuators), these users should follow those manufacturers installation requirements.

Mitsubishi Electric recommend that shielded cables should be used. If NO other EMC protection is provided, then users may experience temporary loss or accuracy between $\pm 10\%$ in very heavy industrial areas.

However, Mitsubishi Electric suggest that if adequate EMC precautions are followed for the users complete control system, users should expect accuracy as specified in this manual.

- Sensitive analog cable should not be laid in the same trunking or cable conduit as high voltage cabling. Where possible users should run analog cables separately.
- Good cable shielding should be used. When terminating the shield at Earth - ensure that no earth loops are accidentally created.
- When reading analog values, EMC accuracy can be improved out by averaging the readings. This can be achieved either through functions on the analog special function blocks for or through a users program in the FX3G/FX3U/FX3UC Series PLC main unit.
- Installation in Enclosure
Programmable logic controllers are open-type devices that must be installed and used within conductive control cabinets. Please use the programmable logic controller while installed within a conductive shielded control cabinet. Please secure the cabinet door to the control cabinet (for conduction).
Installation within a control cabinet greatly affects the safety of the system and aids in shielding noise from the programmable logic controller.

Associated Manuals

Only the installation manual is packed together with the FX3U-4LC temperature control block.
For a detailed explanation of the FX3U-4LC temperature control block, refer to this manual.
For the hardware information and instructions on the PLC main unit, refer to the respective manuals.

- ⊙ Refer to these manuals
- ✓ Refer to the appropriate equipment manual
- △ For a detailed explanation, refer to an additional manual

		Title of manual	Document number	Description	Model code
Manual for the Main Unit					
FX3G Series PLCs Main Unit					
△	Supplied Manual	FX3G Series Hardware Manual	JY997D33401	Describes FX3G Series PLC specification for I/O, wiring and installation extracted from the FX3G User's Manual - Hardware Edition. For details, refer to FX3G Series User's Manual - Hardware Edition.	-
⊙	Additional Manual	FX3G Series User's Manual - Hardware Edition	JY997D31301	Describes FX3G Series PLC specification details for I/O, wiring, installation and maintenance.	09R521
FX3U Series PLCs Main Unit					
△	Supplied Manual	FX3U Series Hardware Manual	JY997D18801	Describes FX3U Series PLC specification for I/O, wiring and installation extracted from the FX3U User's Manual - Hardware Edition. For details, refer to FX3U Series User's Manual - Hardware Edition.	-
⊙	Additional Manual	FX3U Series User's Manual - Hardware Edition	JY997D16501	Describes FX3U Series PLC specification details for I/O, wiring, installation and maintenance.	09R516
FX3UC Series PLCs Main Unit					
△	Supplied Manual	FX3UC(D,DSS) Series Hardware Manual	JY997D28601	Describes FX3UC(D,DSS) Series PLC specification for I/O, wiring and installation extracted from the FX3UC Series User's Manual - Hardware Edition. For details, refer to FX3UC Series User's Manual - Hardware Edition.	-
△	Supplied Manual	FX3UC-32MT-LT-2 Hardware Manual	JY997D31601	Describes FX3UC-32MT-LT-2 specification for I/O, wiring and installation extracted from the FX3UC User's Manual - Hardware Edition. For details, refer to FX3UC Series User's Manual - Hardware Edition.	-
△	Supplied Manual	FX3UC-32MT-LT Hardware Manual (Only Japanese document)	JY997D12701	Describes FX3UC-32MT-LT specification for I/O, wiring and installation extracted from the FX3UC User's Manual - Hardware Edition. For details, refer to FX3UC Series User's Manual - Hardware Edition.	-
⊙	Additional Manual	FX3UC Series User's Manual - Hardware Edition	JY997D28701	Describes FX3UC Series PLC specification details for I/O, wiring, installation and maintenance.	09R519
Programming for FX3G/FX3U/FX3UC Series					
⊙	Additional Manual	FX3G/FX3U/FX3UC Series Programming Manual - Basic & Applied Instruction Edition	JY997D16601	Describes FX3G/FX3U/FX3UC Series PLC programming for basic/applied instructions and devices.	09R517
Manuals for analog control					
⊙	Additional Manual	FX3G/FX3U/FX3UC Series User's Manual - Analog Control Edition	JY997D16701	Details of analog special function block (FX3U-4AD, FX3U-4DA, FX3UC-4AD) and analog special adapter (FX3U-***-**-ADP)	09R619

		Title of manual	Document number	Description	Model code
Manuals for FX3U-4LC temperature control block					
△	Supplied Manual	FX3U-4LC Installation Manual	JY997D38901	Describes installation specifications for the FX3U-4LC temperature control block extracted from the FX3U-4LC User's Manual. For details, refer to FX3U-4LC User's Manual.	-
⊙	Additional Manual	FX3U-4LC User's Manual (This Manual)	JY997D39101	Describes details of the FX3U-4LC temperature control block.	09R625

Generic Names and Abbreviations Used in the Manual

Generic name or abbreviation	Description
PLC	
FX3G series	Generic name for FX3G Series PLC
FX3G PLC or main unit	Generic name for FX3G Series PLC main unit
FX3U series	Generic name for FX3U Series PLC
FX3U PLC or main unit	Generic name for FX3U Series PLC main unit
FX3UC series	Generic name for FX3UC Series PLC
FX3UC PLC or main unit	Generic name for FX3UC Series PLC main unit
Expansion board	
Expansion board	Generic name for expansion board The number of connectable units, however, depends on the type of main unit. To check the number of connectable units, refer to the User's Manual - Hardware Edition of the main unit to be used for your system.
Special adapter	
Special adapter	Generic name for high-speed input/output special adapter, communication special adapter, analog special adapter, and CF card special adapter. The number of connectable units, however, depends on the type of main unit. To check the number of connectable units, refer to the User's Manual - Hardware Edition of the main unit to be used for your system.
Extension equipment	
I/O extension unit/block	Generic name for input/output powered extension unit and input/output extension block The number of connectable units, however, depends on the type of main unit. To check the number of connectable units, refer to the User's Manual - Hardware Edition of the main unit to be used for your system.
Special function unit/block or Special extension unit	Generic name for special function unit and special function block The number of connectable units, however, depends on the type of main unit. To check the number of connectable units, refer to the User's Manual - Hardware Edition of the main unit to be used for your system.
Special function unit	Generic name for special function unit
Special function block	Generic name for special function block The number of connectable units, however, depends on the type of main unit. To check the number of connectable units, refer to the User's Manual - Hardware Edition of the main unit to be used for your system.
4LC	Abbreviated name for FX3U-4LC
Optional unit	
Memory cassette	Generic name for FX3U-FLROM-16, FX3U-FLROM-64, FX3U-FLROM-64L
Battery	Abbreviated name for FX3U-32BL
FX Series terminal block	FX-16E-TB, FX-32E-TB, FX-16EX-A1-TB, FX-16EYR-TB, FX-16EYT-TB, FX-16EYT-H-TB, FX-16EYS-TB, FX-16E-TB/UL, FX-32E-TB/UL, FX-16EYR-ES-TB/UL, FX-16EYT-ES-TB/UL, FX-16EYT-ESS-TB/UL, FX-16EYS-ES-TB/UL
Peripheral unit	
Peripheral unit	Generic name for programming software, handy programming panel, and indicator
Programming tool	
Programming tool	Generic name for programming software and handy programming panel
Programming software	Generic name for programming software
GX Developer	Generic name for SW□D5C-GPPW-J/SW□D5C-GPPW-E programming software package
FX-PCS/WIN(-E)	Generic name for FX-PCS/WIN or FX-PCS/WIN-E programming software package
Handy programming panel (HPP)	Generic name for FX-30P, FX-20P-SET0, FX-20P, FX-20P-E-SET0 and FX-20P-E
Indicator	
GOT1000 series	Generic name for GT15, GT11 and GT10
GOT-900 series	Generic name for GOT-A900 series and GOT-F900 series
GOT-A900 series	Generic name for GOT-A900 series
GOT-F900 series	Generic name for GOT-F900 series
ET-940 series	Generic name for ET-940 series Only manuals in Japanese are available for these products

Generic name or abbreviation	Description
Manual	
FX3G Hardware Edition	FX3G Series User's Manual - Hardware Edition
FX3U Hardware Edition	FX3U Series User's Manual - Hardware Edition
FX3UC Hardware Edition	FX3UC Series User's Manual - Hardware Edition
Programming manual	FX3G/FX3U/FX3UC Series Programming Manual - Basic and Applied Instructions Edition
Communication control Edition	FX Series User's Manual - Data Communication Edition
Analog control Edition	FX3G/FX3U/FX3UC Series User's Manual - Analog Control Edition
Positioning control Edition	FX3G/FX3U/FX3UC Series User's Manual - Positioning Control Edition

Reading the Manual

In this manual, the following formats are used for describing the common items.

- Shows the manual title.**
This area shows the manual title for the current page.
- Shows the title of the chapter and the title of the section.**
This area shows the title of the chapter and the title of the section for the current page.
- Indexes the chapter number.**
The right side of each page indexes the chapter number for the page currently opened.

FX3U-4LC User's Manual

3 System Configuration
3.2 Applicable PLC

3.2 Applicable PLC

Model name	Applicability
FX3G Series PLC	Ver. 1.00 and later (Up to 8 blocks can be extended)
FX3U Series PLC	Ver. 2.20 and later (Up to 8 blocks can be extended)
FX3UC Series PLC*1	Ver. 2.20 and later (Up to 8 blocks can be extended ²⁾)

The version number can be checked by reading the last three digits of device D8001.

*1. An FX2nc-CNV-IF or FX3uc-1PS-5V is necessary to connect the 4LC with the FX3uc PLC.
*2. Up to 7 units can be connected to the FX3uc-32MT-LT(-2) PLC.

3.3 Connection with PLC

The 4LC connects with a PLC via an extension cable.
The 4LC is handled as a special extension block of the PLC. The unit number of the 4LC is automatically assigned No.0 to No.7 (Unit No.1 to No.7 is assigned when the main unit is an FX3uc-32MT-LT(-2).) starting from the special function unit/block closest to the PLC main unit.
(This unit number is used for the designation of a FROM/TO instruction.)
For details on the assignment of the I/O number and unit number of the PLC, refer to the following manual corresponding to the connected PLC.

→ Refer to FX3g Hardware Edition.
→ Refer to FX3u Hardware Edition.
→ Refer to FX3uc Hardware Edition.

- An FX2nc-CNV-IF or FX3uc-1PS-5V is necessary to connect the 4LC with the FX3uc PLC.
- The number of I/O points occupied by the 4LC is eight. Make sure that the total number of I/O points (occupied I/O points) of the main unit, extension unit(s), extension block(s) and the number of points occupied by special function blocks does not exceed the maximum number of I/O points of the PLC. For information on the maximum number of I/O points of the PLC, refer to the respective product manual.
→ Refer to FX3g Hardware Edition.
→ Refer to FX3u Hardware Edition.
→ Refer to FX3uc Hardware Edition.

1 Introduction

2 Specification

3 System Configuration

4 Installation

5 Wiring

6 Introduction of Functions

7 Alarm

8 Buffer Memory

9 Program Examples

10 Troubleshooting

23

Shows the reference.
The "→" mark indicates a reference destination and reference manual.

The above is different from the actual page, as it is provided for explanation only.

1. Introduction

1.1 Outline

The temperature control block FX3U-4LC (hereinafter called 4LC) equipped with 4 channel input (thermocouples, resistance thermometer and micro voltage input), 4 points output (open collector transistor) and 4 points CT input is a special function block for thermometer control.

1.1.1 Major features of the FX3U-4LC

The 4LC has the following features.

- 1) Allows inputs from 4 channels.
The 4LC supports temperature sensor inputs from thermocouples and resistance thermometers as well as micro voltage inputs.
- 2) Incorporates outputs from 4 channels.
The 4LC incorporates NPN open collector transistor outputs.
- 3) Performs heating/cooling PID control.
The 4LC handles two systems of outputs, heating output and cooling output, and performs heating/cooling control.
- 4) Performs cascade control.
The 4LC performs cascade control through combination of two control loops, the master loop and slave loop.
- 5) Performs control using external analog inputs/outputs.
The 4LC performs PID control using voltage/current inputs and voltage/current outputs when combined with a special function block for analog input/output.
- 6) Performs auto tuning.
The 4LC can automatically measure, calculate and set optimal PID constants for the preset temperature.
- 7) Performs startup tuning.
The 4LC can automatically calculate and set PID constants based on the response characteristics of the control target when control is started or when the set value (SV) is changed.
- 8) Detects heater disconnection.
The 4LC can detect heater disconnection using the current detector (CT).
- 9) Backs up set values using the EEPROM.
The 4LC can back up set values stored in buffer memories using the built-in EEPROM.
- 10) Connectable PLC
Connect the 4LC to the FX3G/FX3U/FX3UC Series PLC.
An FX2NC-CNV-IF or FX3UC-1PS-5V is necessary to connect the 4LC with the FX3UC PLC.

1.2 External Dimensions and Part Names

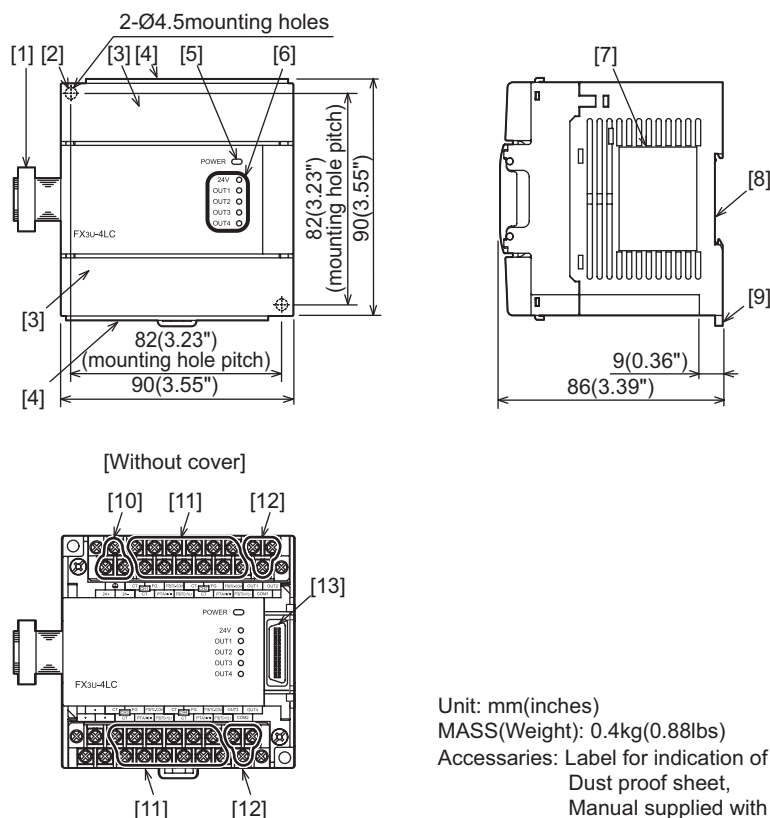

Unit: mm(inches)
 MASS(Weight): 0.4kg(0.88lbs)
 Accessories: Label for indication of special unit/block number,
 Dust proof sheet,
 Manual supplied with product

- | | |
|---|---|
| <ul style="list-style-type: none"> [1] Extension cable [2] Direct mounting hole
2 holes of ϕ 4.5 (0.18") (mounting screw: M4 screw) [3] Terminal block covers [4] Terminal cover [5] Power LED (green) [6] Status LEDs (red)
→ Refer to Section 1.4. [7] Nameplate | <ul style="list-style-type: none"> [8] DIN rail mounting groove
(DIN rail: DIN46277, 35mm (1.38") width) [9] DIN rail mounting hook [10] Power supply terminal block (M3 screw)
→ Refer to Section 1.3. [11] Input terminal block (M3 screw)
→ Refer to Section 1.3. [12] Output terminal block (M3 screw)
→ Refer to Section 1.3. [13] Extension connector |
|---|---|

1	Introduction
2	Specification
3	System Configuration
4	Installation
5	Wiring
6	Introduction of Functions
7	Alarm
8	Buffer Memory
9	Program Examples
10	Troubleshooting

1.3 Terminal Layout

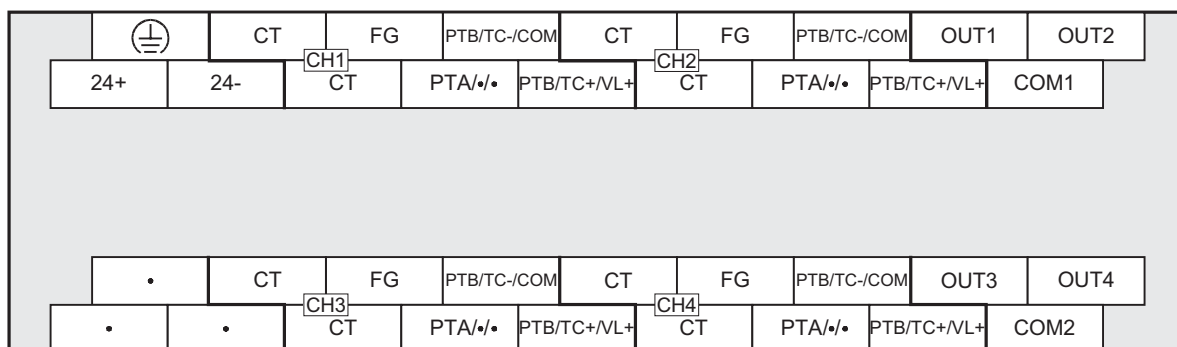

1.4 Power and Status LEDs

LED display	Color	Status	Description
POWER	Green	OFF	Power is not being supplied from the internal power supply (5V DC).
		ON	Power is being supplied from the internal power supply (5V DC).
24V	Red	OFF	Power is not being supplied from the external power supply (24V DC).
		ON	Power is being supplied from the external power supply (24V DC).
OUT1	Red	OFF	OUT1 output OFF
		ON	OUT1 output ON
OUT2	Red	OFF	OUT2 output OFF
		ON	OUT2 output ON
OUT3	Red	OFF	OUT3 output OFF
		ON	OUT3 output ON
OUT4	Red	OFF	OUT4 output OFF
		ON	OUT4 output ON

2. Specification

DESIGN PRECAUTIONS



DANGER

- Make sure to include the following safety circuits outside the PLC to ensure safe system operation even during external power supply problems or PLC failure.
Otherwise, malfunctions may cause serious accidents.
 - 1) Above all, the following components should be included: an emergency stop circuit, a protection circuit, an interlock circuit for opposite movements (such as normal vs. reverse rotation), and an interlock circuit (to prevent damage to the equipment at the upper and lower positioning limits).
 - 2) Note that when the PLC CPU detects an error, such as a watchdog timer error, during self-diagnosis, all outputs are turned off. Also, when an error that cannot be detected by the PLC CPU occurs in an input/output control block, output control may be disabled.
External circuits and mechanisms should be designed to ensure safe machinery operation in such a case.
 - 3) Note that when an error occurs in a relay, triac or transistor output device, the output could be held either on or off.
For output signals that may lead to serious accidents, external circuits and mechanisms should be designed to ensure safe machinery operation in such a case.

DESIGN PRECAUTIONS



CAUTION

- Do not bundle the control line together with or lay it close to the main circuit or power line. As a guideline, lay the control line at least 100mm (3.94") or more away from the main circuit or power line.
Noise may cause malfunctions.
- Ground the shield wire or shield of the shielded cable at one point on the PLC. However, do not ground them at the same point as the high-voltage lines.
Noise may cause malfunctions.
- Install module so that excessive force will not be applied to the terminal blocks.
Failure to do so may result in wire damage/breakage or PLC failure.

DISPOSAL PRECAUTIONS



CAUTION

- Please contact a certified electronic waste disposal company for the environmentally safe recycling and disposal of your device.

TRANSPORTATION PRECAUTIONS



CAUTION

- The PLC is a precision instrument. During transportation, avoid impacts larger than those specified in the general specifications of the PLC main unit manual.
Failure to do so may cause failures in the PLC.
After transportation, verify the operations of the PLC.

1

Introduction

2

Specification

3

System
Configuration

4

Installation

5

Wiring

6

Introduction of
Functions

7

Alarm

8

Buffer Memory

9

Program
Examples

10

Troubleshooting

2.1 General Specifications

For items not listed below, specifications are the same as the of the PLC main unit.
For general specifications, refer to the manual of the PLC main unit.

- Refer to FX3G Hardware Edition.
- Refer to FX3U Hardware Edition.
- Refer to FX3UC Hardware Edition.

Item	Specification	
Dielectric withstand voltage	500V AC for one minute	Between all terminals and ground terminal
Insulation resistance	5MΩ or more by 500V DC Megger	

2.2 Power Supply Specifications

Item	Specification
Interface driving power	24V DC +20% -15% 50mA Connect a 24V DC power supply to the terminal block.
CPU driving power	5V DC 160mA 5V DC power is supplied internally from the main unit.

2.3 Performance Specifications

Item	Specification
Control method	Two-position control PID control Heating/cooling PID control Cascade control
Control operation period	250ms/4ch
Set temperature range	Equivalent to input range (Refer to Subsection 8.2.52.)
Heater disconnection detection	Alarm is detected by buffer memory (Variable within range from 0.0 to 100.0A.)
Operation mode	0 : Not used 1 : Monitor 2 : Monitor + Alarm 3 : Monitor + Alarm + Control (Selected by buffer memory)
Self-diagnosis function	Adjustment data check, input value check, watch dog timer check. When abnormality is detected, transistor output turns OFF.
Memory	Built-in EEPROM (Number of times of overwrite : 100,000 times)
Insulation method	<ul style="list-style-type: none"> • The photocoupler is used to insulate the analog input area from the PLC. • The DC/DC converter is used to insulate the power supply from the analog inputs. • Channels are insulated from each other.
Number of I/O occupied points	8 points (Taken from either the input or output points of the PLC.)

2.4 Input Specifications

2.4.1 Temperature input specifications

Item	Specification	
Number of input points	4 points	
Input type *1	Thermocouple	K, J, R, S, E, T, B, N JIS C 1602-1995 PLII, W5Re/W26Re, U, L
	Resistance thermometer	3-wire Pt100 JIS C 1604-1997 3-wire JPt100 JIS C 1604-1981 2-wire or 3-wire Pt1000 JIS C 1604-1997
	Micro voltage input	
Measurement precision	When ambient temperature is 25°C±5 °C	Measurement accuracy differs depending on the type of input, and the input range. For specification details, refer to Subsection 2.4.2.
	When ambient temperature is 0 to 55°C	Measurement accuracy differs depending on the type of input, and the input range. For specification details, refer to Subsection 2.4.2.
Cold contact temperature compensation error	Within ±1.0 °C (When ambient temperature is 0 to 55°C) However, within ± 2.0 °C while input value is -150 to -100 °C / within ± 3.0 °C while input value is -200 to -150 °C	
Resolution	0.1°C (0.1°F), 1°C (1°F), 0.5μV or 5.0μV Varies depending on input range of used sensors.	
Sampling period	250ms/4ch	
Effect of external resistance (When thermocouple is used)	Approx.0.125μV/Ω	
Effect of input lead wire resistance (When resistance thermometer is used)	3-wire type	Approx. 0.03%/Ω of full scale. 10Ω or less per 1-wire
	2-wire type	Approx. 0.04%/Ω of full scale. 7.5Ω or less per 1-wire
Input impedance	1MΩ or more	
Sensor current	Approx.0.25mA (When resistance thermometer is used)	
Operation when input is disconnected	Upscale	
Operation when input is short-circuited	Downscale (When resistance thermometer is used)	

*1. A different input can be selected for each channel.

1

Introduction

2

Specification

3

System Configuration

4

Installation

5

Wiring

6

Introduction of Functions

7

Alarm

8

Buffer Memory

9

Program Examples

10

Troubleshooting

2.4.2 Measurement precision

The measurement precision is as shown below. The measurement precision of the thermocouple does not include the cold contact temperature compensation error. For the cold contact temperature compensation error, refer to Subsection 2.4.1.

Digits below the minimum resolution (shown in the measurement precision below) of the input value are rounded up.

1. When ambient temperature is 25°C±5°C

Input type	Input range	Measurement precision
K, J, E, T, PLII, U, L	Less than -100°C	±3.0°C±1digit
	-100°C to less than 500°C	±1.5°C±1digit
	500°C or more	±(0.3% of input value)±1digit
R, S, N, W5Re/W26Re	Less than 1000°C	±3.0°C±1digit
	1000°C or more	±(0.3% of input value)±1digit
B	Less than 400°C	±70°C±1digit
	400°C to less than 1000°C	±3°C±1digit
	1000°C or more	±(0.3% of input value)±1digit
Pt100, JPt100, Pt1000	Less than 200°C	±0.6°C±1digit
	200°C or more	±(0.3% of input value)±1digit
Micro voltage input	-	±(0.3% of span)±1digit

2. When ambient temperature is 0 to 55°C

Input type	Input range	Measurement precision
K, J, E, T, PLII, U, L	Less than -100°C	±7.0°C±1digit
	-100°C to less than 500°C	±3.5°C±1digit
	500°C or more	±(0.7% of input value)±1digit
R, S, N, W5Re/W26Re	Less than 1000°C	±3.0°C±1digit
	1000°C or more	±(0.7% of input value)±1digit
B	Less than 400°C	±140°C±1digit
	400°C to less than 1000°C	±7°C±1digit
	1000°C or more	±(0.7% of input value)±1digit
Pt100, JPt100, Pt1000	Less than 200°C	±1.4°C±1digit
	200°C or more	±(0.7% of input value)±1digit
Micro voltage input	-	±(0.7% of span)±1digit

2.4.3 Current detector (CT) input specifications

Item	Specification	
Number of input points	4 points	
Current detector	CTL-12-S36-8, CTL-12-S56-10, CTL-6-P-H (manufactured by U.R.D. Co., Ltd.)	
Heater current measured value	When CTL-12-S36-8 is used	0.0 to 100.0A
	When CTL-12-S56-10 is used	0.0 to 100.0A
	When CTL-6-P-H is used	0.0 to 30.0A
Measurement precision	Larger one between ±5% of input value and ±2A (Excluding precision of current detector)	
Sampling period	0.5 sec.	

2.5 Input Type

Input type	K	J	R	S
Input range	-200.0 to 200.0°C -100.0 to 400.0°C -100 to 1300°C -100 to 800°F -100 to 2400°F	-200.0 to 200.0°C -100.0 to 400.0°C -100.0 to 800.0°C -100 to 1200°C -100 to 1600°F -100 to 2100°F	0 to 1700°C 0 to 3200°F	0 to 1700°C 0 to 3200°F
Input type	E	T	B	N
Input range	-200.0 to 200.0°C 0 to 1000°C 0 to 1800°F	-200.0 to 200.0°C -200.0 to 400.0°C 0.0 to 400.0°C -300.0 to 400.0°F -300.0 to 700.0°F 0 to 700.0°F	0 to 1800°C 0 to 3000°F	0 to 1300°C 0 to 2300°F
Input type	PLII	W5Re/W26Re	U	L
Input range	0 to 1200°C 0 to 2300°F	0 to 2300°C 0 to 3000°F	-200.0 to 600.0°C -300.0 to 700.0°F	0.0 to 900.0°C 0 to 1600°F
Input type	Pt100	JPt100	Pt1000	Micro voltage input
Input range	-50.0 to 150.0°C -200.0 to 600.0°C -300.0 to 300.0°F -300 to 1100°F	-50.0 to 150.0°C -200.0 to 500.0°C -300.0 to 300.0°F -300 to 900°F	-200.0 to 650.0°C -328 to 1184°F	0 to 10mV 0 to 100mV

2.6 Output Specifications

Item	Specification
Number of output points	4 points
Output method	NPN open collector transistor output
Rated load voltage	5 to 24V DC
Maximum load voltage	30V DC or less
Maximum load current	100mA
Leak current in OFF status	0.1mA or less
ON voltage	1.5V (When the maximum load current)
Control output cycle	0.5 to 100.0 sec.

1

Introduction

2

Specification

3

System Configuration

4

Installation

5

Wiring

6

Introduction of Functions

7

Alarm

8

Buffer Memory

9

Program Examples

10

Troubleshooting

3. System Configuration

3.1 General Configuration

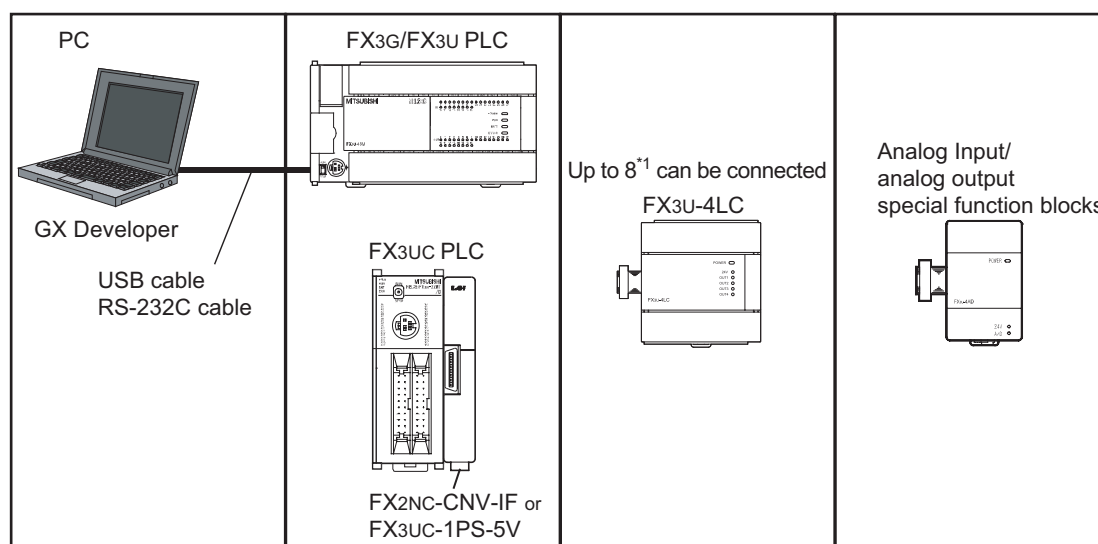

*1. For the maximum number, refer to Section 3.2.

Component list

Part name	Model name	Remarks
Temperature control block	FX3U-4LC	An FX2NC-CNV-IF or FX3UC-1PS-5V is necessary to connect the 4LC with the FX3UC PLC.
PLC	FX3G/FX3U/FX3UC PLC	-
The special function block for an analog input/output	FX3U-4AD,FX3U-4DA etc.	Special function block used for control using external inputs/ outputs. For connectable equipment, refer to the following manual corresponding to the connected PLC. → Refer to FX3G Hardware Edition. → Refer to FX3U Hardware Edition. → Refer to FX3uc Hardware Edition.
PC software	GX Developer	PLC programming software
PC	-	-
USB cable	FX-USB-AW	Cable with RS-422/USB converter between a FX PLC and PC.
RS-232C cable	F2-232CAB-1	PC connection cable and interface
	FX-232AWC-H	
	FX-422CAB0	

3.2 Applicable PLC

Model name	Applicability
FX3G Series PLC	Ver. 1.00 and later (Up to 8 blocks can be connected)
FX3U Series PLC	Ver. 2.20 and later (Up to 8 blocks can be connected)
FX3UC Series PLC*1	Ver. 2.20 and later (Up to 8 blocks can be connected*2)

The version number can be checked by reading the last three digits of device D8001.

- *1. An FX2NC-CNV-IF or FX3UC-1PS-5V is necessary to connect the 4LC with the FX3UC PLC.
- *2. Up to 7 units can be connected to the FX3UC-32MT-LT(-2) PLC.

3.3 Connection with PLC

The 4LC connects with a PLC via an extension cable.

The 4LC is handled as a special extension block of the PLC. The unit number of the 4LC is automatically assigned No.0 to No.7 (Unit No.1 to No.7 is assigned when the main unit is an FX3UC-32MT-LT(-2).) starting from the special function unit/block closest to the PLC main unit.

(This unit number is used for the designation of a FROM/TO instruction.)

For details on the assignment of the I/O number and unit number of the PLC, refer to the following manual corresponding to the connected PLC.

- Refer to FX3G Hardware Edition.
- Refer to FX3U Hardware Edition.
- Refer to FX3UC Hardware Edition.

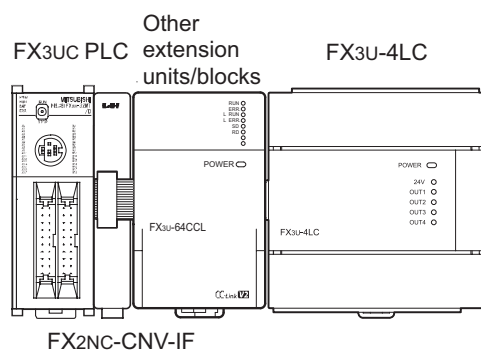
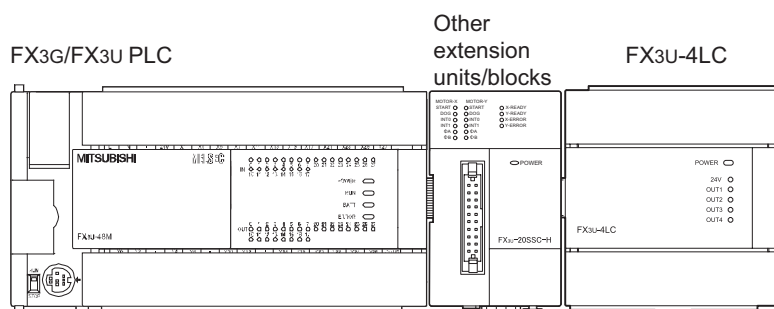

- An FX2NC-CNV-IF or FX3UC-1PS-5V is necessary to connect the 4LC with the FX3UC PLC.
- The number of I/O points occupied by the 4LC is eight. Make sure that the total number of I/O points (occupied I/O points) of the main unit, extension unit(s), extension block(s) and the number of points occupied by special function blocks does not exceed the maximum number of I/O points of the PLC. For information on the maximum number of I/O points of the PLC, refer to the respective product manual.
 - Refer to FX3G Hardware Edition.
 - Refer to FX3U Hardware Edition.
 - Refer to FX3UC Hardware Edition.

4. Installation

INSTALLATION PRECAUTIONS



DANGER

- Make sure to shut down all phases of the power supply externally before installing. Failure to do so may cause electric shock or damage to the product.

INSTALLATION PRECAUTIONS



CAUTION

- Use the product within the generic environment specifications described in PLC main unit manual (Hardware Edition). Never use the product in areas with excessive dust, oily smoke, conductive dusts, corrosive gas (salt air, Cl₂, H₂S, SO₂, or NO₂), flammable gas, vibration or impacts, or expose it to high temperature, condensation, or rain and wind. If the product is used in such conditions, electric shock, fire, malfunctions, deterioration or damage may occur.
- Do not touch the conductive parts of the product directly. Doing so may cause device failures or malfunctions.
- Install the product securely using a DIN rail or mounting screws.
- Install the product on a flat surface.
- If the mounting surface is rough, undue force will be applied to the PC board, thereby causing nonconformities.
- When drilling screw holes or wiring, make sure that cutting and wiring debris do not enter the ventilation slits. Failure to do so may cause fire, equipment failures or malfunctions.
- Be sure to remove the dust proof sheet from the PLC's ventilation port when installation work is completed. Failure to do so may cause fire, equipment failures or malfunctions.
- Connect extension cables securely to their designated connectors. Loose connections may cause malfunctions.
- Turn off the power to the PLC before attaching or detaching the following devices. Failure to do so may cause device failures or malfunctions.
 - Peripheral devices, display modules, expansion boards and special adapters
 - I/O extension units/blocks, FX Series terminal block and the special function units/blocks
 - Battery and memory cassette

The 4LC unit can be connected to the right side of the main unit, extension unit or extension block.

To connect to an FX3UC PLC or FX2NC PLC extension block, the FX2NC-CNV-IF or FX3UC-1PS-5V is necessary.

For details, refer to the respective PLC manual.

→ Refer to the FX3G Hardware Edition.

→ Refer to the FX3U Hardware Edition.

→ Refer to the FX3UC Hardware Edition.

The 4LC may be installed in a control cabinet with a 35mm wide DIN46277 DIN rail mounting or M4 screw direct mounting.

Cautions in examining installing method

When the system is laid out in two stages, do not mount 4LC at the top of the second stage, or FX2N-CNV-BC cannot be installed directly.

4.1 DIN rail Mounting

The product may be mounted on a 35mm wide DIN46277 (DIN rail).

- 1 **Fit the upper edge (A in the figure to the right) of the DIN rail mounting groove onto the DIN rail.**
- 2 **Push the product onto the DIN rail.**
 - An interval space of 1 to 2mm (0.04" to 0.08") between each unit is necessary.
- 3 **Connect the extension cable.**

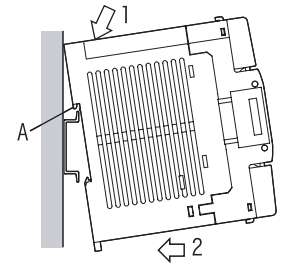

Connect the extension cable (B in the figure to the right) to the main unit, I/O extension unit/block or special function unit/block on the left side of the product.

For information on the extension cable connection procedure, refer to the respective product PLC manual.

- Refer to the FX3G Hardware Edition.
- Refer to the FX3U Hardware Edition.
- Refer to the FX3uc Hardware Edition.

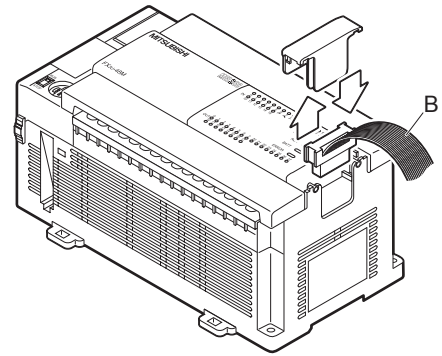

- Example of installation on DIN rail
 - In the case of the FX3G/FX3U PLC

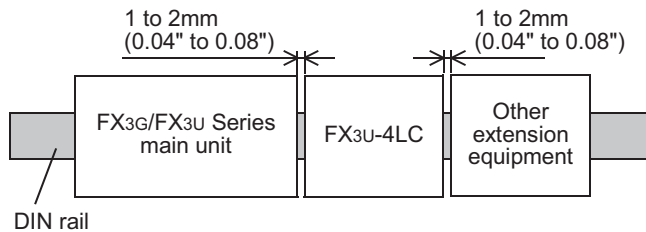

- In the case of the FX3UC PLC

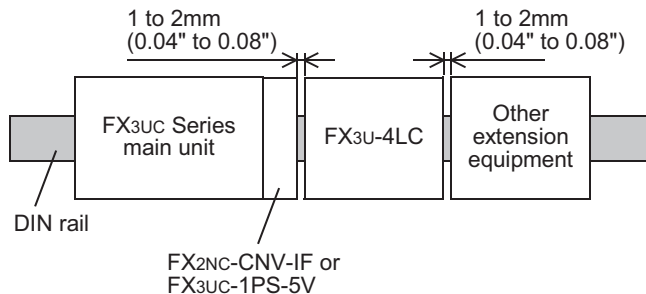

1	Introduction
2	Specification
3	System Configuration
4	Installation
5	Wiring
6	Introduction of Functions
7	Alarm
8	Buffer Memory
9	Program Examples
10	Troubleshooting

4.2 Direct Mounting

The product can be installed directly with screws.
An interval space of 1 to 2mm (0.04" to 0.08") between each unit is necessary.
For installation details, refer to the following respective PLC manual.

- For mounting hole pitches, refer to Section 1.2.
- Refer to the FX3G Hardware Edition.
- Refer to the FX3U Hardware Edition.
- Refer to the FX3UC Hardware Edition.

1 Create mounting holes in the mounting surface according to the external dimensions diagram.

2 Fit the 4LC (A in the figure to the right) to the mounting holes and tighten with M4 screws (B in the figure to the right).

For the screw position and quantity, refer to the dimensioned drawing specified below.
→ For dimensions, refer to Section 1.2.

3 Connect the extension cable.

Connect the extension cable to the main unit, I/O extension unit/block or special function unit/block on the left side of the product.
(Refer to Step 3 in Section 4.1.)
For information on the extension cable connection procedure, refer to the respective PLC manual.
→ Refer to the FX3G Hardware Edition.
→ Refer to the FX3U Hardware Edition.
→ Refer to the FX3UC Hardware Edition.

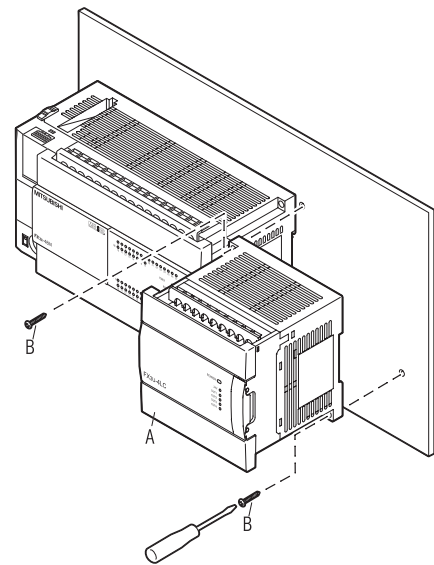

- Example of direct installation

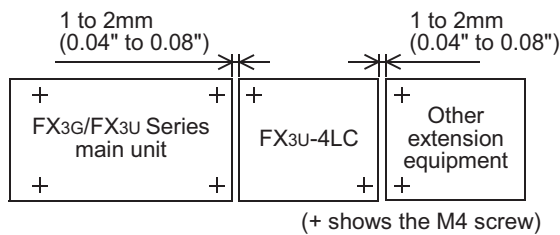

5. Wiring

WIRING PRECAUTIONS



DANGER

- Make sure to cut off all phases of the power supply externally before attempting wiring work. Failure to do so may cause electric shock.

WIRING PRECAUTIONS



CAUTION

- Connect the AC power supply to the dedicated terminals specified in this manual. If an AC power supply is connected to a DC input/output terminal or DC power supply terminal, the PLC will burn out.
- Do not wire vacant terminals externally. Doing so may damage the product.
- Use class D grounding (grounding resistance of 100Ω or less) with a wire of 2mm² or thicker on the grounding terminal of the PLC. However, do not connect the ground terminal at the same point as a heavy electrical system.
- When drilling screw holes or wiring, make sure cutting or wire debris does not enter the ventilation slits. Failure to do so may cause fire, equipment failures or malfunctions.
- Make sure to observe the following precautions in order to prevent malfunctions under the influence of noise.
 - Do not bundle the power line or twisted shielded cable together with or lay it close to the main circuit, high-voltage line, or load line. Otherwise, noise disturbance and/or surge induction are likely to take place. As a guideline, lay the control line at least 100mm (3.94") or more away from the main circuit, high-voltage line, or load line.
 - Ground the shield wire or shield of the shielded cable at one point on the PLC. However, do not use common grounding with heavy electrical systems.
- Make sure to properly wire to the terminal blocks in accordance with the following precautions. Failure to do so may cause electric shock, equipment failures, a short-circuit, wire breakage, malfunctions, or damage to the product.
 - The disposal size of the cable end should follow the dimensions described in the manual.
 - Tightening torque should follow the specifications in the manual.

1

Introduction

2

Specification

3

System Configuration

4

Installation

5

Wiring

6

Introduction of Functions

7

Alarm

8

Buffer Memory

9

Program Examples

10

Troubleshooting

5.1 Power Supply Wiring

5.1.1 Power supply wiring

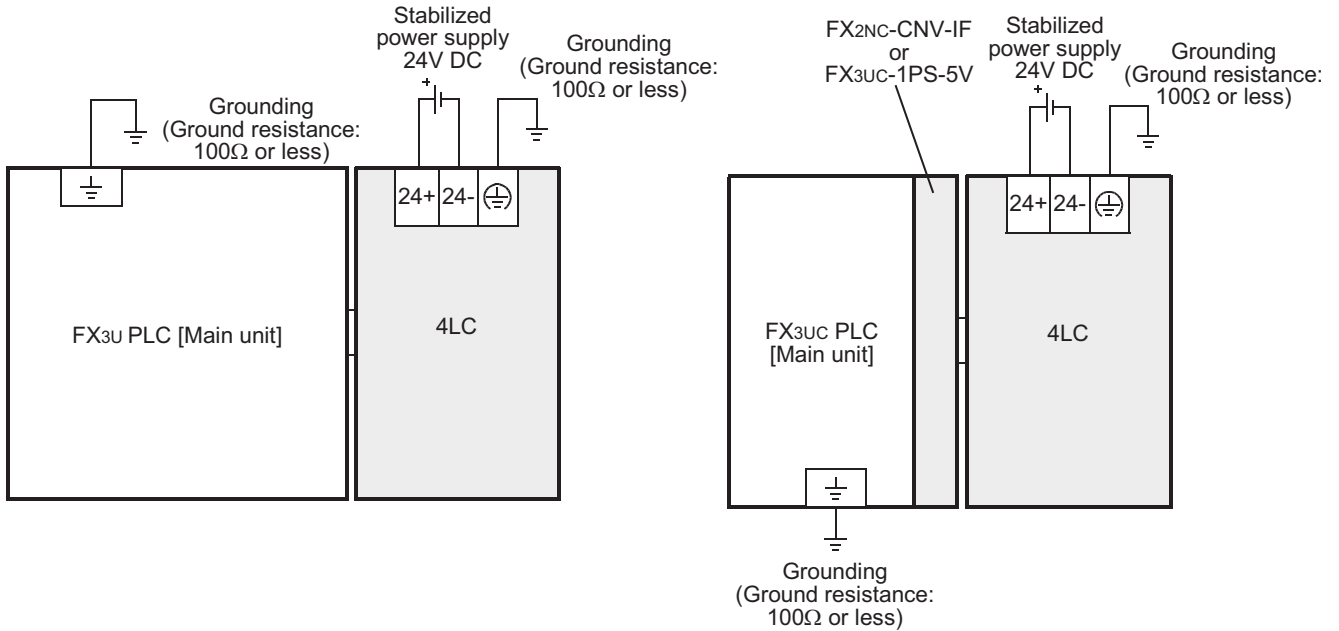

Power-on/off timing

The 4LC power supply should be turned ON simultaneously with or before the power supply of the PLC main unit. Before turning the power OFF, ensure the safety of the system and then simultaneously turn the main unit, 4LC, and other extension equipment (the special extension equipment is included) OFF. For details, refer to the respective PLC manual.

- Refer to the FX3G Hardware Edition.
- Refer to the FX3U Hardware Edition.
- Refer to the FX3UC Hardware Edition.

5.1.2 Grounding

Ground the cables as follows

- The grounding resistance should be 100Ω or less.
- Independent grounding should be established whenever possible. Independent grounding should be performed for best results. When independent grounding is not configured, perform "shared grounding" as shown in the following figure. For details, refer to the respective PLC manual.

- Refer to the FX3G Hardware Edition.
- Refer to the FX3U Hardware Edition.
- Refer to the FX3UC Hardware Edition.

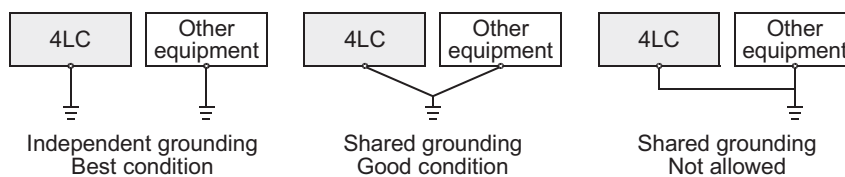

- The grounding point should be close to the 4LC, and all grounding wires should be as short as possible.

5.2 Input Wiring

5.2.1 Wiring example of thermocouple

For thermocouples applicable to the 4LC, refer to the following.

→ Refer to the Section 2.4.

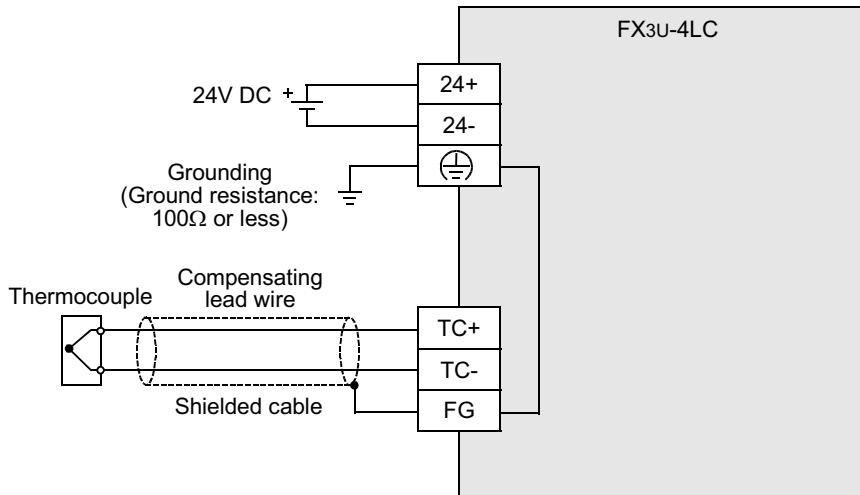

Caution

When using a thermocouple, use specified compensating lead wires.

5.2.2 Wiring example of resistance thermometer

For resistance thermometers applicable to the 4LC, refer to the following.

→ Refer to the Section 2.4.

- When used the Pt100 (3-wire) or Pt1000 (3-wire)

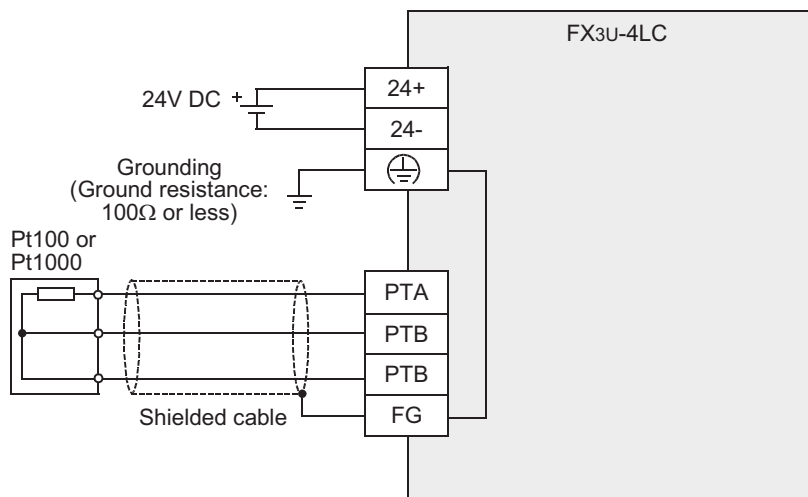

Caution

When you use a resistance temperature sensor, the resistance of the leadwire is low, use a wire without a resistance difference between the leadwire.

1	Introduction
2	Specification
3	System Configuration
4	Installation
5	Wiring
6	Introduction of Functions
7	Alarm
8	Buffer Memory
9	Program Examples
10	Troubleshooting

- When used the Pt1000 (2-wire)

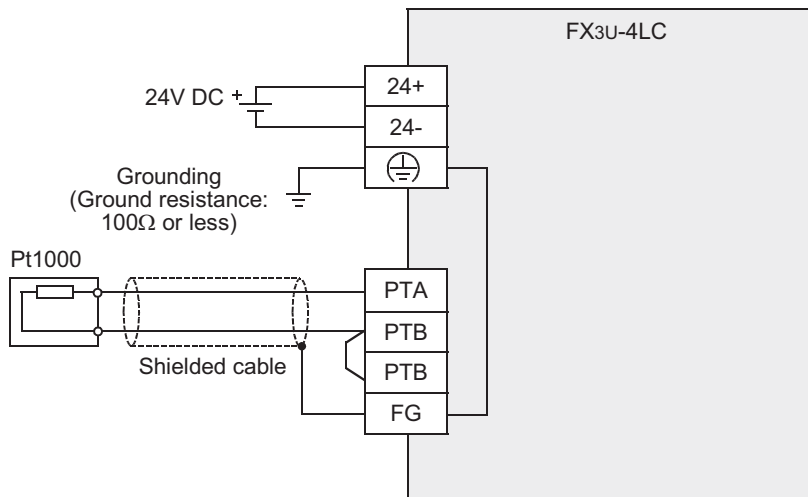

Caution

- When you use a resistance temperature sensor, the resistance of the leadwire is low, use a wire without a resistance difference between the leadwire.
- Make sure to short-circuit the 'PTB' and 'PTB' terminals when 2-wire of a resistance thermometer sensor is input.

5.2.3 Wiring example of micro voltage input

For the input range of micro voltage inputs applicable to the 4LC, refer to the following.

→ Refer to the Section 2.5.

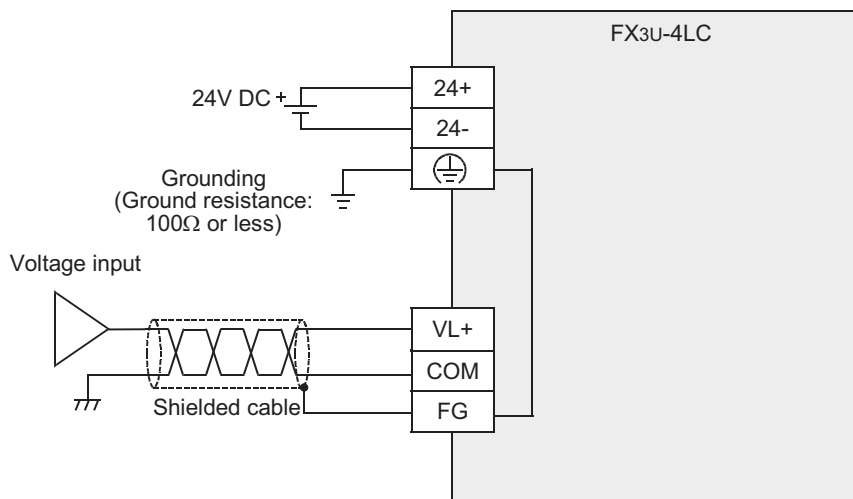

5.3 Output Wiring

The 4LC incorporates NPN open collector transistor outputs.
For the output specifications, refer to the following.

→ Refer to the Section 2.6.

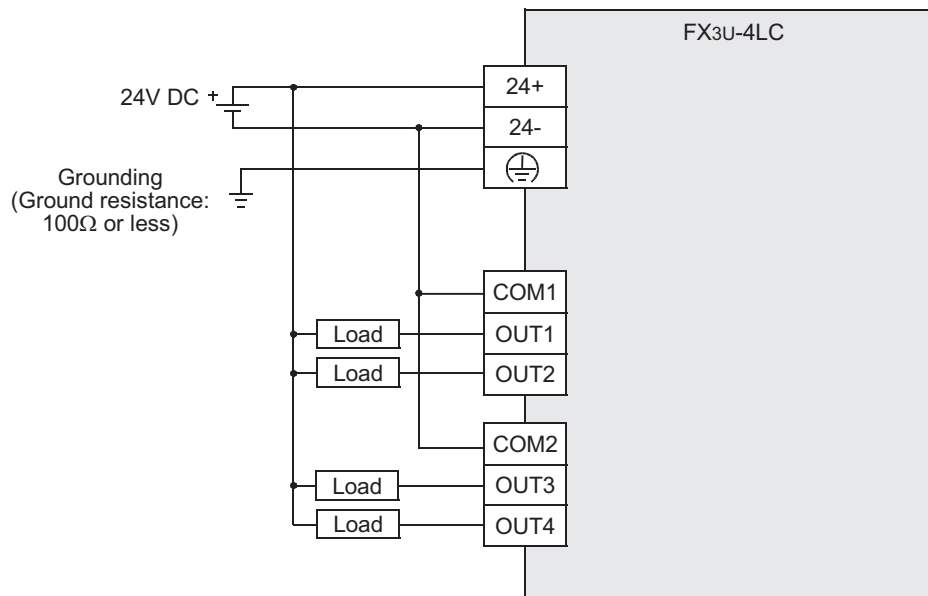

1	Introduction
2	Specification
3	System Configuration
4	Installation
5	Wiring
6	Introduction of Functions
7	Alarm
8	Buffer Memory
9	Program Examples
10	Troubleshooting

5.4 Terminal Screw and Tightening Torque

The terminals on the 4LC use M3 screws.
Refer to the figures below for cable end treatment.
Tighten the terminals to a torque of 0.5 to 0.8 N·m.
Do not tighten terminal screws with a torque exceeding the regulation torque. Failure to do so may cause equipment failures or malfunctions.

- When one wire is connected to one terminal

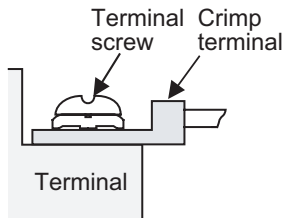
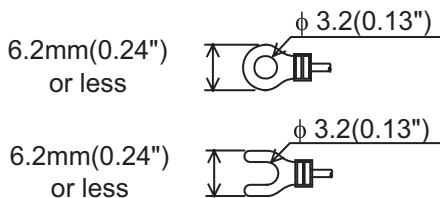

- When two wires are connected to one terminal

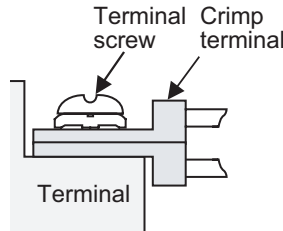
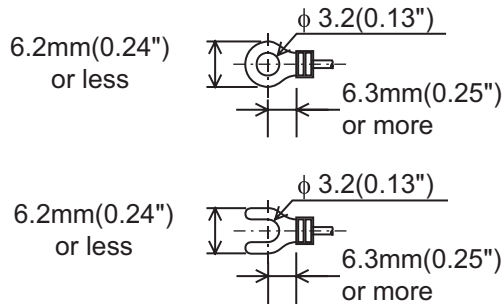

6. Introduction of Functions

6.1 Functions List

The list below describes functions of the 4LC.

Functions	Description	Reference
Control mode switch function	Selects the control type and used input/output for each control group.	Section 6.2
Transistor output selection function	Selects the function of transistor outputs built into the 4LC.	Section 6.3
PID control	Offers stable control results by presetting constants, P (proportional band), I (integral time) and D (derivative time).	Section 6.4
Overshoot prevention function	Prevents overshoot of the control output (MV).	Subsection 6.4.2
Two-position control	Turns ON or OFF the control output (MV) depending on whether the measured value (PV) is larger or smaller than the set value (SV).	Section 6.5
Heating/cooling PID control	Handles two systems of outputs, heating control output and cooling control output.	Section 6.6
Overlap/Dead band function	Switches the significant point between control stability and energy saving by shifting the temperature at which cooling control is started.	Subsection 6.6.3
Cooling method	Switches the cooling method (among "air cooling type", "water cooling type" and "cooling gain linear type") in accordance with the cooling unit type.	Subsection 6.6.4
Cascade control	Performs cascade control by combining two control loops, the master loop and slave loop.	Section 6.7
SV tracking selection function	Makes the slave channel set value (SV) track the set value (value stored in the set value monitor buffer memory) just before changeover to cascade OFF when the cascade control function is changed from ON to OFF.	Subsection 6.7.3
Auto tuning function	Automatically measures, calculates and sets optimal PID constants for the preset temperature.	Section 6.8
AT (Auto tuning) bias	Changes the auto tuning set value (SV). Set to prevent the measured value (PV) from exceeding the set value (SV) when performing auto tuning.	Subsection 6.8.2
Startup tuning function	Automatically calculates and sets PID constants based on the response characteristics of the control target when control is started or when the set value (SV) is changed.	Section 6.9
AUTO mode/MANUAL mode	Switches the mode between the AUTO mode (in which the control output value (MV) is automatically calculated based on the set value (SV)) and the MANUAL mode (in which the control output value (MV) is set arbitrarily and manually).	Section 6.10
Balance-less, bump-less function	Prevents overload caused by drastic change in the control output (MV) when the mode is changed over between the AUTO mode and the MANUAL mode.	Subsection 6.10.2
Heater disconnection alarm function	Detects the current flowing using the current detector (CT), and detects heater disconnection.	Section 6.11
Number of times of heater disconnection alarm delay	Sets the continuous number of times of detecting a heater disconnection or detecting abnormal current while the output is OFF to be judged as an alarm.	Subsection 6.11.2
Loop breaking alarm function	Detects abnormalities in the control target, input sensors, etc.	Section 6.12
Loop breaking alarm dead zone	Sets the area to be excluded from the loop breaking alarm status.	Subsection 6.12.2

1

Introduction

2

Specification

3

System Configuration

4

Installation

5

Wiring

6

Introduction of Functions

7

Alarm

8

Buffer Memory

9

Program Examples

10

Troubleshooting

6.2 Control Mode Switch Function

The control mode switch function sets the control type (PID control, two-position control, manual control, cascade control or heating/cooling control) and used input/output (external or internal) for each control group. Make sure to set the control mode before performing control.

Up to 4 loops are available for each control type. However, only up to 2 loops are available for cascade control.

Control groups are classified into the group 1 (CH1 and CH2) and group 2 (CH3 and CH4).

Control mode

Control mode	Control type	Input	Output
0	PID control	Internal	Internal
1		External	
2	Manual control Cascade control	Internal	External
3		External	
4	Heating/cooling PID control	Internal	Internal
5		External	
6	Two-position control	Internal	External
7		External	

- When internal input is selected
The 4LC performs control using measured values detected through inputs built into the 4LC.
- When external input is selected
The 4LC performs control using values stored in external input value buffer memories (BFM#25 to BFM#28) without using inputs built into the 4LC.
- When internal output is selected
The 4LC performs control using transistor outputs built into the 4LC. However, in heating/cooling PID control, the control output of CH2 and CH4 should use an external output.
- When external output is selected
The 4LC performs control using values stored in external output value monitor/heating external output value monitor buffer memories (BFM#32 to BFM#35) and cooling external output value monitor buffer memories (BFM#36 to BFM#39) without using transistor outputs built into the 4LC. The transistor output built into the 4LC is controllable when transistor output selections 1 and 2 are chosen. Additionally the outputs can also be used as alarm outputs.
 - For details on the external input value, refer to Subsection 8.2.8.
 - For details on the external output value, refer to Subsection 8.2.11 or 8.2.12.
 - For details on the transistor output selection, refer to Subsection 8.2.50.

Point

When external input is selected, the following results are given.

- Input range setting
 - The input span is "external input range upper limit"- "external input range lower limit".
 - The input range is from "external input range lower limit" to "external input range upper limit".
- Setting limiter
 - The setting range of the setting limiter upper limit is from "setting limiter lower limit +1" to "external input range upper limit".
 - The setting range of the setting limiter lower limit is from "external input range lower limit" to "setting limiter upper limit -1".
- Set value (SV)
 - The set value range is from "setting limiter lower limit" to "setting limiter upper limit".
- Input error
 - When a value equivalent to or larger than "external input range upper limit +5%/input span" is set to the external input value, it is regarded as an input error (upper limit), and b0 of the event buffer memory for the corresponding channel turns ON.
 - When a value equivalent to or smaller than "external input range lower limit -5%/input span" is set to the external input value, it is regarded as an input error (lower limit), and b1 of the event buffer memory for the corresponding channel turns ON.

When external output is selected, the following results are given

- External output value/heating external output value and cooling external output value
 - The control output value is written to the external output value/heating external output value and cooling external output value, and the scaled value is written to the range from "external output range lower limit" to "external output range upper limit" without regard to the setting of the control mode switch function.

Associated buffer memory

BFM No.				Description	Reference
CH1	CH2	CH3	CH4		
#1	#2	#3	#4	Event (b0 : Input error (upper limit)) (b1 : Input error (lower limit))	Subsection 8.2.2
#5	#6	#7	#8	Measured value (PV)	Subsection 8.2.3
#25	#26	#27	#28	External input value	Subsection 8.2.8
#32	#33	#34	#35	External output value/Heating external output value monitor	Subsection 8.2.11
#36	#37	#38	#39	Cooling external output value monitor	Subsection 8.2.12
#44	#45	#46	#47	Control mode monitor	Subsection 8.2.14
#48	#88	#128	#168	Set value (SV)	Subsection 8.2.15
#76	#116	#156	#196	Setting limiter upper limit	Subsection 8.2.40
#77	#117	#157	#197	Setting limiter lower limit	Subsection 8.2.41
#82	#122	#162	#202	External input range upper limit	Subsection 8.2.46
#83	#123	#163	#203	External input range lower limit	Subsection 8.2.47
#84	#124	#164	#204	External output range upper limit	Subsection 8.2.48
#85	#125	#165	#205	External output range lower limit	Subsection 8.2.49
#86	#126	#166	#206	Transistor output selection	Subsection 8.2.50
#240		#241		Control mode switch	Subsection 8.2.62

Caution

It is not possible to change the control mode while control is being performed. If the control mode is changed while control is being performed, the contents of setting are changed when control is stopped.

6.3 Transistor Output Selection Function

The transistor output selection function selects either one among control output, alarm output and loop breaking alarm output for transistor outputs built into the 4LC.

For example, when external outputs are used for control, transistor outputs built into the 4LC are not required, and can be used as alarm outputs.

The transistor output selection function varies depending on the control mode setting as shown below. Set the transistor output for each channel.

→ For details on the control mode switch, refer to Section 6.2.

Transistor output selection

Transistor output selection set value	Control mode [BFM#240 (CH1, CH2), BFM#241 (CH3, CH4)]				
	0, 1 : PID control (Internal output)	2, 3 : PID control (External output)	4, 5 : Heating/cooling PID control (Internal output)*1	6, 7 : Heating/cooling PID control (External output)	
0	OUT1	CH1 control output	Normally OFF	CH1 heating control output	Normally OFF
	OUT2	CH2 control output	Normally OFF	CH1 cooling control output	Normally OFF
	OUT3	CH3 control output	Normally OFF	CH3 heating control output	Normally OFF
	OUT4	CH4 control output	Normally OFF	CH3 cooling control output	Normally OFF
1	OUT1	CH1 control output	CH1 control output	CH1 heating control output	CH1 heating control output
	OUT2	CH2 control output	CH2 control output	CH1 cooling control output	CH2 heating control output
	OUT3	CH3 control output	CH3 control output	CH3 heating control output	CH3 heating control output
	OUT4	CH4 control output	CH4 control output	CH3 cooling control output	CH4 heating control output
2	OUT1	CH1 control output	CH1 control output	CH1 heating control output	CH1 cooling control output
	OUT2	CH2 control output	CH2 control output	CH1 cooling control output	CH2 cooling control output
	OUT3	CH3 control output	CH3 control output	CH3 heating control output	CH3 cooling control output
	OUT4	CH4 control output	CH4 control output	CH3 cooling control output	CH4 cooling control output
3	OUT1	CH1 control output	CH1 alarm 1 state	CH1 heating control output	CH1 alarm 1 state
	OUT2	CH2 control output	CH2 alarm 1 state	CH1 cooling control output	CH2 alarm 1 state
	OUT3	CH3 control output	CH3 alarm 1 state	CH3 heating control output	CH3 alarm 1 state
	OUT4	CH4 control output	CH4 alarm 1 state	CH3 cooling control output	CH4 alarm 1 state
4	OUT1	CH1 control output	CH1 alarm 2 state	CH1 heating control output	CH1 alarm 2 state
	OUT2	CH2 control output	CH2 alarm 2 state	CH1 cooling control output	CH2 alarm 2 state
	OUT3	CH3 control output	CH3 alarm 2 state	CH3 heating control output	CH3 alarm 2 state
	OUT4	CH4 control output	CH4 alarm 2 state	CH3 cooling control output	CH4 alarm 2 state
5	OUT1	CH1 control output	CH1 alarm 3 state	CH1 heating control output	CH1 alarm 3 state
	OUT2	CH2 control output	CH2 alarm 3 state	CH1 cooling control output	CH2 alarm 3 state
	OUT3	CH3 control output	CH3 alarm 3 state	CH3 heating control output	CH3 alarm 3 state
	OUT4	CH4 control output	CH4 alarm 3 state	CH3 cooling control output	CH4 alarm 3 state
6	OUT1	CH1 control output	CH1 alarm 4 state	CH1 heating control output	CH1 alarm 4 state
	OUT2	CH2 control output	CH2 alarm 4 state	CH1 cooling control output	CH2 alarm 4 state
	OUT3	CH3 control output	CH3 alarm 4 state	CH3 heating control output	CH3 alarm 4 state
	OUT4	CH4 control output	CH4 alarm 4 state	CH3 cooling control output	CH4 alarm 4 state
7	OUT1	CH1 control output	CH1 loop breaking alarm state	CH1 heating control output	Normally OFF
	OUT2	CH2 control output	CH2 loop breaking alarm state	CH1 cooling control output	Normally OFF
	OUT3	CH3 control output	CH3 loop breaking alarm state	CH3 heating control output	Normally OFF
	OUT4	CH4 control output	CH4 loop breaking alarm state	CH3 cooling control output	Normally OFF

*1. When selecting control mode "4" or "5", use external output for CH2 and CH4.

Caution

It is not possible to change the setting while control is being performed. If the setting is changed while control is being performed, the contents of setting are reflected when control is stopped.

Associated buffer memory

BFM No.				Description	Reference
CH1	CH2	CH3	CH4		
#1	#2	#3	#4	Event (b4 to b7 Alarm 1 to Alarm 4) (b8 Loop breaking alarm)	Subsection 8.2.2
#9	#10	#11	#12	Control output value (MV) monitor/ Heating control output value (MV) monitor	Subsection 8.2.4
#13	#14	#15	#16	Cooling control output value (MV) monitor	Subsection 8.2.5
#17	#18	#19	#20	Control output flag	Subsection 8.2.6
#86	#126	#166	#206	Transistor output selection	Subsection 8.2.50
#240		#241		Control mode switch	Subsection 8.2.62

1	Introduction
2	Specification
3	System Configuration
4	Installation
5	Wiring
6	Introduction of Functions
7	Alarm
8	Buffer Memory
9	Program Examples
10	Troubleshooting

6.4 PID control

6.4.1 Easy PID control with two degrees of freedom

PID control is a control method to obtain stable control result by setting each of the constants "P (proportional band)", "I (integral time)" and "D (derivative time)".

However, if each PID constant is so set that the "response to setting" becomes good, the "response to disturbance" becomes deteriorated in PID control.

On the contrary, if each PID constant is so set that the "response to disturbance" becomes good, the "response to setting" becomes deteriorated.

The 4LC performs easy PID control with two degrees of freedom in which PID constants realizing good response to disturbance are adopted and the shape of the "response to setting" can be selected as either "fast", "medium" or "slow".

Select "fast", "medium" or "slow" using the control response parameter.

Select control mode "0" to "3" for performing PID control.

→ For details on the control mode switch, refer to Section 6.2.

Conventional PID control

- When PID constants are set so that the response to changes in set value becomes good

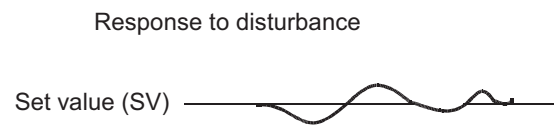
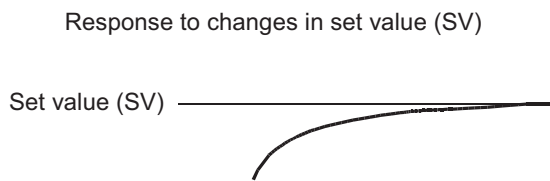

- When PID constants are set so that the response to disturbance becomes good

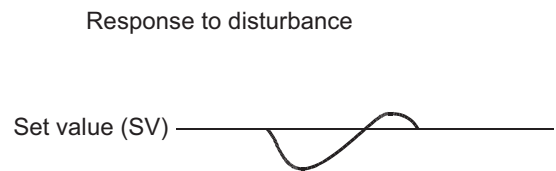
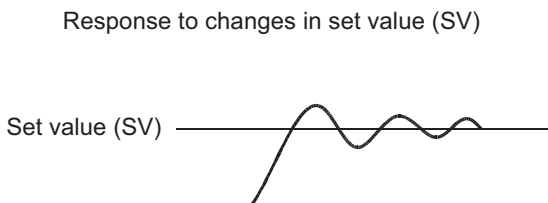

Easy PID control with two degrees of freedom

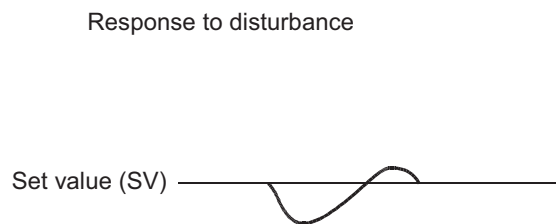
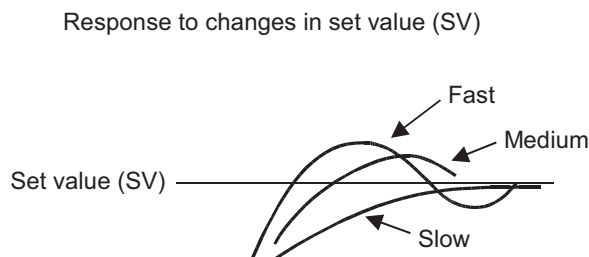

Associated buffer memory

BFM No.				Description	Reference
CH1	CH2	CH3	CH4		
#58	#98	#138	#178	Proportional band (P)/Heating proportional band (P)	Subsection 8.2.22
#60	#100	#140	#180	Integral time (I)	Subsection 8.2.24
#61	#101	#141	#181	Derivative time (D)	Subsection 8.2.25
#62	#102	#142	#182	Control response parameter	Subsection 8.2.26
#64	#104	#144	#184	Output limiter upper limit/Heating upper output limiter setting	Subsection 8.2.28
#65	#105	#145	#185	Output limiter lower limit	Subsection 8.2.29
#67	#107	#147	#187	Output change ratio limiter	Subsection 8.2.31
#240		#241		Control mode switch	Subsection 8.2.62

6.4.2 Overshoot prevention function

When a deviation continues for a long time, the PID arithmetic operation result exceeds the effective range of the control output. At this time, even if the deviation becomes smaller, it takes some time until the output comes within the effective range because of the integral operation. As a result, execution of an actual correction operation is delayed, and overshoot/undershoot occurs.

In order to prevent overshoot, the 4LC is equipped with the RFB (reset-feedback) limiter function.

The RFB limiter function feeds back the excessive quantity to the integral value and makes the arithmetic operation result be held at the limit point when the PID arithmetic operation result exceeds the limit point (upper/lower limit of the output limiter) so that the PID arithmetic operation result always remains inside the effective range. Accordingly, when a deviation becomes small, the correction operation is immediately performed.

The RFB limiter function is automatically activated while PID control is performed, and does not require setting.

Operation

(When the RFB limiter function is not provided)

(When the RFB limiter function is provided)

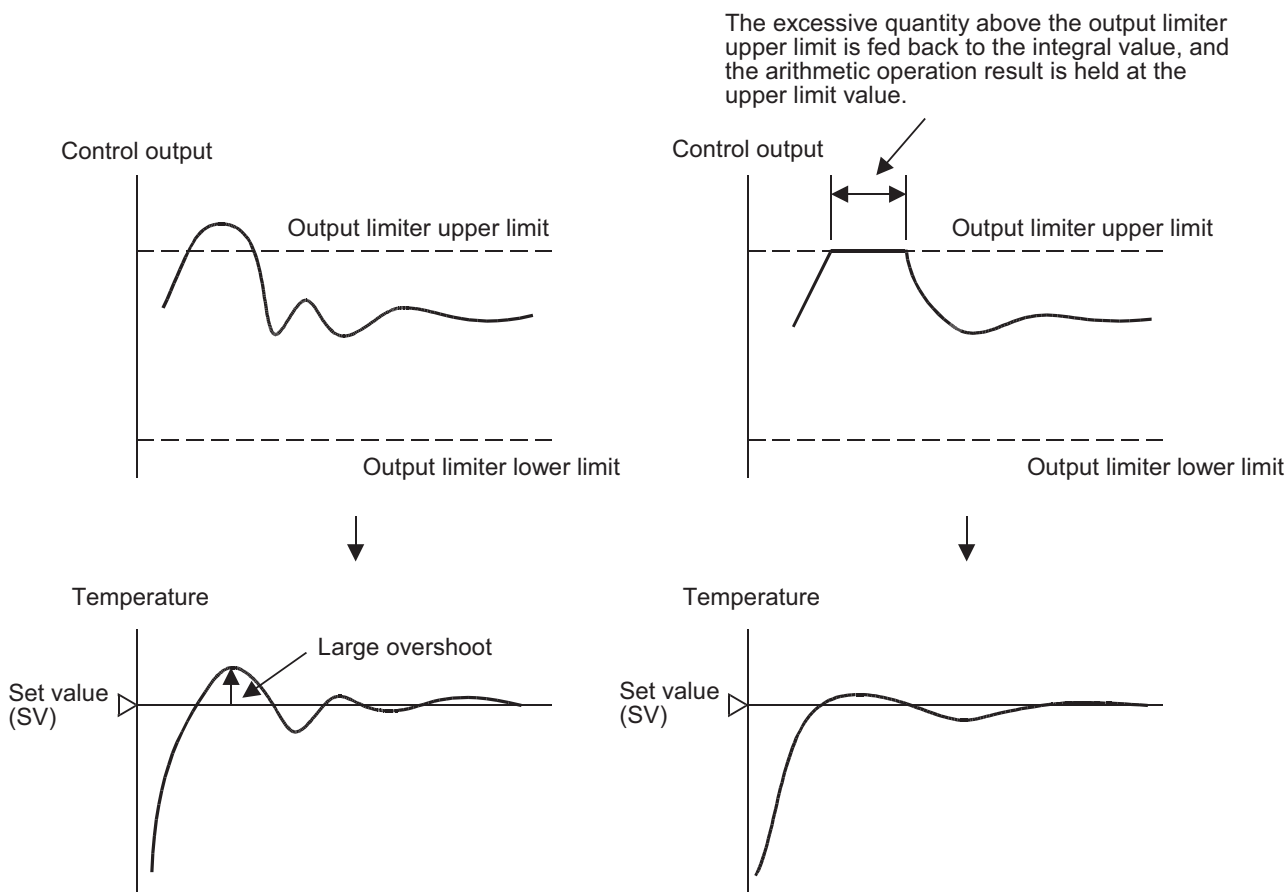

1 Introduction

2 Specification

3 System Configuration

4 Installation

5 Wiring

6 Introduction of Functions

7 Alarm

8 Buffer Memory

9 Program Examples

10 Troubleshooting

6.5 Two-position Control

When the proportional band (P) or heating proportional band (P) value is set to "0", the 4LC performs two-position control.

In two-position control, the control output (MV) is set to ON when the measured value (PV) is larger than the set value (SV) or OFF when the measured value (PV) is smaller than the set value (SV).

When the adjustment sensitivity (dead zone) is set, repetitious turning ON/OFF of the output around the set value (SV) can be prevented.

However, if the adjustment sensitivity (dead zone) is set to a large value, upward/downward fluctuation becomes large accordingly. If the adjustment sensitivity (dead zone) is set to a small value, chattering may be caused by small oscillations of measured values (PV).

Select control mode "0" to "7" for performing two-position control.

→ For details on the control mode switch, refer to Section 6.2.

Operation

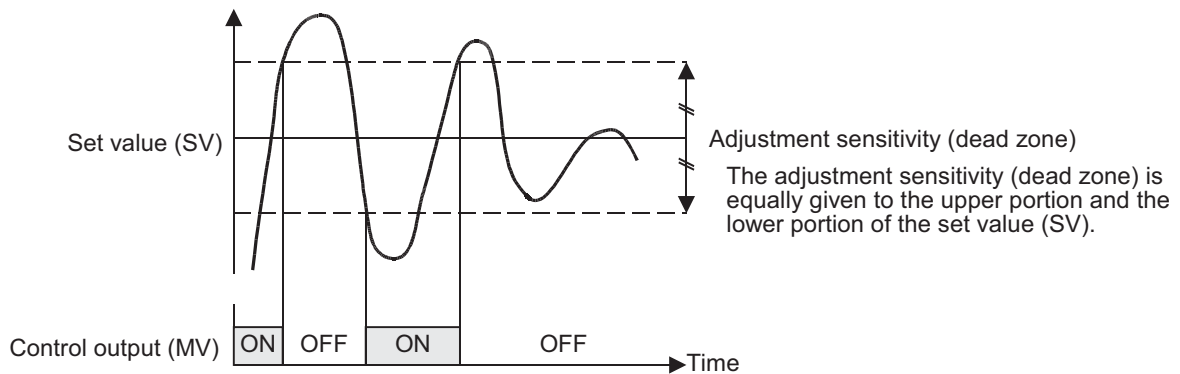

Associated buffer memory

BFM No.				Description	Reference
CH1	CH2	CH3	CH4		
#9	#10	#11	#12	Control output value (MV) monitor/ Heating control output value (MV) monitor	Subsection 8.2.4
#13	#14	#15	#16	Cooling control output value (MV) monitor	Subsection 8.2.5
#48	#88	#128	#168	Set value (SV)	Subsection 8.2.15
#58	#98	#138	#178	Proportional band (P)/Heating proportional band (P)	Subsection 8.2.22
#69	#109	#149	#189	Adjustment sensitivity (dead zone) setting	Subsection 8.2.23
#240		#241		Control mode switch	Subsection 8.2.62

6.6 Heating/cooling PID control

6.6.1 Heating/cooling PID control

Heating/cooling PID control handles two systems of outputs, heating control output and cooling control output.

The heating side performs the reverse operation in which the control output (MV) decreases as the measured value (PV) increases, and the cooling side performs the normal operation in which the control output (MV) increases as the measured value (PV) increases.

With regard to PID constants for heating/cooling control, set the proportional band (P) respectively for each of the heating side and the cooling side, and set a common value to the integral time (I) and derivative time (D) for both the heating side and the cooling side.

It means that the 4LC performs arithmetic operation using four PID constants, proportional band for the heating side, proportional band for the cooling side, common integral time and common derivative time.

It is possible to provide the dead band and overlap area at the point at which heating control and cooling control switch each other.

Select control mode "4" to "7" for performing heating/cooling PID control.

→ For details on the overlap/dead band, refer to Subsection 6.6.3.

→ For details on the control mode switch, refer to Section 6.2.

Operation

Control output value (MV)

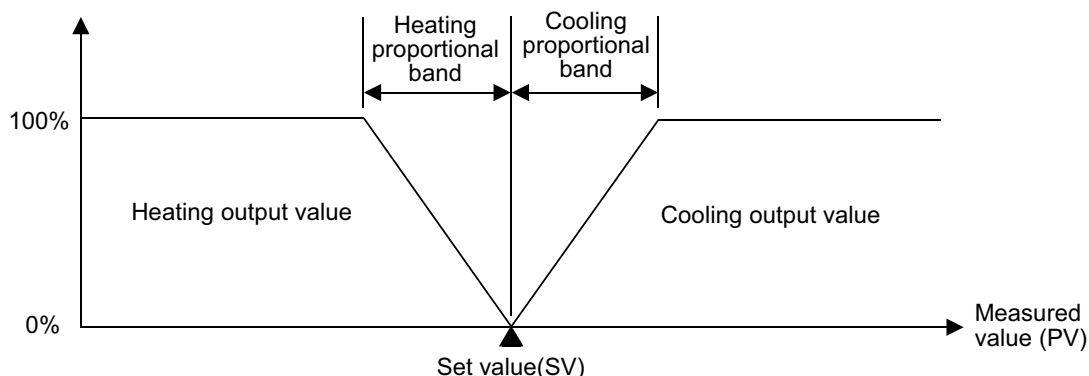

Associated buffer memory

BFM No.				Description	Reference
CH1	CH2	CH3	CH4		
#9	#10	#11	#12	Control output value (MV) monitor/ Heating control output value (MV) monitor	Subsection 8.2.4
#13	#14	#15	#16	Cooling control output value (MV) monitor	Subsection 8.2.5
#58	#98	#138	#178	Proportional band (P)/Heating proportional band (P)	Subsection 8.2.22
#59	#99	#139	#179	Cooling proportional band (P)	Subsection 8.2.23
#60	#100	#140	#180	Integral time (I)	Subsection 8.2.24
#61	#101	#141	#181	Derivative time (D)	Subsection 8.2.25
#62	#102	#142	#182	Control response parameter	Subsection 8.2.26
#63	#103	#143	#183	Overlap/Dead band	Subsection 8.2.27
#64	#104	#144	#184	Heating upper output limiter setting	Subsection 8.2.28
#66	#106	#146	#186	Cooling upper output limiter setting	Subsection 8.2.30
#70	#110	#150	#190	Heating control output period setting	Subsection 8.2.34
#71	#111	#151	#191	Cooling control output period setting	Subsection 8.2.35
#232				Cooling method setting	Subsection 8.2.54
#240		#241		Control mode switch	Subsection 8.2.62

Caution

- Cascade control is disabled when heating/cooling PID control is selected.
- The loop breaking alarm function is disabled in heating/cooling PID control.
- The loop breaking alarm dead zone is invalid in heating/cooling PID control.
- The MANUAL mode is not available in heating/cooling PID control.
- The output limiter lower limit is invalid in heating/cooling PID control.

6.6.2 Overshoot prevention function

The overshoot prevention function is enabled in heating/cooling PID control.

→ **For details on the Overshoot prevention function, refer to Subsection 6.4.2.**

6.6.3 Overlap/dead band function

The overlap/dead band function switches the significant point between control stability and energy saving by shifting the temperature at which cooling control is started.

Overlap

The overlap area indicates the temperature area where both heating output and cooling output are given. Control stability is improved in the overlap area where the temperature change caused by outputs is small due to trade-off between two outputs.

For setting the overlap area, set a negative value to the overlap/dead band buffer memory.

Operation example 1 (When the overlap area is set)

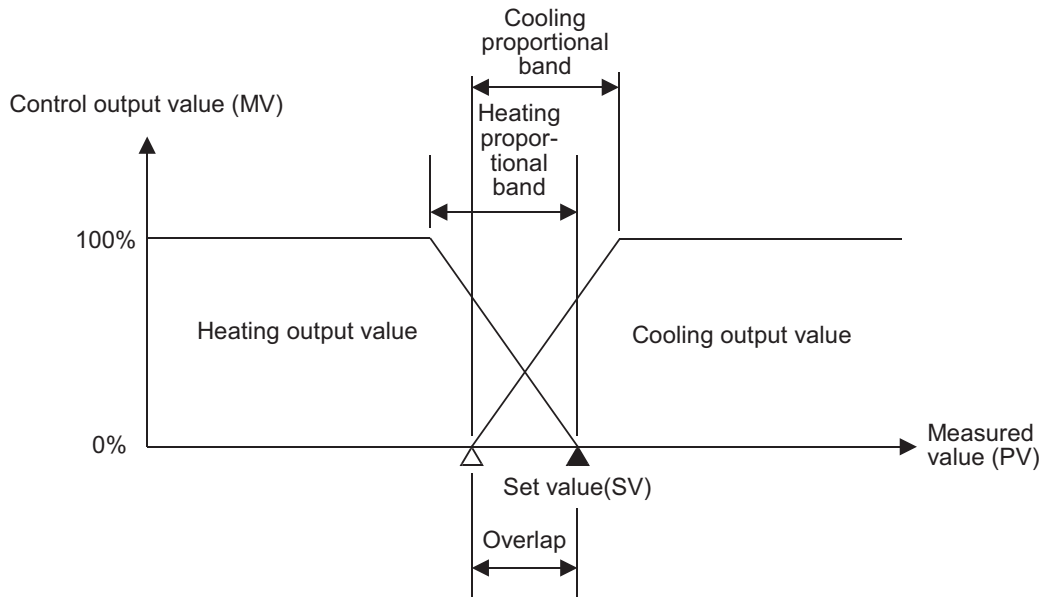

Dead band

The dead band is located between the proportional band on the heating side and the proportional band on the cooling side. Both the control output on the heating side and the control output on the cooling side are not output when the measured value (PV) is located in the dead band. As a result, the energy-saving effect is given.

For setting the dead band, set a positive value to the overlap/dead band buffer memory.

Operation example 2 (When the dead band is set)

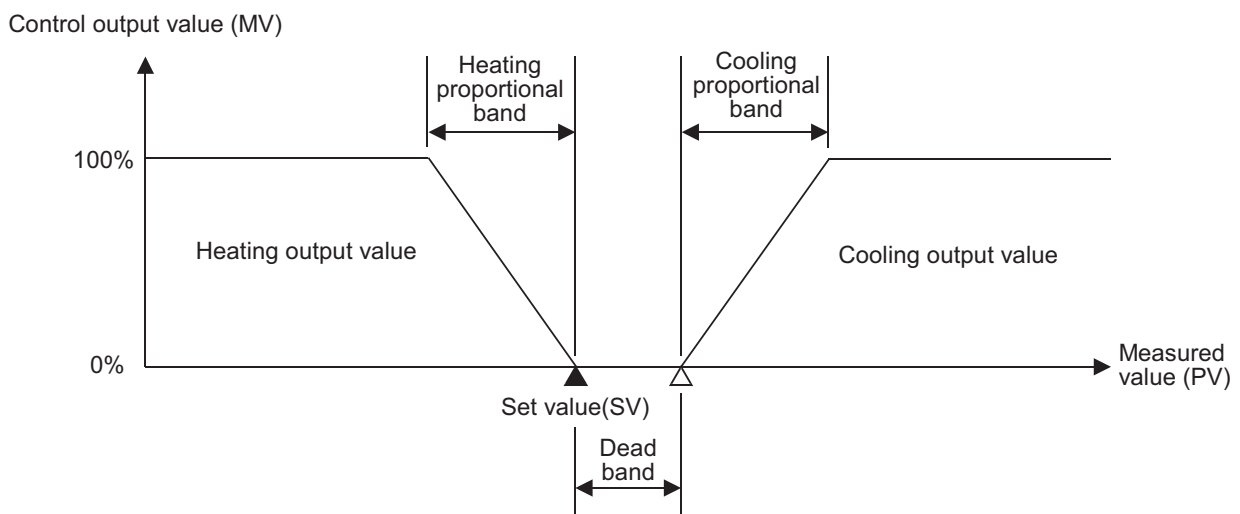

- 1 Introduction
- 2 Specification
- 3 System Configuration
- 4 Installation
- 5 Wiring
- 6 Introduction of Functions
- 7 Alarm
- 8 Buffer Memory
- 9 Program Examples
- 10 Troubleshooting

Associated buffer memory

BFM No.				Description	Reference
CH1	CH2	CH3	CH4		
#58	#98	#138	#178	Proportional band (P)/Heating proportional band (P)	Subsection 8.2.22
#59	#99	#139	#179	Cooling proportional band (P)	Subsection 8.2.23
#63	#103	#143	#183	Overlap/Dead band	Subsection 8.2.27

Caution

- The overlap/dead band buffer memories are invalid in two-position control.
- The overlap/dead band buffer memories store "0" in PID control.
- Set the overlap area within the proportional band.

6.6.4 Cooling method

This function switches the cooling method (among "air cooling type", "water cooling type" and "cooling gain linear type") in accordance with the cooling unit type for heating/cooling PID control. Because cooling characteristics are considerably different between the air cooling method and the water cooling method, PID constants suitable to the cooling unit can be obtained by auto tuning if the correct cooling method is selected.

Air cooling type/water cooling type

The adopted algorithm postulates heating/cooling control for plastic molding machines.

This algorithm offers good response to the set value also in units having a cooling mechanism with nonlinear characteristics, and achieves response characteristics to the set value with a small overshoot.

Cooling gain linear type

The adopted algorithm postulates for applications without nonlinear cooling capacity.

An algorithm is used for applications without nonlinear cooling capacity such as an electronic cooler using a Peltier device is adopted.

Associated buffer memory

BFM No.				Description	Reference
CH1	CH2	CH3	CH4		
#232				Cooling method setting	Subsection 8.2.54

Caution

Set this buffer memory before performing auto tuning because the setting affects arithmetic operation results of PID constants acquired by auto tuning.

6.7 Cascade control

6.7.1 Cascade control

Cascade control combines master channel control and slave channel control into one control loop. Cascade control is suitable for situations where there is a large time delay between the temperature near a heat source and the temperature of the object to be controlled.

The master channel performs PID arithmetic operation using the measured value (PV) of the control target or an external input value as the input, converts the control output into the cascade signal using the cascade bias and cascade gain, and then corrects the set value (SV) of the slave channel.

The slave channel performs PID control using the set value (SV) converted into the cascade signal.

Up to 2 control loops are available in the 4LC.

Set the control mode to "0" to "3" for performing cascade control.

The combination of available master channel and slave channel is determined for each control loop as shown below.

Control loop	Master channel	Slave channel	Control output
1	Channel 1	Channel 2	OUT2
2	Channel 3	Channel 4	OUT4

→ For details on the control mode switch, refer to Section 6.2.

Cascade control block diagram (reference)

This diagram shows an example of the control loop 1.

Control loop1

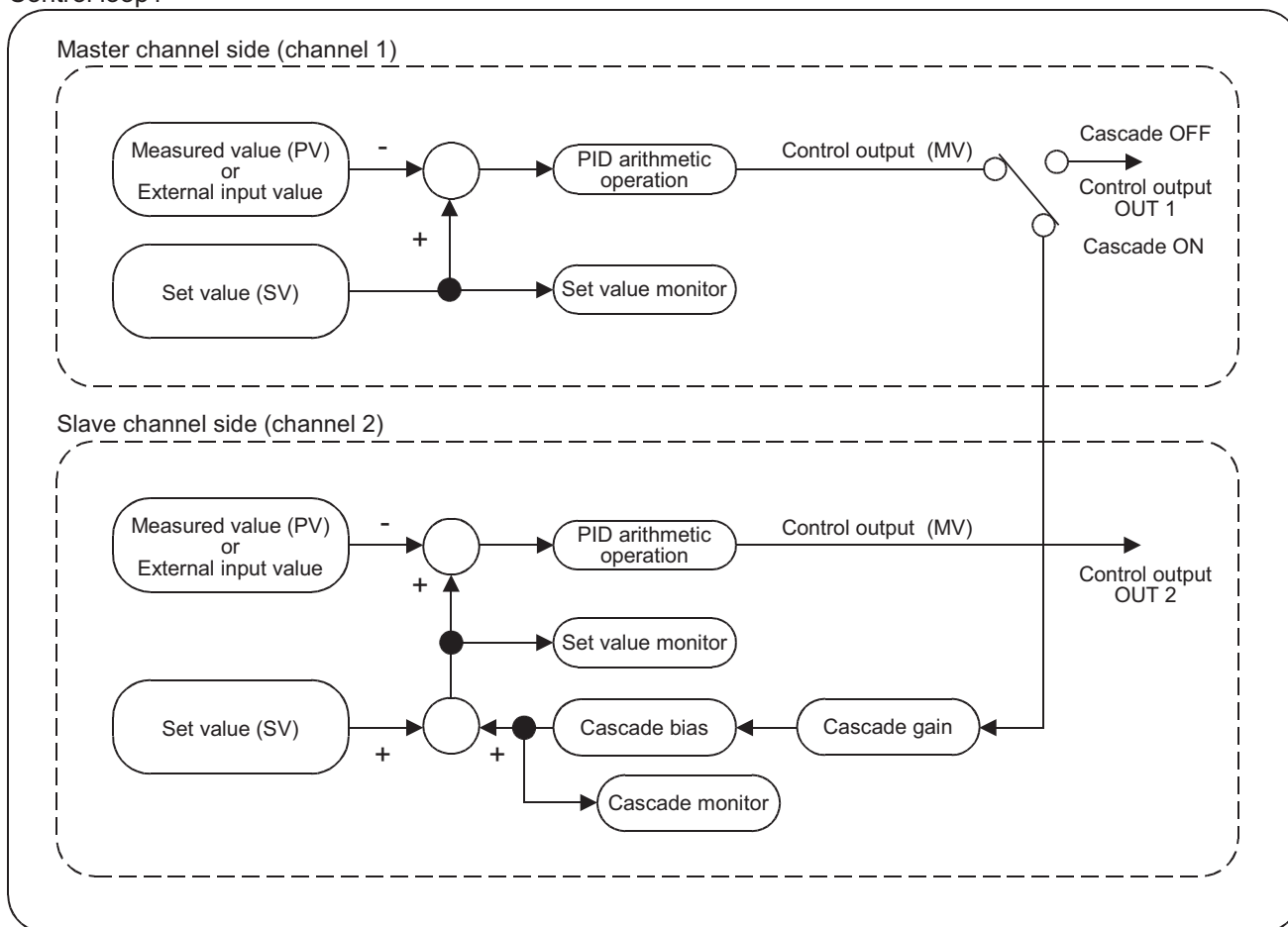

- 1 Introduction
- 2 Specification
- 3 System Configuration
- 4 Installation
- 5 Wiring
- 6 Introduction of Functions
- 7 Alarm
- 8 Buffer Memory
- 9 Program Examples
- 10 Troubleshooting

Conditions for enabling cascade control

- The master channel is separated from the slave channel, and the proper intermediate control quantity can be selected.
- The response speed of the control target in the slave channel is sufficiently faster than the response speed of the control target in the master channel.

Associated buffer memory

BFM No.				Description	Reference
CH1	CH2	CH3	CH4		
#5	#6	#7	#8	Measured value (PV)	Subsection 8.2.3
#9	#10	#11	#12	Control output value (MV) monitor/ Heating control output value (MV) monitor	Subsection 8.2.4
#25	#26	#27	#28	External input value	Subsection 8.2.8
#40	#41	#42	#43	Set value monitor	Subsection 8.2.13
#44	#45	#46	#47	Control mode monitor	Subsection 8.2.14
#48	#88	#128	#168	Set value (SV)	Subsection 8.2.15
#58	#98	#138	#178	Proportional band (P)/Heating proportional band (P)	Subsection 8.2.22
#60	#100	#140	#180	Integral time (I)	Subsection 8.2.24
#61	#101	#141	#181	Derivative time (D)	Subsection 8.2.25
#62	#102	#142	#182	Control response parameter	Subsection 8.2.26
	#240		#241	Control mode switch	Subsection 8.2.62
	#242		#243	SV tracking selection	Subsection 8.2.63
	#244		#245	Cascade ON/OFF	Subsection 8.2.64
	#246		#247	Cascade gain	Subsection 8.2.65
	#248		#249	Cascade bias	Subsection 8.2.66
	#250		#251	Cascade monitor	Subsection 8.2.67

Caution

- Cascade control is enabled only when PID control is selected. (Cascade control is also enabled also in the MANUAL mode.)
- Auto tuning and startup tuning are disabled while cascade control is being performed.
- The alarm waiting operation is disabled on the slave channel side when the set value (SV) is changed.

6.7.2 Tuning during cascade control

Auto tuning and startup tuning are disabled while cascade control is being performed.

Perform tuning in advance while cascade control is OFF, and then set PID constants regarded as approximate values.

Perform tuning respectively for each channel, and stop control of the channel where tuning is not performed (by setting the operation mode to "0 : Unused", "1 : Monitor" or "2 : Monitor + Alarm").

Example of tuning procedure

- 1) Turn ON control of only the slave channel, perform auto tuning, and obtain PID constants for the slave channel.
Set the operation mode of the master channel to "1 : Monitor" or "2 : Monitor + Alarm", and the control output should only be wired to a slave channel.

Point

When both the master channel and the slave channel mainly perform PID control in cascade control, the integral operation is performed in each channel, the low frequency gain increases too much, and an oscillating low-frequency response may occur.

Accordingly, it is generally recommended to avoid the above phenomenon by selecting P control (I = 0, D = 0) or PD control (I = 0) for the slave channel.

Determine P control constants or PD control constants based on the auto tuning result performed in the slave channel, and reduce the proportional band by 60 to 70%.

- 2) Turn ON control of only the master channel, perform auto tuning, and obtain PID constants for the master channel.
Set the operation mode of the slave channel to "1 : Monitor" or "2 : Monitor + Alarm", and the control output should only be wired to a master channel.
- 3) Set a same set value (SV) for both the master channel and the slave channel.
- 4) Turn OFF cascade control, and control only the slave channel.
Set the operation mode of the master channel to "1 : Monitor" or "2 : Monitor + Alarm", and the control output should only be wired to a slave channel.
- 5) When the measured value (PV) becomes stable in both the master channel and the slave channel, obtain the measured value (PV) difference E_n between the master channel and the slave channel.
 $E_n = \text{Measured value (PV) of master channel} - \text{Measured value (PV) of slave channel}$
- 6) The span of the set value monitor of a slave channel is determined to be about 4 times of the measured value (PV) difference E_n of the master channel from Procedure 5) and slave channel, the cascade gain is set up as follows.

Normal operation :

$$\text{Cascade gain} = - \frac{\text{Span of the set value monitor of slave channel}}{\text{Input span of slave channel}} \quad (\text{number of times})$$

Reverse operation :

$$\text{Cascade gain} = + \frac{\text{Span of the set value monitor of slave channel}}{\text{Input span of slave channel}} \quad (\text{number of times})$$

- 7) Cascade bias is set up as follows.

Normal operation :

$$\text{Cascade bias} = + \frac{\text{Span of the set value monitor of slave channel} / 2}{\text{Input span of slave channel}} \times 100 (\%)$$

Reverse operation :

$$\text{Cascade bias} = - \frac{\text{Span of the set value monitor of slave channel} / 2}{\text{Input span of slave channel}} \times 100 (\%)$$

- 8) The set value (SV) of the slave channel is set up as follows. After the measured value (PV) becomes stable in both the master channel and the slave channel.

Normal operation :

$$\text{Set value (SV) of the slave channel} = E_n - \text{Set value (SV) of master channel (SV)}$$

Reverse operation :

$$\text{Set value (SV) of the slave channel} = \text{Set value (SV) of master channel (SV)} - E_n$$

- 9) Set the operation mode of the master channel to "3 : Monitor + Alarm + Control", and perform cascade control (cascade ON).

While checking the control status, manually adjust PID constants for the master channel.

The control output should only be wired to a master channel.

6.7.3 SV tracking selection function

The SV tracking selection function makes the slave channel set value (SV) track the set value (value stored in the set value monitor buffer memory) just before changeover to cascade OFF when the cascade control function is changed from ON to OFF.

Control group 1 (GR1) : The setting is applied to CH1 and CH2.

Control group 2 (GR2) : The setting is applied to CH3 and CH4.

Example of operation 1 (When SV tracking is provided)

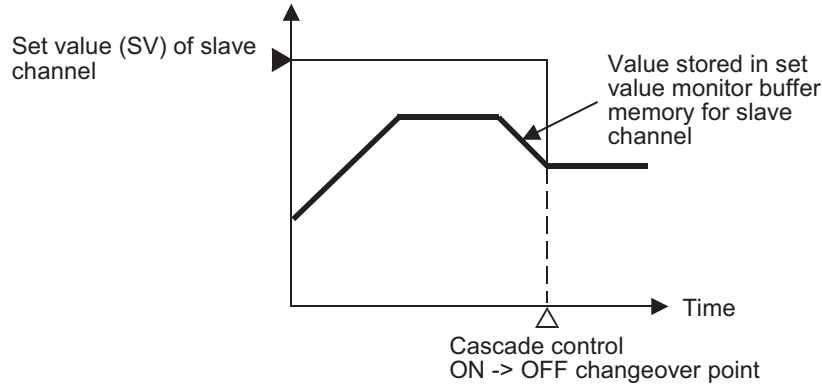

Example of operation 2 (When SV tracking is not provided)

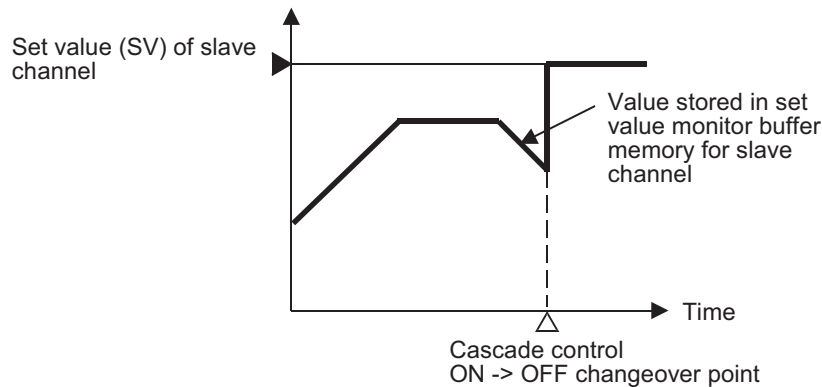

Associated buffer memory

BFM No.				Description	Reference
CH1	CH2	CH3	CH4		
#40	#41	#42	#43	Set value monitor	Subsection 8.2.13
#48	#88	#128	#168	Set value (SV)	Subsection 8.2.15
#242		#243		SV tracking selection	Subsection 8.2.63
#244		#245		Cascade ON/OFF	Subsection 8.2.64

Point

This function prevents drastic change in the set value (SV) caused when the cascade control function is changed from ON to OFF.

6.8 Auto Tuning Function

6.8.1 AT (Auto tuning)

The auto tuning function automatically measures, calculates and sets optimal PID constants in accordance with the set temperature.

The auto tuning function is available in PID control and heating/cooling PID control.

Write "1" to the AT execution command buffer memory to perform auto tuning.

When auto tuning starts, two-position control is performed using the set value (SV). By two-position control, the output is forcedly hunted and its amplitude and oscillation cycle are measured. PID constants are calculated based on the measured values, and stored in each buffer memory.

The buffer memories shown below store calculated values.

Applicable buffer memory	Calculated value	Value to be set
Proportional band (P)/ Heating proportional band (P)	Less than 0.1%	0.1%
	1000.0% or more	1000.0%
Integral time (I)	Less than 1 sec.	1 sec.
	3600 sec. or more	3600 sec.
Derivative time (D)	3600 sec. or more	3600 sec.
Loop breaking alarm judgement time	The calculated integral time multiplied by "2" is automatically written. However, "0" remains stored when the loop breaking alarm judgment time is set to "0" when auto tuning is finished.	

When auto tuning finishes normally, control continues with new calculated PID constants. The AT bias can be set for auto tuning.

Example of operation (When AT is performed while the temperature is rising)

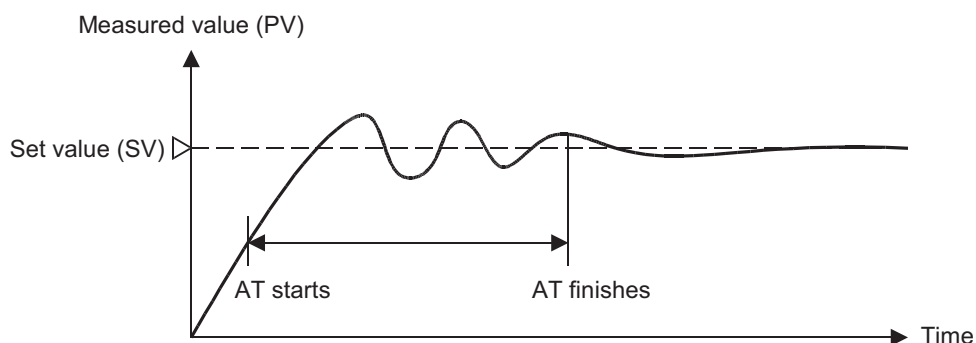

Point

- Before starting auto tuning, confirm that all conditions for performing and aborting auto tuning (refer to Subsection 6.8.2) are satisfied.
- Before starting auto tuning, set the output limiter upper limit/heating output limiter upper limit to "100%", set the output limiter lower limit to "0%", and set the output change ratio limiter function to OFF so that optimal PID constants can be calculated by auto tuning.
- When auto tuning is finished normally, write newly calculated PID constants to the EEPROM using the set value backup command so that auto tuning becomes unnecessary from the next power ON.
- When auto tuning is finished normally, PID constants and loop breaking alarm judgement time are written to the buffer memory, and then the AT execution flag turns OFF. Because the AT execution command buffer memory does not become "0" automatically, write "0" manually.

Associated buffer memory

BFM No.				Description	Reference
CH1	CH2	CH3	CH4		
#0				Flag (b4 to b7 AT/ST abnormal end flag)	Subsection 8.2.1
#1	#2	#3	#4	Event (b14 AT (auto tuning) being performed)	Subsection 8.2.2
#5	#6	#7	#8	Measured value (PV)	Subsection 8.2.3
#48	#88	#128	#168	Set value (SV)	Subsection 8.2.15
#56	#96	#136	#176	AT (auto tuning) execution command	Subsection 8.2.20
#58	#98	#138	#178	Proportional band (P)/Heating proportional band (P)	Subsection 8.2.22
#59	#99	#139	#179	Cooling proportional band (P)	Subsection 8.2.23
#60	#100	#140	#180	Integral time (I)	Subsection 8.2.24
#61	#101	#141	#181	Derivative time (D)	Subsection 8.2.25
#64	#104	#144	#184	Output limiter upper limit/Heating upper output limiter	Subsection 8.2.28
#65	#105	#145	#185	Output limiter lower limit	Subsection 8.2.29
#67	#107	#147	#187	Output change ratio limiter	Subsection 8.2.31
#73	#113	#153	#193	Setting change ratio limiter	Subsection 8.2.37
#74	#114	#154	#194	AT (auto tuning) bias	Subsection 8.2.38
#78	#118	#158	#198	Loop breaking alarm judgement time	Subsection 8.2.42
#254				Set value backup command	Subsection 8.2.70

Caution

- While the setting change ratio limiter is operating, auto tuning is started when the set value (SV) reaches the auto tuning point.
- If control is started while both the AT execution command buffer memory and ST execution command buffer memory are set to "1", auto tuning is performed.
- If the AT execution command buffer memory is set to "1" while startup tuning is being performed, startup tuning is aborted and auto tuning is started.
- If auto tuning is performed while the output change flag ratio limiter is set to any value other than "0", optimal PID constants may not be acquired.
Do not use the output change ratio limiter when performing auto tuning.
- The loop breaking alarm function is disabled while auto tuning is being performed.

6.8.2 Conditions for performing and aborting AT (auto tuning)

1. Conditions for performing AT (auto tuning)

Auto tuning can be performed when all the following conditions are satisfied.

- The control start/stop changeover set to "1 : Starts control".
- The operation mode set to "3 : Monitor + alarm + Control".
- The AUTO/MANUAL mode changeover set to "0 : AUTO mode".
- The value stored in the output limiter upper limit/heating output limiter upper limit buffer memory is not the same as the value stored in the output limiter lower limit buffer memory.
- The value stored in the output limiter upper limit/heating output limiter upper limit buffer memory and the value stored in the cooling output limiter upper limit buffer memory are "1 (0.1%)" or more.
- The value stored in the output limiter lower limit buffer memory is "999 (99.9%)" or less.
- Input value error (upper limit or lower limit) has not occurred.
- The proportional band setting is not "0.0 (two-position control)".
- The cascade ON/OFF set to "0 : Cascade OFF".
- The AT/ST abnormal end flag is "0 (OFF)".

2. Conditions for aborting AT (auto tuning)

If any of the following conditions are satisfied while auto tuning is being performed, auto tuning is forcibly aborted and the AT/ST abnormal end flag turns ON.

- Input value error (upper limit or lower limit) occurs.
- The set value (SV) is changed.
- The control start/stop changeover function is changed to "0 : Stops control".
- The AUTO/MANUAL mode changeover function is changed to "1 : MANUAL mode".
- The operation mode is changed to any setting other than "3 : Monitor + Alarm + Control".
- The AT bias is changed.
- The sensor correction value is changed.
- The primary delay digital filter setting is changed.
- The value stored in the output limiter upper limit/heating output limiter upper limit buffer memory, the value stored in the cooling output limiter upper limit buffer memory or the value stored in the output limiter lower limit buffer memory is changed.
- The proportional band setting is changed to "0.0 : two-position control".
- A calculated PID constant acquired by auto tuning exceeds the setting range.
 - Proportional band/heating proportional band and cooling proportional band : 0.1 to 1000.0
 - Integral time : 1 to 3600
 - Derivative time : 0 to 3600
- The AT execution command buffer memory is set to "0 : Stops AT".
(AT/ST abnormal end flag does not turn ON.)
- Power failure occurs.
(AT/ST abnormal end flag does not turn ON.)
- The cascade control ON/OFF function is set to "1 : Cascade ON".
- The cooling method setting is changed.
- Auto tuning is not finished in approximately 2 hours.
- Hardware error is detected.
 - Sum check error caused by 24V DC power supply error or adjustment data error
 - Cold contact temperature compensation data error
 - A/D converter error

Associated buffer memory

BFM No.				Description	Reference
CH1	CH2	CH3	CH4		
#0				Flag (b2 24V DC power supply error) (b4 to b7 AT/ST abnormal end flag) (b8 Adjustment data error) (b9 Cold contact temperature compensation data error) (b10 A/D converted value error)	Subsection 8.2.1
#1	#2	#3	#4	Event (b0 Input error (upper limit)) (b1 Input error (lower limit)) (b14 AT (auto tuning) being performed)	Subsection 8.2.2
#5	#6	#7	#8	Measured value (PV)	Subsection 8.2.3
#29				Control start/stop changeover	Subsection 8.2.9
#48	#88	#128	#168	Set value (SV)	Subsection 8.2.15
#54	#94	#134	#174	AUTO/MANUAL mode changeover	Subsection 8.2.18
#56	#96	#136	#176	AT (auto tuning) execution command	Subsection 8.2.20
#57	#97	#137	#177	Operation mode	Subsection 8.2.21
#58	#98	#138	#178	Proportional band (P)/Heating proportional band (P)	Subsection 8.2.22
#59	#99	#139	#179	Cooling proportional band (P)	Subsection 8.2.23
#60	#100	#140	#180	Integral time (I)	Subsection 8.2.24
#61	#101	#141	#181	Derivative time (D)	Subsection 8.2.25
#64	#104	#144	#184	Output limiter upper limit/Heating upper output limiter	Subsection 8.2.28
#65	#105	#145	#185	Output limiter lower limit	Subsection 8.2.29
#66	#106	#146	#186	Cooling upper output limiter setting	Subsection 8.2.30
#67	#107	#147	#187	Output change ratio limiter	Subsection 8.2.31
#68	#108	#148	#188	Sensor correction value setting	Subsection 8.2.32
#72	#112	#152	#192	Primary delay digital filter setting	Subsection 8.2.36
#74	#114	#154	#194	AT (auto tuning) bias	Subsection 8.2.38
#78	#118	#158	#198	Loop breaking alarm judgement time	Subsection 8.2.42
#208	#214	#220	#226	Input type	Subsection 8.2.52
#244		#245		Cascade ON/OFF	Subsection 8.2.64
#254				Set value backup command	Subsection 8.2.70

6.8.3 AT (auto tuning) bias

Set the auto tuning bias so that the measured value (PV) does not exceed the set value (SV) during auto tuning.

The auto tuning function performs two-position control using the set value (SV), hunts the measured value (PV), then calculates and sets each PID constant. However, for some control targets, overshoot caused by hunting is not desirable. When the AT bias is set, the set value (SV) = AT point with which auto tuning is performed can be changed.

Example of operation (When the AT bias is set to "-")

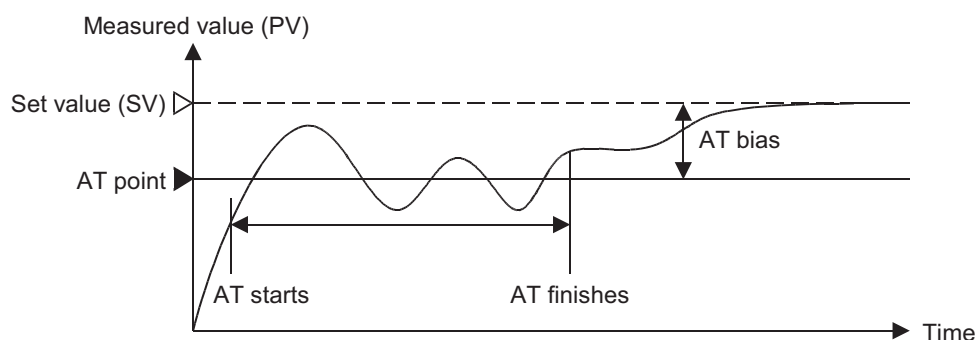

Associated buffer memory

BFM No.				Description	Reference
CH1	CH2	CH3	CH4		
#1	#2	#3	#4	Event (b14 AT (auto tuning) being performed)	Subsection 8.2.2
#73	#113	#153	#193	Setting change ratio limiter	Subsection 8.2.37
#74	#114	#154	#194	AT (auto tuning) bias	Subsection 8.2.38
#76	#116	#156	#196	Setting limiter upper limit	Subsection 8.2.40
#77	#117	#157	#197	Setting limiter lower limit	Subsection 8.2.41

Caution

- When the set value (SV) added by the AT bias (AT point) value exceeds the setting limiter range, the 4LC performs auto tuning using the setting limiter value.
- If the setting change ratio limiter is set to any value other than "0" when auto tuning is started, the set value (SV) changes in accordance with the setting of the setting change ratio limiter until the AT point. When the set value reaches the AT point, b14 "Auto tuning being performed" of the event buffer memory turns ON, and auto tuning is started.

1	Introduction
2	Specification
3	System Configuration
4	Installation
5	Wiring
6	Introduction of Functions
7	Alarm
8	Buffer Memory
9	Program Examples
10	Troubleshooting

6.9 Startup Tuning Function

6.9.1 ST (startup tuning)

The startup tuning function automatically measures, calculates and sets optimal PID constants based on the response characteristics of the control target when control is started or when the set value (SV) is changed. Startup tuning works as easy as auto tuning, and acquires PID constants in a short time at start of control without disturbing the controllability for a slow response control target. This function acquires PID constants every time the set value (SV) is changed for a control target requiring different PID constants at each temperature setting.

Startup tuning is automatically started when control is started or when the set value (SV) is changed while all conditions for performing startup tuning are satisfied.

The following buffer memories store calculated values.

Applicable buffer memory	Calculated value	Value to be set
Proportional band (P)	Less than 0.1%	0.1%
	1000.0% or more	1000.0%
Integral time (I)	Less than 1 sec.	1 sec.
	3600 sec. or more	3600 sec.
Derivative time (D)	3600 sec. or more	3600 sec.

When startup tuning is normally finished, the 4LC continues control using new calculated PID constants.

Example of operation

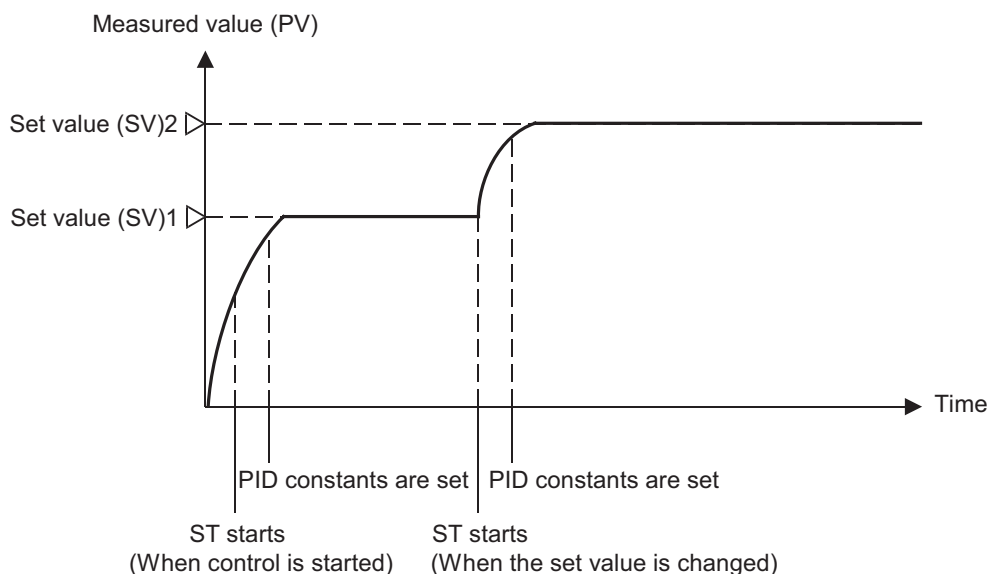

Explanation of operation

It is assumed that all conditions for performing startup tuning are satisfied.

→ For the conditions for performing startup tuning, refer to Subsection 6.9.2.

- 1) Startup tuning is started when control is started. Optimal PID constants are obtained automatically based on the response characteristics of the control target, and each constant is stored in the corresponding buffer memory.
- 2) Startup tuning is started when the set value is changed. Optimal PID constants are obtained automatically based on the response characteristics of the control target, and each constant is stored in the corresponding buffer memory.

Point

- Before using the startup tuning function, confirm that all conditions for performing startup tuning and for aborting startup tuning (refer to Subsection 6.9.2) are satisfied.
- Before starting startup tuning, set the output limiter upper limit to "100%", set the output limiter lower limit to "0%", and set the output change ratio limiter function to OFF so that optimal PID constants can be calculated by startup tuning.
- When startup tuning is finished normally, PID constants are written to the buffer memories, and then the ST execution flag turns OFF. Because the ST execution command buffer memory does not become "0" automatically, write "0" manually.
However, it is not necessary to set the ST execution command buffer memory to "0" if startup tuning should be started when the set value (SV) is changed.

Associated buffer memory

BFM No.				Description	Reference
CH1	CH2	CH3	CH4		
#0				Flag (b4 to b7 AT/ST abnormal end flag)	Subsection 8.2.1
#1	#2	#3	#4	Event (b11 ST (startup tuning) being performed)	Subsection 8.2.2
#5	#6	#7	#8	Measured value (PV)	Subsection 8.2.3
#48	#88	#128	#168	Set value (SV)	Subsection 8.2.15
#58	#98	#138	#178	Proportional band (P)/Heating proportional band (P)	Subsection 8.2.22
#60	#100	#140	#180	Integral time (I)	Subsection 8.2.24
#61	#101	#141	#181	Derivative time (D)	Subsection 8.2.25
#64	#104	#144	#184	Output limiter upper limit/Heating upper output limiter	Subsection 8.2.28
#65	#105	#145	#185	Output limiter lower limit	Subsection 8.2.29
#67	#107	#147	#187	Output change ratio limiter	Subsection 8.2.31
#87	#127	#167	#207	ST (startup tuning) execution command	Subsection 8.2.51
#254				Set value backup command	Subsection 8.2.70

Caution

- Startup tuning is enabled only in PID control.
- Make sure to turn ON the heater at the same time or before starting startup tuning if startup tuning should be started at the start of control.
- Before starting startup tuning, confirm that the difference between the measured value (PV) and the set value (SV) is twice or more the proportional band.
- If control is started while both the AT execution command buffer memory and ST execution command buffer memory are set to "1", auto tuning is performed.
- If the AT execution command buffer memory is set to "1" while startup tuning is being performed, startup tuning is aborted and auto tuning is started.
- If startup tuning is performed while the output change ratio limiter is set to any value other than "0", optimal PID constants may not be acquired.
Do not use the output change ratio limiter when performing startup tuning.

1

Introduction

2

Specification

3

System
Configuration

4

Installation

5

Wiring

6

Introduction of
Functions

7

Alarm

8

Buffer Memory

9

Program
Examples

10

Troubleshooting

6.9.2 Conditions for performing and aborting ST (startup tuning)

1. Conditions for performing ST (startup tuning)

Startup tuning can be performed when all the following conditions are satisfied.

- The ST execution command buffer memory is set to "1 : Performs ST".
- The control start/stop changeover set to "1 : Starts control".
- The operation mode set to "3 : Monitor + alarm + Control".
- The AUTO/MANUAL mode changeover set to "0 : AUTO mode".
- The value stored in the output limiter upper limit buffer memory is not the same as the value stored in the output limiter lower limit buffer memory.
- The value stored in the output limiter upper limit buffer memory is "1 (0.1%)" or more.
- The value stored in the output limiter lower limit buffer memory is "999 (99.9%)" or less.
- Input value error (upper limit or lower limit) has not occurred.
- The proportional band setting is not "0.0 (two-position control)".
- The cascade ON/OFF set to "0 : Cascade OFF".
- PID control is selected. (ST cannot be performed during heating/cooling PID control)
- The measured value (PV) is stable if startup tuning should be started when the set value (SV) is changed.
- The output changes when startup tuning is started, and becomes saturated at the output limiter upper limit or output limiter lower limit.
- Before starting startup tuning, confirm that the difference between the measured value (PV) and the set value (SV) is twice or more the proportional band.
- The AT execution command buffer memory is set to "0 : Stops AT".
- The AT/ST abnormal end flag is "0 (OFF)".

2. Conditions for aborting ST (startup tuning)

If any of the following conditions are satisfied while startup tuning is being performed, startup tuning is forcibly aborted and the AT/ST abnormal end flag turns ON.

- Input value error (upper limit or lower limit) occurs.
- The control start/stop changeover function is changed to "0 : Stops control".
- The AUTO/MANUAL mode changeover function is changed to "1 : MANUAL mode".
- The operation mode is changed to any setting other than "3 : Monitor + Alarm + Control".
- The sensor correction value is changed.
- The primary delay digital filter setting is changed.
- The value stored in the output limiter upper limit buffer memory or the value stored in the output limiter lower limit buffer memory is changed.
- The proportional band setting is changed to "0.0 : two-position control".
- A calculated PID constant acquired by startup tuning exceeds the setting range.
 - Proportional band : 0.1 to 1000.0
 - Integral time : 1 to 3600
 - Derivative time : 0 to 3600
- The ST execution command buffer memory is set to "0 : Stops ST".
(AT/ST abnormal end flag does not turn ON.)
- Power failure occurs.
(AT/ST abnormal end flag does not turn ON.)
- The cascade control ON/OFF function is set to "1 : Cascade ON".
- Startup tuning is not finished in approximately 100 minutes.
- The AT execution command buffer memory is set to "1 : Performs AT".
(The AT/ST abnormality flag does not turn ON.)

- The output saturation time (Time when the output value has stopped at output limiter upper limit or output limiter lower limit) is short.
- Hardware error is detected.
 - Sum check error caused by 24V DC power supply error or adjustment data error
 - Cold contact temperature compensation data error
 - A/D converter error

Associated buffer memory

BFM No.				Description	Reference
CH1	CH2	CH3	CH4		
#0				Flag (b2 24V DC power supply error) (b4 to b7 AT/ST abnormal end flag) (b8 Adjustment data error) (b9 Cold contact temperature compensation data error) (b10 A/D converted value error)	Subsection 8.2.1
#1	#2	#3	#4	Event (b0 Input error (upper limit)) (b1 Input error (lower limit)) (b11 ST (startup tuning) being performed) (b14 AT (auto tuning) being performed)	Subsection 8.2.2
#5	#6	#7	#8	Measured value (PV)	Subsection 8.2.3
#29				Control start/stop changeover	Subsection 8.2.9
#48	#88	#128	#168	Set value (SV)	Subsection 8.2.15
#54	#94	#134	#174	AUTO/MANUAL mode changeover	Subsection 8.2.18
#56	#96	#136	#176	AT (auto tuning) execution command	Subsection 8.2.20
#57	#97	#137	#177	Operation mode	Subsection 8.2.21
#58	#98	#138	#178	Proportional band (P)/Heating proportional band (P)	Subsection 8.2.22
#60	#100	#140	#180	Integral time (I)	Subsection 8.2.24
#61	#101	#141	#181	Derivative time (D)	Subsection 8.2.25
#64	#104	#144	#184	Output limiter upper limit/Heating upper output limiter	Subsection 8.2.28
#65	#105	#145	#185	Output limiter lower limit	Subsection 8.2.29
#67	#107	#147	#187	Output change ratio limiter	Subsection 8.2.31
#68	#108	#148	#188	Sensor correction value setting	Subsection 8.2.32
#72	#112	#152	#192	Primary delay digital filter setting	Subsection 8.2.36
#87	#127	#167	#207	ST (startup tuning) execution command	Subsection 8.2.51
#208	#214	#220	#226	Input type	Subsection 8.2.52
#244		#245		Cascade ON/OFF	Subsection 8.2.64

6.10 AUTO/MANUAL mode changeover

6.10.1 AUTO mode and MANUAL mode

The mode can be changed over between "AUTO mode" and "MANUAL mode".

The AUTO mode is selected when "K0" is written to the AUTO/MANUAL mode changeover buffer memory.

The MANUAL mode is selected when "K1" is written to the AUTO/MANUAL mode changeover buffer memory.

Set the control mode to 0 to 3 (PID control) for performing manual mode.

In the MANUAL mode, b13 of the event becomes "1" to notify the MANUAL mode.

0.25 sec is required to change over the mode.

During changeover, the balance-less, bump-less function is actuated.

→ For details on the control mode switch, refer to Section 6.2.

→ For details on the balance-less, bump-less function, refer to Subsection 6.10.2.

- AUTO mode

In the AUTO mode, the measured value (PV) or external input value is compared with the set value (SV), and the control output (MV) is given by PID arithmetic operation.

The AUTO mode is selected at shipment.

In the AUTO mode, the MANUAL output set value is always set to the control output value (MV).

- MANUAL mode

By changing the MANUAL output set value, the output value can be fixed to an arbitrary value.

The actual output value is within the range from the output limiter lower limit to the output limiter upper limit.

The output change ratio limiter setting is valid.

The MANUAL output set value can be changed while b13 of the event is ON.

Associated buffer memory

BFM No.				Description	Reference
CH1	CH2	CH3	CH4		
#1	#2	#3	#4	Event (b13 MANUAL mode transition completed flag)	Subsection 8.2.2
#25	#26	#27	#28	External input value	Subsection 8.2.8
#54	#94	#134	#174	AUTO/MANUAL mode changeover	Subsection 8.2.18
#55	#95	#135	#175	MANUAL output set value	Subsection 8.2.19
#64	#104	#144	#184	Output limiter upper limit/Heating upper output limiter setting	Subsection 8.2.28
#65	#105	#145	#185	Output limiter lower limit	Subsection 8.2.29
#67	#107	#147	#187	Output change ratio limiter	Subsection 8.2.31

Caution

- The MANUAL mode is not available while heating/cooling PID control is being performed.
- Even in MANUAL mode, the temperature alarm function is functional.

6.10.2 Balance-less, bump-less function

The balance-less, bump-less function prevents overload caused by drastic change in the control output value (MV) when the mode is changed over from AUTO mode to MANUAL mode (or from MANUAL mode to AUTO mode).

The balance-less, bump-less function is automatically activated when the AUTO mode is switched to the MANUAL mode, and does not require setting.

- Operation performed when the mode is changed over from AUTO mode to MANUAL mode
The control output value (MV) in the AUTO mode continues to be effective.
- Operation performed when the mode is changed over from MANUAL mode to AUTO mode
The control output value (MV) is changed over to a value automatically calculated based on the set value (SV).

Example of operation

Control output value (MV)

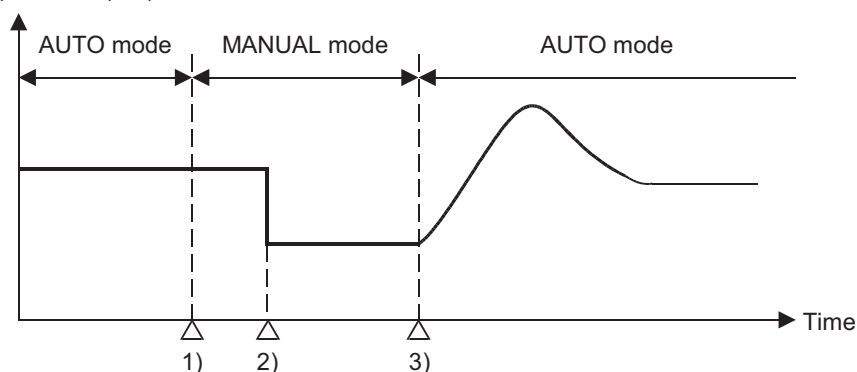

- 1) The mode is changed over from AUTO mode to MANUAL mode.
However, the control output value (MV) follows the control output value (MV) in the AUTO mode.
- 2) The control output value (MV) is manually changed.
- 3) Operation performed when the mode is changed over from AUTO mode to MANUAL mode.
The control output value (MV) becomes a value automatically calculated based on the set value (SV).

Associated buffer memory

BFM No.				Description	Reference
CH1	CH2	CH3	CH4		
#1	#2	#3	#4	Event (b13 MANUAL mode transition completed flag)	Subsection 8.2.2
#54	#94	#134	#174	AUTO/MANUAL mode changeover	Subsection 8.2.18
#55	#95	#135	#175	MANUAL output set value	Subsection 8.2.19

1 Introduction
2 Specification
3 System Configuration
4 Installation
5 Wiring
6 Introduction of Functions
7 Alarm
8 Buffer Memory
9 Program Examples
10 Troubleshooting

6.11 Heater Disconnection Alarm Function (HBA)

6.11.1 Heater disconnection alarm function

The heater disconnection alarm function detects the current flowing in the load using a current detector (CT), it compares the detected value (heater current measured value) with the current value set for heater disconnection alarm, and issues an alarm when the measured value is more than or less than the current set value for the heater disconnection alarm.

The heater current measured value can be measured using buffer memories.

By setting the number of times of heater disconnection alarm delay, it is possible to issue an alarm when abnormalities in the heater current measured value exceed the preset number of times.

→ For details on the number of times of heater disconnection alarm delay, refer to Subsection 6.11.2.

Example of connection

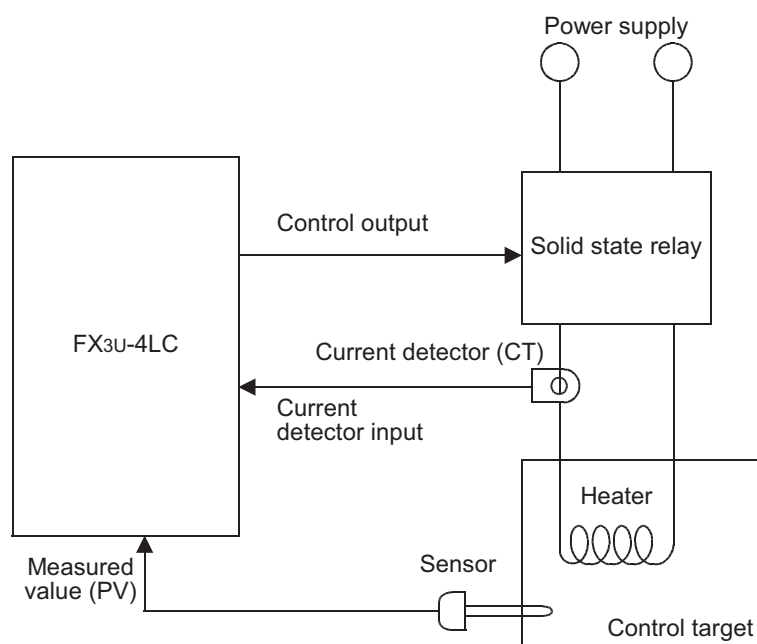

Operation

When either of the following occurs, it is considered as a cause for the heater disconnection alarm status and b9 of the event buffer memory turns ON.

- When the heater current does not flow (Caused by heater disconnection, error in operating machine, etc.)
When the reference current measured value is equivalent to or less than the current set value for the heater disconnection alarm while the control output is ON, an alarm is issued.
However, if the control output ON time is 0.22 sec or less, heater disconnection alarm function is not issued.
- When the heater current does not turn OFF (Caused by a molten relay, etc.)
When the reference heater current measured value is more than the current set value for the heater disconnection alarm while the control output is OFF, an alarm is issued.
However, if the control output OFF time is 0.22 sec or less, heater disconnection alarm function is not issued.

Current detector (CT)

Type	Current measurement range
CTL-12-S36-8	0.0 to 100.0A
CTL-12-S56-10	0.0 to 100.0A
CTL-6-P-H	0.0 to 30.0A

Manufactured by U.R.D. Co., Ltd.

Associated buffer memory

BFM No.				Description	Reference
CH1	CH2	CH3	CH4		
#1	#2	#3	#4	Event (b9 Heater disconnection alarm)	Subsection 8.2.2
#21	#22	#23	#24	Heater current measured value	Subsection 8.2.7
#53	#93	#133	#173	Heater disconnection alarm set value	Subsection 8.2.17
#235				Number of times of heater disconnection alarm delay/ Number of times of current error detection when output is OFF delay	Subsection 8.2.57
#238				CT monitor method switch	Subsection 8.2.60
#239				CT ratio setting	Subsection 8.2.61

Caution

- Set a value lower than the actual heater current as the heater disconnection alarm set value.
- When external output is selected in the control mode switch function, the heater disconnection alarm function is disabled. Heater current measured value is always set to "0".
- When the set value is "0", the heater disconnection alarm function is turned OFF. However, when turned OFF, it is possible to monitor the heater current measured value.

6.11.2 Number of times of heater disconnection alarm delay

Set the number of times of delay for detecting heater disconnection alarm or current abnormality while the output is OFF.

If abnormalities occur exceeding the preset number of times in the heater current measured value or current value while the output is OFF, an alarm is issued.

The sampling period is 500ms for the heater current measured value and the current value while the output is OFF.

Associated buffer memory

BFM No.				Description	Reference
CH1	CH2	CH3	CH4		
#1	#2	#3	#4	Event (b9 Heater disconnection alarm)	Subsection 8.2.2
#21	#22	#23	#24	Heater current measured value	Subsection 8.2.7
#53	#93	#133	#173	Heater disconnection alarm set value	Subsection 8.2.17
#235				Number of times of heater disconnection alarm delay/ Number of times of current error detection when output is OFF delay	Subsection 8.2.57

1

Introduction

2

Specification

3

System Configuration

4

Installation

5

Wiring

6

Introduction of Functions

7

Alarm

8

Buffer Memory

9

Program Examples

10

Troubleshooting

6.12 Loop Breaking Alarm Function (LBA)

6.12.1 Loop breaking alarm function

The loop breaking alarm function starts to detect the variation of the measured value (PV), at every loop breaking alarm judgment time when the output becomes more than 100% (or the output limiter upper limit) or less than 0% (or the output limiter lower limit), then sets to ON the loop breaking alarm (b8) when judging that there is an abnormality in the control loop.

The loop breaking alarm function is enabled when the loop breaking alarm judgment time is set.

It is possible to set a dead zone that is excluded from loop breaking detection.

→ For details on the loop breaking alarm judgement time, refer to Subsection 8.2.42.

→ For details on the loop breaking alarm dead zone, refer to Subsection 6.12.2.

Operation

Loop breaking alarm is issued in the following cases.

- PID control (reverse operation)

When output is less than 0% or output limiter lower limit	When measured value (PV) does not decrease at least by loop breaking change criteria*1 within loop breaking alarm judgement time, an alarm is issued.
When output is more than 100% or output limiter upper limit	When measured value (PV) does not increase at least by loop breaking change criteria*1 within loop breaking alarm judgement time, an alarm is issued.

- PID control (normal operation)

When output is less than 0% or output limiter lower limit	When measured value (PV) does not decrease at least by loop breaking change criteria*1 within loop breaking alarm judgement time, an alarm is issued.
When output is more than 100% or output limiter upper limit	When measured value (PV) does not increase at least by loop breaking change criteria*1 within loop breaking alarm judgement time, an alarm is issued.

- *1. The variation range for loop breaking alarm judgment is fixed as follows, and cannot be changed.
- 2.0°C for internal temperature input
 - 0.2% of the scaling span for internal micro voltage input
 - 0.2% of the external input span for external input

- In heating/cooling PID control
The loop breaking alarm function is disabled.

Abnormality targets

- Abnormality in control target
Heater disconnection/short-circuit, lack of power supply, wiring mistake, etc.
- Abnormality in sensor
Sensor disconnection, short-circuit, etc.
- Abnormality in operating machine
Molten relay, wiring mistake, etc.
- Abnormality in output circuit
Molten relay inside instrument, etc.
- Abnormality in input circuit
No change in the measured value (PV) even after input has changed

Associated buffer memory

BFM No.				Description	Reference
CH1	CH2	CH3	CH4		
#1	#2	#3	#4	Event (b8 Loop breaking alarm)	Subsection 8.2.2
#5	#6	#7	#8	Measured value (PV)	Subsection 8.2.3
#64	#104	#144	#184	Output limiter upper limit/Heating upper output limiter setting	Subsection 8.2.28
#65	#105	#145	#185	Output limiter lower limit	Subsection 8.2.29
#78	#118	#158	#198	Loop breaking alarm judgement time	Subsection 8.2.42
#79	#119	#159	#199	Loop breaking alarm dead zone	Subsection 8.2.43

Caution

- The loop breaking alarm function judges abnormalities in the control loop, but cannot detect positions in which abnormalities occur. Check each part of the control system in turn.
- When the AT (auto tuning) function is completed, the loop breaking alarm judgement time is automatically set to the integral time result multiplied by 2.
- Set the time in which the measured increments changes by 2.0°C or 0.2% of the span or longer as the loop breaking alarm judgment time.
If the loop breaking alarm judgement time is too short or is not suitable to control targets, the loop breaking alarm may repeatedly turn on and off or may not turn ON. In such a case, change the loop breaking alarm judgement time in accordance with the situation.
- In heating/cooling PID control, the loop breaking alarm function is disabled.
- While AT (auto tuning) is performed, the loop breaking alarm function is disabled.
- When the set value is "0", the loop breaking alarm function is disabled.
- When the measured value (PV) is within the loop breaking alarm dead zone, alarm is not issued even if the alarm issue condition is satisfied.
- In heating/cooling PID control, the loop breaking alarm dead zone is invalid.

1

Introduction

2

Specification

3

System Configuration

4

Installation

5

Wiring

6

Introduction of Functions

7

Alarm

8

Buffer Memory

9

Program Examples

10

Troubleshooting

6.12.2 Loop breaking alarm dead zone (LBD)

Set the loop breaking alarm judgement time.

The loop breaking alarm function may issue alarms caused by disturbances (effect of another heat source, etc.) even if there is no abnormality in the control system. In order to prevent such alarms, by setting the loop breaking alarm dead zone, the region in which the alarm function is disabled (non-alarm status region) can be set.

For example, if the loop breaking alarm dead zone is set to "10 °C", 10 °C above the set value (SV) and 10°C below the set value (SV) are treated as the non-alarm status region (width of 20 °C in total).

Example of operation

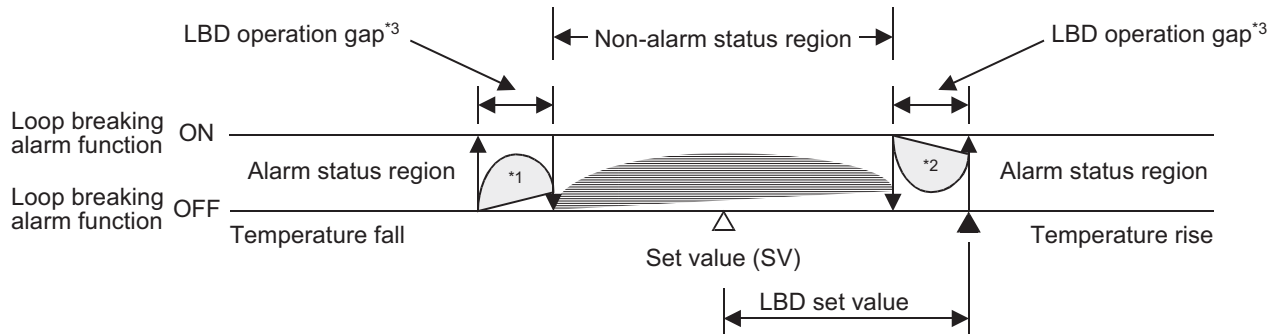

- *1. While the temperature is rising : Alarm status region
While the temperature is decreasing : Non-alarm status region
- *2. While the temperature is rising : Non-alarm status region
While the temperature is decreasing : Alarm status region
- *3. Loop breaking alarm dead zone operation gap
0.8°C for internal temperature input
0.8% of the scaling span for internal micro voltage input
0.8% of the external input span for external input

Associated buffer memory

BFM No.				Description	Reference
CH1	CH2	CH3	CH4		
#1	#2	#3	#4	Event (b8 Loop breaking alarm)	Subsection 8.2.2
#5	#6	#7	#8	Measured value (PV)	Subsection 8.2.3
#48	#88	#128	#168	Set value (SV)	Subsection 8.2.15
#64	#104	#144	#184	Output limiter upper limit/Heating upper output limiter setting	Subsection 8.2.28
#65	#105	#145	#185	Output limiter lower limit	Subsection 8.2.29
#78	#118	#158	#198	Loop breaking alarm judgement time	Subsection 8.2.42
#79	#119	#159	#199	Loop breaking alarm dead zone	Subsection 8.2.43

Caution

- While the measured value (PV) is located within the non-alarm region, alarm is not issued even if the alarm condition is satisfied.
- In heating/cooling PID control, the loop breaking alarm dead zone is invalid.

7. Alarm

The 4LC is equipped with 14 types of alarms. Four types of alarms (alarm 1 to alarm 4) are available in each channel in accordance with the application.

Set the alarm type by writing the alarm mode (0 to 14) to the alarm mode setting buffer memories for alarms 1 to 4 (each channel).

Values of alarms 1 to 4 can be set using the alarm set value buffer memories, and the alarm status can be checked in the status of alarm bits (b4 to b7) for alarms 1 to 4 of the event buffer memory.

The alarm dead zone and number of times of alarm delay can be set for the alarm function.

By setting the alarm dead zone, it is possible to prevent repetition of alarm status and non-alarm status.

By setting the number of times of alarm delay, alarm can be issued when the number of times of input sampling exceeds the preset number of times of alarm delay.

→ For details on the event, refer to Subsection 8.2.2.

→ For details on the alarm setting value, refer to Subsection 8.2.16.

→ For details on the alarm mode setting, refer to Subsection 8.2.53.

→ For details on the alarm dead zone setting, refer to Section 7.3 or Subsection 8.2.55.

→ For details on the number of times of alarm delay, refer to Section 7.4 or Subsection 8.2.56.

7.1 Alarm List

The list below shows alarms provided in the 4LC.

→ For details on the alarm, refer to Section 7.2.

Alarm mode	Alarm type	Description	Setting range	Reference
0	Alarm function OFF	Alarm function is disabled.	-	-
1	Upper limit input value alarm	When measured value (PV) is more than alarm set value, an alarm is issued.	Input range ^{*1}	Subsection 7.2.1
2	Lower limit input value alarm	When measured value (PV) is less than alarm set value, an alarm is issued.	Input range ^{*1}	Subsection 7.2.2
3	Upper limit deviation alarm	When deviation (= Measured value (PV) - Set value (SV)) is more than alarm set value, an alarm is issued.	-Span to +Span ^{*2}	Subsection 7.2.3
4	Lower limit deviation alarm	When deviation (= Measured value (PV) - Set value (SV)) is less than alarm set value, an alarm is issued.	-Span to +Span ^{*2}	Subsection 7.2.4
5	Upper/lower limit deviation	When absolute deviation (= Measured value (PV) - Set value (SV)) is more than alarm set value, an alarm is issued.	0 to +Span ^{*2}	Subsection 7.2.5
6	Range alarm	When absolute deviation (= Measured value (PV) - Set value (SV)) is less than alarm set value, an alarm is issued.	0 to +Span ^{*2}	Subsection 7.2.6
7	Upper limit input value alarm with wait	When measured value (PV) is more than alarm set value, an alarm is issued. However, when control is started the measured value is ignored.	Input range ^{*1}	Subsection 7.2.7
8	Lower limit input value alarm with wait	When measured value (PV) is less than alarm set value, an alarm is issued. However, when control is started the measured value is ignored.	Input range ^{*1}	Subsection 7.2.7
9	Upper limit deviation value alarm with wait	When deviation (= Measured value (PV) - Set value (SV)) is more than alarm set value, an alarm is issued. However, when control is started the measured value is ignored.	-Span to +Span ^{*2}	Subsection 7.2.7
10	Lower limit deviation value alarm with wait	When deviation (= Measured value (PV) - Set value (SV)) is less than alarm set value, an alarm is issued. However, when control is started the measured value is ignored.	-Span to +Span ^{*2}	Subsection 7.2.7
11	Upper/lower limit deviation value alarm with wait	When absolute deviation (= Measured value (PV) - Set value (SV)) is more than alarm set value, an alarm is issued. However, when control is started the measured value is ignored.	0 to +Span ^{*2}	Subsection 7.2.7
12	Upper limit deviation value alarm with re-wait	When deviation (= Measured value (PV) - Set value (SV)) is more than alarm set value, an alarm is issued. However, when control is started and when set value is changed the measured value is ignored.	-Span to +Span ^{*2}	Subsection 7.2.8

Alarm mode	Alarm type	Description	Setting range	Reference
13	Lower limit deviation value alarm with re-wait	When deviation (= Measured value (PV) - Set value (SV)) is less than alarm set value, an alarm is issued. However, when control is started and when set value is changed the measured value is ignored.	-Span to +Span ^{*2}	Subsection 7.2.8
14	Upper/lower limit deviation value alarm with re-wait	When absolute deviation (= Measured value (PV) - Set value (SV)) is more than alarm set value, an alarm is issued. However, when control is started and when set value is changed the measured value is ignored.	0 to +Span ^{*2}	Subsection 7.2.8

- *1. Input range for internal temperature input
Scaling range for internal micro voltage input
External input range for external input
- *2. Input span for internal temperature input
Scaling span for internal micro voltage input
External input span for external input

7.2 Alarm Functions

The alarm functions issue an alarm when the measured value (PV) or deviation [Measured value (PV) - Set value (SV)] reaches the alarm set value.

The alarm status can be checked in the status of bits for alarms 1 to 4 of the event buffer memory.

For settings of alarm functions, refer to the following.

- For details on the event, refer to Subsection 8.2.2.
- For details on the measured value (PV), refer to Subsection 8.2.3.
- For details on the set value (SV), refer to Subsection 8.2.15.
- For details on the alarm setting value, refer to Subsection 8.2.16.
- For details on the alarm mode setting, refer to Subsection 8.2.53.

Caution

- In cascade control, the alarm waiting operation is disabled on the slave channel side when the set value (SV) is changed.
- When the setting change ratio limiter is set to any value other than "0", the alarm waiting operation is disabled when the set value (SV) is changed.

7.2.1 Upper limit input value alarm

When the measured value (PV) is more than the alarm set value, an alarm is issued.

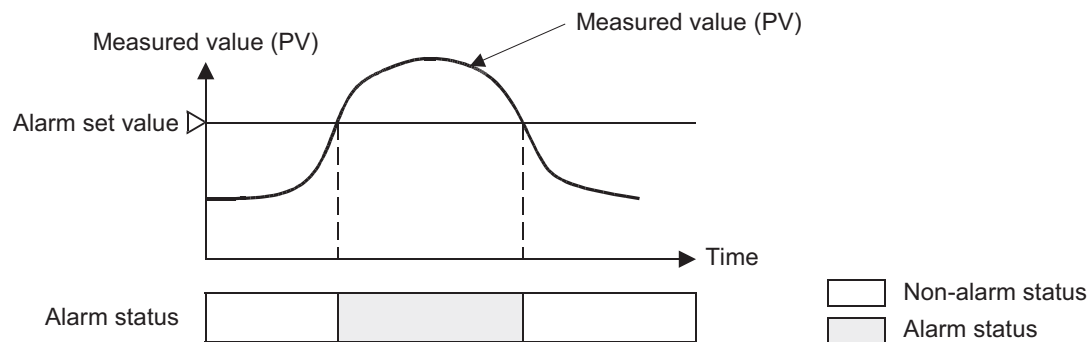

7.2.2 Lower limit input value alarm

When the measured value (PV) is less than the alarm set value, an alarm is issued.

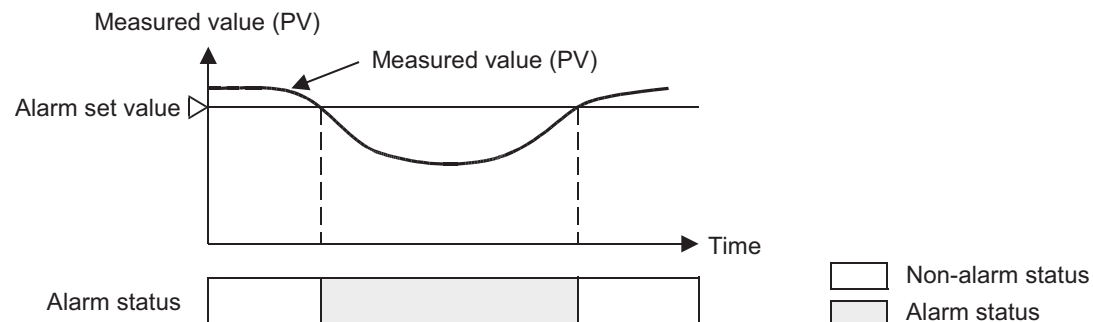

7.2.3 Upper limit deviation alarm

When the deviation (= Measured value (PV) - Set value (SV)) is more than the alarm set value, an alarm is issued.

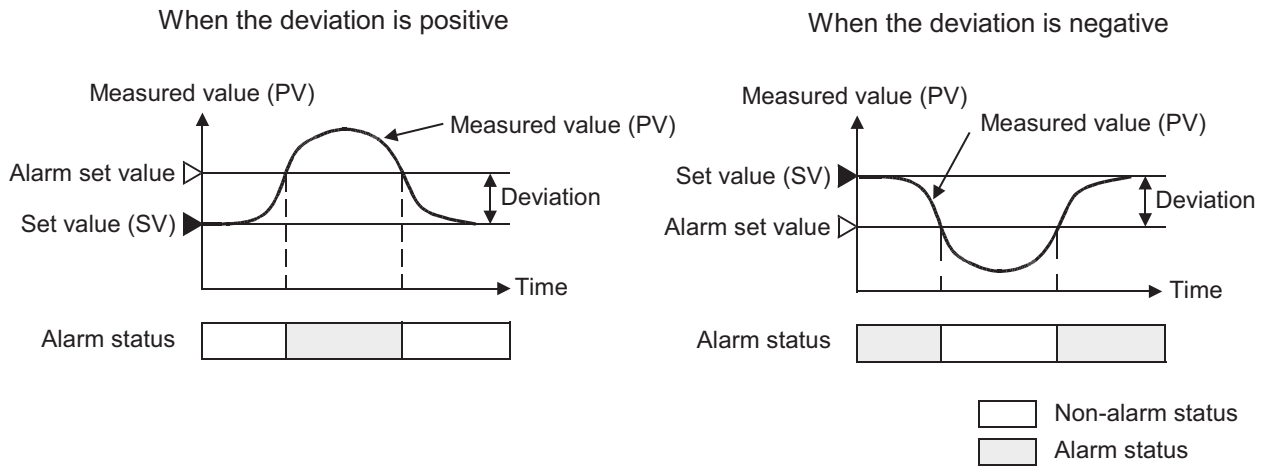

7.2.4 Lower limit deviation alarm

When the deviation (= Measured value (PV) - Set value (SV)) is less than the alarm set value, an alarm is issued.

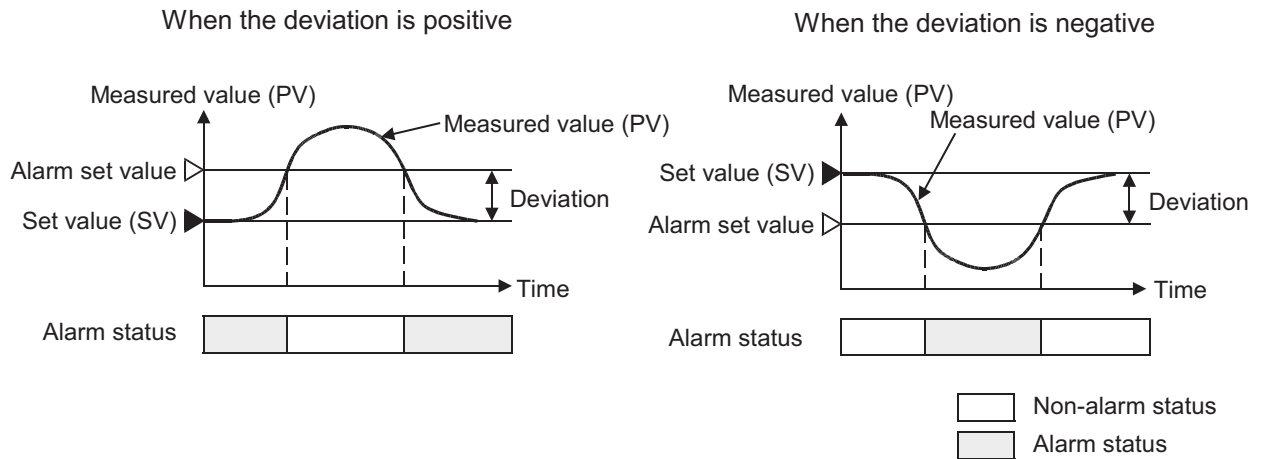

7.2.5 Upper/lower limit deviation

When the absolute deviation (= Measured value (PV) - Set value (SV)) is more than the alarm set value, an alarm is issued.

For example, if the alarm set value is "+10 °C", an alarm is issued when the measured value (PV) is outside the range from "set value (SV) +10 °C" to "set value (SV) -10 °C".

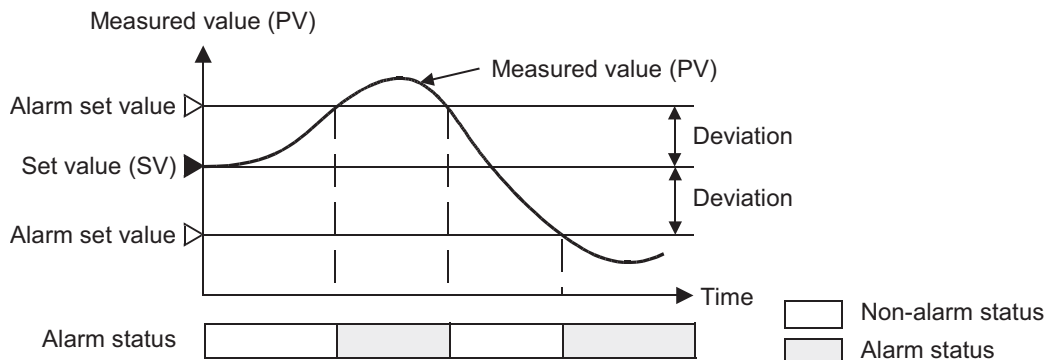

7.2.6 Range alarm

When the absolute deviation (= Measured value (PV) - Set value (SV)) is less than the alarm set value, an alarm is issued.

For example, if the alarm set value is "+10 °C", an alarm is issued when the measured value (PV) is inside the range from "set value (SV) + 10 °C" to "set value (SV) - 10 °C".

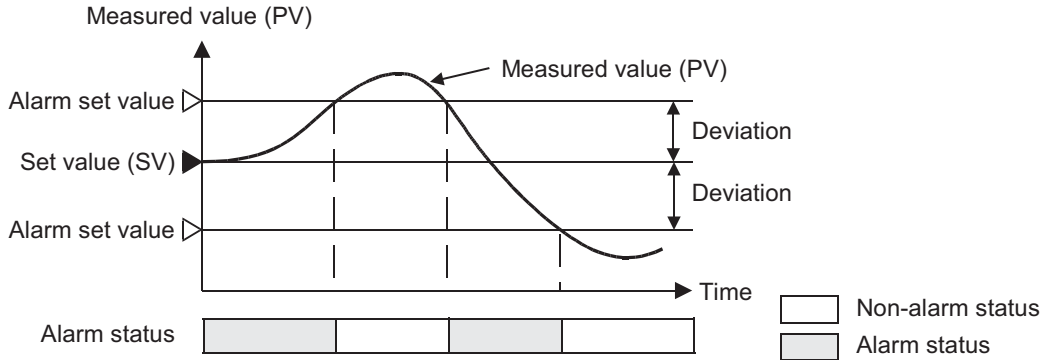

7.2.7 Alarm wait operation

The wait operation ignores the alarm status of the measured value (PV) when control is started, and disables the alarm function until the measured value (PV) enters the alarm region after the wait period has ended.

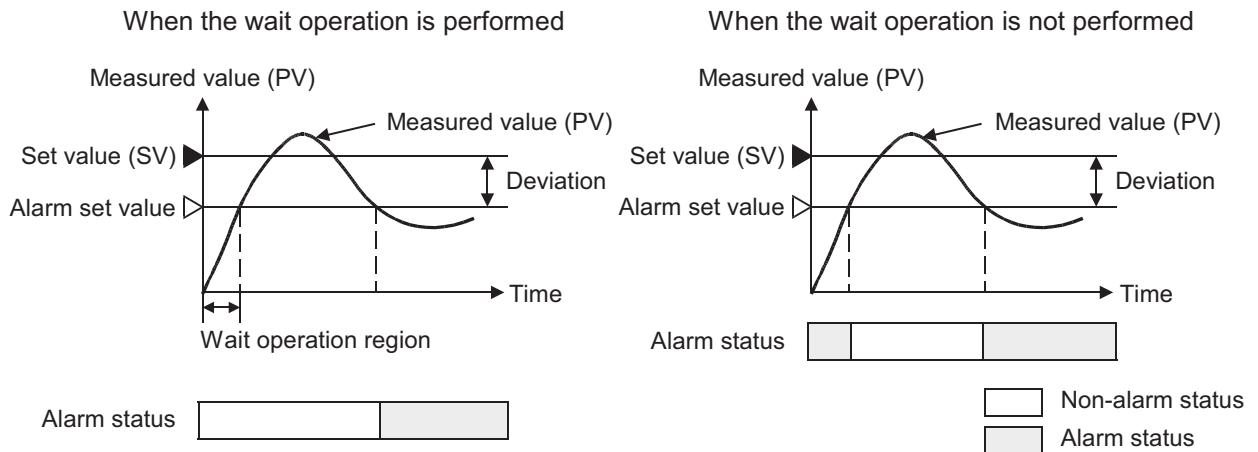

1 Introduction
 2 Specification
 3 System Configuration
 4 Installation
 5 Wiring
 6 Introduction of Functions
 7 Alarm
 8 Buffer Memory
 9 Program Examples
 10 Troubleshooting

7.2.8 Alarm re-wait operation

The alarm re-wait operation ignores the alarm status of the measured value (PV) when control is started, and disables the alarm function until the measured value (PV) enters the alarm region after the wait period has ended.

When the set value (SV) is changed, the measured value (PV) for deviation alarm changes accordingly. At this time, even if the measured value (PV) becomes the alarm status, the alarm re-wait function ignores it again and disables the alarm function until the measured value (PV) goes out of the alarm status again.

Re-wait operation

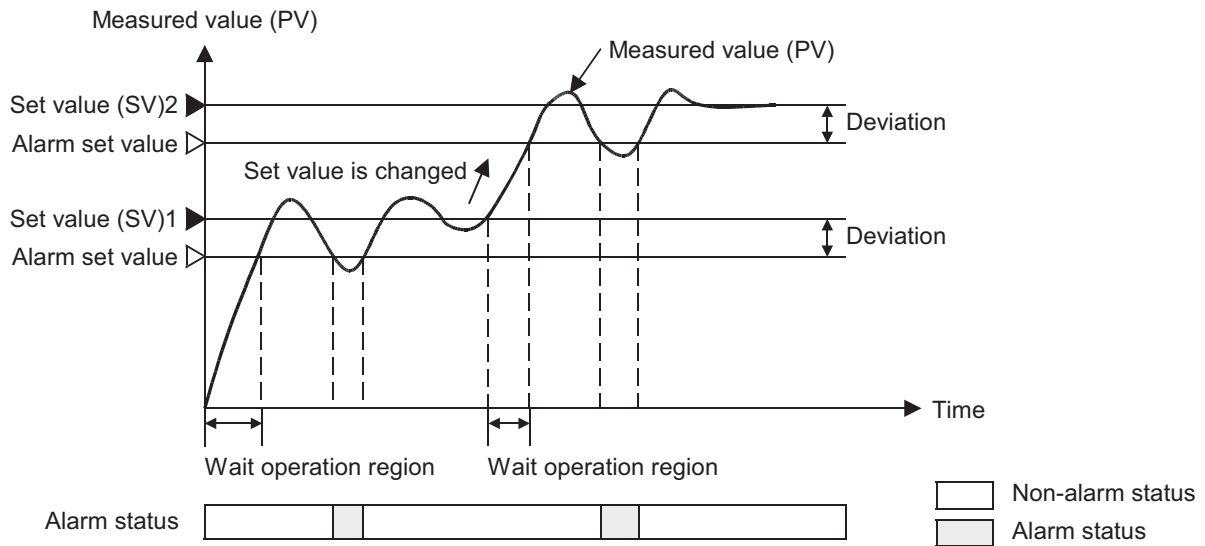

7.3 Alarm Dead Zone Setting

In BFM#233, set the dead zone of alarms 1 to 4.

This setting is applied to all of alarms 1 to 4.

When the measured value (PV) is near the alarm set value, the alarm status and the non-alarm status may be repeated by fluctuation in inputs. In order to cope with such a case, by setting the alarm dead zone, repeating of the alarm status and the non-alarm status can be prevented.

→ For details on the alarm dead band setting, refer to Subsection 8.2.55.

Upper limit input value alarm, Upper limit deviation alarm

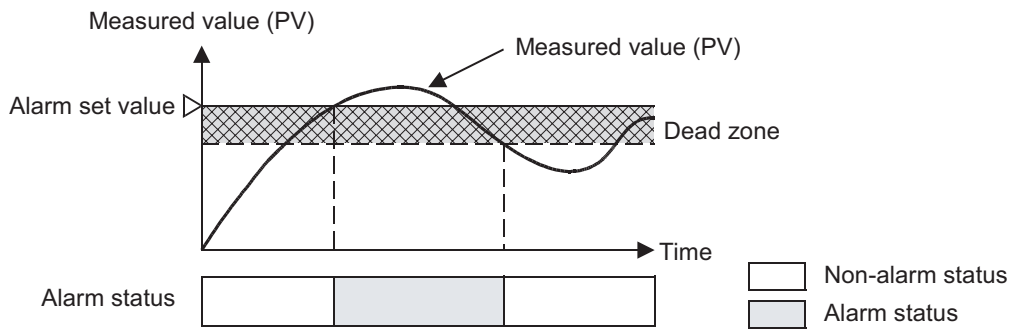

Lower limit input value alarm, Lower limit deviation alarm

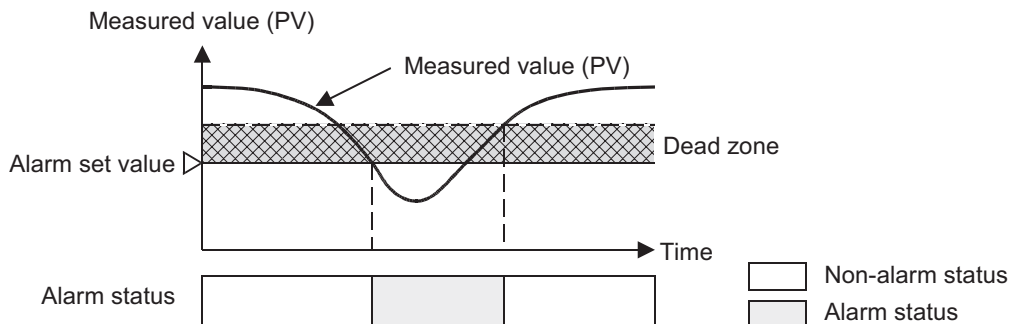

Upper/lower limit deviation

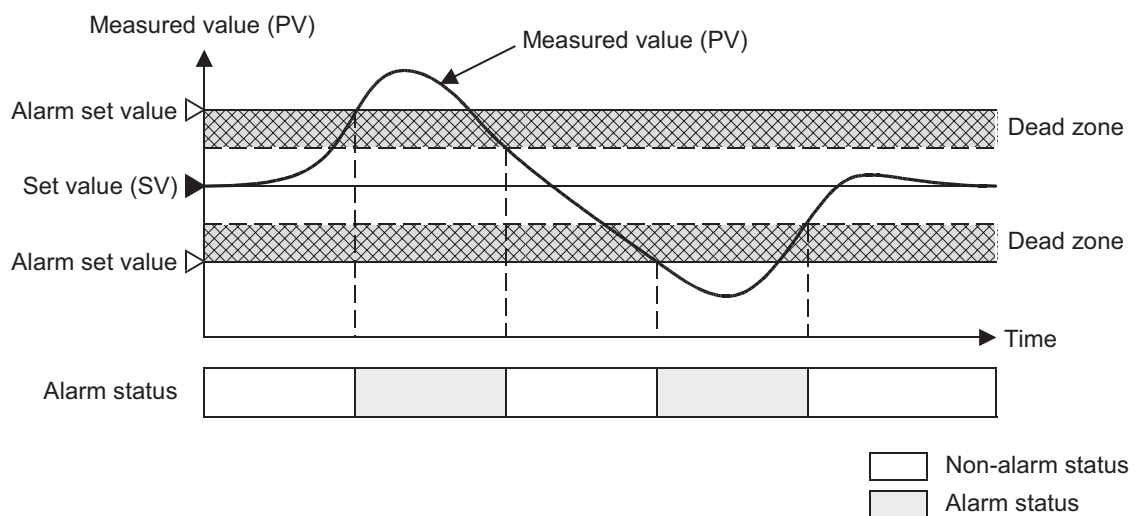

1 Introduction
2 Specification
3 System Configuration
4 Installation
5 Wiring
6 Introduction of Functions
7 Alarm
8 Buffer Memory
9 Program Examples
10 Troubleshooting

7.4 Number of Times of Alarm Delay

In BFM#234, set the number of alarm delays.

This setting is applied to all alarms 1 to 4.

The alarm delay function keeps the non-alarm status until the number of input samples exceeds the number of alarm delays, after the deviation between the measured value (PV) and the set value (SV) reaches the alarm set value.

If the deviation remains in the alarm range until the number of input samples exceeds the number of alarm delays, an alarm is issued.

→ For details on the alarm delay count, refer to Subsection 8.2.56.

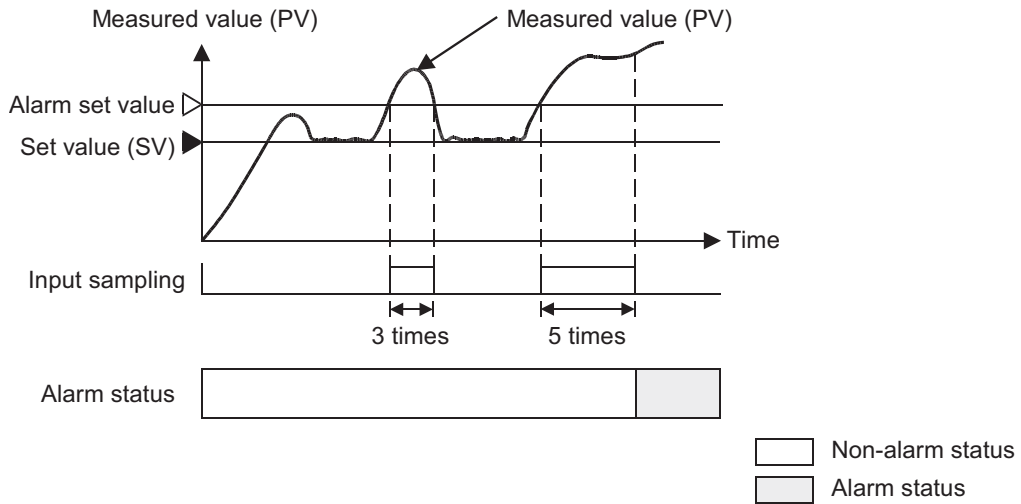

8. Buffer Memory

Each setting and alarm in the 4LC is written from or read to the PLC main unit through buffer memories. To read or write to the 4LC buffer memory, use FROM/TO instructions or specify buffer memory values directly.

Each buffer memory consists of 16 bits. Use the FROM/TO instructions (or direct specification of buffer memory) in the 16-bit format.

→ For details of FROM/TO instructions (or direct specification of buffer memory), refer to the Programming Manual.

Caution

- If a value is written by mistake to a buffer memory used only for read, the written value is ignored. And 250ms later, the buffer memory is overwritten with a correct value.
- If a value outside the allowable set range is written to a buffer memory used both for read and write, the set value range error (b1) of the flag (BFM#0) turns ON. The buffer memory number in which an error has been generated is stored in a set value range error address (BFM#252). And the buffer memory in which the set value range error has occurred is controlled with the upper limit or the lower limit of the allowable set range.

8.1 Buffer Memory List

The table below provides a brief description and reference information for the 4LC buffer memory.

→ For details on the buffer memory, refer to Section 8.2.

The "Remarks" column in the buffer memory list indicates the following.

R/W : Read or Write

R : Read only

✓ : Data can be backed-up using the set value backup command (BFM#254).

● : Handling numbers containing decimal places.

The set value should be the actual value multiplied by ten.

The set value should be the actual value multiplied by "100" for the sensor correction value setting buffer memories (BFM#68, BFM#108, BFM#148 and BFM#188), and multiplied by "1000" for the cascade gain buffer memories (BFM#246 and BFM#247).

△ : Handling integers or numbers containing decimal places according to the input range (setting of BFM#208, #214, #220 and #226).

When handling numbers containing decimal places, multiply the set value by ten.

BFM No.				Name	Description/set range	Initial value	Remarks		
CH1	CH2	CH3	CH4						
#0				Flag	Refer to Subsection 8.2.1.	-	R	-	-
#1	#2	#3	#4	Event	Refer to Subsection 8.2.2.	-	R	-	-
#5	#6	#7	#8	Measured value (PV)	±5% of input range	-	R	-	△
#9	#10	#11	#12	PID control	Control output value (MV) monitor	-	R	-	●
				Heating/cooling PID control	Heating control output value (MV) monitor				
#13	#14	#15	#16	PID control	Not used	-	R	-	●
				Heating/cooling PID control	Cooling control output value (MV) monitor				
#17	#18	#19	#20	Control output flag	Refer to Subsection 8.2.6.	-	R	-	-
#21	#22	#23	#24	Heater current measured value	0 to 1050 (0.0 to 105.0A)	-	R	-	●
#25	#26	#27	#28	External input value	-32768 to +32767	0	R/W	-	-
#29				Control start/stop changeover	0 : Stops control 1 : Starts control	0	R/W	-	-
#30				FX Series model code	K2090	2090	R	-	-
#31				Not used	-	-	-	-	-

BFM No.				Name	Description/set range	Initial value	Remarks			
CH1	CH2	CH3	CH4							
#32	#33	#34	#35	PID control	External output value monitor	External output range lower limit to External output range upper limit	0	R	-	-
				Heating/cooling PID control	Heating external output value monitor					
#36	#37	#38	#39	PID control	Not used	-	0	-	-	-
				Heating/cooling PID control	Cooling external output value monitor	External output range lower limit to External input range upper limit	0	R	-	-
#40	#41	#42	#43	Set value monitor		Setting limiter lower limit to Setting limiter upper limit	0	R	-	-
#44	#45	#46	#47	Control mode monitor		Refer to Subsection 8.2.14.	0	R	-	-
#48	#88	#128	#168	Set value (SV)		Setting limiter lower limit to Setting limiter upper limit	0	R/W	✓	△
#49	#89	#129	#169	Alarm 1 set value		Allowable set range varies depending on alarm mode and input type setting.	0	R/W	✓	△
#50	#90	#130	#170	Alarm 2 set value					✓	△
#51	#91	#131	#171	Alarm 3 set value					✓	△
#52	#92	#132	#172	Alarm 4 set value					✓	△
#53	#93	#133	#173	Heater disconnection alarm set value		0 to 1000 (0.0 to 100.0A)	0	R/W	✓	●
#54	#94	#134	#174	AUTO/MANUAL mode changeover		0 : AUTO mode 1 : MANUAL mode	0	R/W	✓	-
#55	#95	#135	#175	MANUAL output set value		-50 to +1050 (-5.0 to +105.0%)	-50	R/W	-	●
#56	#96	#136	#176	AT (auto tuning) execution command		0 : Stops Auto turning 1 : Performs Auto turning	0	R/W	✓	-
#57	#97	#137	#177	Operation mode		0 : Not used 1 : Monitor 2 : Monitor + Alarm 3 : Monitor + Alarm + Control	3	R/W	✓	-
#58	#98	#138	#178	PID control	Proportional band (P)	0 to 10000 (0.0 to 1000.0% of span)	30	R/W	✓	●
				Heating/cooling PID control	Heating proportional band (P)					
#59	#99	#139	#179	PID control	Not used	-	0	-	-	-
				Heating/cooling PID control	Cooling proportional band (P)	1 to 10000 (0.1 to 1000.0% of span)	30	R/W	✓	●
#60	#100	#140	#180	Integral time (I)		0 to 3600 sec.	240	R/W	✓	-
#61	#101	#141	#181	Derivative time (D)		0 to 3600 sec.	60	R/W	✓	-
#62	#102	#142	#182	Control response parameter		0 : Slow 1 : Medium 2 : Fast	0	R/W	✓	-
#63	#103	#143	#183	PID control	Not used	-	0	-	-	-
				Heating/cooling PID control	Overlap/Dead band	-100 to 100 (-10.0 to 10.0% of span)	0	R/W	✓	-
#64	#104	#144	#184	PID control	Output limiter upper limit	Output limiter lower limit + 1 to 1050 (to 105.0%)	1000	R/W	✓	●
				Heating/cooling PID control	Heating output limiter upper limit	0 to 1050 (0.0 to 105.0%)	1000			
#65	#105	#145	#185	PID control	Output limiter lower limit	-50 to Output limiter upper limit - 1 (-5.0% to)	0	R/W	✓	●
				Heating/cooling PID control	Not used	-	0			
#66	#106	#146	#186	PID control	Not used	-	0	R/W	✓	●
				Heating/cooling PID control	Cooling output limiter upper limit	0 to 1050 (0.0 to 105.0%)	1000			
#67	#107	#147	#187	PID control	Output change ratio limiter	0 to 1000 (0.0 to 100.0%/sec.)	0	R/W	✓	●
				Heating/cooling PID control	Not used	-	0			
#68	#108	#148	#188	Sensor correction value setting		-5000 to +5000 (-50.00 to +50.00% of span)	0	R/W	✓	●

BFM No.				Name	Description/set range	Initial value	Remarks			
CH1	CH2	CH3	CH4							
#69	#109	#149	#189	Adjustment sensitivity (dead zone) setting		1 to 100 (0.1 to 10.0% of span)	10	R/W	✓	●
#70	#110	#150	#190	PID control	Control output cycle setting	5 to 1000 (0.5 to 100.0 sec.)	300	R/W	✓	●
				Heating/cooling PID control	Heating control output period setting		300			
#71	#111	#151	#191	PID control	Not used	-	0	-	-	-
				Heating/cooling PID control	Cooling control output period setting	5 to 1000 (0.5 to 100.0 sec.)	300	R/W	✓	●
#72	#112	#152	#192	Primary delay digital filter setting		0 to 100 sec.	0	R/W	✓	-
#73	#113	#153	#193	Setting change ratio limiter		0 to 1000 (0.0 to 100.0% of span)	0	R/W	✓	●
#74	#114	#154	#194	AT (Auto tuning) bias		±input span	0	R/W	✓	△
#75	#115	#155	#195	PID control	Normal/reverse operation selection	0 : Normal operation 1 : Reverse operation	1	R/W	✓	-
				Heating/cooling PID control	Not used	-	0	-	-	-
#76	#116	#156	#196	Setting limiter upper limit		Setting limiter lower limit + 1 to Input range upper limit	1300	R/W	✓	△
#77	#117	#157	#197	Setting limiter lower limit		Input range lower limit to Setting limiter upper limit - 1	-100	R/W	✓	△
#78	#118	#158	#198	Loop breaking alarm judgement time		0 to 7200 sec.	480	R/W	✓	-
#79	#119	#159	#199	Loop breaking alarm dead zone		0 to input span	0	R/W	✓	△
#80	#120	#160	#200	Micro voltage input scaling upper limit		-20000 to +20000 (Reverse between upper limit and lower limit is not allowed. Span should be 20000 or less.)	10000	R/W	✓	-
#81	#121	#161	#201	Micro voltage input scaling lower limit		-20000 to +20000 (Reverse between upper limit and lower limit is not allowed. Span should be 20000 or less.)	0	R/W	✓	-
#82	#122	#162	#202	External input range upper limit		-32000 to +32000 (Reverse between upper limit and lower limit is not allowed.)	10000	R/W	✓	-
#83	#123	#163	#203	External input range lower limit		-32000 to +32000 (Reverse between upper limit and lower limit is not allowed.)	0	R/W	✓	-
#84	#124	#164	#204	External output range upper limit		-32000 to +32000 (Reverse between upper limit and lower limit is not allowed.)	10000	R/W	✓	-
#85	#125	#165	#205	External output range lower limit		-32000 to +32000 (Reverse between upper limit and lower limit is not allowed.)	0	R/W	✓	-
#86	#126	#166	#206	Transistor output selection		0 to 7	0	R/W	✓	-
#87	#127	#167	#207	ST (startup tuning) execution command		0 : Stops Startup tuning 1 : Performs Startup tuning	0	R/W	-	-
#208	#214	#220	#226	Input range		0 to 47	2	R/W	✓	-
#209	#215	#221	#227	Alarm 1 alarm mode setting		0 to 14	0	R/W	✓	-
#210	#216	#222	#228	Alarm 2 alarm mode setting			0		✓	-
#211	#217	#223	#229	Alarm 3 alarm mode setting			0		✓	-
#212	#218	#224	#230	Alarm 4 alarm mode setting			0		✓	-
#213	#219	#225	#231	Not used		-	0	-	-	-
#232				PID control	Not used	-	0	-	-	-
				Heating/cooling PID control	cooling method setting	0 : Air cooling type 1 : Water cooling type 2 : Cooling gain linear type	0	R/W	✓	-
#233				Alarm dead band setting		0 to 100 (0.0 to 10.0% of span)	10	R/W	✓	●
#234				Alarm delay count		0 to 30000 times	0	R/W	✓	-
#235				Number of times of heater disconnection alarm delay/Number of times of current error detection when output is OFF delay		3 to 255 times	3	R/W	✓	-
#236				Temperature rise completion range setting		0 to 100 (°C, °F, digit)	10	R/W	✓	-
#237				Temperature rise completion soak time		0 to 3600 sec.	0	R/W	✓	-
#238				CT monitor method switch		0 : Monitors both ON current and OFF current 1 : Monitors only ON current	0	R/W	✓	-
#239				CT ratio setting		1 to 9999	800	R/W	✓	-

1	Introduction
2	Specification
3	System Configuration
4	Installation
5	Wiring
6	Introduction of Functions
7	Alarm
8	Buffer Memory
9	Program Examples
10	Troubleshooting

BFM No.				Name	Description/set range	Initial value	Remarks			
CH1	CH2	CH3	CH4							
#240		#241		Control mode switch	0 to 3 : PID control 4 to 7 : Heating/cooling PID control	0	R/W	✓	-	
#242		#243		PID control	SV tracking selection	0 : Disable 1 : Enable	1	R/W	✓	-
				Heating/cooling PID control	Not used	-	0	-	-	-
#244		#245		PID control	Cascade ON/OFF	0 : Cascade OFF 1 : Cascade ON	0	R/W	-	-
				Heating/cooling PID control	Not used	-	0	-	-	-
#246		#247		PID control	Cascade gain	-10000 to +10000 (-10.000 to +10.000 times)	1000	R/W	✓	●
				Heating/cooling PID control	Not used	-	0	-	-	-
#248		#249		PID control	Cascade bias	-1000 to +1000 (-100.0 to +100.0%)	0	R/W	✓	●
				Heating/cooling PID control	Not used	-	0	-	-	-
#250		#251		Cascade monitor	-32000 to +32000	0	R	-	-	
#252				Set value range error address	0 : Normal 1 to 255 : Setting error address	0	R	-	-	
#253				Error reset command	0 : Performs nothing 1 : Resets errors	0	R/W	-	-	
#254				Set value backup command	0 : Normal 1 : Starts to write EEPROM	0	R/W	-	-	
#255				Initialization command	0 : Performs nothing 1 : Initializes all data 2 : Initializes BFM#48 to #207, #232 and #242 to #247	0	R/W	-	-	
#256 to #862				Not used	-	0	-	-	-	

8.2 Buffer Memory Details

8.2.1 [BFM#0] Flag

The ON/OFF status of each bit indicates the status of the 4LC.

BFM No.				Description	Initial value	R/W	Backup
CH1	CH2	CH3	CH4				
#0				Flag (Refer to the following)	-	R	-

Flag

Bit	Item	Description
b0	Error present	Turns ON when an error among b1 to b10 below has occurred.
b1	Set value range error	Turns ON when data outside set range is written. The buffer memory number in which an error has been generated is stored in a set value range error address (BFM#252).
b2	24V DC power supply error	Turns ON when driving power supply (24V DC) is not supplied. The control output of all channels is turned OFF.
b3	Set value backup error flag	Turns ON when an error has been caused by noise or when a failure has occurred in the 4LC. Turn the power ON again, and check for changes in the state. If no improvement is obtained, consult a Mitsubishi Electric distributor.
b4	CH1 AT/ST abnormal end flag	Turns ON when CH1 AT (auto tuning) or ST (startup tuning) abnormally ends.
b5	CH2 AT/ST abnormal end flag	Turns ON when CH2 AT (auto tuning) or ST (startup tuning) abnormally ends.
b6	CH3 AT/ST abnormal end flag	Turns ON when CH3 AT (auto tuning) or ST (startup tuning) abnormally ends.
b7	CH4 AT/ST abnormal end flag	Turns ON when CH4 AT (auto tuning) or ST (startup tuning) abnormally ends.
b8	Adjustment data error	Turns ON when an error has been caused by noise or when a failure has occurred in the 4LC. The control output of all channels is turned OFF. Turn the power ON again, and check for changes in the state. If no improvement is obtained, consult a Mitsubishi Electric distributor.
b9	Cold contact temperature compensation data error	Turns ON when an error has been caused by noise or when a failure has occurred in the 4LC. The control output of error channels is turned OFF.
b10	A/D converted value error	The error channels can be checked in the status of bits of Event buffer memories (BFM#1 to #4). Turn the power ON again, and check for changes in the state. If no improvement is obtained, consult a Mitsubishi Electric distributor.
b11	Not used	-
b12	Controlling flag	Turns ON when 4LC is performing control.
b13	Set value being backed up flag	Remains ON while set values are being backed up.
b14	Initialization completed flag	Turns ON when Initialization completed
b15	Temperature control ready flag	Turns ON when 4LC becomes ready for operation.

Operation of temperature control ready flag (b15)

Once the power supply has been turned ON the 4LC is ready. Temperature control ready flag turns ON.

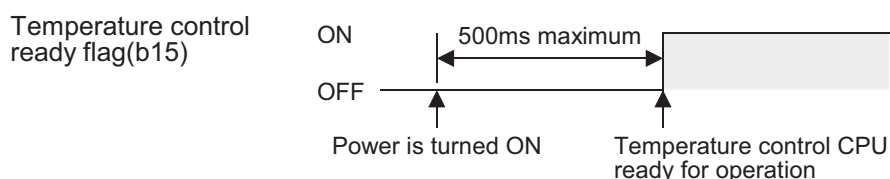

Caution

- While the temperature control ready flag is ON, the 4LC accepts the FROM/TO instructions (or direct buffer memory specification).
- The 4LC does not perform control for approximately 5 seconds after the power is turned ON.

8.2.2 [BFM#1 to 4] Event

The ON/OFF status of each bit indicates the status of each channel.
The bit assignment is the same for all channels.

BFM No.				Description	Initial value	R/W	Backup
CH1	CH2	CH3	CH4				
#1	#2	#3	#4	Event (Refer to the following)	-	R	-

Event

Bit	Item	Description
b0	Input error (upper limit)	Turns ON when input value is over scale.
b1	Input error (lower limit)	Turns ON when input value is under scale.
b2	Cold contact temperature compensation data error	Turns ON when an error has been caused by noise or when a failure has occurred in the 4LC.
b3	A/D converted value error	Turn the power ON again, and check for changes in the state. If no improvement is obtained, consult a Mitsubishi Electric distributor.
b4	Alarm 1	Turns ON when an alarm 1 has occurred.
b5	Alarm 2	Turns ON when an alarm 2 has occurred.
b6	Alarm 3	Turns ON when an alarm 3 has occurred.
b7	Alarm 4	Turns ON when an alarm 4 has occurred.
b8	Loop breaking alarm	Turns ON when a loop breaking alarm has occurred
b9	Heater disconnection alarm	Turns ON when a heater disconnection alarm has occurred.
b10	Current error when output is OFF	Turns ON when a current error occurs while output is OFF.
b11	ST (startup tuning) being performed	Remains ON while startup tuning is being performed.
b12	Decimal point position	Turns ON when input range is set to "0.1°C/°F". 0 : 1°C/°F, mV 1 : 0.1°C/°F
b13	MANUAL mode transition completed flag	Turns ON when transition to manual mode is completed. 0 : AUTO mode 1 : MANUAL mode
b14	AT (auto tuning) being performed	Remains ON while auto tuning is being performed.
b15	Temperature rise completed flag	Turns ON when the temperature rise completion soak time is finished within the temperature rise completion range.

Explanation of operation of the temperature rise completed flag (b15)

This bit notifies that the measured value (PV) reaches near the set value (SV).
When the measured value reaches the temperature rise completion range (BFM#236) and the soak time (BFM#237) is finished, temperature rise completed flag (b15) turns ON.

- For details on the temperature rise completion range, refer to Subsection 8.2.58.
- For details on the temperature rise completion soak time, refer to Subsection 8.2.59.

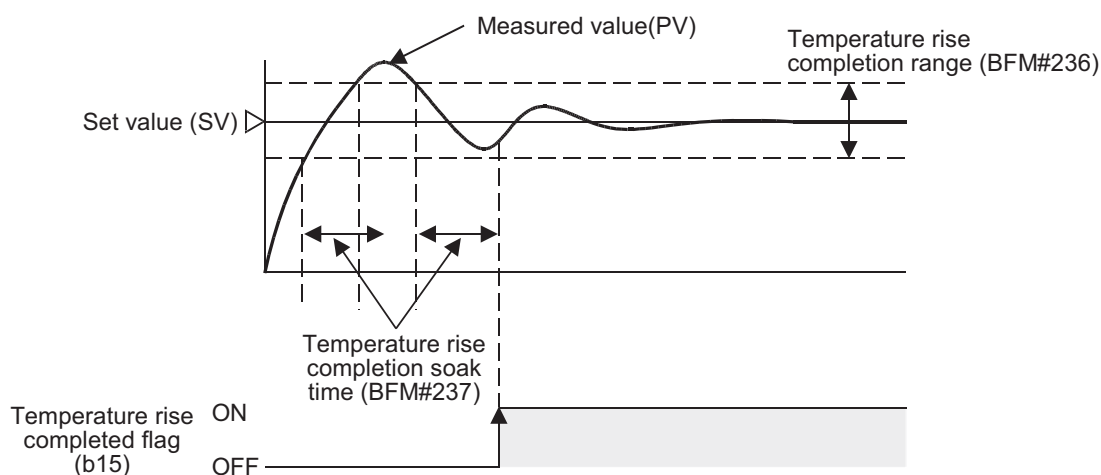

8.2.3 [BFM#5 to 8] Measured value (PV)

These buffer memories store the measured value (PV).

The unit is "°C", "0.1°C", "°F", "0.1°F" or "mV" in accordance with the input type setting.

The displayed measured value (PV) is as follows depending on the input type used.

- When internal input is used
 - 1) These buffer memories store the input value detected by the 4LC subject to the following processing.
 - Sensor correction
 - Primary delay digital filter setting
 - 2) These buffer memories store the following value in accordance with the decimal point position.
 - When the decimal point position is "0", these buffer memories store the measured value as it is.
 - When the decimal point position is "1", these buffer memories store the measured value multiplied by "10".
- When external input is used
 - 1) These buffer memories store the value written in the external input value buffer memory subject to the following processing.
 - Sensor correction
 - Primary delay digital filter setting

→ For details on the input type, refer to Subsection 8.2.52.

→ For details on the decimal point position, refer to Subsection 8.2.2.

→ For details on the sensor correction, refer to Subsection 8.2.32.

→ For details on the primary delay digital filter setting, refer to Subsection 8.2.36.

BFM No.				Description	Initial value	R/W	Backup
CH1	CH2	CH3	CH4				
#5	#6	#7	#8	Display range : <ul style="list-style-type: none"> • When internal temperature input is given: "Input range lower limit - 5% of span" to "Input range upper limit + 5% of span" • When internal micro voltage input is given: "Scaling lower limit - 5% of span" to "Scaling upper limit + 5% of span" • When external temperature input is given. "External input range lower limit - 5% of span" to "External input range upper limit + 5% of span" 	-	R	-

Caution

- When handing a numeric value containing decimal places, these buffer memories store the actual value multiplied by "10".
- "0" is displayed due to measurement data sampling for approximately 5 seconds after the power is turned ON.
The 4LC does not perform control during this period.

1	Introduction
2	Specification
3	System Configuration
4	Installation
5	Wiring
6	Introduction of Functions
7	Alarm
8	Buffer Memory
9	Program Examples
10	Troubleshooting

8.2.4 [BFM#9 to 12] Control output value (MV) monitor/ Heating control output value (MV) monitor

In standard PID control, these buffer memories store the control output value (MV) after PID arithmetic operation or control output value (MV) in MANUAL mode.

In heating/cooling PID control, these buffer memories store the heating control output (MV) after heating/cooling PID arithmetic operation.

BFM No.				Description	Initial value	R/W	Backup
CH1	CH2	CH3	CH4				
#9	#10	#11	#12	Display range : <ul style="list-style-type: none"> • PID control : Output limiter lower limit to Output limiter upper limit • Heating/cooling PID control : -50 to Heating upper output limiter (-5.0% past lower limit) 	-	R	-

Caution

- These buffer memories handle numeric values containing decimal places, and store the actual value multiplied by "10".
- These buffer memories store the -5.0% past the lower limit of the span when control is stopped.

8.2.5 [BFM#13 to 16] Cooling control output value (MV) monitor

In heating/cooling PID control, these buffer memories store the cooling control output value (MV) after heating/cooling PID arithmetic operation.

BFM No.				Description	Initial value	R/W	Backup
CH1	CH2	CH3	CH4				
#13	#14	#15	#16	Display range : -50 to Cooling upper output limiter (-5.0% past lower limit)	-	R	-

Caution

- These buffer memories handle numeric values containing decimal places, and store the actual value multiplied by "10".
- In PID control, these buffer memories store "0". (Not used)
- These buffer memories store the -5.0% past the lower limit of the span when control is stopped.

8.2.6 [BFM#17 to 20] Control output flag

Bit 0 and bit 8 indicate the ON/OFF status of the control output. However, the contents of control output vary depending on the setting of the control mode switch function and transistor output selection function.

When internal transistor outputs are assigned to the control output, bit 0 and bit 8 indicate the transistor output status (ON or OFF). When internal transistor outputs are not assigned to the control output, bit 0 and bit 8 indicate the output status (ON or OFF) in the arithmetic operation result in proportion to time (control output cycle).

BFM No.				Description	Initial value	R/W	Backup
CH1	CH2	CH3	CH4				
#17	#18	#19	#20	Control output flag (Refer to the following)	-	R	-

Control output flag

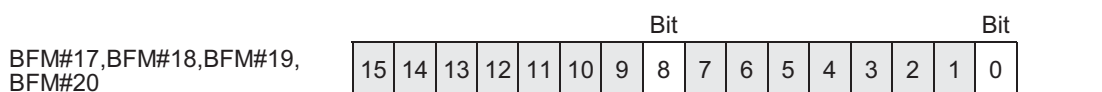

Control type	Control mode switch	Transistor output selection function	Channel	Contents of control output	
				Bit8	Bit0
PID control	0 to 1	-	-	Not used	Transistor output status
	2 to 3	0	-	Not used	Arithmetic operation result in proportion to time
		1 to 2	-	Not used	Transistor output status
		3 to 7	-	Not used	Arithmetic operation result in proportion to time
Heating/cooling PID control	4 to 5	-	1,3	Cooling-side transistor status	Heating-side transistor output status
			2,4	Cooling-side output Arithmetic operation result in proportion to time	Heating-side output Arithmetic operation result in proportion to time
	6 to 7	0	-	Cooling-side transistor output status	Heating-side transistor output status
		1	-	Cooling-side output Arithmetic operation result in proportion to time	Heating-side transistor output status
		2	-	Cooling-side transistor output status	Heating-side output Arithmetic operation result in proportion to time
		3 to 7	-	Cooling-side transistor output status	Heating-side transistor output status

- For details on the control mode switch, refer to Subsection 8.2.62.
- For details on the transistor output selection function, refer to Section 6.3.

Caution

Bits other than bits 0 and 8 are always "0 (OFF)".

- 1 Introduction
- 2 Specification
- 3 System Configuration
- 4 Installation
- 5 Wiring
- 6 Introduction of Functions
- 7 Alarm
- 8 Buffer Memory
- 9 Program Examples
- 10 Troubleshooting

8.2.7 [BFM#21 to 24] Heater current measured value

These buffer memories store the heater current measured value entered from the current detector (CT).

BFM No.				Description	Initial value	R/W	Backup
CH1	CH2	CH3	CH4				
#21	#22	#23	#24	Display range : 0 to 1050 (0.0 to 105.0A)	-	R	-

Caution

- These buffer memories handle numeric values containing decimal places, and store the actual value multiplied by "10".
- When the control mode using external outputs is selected by the control mode switch function, the CT input is not measured. In this case, these buffer memories always store "0".
- When heating/cooling PID control using external outputs is used control, the CT input is not measured. In this case, these buffer memories always store "0".
→ For details on the control mode switch, refer to Subsection 8.2.62.

8.2.8 [BFM#25 to 28] External input value

When the control mode using external outputs is selected by the control mode switch function, set a value corresponding to the measured value (PV) to these buffer memories.

→ For details on the control mode switch, refer to Subsection 8.2.62.

BFM No.				Description	Initial value	R/W	Backup
CH1	CH2	CH3	CH4				
#25	#26	#27	#28	Setting range : -32768 to +32767	0	R/W	-

Caution

- When the setting in the external input value is greater than the external input range upper limit +5%, it is judged as an input upper limit error, and bit 0 of the event buffer memory (BFM#1 to BFM#4) turns ON.
- When the setting in the external input value is smaller than the external input range lower limit - 5%, it is judged as an input lower limit error, and bit 1 of the event buffer memory (BFM#1 to BFM#4) turns ON.

8.2.9 [BFM#29] Control start/stop changeover

This buffer memory starts or stops control.

Write "K0" to stop control and select the monitor mode.

Write "K1" to start the operation selected by the operation mode setting buffer memory.

The setting of this buffer memory is effective for all channels.

→ For details on the operation mode, refer to Subsection 8.2.21.

BFM No.				Description	Initial value	R/W	Backup
CH1	CH2	CH3	CH4				
#29				0 : Stops control 1 : Starts control	0	R/W	-

Caution

- When the PLC main unit is changed over from "RUN" to "STOP", outputs of the 4LC are held. In order to stop outputs of the 4LC, make sure to use BFM#29.
- When the operation mode setting buffer memory is set to "0 (Not used)", the measured value (PV) becomes "0".

8.2.10 [BFM#30] FX Series model code

The model code of the 4LC is stored.

BFM No.				Description	Initial value	R/W	Backup
CH1	CH2	CH3	CH4				
#30				The model code of the 4LC is K2090.	K2090	R	-

8.2.11 [BFM#32 to 35] External output value/Heating external output value monitor

When the control mode using external outputs is selected by the control mode switch function, these buffer memories store the control output processed within the output limit and scaled into the external output range.

→ For details on the control mode switch, refer to Subsection 8.2.62.

BFM No.				Description	Initial value	R/W	Backup
CH1	CH2	CH3	CH4				
#32	#33	#34	#35	Display range : External output range lower limit to external output range upper limit	0	R	-

Caution

When internal output is selected by a control mode change, a control output value (MV) is stored.

→ For details on the control output value (MV), refer to Subsection 8.2.4.

8.2.12 [BFM#36 to 39] Cooling external output value monitor

When the control mode using external outputs is selected by the control mode switch function, these buffer memories store the cooling control output processed within the output limit and scaled into the external output range.

→ For details on the control mode switch, refer to Subsection 8.2.62.

BFM No.				Description	Initial value	R/W	Backup
CH1	CH2	CH3	CH4				
#36	#37	#38	#39	Display range : External output range lower limit to external output range upper limit	0	R	-

Caution

When internal output is selected by a control mode change, a cooling control output value (MV) is stored.

→ For details on the cooling control output value (MV), refer to Subsection 8.2.5.

8.2.13 [BFM#40 to 43] Set value monitor

These buffer memories store the set value used in PID control and alarm function.

These buffer memories indicate transient changes in the set value on the slave side when the setting change ratio limiter is set or during cascade control.

→ For details on the setting change ratio limiter, refer to Subsection 8.2.37.

→ For details on the cascade control, refer to Section 6.7.

BFM No.				Description	Initial value	R/W	Backup
CH1	CH2	CH3	CH4				
#40	#41	#42	#43	Display range : Setting limiter lower limit to Setting limiter upper limit	0	R	-

8.2.14 [BFM#44 to 47] Control mode monitor

These buffer memories indicate the current control mode and cascade control status.
Bit 0 to bit 2 indicate the control mode, and bit 15 indicates the cascade control status.

→ For details on the control mode, refer to Subsection 8.2.62.
→ For details on the cascade control, refer to Section 6.7.

BFM No.				Description	Initial value	R/W	Backup
CH1	CH2	CH3	CH4				
#44	#45	#46	#47	Refer to the following	0	R	-

Control mode (b2 to b0)

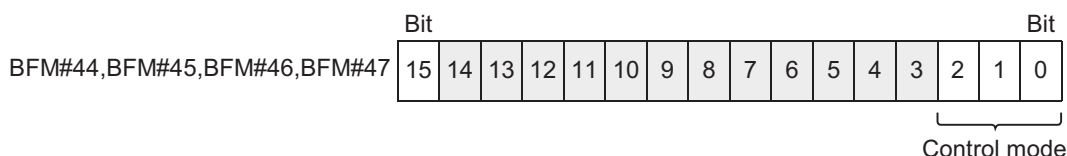

Example :
When bits 0 and 1 are OFF and bit 2 is ON, the value from bit 0 to bit 2 becomes "4".

Bit2 to Bit0 of value	Control mode	Control type	Input	Output
0	0	PID control	Internal	Internal
1	1		External	
2	2		Internal	External
3	3		External	
4	4	Heating/cooling PID control	Internal	Internal
5	5		External	
6	6		Internal	External
7	7		External	

Cascade control status (b15)

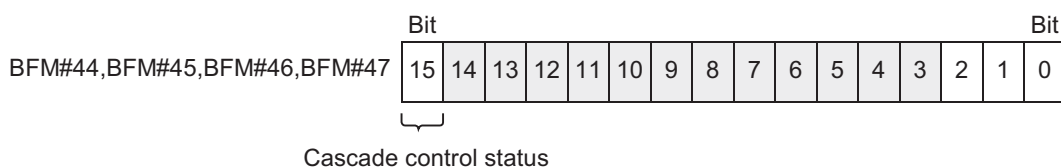

Bit15	Description
0 (OFF)	Cascade control is not being performed.
1 (ON)	Cascade control is being performed.

Caution

Bit 3 to bit 14 are always "0 (OFF)".

8.2.15 [BFM#48][BFM#88][BFM#128][BFM#168] Set value (SV)

To these buffer memories, enter the set value (SV) used in the PID arithmetic operation and alarm function. The unit is "°C", "0.1°C", "°F", "0.1°F" or "mV" in accordance with the input type setting (BFM#208, BFM#214, BFM#220 and BFM#226). Enter a value as follows in accordance with the decimal point position. When the decimal point position is "0", enter a value as it is. When the decimal point position is "1", enter a value multiplied by "10".

- For details on the decimal point position, refer to Subsection 8.2.2.
- For details on the setting limiter upper limit, refer to Subsection 8.2.40.
- For details on the setting limiter lower limit, refer to Subsection 8.2.41.
- For details on the input type, refer to Subsection 8.2.52.

BFM No.				Description	Initial value	R/W	Backup
CH1	CH2	CH3	CH4				
#48	#88	#128	#168	Setting range : Setting limiter lower limit to Setting limiter upper limit	0	R/W	✓

8.2.16 [BFM#49 to 52][BFM#89 to 92][BFM#129 to 132][BFM#169 to 172] Alarm setting value 1 to 4

To these buffer memories, enter the set value of each alarm set by the alarm mode setting buffer memories. The alarm mode setting buffer memories allow arbitrary selection of 4 types of alarms among available 14 types of alarms. Write the setting value 1 to 4 of the alarm after setting the alarm mode. The unit and setting range of the set value vary depending on the selected alarm mode. Enter the set value suitable to the selected alarm mode.

- For details on the alarm mode setting, refer to Subsection 8.2.53.

BFM No.				Description	Initial value	R/W	Backup
CH1	CH2	CH3	CH4				
Alarm 1 setting value							
#49	#89	#129	#169	Setting range : Refer to the following	0	R/W	✓
Alarm 2 setting value							
#50	#90	#130	#170	Setting range : Refer to the following	0	R/W	✓
Alarm 3 setting value							
#51	#91	#131	#171	Setting range : Refer to the following	0	R/W	✓
Alarm 4 setting value							
#52	#92	#132	#172	Setting range : Refer to the following	0	R/W	✓

Setting range

Alarm mode						Setting range
0	Alarm function OFF	-	-	-	-	0
1	Upper limit input value alarm	7	Upper limit input value alarm with wait	-	-	Input range*1
2	Lower limit input value alarm	8	Lower limit input value alarm with wait	-	-	Input range*1
3	Upper limit deviation alarm	9	Upper limit deviation value alarm with wait	12	Upper limit deviation value alarm with re-wait	-span to +span*2
4	Lower limit deviation alarm	10	Lower limit deviation value alarm with wait	13	Lower limit deviation value alarm with re-wait	-span to +span*2
5	Upper/lower limit deviation	11	Upper/lower limit deviation value alarm with wait	14	Upper/lower limit deviation value alarm with re-wait	0 to +span*2
6	Range alarm	-	-	-	-	0 to +span*2

*1. Input range for internal temperature input
Scaling range for internal micro voltage input
External input range for external input

*2. Input span for internal temperature input
Scaling span for internal micro voltage input
External input span for external input

Caution

When handling numbers containing decimal places, multiply the set value by 10.

8.2.17 [BFM#53][BFM#93][BFM#133][BFM#173] Heater disconnection alarm set value

To these buffer memories, enter a value for recognizing heater disconnection or recognizing abnormal current while the output is OFF.

- While the control output is ON
When the heater current measured value is equivalent to or smaller than the heater disconnection alarm set value, a heater disconnection alarm is issued. (b9 of the Event BFM for the relevant channel turns ON.)
- While the control output is OFF
When the heater current measured value is equivalent to or larger than the heater disconnection alarm set value, an abnormal current alarm in the output OFF status is issued. (b10 of the Event BFM for the relevant channel turns ON.)

→ For details on the heater disconnection alarm, refer to Section 6.11.

→ For details on the heater current measured value, refer to Subsection 8.2.7.

BFM No.				Description	Initial value	R/W	Backup
CH1	CH2	CH3	CH4				
#53	#93	#133	#173	Setting range : 0 to 1000 (0.0 to 100.0A)	0	R/W	✓

Caution

- Handling numbers containing decimal places. The set value should be the actual value multiplied by 10.
- As the heater disconnection alarm set value, enter a value smaller than the actual heater current.
- When the control mode using external outputs is selected by the control mode switch function, the heater disconnection alarm function is disabled.
- When "0" is entered, the heater disconnection alarm function is disabled.

8.2.18 [BFM#54][BFM#94][BFM#134][BFM#174] AUTO/MANUAL mode changeover

These buffer memories select AUTO mode or MANUAL mode.

Write "K0" to select AUTO mode.

Write "K1" to select MANUAL mode.

- AUTO mode
The measured value (PV) or external input value is compared with the set value (SV), PID arithmetic operation is performed, and then the control output (MV) is given.
In AUTO mode, the MANUAL output set value becomes equivalent to the control output value (MV).
- MANUAL mode
The control output (MV) is given based on the MANUAL output set value.

→ For details on the AUTO/MANUAL mode changeover, refer to Section 6.10.

BFM No.				Description	Initial value	R/W	Backup
CH1	CH2	CH3	CH4				
#54	#94	#134	#174	0 : AUTO mode 1 : MANUAL mode	0	R/W	✓

Caution

- MANUAL mode is not available while heating/cooling PID control is being performed.
- The alarm function is also enabled in MANUAL mode.

8.2.19 [BFM#55][BFM#95][BFM#135][BFM#175] MANUAL output set value

To these buffer memories, set the output ON ratio in MANUAL mode.

Specify the ratio of the ON duration within the time (sec) specified by the control output cycle setting buffer memories.

ON duration : Control output cycle (sec) × MANUAL output set value (%)

→ For details on the control output cycle setting, refer to Subsection 8.2.34.

BFM No.				Description	Initial value	R/W	Backup
CH1	CH2	CH3	CH4				
#55	#95	#135	#175	Setting range : -50 to +1050 (-5.0% to +105.0%)	-50	R/W ^{*1}	-

*1. These buffer memories can be written only in MANUAL mode.

Example of operation

(When the control output cycle is 30 sec and the MANUAL output set value is 60%)

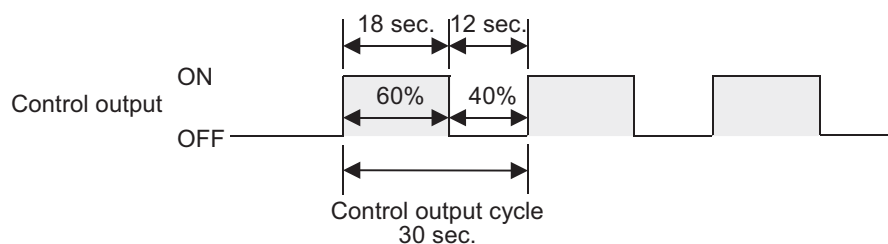

Caution

- Handling numbers containing decimal places. The set value should be the actual value multiplied by 10.
- These buffer memories can be written only in MANUAL mode.
- Write these buffer memories after transfer to MANUAL mode is completed (that is, after b13 of the event buffer memory turns ON).
- The actual output value is within the range from the output limiter lower limit to the output limiter upper limit.
- In AUTO mode, these buffer memories automatically store the control output value (MV).
→ For details on the event, refer to Subsection 8.2.2.

8.2.20 [BFM#56][BFM#96][BFM#136][BFM#176] AT (auto tuning) execution command

These buffer memories stop or perform auto tuning.

Write "K0" to stop auto tuning.

Write "K1" to perform auto tuning.

→ For details on the AT (auto tuning), refer to Section 6.8.

BFM No.				Description	Initial value	R/W	Backup
CH1	CH2	CH3	CH4				
#56	#96	#136	#176	0 : Stops AT (auto tuning) 1 : Performs AT (auto tuning)	0	R/W	✓

Caution

- When performing auto tuning again, write "K0", wait for 0.5 sec or more, and then write "K1" again.
- Auto tuning can be performed in PID control and heating/cooling PID control.
- Auto tuning is not started if conditions for performing auto tuning are not satisfied.
→ For details on the conditions for performing AT (auto tuning), refer to Subsection 6.8.2.

8.2.21 [BFM#57][BFM#97][BFM#137][BFM#177] Operation mode

These buffer memories specify the operation mode among "Monitor + Alarm + Control", "Monitor + Alarm", "Monitor" and "Not used".

Write "K0" not to use the channel.

Write "K1" to only monitor the measured value.

Write "K2" to monitor the measured value and issue alarms.

Write "K3" to monitor the measured value, issue alarms and perform control (all operations).

The operation status varies depending on the combination with the setting of the control start/stop changeover buffer memory. For the details, refer to "Operation status resulting from the combination with the setting of the control start/stop changeover buffer memory" below.

→ For details on the control start/stop changeover, refer to Subsection 8.2.9.

BFM No.				Description	Initial value	R/W	Backup
CH1	CH2	CH3	CH4				
#57	#97	#137	#177	0 : Not used 1 : Monitor 2 : Monitor + Alarm 3 : Monitor + Alarm + Control	3	R/W	✓

Operation status resulting from the combination with the setting of the control start/stop changeover buffer memory

Starts control/ Stops control	Description	Operation mode			
		0 : Not used	1 : Monitor	2 : Monitor + Alarm	3 : Monitor + Alarm + Control
0 : Stops control	Measured value (PV)	0	Measured value is displayed.		
	Alarm operation	Alarm function is disabled.			
	Output (Transistor output selection 0 to 2) ^{*1}	Output OFF			
	Output (Transistor output selection 3 to 6) ^{*1}	Output OFF			
	Output (Transistor output selection 7) ^{*1}	Output OFF			
1 : Starts control	Measured value (PV)	0	Measured value is displayed.		
	Alarm operation	Alarm function is disabled.		Alarm function is enabled.	
	Output (Transistor output selection 0 to 2) ^{*1}	Output OFF			Arithmetic operation result in proportion to time
	Output (Transistor output selection 3 to 6) ^{*1}	Output OFF		Alarm status	
	Output (Transistor output selection 7) ^{*1}	Output OFF			Loop breaking alarm status

*1. For details on the transistor output selection function, refer to Section 6.3.

8.2.22 [BFM#58][BFM#98][BFM#138][BFM#178] Proportional band (P)/ Heating proportional band (P)

To these buffer memories, set the proportional band (P) for performing standard PID control, or the proportional band (P) on the heating side for performing heating/cooling PID control.

The proportional band is required to give the control output in proportion to the deviation (difference between the set value (SV) and the measured value (PV)).

As the value set here increases, changes in the control output (MV) versus changes in the input become smaller. Conversely, as the value set here decreases, changes in the control output (MV) become larger. Note that too large a proportional band value increases the overshoot, and requires a longer time until the output value (MV) reaches the set value (SV) and becomes stable.

BFM No.				Description	Initial value	R/W	Backup
CH1	CH2	CH3	CH4				
#58	#98	#138	#178	Setting range : 0 to 10000 (0.0 to 1000.0% of span) ^{*1}	30	R/W	✓

- *1. Input span for internal temperature input
Scaling span for internal micro voltage input
External input span for external input

Caution

- Handling numbers containing decimal places. The set value should be the actual value multiplied by 10.
- In standard PID control, the set value "0" specifies two-position operation.
- In heating/cooling PID control, the set value "0" specifies two-position operation on both the heating side and the cooling side.

8.2.23 [BFM#59][BFM#99][BFM#139][BFM#179] Cooling proportional band (P)

To these buffer memories, set the proportional band (P) on the cooling side for performing heating/cooling PID control.

BFM No.				Description	Initial value	R/W	Backup
CH1	CH2	CH3	CH4				
#59	#99	#139	#179	Setting range : 1 to 10000 (0.1 to 1000.0% of span) ^{*1}	30	R/W	✓

- *1. Input span for internal temperature input
Scaling span for internal micro voltage input
External input span for external input

Caution

- Handling numbers containing decimal places. The set value should be the actual value multiplied by 10.
- In standard PID control, these buffer memories store "0". (Not used)
- When "0" is set to the proportional band on the heating side, the setting of the proportional band on the cooling side is invalid. It is not possible to perform two-position operation only on the cooling side.

1

Introduction

2

Specification

3

System Configuration

4

Installation

5

Wiring

6

Introduction of Functions

7

Alarm

8

Buffer Memory

9

Program Examples

10

Troubleshooting

8.2.24 [BFM#60][BFM#100][BFM#140][BFM#180] Integral time (I)

To these buffer memories, set the integral time (I) for performing PID control.

The integral operation changes the control output in proportion to the area made by the deviation size and deviation generation time.

In proportional operation, deviation (difference between the set value (SV) and the measured value (PV)) may be generated due to natural radiation even if the control output is stable.

Integral operation eliminates this deviation. The integral time refers to the time in which the control output given by the proportional operation is obtained only by the integral operation.

As the integral time is decreased, the integral efficiency is better.

BFM No.				Description	Initial value	R/W	Backup
CH1	CH2	CH3	CH4				
#60	#100	#140	#180	Setting range : 0 to 3600 (sec.)	240	R/W	✓

Caution

When "0" is entered, the integral time (I) setting is invalid.

8.2.25 [BFM#61][BFM#101][BFM#141][BFM#181] Derivative time (D)

To these buffer memories, set the derivative time (D) for performing PID control.

Derivative operation changes the control output in proportion to the change in speed of the measured value (PV) to prevent an increase in the deviation (difference between the set value (SV) and the measured value (PV)).

Because derivative operation responds to the rate at which the measured value (PV) changes, the response to disturbances (noise in measured value caused by external factors) is improved. The derivative time refers to the time in which the control output given by proportional operation is obtained only by derivative operation while the deviation increases and decreases at a constant ratio.

As the derivative time increases, the derivative effect increases.

BFM No.				Description	Initial value	R/W	Backup
CH1	CH2	CH3	CH4				
#61	#101	#141	#181	Setting range : 0 to 3600 (sec.)	60	R/W	✓

Caution

When "0" is entered, the derivative time (D) setting is invalid.

8.2.26 [BFM#62][BFM#102][BFM#142][BFM#182] Control response parameter

To these buffer memories, set the control response parameter.
Select the response to changes in the set value (SV) in PID control among three steps (slow, medium and fast).

Write "K0" to specify "Slow".
Write "K1" to specify "Medium".
Write "K2" to specify "Fast".

BFM No.				Description	Initial value	R/W	Backup
CH1	CH2	CH3	CH4				
#62	#102	#142	#182	0 : Slow 1 : Medium 2 : Fast	0	R/W	✓

Explanation of operation

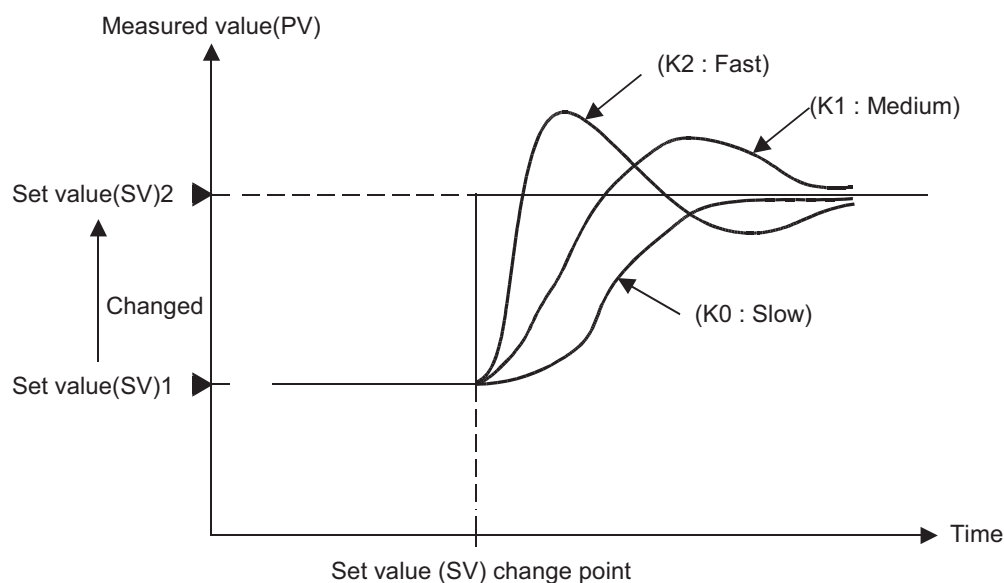

Set value	Description
0 : Slow	Set this value to restrain the overshoot.
1 : Medium	The overshoot is smaller than "2: Fast".
2 : Fast	Set this value to reduce the rising time (that is, to start operation early). Note that some overshoot cannot be avoided.

- 1 Introduction
- 2 Specification
- 3 System Configuration
- 4 Installation
- 5 Wiring
- 6 Introduction of Functions
- 7 Alarm
- 8 Buffer Memory
- 9 Program Examples
- 10 Troubleshooting

8.2.27 [BFM#63][BFM#103][BFM#143][BFM#183] Overlap/Dead band

To these buffer memories, set the range of the overlap area or dead band for heating/cooling PID control.
 Enter a value in the range from -100 to -1 (negative value) to set the overlap area.
 Enter a value in the range from +1 to +100 (positive value) to set the dead band.
 Set "0" not to use the overlap area or dead band.

→ For details on the overlap/dead band, refer to Subsection 6.6.3.

BFM No.				Description	Initial value	R/W	Backup
CH1	CH2	CH3	CH4				
#63	#103	#143	#183	Setting range : • PID control : 0 (Not used) • Heating/cooling PID control : -100 to +100 (-10.0 to +10.0% of span) ^{*1}	0	R/W ^{*2}	✓

- *1. Input span for internal temperature input
 Scaling span for internal micro voltage input
 External input span for external input
- *2. These buffer memories can be written only while heating/cooling PID control is being performed.

Explanation of operation

Overlap:

The proportional band on the heating side and proportional band on the cooling side overlap in the overlap area.

When the measured value (PV) is located within the overlap area, both the control output on the heating side and the control output on the cooling side are given at the same time.

Dead band:

The dead band (dead zone) is located between the proportional band on the heating side and the proportional band on the cooling side.

When the measured value (PV) is located within the dead band, both the control output on the heating side and the control output on the cooling side are not output.

Control output value (MV)

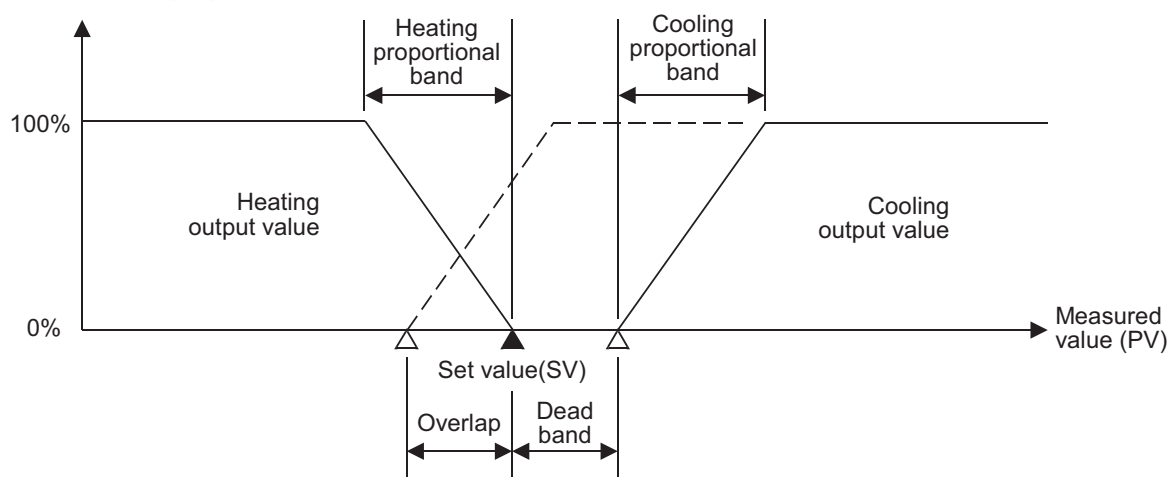

Caution

- The setting of the overlap area/dead band is invalid while two-position control is being performed.
- These buffer memories store "0" while standard PID control is being performed. (Not used)
- Set the overlap area within the proportional band setting range.

8.2.28 [BFM#64][BFM#104][BFM#144][BFM#184] Output limiter upper limit/ Heating upper output limiter

To these buffer memories, set the output limiter upper limit/heating output limiter upper limit for setting the upper limit of the control output value (MV).

Set the upper limit of the output for standard PID control.

Set the upper limit of the output on the heating side for heating/cooling PID control.

→ For details on the output limiter lower limit, refer to Subsection 8.2.29.

→ For details on the cooling upper output limiter setting, refer to Subsection 8.2.30.

BFM No.				Description	Initial value	R/W	Backup
CH1	CH2	CH3	CH4				
#64	#104	#144	#184	Setting range : • PID control : Output limiter lower limit + 1 to 1050 (to 105.0%) • Heating/cooling PID control : 0 to 1050 (0.0 to 105.0%)	1000	R/W	✓

Example of operation

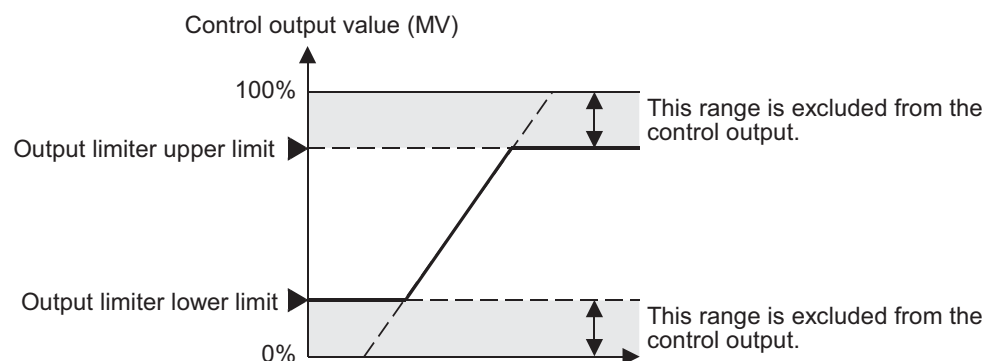

Caution

- Handling numbers containing decimal places. The set value should be the actual value multiplied by 10.
- The setting of the output limiter upper limit/heating output limiter upper limit is invalid while two-position control is being performed.
- The setting of the output limiter lower limit is invalid while heating/cooling PID control is being performed.
- Proper PID constants may not be obtained if the output limiter upper limit/heating output limiter upper limit is set and auto tuning is performed.
Do not set the output limiter upper limit/heating output limiter upper limit when performing auto tuning.

1

Introduction

2

Specification

3

System Configuration

4

Installation

5

Wiring

6

Introduction of Functions

7

Alarm

8

Buffer Memory

9

Program Examples

10

Troubleshooting

8.2.29 [BFM#65][BFM#105][BFM#145][BFM#185] Output limiter lower limit

To these buffer memories, set the output limiter lower limit for setting the lower limit of the control output value (MV).

→ For an operation example of the output limiter lower limit, refer to Subsection 8.2.28.

→ For details on the output limiter upper limit/heating upper output limiter, refer to Subsection 8.2.28.

BFM No.				Description	Initial value	R/W	Backup
CH1	CH2	CH3	CH4				
#65	#105	#145	#185	Setting range : • PID control : -50 to Output limiter upper limit-1 (-5.0% to) • Heating/cooling PID control : 0 (Not used)	0	R/W ^{*1}	✓

*1. These buffer memories can be written only while standard PID control is being performed.

Caution

- Handling numbers containing decimal places. The set value should be the actual value multiplied by 10.
- The setting of the output limiter lower limit is invalid while two-position control is being performed.
- The setting of the output limiter lower limit is invalid while heating/cooling PID control is being performed.
- Proper PID constants may not be obtained if the output limiter lower limit is set and auto tuning is performed.
Do not set the output limiter lower limit when performing auto tuning.

8.2.30 [BFM#66][BFM#106][BFM#146][BFM#186] Cooling upper output limiter setting

To these buffer memories, set the output limiter upper limit on the cooling side for setting the upper limit of the control output value (MV) on the cooling side.

→ For details on the output limiter upper limit/heating upper output limiter, refer to Subsection 8.2.28.

BFM No.				Description	Initial value	R/W	Backup
CH1	CH2	CH3	CH4				
#66	#106	#146	#186	Setting range : • PID control : 0 (Not used) • Heating/cooling PID control : 0 to 1050 (0.0 to 105.0%)	0 ^{*1}	R/W ^{*2}	✓

*1. 1000 in the case of heating/cooling PID control.

*2. These buffer memories can be written only while heating/cooling PID control is being performed.

Caution

- Handling numbers containing decimal places. The set value should be the actual value multiplied by 10.
- The setting of the cooling output limiter upper limit is invalid while two-position control is being performed.
- The setting of the cooling output limiter upper limit is invalid while standard PID control is being performed.
- Proper PID constants may not be obtained if the cooling output limiter upper limit is set and auto tuning is performed.
Do not set the cooling output limiter upper limit when performing auto tuning.

8.2.31 [BFM#67][BFM#107][BFM#147][BFM#187] Output change ratio limiter

The output change ratio limiter function limits changes in the control output value (MV) per unit time (1 sec). The preset output change ratio limits the control output. The output does not change drastically but is given in accordance with the preset inclination when the power is turned ON (and the output is outside the proportional band) or when the set value is changed (significantly).

BFM No.				Description	Initial value	R/W	Backup
CH1	CH2	CH3	CH4				
#67	#107	#147	#187	Setting range : • PID control : 0 to 1000 (0.0 to 100.0%/sec.) • Heating/cooling PID control : 0 (Not used)	0	R/W*1	✓

*1. These buffer memories can be written only while standard PID control is being performed.

Example of operation

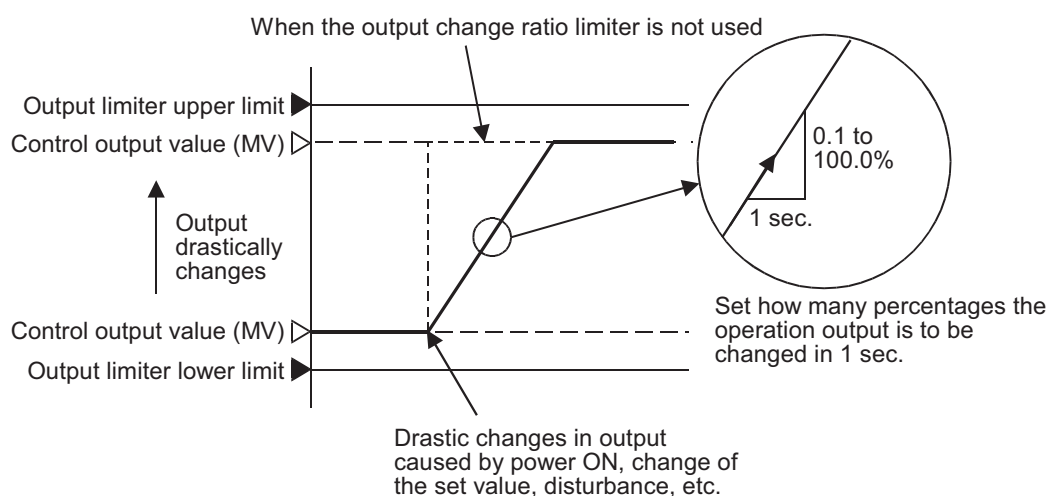

Caution

- Handling numbers containing decimal places. The set value should be the actual value multiplied by 10.
- Entering a small value to these buffer memories (to make the inclination smaller) makes the control response slow, and eliminates the derivative effect.
- The output change ratio limiter is disabled while two-position control is being performed.
- The output change ratio limiter is disabled while heating/cooling PID control is being performed.
- The output change ratio limiter is disabled when "0" is entered to these buffer memories.
- Proper PID constants may not be obtained if the output change ratio limiter is set and auto tuning is performed.
Do not set the output change ratio limiter when performing auto tuning.

1 Introduction

2 Specification

3 System Configuration

4 Installation

5 Wiring

6 Introduction of Functions

7 Alarm

8 Buffer Memory

9 Program Examples

10 Troubleshooting

8.2.32 [BFM#68][BFM#108][BFM#148][BFM#188] Sensor correction value setting

To these buffer memories, enter the sensor correction value for correcting the dispersion among sensors or correcting differences in the measured value (PV) from other instruments.
The actual input value is added to the sensor correction value, and then stored in the measured value (PV) buffer memory.

→ For details on the measured value (PV), refer to Subsection 8.2.3.

BFM No.				Description	Initial value	R/W	Backup
CH1	CH2	CH3	CH4				
#68	#108	#148	#188	Setting range : -5000 to +5000 (-50.00 to +50.00% of span) ^{*1}	0	R/W	✓

- *1. Input span for internal temperature input
- Scaling span for internal micro voltage input
- External input span for external input

Example of operation

Condition

When the input range span is 400°C and correction by 2°C is required

Sensor correction value

$$2\text{ (}^\circ\text{C)} / 400\text{ (}^\circ\text{C)} \times 100 = 0.5\text{ (\%)}$$

Display value

$$\text{Displayed value} = \text{Measured value (PV)} + \text{Sensor correction value}$$

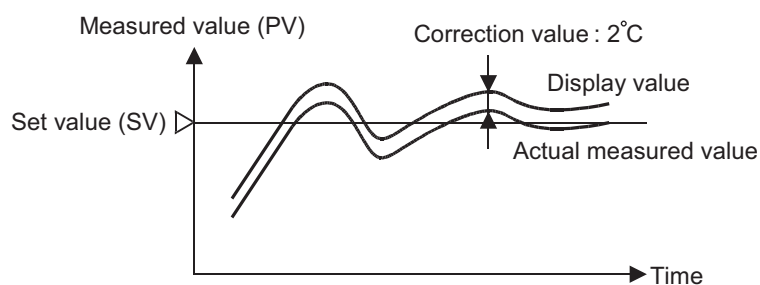

Caution

Handling numbers containing decimal places. The set value should be the actual value multiplied by 100.

8.2.33 [BFM#69][BFM#109][BFM#149][BFM#189] Adjustment sensitivity (dead zone) setting

To these buffer memories, enter the adjustment sensitivity (dead zone) to prevent chattering of the control output (MV) around the set value (SV) during two-position control.
The value entered to these buffer memories is divided into two and distributed upward and downward around the set value (SV).

→ For details on the set value (SV), refer to Subsection 8.2.15.

BFM No.				Description	Initial value	R/W	Backup
CH1	CH2	CH3	CH4				
#69	#109	#149	#189	Setting range : 1 to 100 (0.1 to 10.0% of span) ^{*1}	10	R/W	✓

- *1. Input span for internal temperature input
- Scaling span for internal micro voltage input
- External input span for external input

Example of operation

When the input range span is 400°C and the adjustment sensitivity (dead zone) is set to "10%"
 $400\text{ (}^\circ\text{C)} \times 10.0\text{ (}\%\text{)} / 100 = 40\text{ (}^\circ\text{C)}$

When the set value is 200°C, the range from 180 to 220°C is handled as the dead zone.

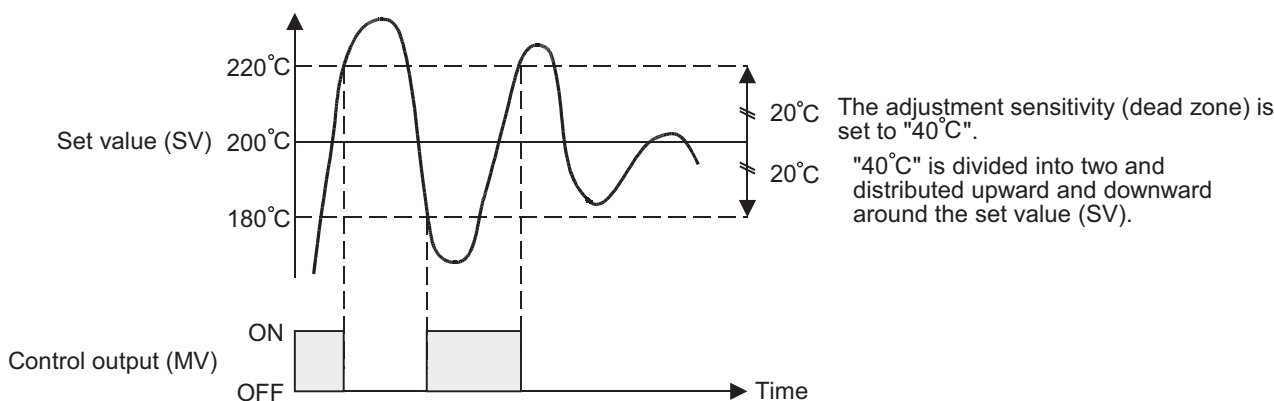

Caution

- Handling numbers containing decimal places. The set value should be the actual value multiplied by 10.
- Entering a large value (to create wide adjustment sensitivity area (dead zone)) increases vertical fluctuation. Entering too small a value generates chattering due to small oscillations of the measured value.

1 Introduction
2 Specification
3 System Configuration
4 Installation
5 Wiring
6 Introduction of Functions
7 Alarm
8 Buffer Memory
9 Program Examples
10 Troubleshooting

8.2.34 [BFM#70][BFM#110][BFM#150][BFM#190] Control output cycle setting/ Heating control output period setting

To these buffer memories, enter the control output (MV) cycle. For heating/cooling PID control, enter the control output (MV) cycle on the heating side.

Set the time in which the control output (MV) turns ON and OFF.

The ON duration and OFF duration of the control output (MV) are as follows.

ON duration :

Control output cycle/Control output cycle on heating side (sec) × Control output value (%)

OFF duration :

Control output cycle/Control output cycle on heating side (sec) × (100 - Control output value (%))

BFM No.				Description	Initial value	R/W	Backup
CH1	CH2	CH3	CH4				
#70	#110	#150	#190	Setting range : 5 to 1000 (0.5 to 100.0 sec.)	300	R/W	✓

Example of operation

(When the control output cycle is 30 sec and the control output value (MV) is 60%)

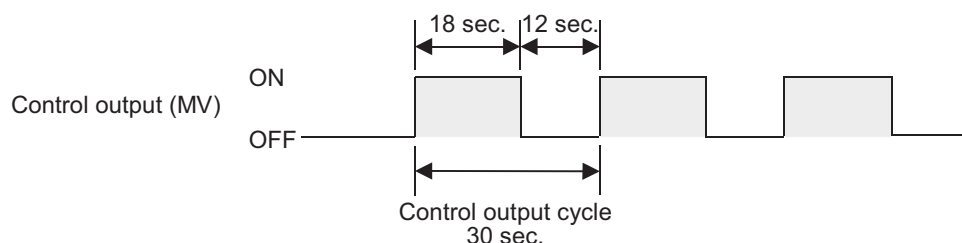

Caution

Handling numbers containing decimal places. The set value should be the actual value multiplied by 10.

8.2.35 [BFM#71][BFM#111][BFM#151][BFM#191] Cooling control output period setting

To these buffer memories, enter the control output (MV) cycle on the cooling side for heating/cooling PID control.

The ON duration and OFF duration of the control output (MV) are as follows.

ON duration :

Control output cycle on cooling side (sec) × Control output value (%)

OFF duration :

Control output cycle on cooling side (sec) × (100 - Control output value (%))

→ For an operation example of the control output cycle on the cooling side, refer to Subsection 8.2.34.

BFM No.				Description	Initial value	R/W	Backup
CH1	CH2	CH3	CH4				
#71	#111	#151	#191	Setting range : • PID control : 0 (Not used) • Heating/cooling PID control : 5 to 1000 (0.5 to 100.0 sec.)	300	R/W ^{*1}	✓

*1. These buffer memories can be written only while heating/cooling PID control is being performed.

Caution

Handling numbers containing decimal places. The set value should be the actual value multiplied by 10.

8.2.36 [BFM#72][BFM#112][BFM#152][BFM#192] Primary delay digital filter setting

To these buffer memories, enter the primary delay digital filter for reducing fluctuations caused by noise in the measured value (MV).

The effect of noise is mitigated by setting the time constant of the digital filter here in accordance with the control target characteristics and noise level.

Entering too small a value may not give the filter a beneficial effect. Entering too large a value deteriorates the input response.

BFM No.				Description	Initial value	R/W	Backup
CH1	CH2	CH3	CH4				
#72	#112	#152	#192	Setting range : 0 to 100 (sec.)	0	R/W	✓

Example of operation

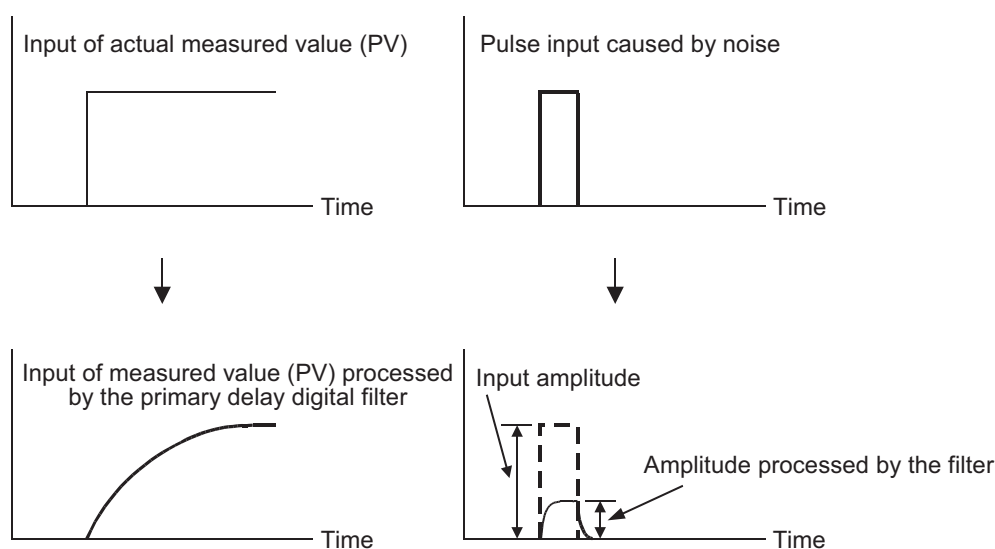

Caution

- The primary delay digital filter is invalid when "0" is entered, and the measured value is acquired in the sampling period (250ms).
- When the measured value (PV) before processing by the digital filter is outside the acquisition range (input value error) continuously in 2 sampling periods, the digital filter is not applied.

1

Introduction

2

Specification

3

System Configuration

4

Installation

5

Wiring

6

Introduction of Functions

7

Alarm

8

Buffer Memory

9

Program Examples

10

Troubleshooting

8.2.37 [BFM#73][BFM#113][BFM#153][BFM#193] Setting change ratio limiter

When the set value (SV) is changed, the setting change ratio limiter function changes the difference between the former set value (SV) and the new set value (SV) gradually. Use this function to avoid drastic change in the set value (SV).

To these buffer memories, enter the change ratio (%) of the set value per minute.

The set value monitor buffer memory indicates the set value (SV) is being changed.

→ **For details on the set value monitor, refer to Subsection 8.2.13.**

BFM No.				Description	Initial value	R/W	Backup
CH1	CH2	CH3	CH4				
#73	#113	#153	#193	Setting range : 0 to 1000 (0.0 to 100.0% of span) ^{*1}	0	R/W	✓

- *1. Input span for internal temperature input
Scaling span for internal micro voltage input
External input span for external input

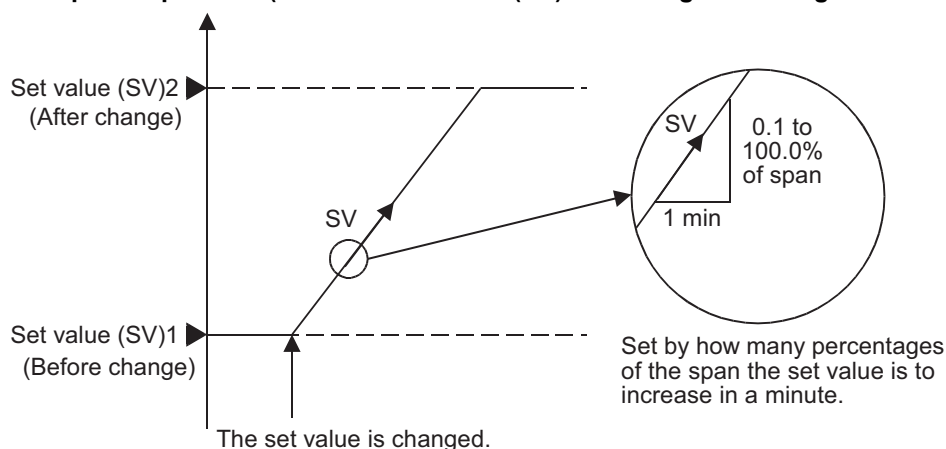
Example of operation (When the set value (SV) 1 is changed to a larger set value (SV) 2)**Operation when the control status is changed from stop to start**

- The measured value (PV) at the time of changeover changes toward the set value (SV) in accordance with the setting change ratio limiter.
- If the measured value (PV) at the time of changeover is outside the setting limiter range, the setting limiter value changes toward the set value (SV) in accordance with the setting change ratio limiter.
- If the measured value (PV) at the time of changeover is outside the acquisition range (input value error), the setting change ratio limiter is not applied.
 - **For details on the setting limiter upper limit, refer to Subsection 8.2.40.**
 - **For details on the setting limiter lower limit, refer to Subsection 8.2.41.**

Operation when auto tuning is performed

If auto tuning is performed while the setting change ratio limiter is applied, auto tuning is started after the operation involving the setting change ratio limiter is finished. If the AT bias is set, auto tuning is started after the AT point is reached.

Caution

- Handling numbers containing decimal places. The set value should be the actual value multiplied by 10.
- If any value other than "0" is entered, the alarm waiting operation is invalid when the set value (SV) is changed.
- If "0" is entered, the setting change ratio limiter is invalid and the set value immediately changes.
- If the value of the setting change ratio limiter is changed while the setting change ratio limiter is applied, the rate of change is calculated again, and operation is continued using the new calculated rate of change.

8.2.38 [BFM#74][BFM#114][BFM#154][BFM#194] AT (auto tuning) bias

To these buffer memories, enter the AT bias to prevent the measured value (PV) from exceeding the set value (SV) during auto tuning.

The auto tuning function performs two-position control using the set value (SV), hunts the measured value (PV), then calculates and sets each PID constant. However, for some control targets, overshoot caused by hunting is not desirable. When the AT bias is set, the set value (SV) = AT point with which auto tuning is performed can be changed.

→ For details on the AT (auto tuning), refer to Section 6.8.

BFM No.				Description	Initial value	R/W	Backup
CH1	CH2	CH3	CH4				
#74	#114	#154	#194	Setting range : -span to +span*1	0	R/W	✓

- *1. Input span for internal temperature input
- Scaling span for internal micro voltage input
- External input span for external input

Example of operation (When the AT bias is set to "-")

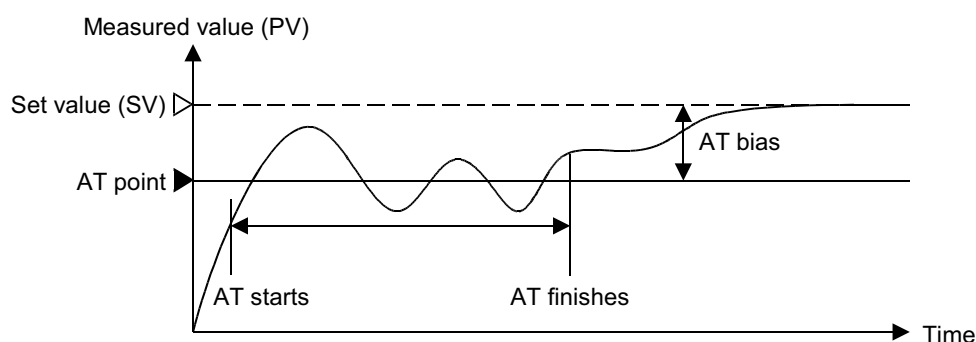

Caution

- When handling numbers containing decimal places, multiply the set value by 10.
- If "Set value (SV) + AT bias" is outside the setting limiter range, auto tuning is performed using the setting limiter value.
- If any value other than "0" is set to the setting change ratio limiter when auto tuning is started, the set value (SV) changes in accordance with the setting change ratio limiter until the AT point. When the set value (SV) reaches the AT point, b14 "AT being performed" of the event buffer memory turns ON and auto tuning is started.

→ For details on the event, refer to Subsection 8.2.2.

→ For details on the setting change ratio limiter, refer to Subsection 8.2.37.

→ For details on the setting limiter upper limit, refer to Subsection 8.2.40.

→ For details on the setting limiter lower limit, refer to Subsection 8.2.41.

1 Introduction
2 Specification
3 System Configuration
4 Installation
5 Wiring
6 Introduction of Functions
7 Alarm
8 Buffer Memory
9 Program Examples
10 Troubleshooting

8.2.39 [BFM#75][BFM#115][BFM#155][BFM#195] Normal/reverse operation selection

To these buffer memories, set whether normal operation or reverse operation is performed in standard PID control.

Enter "K0" to specify normal operation.

Enter "K1" to specify reverse operation.

BFM No.				Description	Initial value	R/W	Backup
CH1	CH2	CH3	CH4				
#75	#115	#155	#195	Setting range : • PID control : 0 : Normal operation 1 : Reverse operation • Heating/cooling PID control : 0 (Not used)	1	R/W ^{*1}	✓

*1. These buffer memories can be written only while standard PID control is being performed.

Operation

- Normal operation
The control output (MV) increases as the measured value (PV) increases.
Normal operation is generally used for cooling control.

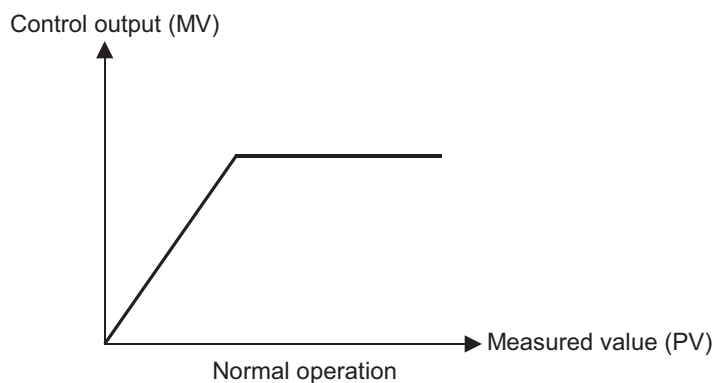

- Reverse operation
The control output (MV) decreases as the measured value (PV) increases.
Reverse operation is generally used for heating control.

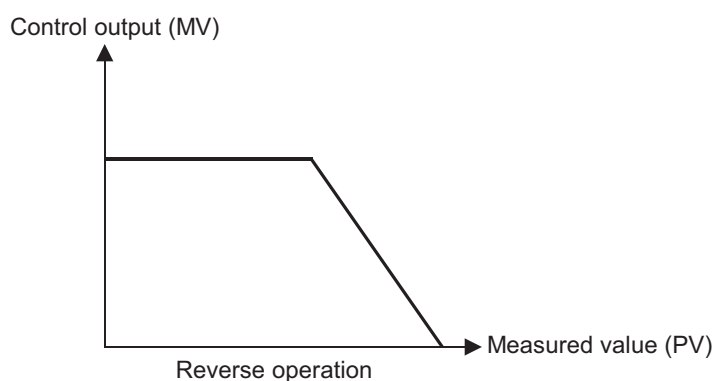

Caution

The setting of normal operation/reverse operation is invalid while heating/cooling PID control is being performed.

8.2.40 [BFM#76][BFM#116][BFM#156][BFM#196] Setting limiter upper limit

To these buffer memories, set the setting limiter upper limit for setting the upper limit of the set value (SV).

→ For details on the set value (SV), refer to Subsection 8.2.15.

→ For details on the setting limiter lower limit, refer to Subsection 8.2.41.

BFM No.				Description	Initial value	R/W	Backup
CH1	CH2	CH3	CH4				
#76	#116	#156	#196	Setting range : • Internal temperature input : "Setting limiter lower limit + 1" to "Input range upper limit" • Internal micro voltage : "Setting limiter lower limit + 1" to "Scaling range upper limit" • External input : "Setting limiter lower limit + 1" to "External input range upper limit"	1300	R/W	✓

Example of operation

(When the input range is "-100 to +1300°C", the setting limiter upper limit is "1000°C" and the setting limiter lower limit is "0°C")

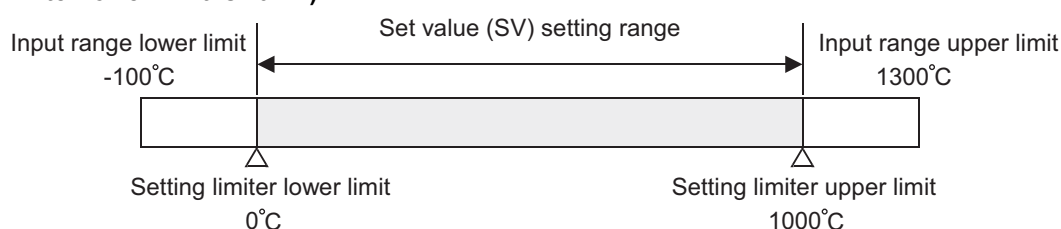

Caution

- When handling numbers containing decimal places, multiply the set value by 10.
- If a value outside the setting limiter range is entered, the set value range error flag (b1) turns ON. If the setting limiter upper limit or setting limiter lower limit becomes outside the input range due to a change of the input type, the set value range error flag (b1) turns ON.
When changing the input type, make sure that the setting limiter upper limit and lower limit do not exceed the input range.

→ For details on the input type, refer to Subsection 8.2.52.

→ For details on the flag, refer to Subsection 8.2.1.

8.2.41 [BFM#77][BFM#117][BFM#157][BFM#197] Setting limiter lower limit

To these buffer memories, set the setting limiter lower limit for setting the lower limit of the set value (SV).

→ For details on the set value (SV), refer to Subsection 8.2.15.

→ For an operation example of the setting limiter lower limit, refer to Subsection 8.2.40.

→ For details on the setting limiter upper limit, refer to Subsection 8.2.40.

BFM No.				Description	Initial value	R/W	Backup
CH1	CH2	CH3	CH4				
#77	#117	#157	#197	Setting range : • Internal temperature input : "Input range lower limit" to "Setting limiter upper limit -1" • Internal micro voltage : "Scaling range lower limit" to "Setting limiter upper limit -1" • External input : "External input range lower limit" to "Setting limiter upper limit -1"	-100	R/W	✓

Caution

- When handling numbers containing decimal places, multiply the set value by 10.
- If a value outside the setting limiter range is entered, the set value range error flag (b1) turns ON. If the setting limiter upper limit or setting limiter lower limit becomes outside the input range due to a change of the input type, the set value range error flag (b1) turns ON.
When changing the input type, make sure that the setting limiter upper limit and lower limit do not exceed the input range.

→ For details on the input type, refer to Subsection 8.2.52.

→ For details on the flag, refer to Subsection 8.2.1.

8.2.42 [BFM#78][BFM#118][BFM#158][BFM#198] Loop breaking alarm judgement time

To these buffer memories, enter the loop breaking alarm judgment time.

The loop breaking alarm function starts to detect the variation of the measured value (PV), at every loop breaking alarm judgment time when the output becomes more than 100% (or the output limiter upper limit) or less than 0% (or the output limiter lower limit), then sets to ON the loop breaking alarm when judging that there is an abnormality in the control loop.

→ For details on the loop breaking alarm function, refer to Section 6.12.

BFM No.				Description	Initial value	R/W	Backup
CH1	CH2	CH3	CH4				
#78	#118	#158	#198	Setting range : • PID control : 0 to 7200 (sec.) • Heating/cooling PID control : 0 (Not used)	480	R/W ^{*1}	✓

*1. These buffer memories can be written only while standard PID control is being performed.

Operation

The loop breaking alarm is issued in the following cases.

- PID control (reverse operation)

When output is less than 0% or output limiter lower limit	When measured value (PV) does not decrease at least by loop breaking change criteria ^{*2} within loop breaking alarm judgement time, an alarm is issued.
When output is more than 100% or output limiter upper limit	When measured value (PV) does not increase at least by loop breaking change criteria ^{*2} within loop breaking alarm judgement time, an alarm is issued.

- PID control (normal operation)

When output is less than 0% or output limiter lower limit	When measured value (PV) does not decrease at least by loop breaking change criteria ^{*2} within loop breaking alarm judgement time, an alarm is issued.
When output is more than 100% or output limiter upper limit	When measured value (PV) does not increase at least by loop breaking change criteria ^{*2} within loop breaking alarm judgement time, an alarm is issued.

*2. The variation range for loop breaking alarm judgment is fixed as follows, and cannot be changed.
 2.0°C for internal temperature input
 0.2% of the scaling span for internal micro voltage input
 0.2% of the external input span for external input

Caution

- The loop breaking alarm function judges abnormalities in the control loop, but cannot detect positions in which abnormalities occur. Check each part of the control system in turn.
- When the AT (auto tuning) function is completed, the loop breaking alarm judgement time is automatically set to the integral time result multiplied by 2.
- Set the time in which the measured increments changes by 2.0°C or 0.2% of the span or longer as the loop breaking alarm judgement time.
 If the loop breaking alarm judgement time is too short or is not suitable to control targets, the loop breaking alarm may repeatedly turn on and off or may not turn ON. In such a case, change the loop breaking alarm judgement time in accordance with the situation.
- In heating/cooling PID control, the loop breaking alarm function is disabled.
- While AT (auto tuning) is performed, the loop breaking alarm function is disabled.
- When "0" is entered, the loop breaking alarm function is disabled.

8.2.43 [BFM#79][BFM#119][BFM#159][BFM#199] Loop breaking alarm dead zone

Set the loop breaking alarm judgement time.

The loop breaking alarm function may issue alarms caused by disturbances (effect of another heat source, etc.) even if there is no abnormality in the control system. In order to prevent such alarms, by setting the loop breaking alarm dead zone, the region in which the alarm function is disabled (non-alarm status region) can be set.

For example, if the loop breaking alarm dead zone is set to "10 °C", 10 °C above the set value (SV) and 10°C below the set value (SV) are treated as the non-alarm status region (width of 20 °C in total).

→ For details on the loop breaking alarm function, refer to Section 6.12.

BFM No.				Description	Initial value	R/W	Backup
CH1	CH2	CH3	CH4				
#79	#119	#159	#199	Setting range : • PID control : 0 to Input span* ¹ (0 : Disabled) • Heating/cooling PID control : 0 (Not used)	0	R/W* ²	✓

- *1. Input span for internal temperature input
Scaling span for internal micro voltage input
External input span for external input

- *2. These buffer memories can be written only while standard PID control is being performed.

Example of operation

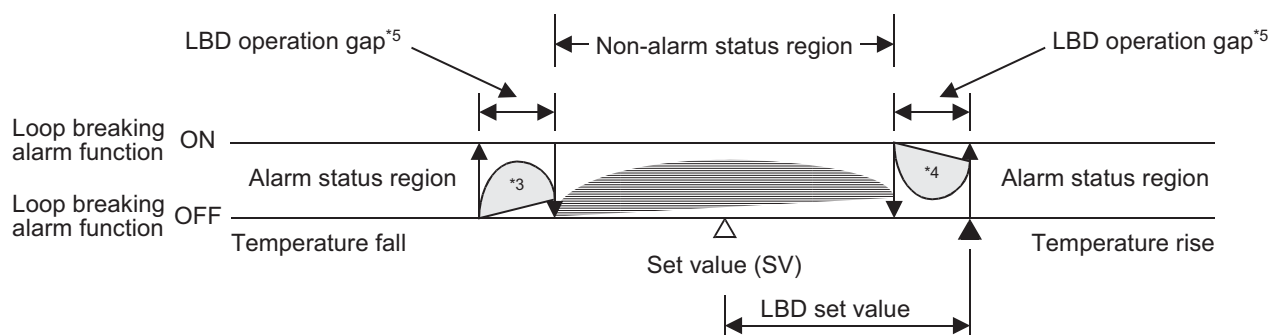

- *3. While the temperature is rising : Alarm status region
While the temperature is decreasing : Non-alarm status region
- *4. While the temperature is rising : Non-alarm status region
While the temperature is decreasing : Alarm status region
- *5. Loop breaking alarm dead zone operation gap
0.8°C for internal temperature input
0.8% of the scaling span for internal micro voltage input
0.8% of the external input span for external input

Caution

- When handling numbers containing decimal places, multiply the set value by 10.
- While the measured value (PV) is located within the non-alarm region, alarm is not issued even if the alarm condition is satisfied.
- In heating/cooling PID control, the loop breaking alarm dead zone is invalid.

1 Introduction
2 Specification
3 System Configuration
4 Installation
5 Wiring
6 Introduction of Functions
7 Alarm
8 Buffer Memory
9 Program Examples
10 Troubleshooting

8.2.44 [BFM#80][BFM#120][BFM#160][BFM#200] Micro voltage input scaling upper limit

To these buffer memories, set the micro voltage input scaling upper limit for setting the upper limit of the display range for the micro voltage input.

→ For details on the micro voltage input scaling lower limit, refer to Subsection 8.2.45.

BFM No.				Description	Initial value	R/W	Backup
CH1	CH2	CH3	CH4				
#80	#120	#160	#200	Setting range : -20000 to +20000 However, make sure that the span (absolute value of "Upper limit - Lower limit") is "20000" or less, and that the micro voltage input scaling upper limit is larger than the micro voltage input lower limit.	10000	R/W	✓

8.2.45 [BFM#81][BFM#121][BFM#161][BFM#201] Micro voltage input scaling lower limit

To these buffer memories, set the micro voltage input scaling lower limit for setting the lower limit of the display range for the micro voltage input.

→ For details on the micro voltage input scaling upper limit, refer to Subsection 8.2.44.

BFM No.				Description	Initial value	R/W	Backup
CH1	CH2	CH3	CH4				
#81	#121	#161	#201	Setting range : -20000 to +20000 However, make sure that the span (absolute value of "Upper limit - Lower limit") is "20000" or less, and that the micro voltage input scaling upper limit is larger than the micro voltage input lower limit.	0	R/W	✓

8.2.46 [BFM#82][BFM#122][BFM#162][BFM#202] External input range upper limit

To these buffer memories, set the external input range upper limit for setting the upper limit of the external input.

→ For details on the external input range lower limit, refer to Subsection 8.2.47.

BFM No.				Description	Initial value	R/W	Backup
CH1	CH2	CH3	CH4				
#82	#122	#162	#202	Setting range : -32000 to +32000 However, make sure that the external input range upper limit is larger than the external input range lower limit.	10000	R/W	✓

8.2.47 [BFM#83][BFM#123][BFM#163][BFM#203] External input range lower limit

To these buffer memories, set the external input range lower limit for setting the lower limit of the external input.

→ For details on the external input range upper limit, refer to Subsection 8.2.46.

BFM No.				Description	Initial value	R/W	Backup
CH1	CH2	CH3	CH4				
#83	#123	#163	#203	Setting range : -32000 to +32000 However, make sure that the external input range upper limit is larger than the external input range lower limit.	0	R/W	✓

8.2.48 [BFM#84][BFM#124][BFM#164][BFM#204] External output range upper limit

To these buffer memories, set the external output range upper limit for setting the upper limit of the external output.

→ For details on the external output range lower limit, refer to Subsection 8.2.49.

BFM No.				Description	Initial value	R/W	Backup
CH1	CH2	CH3	CH4				
#84	#124	#164	#204	Setting range : -32000 to +32000 However, make sure that the external output range upper limit is larger than the external output range lower limit.	10000	R/W	✓

8.2.49 [BFM#85][BFM#125][BFM#165][BFM#205] External output range lower limit

To these buffer memories, set the external output range lower limit for setting the lower limit of the external output.

→ For details on the external output range upper limit, refer to Subsection 8.2.48.

BFM No.				Description	Initial value	R/W	Backup
CH1	CH2	CH3	CH4				
#85	#125	#165	#205	Setting range : -32000 to +32000 However, make sure that the external output range upper limit is larger than the external output range lower limit.	0	R/W	✓

1

Introduction

2

Specification

3

System Configuration

4

Installation

5

Wiring

6

Introduction of Functions

7

Alarm

8

Buffer Memory

9

Program Examples

10

Troubleshooting

8.2.50 [BFM#86][BFM#126][BFM#166][BFM#206] Transistor output selection

To these buffer memories, set the function of transistor outputs built into the 4LC.
Available transistor output functions vary depending on the control mode setting.

→ For details on the control mode switch, refer to Section 6.2.

→ For details on the transistor output selection function, refer to Section 6.3.

BFM No.				Description	Initial value	R/W	Backup
CH1	CH2	CH3	CH4				
#86	#126	#166	#206	Setting range : 0 to 7 (Refer to the following)	0	R/W	✓

Transistor output selection

Transistor output selection set value	Control mode				
	0, 1 : PID control (Internal output)	2, 3 : PID control (External output)	4, 5 : Heating/cooling PID control (Internal output)*1	6, 7 : Heating/cooling PID control (External output)	
0	OUT1	CH1 control output	Normally OFF	CH1 heating control output	Normally OFF
	OUT2	CH2 control output	Normally OFF	CH1 cooling control output	Normally OFF
	OUT3	CH3 control output	Normally OFF	CH3 heating control output	Normally OFF
	OUT4	CH4 control output	Normally OFF	CH3 cooling control output	Normally OFF
1	OUT1	CH1 control output	CH1 control output	CH1 heating control output	CH1 heating control output
	OUT2	CH2 control output	CH2 control output	CH1 cooling control output	CH2 heating control output
	OUT3	CH3 control output	CH3 control output	CH3 heating control output	CH3 heating control output
	OUT4	CH4 control output	CH4 control output	CH3 cooling control output	CH4 heating control output
2	OUT1	CH1 control output	CH1 control output	CH1 heating control output	CH1 cooling control output
	OUT2	CH2 control output	CH2 control output	CH1 cooling control output	CH2 cooling control output
	OUT3	CH3 control output	CH3 control output	CH3 heating control output	CH3 cooling control output
	OUT4	CH4 control output	CH4 control output	CH3 cooling control output	CH4 cooling control output
3	OUT1	CH1 control output	CH1 alarm 1 state	CH1 heating control output	CH1 alarm 1 state
	OUT2	CH2 control output	CH2 alarm 1 state	CH1 cooling control output	CH2 alarm 1 state
	OUT3	CH3 control output	CH3 alarm 1 state	CH3 heating control output	CH3 alarm 1 state
	OUT4	CH4 control output	CH4 alarm 1 state	CH3 cooling control output	CH4 alarm 1 state
4	OUT1	CH1 control output	CH1 alarm 2 state	CH1 heating control output	CH1 alarm 2 state
	OUT2	CH2 control output	CH2 alarm 2 state	CH1 cooling control output	CH2 alarm 2 state
	OUT3	CH3 control output	CH3 alarm 2 state	CH3 heating control output	CH3 alarm 2 state
	OUT4	CH4 control output	CH4 alarm 2 state	CH3 cooling control output	CH4 alarm 2 state
5	OUT1	CH1 control output	CH1 alarm 3 state	CH1 heating control output	CH1 alarm 3 state
	OUT2	CH2 control output	CH2 alarm 3 state	CH1 cooling control output	CH2 alarm 3 state
	OUT3	CH3 control output	CH3 alarm 3 state	CH3 heating control output	CH3 alarm 3 state
	OUT4	CH4 control output	CH4 alarm 3 state	CH3 cooling control output	CH4 alarm 3 state
6	OUT1	CH1 control output	CH1 alarm 4 state	CH1 heating control output	CH1 alarm 4 state
	OUT2	CH2 control output	CH2 alarm 4 state	CH1 cooling control output	CH2 alarm 4 state
	OUT3	CH3 control output	CH3 alarm 4 state	CH3 heating control output	CH3 alarm 4 state
	OUT4	CH4 control output	CH4 alarm 4 state	CH3 cooling control output	CH4 alarm 4 state
7	OUT1	CH1 control output	CH1 loop breaking alarm state	CH1 heating control output	Normally OFF
	OUT2	CH2 control output	CH2 loop breaking alarm state	CH1 cooling control output	Normally OFF
	OUT3	CH3 control output	CH3 loop breaking alarm state	CH3 heating control output	Normally OFF
	OUT4	CH4 control output	CH4 loop breaking alarm state	CH3 cooling control output	Normally OFF

*1. When selecting the control mode "4" or "5", use external output for CH2 and CH4.

Caution

It is not possible to change the setting while control is being performed. If the setting is changed while control is being performed, the contents of setting are reflected when control is stopped.

8.2.51 [BFM#87][BFM#127][BFM#167][BFM#207] ST (startup tuning) execution command

To these buffer memories, set stop or execution of startup tuning.

Write "K0" to stop startup tuning.

Write "K1" to perform startup tuning.

→ For details on the ST (Startup tuning), refer to Section 6.9.

BFM No.				Description	Initial value	R/W	Backup
CH1	CH2	CH3	CH4				
#87	#127	#167	#207	0 : Stops ST (startup tuning) 1 : Performs ST (startup tuning)	0	R/W	-

Caution

- These buffer memories are valid only in standard PID control.
- If control is started while both the AT execution command buffer memory and the ST execution command buffer memory are set to "1", auto tuning is started.
- Startup tuning is not started if the conditions for performing startup tuning are not satisfied.
→ For details on the conditions for performing ST (startup tuning), refer to Subsection 6.9.2.

1

Introduction

2

Specification

3

System Configuration

4

Installation

5

Wiring

6

Introduction of Functions

7

Alarm

8

Buffer Memory

9

Program Examples

10

Troubleshooting

8.2.52 [BFM#208][BFM#214][BFM#220][BFM#226] Input type

To these buffer memories, set the input type.

BFM No.				Description	Initial value	R/W	Backup
CH1	CH2	CH3	CH4				
#208	#214	#220	#226	Input type (Refer to the following)	2	R/W ^{*1}	✓

*1. These buffer memories can be written only while control is stopped.

Input type

Set value	Input type	Input range	Unit	Set value	Input type	Input range	Unit
0	K	-200.0 to 200.0	0.1°C	24	B	0 to 1800	°C
1		-100.0 to 400.0	0.1°C	25		0 to 3000	°F
2		-100 to 1300	°C	26	N	0 to 1300	°C
3		-100 to 800	°F	27		0 to 2300	°F
4		-100 to 2400	°F	28	PLII	0 to 1200	°C
5	-200.0 to 200.0	0.1°C	29	0 to 2300		°F	
6	J	-100.0 to 400.0	0.1°C	30	W5Re/ W26Re	0 to 2300	°C
7		-100.0 to 800.0	0.1°C	31		0 to 3000	°F
8		-100 to 1200	°C	32	U	-200.0 to 600.0	0.1°C
9		-100 to 1600	°F	33		-300.0 to 700.0	0.1°F
10		-100 to 2100	°F	34		L	0.0 to 900.0
11	0 to 1700	°C	35	0 to 1600	°F		
12	R	0 to 3200	°F	36	Jpt100	-50.0 to 150.0	0.1°C
13	S	0 to 1700	°C	37		-200.0 to 500.0	0.1°C
14		0 to 3200	°F	38		-300.0 to 300.0	0.1°F
15	-200.0 to 200.0	0.1°C	39	-300 to 900		°F	
16	E	0 to 1000	°C	40	Pt100	-50.0 to 150.0	0.1°C
17		0 to 1800	°F	41		-200.0 to 600.0	0.1°C
18	T	-200.0 to 200.0	0.1°C	42		-300.0 to 300.0	0.1°F
19		-200.0 to 400.0	0.1°C	43	-300 to 1100	°F	
20		0.0 to 400.0	0.1°C	44	Pt1000	-200.0 to 650.0	0.1°C
21		-300.0 to 400.0	0.1°F	45		-328 to 1184	°F
22		-300.0 to 700.0	0.1°F	46	Micro voltage input	0 to 10	mV
23		0.0 to 700.0	0.1°F	47		0 to 100	mV

Caution

- It is not possible to change the setting while control is being performed. If the setting is changed while control is being performed, the contents of setting are reflected when control is stopped.
- When changing the input type, change the setting limiter values also so that the setting limiter values are within the input range.
 - For details on the setting limiter upper limit, refer to Subsection 8.2.40.
 - For details on the setting limiter lower limit, refer to Subsection 8.2.41.

8.2.53 [BFM#209 to #212][BFM#215 to #218][BFM#221 to #224][BFM#227 to #230] Alarm mode setting 1 to 4

The 4LC is equipped with 14 types of alarms. Four types of alarms (alarm 1 to alarm 4) are available in each channel in accordance with the application.

Set the alarm type by writing the alarm mode (0 to 14) to the alarm mode setting buffer memories for alarms 1 to 4 (each channel).

Values of alarms 1 to 4 can be set using the alarm set value buffer memories, and the alarm status can be checked in the status of alarm bits (b4 to b7) for alarms 1 to 4 of the event buffer memory.

→ For details on the alarm function, refer to Chapter 7.

→ For details on the event, refer to Subsection 8.2.2.

→ For details on the alarm setting value, refer to Subsection 8.2.16.

BFM No.				Description	Initial value	R/W	Backup
CH1	CH2	CH3	CH4				
Alarm 1 mode setting							
#209	#215	#221	#227	Setting range : 0 to 14 (Refer to the following)	0	R/W ^{*1}	✓
Alarm 2 mode setting							
#210	#216	#222	#228	Setting range : 0 to 14 (Refer to the following)	0	R/W ^{*1}	✓
Alarm 3 mode setting							
#211	#217	#223	#229	Setting range : 0 to 14 (Refer to the following)	0	R/W ^{*1}	✓
Alarm 4 mode setting							
#212	#218	#224	#230	Setting range : 0 to 14 (Refer to the following)	0	R/W ^{*1}	✓

*1. These buffer memories can be written only while control is stopped.

Alarm mode (0 to 14)

Alarm mode	Alarm type	Description
0	Alarm function OFF	Alarm function is disabled.
1	Upper limit input value alarm	When measured value (PV) is more than alarm set value, an alarm is issued.
2	Lower limit input value alarm	When measured value (PV) is less than alarm set value, an alarm is issued.
3	Upper limit deviation alarm	When deviation (= Measured value (PV) - Set value (SV)) is more than alarm set value, an alarm is issued.
4	Lower limit deviation alarm	When deviation (= Measured value (PV) - Set value (SV)) is less than alarm set value, an alarm is issued.
5	Upper/lower limit deviation	When absolute deviation (= Measured value (PV) - Set value (SV)) is more than alarm set value, an alarm is issued.
6	Range alarm	When absolute deviation (= Measured value (PV) - Set value (SV)) is less than alarm set value, an alarm is issued.
7	Upper limit input value alarm with wait	When measured value (PV) is more than alarm set value, an alarm is issued. However, when control is started the measured value is ignored.
8	Lower limit input value alarm with wait	When measured value (PV) is less than alarm set value, an alarm is issued. However, when control is started the measured value is ignored.
9	Upper limit deviation value alarm with wait	When deviation (= Measured value (PV) - Set value (SV)) is more than alarm set value, an alarm is issued. However, when control is started the measured value is ignored.
10	Lower limit deviation value alarm with wait	When deviation (= Measured value (PV) - Set value (SV)) is less than alarm set value, an alarm is issued. However, when control is started the measured value is ignored.
11	Upper/lower limit deviation value alarm with wait	When absolute deviation (= Measured value (PV) - Set value (SV)) is more than alarm set value, an alarm is issued. However, when control is started the measured value is ignored.
12	Upper limit deviation value alarm with re-wait	When deviation (= Measured value (PV) - Set value (SV)) is more than alarm set value, an alarm is issued. However, when control is started and when set value is changed the measured value is ignored.
13	Lower limit deviation value alarm with re-wait	When deviation (= Measured value (PV) - Set value (SV)) is less than alarm set value, an alarm is issued. However, when control is started and when set value is changed the measured value is ignored.

Alarm mode	Alarm type	Description
14	Upper/lower limit deviation value alarm with re-wait	When absolute deviation (= Measured value (PV) - Set value (SV)) is more than alarm set value, an alarm is issued. However, when control is started and when set value is changed the measured value is ignored.

Caution

It is not possible to change the setting while control is being performed.
If the setting is changed while control is being performed, the contents of setting are reflected when control is stopped.

8.2.54 [BFM#232] Cooling method setting

To these buffer memories, set the cooling method for performing heating/cooling PID control. Select the cooling method among "air cooling type", "water cooling type" and "cooling gain linear type" in accordance with the cooling unit.

Because the cooling characteristics are considerably different between the air cooling method and the water cooling method, PID constants suitable to the cooling unit can be obtained by setting the cooling method before starting auto tuning.

The selected cooling method is applied to all channels.

→ For details on the cooling method, refer to Subsection 6.6.4.

BFM No.				Description	Initial value	R/W	Backup
CH1	CH2	CH3	CH4				
		#232		Setting range : • PID control : 0 (Not used) • Heating/cooling PID control : 0 : Air cooling type 1 : Water cooling type 2 : Cooling gain linear type	0	R/W*1	✓

*1. GR1 and GR2 can be written only while heating/cooling PID control is being performed.

Caution

Set the cooling method before performing auto tuning because the setting affects arithmetic operation results of PID constants acquired by auto tuning.

8.2.55 [BFM#233] Alarm dead band setting

To these buffer memories, set the dead zone for alarms 1 to 4.

The setting is applied to alarms 1 to 4 in all channels.

When the measured value (PV) is around the alarm set value, the alarm status and non-alarm status may be repeated due to input fluctuations.

By setting the alarm dead zone, it is possible to prevent repetitions of the alarm status and non-alarm status.

→ For details on the alarm function, refer to Chapter 7.

→ For details on the measured value (PV), refer to Subsection 8.2.3.

→ For details on the alarm setting value, refer to Subsection 8.2.16.

→ For details on the alarm mode setting, refer to Subsection 8.2.53.

BFM No.				Description	Initial value	R/W	Backup
CH1	CH2	CH3	CH4				
#233				Setting range : 0 to 100 (0.0 to 10.0% of span)*1	10	R/W	✓

- *1. Input span for internal temperature input
- Scaling span for internal micro voltage input
- External input span for external input

Example of operation 1 (Upper limit input value alarm, Upper limit deviation alarm)

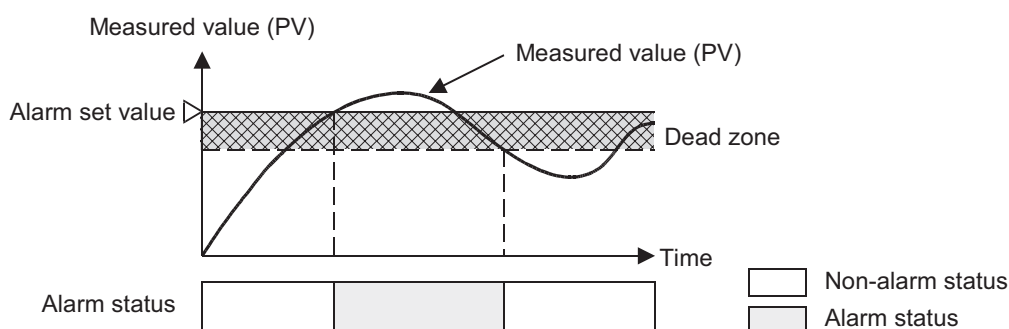

Example of operation 2 (Lower limit input value alarm, Lower limit deviation alarm)

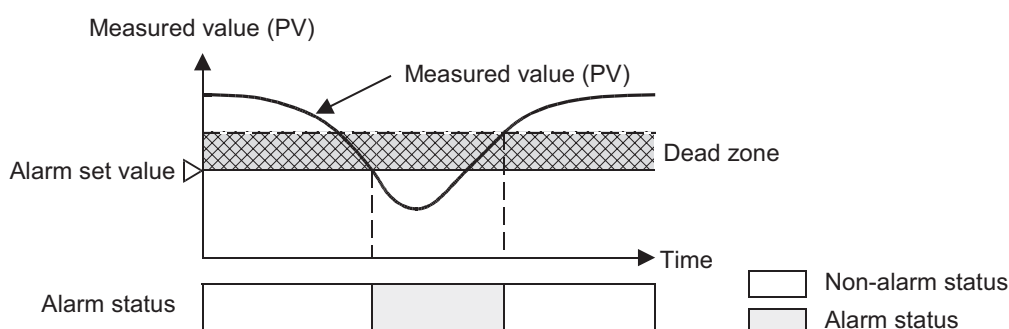

Example of operation 3 (Upper/lower limit deviation)

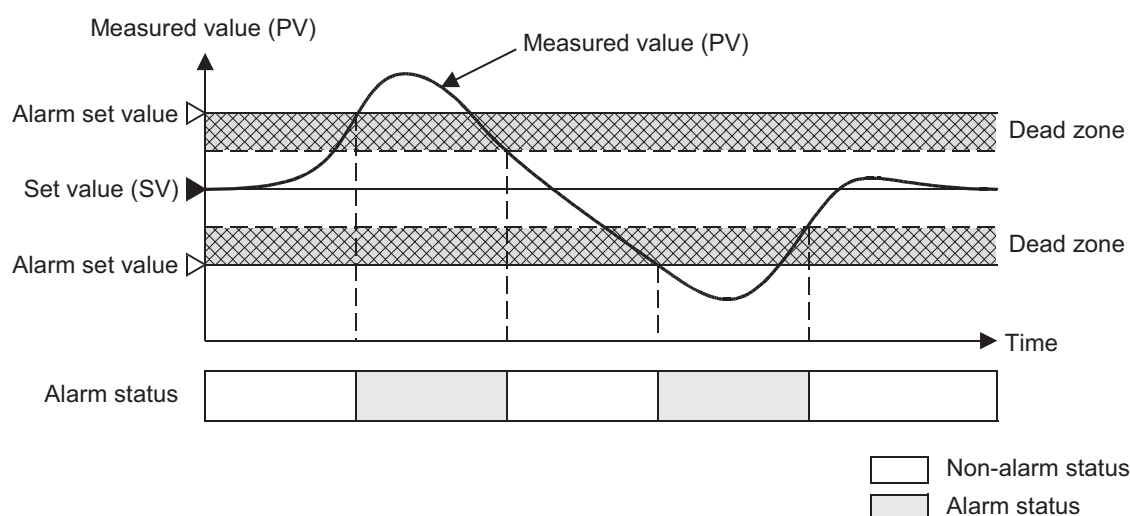

Caution

Handling numbers containing decimal places. The set value should be the actual value multiplied by 10.

8.2.56 [BFM#234] Alarm delay count

To this buffer memory, set the number of times of alarm delay for alarms 1 to 4.

The setting is applied to alarms 1 to 4 in all channels.

The alarm delay function keeps the non-alarm status until the number of times of input sampling exceeds the preset number of times of alarm delay after the deviation between the measured value (PV) and the set value (SV) reaches the alarm set value.

If the deviation remains in the alarm range until the number of times of input sampling exceeds the number of times of alarm delay, an alarm is issued.

The input sampling period is 0.25 sec for the number of times of alarm delay.

- For details on the alarm function, refer to Chapter 7.
- For details on the measured value (PV), refer to Subsection 8.2.3.
- For details on the set value (SV), refer to Subsection 8.2.15.
- For details on the alarm setting value, refer to Subsection 8.2.16.
- For details on the alarm mode setting, refer to Subsection 8.2.53.

BFM No.				Description	Initial value	R/W	Backup
CH1	CH2	CH3	CH4				
#234				Setting range : 0 to 30000	0	R/W	✓

Example of operation (When the number of alarm delays, is set to 5 times)

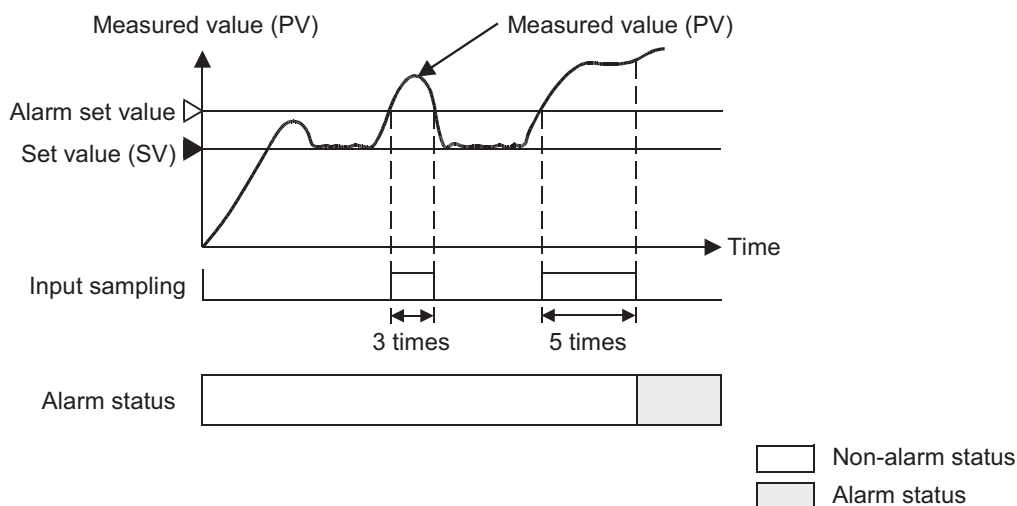

8.2.57 [BFM#235] Number of times of heater disconnection alarm delay/ Number of times of current error detection when output is OFF delay

To this buffer memory, set the number of times of delay for detecting heater disconnection or detecting current abnormality while the output is OFF.

The setting is applied to all channels.

If abnormality occurs continuously exceeding the preset number of times in the heater current measured value or the current value while the output is OFF, an alarm is issued.

The sampling period is 500ms for the heater current measured value and the current while the output is OFF.

→ For details on the heater disconnection alarm, refer to Section 6.11.

→ For details on the heater current measured value, refer to Subsection 8.2.7.

BFM No.				Description	Initial value	R/W	Backup
CH1	CH2	CH3	CH4				
#235				Setting range : 3 to 255 (times)	3	R/W	✓

8.2.58 [BFM#236] Temperature rise completion range setting

To this buffer memory, set the temperature rise completion range.

The setting is applied to all channels.

Set the temperature range in which temperature rise is regarded as completed for the set value (SV).

When temperature rise is completed, the temperature rise completion flag (b15) of the event buffer memory turns ON.

By setting the temperature rise completion soak time, it is possible to delay the time until the temperature rise completion flag turns ON after the measured value (PV) enters the temperature rise completion range.

Set integers from 1 to 100 for temperature. (The setting value does not depend on input type.)

→ For details on the event, refer to Subsection 8.2.2.

→ For details on the temperature rise completion soak time, refer to Subsection 8.2.59.

BFM No.				Description	Initial value	R/W	Backup
CH1	CH2	CH3	CH4				
#236				Setting range : 1 to 100 (1 to 100°C/°F/digit)	10	R/W	✓

Example of operation

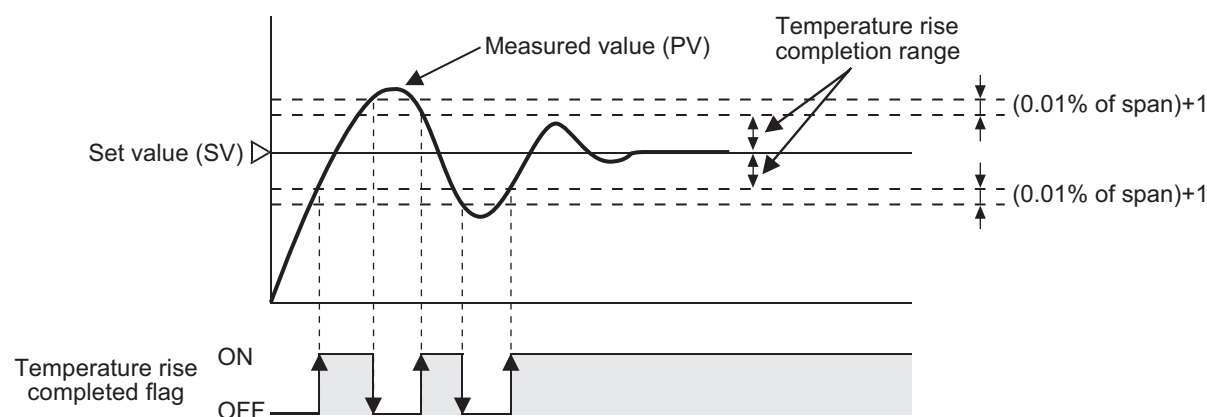

Caution

The temperature rise completion range is actually judged in a upper range portion and lower range portion of the set value (SV). Practically, the actual range width is doubled. (If the temperature rise completion range value is set to "10°C", 10°C above the set value and 10°C below the set value are treated as the temperature rise completion range (width of 20°C in total)).

8.2.59 [BFM#237] Temperature rise completion soak time

To this buffer memory, set the temperature rise completion soak time.
The setting is applied to all channels.

When the measured value (PV) remains in the temperature rise completion range until the temperature rise completion soak time is finished, the temperature rise completion flag (b15) of the event buffer memory turns ON.

→ For details on the event, refer to Subsection 8.2.2.

→ For details on the temperature rise completion range, refer to Subsection 8.2.58.

BFM No.				Description	Initial value	R/W	Backup
CH1	CH2	CH3	CH4				
#237				Setting range : 0 to 3600 (sec.)	0	R/W	✓

Example of operation 1 (When the temperature rise completion soak time is set to any positive value)

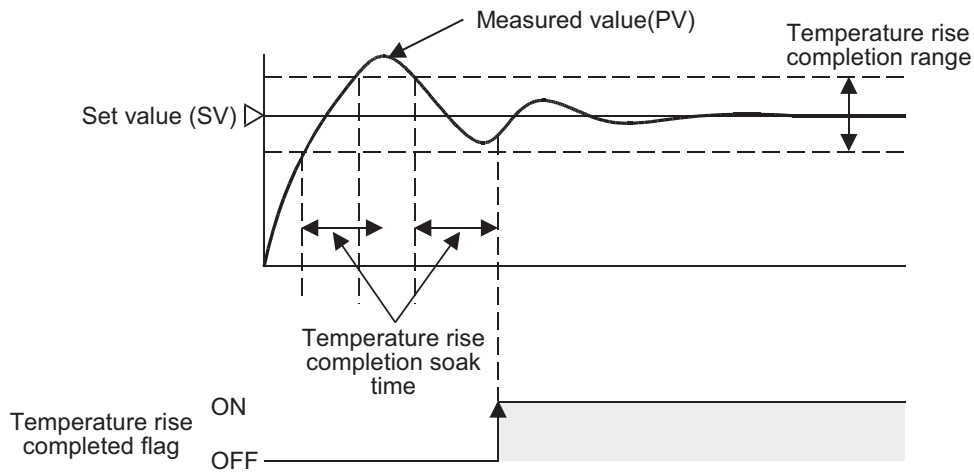

Example of operation 2 (When the temperature rise completion soak time is set to "0")

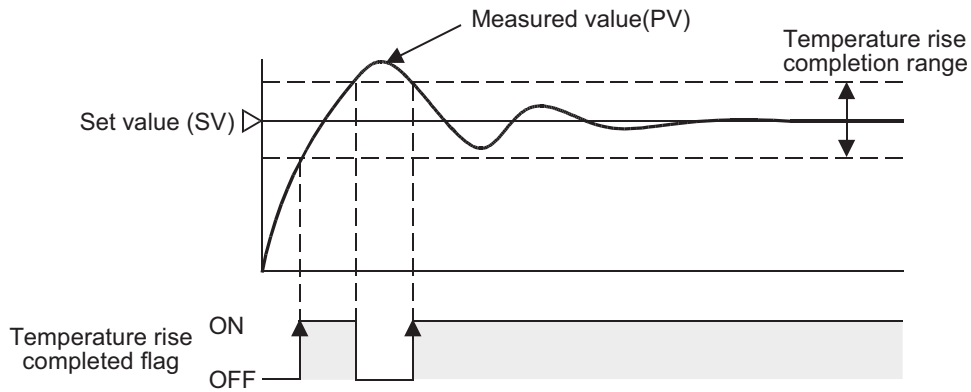

Point

When the measured value (PV) is not stable even after it has reached the temperature rise completion range, the temperature rise completion soak time gives the waiting time for the judgment of temperature rise completion.

8.2.60 [BFM#238] CT monitor method switch

To this buffer memory, enter the heater current measured value display method.

The setting is applied to all channels.

The control output (MV) turns ON and OFF repeatedly while control is being performed, and the current at control output ON and the current at control output OFF are displayed alternately.

If the control output (MV) cycle is short, the heater current measured value display is not stable, and difficult to read.

To cope with such a phenomenon, the display method can be changed.

Write "K0" to alternately display the current at control output ON and the current at control output OFF.

Write "K1" to display only the current at control output ON.

While the control output is OFF, the current at control output ON remains displayed.

→ For details on the heater current measured value, refer to Subsection 8.2.7.

→ For details on the control output cycle setting, refer to Subsection 8.2.34.

BFM No.				Description	Initial value	R/W	Backup
CH1	CH2	CH3	CH4				
#238				0 : Monitors both ON current and OFF current 1 : Monitors only ON current	0	R/W	✓

Caution

The current at control output OFF is displayed without regard to the setting of this buffer memory while control is stopped.

8.2.61 [BFM#239] CT ratio setting

To this buffer memory, set the number of secondary turns in the used current detector (CT).

The setting is applied to all channels.

BFM No.				Description	Initial value	R/W	Backup
CH1	CH2	CH3	CH4				
#239				Setting range : 1 to 9999*1	800	R/W	✓

*1. Make sure that the set value satisfies the following expression:

$$\left(\frac{\text{Maximum value of postulated effective current} \times 1.1}{\text{CT ratio setting}} \right)^2 \times 3.77 \leq 0.715$$

Reference examples of current detector (CT)

CT type	CT ratio set value
CTL-6-P-H	800
CTL-12-S36-8	800
CTL-12-S56-10	1000

Manufactured by U.R.D. Co., Ltd.

Caution

The current value is not displayed correctly if the number of secondary turns in the used current detector (CT) and CT ratio setting are different.

8.2.62 [BFM#240, #241] Control mode switch

To these buffer memories, set the control type (standard PID control, two-position control, manual control, cascade control or heating/cooling control) and used inputs/outputs (external or internal) for each control group.

Control groups are classified into group 1 (CH1 and CH2) and group 2 (CH3 and CH4).

The setting for control group 1 (GR1) is applied to both CH1 and CH2.

The setting for control group 2 (GR2) is applied to both CH3 and CH4.

→ For details on the control mode, refer to Section 6.2.

BFM No.				Description	Initial value	R/W	Backup
CH1	CH2	CH3	CH4				
GR1		GR2					
#240		#241		Setting range : 0 to 7 (Refer to the following)	0	R/W*1	✓

*1. These buffer memories can be written only while control is stopped.

Control mode

Control mode	Control type	Input	Output
0	PID control	Internal	Internal
1		External	
2	Two-position control	Internal	External
3		External	
4	Manual control	Internal	Internal
5		External	
6	Cascade control	Internal	External
7		External	

- When internal input is selected
The 4LC performs control using measured values detected through inputs built into the 4LC.
- When external input is selected
The 4LC performs control using values stored in the external input value buffer memories (BFM#25 to BFM#28) without using inputs built into the 4LC.
- When internal output is selected
The 4LC performs control using transistor outputs built into the 4LC. However, in heating/cooling PID control, the control output of CH2 and CH4 should use an external output.
- When external output is selected
The 4LC performs control using values stored in the external output value monitor/heating external output value monitor buffer memories (BFM#32 to BFM#35) and cooling external output value monitor buffer memories (BFM#36 to BFM#39) without using transistor outputs built into the 4LC. The transistor output built into the 4LC is controllable when transistor output selections 1 and 2 are chosen. Additionally the outputs can also be used as alarm outputs.
→ For details on the external input value, refer to Subsection 8.2.8.
→ For details on the external output value, refer to Subsection 8.2.11 or 8.2.12.
→ For details on the transistor output selection, refer to Subsection 8.2.50.

Caution

It is not possible to change the setting while control is being performed.

If the setting is changed while control is being performed, the contents of setting are changed when control is stopped.

8.2.63 [BFM#242, #243] SV tracking selection

The SV tracking selection function makes the slave channel set value (SV) track the set value (value stored in the set value monitor buffer memory) just before changeover to cascade OFF when the cascade control function is changed from ON to OFF.

Write "K0" to disable the tracking function.

Write "K1" to enable the tracking function.

Control group 1 (GR1) : The setting is applied to CH1 and CH2.

Control group 2 (GR2) : The setting is applied to CH3 and CH4.

→ For details on the cascade control, refer to Section 6.7.
→ For details on the set value monitor, refer to Subsection 8.2.13.
→ For details on the set value (SV), refer to Subsection 8.2.15.

BFM No.				Description	Initial value	R/W	Backup
CH1	CH2	CH3	CH4				
GR1		GR2					
#242		#243		Setting range : • PID control : 0 : Disable 1 : Enable • Heating/cooling PID control : 0 (Not used)	1 ^{*1}	R/W ^{*2}	-

*1. 0 in the case of heating/cooling PID control.

*2. These buffer memories can be written only while standard PID control is being performed.

Example of operation 1 (When SV tracking is provided)

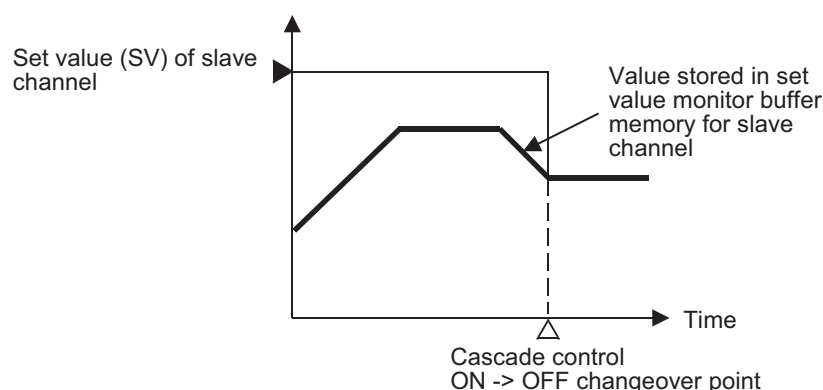

Example of operation 2 (When SV tracking is not provided)

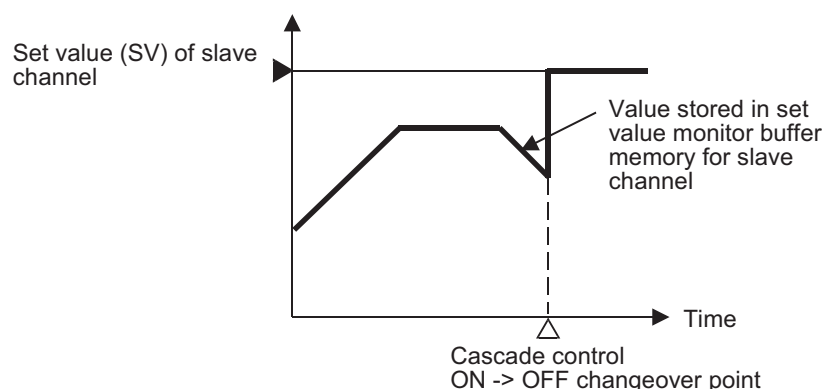

Point

This function prevents drastic change in the set value (SV) caused when the cascade control function is changed from ON to OFF.

1	Introduction
2	Specification
3	System Configuration
4	Installation
5	Wiring
6	Introduction of Functions
7	Alarm
8	Buffer Memory
9	Program Examples
10	Troubleshooting

8.2.64 [BFM#244, #245] Cascade ON/OFF

Using these buffer memories, turn ON or OFF cascade control.

Write "K0" to turn OFF cascade control.

Write "K1" to turn ON cascade control.

When cascade control is changed over from OFF to ON, the control output from the master channel is changed over without bump. When cascade control is changed over from ON to OFF, the resulted operation varies depending on the setting of the SV tracking selection buffer memory.

Control group 1 (GR1) : The setting is applied to CH1 and CH2.

Control group 2 (GR2) : The setting is applied to CH3 and CH4.

→ For details on the cascade control, refer to Section 6.7.

→ For details on the SV tracking selection, refer to Subsection 8.2.64.

BFM No.				Description	Initial value	R/W	Backup
CH1	CH2	CH3	CH4				
GR1		GR2					
#244		#245		Setting range : • PID control : 0 : Cascade OFF 1 : Cascade ON • Heating/cooling PID control : 0 (Not used)	0	R/W ^{*1}	-

*1. These buffer memories can be written only while standard PID control is being performed.

Caution

- Cascade control is disabled when heating/cooling PID control is selected.
- Auto tuning and startup tuning are disabled while cascade control is being performed.

8.2.65 [BFM#246, #247] Cascade gain

To these buffer memories, set the gain used during cascade control when the control output (MV) from the master channel is added to the cascade bias, converted into the full scale of the slave channel input range, and then converted into the cascade signal.

Control group 1 (GR1) : The setting is applied to CH1 and CH2.

Control group 2 (GR2) : The setting is applied to CH3 and CH4.

→ For details on the cascade control, refer to Section 6.7.

→ For details on the cascade bias, refer to Subsection 8.2.66.

BFM No.				Description	Initial value	R/W	Backup
CH1	CH2	CH3	CH4				
GR1		GR2					
#246		#247		Setting range : • PID control : -10000 to +10000 (-10.000 to +10.000 times) • Heating/cooling PID control : 0 (Not used)	1000 ^{*2}	R/W ^{*1}	✓

*1. These buffer memories can be written only while standard PID control is being performed.

*2. 0 in the case of heating/cooling PID control.

Caution

Handling numbers containing decimal places. The set value should be the actual value multiplied by 1000.

8.2.66 [BFM#248, #249] Cascade bias

To these buffer memories, set the cascade bias added to the control output (MV) from the master channel during cascade control.

Control group 1 (GR1) : The setting is applied to CH1 and CH2.

Control group 2 (GR2) : The setting is applied to CH3 and CH4.

→ For details on the cascade control, refer to Section 6.7.

→ For details on the cascade gain, refer to Subsection 8.2.65.

BFM No.				Description	Initial value	R/W	Backup
CH1	CH2	CH3	CH4				
GR1		GR2					
#248		#249		Setting range : • PID control : -1000 to +1000 (-100.0% to +100.0%) • Heating/cooling PID control : 0 (Not used)	0	R/W*1	✓

*1. These buffer memories can be written only while standard PID control is being performed.

Caution

Handling numbers containing decimal places. The set value should be the actual value multiplied by 10.

8.2.67 [BFM#250, #251] Cascade monitor

These buffer memories store the value from the master channel which is converted using the cascade gain and cascade bias.

The value stored in a cascade monitor is as follows.

$$\text{Cascade monitor value} = [\text{Master channel control output value (MV)} \times \text{cascade gain} + \text{cascade bias}] \times \text{slave channel of input span}$$

Control group 1 (GR1) : The setting is applied to CH1 and CH2.

Control group 2 (GR2) : The setting is applied to CH3 and CH4.

→ For details on the cascade control, refer to Section 6.7.

→ For details on the cascade gain, refer to Subsection 8.2.65.

→ For details on the cascade bias, refer to Subsection 8.2.66.

BFM No.				Description	Initial value	R/W	Backup
CH1	CH2	CH3	CH4				
GR1		GR2					
#250		#251		Display range : -32000 to +32000	0	R	-

Caution

These buffer memories store "0" while cascade control is OFF.

1

Introduction

2

Specification

3

System Configuration

4

Installation

5

Wiring

6

Introduction of Functions

7

Alarm

8

Buffer Memory

9

Program Examples

10

Troubleshooting

8.2.68 [BFM#252] Set value range error address

When a value written to each buffer memory is outside the setting range, the set value range error flag (b1) turns ON, and this buffer memory BFM#252 stores the buffer memory number where the error has occurred. The setting is applied to all channels.

Check the setting range of the memory number where the error has occurred, set a normal value, and then execute the error reset command.

→ For details on the flag, refer to Subsection 8.2.1.

→ For details on the error reset command, refer to Subsection 8.2.69.

BFM No.				Description	Initial value	R/W	Backup
CH1	CH2	CH3	CH4				
#252				0 : Normal 1 to 255 : Setting error address	0	R	-

Caution

This buffer memory stores "0" when no error has occurred.

8.2.69 [BFM#253] Error reset command

Reset errors using this buffer memory.

Write "K1" to reset existing errors.

The contents of errors can be checked using flags.

The setting is applied to all channels.

→ For details on the flag, refer to Subsection 8.2.1.

→ For details on the set value range error address, refer to Subsection 8.2.68.

BFM No.				Description	Initial value	R/W	Backup
CH1	CH2	CH3	CH4				
#253				0 : Performs nothing 1 : Resets errors	0	R/W	-

Caution

- Set "K1" for 0.25 sec or more to execute the error reset command.
- This buffer memory (Error reset command) does not become "0" automatically after errors are reset. Write "K0" to this buffer memory after errors are reset.

8.2.70 [BFM#254] Set value backup command

Back up the set values using this buffer memory.

Write "K1" to write the set values of the backup target buffer memories to the EEPROM built into the 4LC.

The setting is applied to all channels.

The EEPROM stores initial values at shipment.

The backup target buffer memories can be checked using the buffer memory list.

→ For details on the buffer memory list, refer to Section 8.1.

BFM No.				Description	Initial value	R/W	Backup
CH1	CH2	CH3	CH4				
#254				0 : Normal 1 : Starts to write EEPROM	0	R/W	-

Example of operation

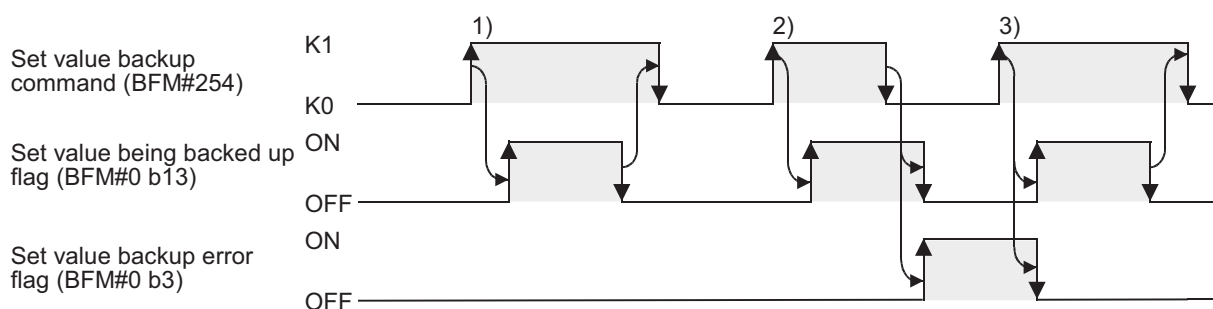

Explanation of operation

- When "K1" is written to BFM#254 (Set value backup command), the "Set value being backed up" flag turns ON. When backup of the set values is completed, the "Set value being backed up" flag turns OFF. After that, write "0" (for setting to OFF) to BFM#254 (Set value backup command).
- If BFM#254 (Set value backup command) is set to OFF while the "Set value being backed up" flag is ON, the "Set value backup error" flag turns ON. In this case, perform the operation described in 3).
- If BFM#254 (Set value backup command) is set to OFF while the "Set value backup error" flag is ON, the "Set value being backed up" flag turns ON. When backup of the set values is completed, the "Set value being backed up" flag turns OFF. After that, write "0" (for setting to OFF) to BFM#254 (Set value backup command).

→ For details on the flag, refer to Subsection 8.2.1.

Point

When the power is turned ON, the 4LC transfers the contents of the EEPROM to the buffer memories for using them as the set values for control. Accordingly, if the set values are written once to the EEPROM, it is unnecessary from the next power ON to write the set values to the buffer memory. The 4LC can start control immediately when the control start/stop changeover buffer is set to "1: Starts control".

→ For details on the control start/stop changeover, refer to Subsection 8.2.9.

Caution

- This buffer memory (Set value backup command) does not become "0" automatically after backup is completed. Write "K0" to this buffer memory after backup is completed.
- If the power is turned OFF once and ON again when a set value backup error has occurred, all data is reset to the initial value.
- The set values are not backed up when a set value range error has occurred.

8.2.71 [BFM#255] Initialization command

Initialize the set values using this buffer memory.

The initialization range varies depending on the set value.

Write "K1" to initialize all buffer memories.

Write "K2" to initialize buffer memories #48 to #207, #232 and #242 to #247 in accordance with the input type (in the case of internal input) and control mode.

The setting is applied to all channels.

Buffer memories are not initialized when "K0" is written.

→ For details on the input type, refer to Subsection 8.2.52.

→ For details on the control mode switch, refer to Subsection 8.2.62.

BFM No.				Description	Initial value	R/W	Backup
CH1	CH2	CH3	CH4				
		#255		0 : Does not initialize buffer memories. 1 : Initialize all buffer memories. 2 : Initializes buffer memories BFM#48 to #207, #232 and #242 to #247 in accordance with the input type (in the case of internal input) and control mode.	0	R/W ^{*1}	-

*1. These buffer memories can be written only while control is stopped.

Example of operation

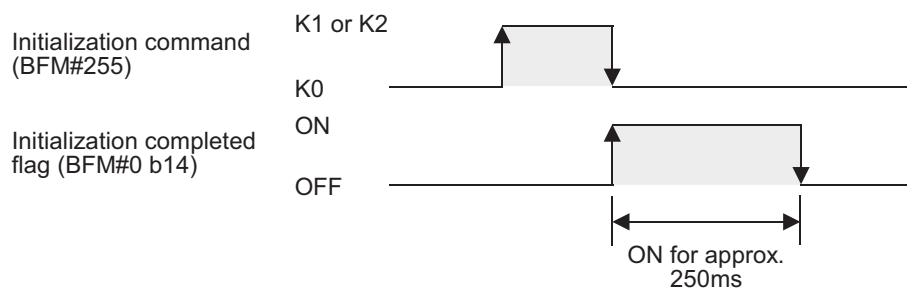

Explanation of operation

- 1) When "K1" or "K2" is written to BFM#255 (Initialization command), the set values are initialized.
- 2) When initialization is completed, BFM#255 becomes "K0", and the "Initialization completed" flag turns ON and remains ON for approximately 250ms.

→ For details on the flag, refer to Subsection 8.2.1.

Caution

- Do not write or read buffer memories while the "Initialization completed" flag is ON.
- Initialization is disabled while control is being performed or while the set values are backed up.

9. Program Examples

STARTUP AND MAINTENANCE PRECAUTIONS



- Make sure to connect the battery correctly. Do not charge, disassemble, heat, short-circuit, or expose the battery to fire. Doing so may rupture or ignite it.
- Do not touch any terminal while the PLC's power is on. Doing so may cause electric shock or malfunctions.
- Before modifying or disrupting the program in operation or running the PLC, carefully read through this manual and the associated manuals and ensure the safety of the operation. An operation error may damage the machinery or cause accidents.

STARTUP AND MAINTENANCE PRECAUTIONS

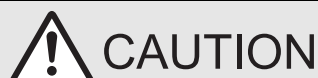

- Do not disassemble or modify the PLC. Doing so may cause fire, equipment failures, or malfunctions. For repair, contact your local Mitsubishi Electric distributor.
- Turn off the power to the PLC before attaching or detaching the following devices. Failure to do so may cause device failures or malfunctions.
 - Peripheral devices, display modules, expansion boards and special adapters
 - I/O extension units/blocks, FX Series terminal block and the special function units/blocks
 - Battery and memory cassette

1

Introduction

2

Specification

3

System Configuration

4

Installation

5

Wiring

6

Introduction of Functions

7

Alarm

8

Buffer Memory

9

Program Examples

10

Troubleshooting

9.1 Reading/Writing Buffer Memory

9.1.1 Assigned unit number

1. Assigned unit number

The unit number for the 4LC is automatically assigned No.0 to No.7 starting from the special function unit/block closest to the PLC main unit.

- In the FX3G, FX3U, FX3UC (D, DSS) series

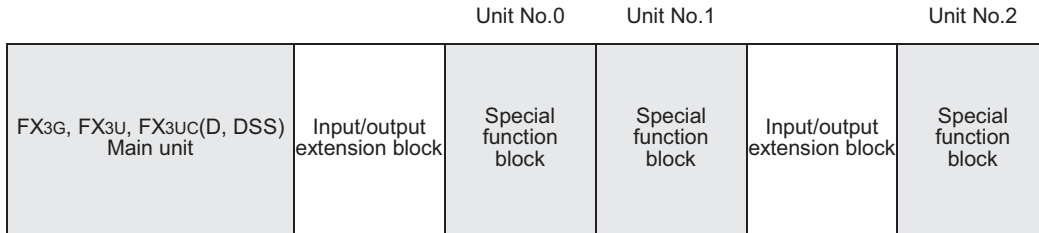

- In the FX3UC-32MT-LT, FX3UC-32MT-LT-2 series

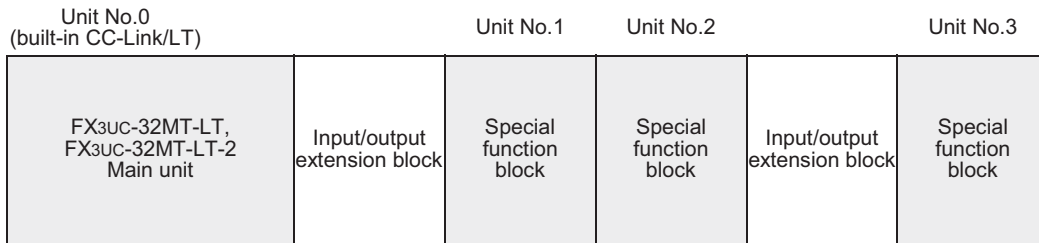

9.1.2 How to read/write from/to buffer memory

To read/write from/to buffer memory in the 4LC, use the FROM/TO instructions or applied instructions that directly specify the buffer memory.

To directly specify the buffer memory, FX3U/FX3UC PLC applicable software is required.

→ **For details of applied instructions, bit specification of word devices and direct specification of the buffer memory, refer to the PROGRAMMING MANUAL.**

Point

Buffer memory that is assigned in 32 bits must use 32-bit instructions to read/write.

Data cannot be correctly read/written from/to buffer memory assigned in 32 bits if 16-bit read/write instructions are used.

1. How to read and write numeric values

- Direct specification of buffer memory

Specify the buffer memory directly as the source or destination in applied instructions, and then read or write the contents of the buffer memory.

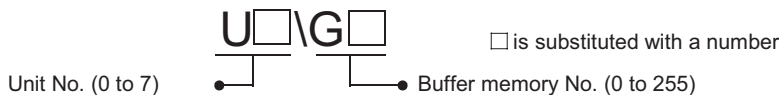

- Reading and transferring numeric values to data registers

In the program below, the contents of the buffer memory (BFM#5) in the unit No. 1 are read and transferred to data register (D0).

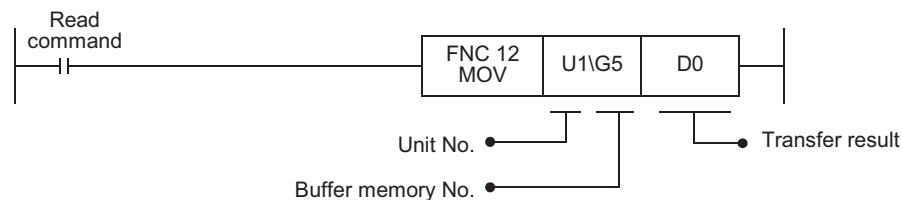

- b) Writing numeric values to the buffer memory
In the program below, "K32,000" is written to the buffer memory (BFM#25) in the unit No. 1.

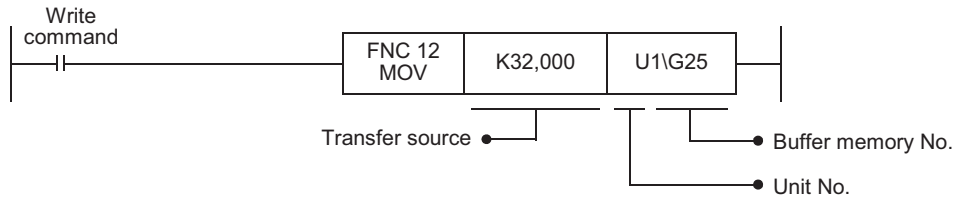

- c) Writing the current value of data registers to the buffer memory
In the program below, the current value of data register (D10) is written to the buffer memory (BFM#25) in the unit No. 1.

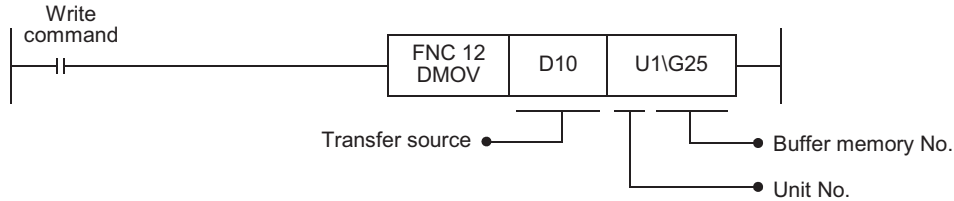

- 2) FROM/TO instructions (conventional method)
Read and write the contents of the buffer memory using the FROM/TO instructions.

- a) Reading and transferring numeric values to data registers (FROM instruction)
In the program below, the contents of the buffer memory (BFM#5) in the unit No. 1 are read and transferred to data registers (D0).

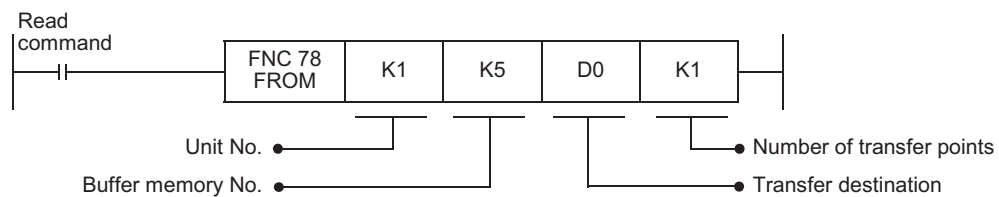

- b) Writing numeric values to the buffer memory (TO instruction)
In the program below, "K32,000" is written to the buffer memory (BFM#25) in the unit No. 1.

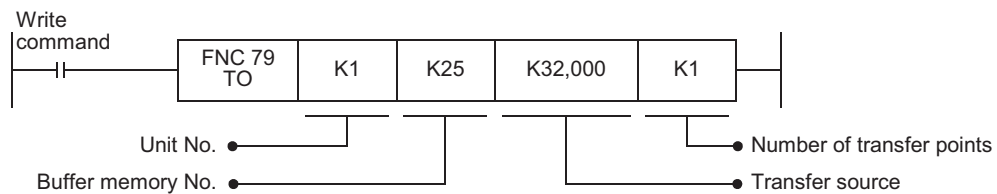

- c) Writing the current value of data registers to the buffer memory (TO instruction)
In the program below, the current value of data register (D10) is written to the buffer memory (BFM#25) in the unit No. 1.

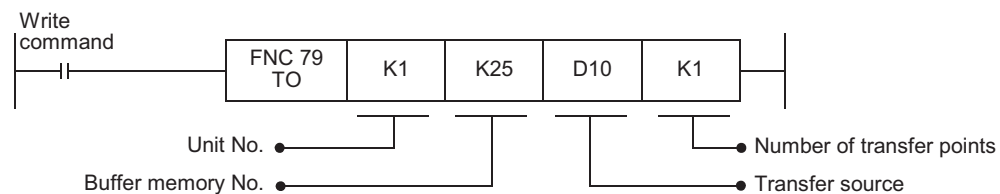

2. How to read and write the bit information such as flag and event

1) Direct specification of buffer memory

Specify the buffer memory directly as the source in applied instructions, and read or write the contents.



Unit No. (0 to 7) Buffer memory No. (0 to 255)

a) Reading and transferring the bit information to auxiliary relays

In the program below, the contents of the buffer memory (BFM#0) in the unit No. 1 are read and transferred to auxiliary relays (M40 to M55).

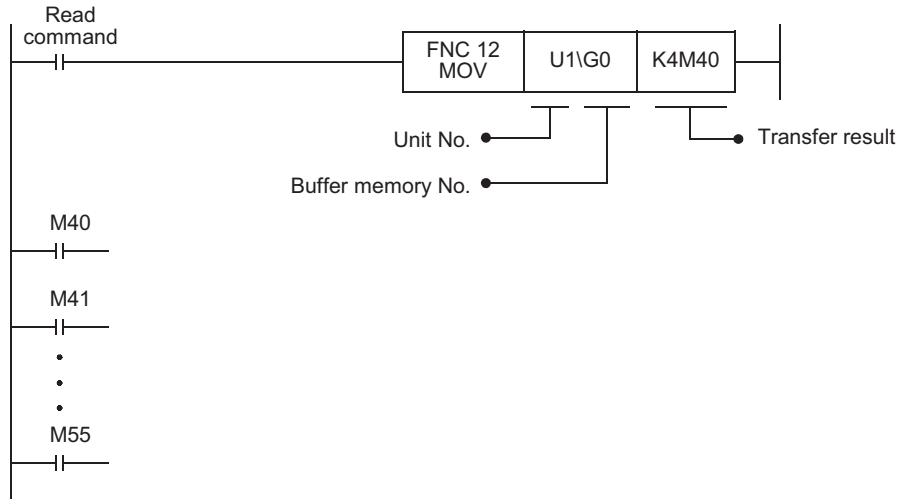

b) Reading and transferring the bit information to data registers

In the program below, the contents of the buffer memory (BFM#0) in the unit No. 1 are read and transferred to a data register (D200). The read bit information is used in bit specification of word devices.

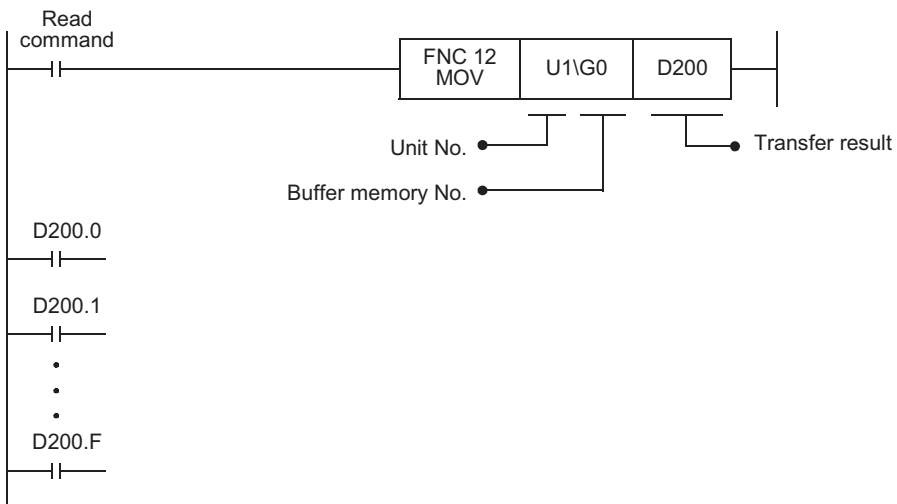

- c) Writing the bit information of auxiliary relays to the buffer memory
In the program below, the ON/OFF status of auxiliary relays (M20 to M35) is written to the buffer memory (BFM#518) in the unit No. 0.

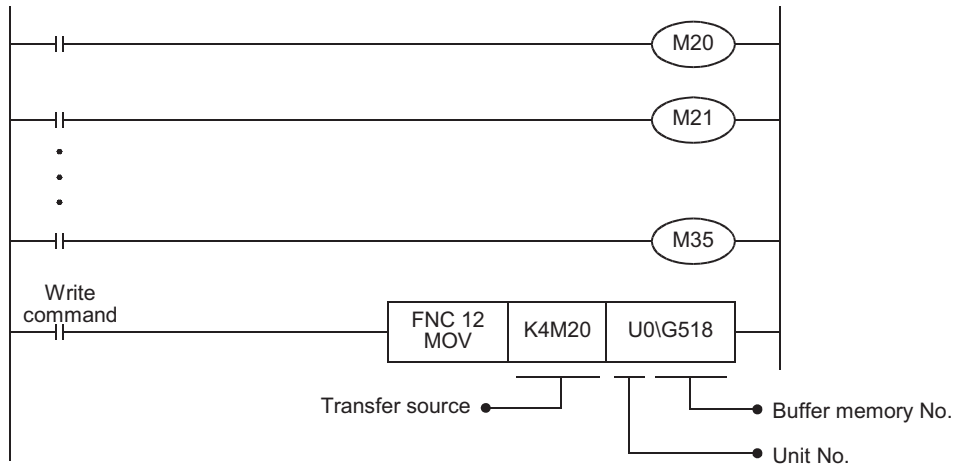

- d) Writing the bit information stored in data registers to the buffer memory
In the program below, the ON/OFF status of each bit of a data register (D201) is written to the buffer memory (BFM#518) in the unit No. 0. Each bit of the data register (D201) should be set to ON or OFF in advance by bit specification of word devices.

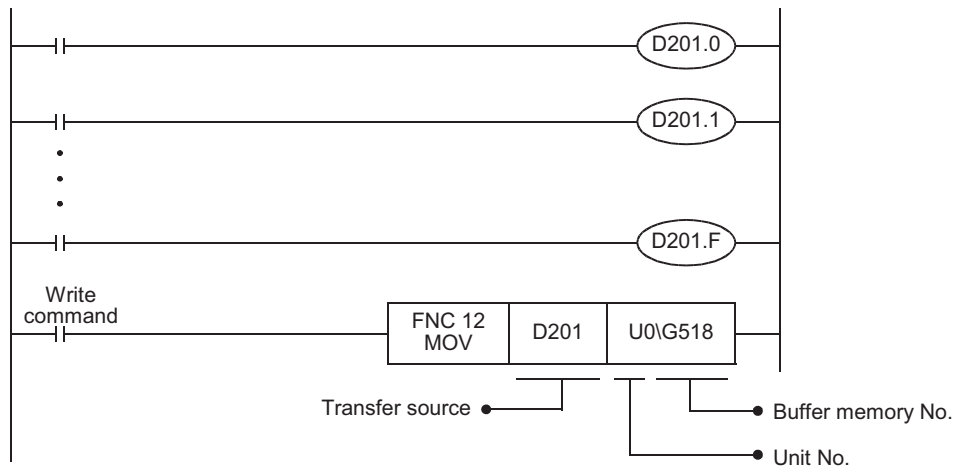

2) FROM/TO instructions (conventional method)

Read the contents of the buffer memory using the FROM/TO instructions.

- a) Reading and transferring the bit information to auxiliary relays

In the program below, the contents of the buffer memory (BFM#0) in the unit No. 1 are read and transferred to auxiliary relays (M40 to M55).

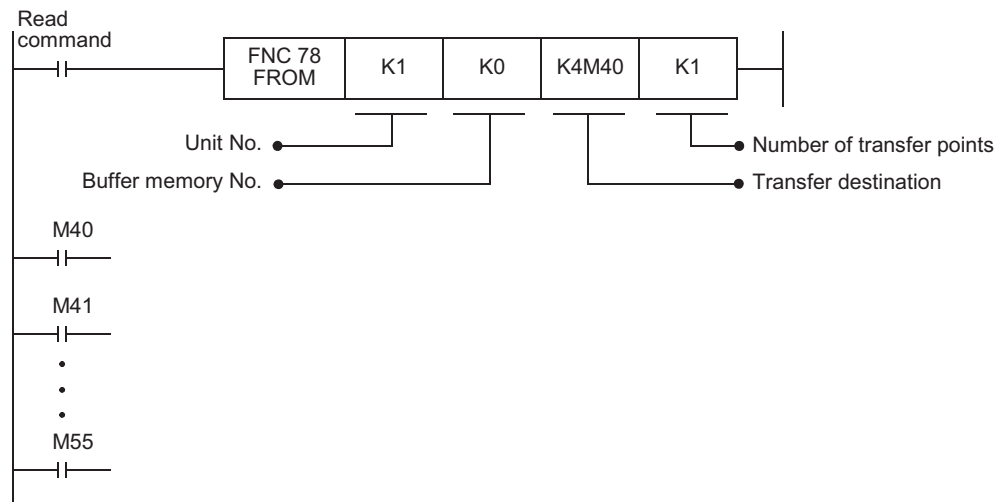

b) Reading and transferring the bit information to data registers

In the program below, the contents of the buffer memory (BFM#0) in the unit No. 1 are read and transferred to a data register (D200). The read bit information is used in bit specification of word devices.

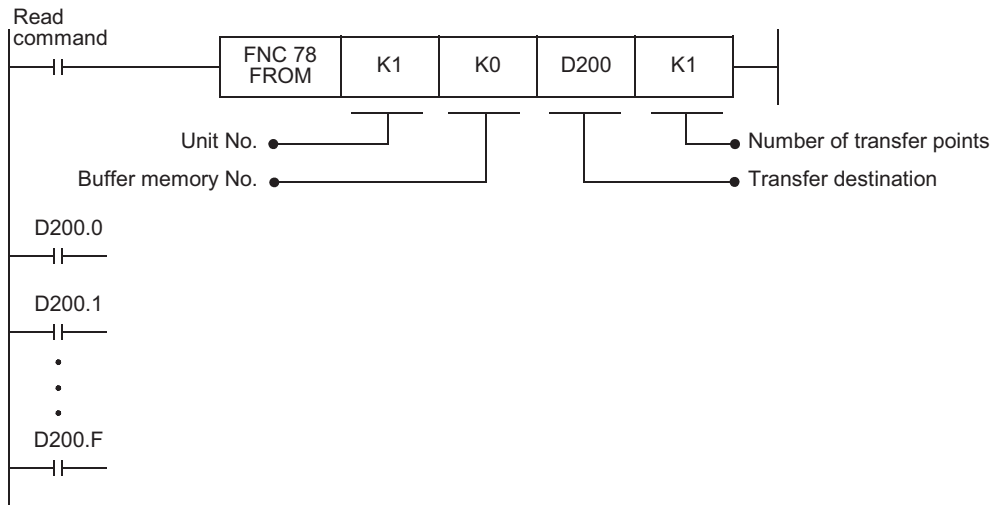

c) Writing the bit information of auxiliary relays to the buffer memory

In the program below, the ON/OFF status of auxiliary relays (M20 to M35) is written to the buffer memory (BFM#518) in the unit No. 0.

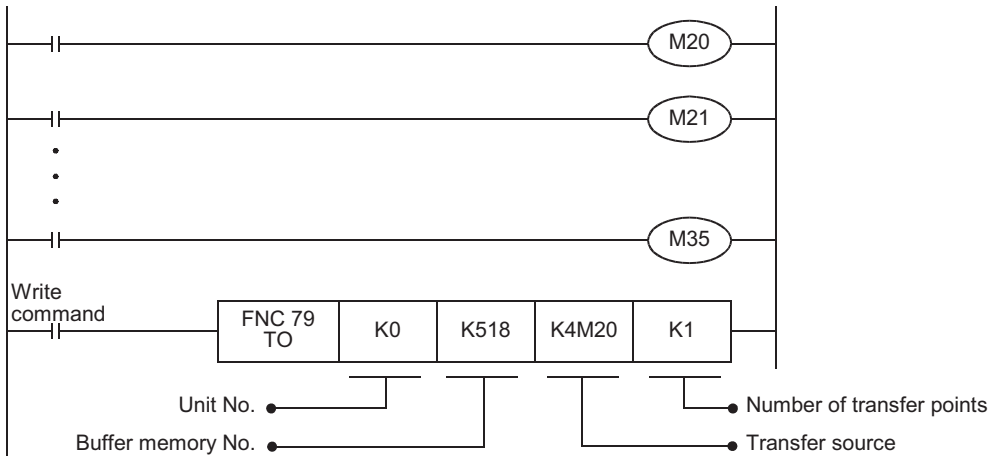

d) Writing the bit information stored in data registers to the buffer memory

In the program below, the ON/OFF status of each bit of a data register (D201) is written to the buffer memory (BFM#518) in the unit No. 0. Each bit of the data register (D201) should be set to ON or OFF in advance by bit specification of word devices.

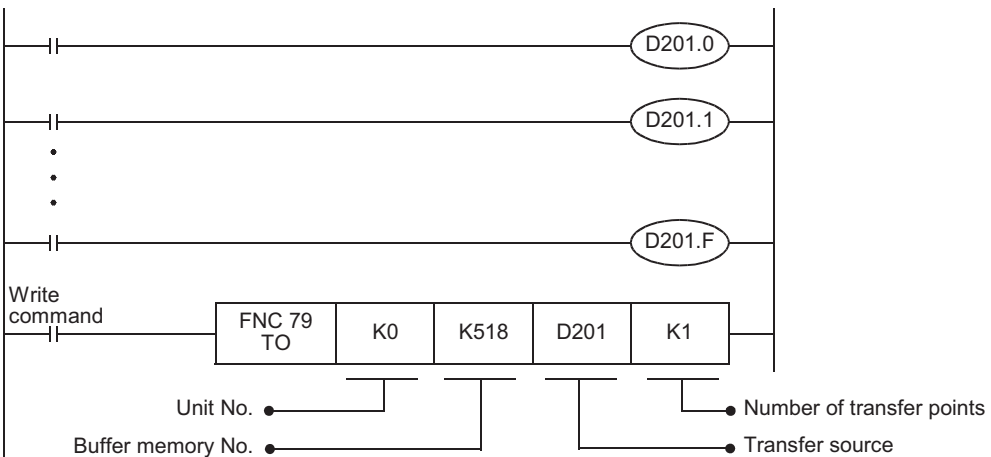

9.2 Example of a Program for PID Control

This section provides an example of a program for PID control.

9.2.1 System configuration

The system configuration shown below explains the example program.

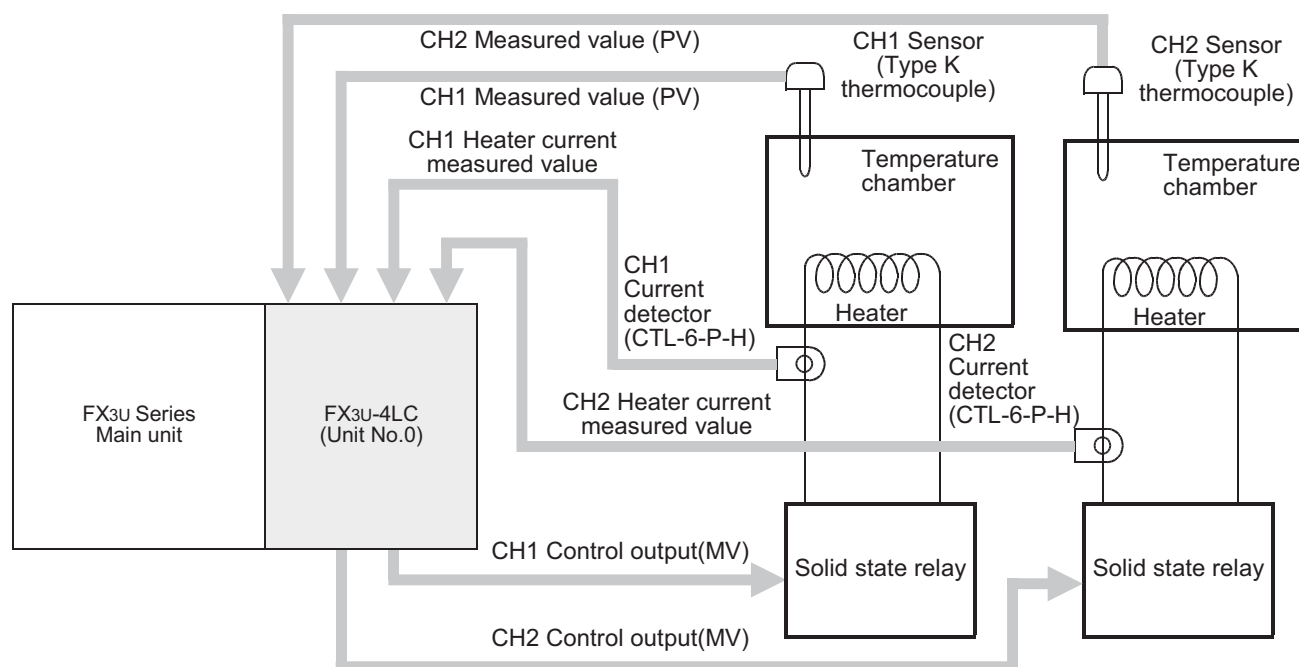

9.2.2 Conditions of operation

The example program is set up with the following operation conditions.

Initial values are used for conditions of operation other than the ones listed below. They are not shown in this example.

Please modify the example program as needed.

Item	BFM No.		Conditions of operation
	CH1	CH2	
Alarm 1 set value	#49	#89	Upper limit deviation is set to "30.0°C"
Alarm 2 set value	#50	#90	Lower limit deviation is set to "-30.0°C"
Operation mode	#57	#97	Set "3 : Monitor + Alarm + Control" (initial value)
PID value	Proportional band (P)	#58	Set by auto tuning
	Integral time (I)	#60	
	Derivative time (D)	#61	
Control response parameter	#62	#102	Set "1 : Medium"
Normal/reverse operation selection	#75	#115	Set "1 : Reverse operation" (initial value)
Transistor output selection	#86	#126	Set "0" (initial value)
Input type	#208	#214	Set "1 : K type -100.0 to 400.0°C"
Alarm 1 mode setting	#209	#215	Set "12 : Upper limit deviation alarm with re-wait"
Alarm 2 mode setting	#210	#216	Set "13 : Lower limit deviation alarm with re-wait"
Temperature rise completion range setting	#236		Set "3°C"
CT monitor method switch	#238		Set "0 : ON current/OFF current" (initial value)
CT ratio setting	#239		Set "800" (initial value) When a current detector (CTL-6-P-H) is used.
Control mode switch	#240		Set "0" (initial value)

9.2.3 Device assignments

Device assignments of the example program are assigned as follows.

Device No.	Contents of operation
X000	When X000 is turned on, parameters are initialized in the buffer memory.
X001	Initializes all data.
X002	Error reset is performed.
X003	PID control is started.
X004	Performs auto tuning (CH1).
X005	Performs auto tuning (CH2).
M0 to M15	The state of a flag is read. The example program has included operation to carry out external output of the state of the error present (b0).
M20 to M35	The state of an event (CH1) is read. The example program has included operation to carry out external output of the state of the loop disconnection alarm (b8) of CH1.
M40 to M55	The state of an event (CH2) is read. The example program has included operation to carry out external output of the state of the loop disconnection alarm (b8) of CH2.
D0	Setting value (CH1) is stored.
D1	Setting value (CH2) is stored.
D5	Measured value (CH1) is stored.
D6	Measured value (CH2) is stored.
D9	Control output value (CH1) is stored.
D10	Control output value (CH2) is stored.
D21	Heater current measured value (CH1) is stored.
D22	Heater current measured value (CH2) is stored.
D252	The value of a set value range error address is stored.

9.2.4 Sequence program

The sequence program for the example program with the FX3U-4LC as unit No. 0 is shown below. Change unit No.0 to match the actual system configuration to be used.

The FROM/TO instructions are used for read/write of buffer memory.

- For details on the unit No., refer to Subsection 9.1.1.
- For details on the how to read/write from/to buffer memory, refer to Subsection 9.1.2.
- For details on the system configuration, refer to Subsection 9.2.1.
- For details on the conditions of operation, refer to Subsection 9.2.2.
- For details on the device assignments, refer to Subsection 9.2.3.

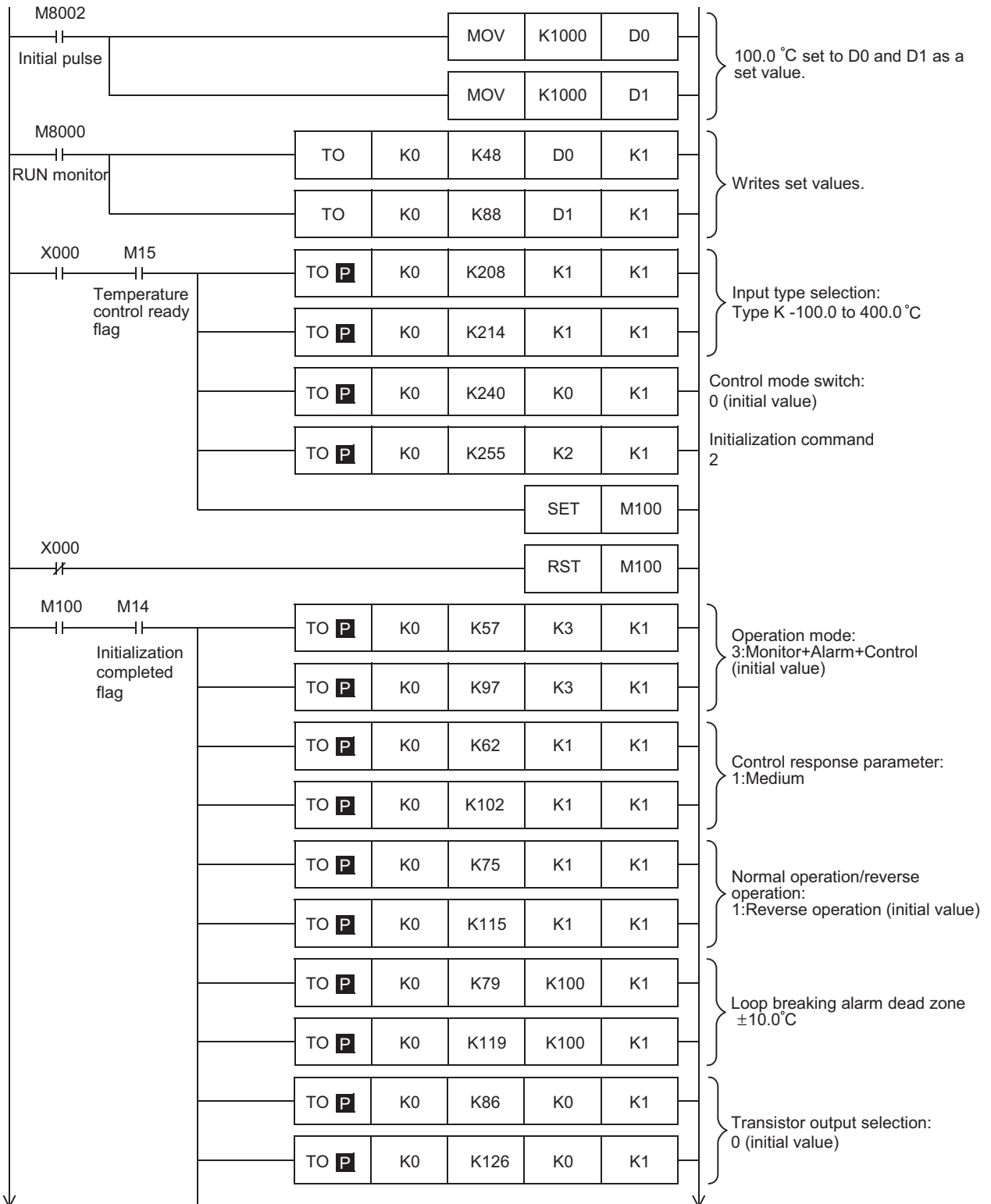

To next page

To next page

- 1 Introduction
- 2 Specification
- 3 System Configuration
- 4 Installation
- 5 Wiring
- 6 Introduction of Functions
- 7 Alarm
- 8 Buffer Memory
- 9 Program Examples
- 10 Troubleshooting

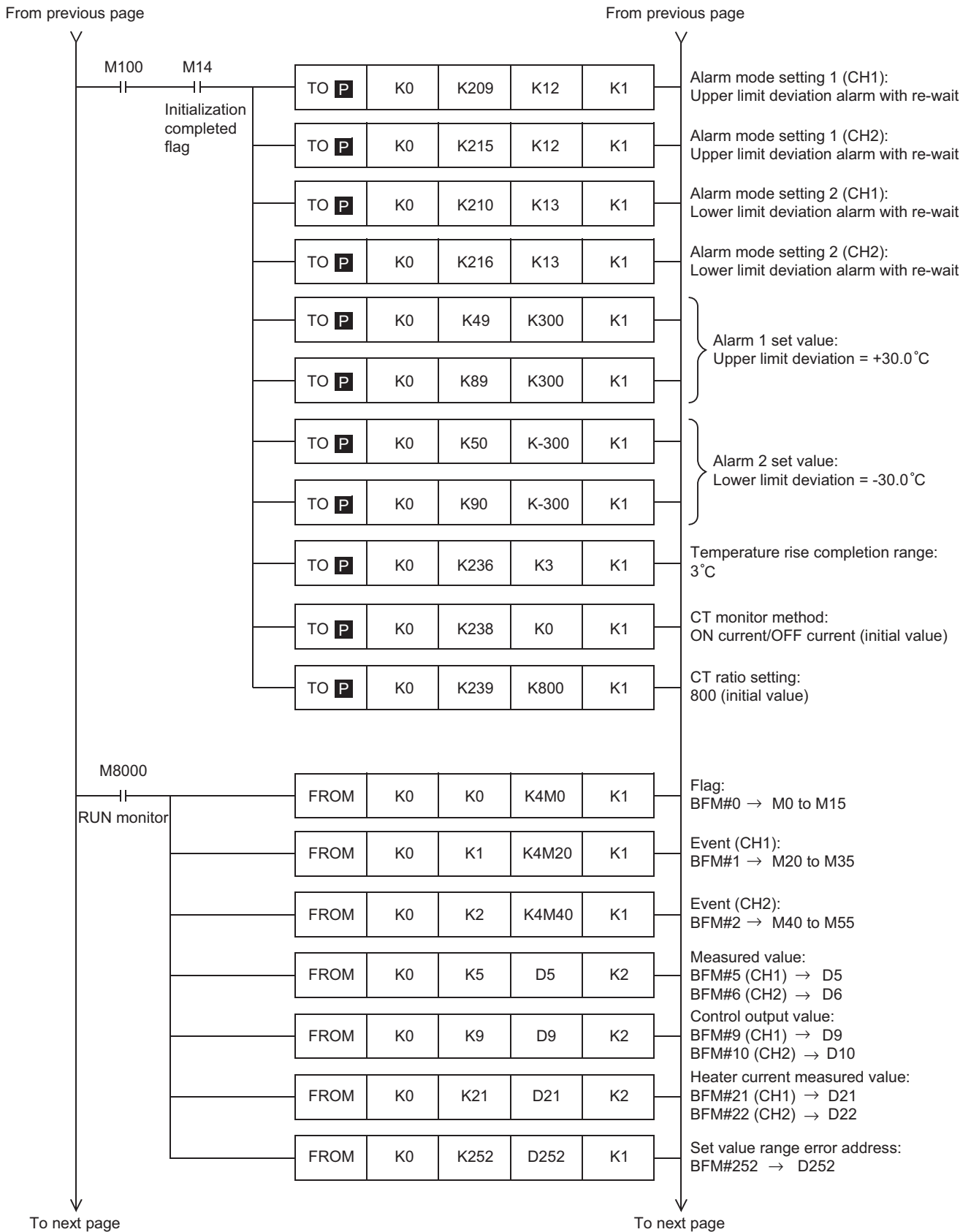

From previous page

From previous page

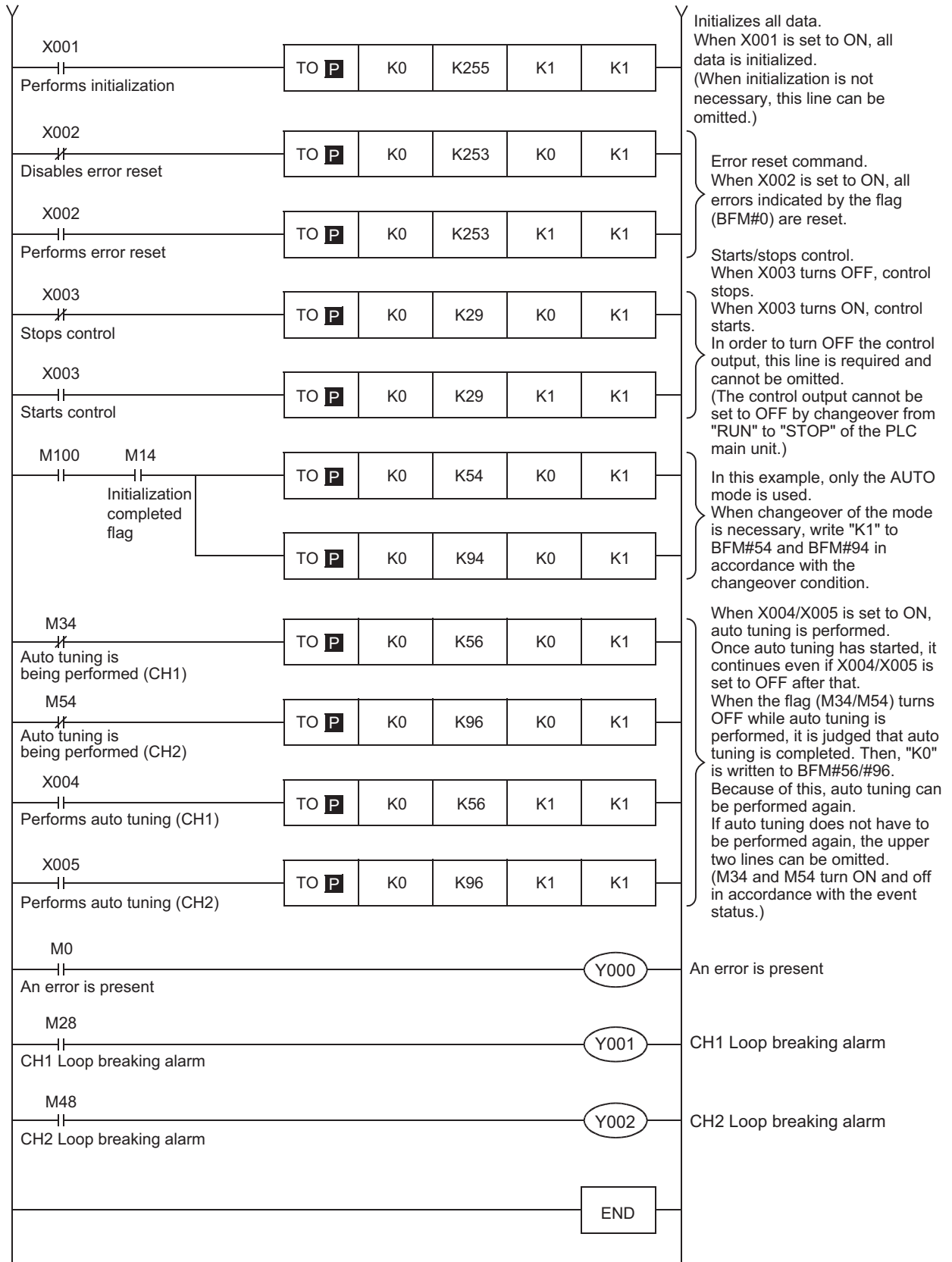

1	Introduction
2	Specification
3	System Configuration
4	Installation
5	Wiring
6	Introduction of Functions
7	Alarm
8	Buffer Memory
9	Program Examples
10	Troubleshooting

9.3 Example of a Program for Heating/Cooling PID Control

This section provides an example of a program for heating/cooling PID control.

9.3.1 System configuration

The system configuration shown below explains the example program.

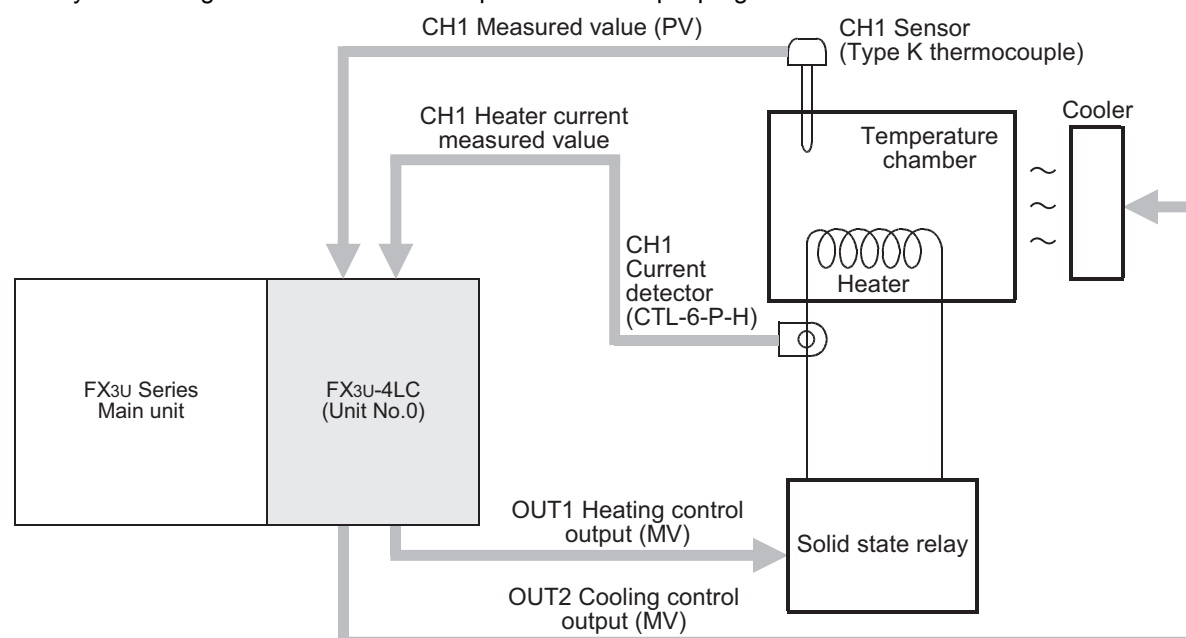

9.3.2 Conditions of operation

The example program set up with the following operation conditions.

Initial values are used for conditions of operation other than the ones listed below. They are not shown in this example.

Please add to the example of a program if needed.

Item	BFM No.		Conditions of operation
	CH1	CH2	
Alarm 1 set value	#49	-	Upper limit deviation is set to "30.0°C"
Alarm 2 set value	#50	-	Lower limit deviation is set to "-30.0°C"
Operation mode	#57	-	Set "3 : Monitor + Alarm + Control" (initial value)
PID value	Heating proportional band (P)	#58	-
	Cooling proportional band (P)	#59	-
	Integral time (I)	#60	-
	Derivative time (D)	#61	-
Control response parameter	#62	-	Set "1 : Medium"
Overlap/Dead band	#63	-	Set "0" (initial value)
Transistor output selection	#86	-	Set "0" (initial value)
Input range	#208	-	Set "1 : K type -100.0 to 400.0°C"
Alarm 1 mode setting	#209	-	Set "12 : Upper limit deviation alarm with re-wait"
Alarm 2 mode setting	#210	-	Set "13 : Lower limit deviation alarm with re-wait"
Cooling method setting	#232		Set "0 : Air cooling"
Temperature rise completion range setting	#236		Set "3°C"
CT monitor method switch	#238		Set "0 : ON current/OFF current" (initial value)
CT ratio setting	#239		Set "800" (initial value) When a current detector (CTL-6-P-H) is used.
Control mode switch	#240		Set "4"

9.3.3 Device assignments

Device assignments of the example program are assigned as follows.

Device No.	Contents of operation
X000	When X000 is turned on, parameters are initialized in the buffer memory.
X001	Initializes all data.
X002	Error reset is performed.
X003	Heating/Cooling PID Control is started.
X004	Performs auto tuning (CH1).
M0 to M15	The state of a flag is read. The example program includes operation to carry out external output of the state of the error present (b0).
M20 to M35	The state of an event (CH1) is read. The example program includes operation to carry out external output of the state of the loop disconnection alarm (b8) of CH1.
D0	Setting value (CH1) is stored.
D5	Measured value (CH1) is stored.
D9	OUT1 Heating control output value is stored.
D14	OUT2 Cooling control output value is stored.
D21	Heater current measured value (CH1) is stored.
D252	The value of a set value range error address is stored.

1

Introduction

2

Specification

3

System
Configuration

4

Installation

5

Wiring

6

Introduction of
Functions

7

Alarm

8

Buffer Memory

9

Program
Examples

10

Troubleshooting

9.3.4 Sequence program

The sequence program for the example program with the FX3U-4LC as unit No. 0 is shown below. Change unit No.0 to match the actual system configuration to be used.

The FROM/TO instructions are used for read/write of buffer memory.

- For details on the unit No., refer to Subsection 9.1.1.
- For details on the how to read/write from/to buffer memory, refer to Subsection 9.1.2.
- For details on the system configuration, refer to Subsection 9.3.1.
- For details on the conditions of operation, refer to Subsection 9.3.2.
- For details on the device assignments, refer to Subsection 9.3.3.

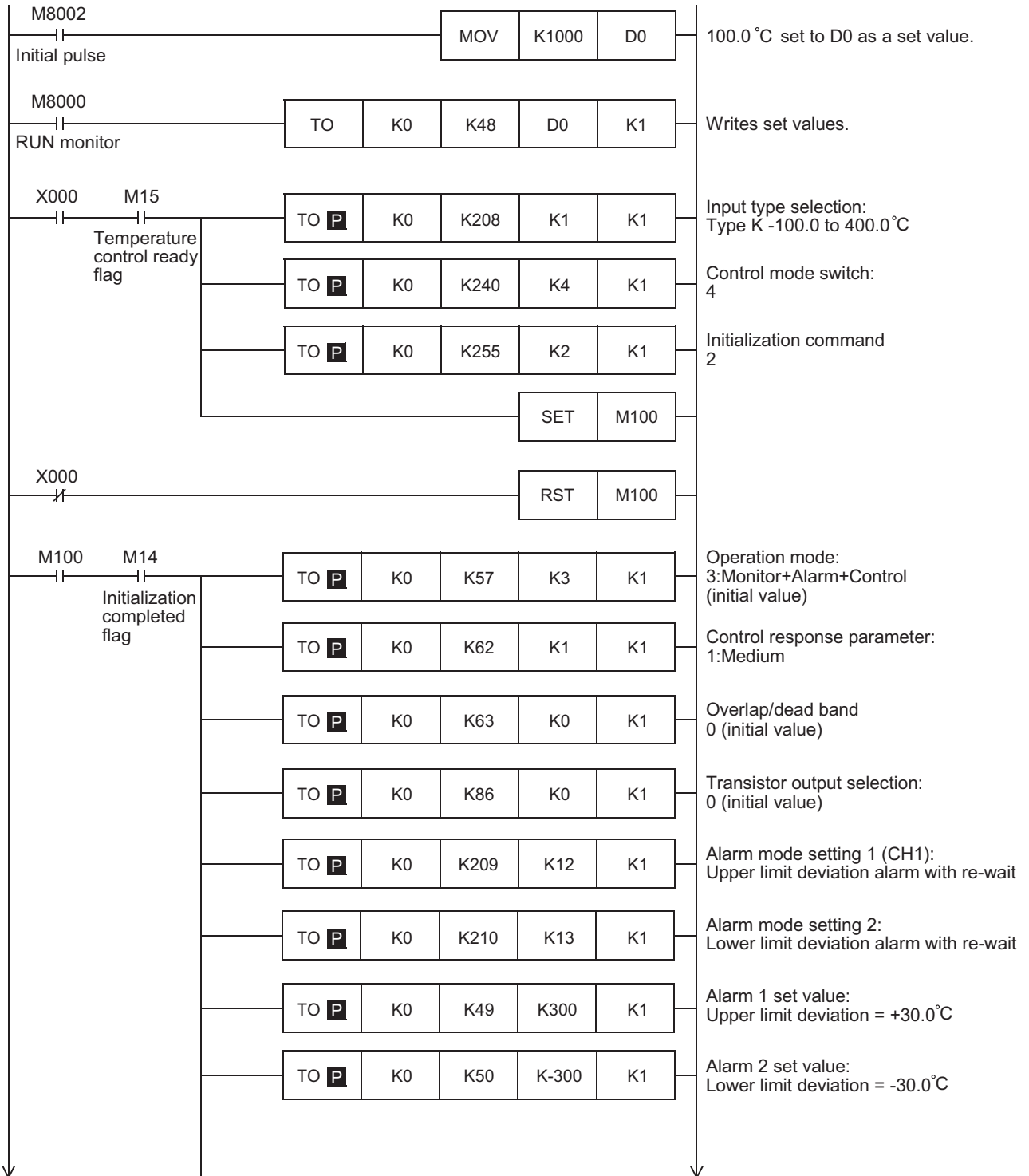

To next page

To next page

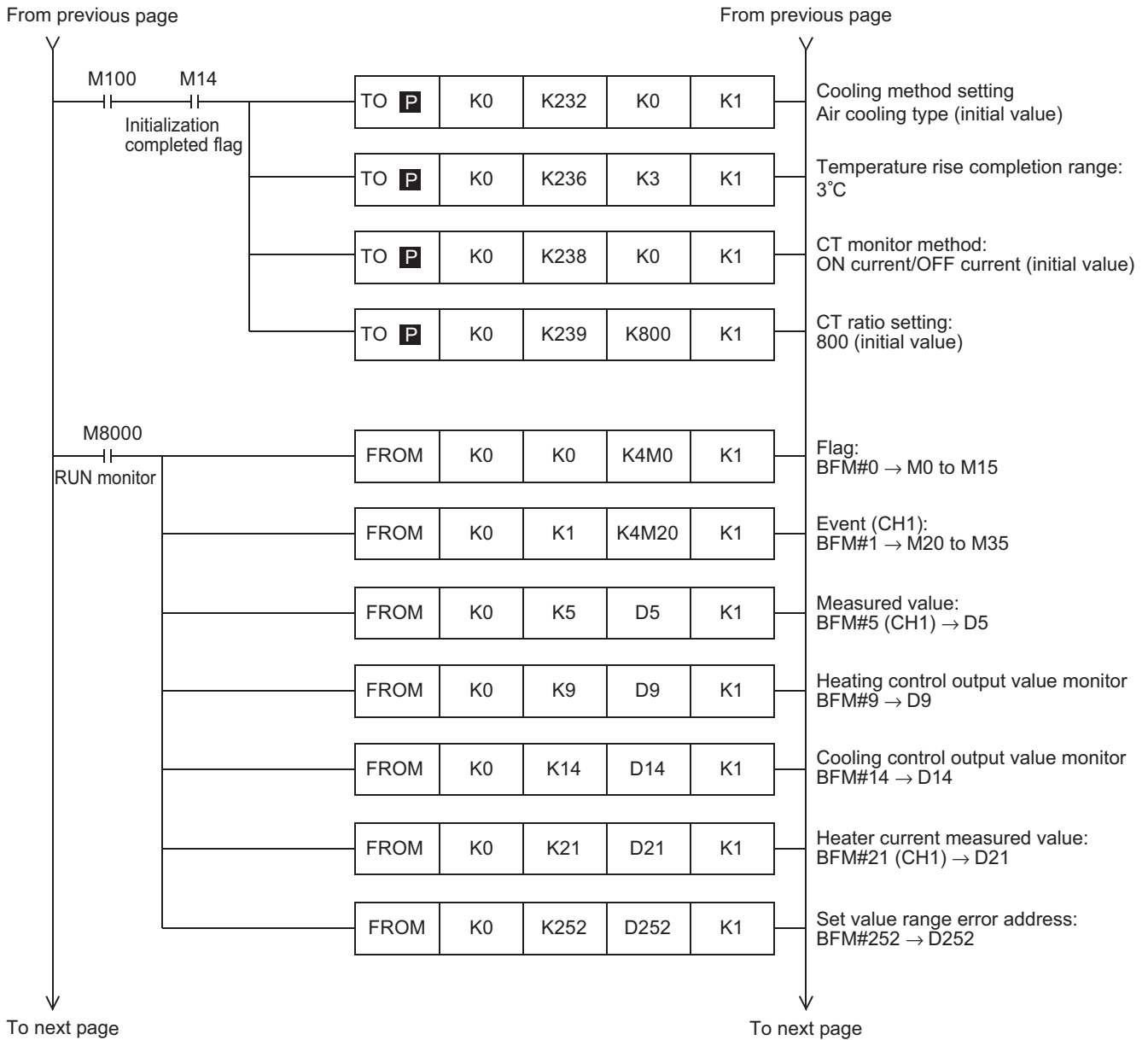

1	Introduction
2	Specification
3	System Configuration
4	Installation
5	Wiring
6	Introduction of Functions
7	Alarm
8	Buffer Memory
9	Program Examples
10	Troubleshooting

From previous page

From previous page

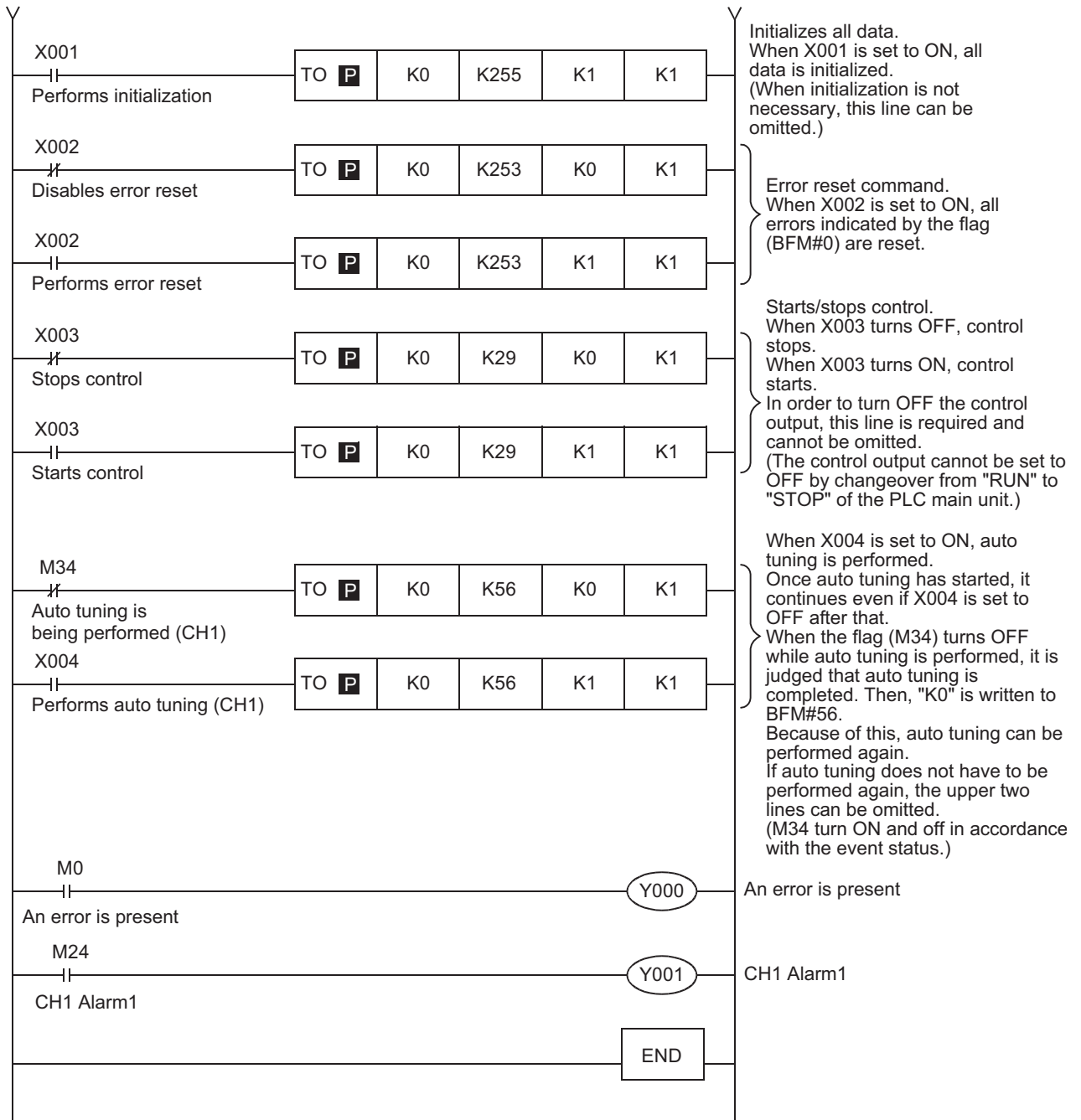

10. Troubleshooting

When a fault occurs, check the power supply voltage, the PLC main unit and the 4LC for loose terminal screws, and examine the connectors for a defective contact.

STARTUP AND MAINTENANCE PRECAUTIONS



DANGER

- Make sure to connect the battery correctly. Do not charge, disassemble, heat, short-circuit, or expose the battery to fire. Doing so may rupture or ignite it.
- Do not touch any terminal while the PLC's power is on. Doing so may cause electric shock or malfunctions.
- Before modifying or disrupting the program in operation or running the PLC, carefully read through this manual and the associated manuals and ensure the safety of the operation. An operation error may damage the machinery or cause accidents.

STARTUP AND MAINTENANCE PRECAUTIONS



CAUTION

- Do not disassemble or modify the PLC. Doing so may cause fire, equipment failures, or malfunctions. For repair, contact your local Mitsubishi Electric distributor.
- Turn off the power to the PLC before attaching or detaching the following devices. Failure to do so may cause device failures or malfunctions.
 - Peripheral devices, display modules, expansion boards and special adapters
 - I/O extension units/blocks, FX Series terminal block and the special function units/blocks
 - Battery and memory cassette

1

Introduction

2

Specification

3

System
Configuration

4

Installation

5

Wiring

6

Introduction of
Functions

7

Alarm

8

Buffer Memory

9

Program
Examples

10

Troubleshooting

10.1 Troubleshooting Procedure

The flag (BFM#0) and event (BFM#1 to BFM#4) buffer memories store errors detected in the 4LC. You can check the contents of errors by monitoring the buffer memories using peripheral equipment or reading the contents of the buffer memories using the FROM instruction (or direct specification of buffer memories).

Flag (BFM#0)

The following bits of the flag buffer memory (BFM#0) indicate errors.

Bit	Description	Cause of error
b0	Error present	Turns ON when an error among b1 to b10 below has occurred.
b1	Set value range error	Turns ON when data outside set range is written. The buffer memory number in which an error has been generated is stored in a set value range error address (BFM#252).
b2	24V DC power supply error	Turns ON when driving power supply (24V DC) is not supplied.
b3	Set value backup error flag	Turns ON when an error has been caused by noise or when a failure has occurred in the 4LC. Turn the power ON again, and check for changes in the state. If no improvement is obtained, consult a Mitsubishi Electric distributor.
b4	CH1 AT/ST abnormal end flag	Turns ON when CH1 AT (auto tuning) or ST (startup tuning) abnormally ends.
b5	CH2 AT/ST abnormal end flag	Turns ON when CH2 AT (auto tuning) or ST (startup tuning) abnormally ends.
b6	CH3 AT/ST abnormal end flag	Turns ON when CH3 AT (auto tuning) or ST (startup tuning) abnormally ends.
b7	CH4 AT/ST abnormal end flag	Turns ON when CH4 AT (auto tuning) or ST (startup tuning) abnormally ends.
b8	Adjustment data error	Turns ON when an error has been caused by noise or when a failure has occurred in the 4LC. Turn the power ON again, and check for changes in the state. If no improvement is obtained, consult a Mitsubishi Electric distributor.
b9	Cold contact temperature compensation data error	
b10	A/D converted value error	

Event (BFM#1)

The following bits of the event buffer memory (BFM#1) indicate errors.

Bit	Description	Cause of error
b0	Input error (upper limit)	Turns ON when input value is over scale.
b1	Input error (lower limit)	Turns ON when input value is under scale.
b2	Cold contact temperature compensation data error	Turns ON when an error has been caused by noise or when a failure has occurred in the 4LC. Turn the power ON again, and check for changes in the state. If no improvement is obtained, consult a Mitsubishi Electric distributor.
b3	A/D converted value error	
b4	Alarm 1	Turns ON when an alarm 1 has occurred.
b5	Alarm 2	Turns ON when an alarm 2 has occurred.
b6	Alarm 3	Turns ON when an alarm 3 has occurred.
b7	Alarm 4	Turns ON when an alarm 4 has occurred.
b8	Loop breaking alarm	Turns ON when a loop breaking alarm has occurred
b9	Heater disconnection alarm	Turns ON when a heater disconnection alarm has occurred.
b10	Current error when output is OFF	Turns ON when a current error occurs while output is OFF.

10.1.1 How to reset an error

After removing the cause of the error, reset the error by executing the error reset command. If the cause of the error remains, the error bit turns ON again. For details of the error reset command, refer to the following.

→ Refer to Subsection 8.2.69.

10.2 Diagnostics on the PLC Main Unit

The following describes some of the PLC errors from the LED lights on the PLC.

For details related to the PLC main unit wiring, special auxiliary relays, and special data registers, refer to the following respective manuals.

- Refer to the FX3G Hardware Edition.
- Refer to the FX3U Hardware Edition.
- Refer to the FX3UC Hardware Edition.

10.2.1 POWER (POW) LED [on/flashing/off]

The table below describes details for the LED statuses.

Status	PLC Status	Error corrective action
ON	Power of the specified voltage is being supplied to the power supply terminal.	The power supply is normal.
Flicker	One of the following causes may have occurred. <ul style="list-style-type: none"> • Power and current of the specified voltage is not being supplied to the power supply terminal. • Incorrect external wiring. • Internal errors in the PLC. 	<ul style="list-style-type: none"> • Check the supply voltage. • After disconnecting cables other than the power cable, turn the power ON again, and check for changes in the state. If no improvement is obtained, consult a Mitsubishi Electric distributor.
OFF	One of the following causes may have occurred. <ul style="list-style-type: none"> • The power supply is OFF. • Incorrect external wiring. • Power of the specified voltage is not being supplied to the power supply terminal. • The power cable is broken. 	<ul style="list-style-type: none"> • If the power is not OFF, check the power supply and the power supply route. If power is being supplied correctly, consult a Mitsubishi Electric distributor. • After disconnecting cables other than the power cable, turn the power ON again, and check for changes in the state. If no improvement is obtained, consult a Mitsubishi Electric distributor.

10.2.2 BATT (BAT) LED [on/off]

The table below describes details for the LED statuses.

Status	PLC Status	Error corrective action
ON	The battery voltage is low.	Immediately replace the battery.
OFF	The battery voltage is higher than the value with D8006.	Normal

1

Introduction

2

Specification

3

System Configuration

4

Installation

5

Wiring

6

Introduction of Functions

7

Alarm

8

Buffer Memory

9

Program Examples

10

Troubleshooting

10.2.3 ERROR (ERR) LED [on/flashing/off]

The table below describes details for the LED statuses.

Status	PLC Status	Error corrective action
ON	A watchdog timer error may have occurred, or the hardware of the PLC may be damaged.	<ol style="list-style-type: none"> 1) Stop the PLC, and turn the power ON again. If the ERROR (ERR) LED goes out, a watchdog timer error may have occurred. Adopt any of the following measures: <ul style="list-style-type: none"> - Review the program. Set the maximum value (D8012) lower than the watchdog timer value. - Check that the input used for input interrupt or pulse catch is not being abnormally turned ON and OFF in one scan. - Check that the frequency of the pulse (duty 50%) input to the high-speed counter is not exceeding the specified range. - Add WDT instructions. Add some WDT instructions to the program, and reset the watchdog timer several times in one scan. - Change the watchdog timer value. Change the watchdog timer setting (D8000) in the program so that the setting is larger than the maximum value of the scan time (D8012). 2) Remove the PLC and supply the power to it from another power source. If the ERROR (ERR) LED goes out, noise may have affected the PLC. Adopt the following measures: <ul style="list-style-type: none"> - Check the ground wiring, and re-examine the wiring route and installation location. - Fit a noise filter onto the power supply line. 3) If the ERROR (ERR) LED does not go out even after measures in 1) and 2) are adopted, consult a Mitsubishi Electric distributor.
Flicker	One of the following errors has occurred on the PLC: <ul style="list-style-type: none"> • Parameter error • Syntax error • Ladder error 	Perform PLC diagnosis and program check with the programming tool.
OFF	No errors to stop the PLC have occurred.	If the operations of the PLC are abnormal, perform PLC diagnosis and program check with the programming tool. An I/O error, parallel link/communication error, or operation error may have occurred.

Appendix A: Version Information

Appendix A-1 Version Information

Appendix A-1-1 Version check method

The 4LC version is shown as "S/N" on the label attached to the right side of the module as seen from the front.

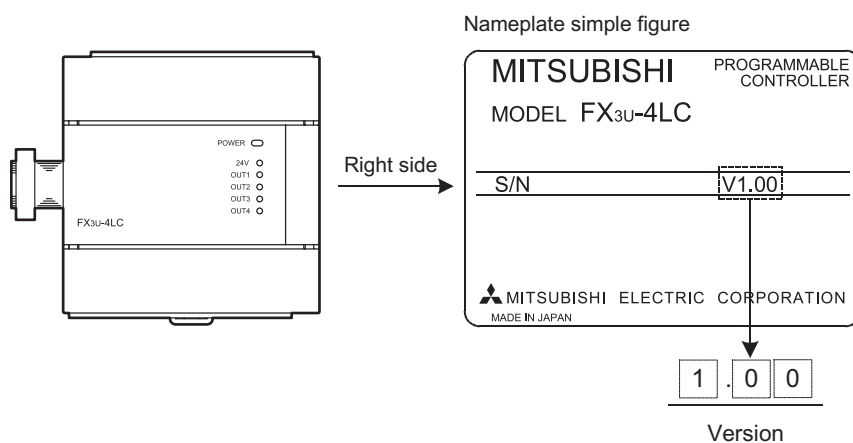

Appendix A-1-2 Version upgrade history

The table below shows the version upgrade history for the 4LC.

Version	Contents of version upgrade
Ver.1.00	First product

MEMO

Warranty

Please confirm the following product warranty details before using this product.

1. Gratis Warranty Term and Gratis Warranty Range

If any faults or defects (hereinafter "Failure") found to be the responsibility of Mitsubishi occurs during use of the product within the gratis warranty term, the product shall be repaired at no cost via the sales representative or Mitsubishi Service Company. However, if repairs are required onsite at domestic or overseas location, expenses to send an engineer will be solely at the customer's discretion. Mitsubishi shall not be held responsible for any re-commissioning, maintenance, or testing on-site that involves replacement of the failed module.

[Gratis Warranty Term]

The gratis warranty term of the product shall be for one year after the date of purchase or delivery to a designated place. Note that after manufacture and shipment from Mitsubishi, the maximum distribution period shall be six (6) months, and the longest gratis warranty term after manufacturing shall be eighteen (18) months. The gratis warranty term of repair parts shall not exceed the gratis warranty term before repairs.

[Gratis Warranty Range]

- 1) The range shall be limited to normal use within the usage state, usage methods and usage environment, etc., which follow the conditions and precautions, etc., given in the instruction manual, user's manual and caution labels on the product.
- 2) Even within the gratis warranty term, repairs shall be charged for in the following cases.
 - a) Failure occurring from inappropriate storage or handling, carelessness or negligence by the user. Failure caused by the user's hardware or software design.
 - b) Failure caused by unapproved modifications, etc., to the product by the user.
 - c) When the Mitsubishi product is assembled into a user's device, Failure that could have been avoided if functions or structures, judged as necessary in the legal safety measures the user's device is subject to or as necessary by industry standards, had been provided.
 - d) Failure that could have been avoided if consumable parts (battery, backlight, fuse, etc.) designated in the instruction manual had been correctly serviced or replaced.
 - e) Relay failure or output contact failure caused by usage beyond the specified Life of contact (cycles).
 - f) Failure caused by external irresistible forces such as fires or abnormal voltages, and failure caused by force majeure such as earthquakes, lightning, wind and water damage.
 - g) Failure caused by reasons unpredictable by scientific technology standards at time of shipment from Mitsubishi.
 - h) Any other failure found not to be the responsibility of Mitsubishi or that admitted not to be so by the user.

2. Onerous repair term after discontinuation of production

- 1) Mitsubishi shall accept onerous product repairs for seven (7) years after production of the product is discontinued. Discontinuation of production shall be notified with Mitsubishi Technical Bulletins, etc.
- 2) Product supply (including repair parts) is not available after production is discontinued.

3. Overseas service

Overseas, repairs shall be accepted by Mitsubishi's local overseas FA Center. Note that the repair conditions at each FA Center may differ.

4. Exclusion of loss in opportunity and secondary loss from warranty liability

Regardless of the gratis warranty term, Mitsubishi shall not be liable for compensation of damages caused by any cause found not to be the responsibility of Mitsubishi, loss in opportunity, lost profits incurred to the user or third person by Failures of Mitsubishi products, special damages and secondary damages whether foreseeable or not, compensation for accidents, and compensation for damages to products other than Mitsubishi products, replacement by the user, maintenance of on-site equipment, start-up test run and other tasks.

5. Changes in product specifications

The specifications given in the catalogs, manuals or technical documents are subject to change without prior notice.

6. Product application

- 1) In using the Mitsubishi MELSEC programmable logic controller, the usage conditions shall be that the application will not lead to a major accident even if any problem or fault should occur in the programmable logic controller device, and that backup and fail-safe functions are systematically provided outside of the device for any problem or fault.
- 2) The Mitsubishi programmable logic controller has been designed and manufactured for applications in general industries, etc. Thus, applications in which the public could be affected such as in nuclear power plants and other power plants operated by respective power companies, and applications in which a special quality assurance system is required, such as for Railway companies or Public service purposes shall be excluded from the programmable logic controller applications. In addition, applications in which human life or property that could be greatly affected, such as in aircraft, medical applications, incineration and fuel devices, manned transportation, equipment for recreation and amusement, and safety devices, shall also be excluded from the programmable logic controller range of applications. However, in certain cases, some applications may be possible, providing the user consults their local Mitsubishi representative outlining the special requirements of the project, and providing that all parties concerned agree to the special circumstances, solely at the users discretion.

Revised History

Date	Revision	Description
1/2010	A	First Edition
5/2010	B	Errors are corrected.

FX3U-4LC

USER'S MANUAL



HEAD OFFICE: TOKYO BUILDING, 2-7-3 MARUNOUCHI, CHYODA-KU, TOKYO 100-8310, JAPAN
HIMEJI WORKS: 840, CHIYODA CHO, HIMEJI, JAPAN

MODEL	FX3U-4LC-U-E
MODEL CODE	09R625

HEADQUARTERS

MITSUBISHI ELECTRIC EUROPE B.V. **EUROPE**
 German Branch
 Gothaer Straße 8
D-40880 Ratingen
 Phone: +49 (0)2102 / 486-0
 Fax: +49 (0)2102 / 486-1120

MITSUBISHI ELECTRIC EUROPE B.V. **CZECH REPUBLIC**
 Czech Branch
 Avenir Business Park, Radlická 714/113a
CZ-158 00 Praha 5
 Phone: +420 - 251 551 470
 Fax: +420 - 251-551-471

MITSUBISHI ELECTRIC EUROPE B.V. **FRANCE**
 French Branch
 25, Boulevard des Bouvets
F-92741 Nanterre Cedex
 Phone: +33 (0)1 / 55 68 55 68
 Fax: +33 (0)1 / 55 68 57 57

MITSUBISHI ELECTRIC EUROPE B.V. **IRELAND**
 Irish Branch
 Westgate Business Park, Ballymount
IRL-Dublin 24
 Phone: +353 (0)1 4198800
 Fax: +353 (0)1 4198890

MITSUBISHI ELECTRIC EUROPE B.V. **ITALY**
 Italian Branch
 Viale Colleoni 7
I-20041 Agrate Brianza (MB)
 Phone: +39 039 / 60 53 1
 Fax: +39 039 / 60 53 312

MITSUBISHI ELECTRIC EUROPE B.V. **POLAND**
 Poland Branch
 Krakowska 50
PL-32-083 Balice
 Phone: +48 (0)12 / 630 47 00
 Fax: +48 (0)12 / 630 47 01

MITSUBISHI ELECTRIC EUROPE B.V. **SPAIN**
 Spanish Branch
 Carretera de Rubí 76-80
E-08190 Sant Cugat del Vallés (Barcelona)
 Phone: 902 131121 // +34 935653131
 Fax: +34 935891579

MITSUBISHI ELECTRIC EUROPE B.V. **UK**
 UK Branch
 Travellers Lane
UK-Hatfield, Herts. AL10 8XB
 Phone: +44 (0)1707 / 27 61 00
 Fax: +44 (0)1707 / 27 86 95

MITSUBISHI ELECTRIC CORPORATION **JAPAN**
 Office Tower "Z" 14 F
 8-12, 1 chome, Harumi Chuo-Ku
Tokyo 104-6212
 Phone: +81 3 622 160 60
 Fax: +81 3 622 160 75

MITSUBISHI ELECTRIC AUTOMATION, Inc. **USA**
 500 Corporate Woods Parkway
Vernon Hills, IL 60061
 Phone: +1 847 478 21 00
 Fax: +1 847 478 22 53

EUROPEAN REPRESENTATIVES

GEVA **AUSTRIA**
 Wiener Straße 89
AT-2500 Baden
 Phone: +43 (0)2252 / 85 55 20
 Fax: +43 (0)2252 / 488 60

TEHNIKON **BELARUS**
 Oktyabrskaya 16/5, Off. 703-711
BY-220030 Minsk
 Phone: +375 (0)17 / 210 46 26
 Fax: +375 (0)17 / 210 46 26

ESCO DRIVES & AUTOMATION **BELGIUM**
 Culliganlaan 3
BE-1831 Diegem
 Phone: +32 (0)2 / 717 64 30
 Fax: +32 (0)2 / 717 64 31

Koning & Hartman b.v. **BELGIUM**
 Woluwelaan 31
BE-1800 Vilvoorde
 Phone: +32 (0)2 / 257 02 40
 Fax: +32 (0)2 / 257 02 49

INEA BH d.o.o. **BOSNIA AND HERZEGOVINA**
 Aleja Lipa 56
BA-71000 Sarajevo
 Phone: +387 (0)33 / 921 164
 Fax: +387 (0)33 / 524 539

AKHNATON **BULGARIA**
 4 Andrej Ljapchev Blvd. Pb 21
BG-1756 Sofia
 Phone: +359 (0)2 / 817 6004
 Fax: +359 (0)2 / 97 44 06 1

INEA CR d.o.o. **CROATIA**
 Losinjska 4 a
HR-10000 Zagreb
 Phone: +385 (0)1 / 36 940 -01 / -02 / -03
 Fax: +385 (0)1 / 36 940 -03

AutoCont C.S. s.r.o. **CZECH REPUBLIC**
 Technologická 374/6
CZ-708 00 Ostrava-Pustkovce
 Phone: +420 595 691 150
 Fax: +420 595 691 199

B:ELECTRIC, s.r.o. **CZECH REPUBLIC**
 Mladoboleslavská 812
CZ-197 00 Praha 19 - Kbely
 Phone: +420 286 850 848, +420 724 317 975
 Fax: +420 286 850 850

Beijer Electronics A/S **DENMARK**
 Lykkegårdsvej 17, 1.
DK-4000 Roskilde
 Phone: +45 (0)46 / 75 76 66
 Fax: +45 (0)46 / 75 56 26

Beijer Electronics Eesti OÜ **ESTONIA**
 Pärnu mnt.160i
EE-11317 Tallinn
 Phone: +372 (0)6 / 51 81 40
 Fax: +372 (0)6 / 51 81 49

Beijer Electronics OY **FINLAND**
 Jaakonkatu 2
FIN-01620 Vantaa
 Phone: +358 (0)207 / 463 500
 Fax: +358 (0)207 / 463 501

UTEKO A.B.E.E. **GREECE**
 5, Mavrogenous Str.
GR-18542 Piraeus
 Phone: +30 211 / 1206 900
 Fax: +30 211 / 1206 999

MELTRADE Ltd. **HUNGARY**
 Fertő utca 14.
HU-1107 Budapest
 Phone: +36 (0)1 / 431-9726
 Fax: +36 (0)1 / 431-9727

Beijer Electronics SIA **LATVIA**
 Vestienas iela 2
LV-1035 Riga
 Phone: +371 (0)784 / 2280
 Fax: +371 (0)784 / 2281

Beijer Electronics UAB **LITHUANIA**
 Savanorių Pr. 187
LT-02300 Vilnius
 Phone: +370 (0)5 / 232 3101
 Fax: +370 (0)5 / 232 2980

EUROPEAN REPRESENTATIVES

ALFATRADE Ltd. **MALTA**
 99, Paola Hill
Malta- Paola PLA 1702
 Phone: +356 (0)21 / 697 816
 Fax: +356 (0)21 / 697 817

INTEHSIS srl **MOLDOVA**
 bld. Traian 23/1
MD-2060 Kishinev
 Phone: +373 (0)22 / 66 4242
 Fax: +373 (0)22 / 66 4280

HIFLEX AUTOM.TECHNIEK B.V. **NETHERLANDS**
 Wolweverstraat 22
NL-2984 CD Ridderkerk
 Phone: +31 (0)180 - 46 60 04
 Fax: +31 (0)180 - 44 23 55

Koning & Hartman b.v. **NETHERLANDS**
 Haarlbergweg 21-23
NL-1101 CH Amsterdam
 Phone: +31 (0)20 / 587 76 00
 Fax: +31 (0)20 / 587 76 05

Beijer Electronics AS **NORWAY**
 Postboks 487
NO-3002 Drammen
 Phone: +47 (0)32 / 24 30 00
 Fax: +47 (0)32 / 84 85 77

Sirius Trading & Services srl **ROMANIA**
 Aleea Lacul Morii Nr. 3
RO-060841 Bucuresti, Sector 6
 Phone: +40 (0)21 / 430 40 06
 Fax: +40 (0)21 / 430 40 02

Craft Con. & Engineering d.o.o. **SERBIA**
 Bulevar Svetog Cara Konstantina 80-86
SER-18106 Nis
 Phone: +381 (0)18 / 292-24-4/5
 Fax: +381 (0)18 / 292-24-4/5

INEA SR d.o.o. **SERBIA**
 Izletnička 10
SER-113000 Smederevo
 Phone: +381 (0)26 / 617 163
 Fax: +381 (0)26 / 617 163

AutoCont Control s.r.o. **SLOVAKIA**
 Radlinského 47
SK-02601 Dolny Kubin
 Phone: +421 (0)43 / 5868210
 Fax: +421 (0)43 / 5868210

CS MTrade Slovensko, s.r.o. **SLOVAKIA**
 Vajanskeho 58
SK-92101 Piestany
 Phone: +421 (0)33 / 7742 760
 Fax: +421 (0)33 / 7735 144

INEA d.o.o. **SLOVENIA**
 Stegne 11
SI-1000 Ljubljana
 Phone: +386 (0)1 / 513 8100
 Fax: +386 (0)1 / 513 8170

Beijer Electronics AB **SWEDEN**
 Box 426
SE-20124 Malmö
 Phone: +46 (0)40 / 35 86 00
 Fax: +46 (0)40 / 35 86 02

Omni Ray AG **SWITZERLAND**
 Im Schörl 5
CH-8600 Dübendorf
 Phone: +41 (0)44 / 802 28 80
 Fax: +41 (0)44 / 802 28 28

GTS **TURKEY**
 Bayraktar Bulvari Nutuk Sok. No:5
TR-34775 Yukari Dudullu-Umraniye-ISTANBUL
 Phone: +90 (0)216 526 39 90
 Fax: +90 (0)216 526 3995

CSC Automation Ltd. **UKRAINE**
 4-B, M. Raskovoyi St.
UA-02660 Kiev
 Phone: +380 (0)44 / 494 33 55
 Fax: +380 (0)44 / 494-33-66

EURASIAN REPRESENTATIVES

Kazpromautomatiks Ltd. **KAZAKHSTAN**
 Mustafina Str. 7/2
KAZ-470046 Karaganda
 Phone: +7 7212 / 50 11 50
 Fax: +7 7212 / 50 11 50

MIDDLE EAST REPRESENTATIVES

TEXEL ELECTRONICS Ltd. **ISRAEL**
 2 Ha'umanut, P.O.B. 6272
IL-42160 Netanya
 Phone: +972 (0)9 / 863 39 80
 Fax: +972 (0)9 / 885 24 30

CEG INTERNATIONAL **LEBANON**
 Cebaco Center/Block A Autostrade DORA
Lebanon - Beirut
 Phone: +961 (0)1 / 240 430
 Fax: +961 (0)1 / 240 438

AFRICAN REPRESENTATIVE

CBI Ltd. **SOUTH AFRICA**
 Private Bag 2016
ZA-1600 Isando
 Phone: +27 (0)11 / 977 0770
 Fax: +27 (0)11 / 977 0761