

JY997D29201A

MITSUBISHI *Changes for the Better*
PROGRAMMABLE CONTROLLERS
MELSEC-F

FX3U-4AD-PNK-ADP

USER'S MANUAL

Manual Number	JY997D29201
Revision	A
Date	December 2007

This manual describes the part names, dimensions, mounting, and specifications of the product. Before use, read this manual and the manuals of all relevant products fully to acquire proficiency in handling and operating the product. Make sure to learn all the product information, safety information, and precautions. Store this manual in a safe place so that it can be taken out and read whenever necessary. Always forward it to the end user.
Registration:
The company and product names described in this manual are registered trademarks or the trademarks of their respective companies.
Effective December 2007
Specifications are subject to change without notice.
© 2007 Mitsubishi Electric Corporation

Safety Precaution (Read these precautions before use.)

This manual classifies the safety precautions into two categories:

⚠ DANGER and **⚠ CAUTION**.

⚠ DANGER	Indicates that incorrect handling may cause hazardous conditions, resulting in death or severe injury.
⚠ CAUTION	Indicates that incorrect handling may cause hazardous conditions, resulting in medium or slight personal injury or physical damage.

Depending on the circumstances, procedures indicated by **⚠ CAUTION** may also cause severe injury. It is important to follow all precautions for personal safety.

Associated Manuals

Manual name	Manual No.	Description
FX3U / FX3UC Series User's Manual - Analog Control Edition	JY997D16701 MODEL CODE: 09R619	Describes specifications for analog control and programming method for FX3U / FX3UC Series PLC.
FX3U/FX3UC Series Programming Manual - Basic & Applied Instruction Edition	JY997D16601 MODEL CODE: 09R517	Describes PLC programming for basic/applied instructions and devices.
FX3U Series User's Manual - Hardware Edition	JY997D16501 MODEL CODE: 09R516	Explains FX3U Series PLC specifications for I/O, wiring, installation, and maintenance.
FX3UC Series User's Manual - Hardware Edition	JY997D28701 MODEL CODE: 09R519	Explains FX3UC Series PLC specifications for I/O, wiring, installation, and maintenance.

How to obtain manuals

For product manuals or documents, consult with the Mitsubishi Electric dealer from who you purchased your product.

Certification of UL, cUL standards

The following product has UL and cUL certification.

UL, cUL File Number: E95239

Models: MELSEC FX3U series manufactured
FX3U-4AD-PNK-ADP

Compliance with EC directive (CE Marking)

This note does not guarantee that an entire mechanical module produced in accordance with the contents of this note will comply with the following standards. Compliance to EMC directive and LVD directive for the entire mechanical module should be checked by the user / manufacturer. For more details please contact the local Mitsubishi Electric sales site.

Requirement for Compliance with EMC directive

The following products have shown compliance through direct testing (of the identified standards below) and design analysis (through the creation of a technical construction file) to the European Directive for Electromagnetic Compatibility (89/336/EEC) when used as directed by the appropriate documentation.

Type: Programmable Controller (Open Type Equipment)
Models: MELSEC FX3U series manufactured
from December 1st, 2007 FX3U-4AD-PNK-ADP

Standard	Remark
EN61131-2:2003 Programmable controllers - Equipment requirements and tests	Compliance with all relevant aspects of the standard. EMI • Radiated Emissions • Mains Terminal Voltage Emissions EMS • RF immunity • Fast Transients • ESD • Surge • Conducted • Power magnetic fields

Caution for EC Directive

The FX3U-4AD-PNK-ADP have been found to be compliant to the European standards in the aforesaid manual and directive. However, for the very best performance from what are in fact delicate measuring and controlled output device Mitsubishi Electric would like to make the following points;

As analog devices are sensitive by nature, their use should be considered carefully. For users of proprietary cables (integral with sensors or actuators), these users should follow those manufacturers installation requirements. Mitsubishi Electric recommend that shielded cables should be used. If NO other EMC protection is provided, then users may experience temporary loss or accuracy between ±10% in very heavy industrial areas. However, Mitsubishi Electric suggest that if adequate EMC precautions are followed for the users complete control system, users should expect accuracy as specified in this manual.

- Sensitive analog cable should not be laid in the same trunking or cable conduit as high voltage cabling. Where possible users should run analog cables separately.
- Good cable shielding should be used. When terminating the shield at Earth - ensure that no earth loops are accidentally created.
- When reading analog values, EMC accuracy can be improved out by averaging the readings. This can be achieved either through functions on the analog special adapters or through a users program in the FX3U(C) Series PLC main unit.
- Attach the ferrite core input cable of each channel about FX3U-4AD-PNK-ADP as follows.

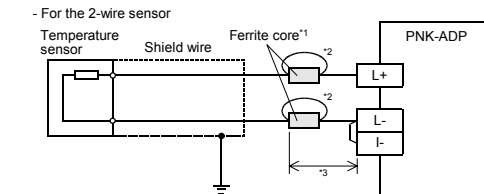
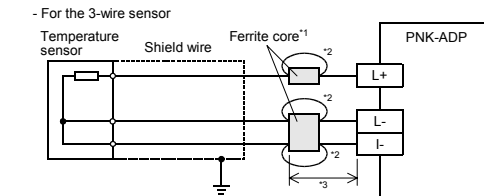

*1 Use the ferrite core which has the impedance characteristic of 150Ω or more in 100MHz to 500MHz range.

*2 Wrap the cable by 2 turns.

*3 Attach the ferrite core in approximately 200mm (0.78") or less from terminal block on the PNK-ADP side.

1. Outline

FX3U-4AD-PNK-ADP (hereinafter called PNK-ADP) is an analog special adapter for measuring temperature via four channels (2-wire or 3-wire sensors) of a connected Pt1000/Ni1000 resistance thermometer.

1.1 Incorporated Items

Verify that the following product and items are included in the package:

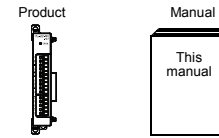

1.2 External Dimensions, Part Names, and Terminal Layout

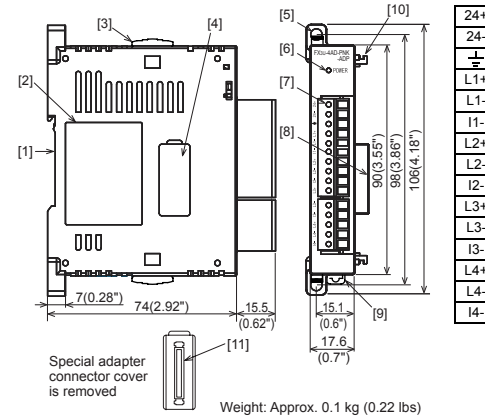

- [1] DIN rail mounting groove (DIN rail: DIN46277)
- [2] Name plate
- [3] Special adapter slide lock: Used to connect additional special adapters onto the left side of this special adapter.
- [4] Special adapter connector cover: Remove this cover to connect additional special adapters to the left side.
- [5] Direct mounting hole: 2 holes of φ4.5 (0.18") (mounting screw: M4 screw) Not used when connecting to FX3UC Series PLC.
- [6] POWER LED (green): Lit while 24V DC power is supplied properly to terminals '24+' and '24-'.
- [7] Terminal block (European type): Connect Pt1000 sensor, Ni1000 sensor and 24V DC power supply
- [8] Special adapter connector: Used to connect this special adapter to PLC main unit or special adapter.
- [9] DIN rail mounting hook
- [10] Special adapter fixing hook
- [11] Special adapter connector: Used to connect communication or analog special adapters to the left side of the PNK-ADP.

2. Installation

For installation/uninstallation details, refer to the following manuals:

- Refer to the **FX3U Series User's Manual - Hardware Edition**.
- Refer to the **FX3UC Series User's Manual - Hardware Edition**.

INSTALLATION PRECAUTIONS	⚠ DANGER
<ul style="list-style-type: none"> • Make sure to cut off all phases of the power supply externally before attempting installation or wiring work. Failure to do so may cause electric shock or damage to the product. 	
INSTALLATION PRECAUTIONS	⚠ CAUTION
<ul style="list-style-type: none"> • Use the product within the generic environment specifications described in PLC main unit manual (Hardware Edition). Never use the product in areas with excessive dust, oily smoke, conductive dusts, corrosive gas (salt air, Cl₂, H₂S, SO₂, or NO₂), flammable gas, vibration or impacts, or expose it to high temperature, condensation, or rain and wind. If the product is used in such conditions, electric shock, fire, malfunctions, deterioration or damage may occur. • When drilling screw holes or wiring, make sure cutting or wire debris does not enter the ventilation slits. Failure to do so may cause fire, equipment failures or malfunctions. • Do not touch the conductive parts of the product directly. Doing so may cause device failures or malfunctions. • Connect special adapter securely to their designated connectors. Loose connections may cause malfunctions. 	

2.1 Connection to the FX3U Series PLC Procedure

- Turn off the power. Disconnect all the cables connected to the PLC main unit and special adapter, and demount the main unit and special adapter mounted on DIN rail or mounted directly using screws.
- Install an expansion board to the main unit. For the expansion board installation procedure, refer to the following manual: → Refer to the **FX3U Series User's Manual - Hardware Edition**
- Remove the special adapter connector cover on the expansion board (fig.A). When connecting this product to another special adapter, please replace the 'expansion board' in the above description with a 'special adapter' and perform the procedure as indicated.
- Slide the special adapter slide lock (fig.B) of the main unit. When connecting this product to another special adapter, please replace the 'main unit' in the above description with a 'special adapter' and perform the procedure as indicated.
- Connect the special adapter (fig.C) to the main unit as shown on the right.
- Slide back the special adapter slide lock (fig.B) of the main unit to fix the special adapter (fig.C).

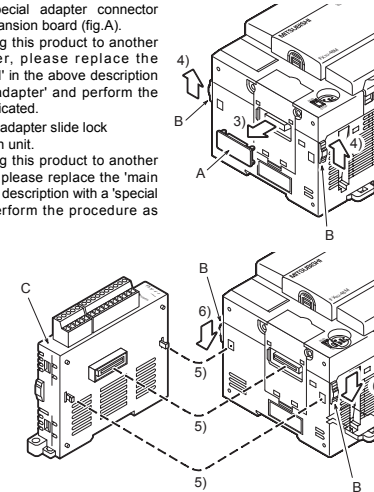

Connection precautions

Connect all the high-speed I/O special adapters before connecting other special adapters when they are used in combination. **Do not connect a high-speed I/O special adapter on the left side of a communication or analog special adapter.**

2.2 Connection to the FX3UC (D, DSS) Series PLC

Procedure

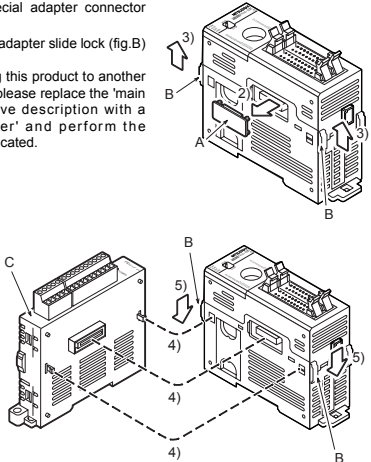
- Turn off the power.
Disconnect all the cables connected to the PLC, and demount the PLC from the DIN rail.
 - Remove the special adapter connector cover (fig.A)
 - Slide the special adapter slide lock (fig.B) of the main unit.
When connecting this product to another special adapter, please replace the 'main unit' in the above description with a 'special adapter' and perform the procedure as indicated.
 - Connect the special adapter (fig.C) to the main unit as shown on the right.
 - Slide back the special adapter slide lock (fig.B) of the main unit to fix the special adapter (fig.C).
- 

2.3 Connection to the FX3UC-32MT-LT PLC

Procedure

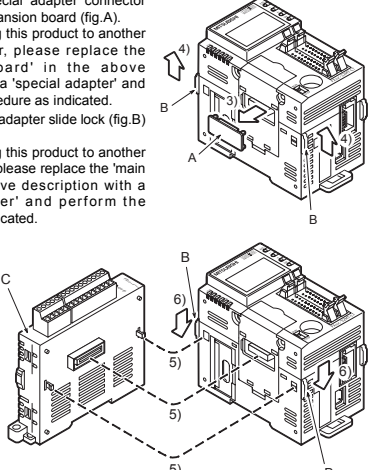
- Turn off the power.
Disconnect all the cables connected to the PLC, and demount the PLC from the DIN rail.
 - Install an expansion board to the main unit.
For the expansion board installation procedure, refer to the following manual:
→ Refer to the FX3UC Series User's Manual - Hardware Edition
 - Remove the special adapter connector cover on the expansion board (fig.A).
When connecting this product to another special adapter, please replace the 'expansion board' in the above description with a 'special adapter' and perform the procedure as indicated.
 - Slide the special adapter slide lock (fig.B) of the main unit.
When connecting this product to another special adapter, please replace the 'main unit' in the above description with a 'special adapter' and perform the procedure as indicated.
 - Connect the special adapter (fig.C) to the main unit as shown on the right.
 - Slide back the special adapter slide lock (fig.B) of the main unit to fix the special adapter (fig.C).
- 

3. Wiring

WIRING PRECAUTIONS	⚠ DANGER
<ul style="list-style-type: none"> Make sure to cut off all phases of the power supply externally before attempting installation or wiring work. Failure to do so may cause electric shock or damage to the product. 	

WIRING PRECAUTIONS	⚠ CAUTION
<ul style="list-style-type: none"> Make sure to cut off all phases of the power supply externally before attempting installation or wiring work. Failure to do so may cause electric shock or damage to the product. Make sure to observe the following precautions in order to prevent any damage to the machinery or accidents due to abnormal data written to the PLC under the influence of noise: <ol style="list-style-type: none"> Do not bundle the main circuit line together with or lay it close to the main circuit, high-voltage line or load line. Otherwise, noise disturbance and/or surge induction are likely to take place. As a guideline, lay the control line at least 100mm (3.94") or more away from the main circuit or high-voltage lines. Ground the shield wire or shield of the shielded cable at one point on the PLC. However, do not use common grounding with heavy electrical systems. Make sure to properly wire to the European terminal board in accordance with the following precautions. Failure to do so may cause electric shock, a short-circuit, wire breakage, or damage to the product. <ul style="list-style-type: none"> The disposal size of the cable end should be 9mm (0.35"). Tightening torque should be between 0.22 and 0.25N·m. Twist the end of strand wire and make sure that there are no loose wires. Do not solder-plate the electric wire ends. Do not connect more than the specified number of wires or electric wires of unspecified size. Affix the electric wires so that neither the terminal block nor the connected parts are directly stressed. Make sure to properly wire to the FX3U Series PLC in accordance with the following precautions. Failure to do so may cause electric shock, a short-circuit, wire breakage, or damage to the product. <ul style="list-style-type: none"> The disposal size of the cable end should follow the dimensions described in this manual. Tightening torque should follow the specifications in this manual. 	

3.1 Applicable cable and terminal tightening torque

3.1.1 Terminal block (European type)

- Wire size
 - The power supply wire should use 22-20 AWG wire.

Type	Wire size
Single-wire	0.3mm ² to 0.5mm ² (AWG22 to 20)
2-wire	2 pieces of 0.3mm ² (AWG22)

- Termination of cable end
Strip the coating of strand wire and twist the cable core before connecting it, or strip the coating of single wire before connecting it.
An alternative connection is to use a ferrule with insulating sleeve.

Manufacturer	Model	Pressure bonding tool
Phoenix Contact Co., Ltd.	AI 0.5-8WH	CRIMPFOX ZA 3 (or CRIMPFOX UD 6)

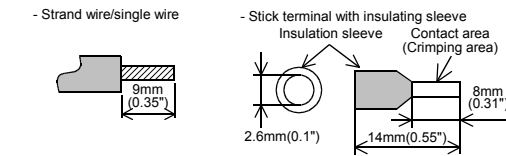

When using a stick terminal with insulating sleeve, choose a wire with proper cable sheath referring to the above outside dimensions, or otherwise, the wire cannot be inserted easily.
The tightening torque must be 0.22 to 0.25N·m.

3.2 Power Supply Wiring

Connect the 24V DC power supply line of the PNK-ADP to the 24+ and 24- terminals of the terminal block.

3.2.1 To connect to FX3U Series PLC

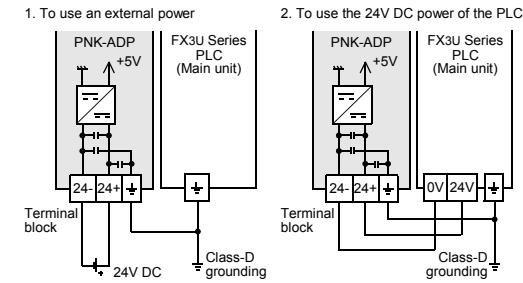

Caution regarding connection of the power supply line

- Ground the "±" terminal to a class-D grounding power supply line (100Ω or less) together with the ground terminal of the PLC main unit.
- For the timing of power-on/off when using an external power supply, see the following manual of the PLC to be connected.
→ Refer to the FX3U Series User's Manual - Hardware Edition.

3.2.2 To connect to FX3UC Series PLC

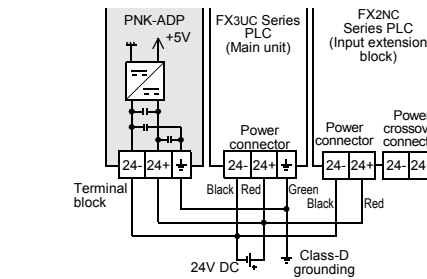

Caution regarding connection of the power supply line

- For the 24V DC power supply line, be sure to use the same power as the FX3UC Series PLC.
- Ground the "±" terminal to a class-D grounding power supply line (100Ω or less) together with the ground terminal of the PLC main unit.

3.3 Selection of resistance thermometer sensors

→ For the terminal layout, refer to Section 1.2

Precautions on resistance thermometer wiring

- When using a 2-wire temperature sensor type, short-circuit the [L-] terminal and the [I-] terminal. For the lead wire use a 10Ω resistance or less per line.
- Separate the cable of the resistance thermometer sensors from the other power cables or areas easily affected by inductive noise (of the commercial power, etc.).

Example of resistance thermometer wiring

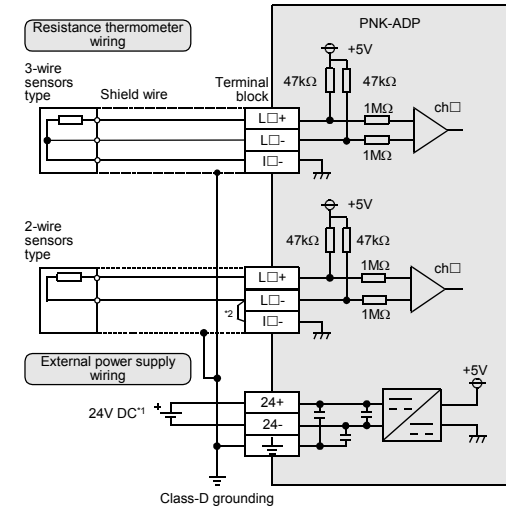

L+, L-, I-, ch□: □ represents the channel number.

- 24V DC service power supply of the FX3U Series PLC can also be used.
- When using a 2-wire temperature sensor type, short-circuit the [L-] terminal and the [I-] terminal.

3.4 Grounding

Grounding should be performed as stated below.

- The grounding resistance should be 100Ω or less.
- Independent grounding should be performed for best results.
When independent grounding is not performed, perform "shared" - of the following figure.

→ For details, refer to the FX3U Series User's Manual - Hardware Edition.

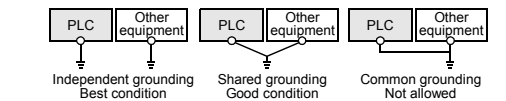

- The grounding wire size should be AWG 22-20 (0.3-0.5 mm²).
- The grounding point should be close to the PLC, and all grounding wire should be as short as possible.

4. Specifications

STARTUP AND MAINTENANCE PRECAUTIONS **CAUTION**

- Do not disassemble or modify the PLC. Doing so may cause fire, equipment failures, or malfunctions. * For repair, contact your local Mitsubishi Electric distributor.
- Do not drop the product or exert strong impact to it. Doing so may cause damage.

DISPOSAL PRECAUTIONS **CAUTION**

- Please contact a certified electronic waste disposal company for the environmentally safe recycling and disposal of your device.

TRANSPORT AND STORAGE PRECAUTIONS **CAUTION**

- The product is a precision instrument. During transportation, avoid any impacts. Failure to do so may cause failures in the product. After transportation, verify the operations of the product.

4.1 Applicable PLC

Model name	Applicability
FX3U Series PLC	Ver. 2.20 or later (from first production)
FX3UC Series PLC	Ver. 1.30 or later (from the production manufactured in August, 2004 with SER No. 48****)

The version number can be checked by monitoring D8001 as the last three digits indicate it.

4.2 General Specifications

For the general specifications, refer to the manual of the PLC main unit. The items other than the following are equivalent to those of the PLC main unit.

Item	Specification
Dielectric withstand voltage	500V AC for one minute Conforming to JEM-1021 Between all terminals and ground terminal of PLC main unit
Insulation resistance	5MΩ or more by 500V DC megger

4.3 Power Supply Specifications

Item	Specification
A/D conversion circuit driving power	24V DC +20%/-15%, 50mA for 24V DC Connect a 24V DC power supply to the terminal block.
Interface driving power	5V DC, 15mA 5V DC power is supplied from the internal power supply of main unit.

4.4 Performance Specifications

Item	Description			
	Centigrade (°C)		Fahrenheit (°F)	
Input signal	Platinum resistance thermometer sensor (2-wire or 3-wire) Pt1000 JIS C 1604-1997			
	Nickel resistance thermometer sensor (2-wire or 3-wire) Ni1000 DIN 43760-1987			
Rated temperature range	Pt1000	-50°C to +250°C	Pt1000	-58°F to +482°F
	Ni1000	-40°C to +110°C	Ni1000	-40°F to +230°F
Digital output	Pt1000	-500 to +2500	Pt1000	-580 to +4820
	Ni1000	-400 to +1100	Ni1000	-400 to +2300
Resolution	Pt1000	0.1°C	Pt1000	0.2°F
	Ni1000			
Total accuracy	±0.5% for full scale (when ambient temperature is 25°C±5°C) ±1.0% for full scale (when ambient temperature is in the range of 0 to 55°C)			
A/D conversion time	200μs (The data will be updated at every scan time of the PLC.)			

Item	Description	
	Centigrade (°C)	Fahrenheit (°F)
Input characteristics		
Insulation method	<ul style="list-style-type: none"> The photo-coupler is adopted to insulate the analog input area from the PLC. The DC/DC converter is adopted to insulate the driving power supply line from the analog input area. Channels are not insulated from each other. 	
Occupied points	0 point (This number is not related to the maximum number of input/output points of the PLC.)	

4.5 A/D Conversion Time

This section describes the A/D conversion time.

- A/D conversion and special data register update timing
During execution of END instruction, the PLC performs A/D conversion, reads out the A/D converted data, and then writes the data in the special data registers.

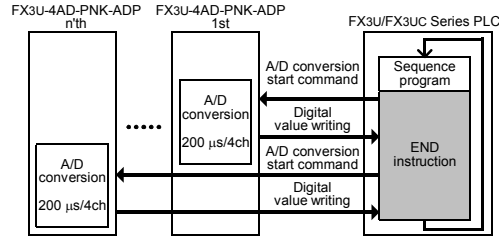

- A/D conversion during PLC stop
Even if the PLC is stopped, A/D conversion will be performed and the special data registers will be updated.
- If two or more analog special adapters are connected
During execution of the END instruction, data will be read out from all the connected adapters (in the order of 1st adapter → 2nd adapter ... 4th adapter).
- A/D conversion speed (data update time)
During execution of the END instruction, the A/D converted data of all 4 channels will be read out in 200μs, and the data read out will be written to the special data registers.
END instruction execution time will be "200μs × number of connected adapters."

4.6 Temperature Measurement

To stabilize the temperature measurement, warm-up the system for 30 minutes or more after power-on.

5. Programming

This chapter describes how to create programs that can read analog data using the PNK-ADP.

5.1 Loading of A/D Conversion Data

- The input analog data will be converted into digital data and then stored in the special devices of the FX3U/FX3UC Series PLC.
- If data is stored in the special devices, the averaging time can be set, and the input mode can be specified.
- Special auxiliary relays (10 points) and special data registers (10 points) are assigned automatically starting from the adapter nearest to the main unit.
→ For a detailed description of special device assignment, refer to Section 5.2.

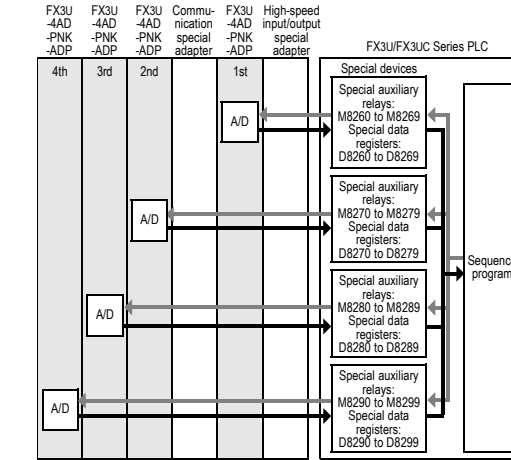

- The analog special adapter nearest to the main unit is counted as the 1st analog special adapter, and the next adapter as the 2nd analog special adapter, and so on. However, in this case, do not include the high-speed input/output special adapter and the communication special adapter.

5.2 List of Special Devices

If PNK-ADP is connected, special devices will be assigned automatically as shown in the following table

Special auxiliary relay				Description	Attribute	Refer to
1st	2nd	3rd	4th			
M8260	M8270	M8280	M8290	Selects the temperature unit	R/W	5.3
M8261	M8271	M8281	M8291	Input sensor selection	R/W	5.4
M8262 to M8269	M8272 to M8279	M8282 to M8289	M8292 to M8299	Unused (Do not use.)	-	-

Special data register				Description	Attribute	Refer to
1st	2nd	3rd	4th			
D8260	D8270	D8280	D8290	Channel-1 temperature measurement data	R	5.5
D8261	D8271	D8281	D8291	Channel-2 temperature measurement data	R	
D8262	D8272	D8282	D8292	Channel-3 temperature measurement data	R	
D8263	D8273	D8283	D8293	Channel-4 temperature measurement data	R	
D8264	D8274	D8284	D8294	Averaging time for channel 1	R/W	5.6
D8265	D8275	D8285	D8295	Averaging time for channel 2	R/W	
D8266	D8276	D8286	D8296	Averaging time for channel 3	R/W	
D8267	D8277	D8287	D8297	Averaging time for channel 4	R/W	
D8268	D8278	D8288	D8298	Error status	R/W	5.7
D8269	D8279	D8289	D8299	Model code = K11	R	5.8

5.3 Selection of Temperature Unit

To switch the temperature unit of the PNK-ADP turn the special auxiliary relay ON for Fahrenheit (°F) or OFF for Centigrade (°C). The input sensor type will be selected for all the channels at the same time. To select the selection of temperature unit, use the following special auxiliary relays.

Special auxiliary relay				Description
1st	2nd	3rd	4th	
M8260	M8270	M8280	M8290	Selection of temperature unit OFF: Centigrade (°C) ON: Fahrenheit (°F)

Program Example

- To switch the temperature unit to centigrade (°C) for the 1st adapter:

```

M8001
|---| I
|---( ) M8260
Normally OFF

```
- To switch the temperature unit to Fahrenheit (°F) for the 2nd adapter:

```

M8000
|---| I
|---( ) M8270
Normally ON

```

5.4 Input sensor selection

Turn on the Pt1000 type or off the Ni1000 type selection special auxiliary relay to select the Pt1000 or Ni1000 for PNK-ADP. The input sensor type will be selected for all the channels at the same time. To select the input sensor type, use the following special auxiliary relays.

Special auxiliary relay				Description
1st	2nd	3rd	4th	
M8261	M8271	M8281	M8291	Input sensor selection OFF: Pt1000 ON: Ni1000

Program Example

- To select Pt1000 for the 1st adapter:

```

M8001
|---| I
|---( ) M8261
Normally OFF

```
- To select Ni1000 for the 2nd adapter:

```

M8000
|---| I
|---( ) M8271
Normally ON

```

5.5 Temperature Measurement

The temperature data input in the PNK-ADP will be stored in the special data registers. The special data registers that store the temperature data are shown in the following table.

Special data register				Description
1st	2nd	3rd	4th	
D8260	D8270	D8280	D8290	Stores the channel-1 temperature measurement data.
D8261	D8271	D8281	D8291	Stores the channel-2 temperature measurement data.
D8262	D8272	D8282	D8292	Stores the channel-3 temperature measurement data.
D8263	D8273	D8283	D8293	Stores the channel-4 temperature measurement data.

The immediate data or the average data (data averaged in accordance with the specified averaging time) will be stored in the above data registers as the temperature measurement data.

→ For a detailed description of the averaging time, refer to Section 5.6.

- Caution regarding temperature measurement
The temperature measurement data are for reading only. Do not change (rewrite) the current data using the sequence program, indicator, or device monitor of the programming tool.

2) Program Example

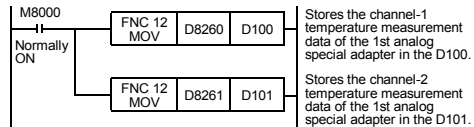

Even if the temperature measurement data is not stored in the D100 or the D101, the D8260 or the D8261 can be directly used in the arithmetic operation instruction or a PID instruction.

5.6 Averaging Time

If the averaging time is set for the PNK-ADP, the averaged temperature measurement data will be stored in the D8260 to D8263, D8270 to D8273, D8280 to D8283, and D8290 to D8293. The averaging time can be set for each channel. Set the averaging time in the following special data registers.

Special data register				Description	Initial value	Setting range
1st	2nd	3rd	4th			
D8264	D8274	D8284	D8294	Averaging time for channel-1 data	K64	1 to 4095
D8265	D8275	D8285	D8295	Averaging time for channel-2 data	K64	1 to 4095
D8266	D8276	D8286	D8296	Averaging time for channel-3 data	K64	1 to 4095
D8267	D8277	D8287	D8297	Averaging time for channel-4 data	K64	1 to 4095

1) Cautions regarding averaging time setting

- If the averaging time is set to "1", the immediate data will be stored in the temperature measurement special data register.
- If the averaging time is set to "2" or more, the average value will be calculated in accordance with the set averaging time, and the average value obtained will be stored in the temperature measurement special data register.
- After turning the PLC power on, the average data will be stored in the temperature measurement special data registers (D8260 to D8263, D8270 to D8273, D8280 to D8283, and D8290 to D8293) until the number of data items is increased to the set averaging time.
- Set the averaging time in the range from 1 to 4095. If the set value is outside the setting range, the error signal will be output.
→ For a detailed description of error status, refer to Section 5.7

2) Program Example



5.7 Error Status

If an error is detected in the PNK-ADP, the error status data will be stored in the corresponding special data register. The following table shows the special data registers that store the error status data.

Special data register				Description
1st	2nd	3rd	4th	
D8268	D8278	D8288	D8298	Stores the error status data.

Check the ON/OFF status of each bit of the error status data register to determine the error. Errors are assigned to the bits as shown in the following table. Create a program to detect errors.

Bit	Description
b0	The temperature measurement data in channel 1 is outside the specified range, or disconnection is detected.
b1	The temperature measurement data in channel 2 is outside the specified range, or disconnection is detected.
b2	The temperature measurement data in channel 3 is outside the specified range, or disconnection is detected.
b3	The temperature measurement data in channel 4 is outside the specified range, or disconnection is detected.
b4	EEPROM error
b5	Averaging time setting error
b6	PNK-ADP hardware error
b7	PNK-ADP communication data error
b8 to b15	Unused

1) Caution regarding use of error status data

If a PNK-ADP hardware error (b6) or PNK-ADP communication data error (b7) is detected, it is necessary to clear the error status with a program at the next power-on of the PLC.

For this reason, be sure to create the following program

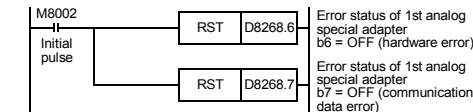

2) Program Example

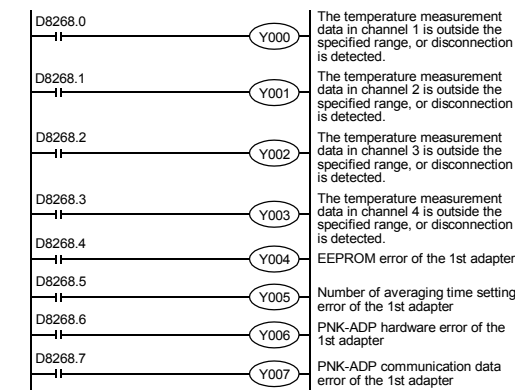

5.8 Model Code

When the PNK-ADP is connected, model code "11" will be stored in the corresponding special data register.

The following table shows the special data registers that store the model code

Special data register				Description
1st	2nd	3rd	4th	
D8269	D8279	D8289	D8299	Model code

Use the special data registers above to check whether PNK-ADP is connected or not.

- Program Example

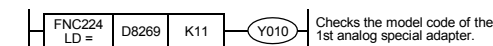

5.9 Basic Program Example

Create the following basic program to read out the temperature measurement data. The following program will select Pt1000 and will store the temperature measurement data (°C) of channels 1 and 2 of the 1st adapter in the D100 and the D101, respectively. The averaging time will be set to "32" for channel 1, and "128" for channel 2.

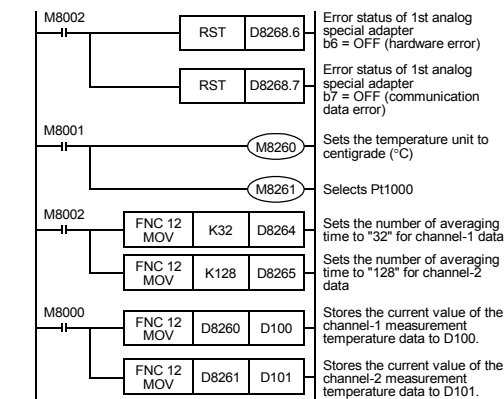

Even if the temperature measurement data is not stored in the D100 or the D101, the D8260 or the D8261 can be directly used in the arithmetic operation instruction or a PID instruction.

6. Troubleshooting

This chapter describes the troubleshooting methods and error status.

If the temperature measurement data is not input, or if the proper digital value is not input, check the following items:

- Version number of the PLC
- Wiring
- Special devices
- Programs
- Error status

6.1 PLC Version Number Check

- Any versions (from Ver.2.20 (initial version) to the latest version) of the FX3U Series are compatible.
- Check the version number of FX3UC Series. The version number should be 1.30 or later.
→ For the version check method, refer to the manual of the PLC main unit.

6.2 Wiring Check

Check the following items for wiring.

- Power
The PNK-ADP needs driving power. Verify that the power supply line is properly connected. Also check that the POWER indicator lamp of the PNK-ADP is on.
- Resistance thermometer sensor cable
When using a 2-wire temperature sensor type, short-circuit the [-] terminal and the [-] terminal.
Separate the cable of the resistance thermometer sensor from the other power cables or areas easily affected by inductive noise (of the commercial power, etc.).
→ For a detailed description of wiring, refer to Chapter 3.

6.3 Special Device Check

Check whether the special devices for the PNK-ADP are correctly used

- Input sensor selection
Check if the special device for type Pt1000/Ni1000 selection is correctly set.
Turn off the device to select Pt1000.
Turn on the device to select Ni1000.
- Temperature measurement
Check if the special device of the selected channel is correctly set.
This special device should be selected depending on the connecting position and the channel.
- Averaging time
Verify if the set averaging time is within the specified range. The averaging time should be set in the range from 1 to 4095. If the set averaging time is outside the specified range, an error occurs.
- Error status
Check that no error is detected in the PNK-ADP.
If an error is detected, check the details of the error, and then check the wiring and programs.
→ For a detailed description of special devices, refer to Chapter 5.

6.4 Program Check

Check the following items for the program:

- Cancellation of error status at power-on
When the power is turned off and then on again, the error status should be cleared (the b6 and the b7 should turn off) using the program.
- Check of storage devices
Verify that different values are not being stored in the same device by the other parts of the programs.

6.5 Error Status Check

If an error occurs in the PNK-ADP, the corresponding bit will turn on.

Bit	Description
b0	The temperature measurement data in channel 1 is outside the specified range, or disconnection is detected.
b1	The temperature measurement data in channel 2 is outside the specified range, or disconnection is detected.
b2	The temperature measurement data in channel 3 is outside the specified range, or disconnection is detected.
b3	The temperature measurement data in channel 4 is outside the specified range, or disconnection is detected.
b4	EEPROM error
b5	Averaging time setting error
b6	PNK-ADP hardware error
b7	PNK-ADP communication data error
b8	Unused

To solve a problem, refer to the troubleshooting method described below

- Temperature measurement out of specified range or disconnection of line (b0 to b3)
 - Description of error
The input temperature measurement value is outside the specified range. The temperature measurement value of Pt1000 is not in the range between -55°C to +256°C, or the temperature measurement value of Ni1000 is not in the range between -45°C to +115°C. Alternatively, wiring with Pt1000 and Ni1000 is disconnected.

- Remedy
Check that the input temperature measurement value is within the specified range. Also check the wiring condition.

2) EEPROM error (b4)

- Description of error
The adjustment data set in the EEPROM before delivery from our factory is unreadable or is destroyed.
- Remedy
Please contact the nearest Mitsubishi Electric distributor office.

3) Averaging time setting error (b5)

- Description of error
The averaging time set for one of the channels (channels 1 to 4) is outside the specified range: 1 to 4095.
- Remedy
Check that the averaging time is correctly set for each channel.

4) PNK-ADP hardware error (b6)

- Description of error
The PNK-ADP does not operate properly.
- Remedy
Check that the 24V DC power is properly supplied to the PNK-ADP. Also check that the PNK-ADP is correctly connected to the PLC.
If the problem cannot be solved even after the above check, please contact the nearest Mitsubishi Electric distributor office.

5) PNK-ADP communication data error (b7)

- Description of error
A communication error is detected between the PNK-ADP and the PLC.
- Remedy
Check that the PNK-ADP is correctly connected to the PLC.
If the problem cannot be solved even after the above check, please contact the nearest Mitsubishi Electric distributor office.

This manual confers no industrial property rights or any rights of any other kind, nor does it confer any patent licenses. Mitsubishi Electric Corporation cannot be held responsible for any problems involving industrial property rights which may occur as a result of using the contents noted in this manual.

Warranty

Mitsubishi will not be held liable for damage caused by factors found not to be the cause of Mitsubishi; opportunity loss or lost profits caused by faults in the Mitsubishi products; damage, secondary damage, accident compensation caused by special factors unpredictable by Mitsubishi; damages to products other than Mitsubishi products; and to other duties.

⚠ For safe use

- This product has been manufactured as a general-purpose part for general industries, and has not been designed or manufactured to be incorporated in a device or system used in purposes related to human life.
- Before using the product for special purposes such as nuclear power, electric power, aerospace, medicine or passenger movement vehicles, consult with Mitsubishi Electric.
- This product has been manufactured under strict quality control. However when installing the product where major accidents or losses could occur if the product fails, install appropriate backup or failsafe functions in the system.

MITSUBISHI ELECTRIC CORPORATION

HEAD OFFICE : TOKYO BUILDING, 2-7-3 MARUNOUCHI, CHIYODA-KU, TOKYO 100-8310, JAPAN
HIMEJI WORKS : 840, CHIYODA CHO, HIMEJI, JAPAN

4. Specifications

STARTUP AND MAINTENANCE PRECAUTIONS CAUTION Do not disassemble or modify the PLC. Doing so may cause fire, equipment failures, or malfunctions.

DISPOSAL PRECAUTIONS CAUTION Please contact a certified electronic waste disposal company for the environmentally safe recycling and disposal of your device.

TRANSPORT AND STORAGE PRECAUTIONS CAUTION The product is a precision instrument. During transportation, avoid any impacts.

4.1 Applicable PLC

Table with columns: Model name, Applicability. Includes FX3U Series PLC and FX3UC Series PLC with their respective version requirements.

The version number can be checked by monitoring D8001 as the last three digits indicate it.

4.2 General Specifications

For the general specifications, refer to the manual of the PLC main unit. The items other than the following are equivalent to those of the PLC main unit.

Table with columns: Item, Specification. Lists dielectric withstand voltage, insulation resistance, and interface driving power.

4.3 Power Supply Specifications

Table with columns: Item, Specification. Details A/D conversion circuit driving power, interface driving power, and A/D conversion time.

4.4 Performance Specifications

Table with columns: Item, Description. Covers input signal, rated temperature range, digital output, resolution, total accuracy, and A/D conversion time.

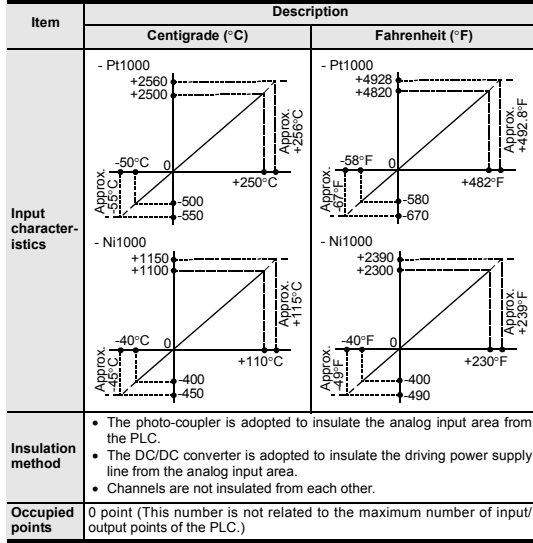

4.5 A/D Conversion Time

This section describes the A/D conversion time. During execution of the END instruction, the PLC performs A/D conversion, reads out the A/D converted data, and then writes the data in the special data registers.

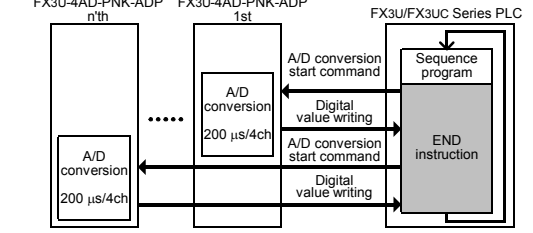

- 2) A/D conversion during PLC stop
3) If two or more analog special adapters are connected
4) A/D conversion speed (data update time)

4.6 Temperature Measurement

To stabilize the temperature measurement, warm-up the system for 30 minutes or more after power-on.

5. Programming

This chapter describes how to create programs that can read analog data using the PNK-ADP.

5.1 Loading of A/D Conversion Data

- 1) The input analog data will be converted into digital data and then stored in the special devices of the FX3U/FX3UC Series PLC.
2) If data is stored in the special devices, the averaging time can be set, and the input mode can be specified.
3) Special auxiliary relays (10 points) and special data registers (10 points) are assigned automatically starting from the adapter nearest to the main unit.

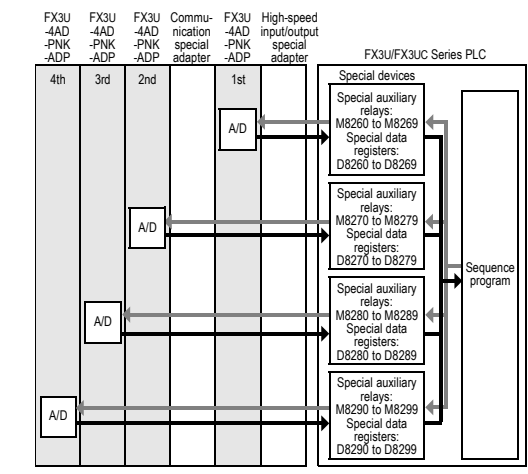

The analog special adapter nearest to the main unit is counted as the 1st analog special adapter, and the next adapter as the 2nd analog special adapter, and so on.

5.2 List of Special Devices

If PNK-ADP is connected, special devices will be assigned automatically as shown in the following table.

Table listing special devices: M8260-M8290 (Temperature unit selection), M8261-M8291 (Input sensor selection), and M8262-M8292 (Unused).

Special data register

Table listing special data registers D8260-D8299 with descriptions for temperature measurement data, averaging time, and error status.

5.3 Selection of Temperature Unit

To switch the temperature unit of the PNK-ADP turn the special auxiliary relay ON for Fahrenheit (°F) or OFF for Centigrade (°C).

Table for Special auxiliary relay selection, showing bit assignments for Centigrade and Fahrenheit units.

Program Example

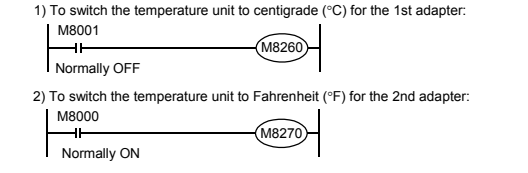

5.4 Input sensor selection

Turn on the Pt1000 type or off the Ni1000 type selection special auxiliary relay to select the Pt1000 or Ni1000 for PNK-ADP.

Table for Special auxiliary relay selection, showing bit assignments for Pt1000 and Ni1000 sensors.

Program Example

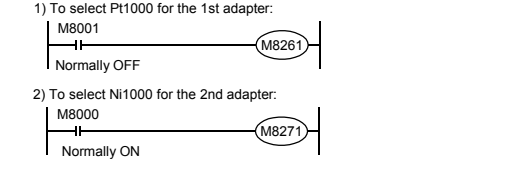

5.5 Temperature Measurement

The temperature data input in the PNK-ADP will be stored in the special data registers. The special data registers that store the temperature data are shown in the following table.

Table for Special data register description, mapping registers D8260-D8299 to channel and averaging time.

The immediate data or the average data (data averaged in accordance with the specified averaging time) will be stored in the above data registers as the temperature measurement data.

- 1) Caution regarding temperature measurement
The temperature measurement data are for reading only. Do not change (rewrite) the current data using the sequence program, indicator, or device monitor of the programming tool.

2) Program Example

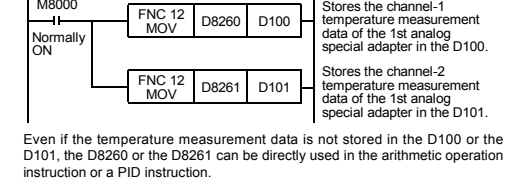

5.6 Averaging Time

If the averaging time is set for the PNK-ADP, the averaged temperature measurement data will be stored in the D8260 to D8263, D8270 to D8273, D8280 to D8283, and D8290 to D8293.

Table for Special data register averaging time settings, showing register numbers and settings for channels 1-4.

1) Cautions regarding averaging time setting

- If the averaging time is set to "1", the immediate data will be stored in the temperature measurement special data register.
- If the averaging time is set to "2" or more, the average value will be calculated in accordance with the set averaging time, and the average value obtained will be stored in the temperature measurement special data register.
- After turning the PLC power on, the average data will be stored in the temperature measurement special data registers (D8260 to D8263, D8270 to D8273, D8280 to D8283, and D8290 to D8293) until the number of data items is increased to the set averaging time.

2) Program Example

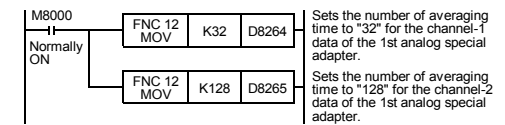

5.7 Error Status

If an error is detected in the PNK-ADP, the error status data will be stored in the corresponding special data register. The following table shows the special data registers that store the error status data.

Table for Special data register error status, showing registers D8268-D8298 and their descriptions.

Check the ON/OFF status of each bit of the error status data register to determine the error. Errors are assigned to the bits as shown in the following table. Create a program to detect errors.

Table for Error Status bit descriptions, mapping bits b0-b8 to specific error conditions.

1) Caution regarding use of error status data

If a PNK-ADP hardware error (b6) or PNK-ADP communication data error (b7) is detected, it is necessary to clear the error status with a program at the next power-on of the PLC.

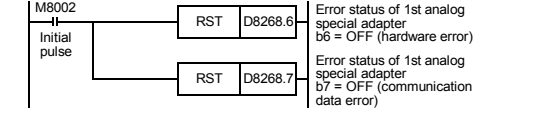

2) Program Example

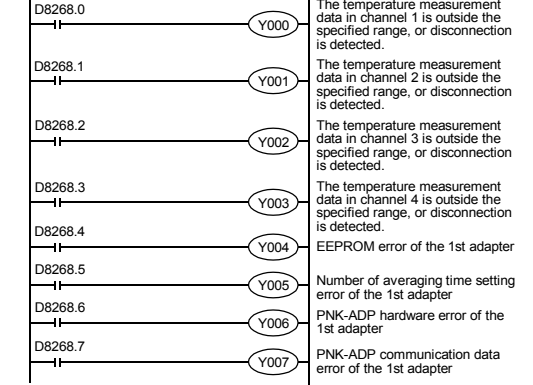

5.8 Model Code

When the PNK-ADP is connected, model code "11" will be stored in the corresponding special data register. The following table shows the special data registers that store the model code.

Table for Special data register model code, showing register D8269 and its description.

Use the special data registers above to check whether PNK-ADP is connected or not.



5.9 Basic Program Example

Create the following basic program to read out the temperature measurement data. The following program will select Pt1000 and will store the temperature measurement data (°C) of channels 1 and 2 of the 1st adapter in the D100 and the D101, respectively.

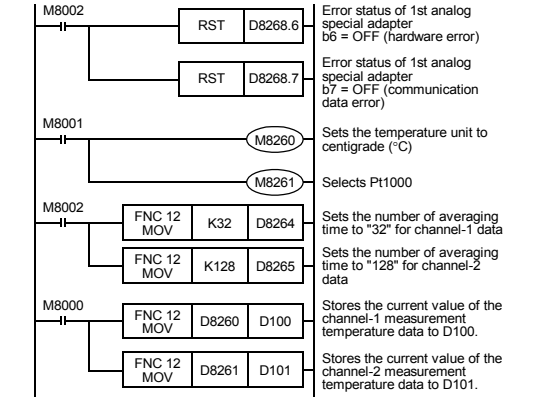

Even if the temperature measurement data is not stored in the D100 or the D101, the D8260 or the D8261 can be directly used in the arithmetic operation instruction or a PID instruction.

6. Troubleshooting

This chapter describes the troubleshooting methods and error status. If the temperature measurement data is not input, or if the proper digital value is not input, check the following items:

- Version number of the PLC
• Wiring
• Special devices
• Programs
• Error status

6.1 PLC Version Number Check

- Any versions (from Ver.2.20 (initial version) to the latest version) of the FX3U Series are compatible.
• Check the version number of FX3UC Series. The version number should be 1.30 or later.

6.2 Wiring Check

- 1) Power: The PNK-ADP needs driving power. Verify that the power supply line is properly connected.
2) Resistance thermometer sensor cable: When using a 2-wire temperature sensor type, short-circuit the [-] terminal and the [-] terminal.
3) EEPROM error of the 1st adapter: Check that the averaging time is correctly set for each channel.

6.3 Special Device Check

- 1) Input sensor selection: Check if the special device for type Pt1000/Ni1000 selection is correctly set.
2) Temperature measurement: Check if the special device of the selected channel is correctly set.
3) Averaging time: Verify if the set averaging time is within the specified range.
4) Error status: Check that no error is detected in the PNK-ADP.

6.4 Program Check

- 1) Cancellation of error status at power-on: When the power is turned off and then on again, the error status should be cleared.
2) Check of storage devices: Verify that different values are not being stored in the same device by the other parts of the programs.

6.5 Error Status Check

If an error occurs in the PNK-ADP, the corresponding bit will turn on.

Table for Error Status bit descriptions, mapping bits b0-b8 to specific error conditions.

To solve a problem, refer to the troubleshooting method described below. 1) Temperature measurement out of specified range or disconnection of line (b0 to b3): a) Description of error: The input temperature measurement value is outside the specified range.

This manual confers no industrial property rights or any rights of any other kind, nor does it confer any patent licenses.

Warranty Mitsubishi will not be held liable for damage caused by factors found not to be the cause of Mitsubishi; opportunity loss or lost profits caused by faults in the Mitsubishi products; damage, secondary damage, accident compensation caused by special factors unpredictable by Mitsubishi; damages to products other than Mitsubishi products; and to other duties.

For safe use warning box containing safety instructions and quality control information.