

FX_{2N}

This manual contains text, diagrams and explanations which will guide the reader in the correct installation and operation of the FX_{2N}-4AD-TC special function block and should be read and understood before attempting to install or use the unit.

Further information can be found in the FX PROGRAMMING MANUAL(II) and FX_{0N}/FX_{1N}/FX_{2N}/FX_{2NC} SERIES HARDWARE MANUAL.

Guidelines for the Safety of the User and Protection of the FX_{2N}-4AD-TC special function block.

This manual should be used by trained and competent personnel. The definition of such a person or persons is as follows:

- a) Any engineer using the product associated with this manual, should be of a competent nature, trained and qualified to the local and national standards. These engineers should be fully aware of all aspects of safety with regards to automated equipment.
- b) Any commissioning or service engineer must be of a competent nature, trained and qualified to the local and national standards.
- c) All operators of the completed equipment should be trained to use this product in a safe and coordinated manner in compliance to established safety practices.

Note: The term 'completed equipment' refers to a third party constructed device which contains or uses the product associated with this manual.

Notes on the Symbols Used in this Manual

At various times throughout this manual certain symbols will be used to highlight points of information which are intended to ensure the users personal safety and protect the integrity of equipment.



- 1) Indicates that the identified danger **WILL** cause physical and property damage.



- 2) Indicates that the identified danger could **POSSIBLY** cause physical and property damage.

- Under no circumstances will Mitsubishi Electric be liable or responsible for any consequential damage that may arise as a result of the installation or use of this equipment.
- All examples and diagrams shown in this manual are intended only as an aid to understanding the text, not to guarantee operation. Mitsubishi Electric will accept no responsibility for the actual use of the product based on these illustrative examples.
- Owing to the very great variety in possible applications for this equipment, you must satisfy yourself as to its suitability for your own specific application.

1. INTRODUCTION

- The FX_{2N}-4AD-TC analog block amplifies the signal from four thermocouple sensors (Type K or J) and converts the data into 12 bit readings stored in the main unit. Both Centigrade (°C) and Fahrenheit (°F) can be read.
Reading resolution is 0.4°C/0.72°F of Type K and 0.3°C/0.54°F of Type J.
- The FX_{2N}-4AD-TC can connected to the FX_{0N}, FX_{1N}, FX_{2N} and the FX_{2NC} series Programmable Controllers (PLC).
- All data transfers and parameter settings are adjusted via software control of the FX_{2N}-4AD-TC; by use of the TO/FROM applied instructions in the PLC.
- The FX_{2N}-4AD-TC occupies 8 I/O points on the PLC expansion bus. The 8 I/O points can be allocated from either inputs or outputs. The FX_{2N}-4AD-TC draws 40mA from the 5V rail of the main unit or powered extension unit.
- Thermocouples with the following specifications can be used: Type K (JIS 1602-1981)
Type J (JIS 1602-1981)

2. EXTERNAL DIMENSIONS

Weight: Approx. 0.3 kg (0.66 lbs)

Dimensions: mm (inches)

Accessories: Self adhesive labels for special function block number identification

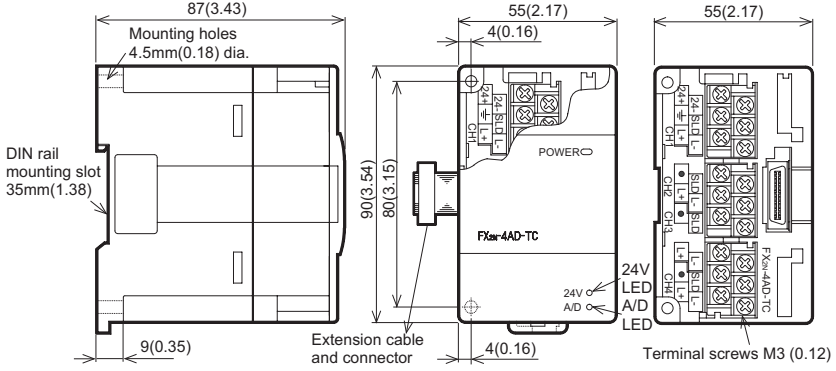

3. CONNECTION WITH PLC

3.1 Connection with PLC

1) Up to 4 FX2N-4AD-TC units can connect to the FX0N series PLC, up to 5 for FX1N, up to 8 for FX2N or, up to 4 for an FX2NC series PLC, all with powered extension units. However the following limitation exists when the undermentioned special function blocks are connected.

FX2N: Main unit and powered extension units of 32 I/O points or less. Current consumption available for the undermentioned special function blocks $\leq 190\text{mA}$

FX2N: Main unit and powered extension units of 48 I/O points or more. Current consumption available for the undermentioned special function blocks $\leq 300\text{mA}$

FX2NC: Up to 4 undermentioned special function blocks can be connected regardless of the system I/O. When using an FX2NC an FX2NC-CNV-IF is required.

FX0N/1N: Main unit and powered extension units. Up to 2 undermentioned special function blocks can be connected regardless of the system I/O.

- Each block occupies 8 I/O points (The 8 points can be allocated from either inputs or outputs).
- FX2N-4AD-TC consumes 40mA from the 5V DC bus. The total 5V consumption of all special function blocks connected to a main unit or extension unit must not exceed the 5V source capacity of the system.
- The FX2N-4AD-TC and main unit are connected by a cable on the right of the main unit.

3.2 Special function block numbers

Other special units of blocks that use FROM/TO commands, such as analog input blocks, analog output blocks and high-speed counter blocks, can be directly connected to the main unit of the PLC or to the right side of other extension blocks or units.

Connection example

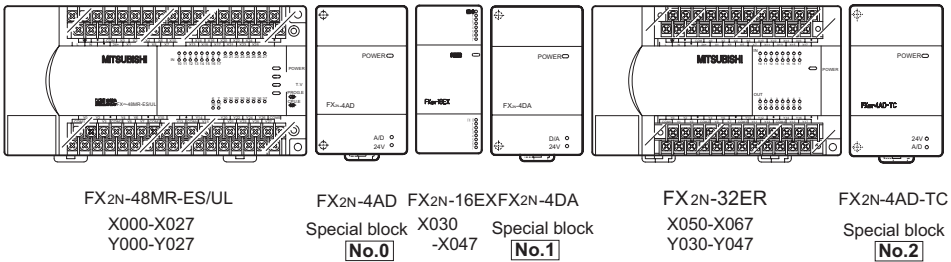

4. WIRING

4.1 Wiring

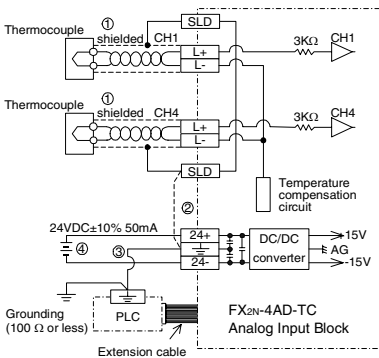

*1: The compensating cables that can be used for connecting with the thermocouple are the following.

Type K: KX-G, KX-GS, KX-H, KX-HS, WX-G, WX-H, VX-G
Type J: JX-G, JX-H

For every 10Ω of line resistance, the compensating cable will indicate a temperature 0.12°C higher than actual.

Check the line resistance before using. Long compensating cables are more prone to noise interference, therefore a short (less than 100m) compensating cable is recommended.

Unused channels should have a wire link connected between the + and - terminals to prevent an errors being detected on that channel.

*2: If there is excessive electrical noise, connect the SLD terminal to the ground terminal on the unit.

*3: Connect the ground terminals of the FX2N-4AD-TC unit and the main unit. Use grounding on the main unit.

*4: The 24V DC built-in supply of the PLC may be used as the power supply.

4.2 Using crimp terminations

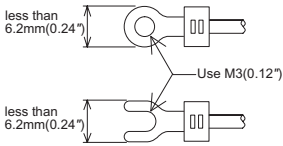

- Use crimp terminals as indicated on the left.
- Secure the terminal using a tightening torque of between 5 and 8 kg.cm.
- Wire only to the module terminals discussed in this manual. Leave all others vacant.

5. SPECIFICATIONS

5.1 Environmental specification

Item	Specification
Environmental specifications	Same as those for the main unit
Dielectric withstand voltage	500V AC, 1min (between all terminals and ground)

5.2 Power supply specification

Item	Specification
Analog circuits	24V DC \pm 10%, 60mA
Digital circuits	5V DC, 40mA (internal power supply from the main unit)

5.3 Performance specification

Analog Inputs

Item	Centigrade ($^{\circ}$ C)		Fahrenheit ($^{\circ}$ F)	
	Both $^{\circ}$ C and $^{\circ}$ F are available by reading the appropriate buffer memory (BFM).			
Input signal	Thermocouple: Type K or J (either can be used for each channel), 4 channels, JIS 1602-1981			
Rated temperature range	Type K	-100 $^{\circ}$ C to +1,200 $^{\circ}$ C	Type K	-148 $^{\circ}$ F to +2,192 $^{\circ}$ F
	Type J	-100 $^{\circ}$ C to +600 $^{\circ}$ C	Type J	-148 $^{\circ}$ F to +1,112 $^{\circ}$ F
Digital output	12 bit conversion stored in 16 bit 2's complement form			
	Type K	-1,000 to 12,000	Type K	-148 $^{\circ}$ F to +2,192 $^{\circ}$ F
Resolution	Type K	0.4 $^{\circ}$ C	Type K	0.72 $^{\circ}$ F
	Type J	0.3 $^{\circ}$ C	Type J	0.54 $^{\circ}$ F
Overall accuracy	\pm (0.5% full scale + 1 $^{\circ}$ C)			
Calibration point	Freezing point of pure water 0 $^{\circ}$ C / 32 $^{\circ}$ F			
Conversion speed	(240ms \pm 2%) \times 4 channels (unused channels are not converted)			

Item	Centigrade ($^{\circ}$ C)	Fahrenheit ($^{\circ}$ F)
Conversion Characteristics		
Readings given at calibration reference point 0 $^{\circ}$ C/32 $^{\circ}$ F (0/320) respectively. (subject to the overall accuracy)		

Miscellaneous

Item	Specification
Isolation	Photo-coupler isolation between analog and digital circuits. DC/DC converter isolation of power from main unit. No isolation between analog channels.
Number of occupied I/O points	The block occupies 8 I/O points (can be either inputs or outputs)

Note: Earth-tipped thermocouples are not suitable for use with this unit.

5.4 Installation location

This unit measures temperature according to the temperature difference between the temperature measurement part (thermocouple) and the terminal block. If this unit is installed at a place where the temperature of the terminal block varies rapidly, a measuring error may occur. For this reason, the unit should be installed at a place free from excessive temperature variation.

6. ALLOCATION OF BUFFER MEMORIES (BFM)

6.1 Buffer memories

BFM	CONTENTS
*#0	Thermocouple Type K or J selection mode. At shipment: H0000
*# 1 - #4	CH1 to CH4 Averaged temperature reading to be averaged (1 to 256) Default = 8
#5 - #8	CH1 to CH4 Averaged temperature in 0.1°C units
#9 - #12	CH1 to CH4 Present temperature in 0.1°C units
#13 - #16	CH1 to CH4 Averaged temperature in 0.1°F units
#17 - #20	CH1 to CH4 Present temperature in 0.1°F units
#21 - #27	Reserved
*#28	Digital range error latch
#29	Error status
#30	Identification code K2030
#31	Reserved

The FX2N-4AD-TC communicates with the PLC via buffer memories.

BFMs #21 to #27 and #31 are reserved.

All non reserved BFMs can be read by the PLC using the FROM instruction.

BFMs (buffer memories) marked with an "*" can be written to, the special function block using the TO instruction.

1) Buffer Memory BFM #0: Thermocouple Type K or J selection mode

BFM #0 is used to select Type K or J thermocouples for each channel. Each digit of a 4 digit hexadecimal number corresponds to one channel, the least significant digit being channel 1.

[Example]

H3310

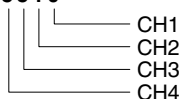

0 = K type
1 = J type
3 = Not used

- A/D conversion time is 240ms per channel. When "3" (unused) is set for a channel, A/D conversion is not executed for that channel, therefore, the total conversion time is decreased. In the above example, the conversion time is as follows:

$$\underline{240\text{ms (conversion time per channel)} \times 2\text{channels (number of channels used)} = 480\text{ms (total conversion time)}}$$

2) Buffer Memory BFMs #1 to #4: Number of temperature readings to be averaged

When the number of temperature readings to be averaged is specified for BFMs #1 to #4, the averaged data is stored in BFMs #5 to #8 (°C) and #13 to #16 (°F). Only the range 1 to 256 is valid for the number of temperature readings to be averaged. If a value outside of this range is entered, a default value of 8 is used.

3) Buffer Memory BFMs #9 to #12 and #17 to #20: Present temperature

These BFMs store the present value of the input data. This value is stored in units of 0.1°C or 0.1°F, but the resolution is only 0.4°C or 0.72°F for Type K and 0.3°C or 0.54°F for Type J.

6.2 Status Information

1) Buffer Memory BFM #28: Digital range error latch

BFM #29 b10(digital range error) is used to judge whether the measured temperature is within the unit's range.

BFM #28 latches the error status of each channel and can be used to check for thermocouple disconnection.

When an error occurs the temperature data before the error is latched. If the measured value returns to within valid limits the temperature data returns to normal operation. (Note: The error remains latched in (BFM #28))

An error can be cleared by writing K0 to BFM #28 using the TO instruction or turning off the power.

b15 or b8	b7	b6	b5	b4	b3	b2	b1	b0
Not used	High	Low	High	Low	High	Low	High	Low
	CH4		CH3		CH2		CH1	

Low : Latches ON when the temperature measurement data drops below the lowest temperature limit.

High : Turns ON when the temperature measurement data rises above the highest temperature limit, or when a thermocouple is disconnected.

[Handling for digital range error latch]

FX2N-4AD-TC has already started measuring operation when the PLC main unit's state becomes RUN after turning on the power.

If instability of the temperature value is expected because of noise just after turning on the power, reset the error once by writing 'K0' to BFM #28.

2) Buffer Memory BFM #29: Error status

Bit devices of BFM #29	ON	OFF
b0 : Error	When either b2 or b3 is ON A/D conversion is stopped for the error channel	No error
b1 : Not used	—	—
b2 : Power source	24V DC power supply failure	power supply normal
b3 : Hardware error	A/D converter or other hardware failure	Hardware Normal
b4 to b9 : Not used	—	—
b10 : Digital range error	Digital output/analog input value is outside the specified range.	Digital output value is normal.
b11 : Averaging number error	Selected number of averaged results is outside the available range -see BFM #1 to #4	Averaging is normal. (between 1 to 256)
b12 to b15 : Not used	—	—

3) Identification Code Buffer Memory BFM #30

The identification code or ID number for this Special Block is read from buffer memory BFM #30 using the FROM instruction. This number for the FX_{2N}-4AD-TC unit is K2030. The PLC can use this facility in its program to identify the special block before commencing data transfer to and from the special block.

7. SYSTEM BLOCK DIAGRAM

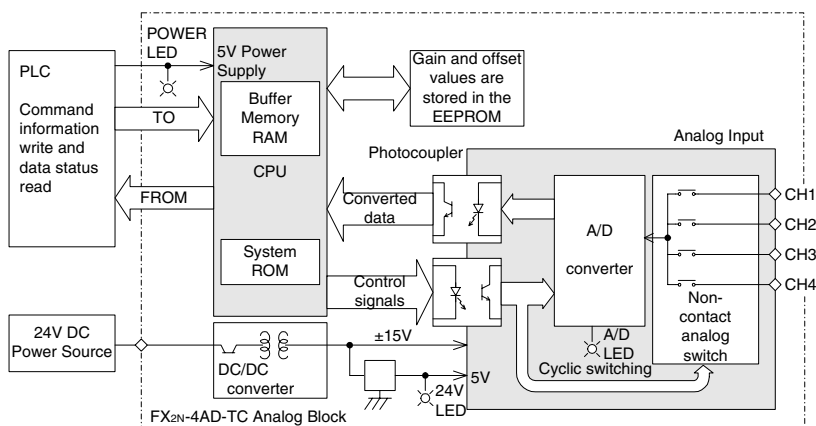

8. EXAMPLE PROGRAM

In the program shown below, the FX_{2N}-4AD-TC occupies the position of special block number 2 (that is the third closest block to the PLC). A Type K thermocouple is used on CH1 and a Type J on CH2. CH3 and CH4 are not used. The averaging count is four. The averaged values in degrees C of input channels CH1 and CH2 are stored respectively in data registers D0 and D1.

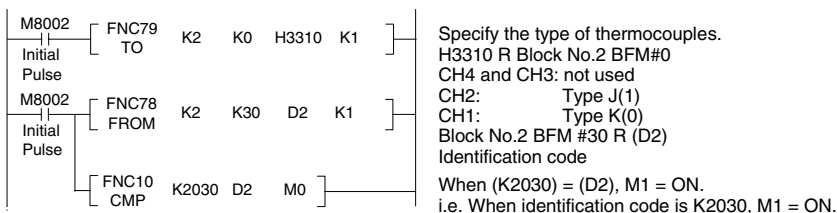

This initial step checks that the special function block placed at position 2 is actually an FX_{2N}-4AD-TC, i.e. its unit identification number is 2030 (BFM #30). This step is optional, but it provides a software check that the system has been configured correctly.

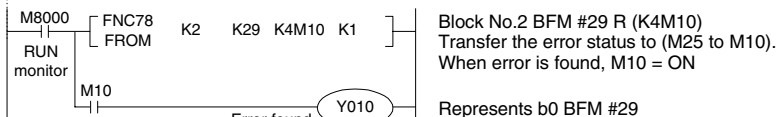

This step provides optional monitoring of the FX_{2N}-4AD-TC Error Buffer Memory (#29). If there is an Error on the FX_{2N}-4AD-TC, bit b0 of BFM #29 will be set on. This can be read by this program step, and output as a bit device in the PLC (Y010 in this example). Additional Error devices can be output in a similar manner, e.g. b10 BFM #29 Digital range error. (see below)

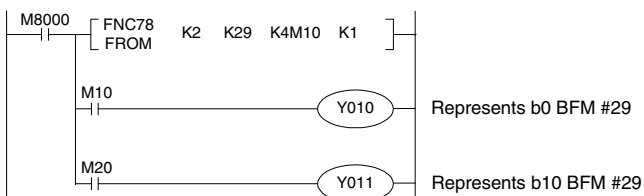

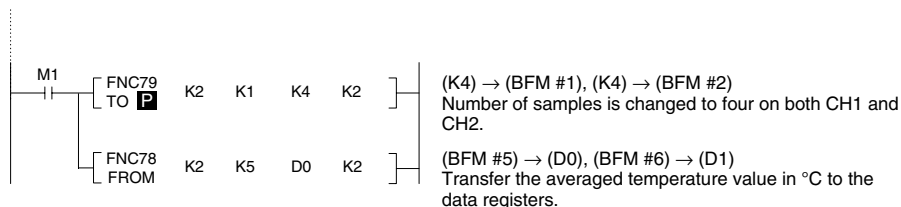

This step is the actual reading of the FX_{2N}-4AD-TC input channels. It is essentially the only program step which is needed. The "TO" instruction in this example, sets the input channels, CH1 and CH2, to take the average reading of four samples. The "FROM" instruction reads the average temperatures (BFM #5 and #6) for input channels CH1 and CH2 of the FX_{2N}-4AD-TC. If direct temperature readings are required BFM #9 and #10 should be read instead, e.g.

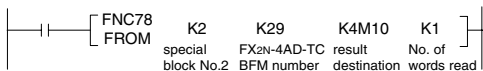

9. DIAGNOSTICS

9.1 Preliminary checks

- I. Check whether the input/output wiring and/or extension cables are properly connected on the FX_{2N}-4AD-TC analog special function block.
- II. Check that the PLC system configuration limits have not been exceeded, i.e. the number of special function blocks and the total system I/O are within the specified range.
- III. Ensure that the correct operating range has been selected for the application.
- IV. Check that there is no power overload on either the 5V or 24V power sources, remember the loading on the main unit or a powered extension unit varies according to the number of extension blocks or special function blocks connected.
- V. Make sure that the main unit has been switched to RUN.

9.2 Error checking

If the FX_{2N}-4AD-TC special function block does not seem to operate normally, check the following items.

- Check the status of the POWER LED.
Lit : The extension cable is properly connected.
Otherwise : Check the connection of the extension cable.
- Check the external wiring.
- Check the status of the "24V" LED (top right corner of the FX_{2N}-4AD-TC).
Lit : FX_{2N}-4AD-TC is ON, 24V DC power source is ON.
Otherwise : Possible 24V DC power failure, if ON possible FX_{2N}-4AD-TC failure.
- Check the status of the "A/D" LED (top right corner of the FX_{2N}-4AD-TC).
Lit : A/D conversion is proceeding normally.
Otherwise : Check buffer memory #29 (error status). If any bits (b0, b2, b3) are ON, then this is why the A/D LED is OFF.

10. EMC CONSIDERATIONS

Electromagnetic compatibility or EMC must be considered before using the FX_{2N}-4AD-TC.

Mitsubishi recommend that the thermocouple sensors used, should be fitted with a form of shield or screening as protection against EMC noise.

If some form of cable protection is used, the "Shield" must be terminated at the SLD ⊥ terminals as shown in chapter 2.

Because of the delicate nature of all analog signals, failure to take good EMC precautions could lead to EMC noise induced errors; up to ±10% of actual values. This is an absolute worst case figure, users who do take good precautions can expect operation within normal tolerances.

EMC considerations should include selection of good quality cables, good routing of those cables away from potential noise sources.

Additionally it is recommended that signal averaging is used as this will reduce the effects of random noise "spikes".

Manual number : JY992D65501

Manual revision : C

Date : JUNE 2005

MITSUBISHI ELECTRIC CORPORATION

HEAD OFFICE : MITSUBISHI DENKI BLDG MARUNOUTI TOKYO 100-8310
HIMEJI WORKS : 840, CHIYODA CHO, HIMEJI, JAPAN

FX_{2N}

FX_{2N}-4AD-TC SPECIAL FUNCTION BLOCK

USER'S GUIDE

JY992D65501C

This manual contains text, diagrams and explanations which will guide the reader in the correct installation and operation of the FX_{2N}-4AD-TC special function block and should be read and understood before attempting to install or use the unit.

Further information can be found in the FX PROGRAMMING MANUAL(II) and FX_{0N}/FX_{1N}/FX_{2N}/FX_{2NC} SERIES HARDWARE MANUAL.

Guidelines for the Safety of the User and Protection of the FX_{2N}-4AD-TC special function block.

This manual should be used by trained and competent personnel. The definition of such a person or persons is as follows:

- Any engineer using the product associated with this manual, should be of a competent nature, trained and qualified to the local and national standards. These engineers should be fully aware of all aspects of safety with regards to automated equipment.
- Any commissioning or service engineer must be of a competent nature, trained and qualified to the local and national standards.
- All operators of the completed equipment should be trained to use this product in a safe and coordinated manner in compliance to established safety practices.

Note: The term 'completed equipment' refers to a third party constructed device which contains or uses the product associated with this manual.

Notes on the Symbols Used in this Manual

At various times throughout this manual certain symbols will be used to highlight points of information which are intended to ensure the users personal safety and protect the integrity of equipment.



- Indicates that the identified danger **WILL** cause physical and property damage.



- Indicates that the identified danger could **POSSIBLY** cause physical and property damage.

- Under no circumstances will Mitsubishi Electric be liable or responsible for any consequential damage that may arise as a result of the installation or use of this equipment.
- All examples and diagrams shown in this manual are intended only as an aid to understanding the text, not to guarantee operation. Mitsubishi Electric will accept no responsibility for the actual use of the product based on these illustrative examples.
- Owing to the very great variety in possible applications for this equipment, you must satisfy yourself as to its suitability for your own specific application.

1. INTRODUCTION

- The FX_{2N}-4AD-TC analog block amplifies the signal from four thermocouple sensors (Type K or J) and converts the data into 12 bit reading's stored in the main unit. Both Centigrade (°C) and Fahrenheit (°F) can be read. Reading resolution is 0.4°C/0.72°F of Type K and 0.3°C/0.54°F of Type J.
- The FX_{2N}-4AD-TC can connected to the FX_{0N}, FX_{1N}, FX_{2N} and the FX_{2NC} series Programmable Controllers (PLC).
- All data transfers and parameter settings are adjusted via software control of the FX_{2N}-4AD-TC; by use of the TO/FROM applied instructions in the PLC.
- The FX_{2N}-4AD-TC occupies 8 I/O points on the PLC expansion bus. The 8 I/O points can be allocated from either inputs or outputs. The FX_{2N}-4AD-TC draws 40mA from the 5V rail of the main unit or powered extension unit.
- Thermocouples with the following specifications can be used: Type K (JIS 1602-1981) Type J (JIS 1602-1981)

2. EXTERNAL DIMENSIONS

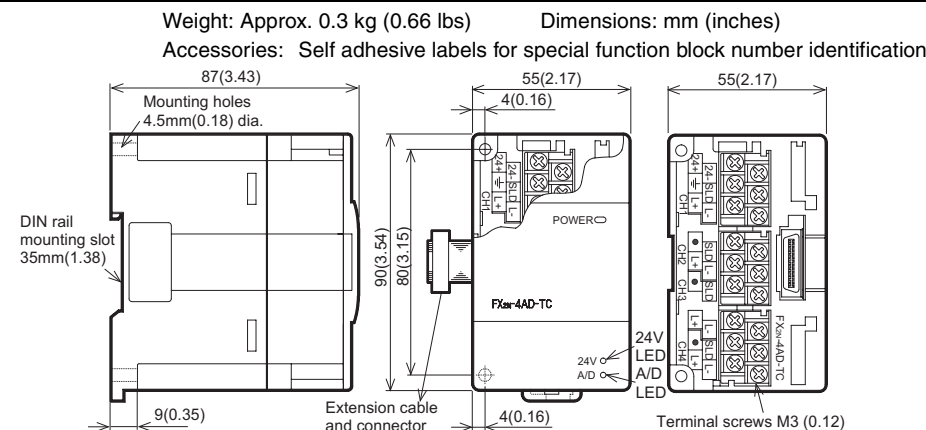

3. CONNECTION WITH PLC

3.1 Connection with PLC

- Up to 4 FX_{2N}-4AD-TC units can connect to the FX_{0N} series PLC, up to 5 for FX_{1N}, up to 8 for FX_{2N} or, up to 4 for an FX_{2NC} series PLC, all with powered extension units. However the following limitation exists when the undermentioned special function blocks are connected.

FX_{2N}: Main unit and powered extension units of 32 I/O points or less. Current consumption available for the undermentioned special function blocks ≤ 190mA

FX_{2N}: Main unit and powered extension units of 48 I/O points or more. Current consumption available for the undermentioned special function blocks ≤ 300mA

FX_{2NC}: Up to 4 undermentioned special function blocks can be connected regardless of the system I/O. When using an FX_{2NC} an FX_{2NC}-CNV-IF is required.

FX_{0N}/1N: Main unit and powered extension units. Up to 2 undermentioned special function blocks can be connected regardless of the system I/O.

- Each block occupies 8 I/O points (The 8 points can be allocated from either inputs or outputs).
- FX_{2N}-4AD-TC consumes 40mA from the 5V DC bus. The total 5V consumption of all special function blocks connected to a main unit or extension unit must not exceed the 5V source capacity of the system.
- The FX_{2N}-4AD-TC and main unit are connected by a cable on the right of the main unit.

3.2 Special function block numbers

Other special units of blocks that use FROM/TO commands, such as analog input blocks, analog output blocks and high-speed counter blocks, can be directly connected to the main unit of the PLC or to the right side of other extension blocks or units.

Connection example

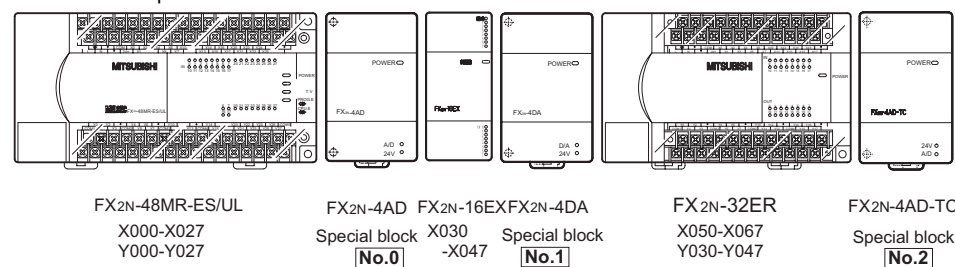

4. WIRING

4.1 Wiring

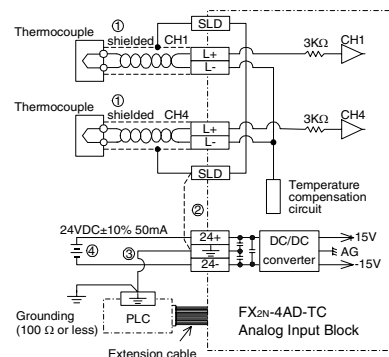

*1: The compensating cables that can be used for connecting with the thermocouple are the following. Type K: KX-G, KX-GS, KX-H, KX-HS, WX-G, WX-H, VX-G Type J: JX-G, JX-H For every 10Ω of line resistance, the compensating cable will indicate a temperature 0.12°C higher than actual. Check the line resistance before using. Long compensating cables are more prone to noise interference, therefore a short (less than 100m) compensating cable is recommended. Unused channels should have a wire link connected between the + and - terminals to prevent an errors being detected on that channel.

*2: If there is excessive electrical noise, connect the SLD terminal to the ground terminal on the unit.

*3: Connect the ground terminals of the FX_{2N}-4AD-TC unit and the main unit. Use grounding on the main unit.

*4: The 24V DC built-in supply of the PLC may be used as the power supply.

4.2 Using crimp terminations

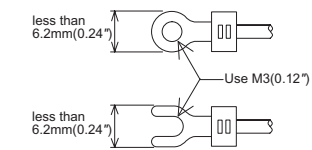

- Use crimp terminals as indicated on the left.
- Secure the terminal using a tightening torque of between 5 and 8 kg.cm.
- Wire only to the module terminals discussed in this manual. Leave all others vacant.

5. SPECIFICATIONS

5.1 Environmental specification

Item	Specification
Environmental specifications	Same as those for the main unit
Dielectric withstand voltage	500V AC, 1min (between all terminals and ground)

5.2 Power supply specification

Item	Specification
Analog circuits	24V DC ± 10%, 60mA
Digital circuits	5V DC, 40mA (internal power supply from the main unit)

5.3 Performance specification

Analog Inputs

Item	Centigrade (°C)		Fahrenheit (°F)	
	Both °C and °F are available by reading the appropriate buffer memory (BFM).			
Input signal	Thermocouple: Type K or J (either can be used for each channel), 4 channels, JIS 1602-1981			
Rated temperature range	Type K	-100°C to +1,200°C	Type K	-148°F to +2,192°F
	Type J	-100°C to +600°C	Type J	-148°F to +1,112°F
Digital output	12 bit conversion stored in 16 bit 2's complement form			
	Type K	-1,000 to 12,000	Type K	-148°F to +2,192°F
Resolution	Type K	0.4°C	Type K	0.72°F
	Type J	0.3°C	Type J	0.54°F
Overall accuracy	± (0.5% full scale +1°C)			
Calibration point	Freezing point of pure water 0°C / 32°F			
Conversion speed	(240ms ± 2%) × 4 channels (unused channels are not converted)			

Item	Centigrade (°C)	Fahrenheit (°F)
Conversion Characteristics		
Readings given at calibration reference point 0°C/32°F (0/320) respectively. (subject to the overall accuracy)	(Type K) +12,000	(Type K) +21,920
	(Type J) +6,000	(Type J) +11,120
	(Type J) -1,000	(Type J) -1,480
	(Type J) +600°C (Type J)	(Type J) +1,112°F (Type J)
	(Type K) +1,200°C (Type K)	(Type K) +2,192°F (Type K)

Miscellaneous

Item	Specification
Isolation	Photo-coupler isolation between analog and digital circuits. DC/DC converter isolation of power from main unit. No isolation between analog channels.
Number of occupied I/O points	The block occupies 8 I/O points (can be either inputs or outputs)

Note: Earth-tipped thermocouples are not suitable for use with this unit.

5.4 Installation location

This unit measures temperature according to the temperature difference between the temperature measurement part (thermocouple) and the terminal block. If this unit is installed at a place where the temperature of the terminal block varies rapidly, a measuring error may occur. For this reason, the unit should be installed at a place free from excessive temperature variation.

