

# MITSUBISHI

Mitsubishi Programmable Controller

MELSEC *L*series

---

## MELSEC-L Digital-Analog Converter Module User's Manual

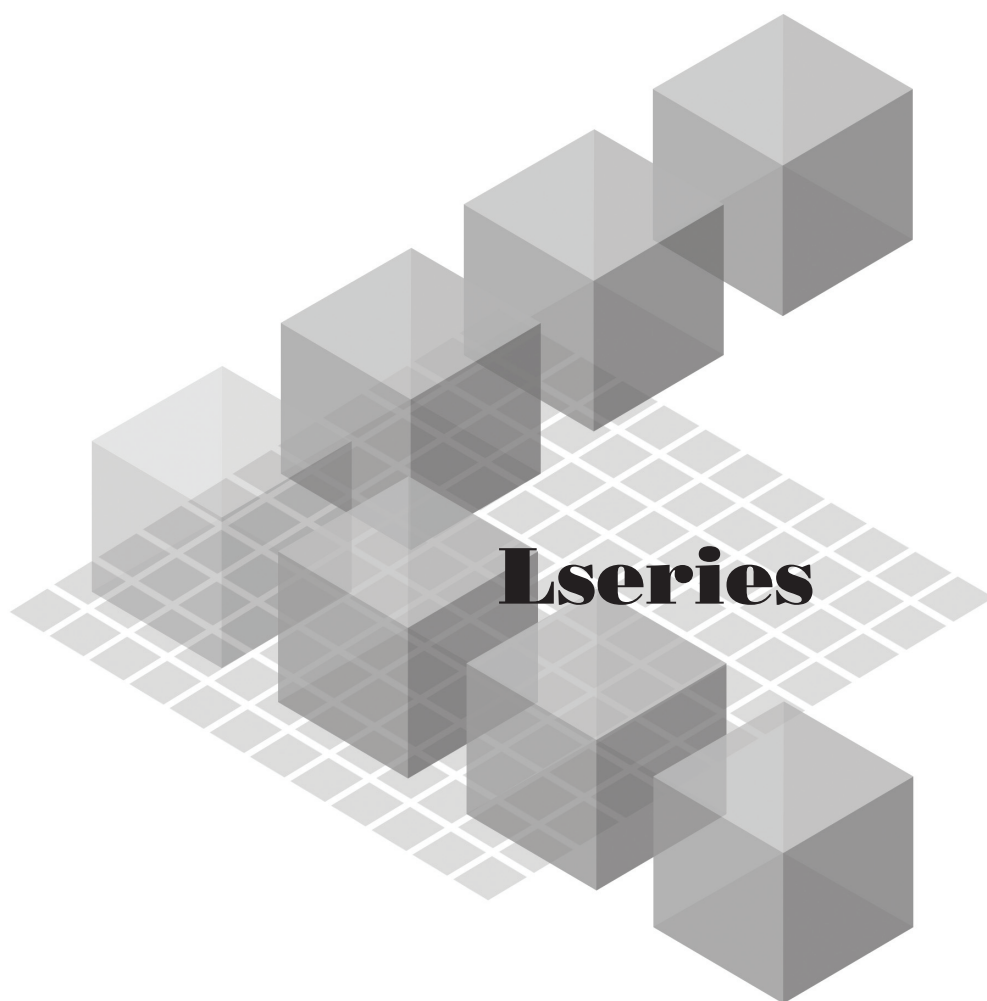

-L60DA4

MODEL



# ● SAFETY PRECAUTIONS ●

(Read these precautions before using this product.)

Before using this product, please read this manual and the relevant manuals carefully and pay full attention to safety to handle the product correctly.

The precautions given in this manual are concerned with this product only. For the safety precautions of the programmable controller system, refer to the user's manual for the CPU module used.

In this manual, the safety precautions are classified into two levels: "⚠ WARNING" and "⚠ CAUTION".



Indicates that incorrect handling may cause hazardous conditions, resulting in death or severe injury.



Indicates that incorrect handling may cause hazardous conditions, resulting in minor or moderate injury or property damage.

Under some circumstances, failure to observe the precautions given under "⚠ CAUTION" may lead to serious consequences.

Observe the precautions of both levels because they are important for personal and system safety.

Make sure that the end users read this manual and then keep the manual in a safe place for future reference.

## [Design Precautions]

### ⚠ WARNING

- Analog outputs may remain on due to a failure of the module. Configure an external interlock circuit for output signals that could cause a serious accident.
- Do not write any data to the "system area" and "write-protect area" (R) of the buffer memory in the intelligent function module.  
Also, do not use any "use prohibited" signals as an output signal from the programmable controller CPU to the intelligent function module.  
Doing so may cause malfunction of the programmable controller system.

## [Design Precautions]

### ⚠ CAUTION

- Do not install the control lines or communication cables together with the main circuit lines or power cables.  
Keep a distance of 100mm or more between them. Failure to do so may result in malfunction due to noise.
- At power-on, a voltage may occur or a current may flow between output terminals for a moment. In this case, start the control after analog outputs become stable.
- Power on or off the external power supply while the programmable controller is on. Failure to do so may result in incorrect output or malfunction.

## [Installation Precautions]

### **WARNING**

- Shut off the external power supply for the system in all phases before connecting or removing a module. Failure to do so may result in electric shock or cause the module to fail or malfunction.

## [Installation Precautions]

### **CAUTION**

- Use the programmable controller in an environment that meets the general specifications in the manual "Safety Guidelines", the manual supplied with the CPU module or head module. Failure to do so may result in electric shock, fire, malfunction, or damage to or deterioration of the product.
- To interconnect modules, engage the respective connectors and securely lock the module joint levers. Incorrect interconnection may cause malfunction, failure, or drop of the module.
- Tighten the screw within the specified torque range.  
Undertightening can cause drop of the screw, short circuit or malfunction.  
Overtightening can damage the screw and/or module, resulting in drop, short circuit, or malfunction.
- Do not directly touch any conductive parts and electronic components of the module. Doing so can cause malfunction or failure of the module.

## [Wiring Precautions]

### **WARNING**

- After installation and wiring, attach the included terminal cover to the module before turning it on for operation. Failure to do so may result in electric shock.

## [Wiring Precautions]

### **CAUTION**

- Ground the FG terminal to the protective ground conductor dedicated to the programmable controller. Failure to do so may result in electric shock or malfunction.
- Tighten the terminal block screw within the specified torque range. Undertightening can cause short circuit, fire, or malfunction.  
Overtightening can damage the screw and/or module, resulting in drop, short circuit, fire, or malfunction.
- Prevent foreign matter such as dust or wire chips from entering the module. Such foreign matter can cause a fire, failure, or malfunction.
- A protective film is attached to the top of the module to prevent foreign matter, such as wire chips, from entering the module during wiring. Do not remove the film during wiring. Remove it for heat dissipation before system operation.

## [Wiring Precautions]

### CAUTION

- Mitsubishi programmable controllers must be installed in control panels. Connect the main power supply to the power supply module in the control panel through a relay terminal block. Wiring and replacement of a power supply module must be performed by qualified maintenance personnel with knowledge of protection against electric shock. For wiring methods, refer to the MELSEC-L CPU Module User's Manual (Hardware Design, Maintenance and Inspection).

## [Startup and Maintenance Precautions]

### WARNING

- Do not touch any terminal while power is on. Doing so will cause electric shock or malfunction.
- Shut off the external power supply for the system in all phases before cleaning the module or retightening the terminal block screw. Failure to do so may result in electric shock.

## [Startup and Maintenance Precautions]

### CAUTION

- Do not disassemble or modify the module. Doing so may cause failure, malfunction, injury, or a fire.
- Shut off the external power supply for the system in all phases before connecting or removing a module. Failure to do so may cause the module to fail or malfunction.
- Tighten the terminal block screw within the specified torque range. Undertightening can cause drop of the component or wire, short circuit, or malfunction. Overtightening can damage the screw and/or module, resulting in drop, short circuit, or malfunction.
- After the first use of the product (module, display unit, and terminal block), the number of connections/disconnections is limited to 50 times (in accordance with IEC 61131-2). Exceeding the limit may cause malfunction.
- Before handling the module, touch a conducting object such as a grounded metal to discharge the static electricity from the human body. Failure to do so may cause the module to fail or malfunction.

## [Disposal Precautions]

### CAUTION

- When disposing of this product, treat it as industrial waste.

# ● CONDITIONS OF USE FOR THE PRODUCT ●

- (1) Mitsubishi programmable controller ("the PRODUCT") shall be used in conditions;
  - i) where any problem, fault or failure occurring in the PRODUCT, if any, shall not lead to any major or serious accident; and
  - ii) where the backup and fail-safe function are systematically or automatically provided outside of the PRODUCT for the case of any problem, fault or failure occurring in the PRODUCT.
  
- (2) The PRODUCT has been designed and manufactured for the purpose of being used in general industries.

MITSUBISHI SHALL HAVE NO RESPONSIBILITY OR LIABILITY (INCLUDING, BUT NOT LIMITED TO ANY AND ALL RESPONSIBILITY OR LIABILITY BASED ON CONTRACT, WARRANTY, TORT, PRODUCT LIABILITY) FOR ANY INJURY OR DEATH TO PERSONS OR LOSS OR DAMAGE TO PROPERTY CAUSED BY the PRODUCT THAT ARE OPERATED OR USED IN APPLICATION NOT INTENDED OR EXCLUDED BY INSTRUCTIONS, PRECAUTIONS, OR WARNING CONTAINED IN MITSUBISHI'S USER, INSTRUCTION AND/OR SAFETY MANUALS, TECHNICAL BULLETINS AND GUIDELINES FOR the PRODUCT.

("Prohibited Application")

Prohibited Applications include, but not limited to, the use of the PRODUCT in;

- Nuclear Power Plants and any other power plants operated by Power companies, and/or any other cases in which the public could be affected if any problem or fault occurs in the PRODUCT.
- Railway companies or Public service purposes, and/or any other cases in which establishment of a special quality assurance system is required by the Purchaser or End User.
- Aircraft or Aerospace, Medical applications, Train equipment, transport equipment such as Elevator and Escalator, Incineration and Fuel devices, Vehicles, Manned transportation, Equipment for Recreation and Amusement, and Safety devices, handling of Nuclear or Hazardous Materials or Chemicals, Mining and Drilling, and/or other applications where there is a significant risk of injury to the public or property.

Notwithstanding the above, restrictions Mitsubishi may in its sole discretion, authorize use of the PRODUCT in one or more of the Prohibited Applications, provided that the usage of the PRODUCT is limited only for the specific applications agreed to by Mitsubishi and provided further that no special quality assurance or fail-safe, redundant or other safety features which exceed the general specifications of the PRODUCTS are required. For details, please contact the Mitsubishi representative in your region.

# INTRODUCTION

---

Thank you for purchasing the Mitsubishi MELSEC-L series programmable controllers.

This manual describes the functions and programming of a digital-analog converter module (hereafter abbreviated as D/A converter module).

Before using this product, please read this manual and the relevant manuals carefully and develop familiarity with the functions and performance of the MELSEC-L series programmable controller to handle the product correctly.

When applying the program examples introduced in this manual to the actual system, ensure the applicability and confirm that it will not cause system control problems.

■Relevant module: L60DA4

## Remark

Unless otherwise specified, this manual describes the program examples in which the I/O numbers of X/Y00 to X/Y0F are assigned for a D/A converter module.

For I/O number assignment, refer to the following.

 MELSEC-L CPU Module User's Manual (Function Explanation, Program Fundamentals)

Operating procedures are explained using GX Works2. When using GX Developer or GX Configurator-DA, refer to the following.

- When using GX Developer or GX Configurator-DA ( Page 125, Appendix 8)

# COMPLIANCE WITH THE EMC AND LOW VOLTAGE DIRECTIVES

---

## **(1) For programmable controller system**

To configure a system meeting the requirements of the EMC and Low Voltage Directives when incorporating the Mitsubishi programmable controller (EMC and Low Voltage Directives compliant) into other machinery or equipment, refer to the manual "Safety Guidelines", the manual supplied with the CPU module or head module. The CE mark, indicating compliance with the EMC and Low Voltage Directives, is printed on the rating plate of the programmable controller.

## **(2) For the product**

No additional measures are necessary for the compliance of this product with the EMC and Low Voltage Directives.



# RELEVANT MANUALS

## (1) CPU module user's manual

Manual name <manual number (model code)>	Description
MELSEC-L CPU Module User's Manual (Hardware Design, Maintenance and Inspection) <SH-080890ENG, 13JZ36>	Specifications of the CPU modules, power supply modules, display unit, SD memory cards, and batteries, information on how to establish a system, maintenance and inspection, and troubleshooting
MELSEC-L CPU Module User's Manual (Function Explanation, Program Fundamentals) <SH-080889ENG, 13JZ35>	Functions and devices of the CPU module, and programming

## (2) Head module user's manual

Manual name <manual number (model code)>	Description
MELSEC-L CC-Link IE Field Network Head Module User's Manual <SH-080919ENG, 13JZ48>	Specifications for a head module, procedures before operation, system configuration, installation and wiring, settings, and troubleshooting
MELSEC-Q CC-Link IE Field Network Master/Local Module User's Manual <SH-080917ENG, 13JZ47>	Specifications for master/local module, procedures before operation, system configuration, installation, settings, functions, programming, and troubleshooting

## (3) Operating manual

Manual name <manual number (model code)>	Description
GX Works2 Version1 Operating Manual (Common) <SH-080779ENG, 13JU63>	System configuration, parameter settings, and online operations (common to Simple project and Structured project) of GX Works2
GX Developer Version 8 Operating Manual <SH-080373E, 13JU41>	Operating methods of GX Developer, such as programming, printing, monitoring, and debugging

# CONTENTS

SAFETY PRECAUTIONS .....	1
CONDITIONS OF USE FOR THE PRODUCT .....	4
INTRODUCTION .....	5
COMPLIANCE WITH THE EMC AND LOW VOLTAGE DIRECTIVES .....	6
RELEVANT MANUALS .....	7
MANUAL PAGE ORGANIZATION .....	11
TERMS .....	14
PACKING LIST .....	14
<hr/>	
<b>CHAPTER 1 D/A CONVERTER MODULE</b> .....	<b>15</b>
<hr/>	
1.1 Application .....	15
1.2 Features .....	16
<hr/>	
<b>CHAPTER 2 PART NAMES</b> .....	<b>17</b>
<hr/>	
<b>CHAPTER 3 SPECIFICATIONS</b> .....	<b>19</b>
<hr/>	
3.1 General Specifications .....	19
3.2 Performance Specifications .....	20
3.2.1 Number of parameter settings .....	21
3.3 Function List .....	22
3.4 I/O Signal List .....	23
3.5 Buffer Memory List .....	24
<hr/>	
<b>CHAPTER 4 PROCEDURES BEFORE STARTING THE OPERATION</b> .....	<b>29</b>
<hr/>	
<b>CHAPTER 5 SYSTEM CONFIGURATION</b> .....	<b>31</b>
<hr/>	
5.1 Overall System Configuration .....	31
5.2 Applicable System .....	32
5.3 Restrictions When D/A Converter Module is Connected to Head Module .....	32
<hr/>	
<b>CHAPTER 6 INSTALLATION AND WIRING</b> .....	<b>33</b>
<hr/>	
6.1 Installation Environment and Installation Position .....	33
6.2 Terminal Block .....	34
6.3 Wiring .....	36
6.4 External Wiring .....	37
<hr/>	
<b>CHAPTER 7 VARIOUS SETTINGS</b> .....	<b>38</b>
<hr/>	
7.1 Addition of Modules .....	38
7.2 Switch Setting .....	39
7.3 Parameter Setting .....	40
7.4 Auto Refresh .....	41
7.5 Offset/Gain Setting .....	42
7.5.1 Setting from GX Works2 "Offset/Gain Setting" .....	42
7.5.2 Setting from a program .....	45

---

**CHAPTER 8 FUNCTIONS** **49**

---

8.1	D/A Conversion Enable/Disable Function	49
8.2	D/A Output Enable/Disable Function	49
8.3	Analog Output HOLD/CLEAR Function	50
8.4	Analog Output Test when CPU Module is in STOP Status	52
8.5	Scaling Function	54
8.6	Alarm Output Function	59
8.7	Error Log Function	61
8.8	Module Error Collection Function	63
8.9	Error Clear Function	64
8.10	Saving and Restoring Offset/Gain Values	65

---

**CHAPTER 9 DISPLAY UNIT** **70**

---

9.1	Display Unit	70
9.2	Menu Structure	70
9.3	List of Setting Value Change Screens	72
9.4	Checking and Clearing Errors	75

---

**CHAPTER 10 PROGRAMMING** **77**

---

10.1	Procedure for Programming	77
10.2	When Using a Standard System Configuration	78
10.3	When D/A Converter Module is Connected to Head Module	83

---

**CHAPTER 11 TROUBLESHOOTING** **90**

---

11.1	Checking on the Module Detailed Information	91
11.2	Checking by Latest Error Code (Un\G19)	92
11.3	Checking on the Module Error Collection Function	92
11.4	Error Code List	93
11.5	Alarm Code List	94
11.6	Troubleshooting	95
11.7	Checking the Status of D/A Converter Module by the System Monitor	97

---

**APPENDICES** **98**

---

Appendix 1	Details of I/O Signals	98
Appendix 1.1	Input Signal	98
Appendix 1.2	Output Signal	102
Appendix 2	Details of Buffer Memory Addresses	104
Appendix 3	I/O Conversion Characteristic of D/A Conversion	112
Appendix 4	D/A Conversion Accuracy	114
Appendix 5	Dedicated Instruction	115
Appendix 5.1	Instruction List	115
Appendix 5.2	G(P).OFFGAN	116

Appendix 5.3 G(P).OGLOAD .....	118
Appendix 5.4 G(P).OGSTOR .....	121
Appendix 6 Checking Serial Number and Function Version .....	124
Appendix 7 Differences with Q Series .....	124
Appendix 8 When Using GX Developer or GX Configurator-DA .....	125
Appendix 8.1 Operation of GX Developer .....	125
Appendix 8.2 Operation of GX Configurator-DA .....	127
Appendix 9 External Dimensions .....	129

---

<b>INDEX</b>	<b>131</b>
--------------	------------

---

<b>INSTRUCTION INDEX</b>	<b>133</b>
--------------------------	------------

---

REVISIONS .....	134
Warranty .....	135

# MANUAL PAGE ORGANIZATION

In this manual, pages are organized and the symbols are used as shown below.

The following page illustration is for explanation purpose only, and is different from the actual pages.

Annotations for the manual page illustration:

- "" is used for screen names and items.
- 1. shows operating procedures.
- ☞ shows mouse operations.\*1
- [ ] is used for items in the menu bar and the project window.
- Ex. shows setting or operating examples.
- 📖 shows reference manuals.
- 👉 shows reference pages.

Page content annotations:

- CHAPTER 7 VARIOUS SETTINGS
- 7.1.1 Setting method
- (1) Setting parameters
- (a) Operating procedure
- 1. Open the "PLC Parameter" dialog box.
  - ☞ Project window -> [Parameter] -> [PLC parameter]
- 2. Select the "IO Assignment" tab.

Item	Description	Reference
Type	Select the type of the connected module.	Page 74, Section 7.1.2
Model Name	Select the model name of the connected module.	Page 74, Section 7.1.3
Points	Set the number of points assigned to each slot.	Page 74, Section 7.1.4
Start XY	Specify a start I/O number for each slot.	Page 74, Section 7.1.5
Switch Setting	Configure the switch setting of the built-in I/O or intelligent function modules.	Page 74, Section 7.1.6
Default Setting	Set the following: <ul style="list-style-type: none"> <li>• Error Time Output Mode</li> <li>• PLC Operation Mode at HW Error</li> <li>• I/O Response Time</li> </ul>	Page 75, Section 7.1.7

Setting "Start XY" enables modification on the start I/O numbers assigned to connected modules.

Ex. When "1000" is specified in "Start XY" to the slot where a 16-point module is connected, the assignment range of an input module is changed to X1000 to X100F.

For details, refer to the following.

📖 MELSEC-L CPU Module User's Manual (Function Explanation, Program Fundamentals)

**Point** ☞ Set the type of the connected module in "Type". Setting a different type results in "SPUNIT LAY ERR." For intelligent function module, the I/O points must also be the same in addition to the I/O assignment setting. (Page 30, Section 4.2.2)

**Remark** When an intelligent module is connected, I/O assignment can be omitted by selecting connected modules from "Intelligent Function Module" in the Project window.

73

\*1 The mouse operation example is provided below. (For GX Works2)

Annotations for the GX Works2 interface:

- Menu bar: Ex. ☞ [Online] ☞ [Write to PLC...]  
Select [Online] on the menu bar, and then select [Write to PLC...].
- A window selected in the view selection area is displayed. Ex. ☞ Project window ☞ [Parameter] ☞ [PLC Parameter]  
Select [Project] from the view selection area to open the Project window. In the Project window, expand [Parameter] and select [PLC Parameter].
- View selection area

Pages describing instructions are organized as shown below.

The following page illustrations are for explanation purpose only, and are different from the actual pages.

Instruction name

6.4.2 Disconnecting a connection (SP.SOCCLDSE)

Execution condition of the instruction

Structure of the instruction in the ladder mode

Shows the devices applicable to the instruction

Setting data	Internal device		JDIQ		UDIGI	Zn	Consta nt K, H	Others
	Bit	Word	Bit	Word				
⓪	—	○	○	—	—	—	○	—
⓪	—	△ <sup>1</sup>	△ <sup>1</sup>	—	—	—	—	—
⓪	—	△ <sup>1</sup>	△ <sup>1</sup>	—	—	—	—	—

\*1 File registers set for each local device or program cannot be used.

6

Descriptions of setting data and data type

(1) Setting data

Setting data	Description	Set by	Data type
UD	Dummy	—	Character string
⓪	Connection number (Setting range: 1 to 16)	User	BIN 16-bit
⓪	Start number of the device from which control data are stored	System	Device name
⓪	Start number of the device which turns on for one scan upon completion of the instruction ⓪+1 also turns on when failed.	System	Bit

Setting side  
User : Device value is set by the user.  
System: Device value is set by the CPU module.

Descriptions of control data (if any)

(2) Control data

Device	Item	Description	Setting range	Set by
⓪+0	System area	—	—	—
⓪+1	Completion status	Completion status is stored 0000< Completed Other than 0000< Failed (Error code)	—	System

63

Detailed descriptions of the instruction

(3) Function

This instruction closes a connection specified in ⓪. (Disconnection of a connection)  
The result of the SP.SOCCLDSE instruction can be checked with the completion device, ⓪ + 0 and ⓪ + 1.

- Completion device ⓪ + 0  
Turns on in the END processing of a scan after completion of the SP.SOCCLDSE instruction, and turns off in the next END processing.
- Completion device ⓪ + 1  
Turns on or off according to the result of the SP.SOCCLDSE instruction.

State	Description
When completed	Remains off.
When failed	Turns on in the END processing of a scan after completion of the SP.SOCCLDSE instruction, and turns off in the next END processing.

Conditions for the error and error codes  
For the errors not described in this manual, refer to the following.  
MELSEC-Q/L Programming Manual (Common Instruction)

(4) Error

A detection of an operation error turns on the Error flag (SM0) and a corresponding error code is stored in SD0 when:

- The connection number specified for ⓪ is other than 1 to 16. (Error code: 4101)
- The device numbers specified for ⓪ and ⓪ exceed the device point range. (Error code: 4101)
- An invalid device is specified. (Error code: 4004)

Simple program example(s) and descriptions of the devices used

(5) Program example

When M2000 is turned on or when the connected device disconnects connection No. 1, connection No. 1 is disconnected by the following program.

- Device used

Device number	Application
SD1282	Open completion signal
SD1284	Open request signal
D200	SP.SOCCLDSE instruction control data
M200	SP.SOCCLDSE instruction completion device





Program

```

SD1282 AND SD1284 AND M200 ---[SP.SOCCLDSE "UD" K1 D200 M200]
M200 ---[SET M210]
M210 ---[SET M202]
M202 ---[SET M203]
M203 ---[SET M210]
M210 ---[RST M210]
END
    
```

64

- Instructions can be executed under the following conditions.

Execution condition	Any time	During on	On the rising edge	During off	On the falling edge
Symbol	No symbol				

- The following devices can be used.

Setting data	Internal device (system, user)		File register	Link direct device J□□		Intelligent function module device U□\G□	Index register Zn	Constant *3	Others *3
	Bit	Word		Bit	Word				
Applicable device *1	X, Y, M, L, SM, F, B, SB, FX, FY*2	T, ST, C, D, W, SD, SW, FD, @□	R, ZR	—		U□\G□	Z	K, H, E, \$	P, I, J, U, D, X, DY, N, BL, TR, BLIS, V

\*1 For details on each device, refer to the following.

 MELSEC-L CPU Module User's Manual (Function Explanation, Program Fundamentals)

\*2 FX and FY can be used for bit data only, and FD for word data only.

\*3 In the "Constant" and "Others" columns, a device(s) that can be set for each instruction is shown.

- The following data types can be used.

Data type	Description
Bit	Bit data or the start number of bit data
BIN 16-bit	16-bit binary data or the start number of word device
BIN 32-bit	32-bit binary data or the start number of double-word device
BCD 4-digit	Four-digit binary-coded decimal data
BCD 8-digit	Eight-digit binary-coded decimal data
Real number	Floating-point data
Character string	Character string data
Device name	Device name data

# TERMS

Unless otherwise specified, this manual uses the following terms.

Term	Description
D/A converter module	Another term for the MELSEC-L series digital-analog converter module
Head module	Abbreviation for the LJ72GF15-T2 CC-Link IE field network head module
Display unit	A liquid crystal display to be attached to the CPU module
Programming tool	Generic term for GX Works2 and GX Developer
Factory default setting	Generic term for analog output ranges of 0 to 5V, 1 to 5V, -10 to 10V, 0 to 20mA, and 4 to 20mA
GX Works2	Product name of the software package for the MELSEC programmable controllers
GX Developer	
GX Configurator-DA	A setting and monitoring tool added in GX Developer (for D/A converter modules)
Buffer memory	The memory of an intelligent function module used to store data (such as setting values and monitored values) for communication with a CPU module.

# PACKING LIST

The following items are included in the package of this product. Before use, check that all the items are included.

## L60DA4

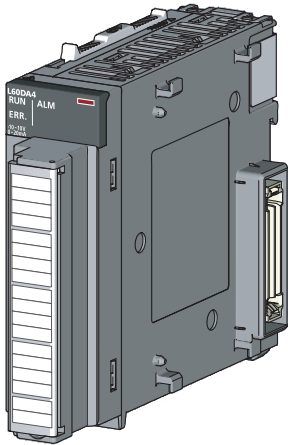

L60DA4

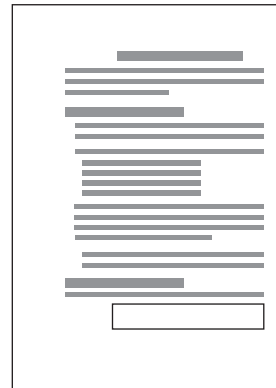

Before Using the Product



# CHAPTER 1 D/A CONVERTER MODULE

This chapter describes the application and features of the D/A converter module.

## 1.1 Application

This module converts the digital data received from the CPU module to the analog signal and outputs the signal to external devices. By converting the data, which has been processed through the CPU module, to an analog data, the input information can be sent to the devices including an inverter.

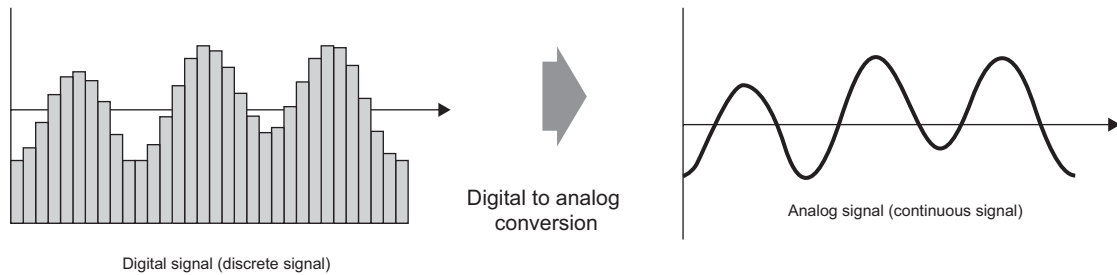

The D/A converter module enables works as follows.

Connect the module to the control valve to control the flow to a tank.

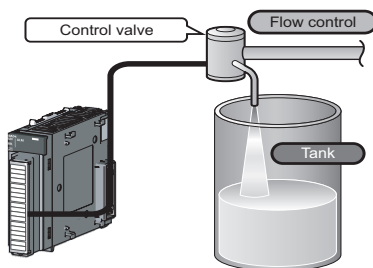

Connect the module to an inverter to control the conveyer belt speed.

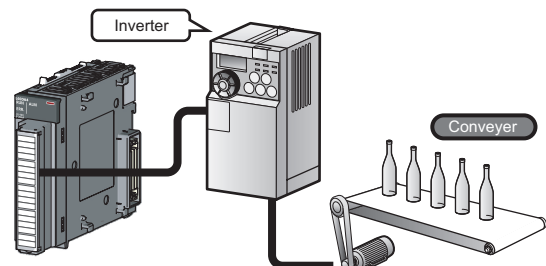

Connect the module to the power conditioning equipment to control the heating temperature of a heater or others.

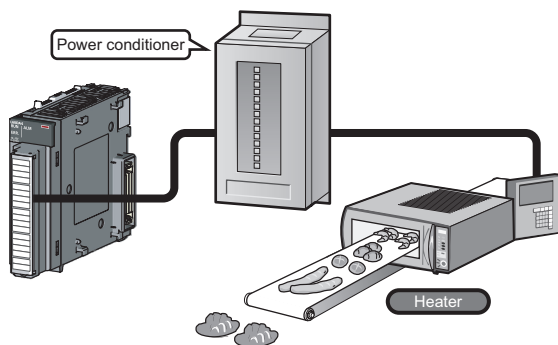

## 1.2 Features

---

### (1) Improved response by high-speed conversion

The high-speed conversion speed of 20 $\mu$ s/channel is achieved.

### (2) Detailed control by high resolution

In all analog output ranges, the high resolution of 1/20000 is achieved.

### (3) Reliability by high accuracy

The accuracy for the maximum value of analog output value is  $\pm 0.1\%$  ( $25 \pm 5^\circ\text{C}$ ) and  $\pm 0.3\%$  (0 to  $55^\circ\text{C}$ ).

### (4) Scaling function

This function converts a digital value to the ratio value (%) in any width to represent the digital value in a numeric value easy to understand.

### (5) Error detection and monitoring

When the digital value exceeds the specified range, the module detects an alarm so that the digital value error monitoring and the output control are enabled.

# CHAPTER 2 PART NAMES

The following table shows the part names of the D/A converter module.

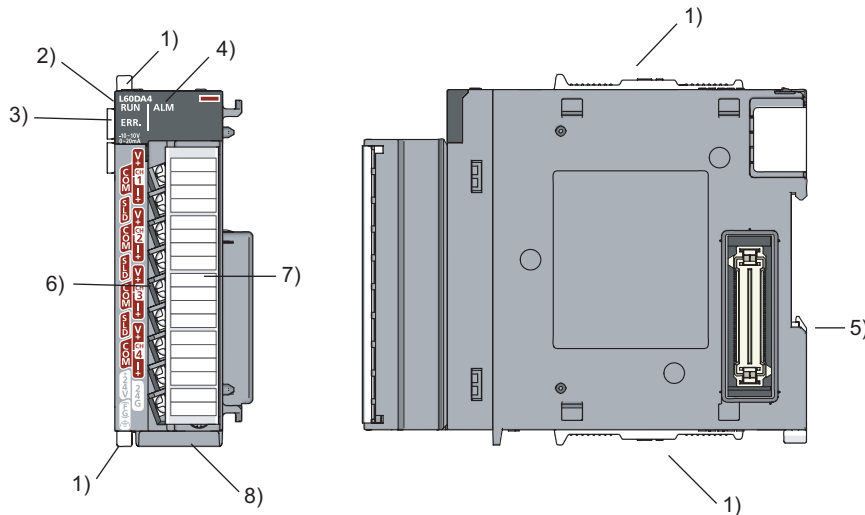

Number	Name	Description
1)	Module joint levers	Levers for connecting two modules
2)	RUN LED (green)	Displays the operating status of the D/A converter module. On: The module is operating normally. Flashing: In the offset/gain setting mode Off: The 5V power off or watchdog timer error has occurred.
3)	ERR. LED (red)	Displays the errors and status of the D/A converter module. On: an error has occurred except for error code: 112* <sup>1</sup> Flashing: Error code: 112 has occurred.* <sup>1</sup> Off : during normal operation
4)	ALM LED (red)	Displays the alarm status of the D/A converter module. On: Alarm output is occurring* <sup>2</sup> Off: The module is operating normally.* <sup>2</sup>
5)	DIN rail hook	A hook used to mount the module to a DIN rail
6)	Terminal block	18-pin screw terminal block for connecting output signal lines of such as external devices
7)	Terminal block cover	Cover for preventing electric shock while the power is on.
8)	Serial number display	Displays the serial number printed on the rating plate.

\*1 Error Code List (☞ Page 93, Section 11.4)

\*2 Alarm Code List (☞ Page 94, Section 11.5)

# Memo

---

# CHAPTER 3 SPECIFICATIONS

---

This chapter describes general specifications, performance specifications, function list, list of I/O signals, and list of buffer memory addresses.

## 3.1 General Specifications

---

**3**

For the general specifications of the D/A converter module, refer to the following.

 The manual "Safety Guidelines", the manual supplied with the CPU module or head module

## 3.2 Performance Specifications

The following table shows the performance specifications of the D/A converter module.

Item		Model				
		L60DA4				
Number of analog output points		4 points (4 channels)				
Digital input		-20480 to 20479				
		When using the scaling function -32768 to 32767				
Analog output		Voltage -10 to 10 VDC (external load resistance 1kΩ to 1MΩ)				
		Current 0 to 20 mADC (external load resistance 0Ω to 600Ω)				
I/O characteristics, resolution		Analog output range		Digital value	Resolution	
		Voltage	0 to 5V		0 to 20000	250μV
			1 to 5V			200μV
			-10 to 10V		-20000 to 20000	500μV
			User range setting			333μV <sup>*1</sup>
		Current	0 to 20mA		0 to 20000	1000nA
			4 to 20mA			800nA
			User range setting		-20000 to 20000	700nA <sup>*1</sup>
Accuracy (accuracy for the maximum value of analog output value) <sup>*2</sup>	Ambient temperature 25±5°C	Within ±0.1% (voltage: ±10mV, current: ±20μA)				
	Ambient temperature 0 to 55°C	Within ±0.3% (voltage: ±30mV, current: ±60μA)				
Conversion speed		20μs/channel				
Offset/gain setting count		Up to 50000 counts				
Output short protection		Protected				
Isolation method		Between I/O terminals and programmable controller power supply: photocoupler isolation Between output channels: no isolation Between external power supply and analog output: transformer isolation				
Dielectric withstand voltage		Between I/O terminals and programmable controller power supply: 500VACrms for 1 minute Between external power supply and analog output: 500VACrms for 1 minute				
Insulation resistance		Between I/O terminals and programmable controller power supply: 500VDC 10MΩ or higher				
Number of occupied I/O points		16 points (I/O assignment: Intelligent 16 points)				
Connected terminal		18-point terminal block				
Applicable wire size		0.3 to 0.75mm <sup>2</sup>				
Applicable solderless terminal		R1.25 to 3 (solderless terminals with sleeve are not usable)				
External supply power		24VDC +20%, -15%				
		Ripple, spike 500mV <sub>P-P</sub> or lower				
		Inrush current: 4.3A, 1000μs or shorter				
		Current consumption: 0.18A				
Internal current consumption (5VDC)		0.16A				
Weight		0.20kg				

\*1 Maximum resolution in the user range setting.

\*2 Except when receiving noise influence.

Warm up (or power on) the module for 30 minutes to satisfy the accuracy shown in the table.

## 3.2.1 Number of parameter settings

Set the initial setting of D/A converter module and the parameter setting of auto refresh setting so that the number of parameters, including these of other intelligent function modules, does not exceed the number of parameters that can be set in the CPU module or the head module.

For the maximum number of parameters that can be set in the CPU module or the head module (maximum number of parameter settings), refer to the following.

 MELSEC-L CPU Module User's Manual (Hardware Design, Maintenance and Inspection)

 MELSEC-L CC-Link IE Field Network Head Module User's Manual

### (1) Number of the D/A converter module parameters

For D/A converter modules, the following number of parameters can be set per module.

Target module	Initial setting	Auto refresh setting
L60DA4	4	11 (maximum number of settings)

### (2) Checking method

The maximum number of parameter settings and the number of parameter settings set for the intelligent function module can be checked with the following operation.

-  Project window ⇒ [Intelligent Function Module] ⇒ Right-click
- ⇒ [Intelligent Function Module Parameter List]

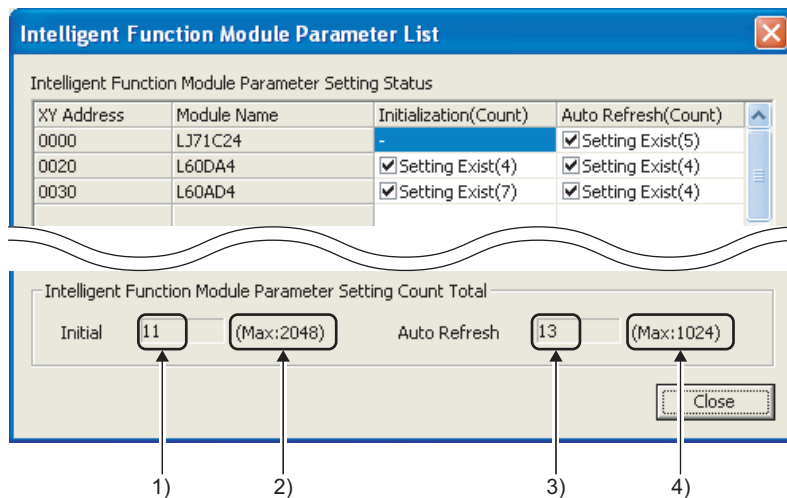

No.	Description
1)	The total number of parameters in the initial settings selected on the dialog box
2)	The maximum number of parameter settings in the initial settings
3)	The total number of parameters in the auto refresh settings selected on the dialog box
4)	The maximum number of parameter settings in the auto refresh settings

## 3.3 Function List

The following shows the function list of the D/A converter module.

Item	Description	Reference
D/A conversion enable/disable function	Sets whether to enable or disable D/A conversion for each channel. Disabling the D/A conversion for unused channels reduces the conversion cycles.	Page 49, Section 8.1
D/A output enable/disable function	This function sets whether to output the D/A conversion value or the offset value, for each channel. The conversion speed is constant, regardless of the output enable/disable status.	Page 49, Section 8.2
Range switching function	The output range to use can be selected from the factory default range (4mA to 20mA, 0mA to 20mA, 1V to 5V, 0V to 5V or -10V to 10V) and user range (user range setting).	Page 39, Section 7.2
Offset/gain setting function	This function compensates for errors in analog output values.	Page 42, Section 7.5
Analog output HOLD/CLEAR function	This function sets whether to hold the output analog value (HOLD) or clear the output analog value (CLEAR), according to the CPU module operating status (RUN, STOP or stop error).	Page 50, Section 8.3
Analog output test when CPU module is in STOP status	When the CPU module is in STOP operation status, forcibly turning CH□ Output enable/disable flag (Y1 to Y4) ON outputs the D/A-converted analog value.	Page 52, Section 8.4
Scaling function	This function performs a scale conversion of the digital value that was input into a digital value between -20000 and 20000 (or 0 and 20000) using any given set scaling upper or lower limit value, and outputs the corresponding analog value.	Page 54, Section 8.5
Alarm output function	This function outputs an alarm when the digital value is outside the preset range.	Page 59, Section 8.6
External power supply READY flag (X7)	This signal turns ON when the external power supply 24VDC is supplied. When the flag is OFF, 0V/0mA are output to analog output values regardless of other settings.	Page 98, Appendix 1.1(2)
Error log function	This function stores up to 16 errors and alarms that occur on the D/A converter module to the buffer memory as history.	Page 61, Section 8.7
Module error collection	This function collects errors and alarms occurred in the D/A converter module and stores to the CPU module or the head module.	Page 63, Section 8.8
Error clear function	Clearing the error from the system monitor at error occurrence is possible.	Page 64, Section 8.9
Save/restoration of offset/gain value	The offset/gain value of the user range setting can be saved or restored.	Page 65, Section 8.10



## 3.4 I/O Signal List

The following shows the I/O signal list of the D/A converter module.

For details on the setting status, refer to the following.

- Details of I/O signals (☞ Page 98, Appendix 1)

Input signal		Output signal	
Device number	Signal name	Device number	Signal name
X0	Module READY	Y0	Use prohibited
X1	Use prohibited	Y1	CH1 Output enable/disable flag
X2		Y2	CH2 Output enable/disable flag
X3		Y3	CH3 Output enable/disable flag
X4		Y4	CH4 Output enable/disable flag
X5		Y5	Use prohibited
X6		Y6	
X7	External power supply READY flag	Y7	Use prohibited
X8	Use prohibited	Y8	
X9	Operating condition setting completed flag	Y9	Operating condition setting request
XA	Offset/gain setting mode flag	YA	User range writing request
XB	Channel change completed flag	YB	Channel change request
XC	Set value change completed flag	YC	Set value change request
XD	Use prohibited	YD	Use prohibited
XE	Warning output signal	YE	Warning output clear request
XF	Error flag	YF	Error clear request

### Point

The I/O number (X/Y) described above shows the case that the start I/O number of the D/A converter module is set to "0".

## 3.5 Buffer Memory List

The following shows the buffer memory list of the D/A converter module.

For details on buffer memory, refer to the following.

- Detail of buffer memory (☞ Page 104, Appendix 2)

### Point

Do not write data to the system area and the area where the data cannot be written from the program in buffer memory. Writing data to these areas may lead the module to malfunction.

#### (1) Un\G0 to Un\G1799

Address (decimal)	Address (hexadecimal)	Name	Default *1	Read/Write *2
0	0 <sub>H</sub>	D/A conversion enable/disable setting	000F <sub>H</sub>	R/W
1	1 <sub>H</sub>	CH1 Digital value	0	R/W
2	2 <sub>H</sub>	CH2 Digital value	0	R/W
3	3 <sub>H</sub>	CH3 Digital value	0	R/W
4	4 <sub>H</sub>	CH4 Digital value	0	R/W
5 to 10	5 <sub>H</sub> to A <sub>H</sub>	System area	—	—
11	B <sub>H</sub>	CH1 Set value check code	0000 <sub>H</sub>	R
12	C <sub>H</sub>	CH2 Set value check code	0000 <sub>H</sub>	R
13	D <sub>H</sub>	CH3 Set value check code	0000 <sub>H</sub>	R
14	E <sub>H</sub>	CH4 Set value check code	0000 <sub>H</sub>	R
15 to 18	F <sub>H</sub> to 12 <sub>H</sub>	System area	—	—
19	13 <sub>H</sub>	Latest error code	0	R
20	14 <sub>H</sub>	Setting range	0000 <sub>H</sub>	R
21	15 <sub>H</sub>	System area	—	—
22	16 <sub>H</sub>	Offset/gain setting mode Offset specification	0000 <sub>H</sub>	R/W
23	17 <sub>H</sub>	Offset/gain setting mode Gain specification	0000 <sub>H</sub>	R/W
24	18 <sub>H</sub>	Offset/gain adjustment value specification	0	R/W
25	19 <sub>H</sub>	System area	—	—
26	1A <sub>H</sub>	HOLD/CLEAR function setting	0000 <sub>H</sub>	R
27 to 46	1B <sub>H</sub> to 2E <sub>H</sub>	System area	—	—
47	2F <sub>H</sub>	Warning output setting	000F <sub>H</sub>	R/W
48	30 <sub>H</sub>	Warning output flag	0000 <sub>H</sub>	R

Address (decimal)	Address (hexadecimal)	Name	Default *1	Read/Write *2
49 to 52	31 <sub>H</sub> to 34 <sub>H</sub>	System area	—	—
53	35 <sub>H</sub>	Scaling enable/disable setting	000F <sub>H</sub>	R/W
54	36 <sub>H</sub>	CH1 Scaling lower limit value	0	R/W
55	37 <sub>H</sub>	CH1 Scaling upper limit value	0	R/W
56	38 <sub>H</sub>	CH2 Scaling lower limit value	0	R/W
57	39 <sub>H</sub>	CH2 Scaling upper limit value	0	R/W
58	3A <sub>H</sub>	CH3 Scaling lower limit value	0	R/W
59	3B <sub>H</sub>	CH3 Scaling upper limit value	0	R/W
60	3C <sub>H</sub>	CH4 Scaling lower limit value	0	R/W
61	3D <sub>H</sub>	CH4 Scaling upper limit value	0	R/W
62 to 85	3E <sub>H</sub> to 55 <sub>H</sub>	System area	—	—
86	56 <sub>H</sub>	CH1 Warning output upper limit value	0	R/W
87	57 <sub>H</sub>	CH1 Warning output lower limit value	0	R/W
88	58 <sub>H</sub>	CH2 Warning output upper limit value	0	R/W
89	59 <sub>H</sub>	CH2 Warning output lower limit value	0	R/W
90	5A <sub>H</sub>	CH3 Warning output upper limit value	0	R/W
91	5B <sub>H</sub>	CH3 Warning output lower limit value	0	R/W
92	5C <sub>H</sub>	CH4 Warning output upper limit value	0	R/W
93	5D <sub>H</sub>	CH4 Warning output lower limit value	0	R/W
94 to 157	5E <sub>H</sub> to 9D <sub>H</sub>	System area	—	—
158	9E <sub>H</sub>	Mode switching setting	0	R/W
159	9F <sub>H</sub>		0	R/W
160 to 199	A0 <sub>H</sub> to C7 <sub>H</sub>	System area	—	—
200	C8 <sub>H</sub>	Pass data classification setting	0	R/W
201	C9 <sub>H</sub>	System area	—	—
202	CA <sub>H</sub>	CH1 Industrial shipment settings offset value	0	R/W
203	CB <sub>H</sub>	CH1 Industrial shipment settings gain value	0	R/W
204	CC <sub>H</sub>	CH2 Industrial shipment settings offset value	0	R/W
205	CD <sub>H</sub>	CH2 Industrial shipment settings gain value	0	R/W
206	CE <sub>H</sub>	CH3 Industrial shipment settings offset value	0	R/W
207	CF <sub>H</sub>	CH3 Industrial shipment settings gain value	0	R/W
208	D0 <sub>H</sub>	CH4 Industrial shipment settings offset value	0	R/W
209	D1 <sub>H</sub>	CH4 Industrial shipment settings gain value	0	R/W
210	D2 <sub>H</sub>	CH1 User range settings offset value	0	R/W

Address (decimal)	Address (hexadecimal)	Name	Default *1	Read/Write *2
211	D3 <sub>H</sub>	CH1 User range settings gain value	0	R/W
212	D4 <sub>H</sub>	CH2 User range settings offset value	0	R/W
213	D5 <sub>H</sub>	CH2 User range settings gain value	0	R/W
214	D6 <sub>H</sub>	CH3 User range settings offset value	0	R/W
215	D7 <sub>H</sub>	CH3 User range settings gain value	0	R/W
216	D8 <sub>H</sub>	CH4 User range settings offset value	0	R/W
217	D9 <sub>H</sub>	CH4 User range settings gain value	0	R/W
218 to 1799	DA <sub>H</sub> to 707 <sub>H</sub>	System area	—	—

\*1 The default value is a value set after power-on or after resetting the CPU module.

\*2 This shows whether reading the data from or writing the data to the area with programs is possible.

R: Readable

W: Writable

**(2) Error history (Un\G1800 to Un\G1969)**

Address (decimal)	Address (hexadecimal)	Name			Default *1	Read/Write *2	
1800	708 <sub>H</sub>	Latest error code address			0	R	
1801 to 1809	709 <sub>H</sub> to 711 <sub>H</sub>	System area			—	—	
1810	712 <sub>H</sub>	No. 1	Error code		0	R	
1811	713 <sub>H</sub>		Error time	First two digits of the year	Last two digits of the year	0	R
1812	714 <sub>H</sub>			Month	Day	0	R
1813	715 <sub>H</sub>			Hour	Minute	0	R
1814	716 <sub>H</sub>			Second	Day of the week	0	R
1815 to 1819	717 <sub>H</sub> to 71B <sub>H</sub>		System area		—	—	
1820 to 1829	71C <sub>H</sub> to 725 <sub>H</sub>	No. 2	Same as No. 1				
1830 to 1839	726 <sub>H</sub> to 72F <sub>H</sub>	No. 3	Same as No. 1				
1840 to 1849	730 <sub>H</sub> to 739 <sub>H</sub>	No. 4	Same as No. 1				
1850 to 1859	73A <sub>H</sub> to 743 <sub>H</sub>	No. 5	Same as No. 1				
1860 to 1869	744 <sub>H</sub> to 74D <sub>H</sub>	No. 6	Same as No. 1				
1870 to 1879	74E <sub>H</sub> to 757 <sub>H</sub>	No. 7	Same as No. 1				
1880 to 1889	758 <sub>H</sub> to 761 <sub>H</sub>	No. 8	Same as No. 1				
1890 to 1899	762 <sub>H</sub> to 76B <sub>H</sub>	No. 9	Same as No. 1				

Address (decimal)	Address (hexadecimal)	Name		Default *1	Read/Write *2
1900 to 1909	76C <sub>H</sub> to 775 <sub>H</sub>	No. 10	Same as No. 1		
1910 to 1919	776 <sub>H</sub> to 77F <sub>H</sub>	No. 11	Same as No. 1		
1920 to 1929	780 <sub>H</sub> to 789 <sub>H</sub>	No. 12	Same as No. 1		
1930 to 1939	78A <sub>H</sub> to 793 <sub>H</sub>	No. 13	Same as No. 1		
1940 to 1949	794 <sub>H</sub> to 79D <sub>H</sub>	No. 14	Same as No. 1		
1950 to 1959	79E <sub>H</sub> to 7A7 <sub>H</sub>	No. 15	Same as No. 1		
1960 to 1969	7A8 <sub>H</sub> to 7B1 <sub>H</sub>	No. 16	Same as No. 1		

\*1 The default value is a value set after power-on or after resetting the CPU module.

\*2 This shows whether reading the data from or writing the data to the area with programs is possible.

R: Readable

W: Writable

# CHAPTER 4 PROCEDURES BEFORE STARTING THE OPERATION

This chapter describes the procedures before starting the operation.

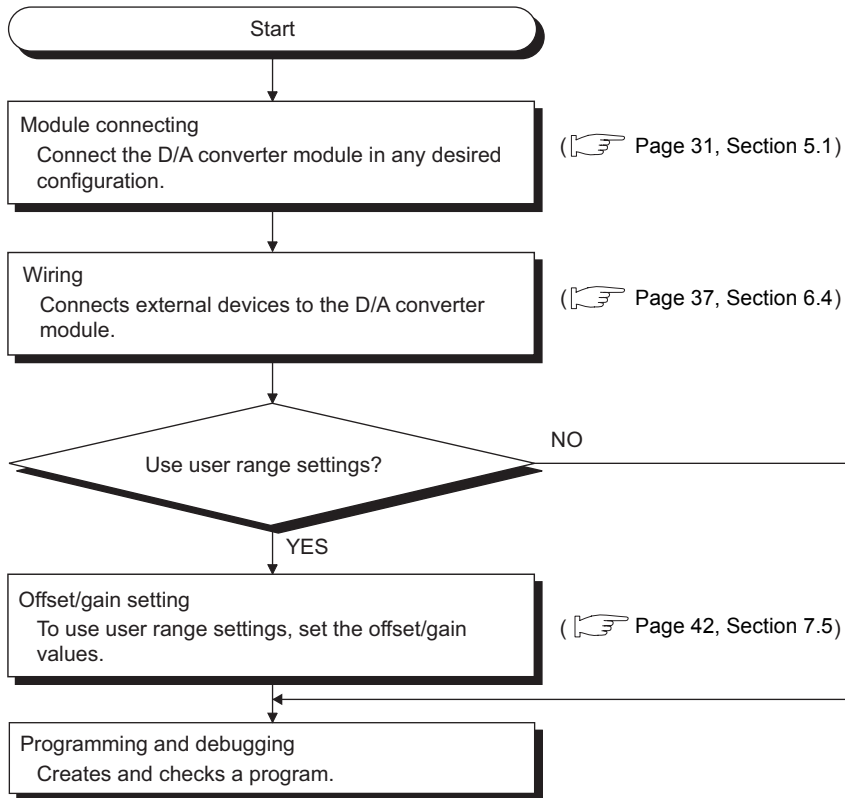

# Memo

---



# CHAPTER 5 SYSTEM CONFIGURATION

This chapter describes the overall configuration, number of connectable modules, and compatible software version of the D/A converter module.

## 5.1 Overall System Configuration

The following shows a system configuration example for using the D/A converter module.

### (1) When connected to a CPU module

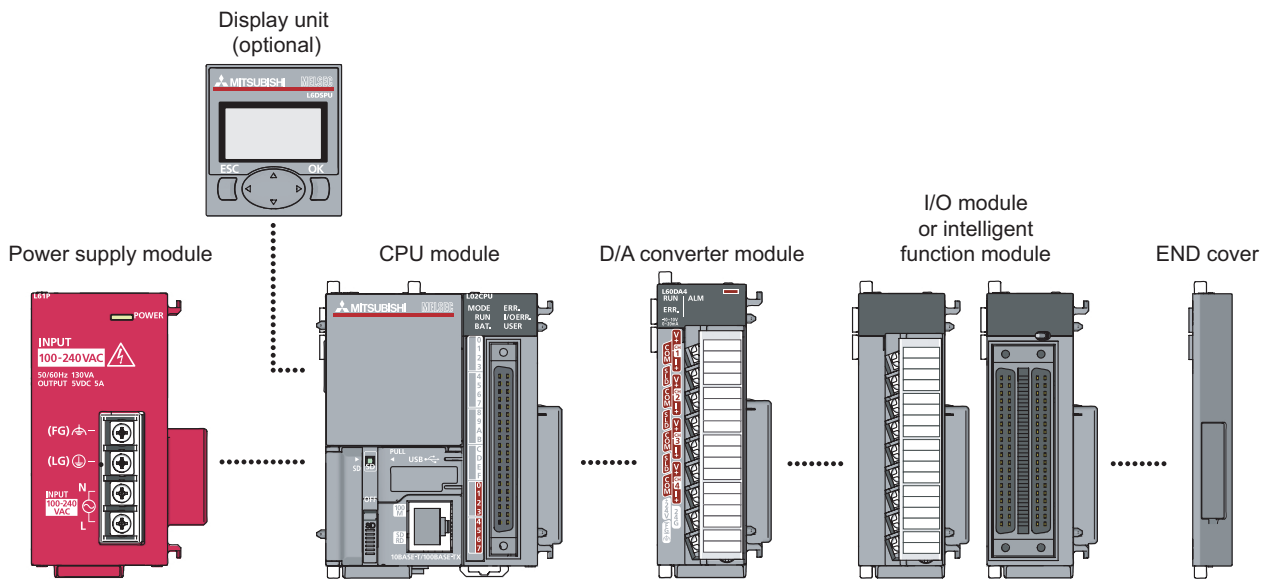

### (2) When connected to a head module

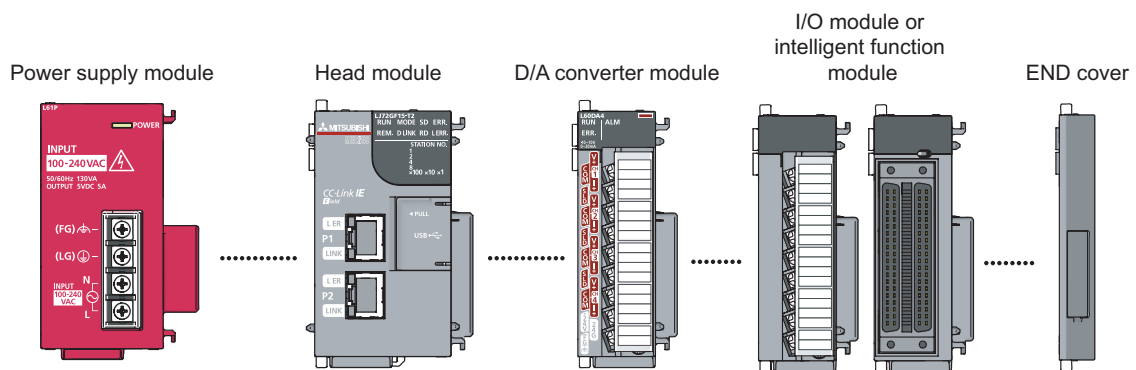



## 5.2 Applicable System

---



### (1) Number of connectable modules

For the number of connectable modules, refer to the following.

-  MELSEC-L CPU Module User's Manual (Hardware Design, Maintenance and Inspection)
-  MELSEC-L CC-Link IE Field Network Head Module User's Manual

### (2) Compatible software version

For the compatible software versions, refer to the following.

-  MELSEC-L CPU Module User's Manual (Hardware Design, Maintenance and Inspection)
-  MELSEC-L CC-Link IE Field Network Head Module User's Manual

## 5.3 Restrictions When D/A Converter Module is Connected to Head Module

---

The following describes the restriction when the D/A converter module is connected to a head module.

- Dedicated instruction cannot be used.

# CHAPTER 6 INSTALLATION AND WIRING



---

This chapter describes the installation and wiring of the D/A converter module.

## 6.1 Installation Environment and Installation Position

---

For precautions for installation environment and installation position, refer to the following.

-  MELSEC-L CPU Module User's Manual (Hardware Design, Maintenance and Inspection)
-  MELSEC-L CC-Link IE Field Network Head Module User's Manual

## 6.2 Terminal Block

### (1) Precautions

Tighten the terminal block screws within the following specified torque range.

Screw type	Tightening torque range
Terminal screw (M3 screw)	0.42 to 0.58N • m
Terminal block mounting screw (M3.5 screw)	0.66 to 0.89N • m

The following table shows the applicable solderless terminal installed to the terminal block. For wiring, use the wire applicable to the following wire and mount with the applicable tightening torque. Use a UL-approved solderless terminal and tools recommended by the manufacturer of the solderless terminal. The sleeve solderless terminal cannot be used.

Solderless terminal		Wire			
Model Name	Applicable tightening torque	Wire diameter	Type	Material	Temperature rating
R1.25-3	0.42 to 0.58N • m	22 to 18 AWG	Stranded wire	Copper wire	75°C or higher

### (2) Signal names of the terminal block

The following shows signal names of the terminal block.

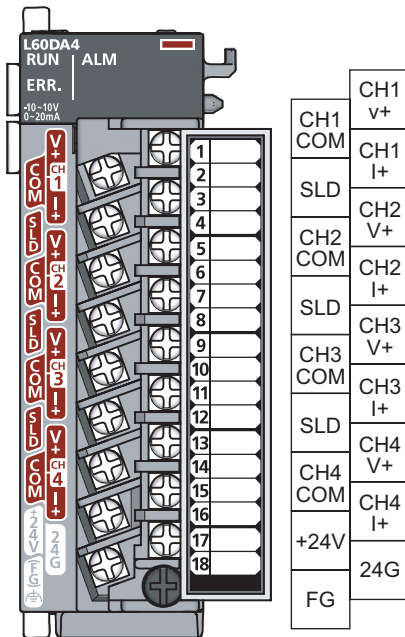

Pin number	Signal name	
1	CH1	V+
2		COM
3		I+
4	SLD	
5	CH2	V+
6		COM
7		I+
8	SLD	
9	CH3	V+
10		COM
11		I+
12	SLD	
13	CH4	V+
14		COM
15		I+
16	+24V	
17	24G	
18	FG	

### (3) Removal and installation of the terminal block

The following shows how to remove and install the terminal block.

#### (a) Removal procedure

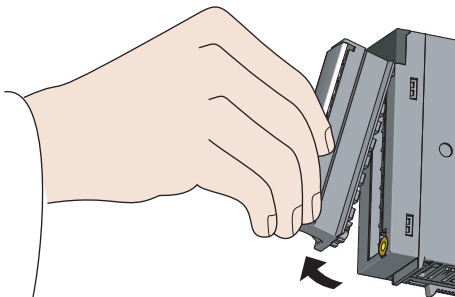
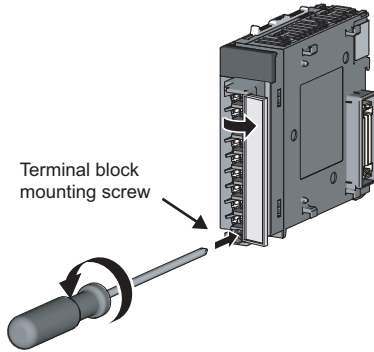

1. Open the terminal cover and loosen the terminal block mounting screw.

2. Using the terminal block fixing holes as a fulcrum, remove the terminal block.

#### (b) Installation procedure

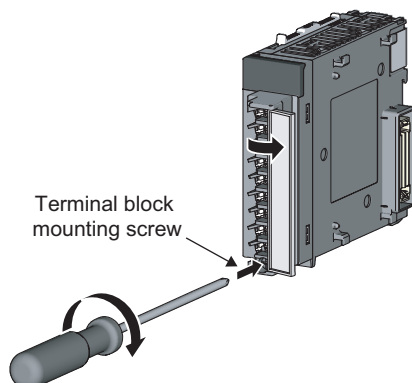
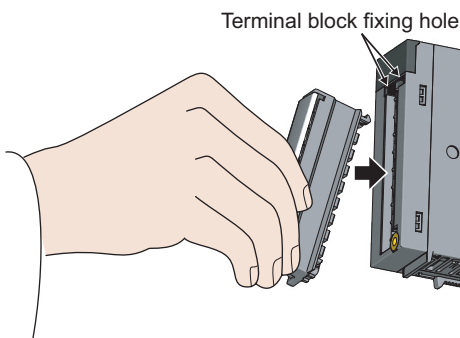

1. Fully insert the projections on the top of the terminal block into the terminal block fixing holes and press the terminal block until it snaps into place.

2. Open the terminal cover and tighten the terminal block mounting screw.

# 6.3 Wiring

## (1) Wiring to a terminal block

The following shows wirings to a terminal block.

### (a) For voltage output

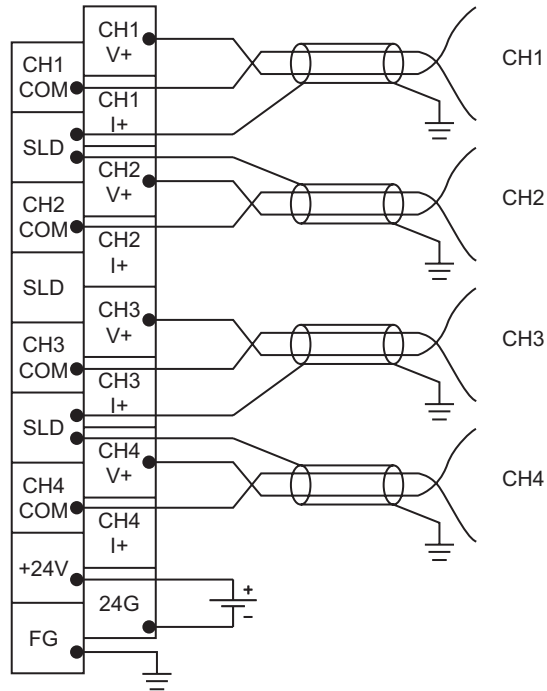

### (b) For current output

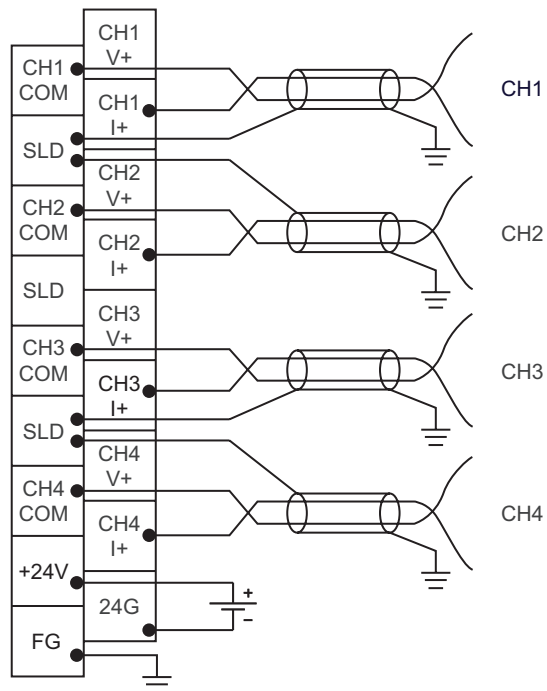

## 6.4 External Wiring

The following describes the external wiring.

### (1) For voltage output

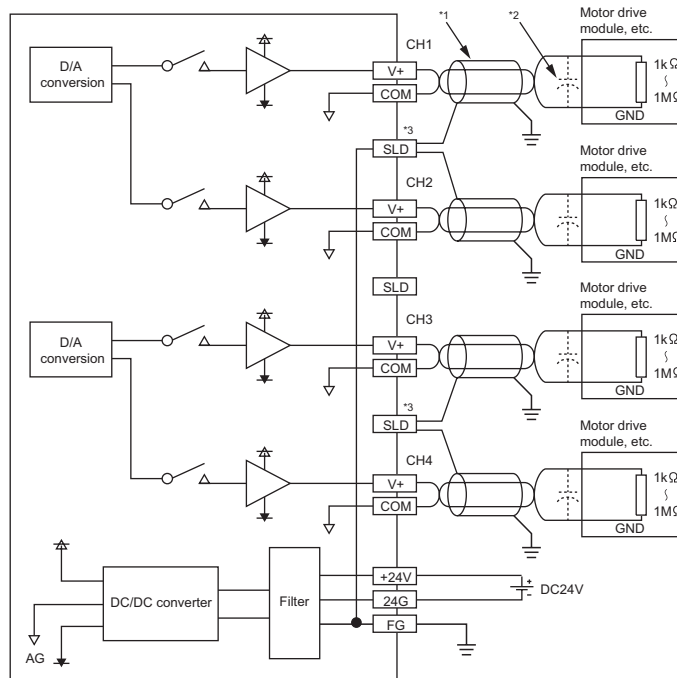

### (2) For current output

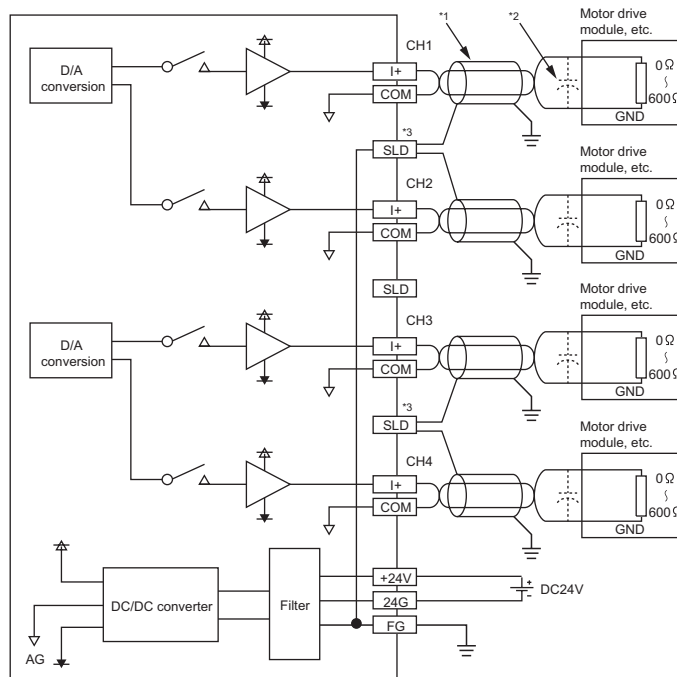

- \*1 For wire, use the shielded twisted pair cable.
- \*2 For external wiring, if noise or ripple occurs, connect a capacitor with values between  $0.1\mu\text{F}$  and  $0.47\mu\text{F}$  with voltage around of 25V between terminal (V+) and COM.
- \*3 Connect the each channel shielded wire to any one of three shield terminals for the channel. Be sure to ground the FG terminal.  
In addition, ground the FG terminal of the power supply module.

# CHAPTER 7 VARIOUS SETTINGS

This chapter describes the setting procedures of the D/A converter module.

## Point

After writing the contents of new module, switch settings, parameter settings and auto refresh settings into the CPU module, reset the CPU module, switch STOP → RUN → STOP → RUN, or switch OFF → ON the power supply, to validate the setting contents.

## 7.1 Addition of Modules

Add the model name of D/A converter modules to use on the Project.

### (1) Addition procedure

Open the "New Module" dialog box.

Project window ⇨ [Intelligent Function Module] ⇨ Right-click ⇨ [New Module...]

Item		Description
Module Type	Module Type	Set "analog module".
	Module Name	Select the name of the module to be connected.
Mount Position	Mounted Slot No.	Set the slot No. where the target module is connected.
	Specify start X/Y address	The start I/O number (hexadecimal) of the target module is set, according to the mounted slot No. Setting any start I/O number is also possible.
Title Setting	Title	Set any title.



## 7.2 Switch Setting

Set the operation mode, HOLD/CLEAR function, and the output range used in each CH.

### (1) Setting procedure

Open the "Switch Setting" dialog box.

 Project window ⇨ [Intelligent Function Module] ⇨ module name ⇨ [Switch Setting]

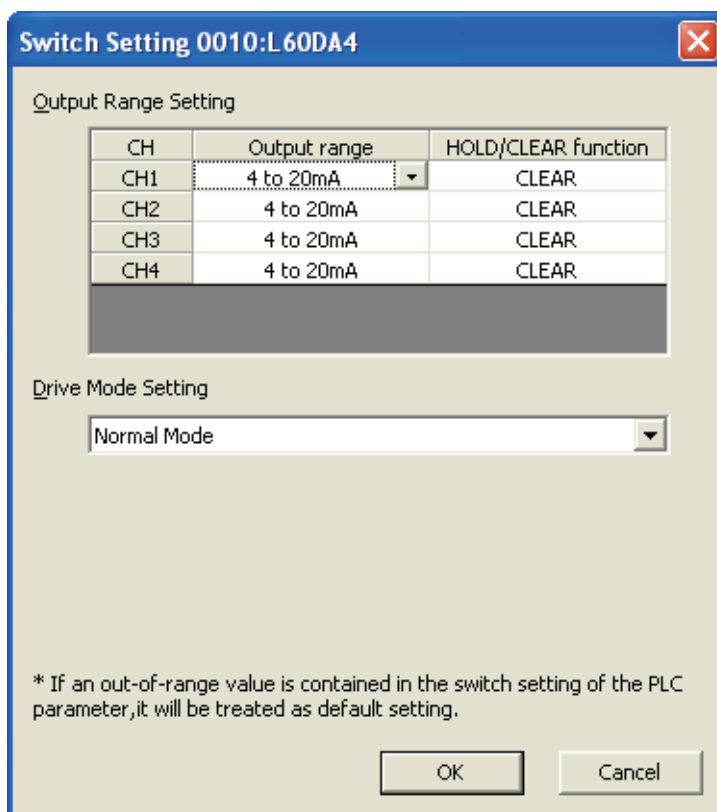

Item		Description	Setting value
Output Range Setting	Output range	Set the output range used in each CH.	<ul style="list-style-type: none"> <li>• 4 to 20mA (default value)</li> <li>• 0 to 20mA</li> <li>• 1 to 5V</li> <li>• 0 to 5V</li> <li>• -10 to 10V</li> <li>• User range setting</li> </ul>
	HOLD/CLEAR function	Set whether to hold or clear the output analog value in each CH when the CPU module enters to the STOP status or when an error occurs.	<ul style="list-style-type: none"> <li>• CLEAR (default value)</li> <li>• HOLD</li> </ul>
Operation Mode Setting		Set the operation mode of the D/A converter module.	<ul style="list-style-type: none"> <li>• Normal mode (default value)</li> <li>• Offset/gain setting mode</li> </ul>

## 7.3 Parameter Setting

Set the parameters of each CH.

### (1) Setting procedure

Open the "Parameter" dialog box.

#### 1. Start "Parameter"

Project window ⇒ [Intelligent Function Module] ⇒ module name ⇒ "Parameter"

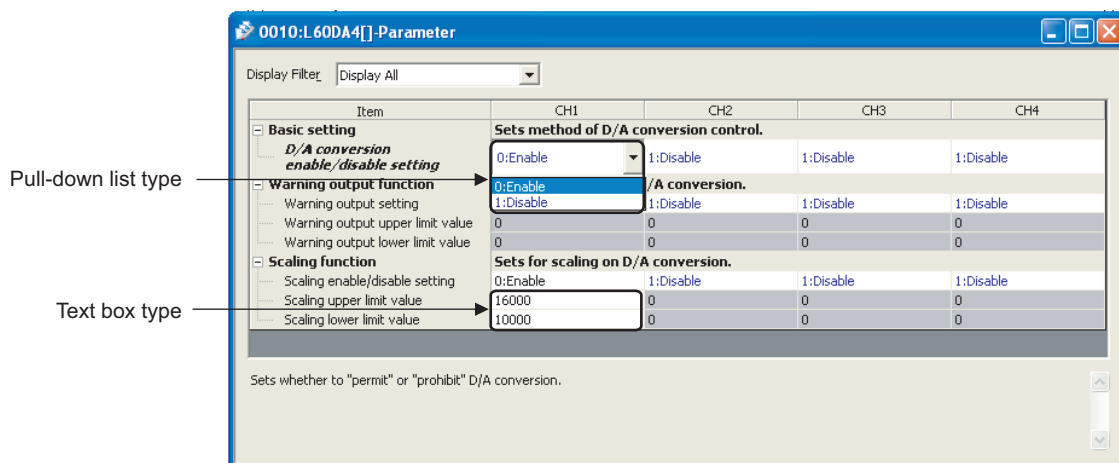

#### 2. Double-click the item to change the setting, and input the setting value.

- Items to input from the pull-down list  
Double-click the item to set, to display the pull-down list. Select the item.
- Items to input from the text box  
Double-click the item to set, and input the setting value.

#### 3. For setting CH2 to CH4, follow the operation of step2.

Item		Setting value	Reference
Basic setting	D/A conversion enable/disable setting	0: Enable 1: Disable (default value)	Page 49, Section 8.1
Warning Output Function	Warning output setting	0: Enable 1: Disable (default value)	Page 59, Section 8.6
	Warning output upper limit value	-32768 to 32767 (default value: 0)	
	Warning output lower limit value	-32768 to 32767 (default value: 0)	
Scaling function	Scaling function	0: Enable 1: Disable (default value)	Page 54, Section 8.5
	Scaling upper limit value	-32000 to 32000 (default value: 0)	
	Scaling lower limit value	-32000 to 32000 (default value: 0)	

## 7.4 Auto Refresh

This setting transfers data in the buffer memory to specified devices.

### (1) Setting procedure

Open the "Auto\_Refresh" dialog box.

#### 1. Start "Auto\_Refresh"

Project window ⇒ [Intelligent Function Module] ⇒ module name ⇒ [Auto\_Refresh]

#### 2. Click the item to setup, and input the auto refresh target device.

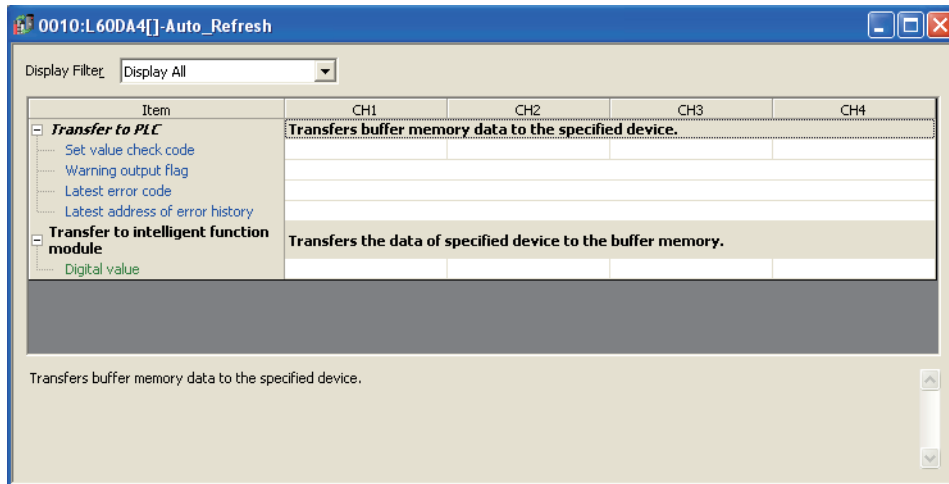

## 7.5 Offset/Gain Setting

---

When using the user range setting, configure the offset/gain setting with the following operations.

When using the factory default setting, the offset/gain setting is not necessary.

The offset/gain setting can be configured from the following two types of operations.

- Setting from "Offset/Gain Setting" of GX Works2.
- Setting from a program

### 7.5.1 Setting from GX Works2 "Offset/Gain Setting"

---

#### (1) Setting procedure

Open the "Offset/Gain Setting" dialog box.

 [Tool] ⇨ [Intelligent Function Module Tool] ⇨ [Analog Module] ⇨ [Offset/Gain Setting]

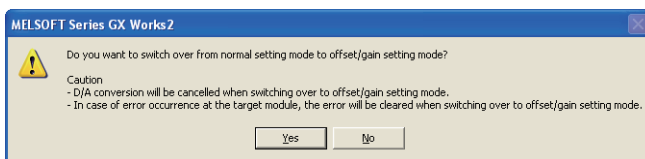
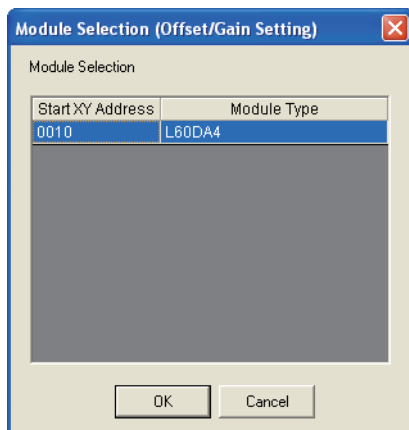

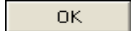
**1. Select the module to configure the offset/gain setting, and click the  button.**

**2. Click the  button.**

3. Specify the channel to use the offset/gain setting.

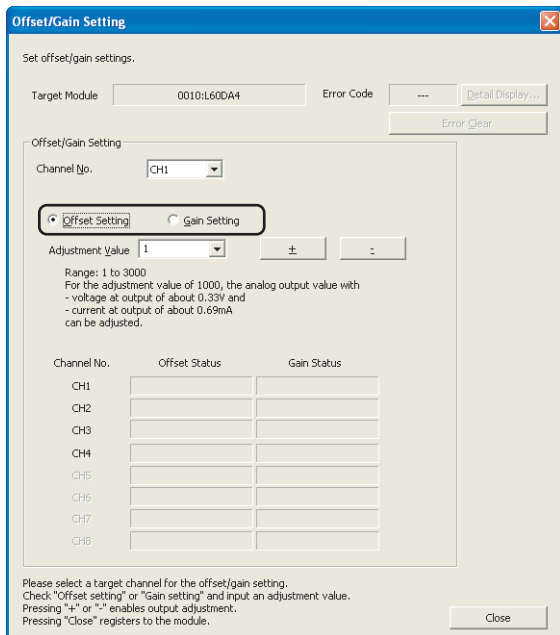
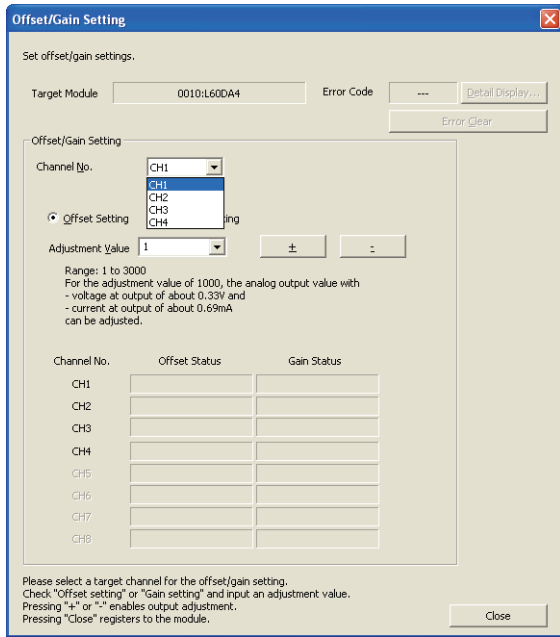

4. Use the radio button to specify whether to perform the offset setting or gain setting. (Step 5 and later describes when the offset setting is specified.)



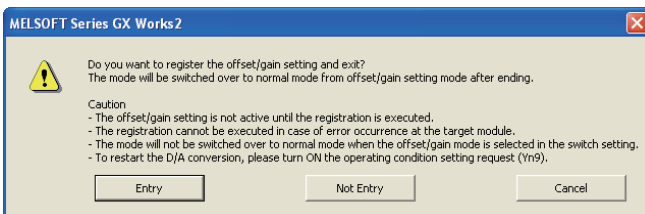
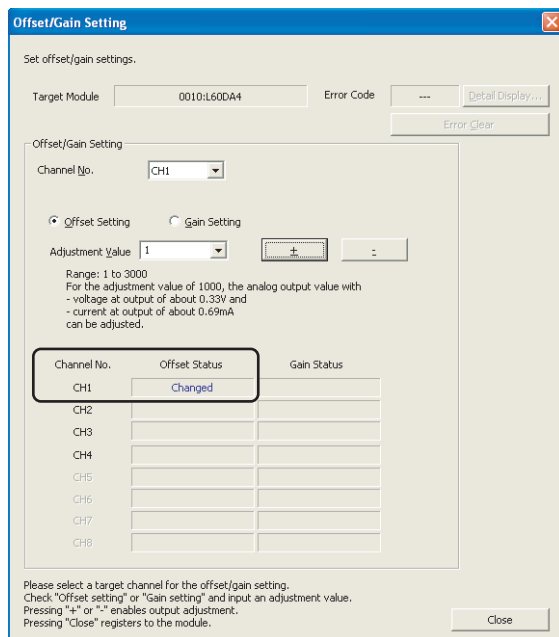
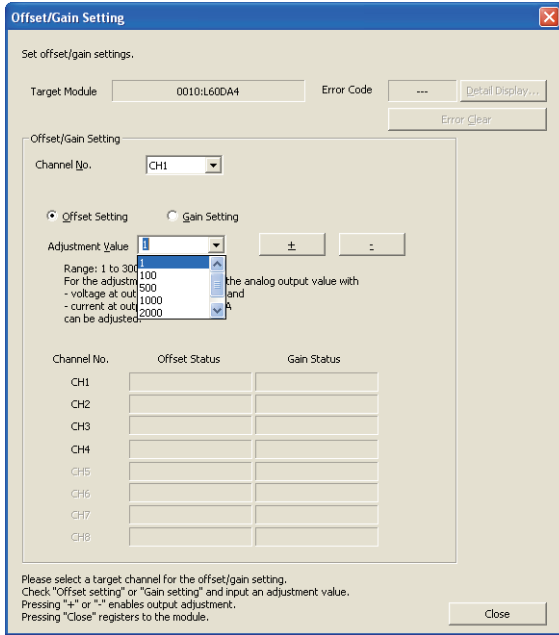

7.5 Offset/Gain Setting  
 7.5.1 Setting from GX Works2 "Offset/Gain Setting"



End

5. The adjustment amount of the offset value or gain value can be selected from "1", "100", "500", "1000", "2000", and "3000" or it can be set by inputting any value (1 to 3000).

6. Clicking the  or  button fine-adjusts the analog output voltage or analog output current value by the set adjusted value.

7. The offset status in the specified channel is changed to "Changed".

8. To perform the gain setting, repeat from step 4.

9. After setting, click the  button.

10. Click the  button.

## 7.5.2 Setting from a program

### (1) Setting procedure

The following describes the procedures when setting the offset/gain from a program.

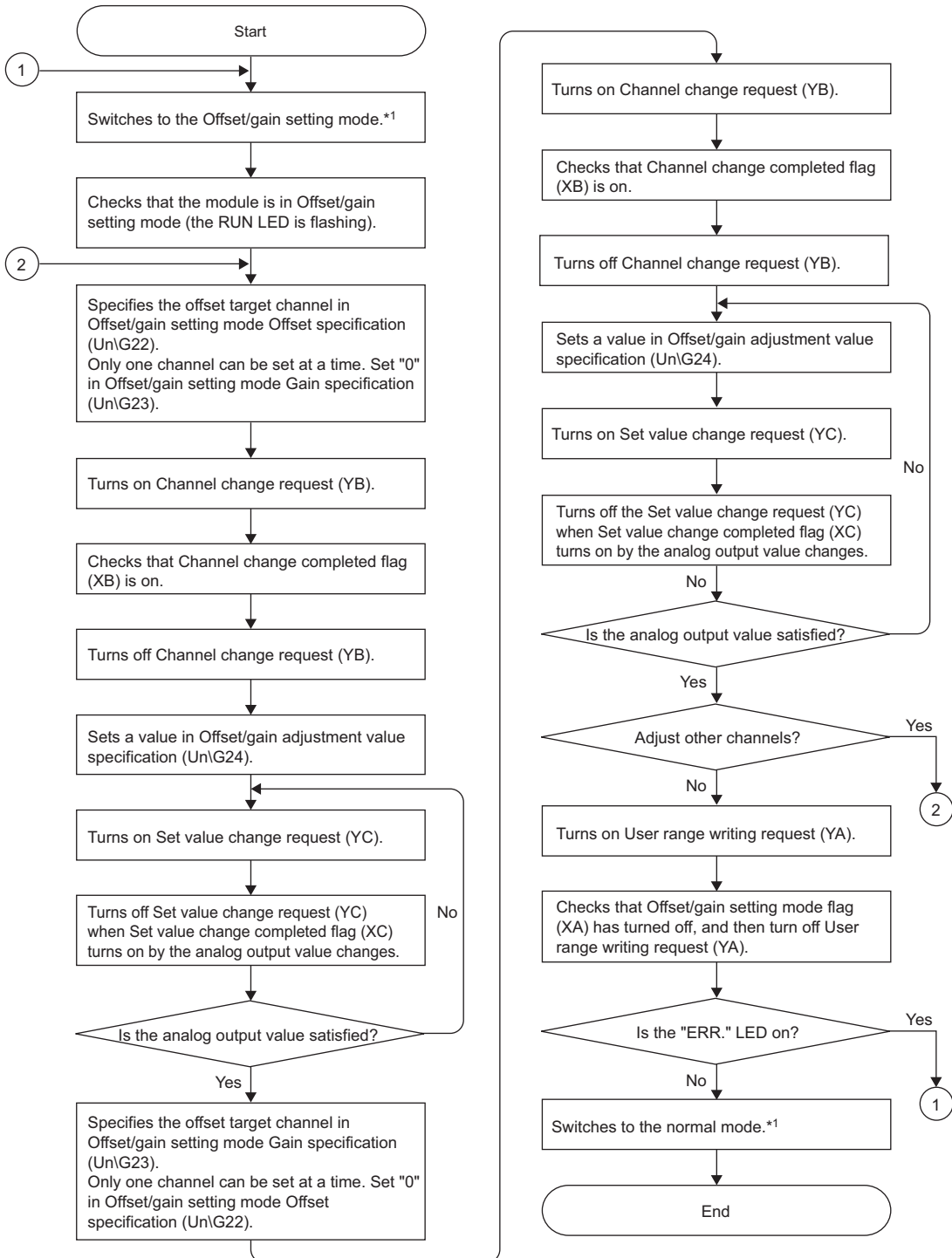

\*1 The following shows the procedure for switching the mode (normal mode → offset/gain setting mode → normal mode).  
 Dedicated instruction (G(P).OFFGAN) (☞ Page 116, Appendix 5.2)  
 • Changing for Mode switching setting (UnG158, UnG159) and OFF → ON → OFF of Operating condition setting request (Y9) (☞ Page 110, Appendix 2(14))  
 • Intelligent function module switch setting (☞ Page 39, Section 7.2 (1))

## Point

- Configure the offset/gain setting in accordance with the actual use situation.
- Offset and gain values are recorded in the flash memory in the D/A converter module by turning OFF → ON → OFF User range writing request (YA). Once recorded, the values are not deleted even after turning the power off. When the values are written 26 times in succession, an error occurs and the error code is stored in Latest error code (Un\G19) to prevent an improper write to flash memory.
- Configure the offset/gain setting in the range satisfying the following condition.  
When the setting value out of the range is configured, the resolution and accuracy of the module may not fall within the range shown in the following performance specifications.
  - I/O conversion characteristic of D/A conversion (☞ Page 112, Appendix 3)
- Configure the offset/gain setting for each channel.  
When configuring the setting for offset and gain channels at the same time, an error occurs and ERR. LED turns on.
- When error occurs even in one channel, offset/gain value is not written to the module.  
Check the value in Latest error code (Un\G19) and perform the following procedures to reconfigure the offset/gain setting from the beginning.
  - Error code list (☞ Page 93, Section 11.4)
- When the mode is switched from the offset/gain setting mode to the normal mode by the setting of the dedicated instruction (G(P).OFFGAN) or Mode switching setting (Un\G158, Un\G159), Module READY (X0) turns from OFF to ON. Note the initial setting process is executed at the switching of the mode if the sequence program executes the initial setting at Module READY (X0) ON.
- To validate the intelligent function module switch setting after writing the setting to the CPU module, reset the CPU module or turn the power supply from OFF to ON.

## (2) Program example

### (a) Device

**Ex.** I/O number of D/A converter module is X/Y30 to 3F (when L26CPU-BT is used)

The following shows the devices used in the program example.

Device	Function
M0	Channel selection
M2	Gain setting
M3	Channel change command
M4	Offset/gain setting value channel change command
M5	Mode switching
M6	Analog output value adjustment command
M7	Command to write offset/gain setting values to the module
M8	Adjustment amount setting
M50	Signal for checking the offset/gain setting mode
M51	Signal for checking the normal mode
D0	Channel-specified storage device
D1	Adjustment amount setting storage device
D2	Storage device for the setting value of the dedicated instruction (G(P).OFFGAN)
M100	Module READY checking flag

## Point

For configuring the same I/O assignment as the system above, when using L02CPU, set the I/O assignment of the D/A converter module within X/Y30 to 3F.



**(b) Switching the mode by the dedicated instruction (G.OFFGAN)**

This program performs the followings:

- first, switches the mode to the offset/gain setting mode by the dedicated instruction (G.OFFGAN),
- second, switches the channels for which the offset/gain settings are configured,
- third, writes the offset/gain value to the D/A converter module,
- finally, switches the mode back to the normal mode.

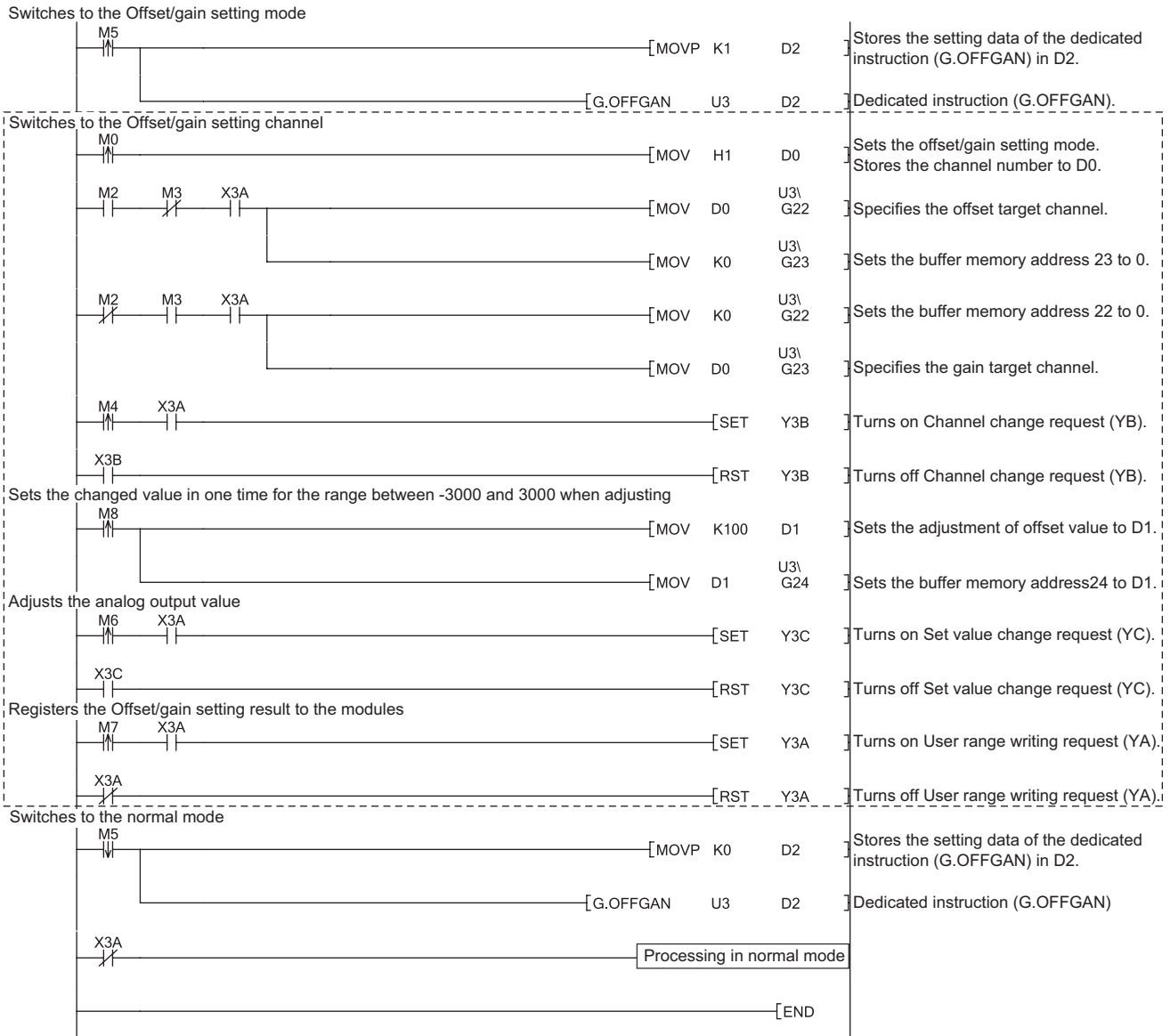

**Point**

The program in the dot-line box is common with the following three programs.

- Switching the mode by the dedicated instruction (G(P).OFFGAN)
- Switching the mode by Mode switching setting (U3\G158, U3\G159) and Operating condition setting request (Y39)
- Switching the mode by the intelligent function module switch setting

**(c) Switching the mode by Mode switching setting (Un\G158, Un\G159) and Operating condition setting request (Y9)**

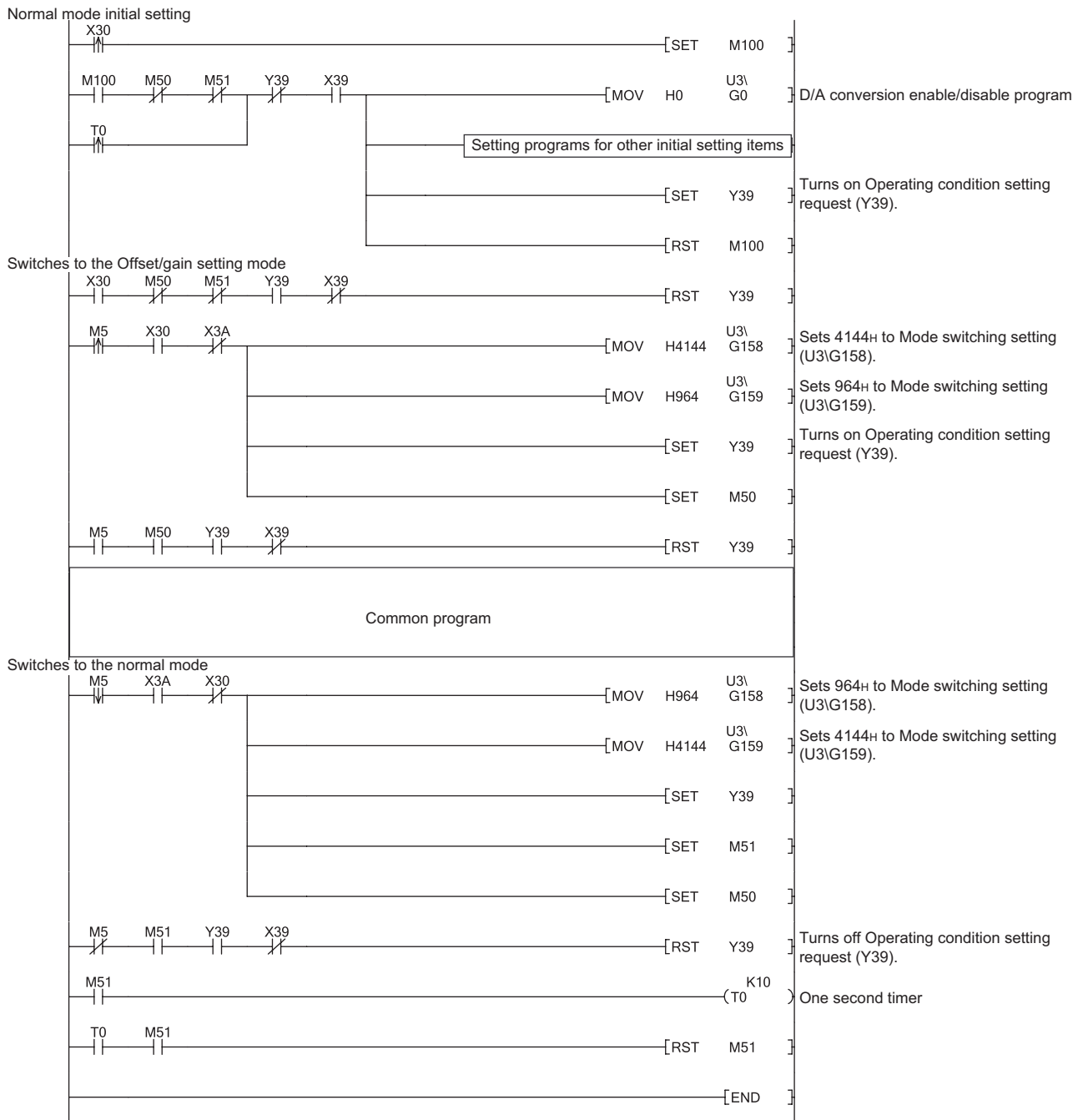

**(d) Switching the mode by the intelligent function module switch setting**

The program other than the common program is not required.

# CHAPTER 8 FUNCTIONS

This chapter describes the details on functions that can be used in the D/A converter module and the setting procedures.

For details on I/O signals and buffer memory, refer to the following.

- Detail of I/O signals (☞ Page 98, Appendix 1)
- Details of buffer memory addresses (☞ Page 104, Appendix 2)

## 8.1 D/A Conversion Enable/Disable Function

This function sets whether to enable or disable the analog value output for each channel. Disabling the D/A conversion for unused channels reduces the conversion cycles.

### (1) Setting procedure

Set "D/A conversion enable/disable setting" to "0: Enable".

☞ Project window ⇒ [Intelligent Function Module] ⇒ module name ⇒ [Parameter]

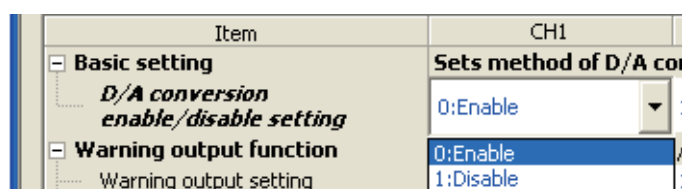

## 8.2 D/A Output Enable/Disable Function

This function sets whether to output the D/A conversion value or the offset value, for each channel. The conversion speed is constant, regardless of the output enable/disable status.

### (1) Setting procedure

Configure the setting with CH□ Output enable/disable flag (Y1 to Y4)

CH□ Output enable/disable flag (Y1 to Y4)	Analog output
Enable (ON)	D/A conversion value is output.
Disable (OFF)	Offset value is output.

## 8.3 Analog Output HOLD/CLEAR Function

This function sets whether to hold the output analog value (HOLD) or clear the output analog value (CLEAR), according to the CPU module operating status (RUN, STOP or stop error).

### (1) Combination of analog output statuses

The analog output status changes as shown in the following table, depending on the combination of settings for D/A conversion enable/disable setting (Un\G0) and CH□ Output enable/disable flag (Y1 to Y4).

Execution status	D/A conversion enable/disable setting (Un\G0)	Enable		Disable
	CH□ Output enable/disable flag (Y1 to Y4)	Enable		Disable
	Analog output HOLD/CLEAR function setting	HOLD	CLEAR	HOLD or CLEAR
Analog output status when CPU module is in RUN status		Analog value converted from digital value with D/A conversion is output.		Offset value
Analog output status when CPU module is in STOP status		Hold	Offset value	Offset value*2
Analog output status when CPU module is in stop error		Hold	Offset value	Offset value
Analog output status when a watchdog timer error*1 occurs		0V/0mA	0V/0mA	0V/0mA

\*1 Occurs when the program operation is not completed within the estimated time due to such as a hardware trouble in the D/A converter module. When a watchdog timer error occurs, Module READY (X0) turns OFF and the RUN LED on the D/A converter module turns off.

\*2 The following operation is performed when the CPU module is in STOP status, D/A conversion enable/disable setting (Un\G0) is set to D/A conversion enabled (0) and Operating condition setting request (Y9) is turned to OFF → ON → OFF.

Output enable/disable flag OFF: 0 V/0 mA output

Output enable/disable flag OFF → ON: offset value output

### (2) Setting procedure

Configure the setting from "HOLD/CLEAR function".

🔍 Project window ⇨ [Intelligent Function Module] ⇨ module name ⇨ [Switch Setting]

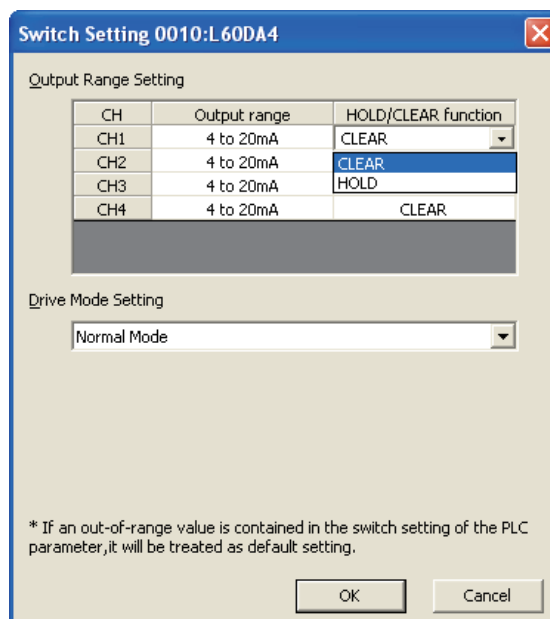



The following describes the conditions for using the analog output HOLD/CLEAR function with a head module.

- Enable the station-based block data assurance of the cyclic data on the send side.
- When a link error occurs, configure the setting to hold the D/A conversion output through "I/O assignment setting error output mode" \*1. The HOLD/CLEAR setting configured from the Switch Setting of the intelligent function module switch will be invalid.

This setting is enabled for each module. Setting by each channel are not available.

Therefore, set the HOLD/CLEAR function to the same setting for all channels in order to match the output status when a CPU module occurs a stop error or actually stopped and when a link error occurs.

Project window ⇨ [Parameter] ⇨ [PLC Parameter] ⇨ [I/O Assignment]

⇨ Detailed Setting button

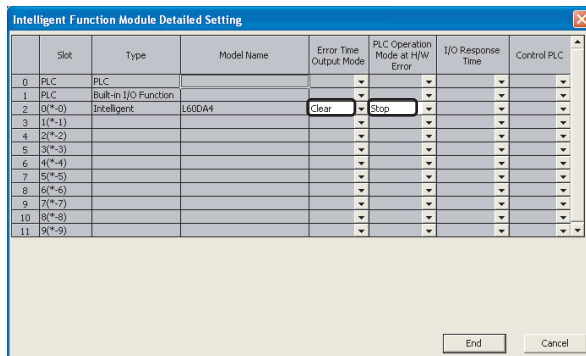

Operating status	Error time output mode *1	HOLD/CLEAR setting (All channels should be the same settings)
Holds the analog output	Hold	HOLD
Clears the analog output (Outputs offset value)	Clear	CLEAR

For the block guarantee of cyclic data per station, refer to the following manual.

MELSEC-Q CC-Link IE Field Network Master/Local Module User's Manual

- \*1 When the error time output mode is enabled
- Data link stopped due to a network error
  - Data link is stopped by CC-Link IE Field diagnostics using GX Works2

## 8.4 Analog Output Test when CPU Module is in STOP Status

Analog output test can be performed when CPU module is in STOP status.

When the following settings are configured, the settings are enabled even during the analog output test.

- Alarm output function (☞ Page 59, Section 8.6)
- Scaling Function (☞ Page 54, Section 8.5)

When a digital value out of the range is written to each channel, a check code is stored in CH□ Set value check code (Un\G11 to Un\G14).

### (1) Setting procedure

For analog output test, configure the following settings in the device test of GX Works2.

1. Set D/A conversion enable/disable setting (Un\G0) to "enable" for the channel where the analog output test is to be performed.
2. Turn OFF → ON → OFF Operating condition setting request (Y9).
3. Turn OFF → ON Output enable/disable flag (Y1 to Y4) for the channel where the analog output test is to be performed.
4. Set the digital value equivalent to the analog value to be output to CH□ Digital value (Un\G1 to Un\G4) in buffer memory.

Setting combination	D/A conversion enable/disable setting (Un\G0)	Enable		Disable	
	CH□ Output enable/disable flag (Y1 to Y4)	Enable	Disable	Enable	Disable
Analog output test		Allowed	Not allowed	Not allowed*1	

\*1 When performing the analog output test, set D/A conversion enable/disable setting (Un\G0) to "enable" beforehand.

### (2) Operation timing

By forcibly turning CH□ Output enable/disable flag (Y1 to Y4) OFF → ON when the CPU module is in STOP status, analog output value is changed from offset value to D/A-converted analog value.

The following shows the relation between CH1 Output enable/disable flag (Y1) and analog output value when the CPU module is in STOP status.

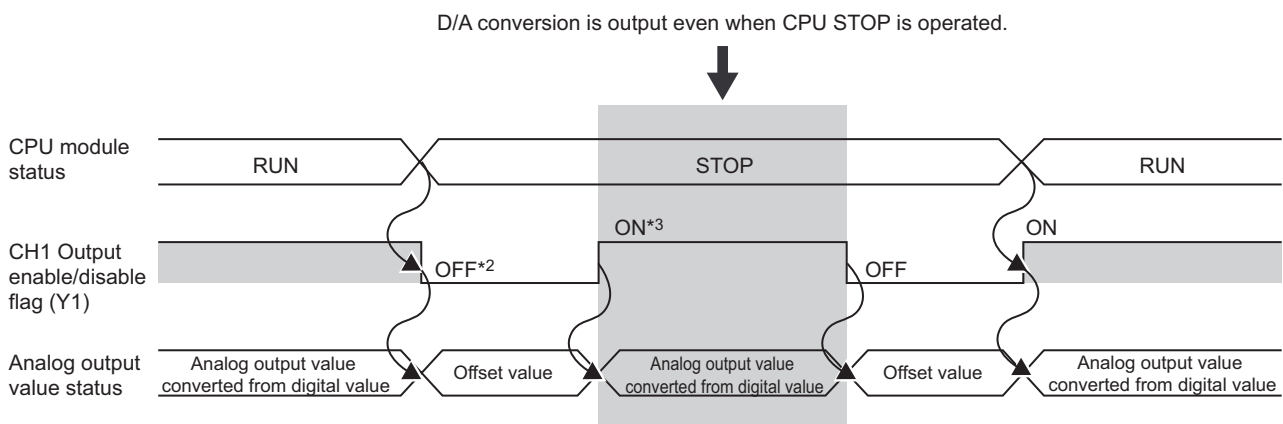

\*2 CH1 Output enable/disable flag (Y1) turns OFF with CPU STOP.

\*3 By forcibly turning the CH1 Output enable/disable flag (Y1) OFF → ON, analog output value is changed from offset value to D/A-converted analog value.

**Point** 

---

Analog output tests can be performed if a head module is connected even when the CPU module is stopped due to an error.

---

## 8.5 Scaling Function

This function converts the input digital value to the scaled value of -20000 to 20000 (or 0 to 20000) using the specified scaling upper and lower limit values, and outputs the corresponding analog value.

### (1) Concept of scaling setting

The setting for scaling lower and upper limit values differs depending on either the factory default setting or the user range setting is used for analog output range.

#### (a) When the factory default setting is used for analog output range

When using the factory default range, set a value corresponding to the upper limit value of the analog output value of the factory default range for the scaling upper limit value. Also, set a value corresponding to the lower limit value of the analog output of the factory default range for the scaling lower limit value.

#### (b) When the user range setting is used for analog output range

When using the user range, set a value corresponding to the analog output gain value for the scaling upper limit value. Also, set a value corresponding to the analog output offset value for the scaling lower limit value.

### (2) Calculating the scaling value

Values converted using the following formulas are used for D/A conversion.

(Values lower than the decimal point are rounded down in scale conversion.)

#### (a) When the factory default setting is used for output range

- Voltage: 1 to 5 V, 0 to 5 V  
Current: 4 to 20 mA, 0 to 20 mA

$$\text{Digital value used for D/A conversion} = \frac{20000}{SH - SL} \times (Dx - SL)$$

- When the voltage is -10 to 10 V

$$\text{Digital value used for D/A conversion} = \frac{40000}{SH - SL} \times (Dx - SL) - 20000$$

#### (b) When the user range setting is used for output range

$$\text{Digital value used for D/A conversion} = \frac{20000}{SH - SL} \times (Dx - SL)$$

Item	Description
Dx	digital value
DMax	digital maximum value of the used output range
DMin	digital minimum value of the used output range
SH	scaling upper limit value
SL	Scaling lower limit value

#### **Point**

Even if the input range of digital value is increased, the resolution does not become higher than that of when the scaling function is not used.



### (3) Setting procedure

1. Set "D/A conversion enable/disable setting" to "0: Enable".

 Project window ⇨ [Intelligent Function Module] ⇨ module name ⇨ [Parameter]

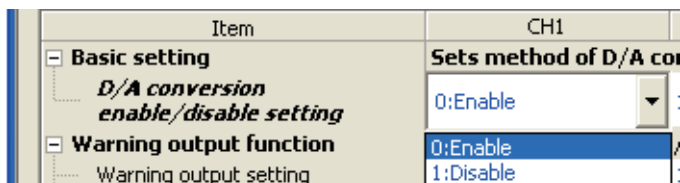

2. Set "Scaling function" to "0: Enable".

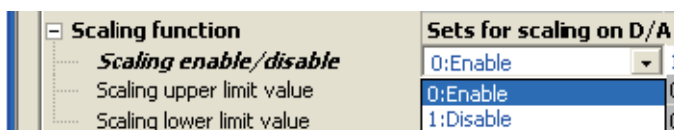

3. Set values for "Scaling upper limit value" and "Scaling lower limit value".

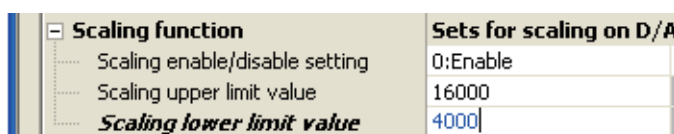

Item	Setting range
Scaling upper limit value	-32000 to 32000
Scaling lower limit value	

**Point** 

- Your scaling settings must meet the following condition:  
Scaling upper limit value > Scaling lower limit value

#### (4) Scaling setting example

**Ex.** 1. When setting the "Scaling upper limit value" to "16000" and the "Scaling lower limit value" to "4000" for a channel with output range of 0V to 5V:

Scaling function	Sets for scaling on D/A
Scaling enable/disable setting	0:Enable
Scaling upper limit value	16000
<i>Scaling lower limit value</i>	4000

The following shows the digital values before and after scaling.

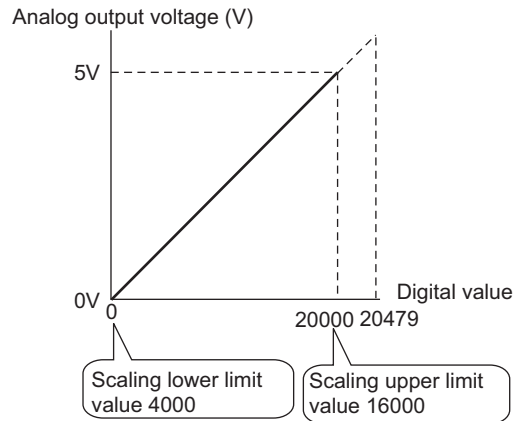

Analog output voltage (V)	Digital value	Digital value after scaling
0	4000	0
1	6400	4000
2	8800	8000
3	11200	12000
4	13600	16000
5	16000	20000

**Ex.** 2. When setting the "Scaling upper limit value" to "16000" and the "Scaling lower limit value" to "4000" for a channel with output range of -10V to 10V:

Scaling function	Sets for scaling on D/A
Scaling enable/disable setting	0:Enable
Scaling upper limit value	16000
<b>Scaling lower limit value</b>	<b>4000</b>

The following shows the digital values before and after scaling.

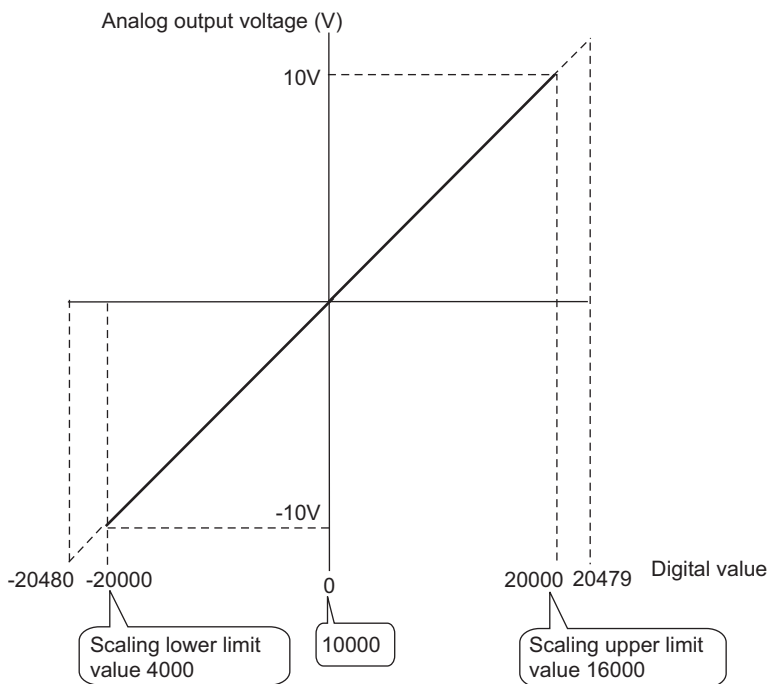

Analog output voltage (V)	Digital value	Digital value after scaling
-10	4000	-20000
-5	7000	-10000
0	10000	0
5	13000	10000
10	16000	20000

**Ex. 3:** When setting the "Scaling upper limit value" to "16000" and the "Scaling lower limit value" to "4000" for a channel with output range of -8V to 8V:

Scaling function		Sets for scaling on D/A
Scaling enable/disable setting		0:Enable
Scaling upper limit value		16000
Scaling lower limit value		4000

The following shows the digital values before and after scaling.

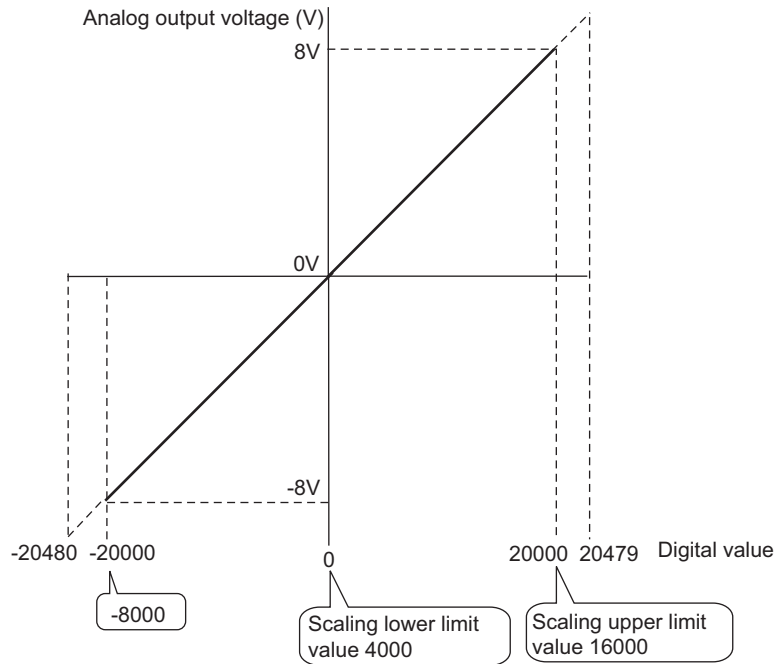

Analog output voltage (V)	Digital Value	Digital value after scaling
-8	-8000	-20000
-4	-2000	-10000
0	4000	0
4	10000	10000
8	16000	20000

### Point

- When using the scaling function, the digital value before scaling can be set to a value out of the range of scaling upper and lower limit values (dotted line area in the I/O characteristics). However, use the scaling function within the range of analog output practical range (solid line area in the I/O characteristics). If the value exceeds the analog output practical range, the resolution and accuracy may not fall within the range of performance specifications.
- The default digital value "0" may not be appropriate, depending on the scaling function setting. Especially in the examples 1 and 2, the out-of-range digital value error (error code: 60□) occurs if the output enable/disable flag is turned on with the digital value "0". Therefore, be sure to set an appropriate digital value, within the scaling range, before turning on the output enable/disable flag. The following shows the error codes that occur.

60□  
Fixed Error channel number

- When using the user range, note that the scaling lower limit value is equal to the offset value.

## 8.6 Alarm Output Function

This function outputs an alarm when the digital value is out of the preset range.

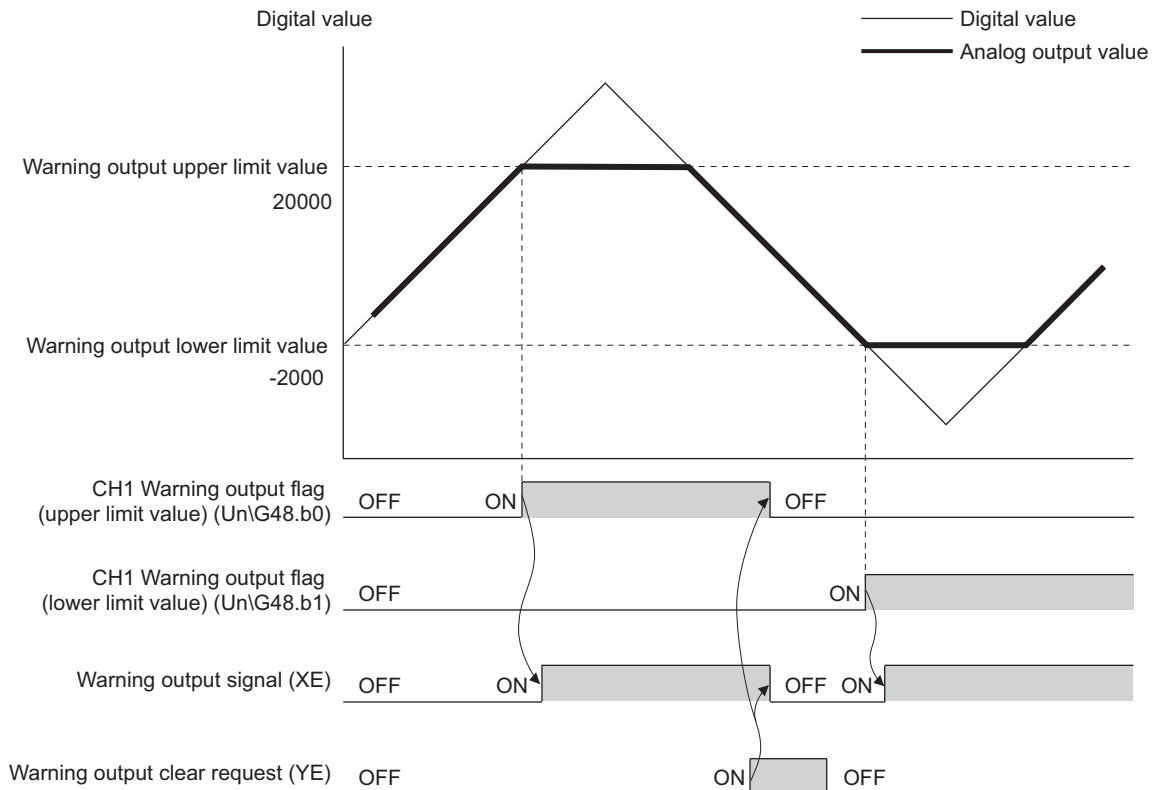

### (1) Alarm output notification

When the digital value moves above the alarm output upper limit value, or below the alarm output lower limit value, alarm notifications are made by Warning output flag (Un\G48), Warning output signal (XE) and the ALM LED turning ON.

In addition, alarm code 15  $\Delta$ □ is stored in Latest error code (Un\G19).

The alarm code that is stored is shown below:

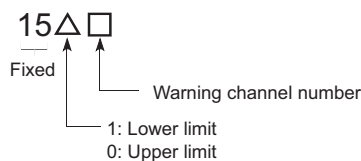

### (2) Operation of alarm output function

When the digital value moves above the alarm output upper limit value, or below the alarm output lower limit value, alarm notifications are made, and the analog output value becomes any of the following.

- When the digital value exceeds the alarm output upper limit value: An analog value converted from the digital value of alarm output upper limit value is output.
- When the digital value is less than the alarm output lower limit value: An analog value converted from the digital value of alarm output lower limit value is output.

After an alarm has occurred, the analog output value returns to the normal value by changing the digital value to a value within the setting range. However, Warning output flag (Un\G48) and Warning output signal (XE) are not cleared. (ALM LED keeps ON.)

### (3) Clearing the Warning output

The alarm output can be cleared in the following two procedures:

- Turning OFF → ON → OFF Warning output clear request (YE)
- Turning OFF → ON → OFF Operating condition setting request (Y9)

Clearing the alarm output puts the D/A converter module into the following status.

- Warning output flag (Un\G48) is cleared.
- Warning output signal (XE) is turned to OFF.
- ALM LED is turned off.
- Warning code: 15△□ stored in Latest error code (Un\G19) is cleared.

### (4) If the scaling function is enabled

If Scaling enable/disable setting (Un\G53) is set to "Enable", the digital value converted to the scaling range becomes a subject for alarm detection.

When setting CH1 Warning output upper limit value (Un\G86) to CH4 Warning output lower limit value (Un\G93), make sure to specify values that reflect the scaling range.

### (5) Setting procedure

#### 1. Set "D/A conversion enable/disable setting" to "0: Enable".

Project window ⇨ [Intelligent Function Module] ⇨ module name ⇨ [Parameter]

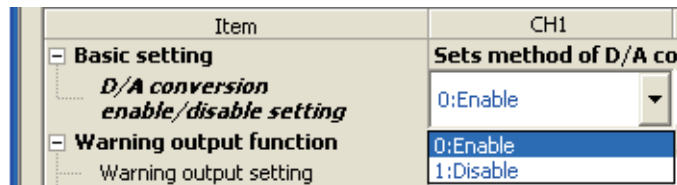

#### 2. Set "Warning output function" to "0: Enable".

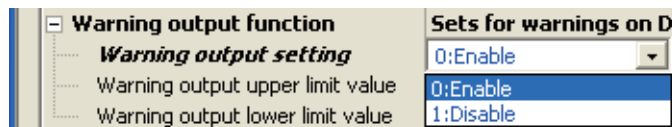

#### 3. Set a value for "Warning output upper limit value" and "Warning output lower limit value".

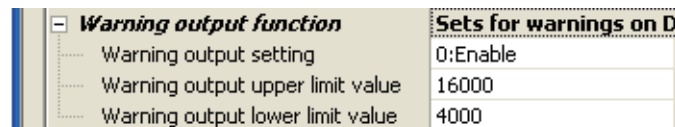

Item	Setting range
Warning output upper limit value	-32768 to 32767
Warning output lower limit value	

## 8.7 Error Log Function

This function stores a history of errors and alarms that occurred in the D/A converter module to the buffer memory (Un\G1810 to Un\G1969).

A maximum of 16 errors and alarms can be stored.

### (1) Process of the error log function

The error code and the time of error occurrence are stored in the buffer memory address, starting from error history No.1 (start address Un\G1810) and sequentially thereafter.

### (2) Checking error history

You can check the start address of the latest stored error at Latest error code address (Un\G1800)

**Ex.** 1. When the third error occurs:

The third error is stored in error history No.3, and the value "1830" (start address of error history No.3) is stored to Latest error code address (Un\G1800).

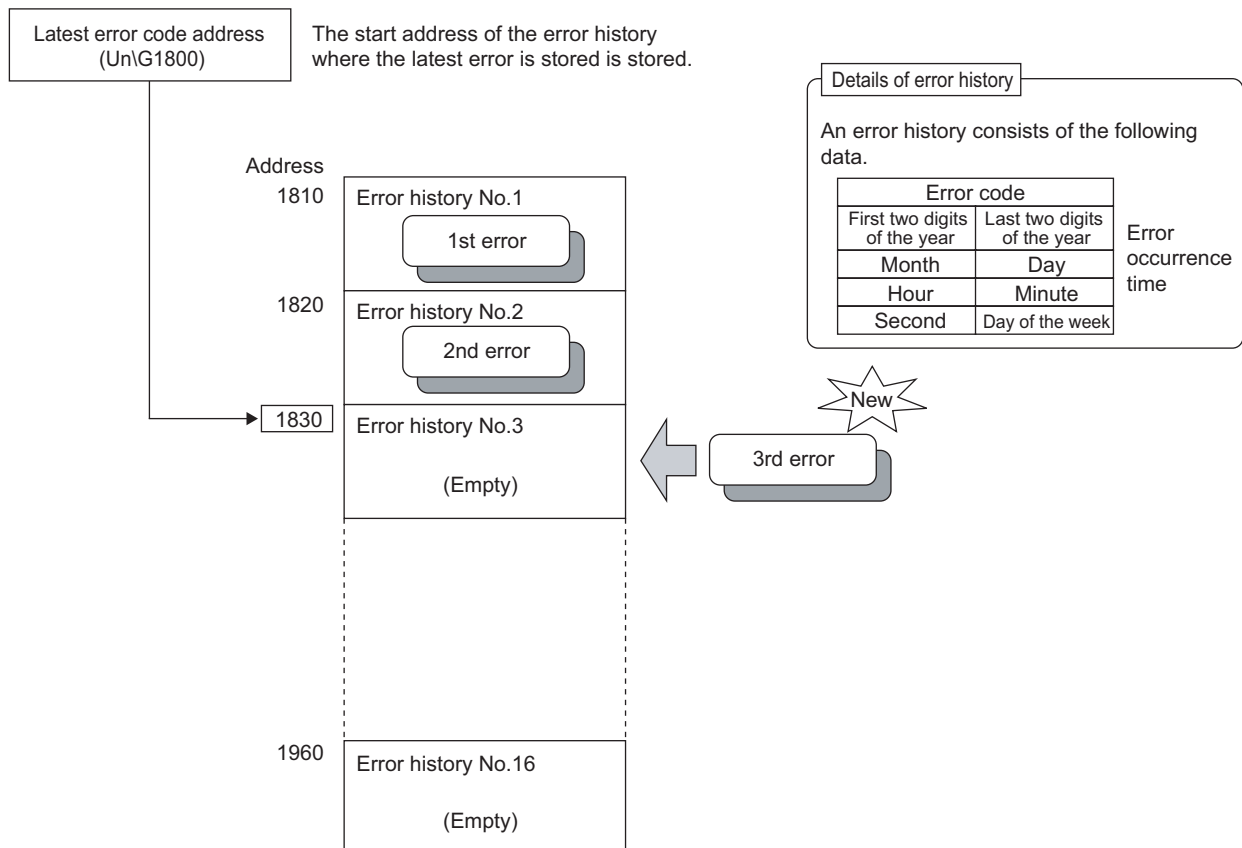

**Ex.** 2. When the 17th error occurs:

The 17th error is stored in error history no.1, and the value "1810" (start address of error history No.1) is stored to Latest error code address (Un\G1800).

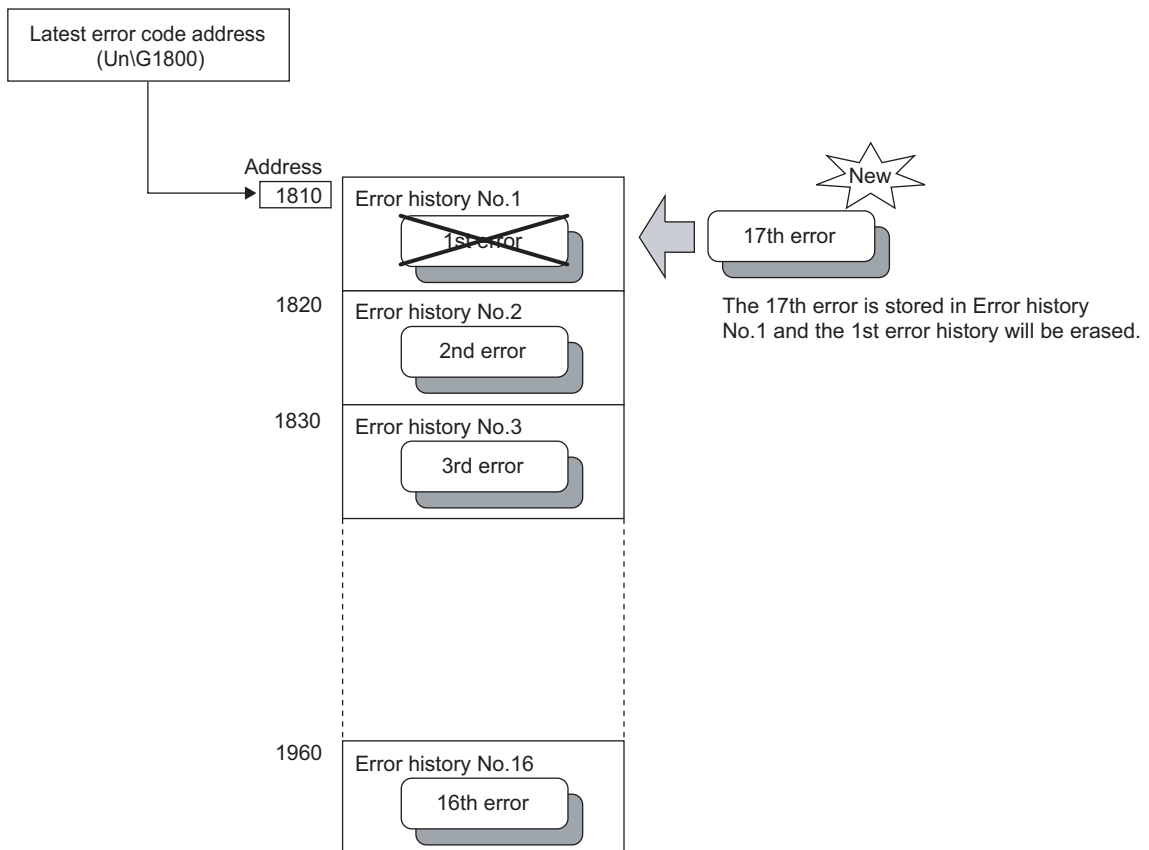

### Point

- The same process for errors is used when an alarm occurs.
- Once the error history storage area becomes full, subsequent errors will overwrite the previous errors, starting from error history No.1, and continues sequentially thereafter (Un\G1810 to G1819). (The overwritten history is deleted.)
- The stored error history is cleared when power supply is turned OFF, or when the CPU module is reset.



# 8.8 Module Error Collection Function

This function collects the errors and alarms occurred in D/A converter module into the CPU module or the head module. By holding the module errors in a memory that can hold data in the event of power failure, the errors can be held even after powering off or resetting the CPU module or the head module.

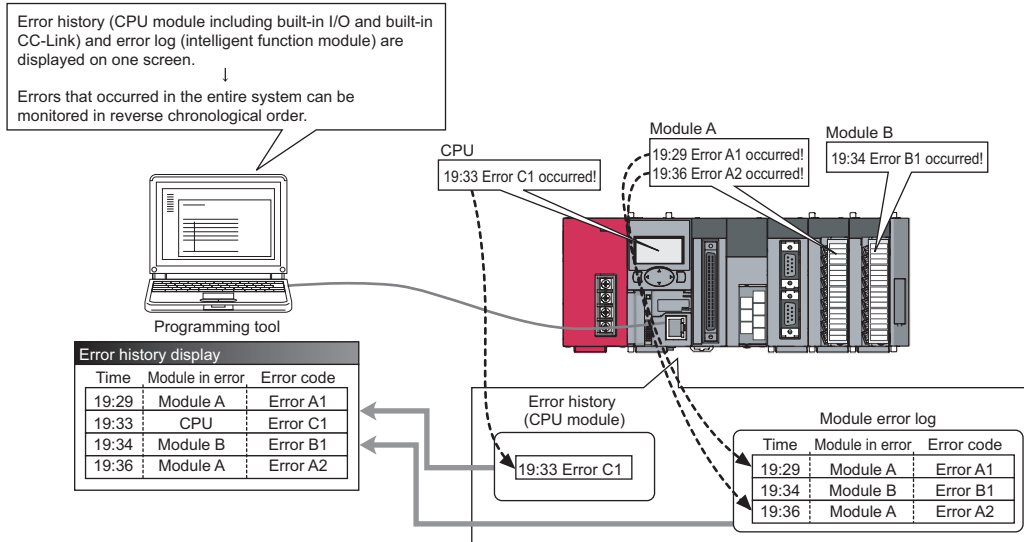

[Example of screen display]

No.	Error Code	Date and Time	Model Name	Start I/O
00125	0070	2009/12/10 17:02:37	L60AD4	0030
00124	0070	2009/12/10 17:00:05	L60AD4	0030
00123	0CE4	2009/12/10 17:00:04	L26CPU-BT	----
00122	05DC	2009/12/10 16:15:50	L26CPU-BT	----
00121	0070	2009/12/10 15:59:30	L60DA4	0030
00120	0070	2009/12/10 15:45:02	L60DA4	0010
00119	05DC	2009/12/10 14:14:38	L26CPU-BT	----
00118	0070	2009/12/10 14:12:03	L60DA4	0010
00117	0CE4	2009/12/10 13:59:54	L26CPU-BT	----
00116	0CE4	2009/12/10 13:35:11	L26CPU-BT	----
00115	05DC	2009/12/10 11:11:45	L26CPU-BT	----
00114	0070	2009/12/10 11:07:05	L60AD4	0010
00113	0CE4	2009/12/10 11:07:04	L26CPU-BT	----
00112	0070	2009/12/10 11:03:49	L60AD4	0010
00111	0CE4	2009/12/10 11:03:48	L26CPU-BT	----
00110	05DC	2009/12/09 16:30:58	L26CPU-BT	----
00109	0070	2009/12/09 16:29:33	L60DA4	0010
00108	0070	2009/12/09 16:29:12	L60DA4	0010
00107	083B	2009/12/09 16:29:11	L26CPU-BT	----

**Point**

For details on the module error collection, refer to the following.

- MELSEC-L CPU Module User's Manual (Function Explanation, Program Fundamentals)
- MELSEC-L CC-Link IE Field Network Head Module User's Manual

## 8.9 Error Clear Function

When an error occurs, you can clear the error from the system monitor.

By clicking the **Error Clear** button in the system monitor, the latest error code stored in Latest error code (Un\G19)

is cleared and the ERR. LED is also turned off. The operation is the same as Error clear request (YF) as well as executing error clear from the display unit.

However, error history cannot be cleared.

For instructions on error clear request and executing error clear from the display unit, refer to the following.

- Error clear request (YF) (☞ Page 98, Appendix 1)
- Checking/Clearing an Error (☞ Page 75, Section 9.4)

☞ [Diagnostics] ⇄ [System Monitor...] ⇄ error module

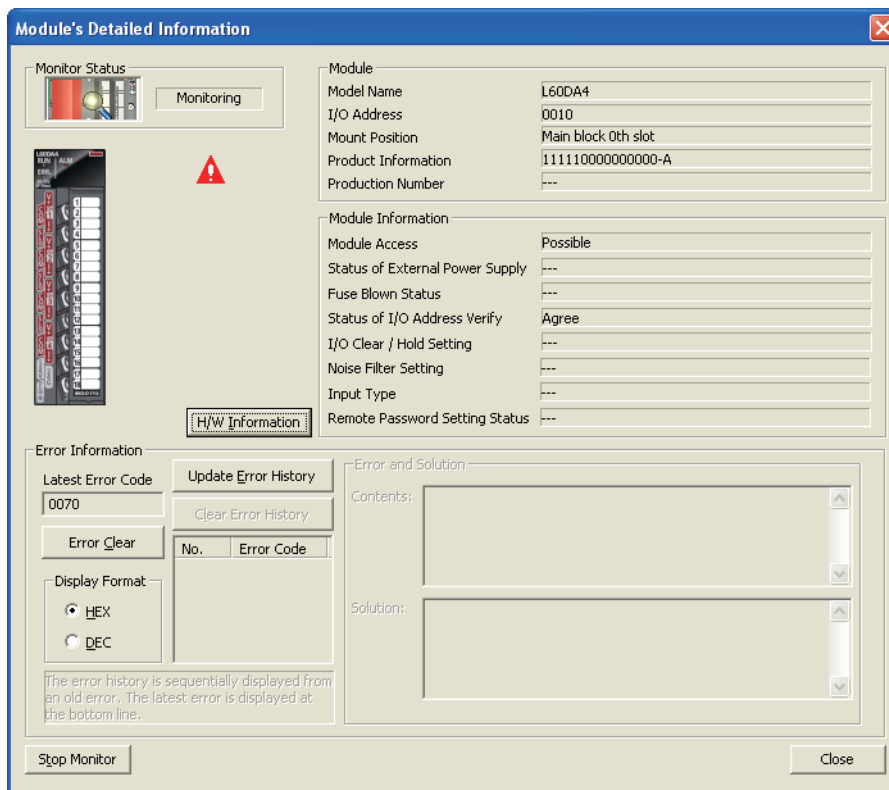

## 8.10 Saving and Restoring Offset/Gain Values

The D/A converter module can save and restore the offset/gain values in the user range setting.

When replacing a module in case of failure, this function enables to pass the offset/gain value from a module to be changed (disconnected) to the newly-connected CPU module.

If multiple D/A converter modules are installed in the same system, this function enables to apply the offset/gain value set to one module to the other modules.

However, if you save and restore the offset/gain values, the accuracy after the restoration decreases by approximately three times compared to that before the restoration.

Reconfigure the offset/gain as necessary.

### (1) Procedure for saving and restoring offset/gain values

(a) To restore offset/gain values onto a new replacement module:

1. Save the offset/gain values.

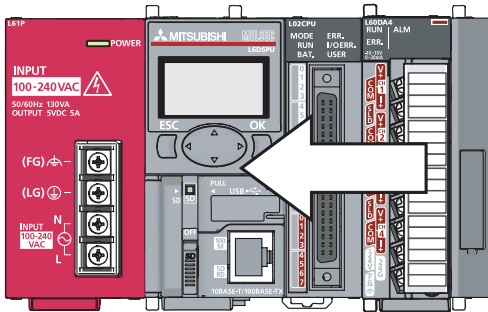

2. Replace the D/A converter module.

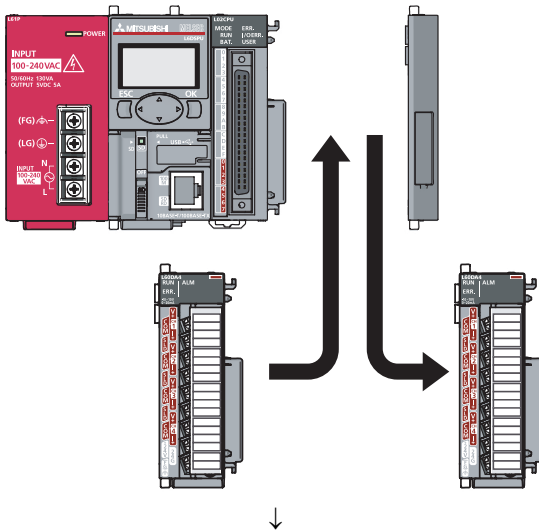

3. Restore the offset/gain values.

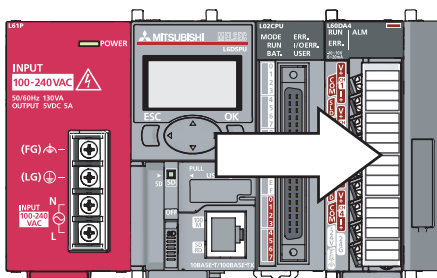

**(b) To apply the offset/gain values of one module to the other modules in the same system:**

**Ex.** Here, the offset/gain setting of module No.1 is applied to modules No.2 to No.4.

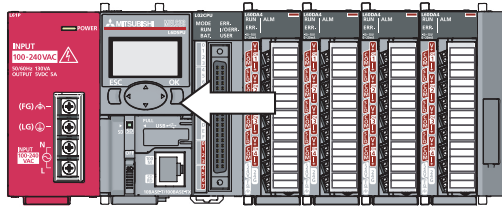

**1. Save the offset/gain values of module No.1.**

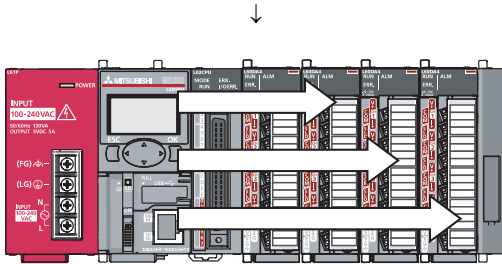

**2. Apply the offset/gain values to modules No.2 to No.4.**

## (2) Methods for saving and restoring offset/gain values

There are two methods for saving and restoring offset/gain values.

- Saving and restoring by dedicated instructions
- Saving and restoring by reading from and writing to the buffer memory

### (a) Saving and restoring by dedicated instructions

Temporarily save the offset/ gain value in the source D/A converter module into the internal device of CPU module using G(P).OGLOAD of dedicated instruction. Then, write the data to the restoring target D/A converter module using G(P).OGSTOR.

You can prevent the saved offset/gain value data from getting deleted, by doing one of the following before replacing the modules:

- Use latch settings for the internal device of the destination module.
- Save the data onto an SD card
  - To write data: use SP.FWRITE instruction
  - To read data: use SP.FREAD instruction
- Store the saved data

For use of dedicated instructions, refer to the following.

- Dedicated Instructions (👉 Page 115, Appendix 5)

### Point

When performing the dedicated instruction G(P).OGSTOR, the D/A conversion is stopped.  
Turn OFF → ON → OFF Operating condition setting request (Y9) to restart the D/A conversion.

**(b) Saving and restoring by reading from and writing to the buffer memory**

In the buffer memory, use Pass data classification setting (Un\G200), CH1 Industrial shipment settings offset value (Un\G202) to CH4 User range settings gain value (Un\G217) and User range writing request (YA) to read the offset/gain values from the source D/A converter module, then use the buffer memory again to write to the destination D/A converter module.

The procedure for using the buffer memory is described below.

- To restore offset/gain values onto a new replacement module:

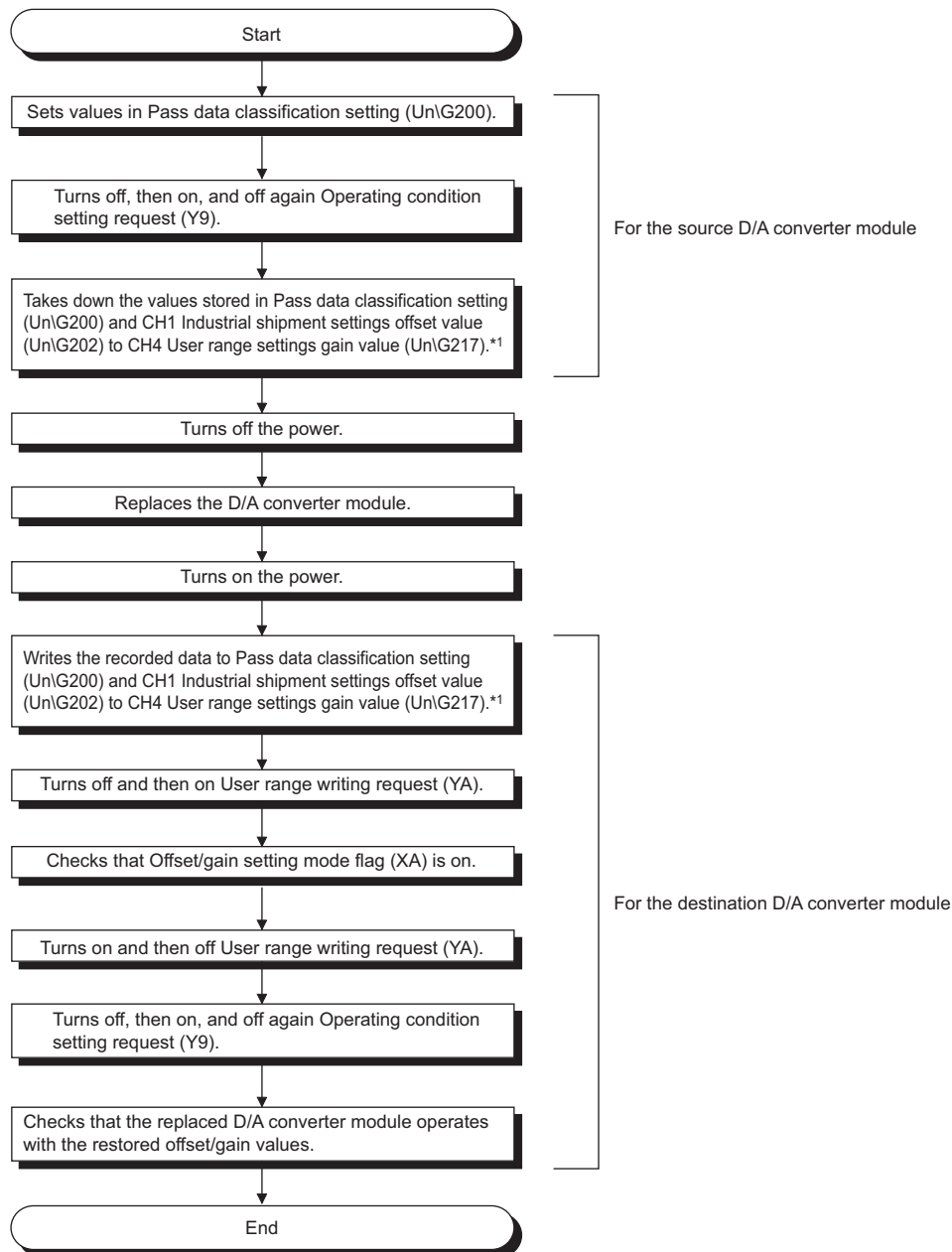

\*1 When replacing modules, you can prevent the saved offset/gain value data from getting deleted, by doing one of the following before turning the power off:

- Use latch settings for the internal device of the destination module.
- Save the data onto an SD card.
  - To write data: use SP.FWRITE instruction
  - To read data: use SP.FREAD instruction
- Store the saved data.

- To apply the offset/gain values of one module to the other modules:

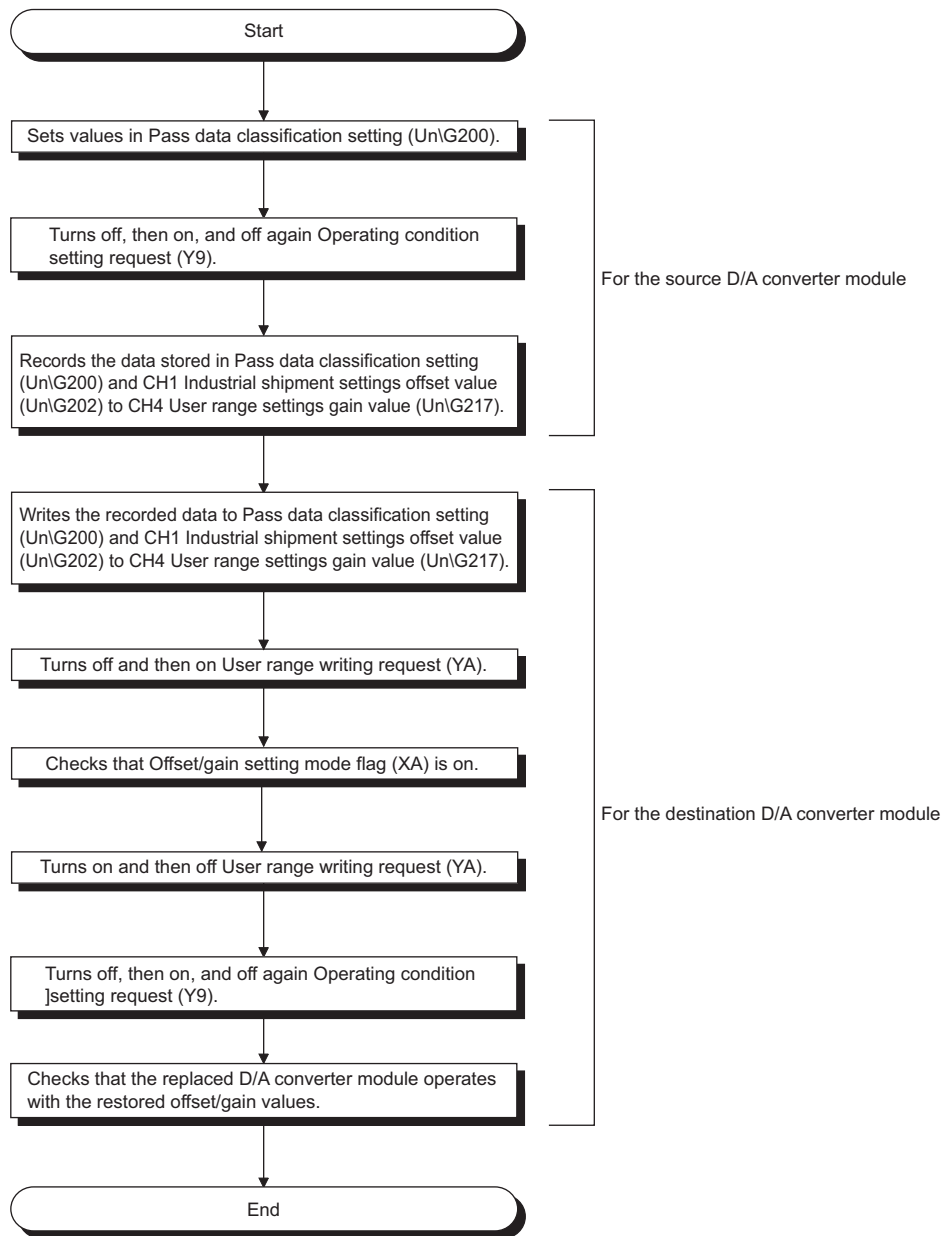

### Point!

When the data is written to the following buffer memory address in the source D/A converter module and User range writing request (YA) is turned from OFF to ON, the D/A conversion is stopped.

- Pass data classification setting (Un\G200)
- CH1 Industrial shipment settings offset value (Un\G202) to CH4 User range settings gain value (Un\G217)

Turn OFF → ON → OFF Operating condition setting request (Y9) to restart the D/A conversion.

### (3) Range reference tables

Below are reference ranges to be used for saving and restoring offset/gain values.

#### (a) Reference table for CH1 Industrial shipment settings offset value (Un\G202) to CH4 Industrial shipment settings gain value (Un\G209)

The reference values will vary depending on the Pass data classification setting (Un\G200) (voltage or current).

Address (decimal)				Description	Pass data classification setting	Reference value (hexadecimal)
CH1	CH2	CH3	CH4			
202	204	206	208	Industrial shipment settings offset value	Voltage	Approx. 8000 <sub>H</sub>
					Current	Approx. 8000 <sub>H</sub>
203	205	207	209	Industrial shipment settings gain value	Voltage	Approx. F712 <sub>H</sub>
					Current	Approx. F166 <sub>H</sub>

#### (b) Reference table for CH1 User range settings offset value (Un\G210) to CH4 User range settings gain value (Un\G217)

Offset/gain value		Reference value (hexadecimal)
Voltage	0V	Approx. 8000 <sub>H</sub>
	1V	Approx. 8BE8 <sub>H</sub>
	5V	Approx. BB89 <sub>H</sub>
	10V	Approx. F712 <sub>H</sub>
Current	0mA	Approx. 8000 <sub>H</sub>
	4mA* <sup>1</sup>	Approx. 96AE <sub>H</sub>
	20mA* <sup>2</sup>	Approx. F166 <sub>H</sub>

\*1 This is the value that is stored in user range settings offset value at the time of shipping.

\*2 This is the value that is stored in user range settings gain value at the time of shipping.

# CHAPTER 9 DISPLAY UNIT

This chapter describes the functions of the display unit that can be used in D/A converter module. For instruction on operating the display unit, or for details on the functions and menu configuration, refer to the following.

 MELSEC-L CPU Module User's Manual (Function Explanation, Program Fundamentals)

## 9.1 Display Unit

The display unit is an LCD to be attached to the CPU module. By attaching the display unit to the CPU module, you can check the status of the system and change system settings without the software package. In addition, in the event a problem occurs, you can identify the cause of the problem by displaying the error information on the display unit. For details on how to check and clear an error from the display unit, refer to the following.

- Check/clear error ( Page 75, Section 9.4)

## 9.2 Menu Structure

### (1) Organization

The diagram below shows how the "MOD MON/TEST" menu and "MOD SETTINGS" are organized.

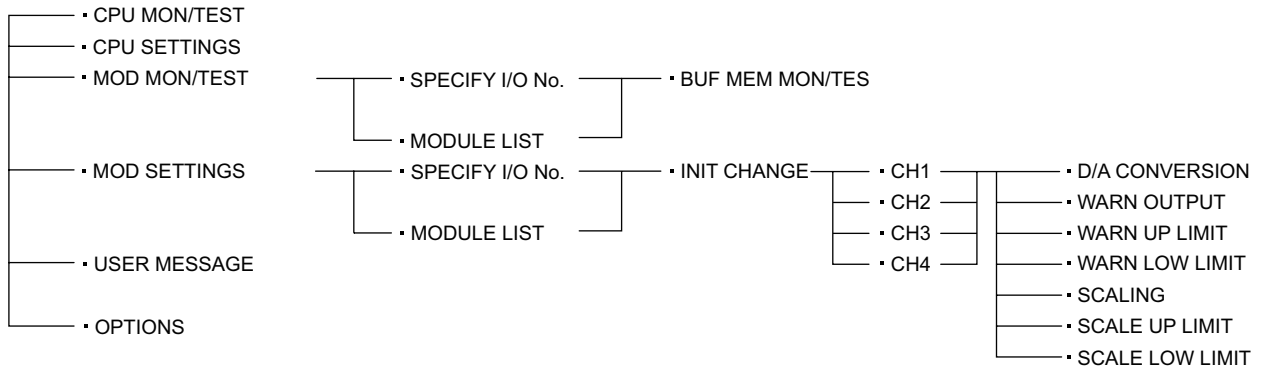



## (2) Screen transitions up to the initial setting change screen

The diagram below shows how the screens transition to the initial setting change screen.

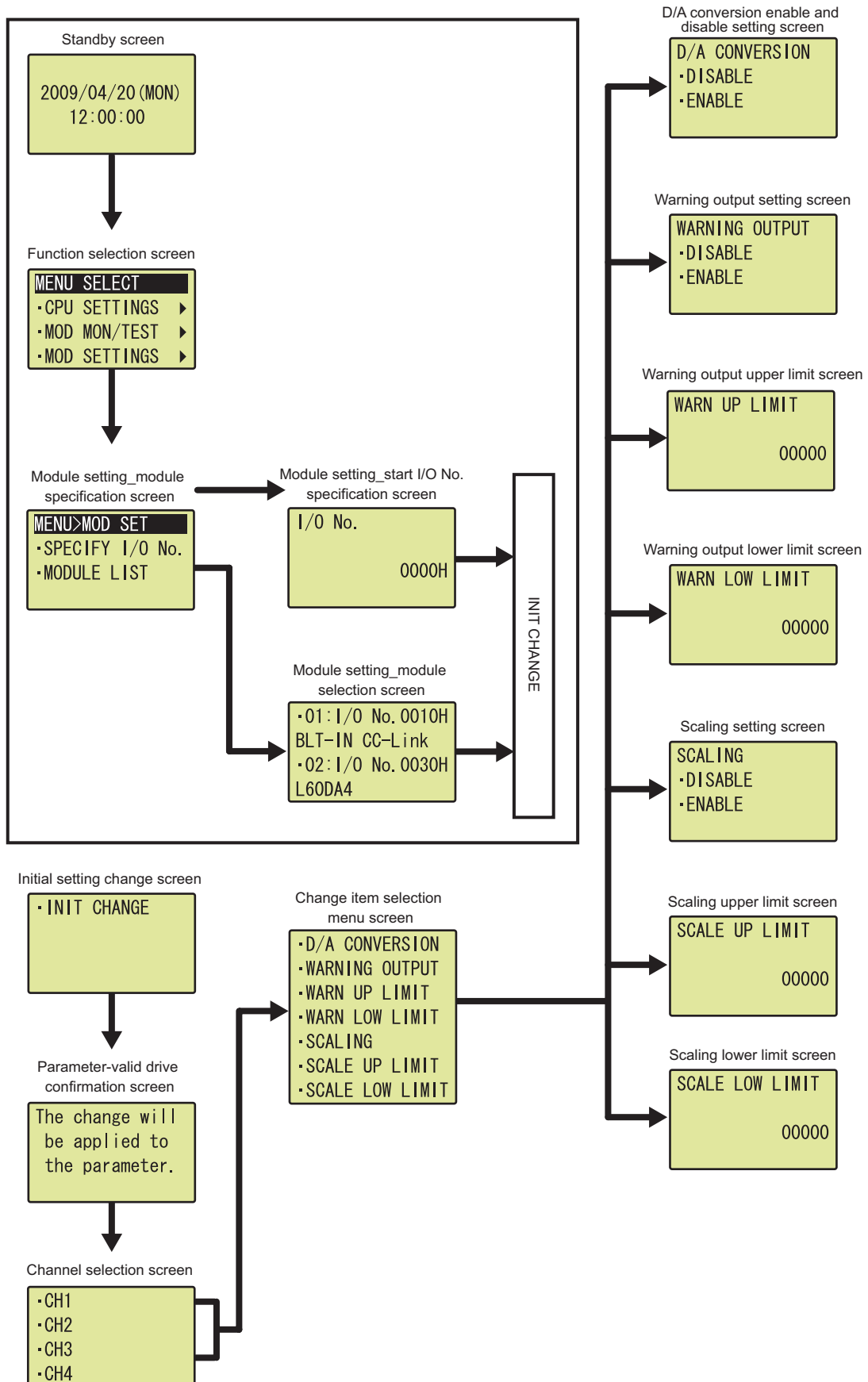

## 9.3 List of Setting Value Change Screens

---

The following is a list of setting value change screens.

### (1) Displayed in English:

Name		Screen format	Input regulation	
Setting item	Screen display		Upper limit value	Lower limit value
D/A conversion enable/disable setting	D/A CONVERSION	Selection	—	—
Warning output setting	WARNING OUTPUT	Selection	—	—
Warning output upper limit value	WARN UP LIMIT	Numeric value	32767	-32768
Warning output lower limit value	WARN LOW LIMIT	Numeric value	32767	-32768
Scaling enable/disable setting	SCALING	Selection	—	—
Scaling upper limit value	SCALE UP LIMIT	Numeric value	32000	-32000
Scaling lower limit value	SCALE LOW LIMIT	Numeric value	32000	-32000

## (2) D/A CONVERSION

Select "DISABLE" or "ENABLE" in the "D/A conversion enable/disable conversion" screen.

"D/A conversion enable/disable conversion" screen

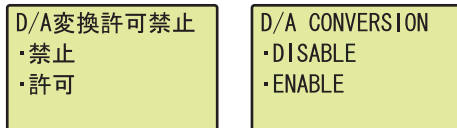

1. Use the ▲ and ▼ buttons to select "DISABLE" or "ENABLE", and then confirm with the **OK** button.

## (3) Warning output setting

Select "DISABLE" or "ENABLE" on the "Warning output setting" screen.

"Warning output setting" screen

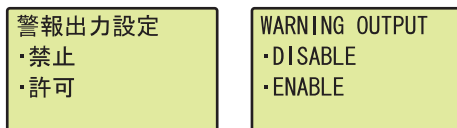

"Warning output upper limit" screen

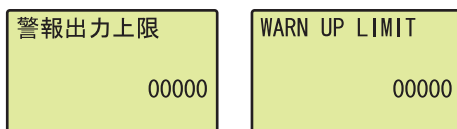

"Warning output lower limit" screen

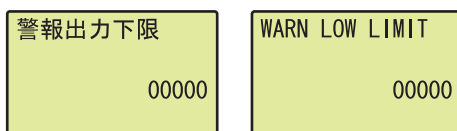

1. Use the ▲ and ▼ buttons to select "DISABLE" or "ENABLE", and then confirm with the **OK** button. (If you selected "ENABLE", follow the rest of the procedure.)
2. Move the cursor using the ◀ and ▶ buttons, then increment or decrement the value at the cursor, using the ▲ and ▼ buttons, respectively. Confirm with the **OK** button.
3. Move the cursor using the ◀ and ▶ buttons, then increment or decrement the value at the cursor, using the ▲ and ▼ buttons, respectively. Confirm with the **OK** button.

Table of input items

Input item	Input range	
	Input upper limit	Input lower limit
WARN UP LIMIT	32767	-32768
WARN LOW LIMIT		

## (4) SCALING

Select "DISABLE" or "ENABLE" in the "Scaling setting" screen.

"Scaling setting" screen

スケーリング 設定 ・無効 ・有効	SCALING ・DISABLE ・ENABLE
-------------------------	--------------------------------



"Scaling upper limit" screen

スケーリング 上限  00000	SCALE UP LIMIT  00000
------------------------	-----------------------------



"Scaling lower limit" screen

スケーリング 下限  00000	SCALE LOW LIMIT  00000
------------------------	------------------------------

1. Use the ▲ and ▼ buttons to select "DISABLE" or "ENABLE", and then confirm with the  button. (If you selected "ENABLE", follow the rest of the procedure.)
2. Move the cursor using the ◀ and ▶ buttons, then increment or decrement the value at the cursor, using the ▲ and ▼ buttons, respectively. Confirm with the  button.
3. Move the cursor using the ◀ and ▶ buttons, then increment or decrement the value at the cursor, using the ▲ and ▼ buttons, respectively. Confirm with the  button.

Table of input items

Input item	Input range	
	Input upper limit	Input lower limit
SCALE UP LIMIT	32000	-32000
SCALE LOW LIMIT		

## 9.4 Checking and Clearing Errors

You can check the errors that occurred in the D/A converter module, from the display unit. In addition, you can also clear an error during its occurrence.

### (1) Checking errors

You can check the error that occurred in the D/A converter module, by specifying Latest error code (Un\G19) from "buffer memory monitor/test".

**Ex.** When an error occurs in the D/A converter module with a start I/O number of 1

"Buffer memory monitor/test" screen

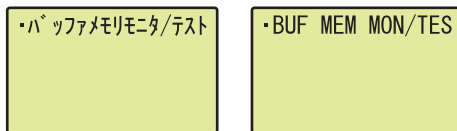

↓

"Buffer memory address input format selection" screen

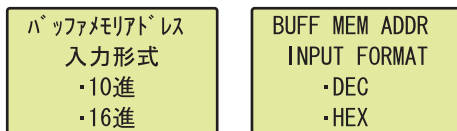

↓

"Buffer memory address setting" screen

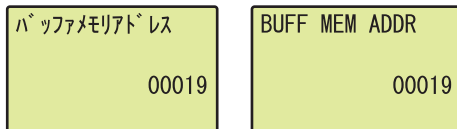

↓

"Buffer memory monitor" screen

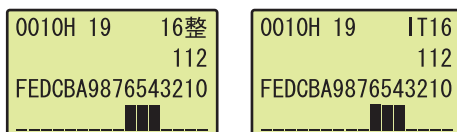

**1.** Press the **OK** button.

**2.** Use the **▲** and **▼** buttons to select "DEC" for the input format of the buffer memory address, and then confirm with the **OK** button.

**3.** Move the cursor using the **◀** and **▶** buttons, then increment or decrement the value at the cursor, using the **▲** and **▼** buttons, respectively. Confirm with the **OK** button.

**4.** You can check the error that occurred, in the "Buffer memory monitor" screen.

## (2) Clearing errors

You can clear an error by eliminating the cause of the error, and turning Error clear request (YF) OFF → ON → OFF from "Device Monitor/Test".

**Ex.** When an error occurs in the D/A converter module with a start I/O number of 1

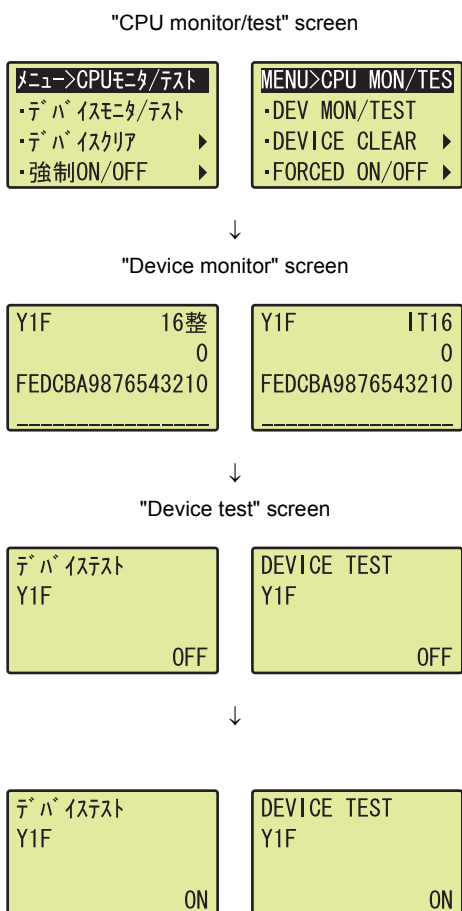

**1.** Use the ▲ and ▼ buttons to select "DEV MON/TEST", and then confirm with the **OK** button.

**2.** Set the device to Y and press the **OK** button.

**3.** Use the ▲ and ▼ buttons to set the device to Y1F, and then confirm with the **OK** button.

**4.** Use the ▲ and ▼ buttons to switch ON/OFF. Press the **OK** button to set the value at the device test setting.

# CHAPTER 10 PROGRAMMING

This chapter describes the procedure for programming and the basic program of the D/A converter module.

## 10.1 Procedure for Programming

Create a program executed by D/A converter module according to the following procedure.

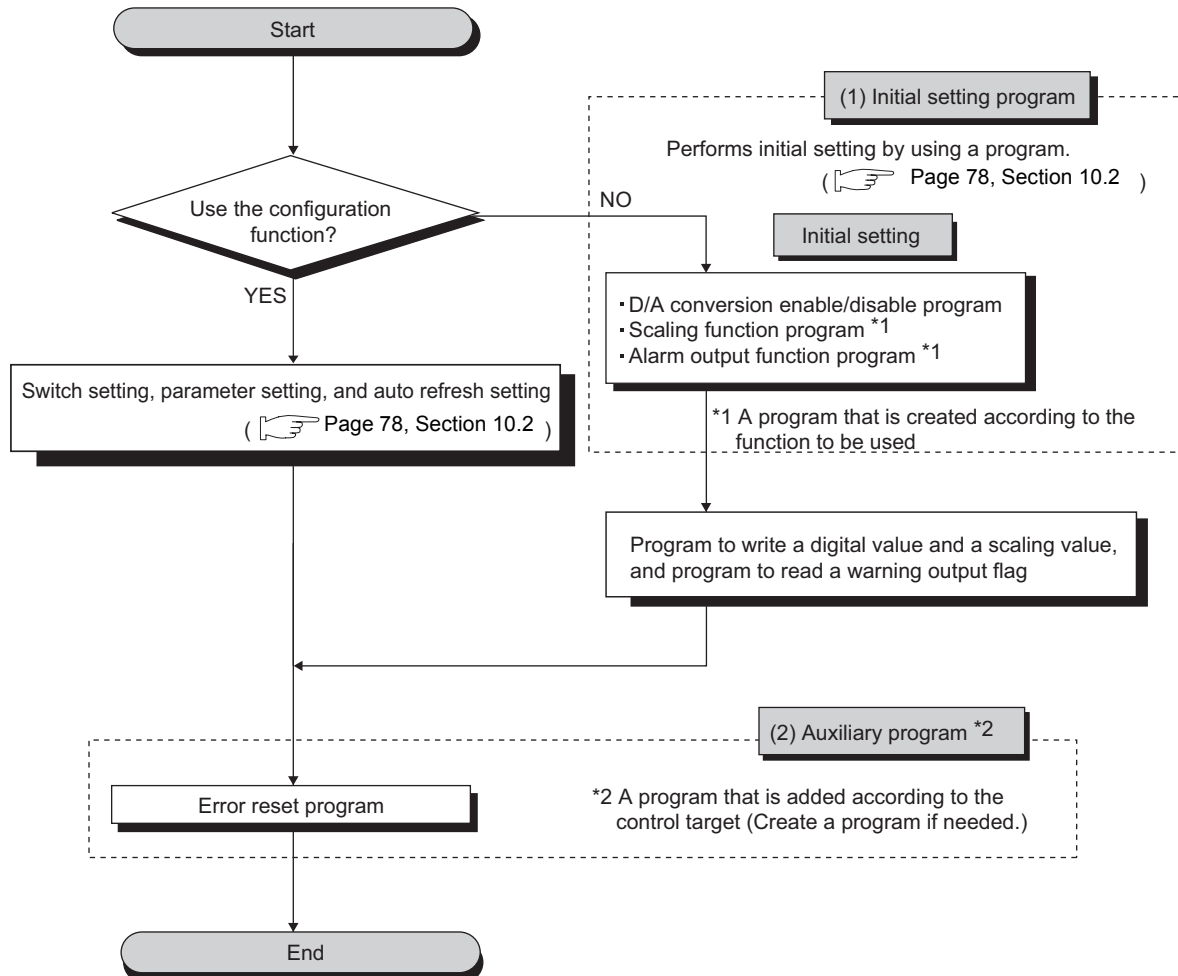

## 10.2 When Using a Standard System Configuration

---

The following shows program examples for the system configuration and usage conditions of the D/A converter module.

### (1) System configuration

The following shows an example of the system configuration when using the module in a standard system configuration.

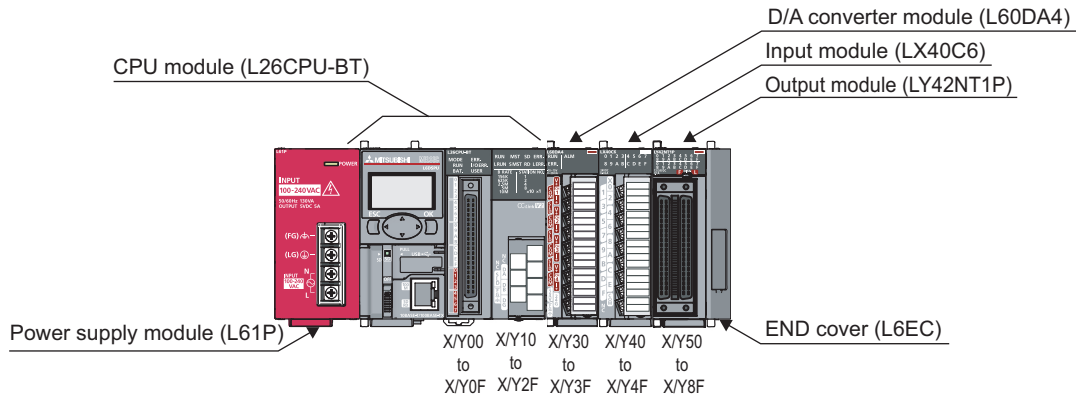

### Point

For configuring the same I/O assignment as the system above, when using the L02CPU, set I/O Assignment of the D/A converter module within X/Y30 to X/YF. Also, set the I/O assignment of the LX40C6 within X/Y40 to X/Y4F, and the same of the LY42NT1P, within X/Y50 to X/Y8F.

---

### (2) Programming condition

Set CH1 and CH2 of the D/A converter module to D/A conversion enabled, and then write the digital values. If a digital value write error occurs, an error code is displayed in BCD. Configure the scaling setting in CH1 only, and configure the warning output function in CH2 only.



### (3) Switch Setting

Set the output range, HOLD/CLEAR function and operation mode.

Project window ⇨ [Intelligent Function Module] ⇨ module name ⇨ [Switch Setting]

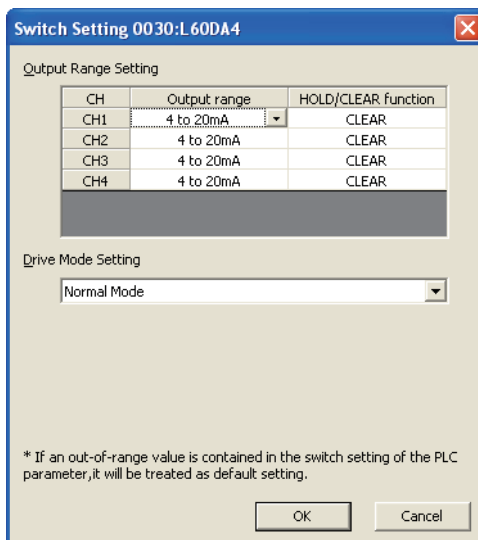

### (4) Initial setting description

#### (a) Channel setting

Setting item	CH1	CH2	CH3	CH4
D/A conversion enable/disable setting	Enable	Enable	Disable	Disable
Warning output setting	Disable	Enable	Disable	Disable
Warning output lower limit value	–	3000	–	–
Warning output upper limit value	–	10000	–	–
Scaling enable/disable setting	Enable	Disable	Disable	Disable
Scaling upper limit value	32000	–	–	–
Scaling lower limit value	0	–	–	–

#### (b) Devices for users

Device	Description	
D1	CH1 digital value	
D2	CH2 digital value	
D8	Warning output flag	
D10	Error code	
D11	CH1 Scaling value	
M20 to 27	Warning output flag	
M100	Module READY checking flag	
X41	Batch output enable signal	LX40C6 (X40 to X4F)
X42	Digital value write command input signal	
X44	Alarm output reset signal	
X45	Error reset signal	
Y50 to 5F	Error code notation (BCD 4 digits)	LY42NT1P (Y50 to Y5F)

## (5) Program example when using the parameter of intelligent function module

### (a) Parameter setting

Set the contents of initial settings in the parameter.

Project window ⇨ [Intelligent Function Module] ⇨ module name ⇨ "Parameter"

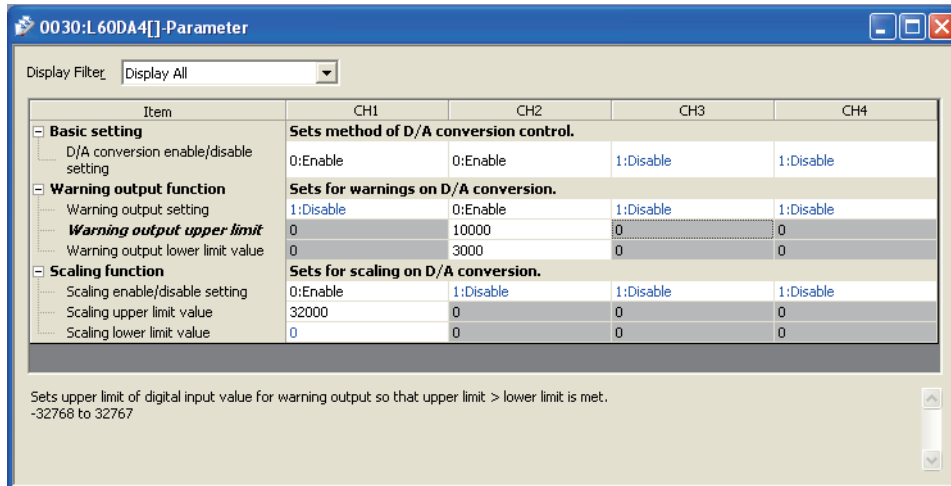

### (b) Auto refresh setting

Project window ⇨ [Intelligent Function Module] ⇨ module name  
⇨ [Auto\_Refresh]

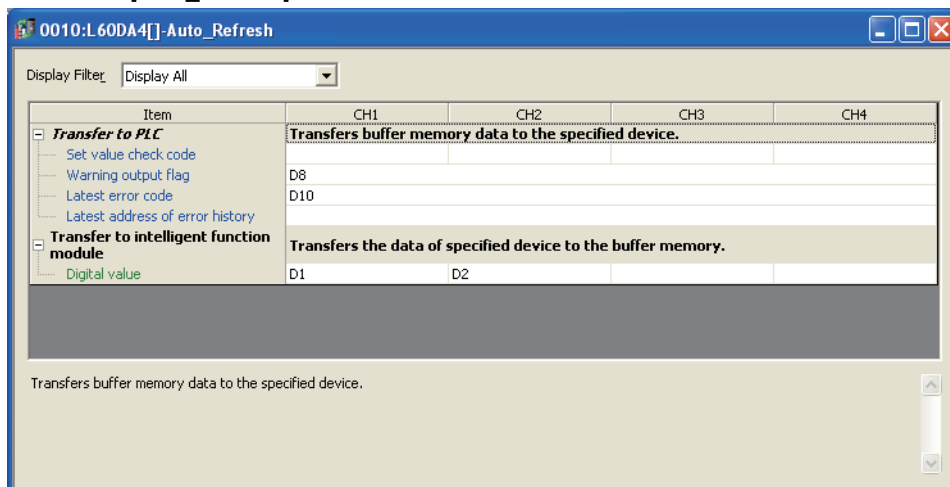

### (c) Writing the parameter of intelligent function module

Write the set parameter to the CPU module and reset the CPU module, or then off and then on the programmable controller power supply.

[Online] ⇨ [Write to PLC]

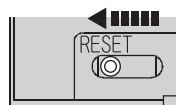

or Power OFF → ON

(d) Program example

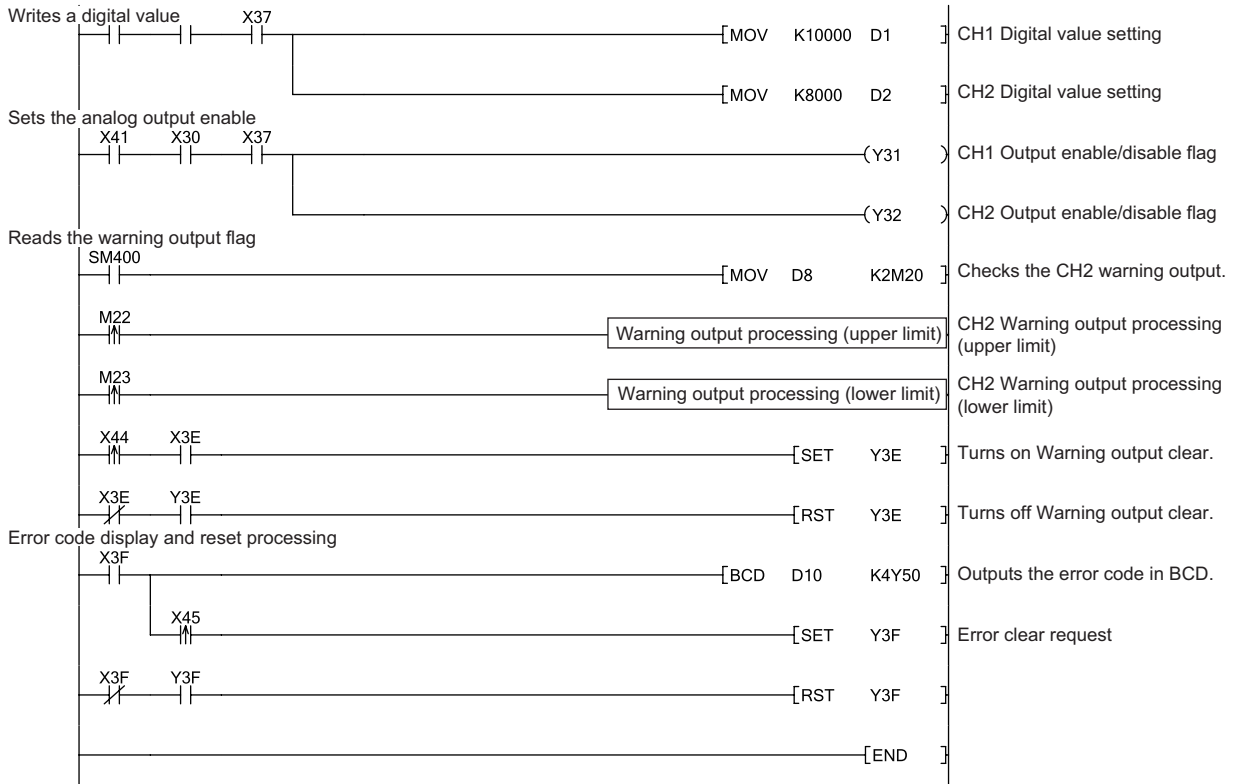

## (6) Program example when not using the parameter of intelligent function module

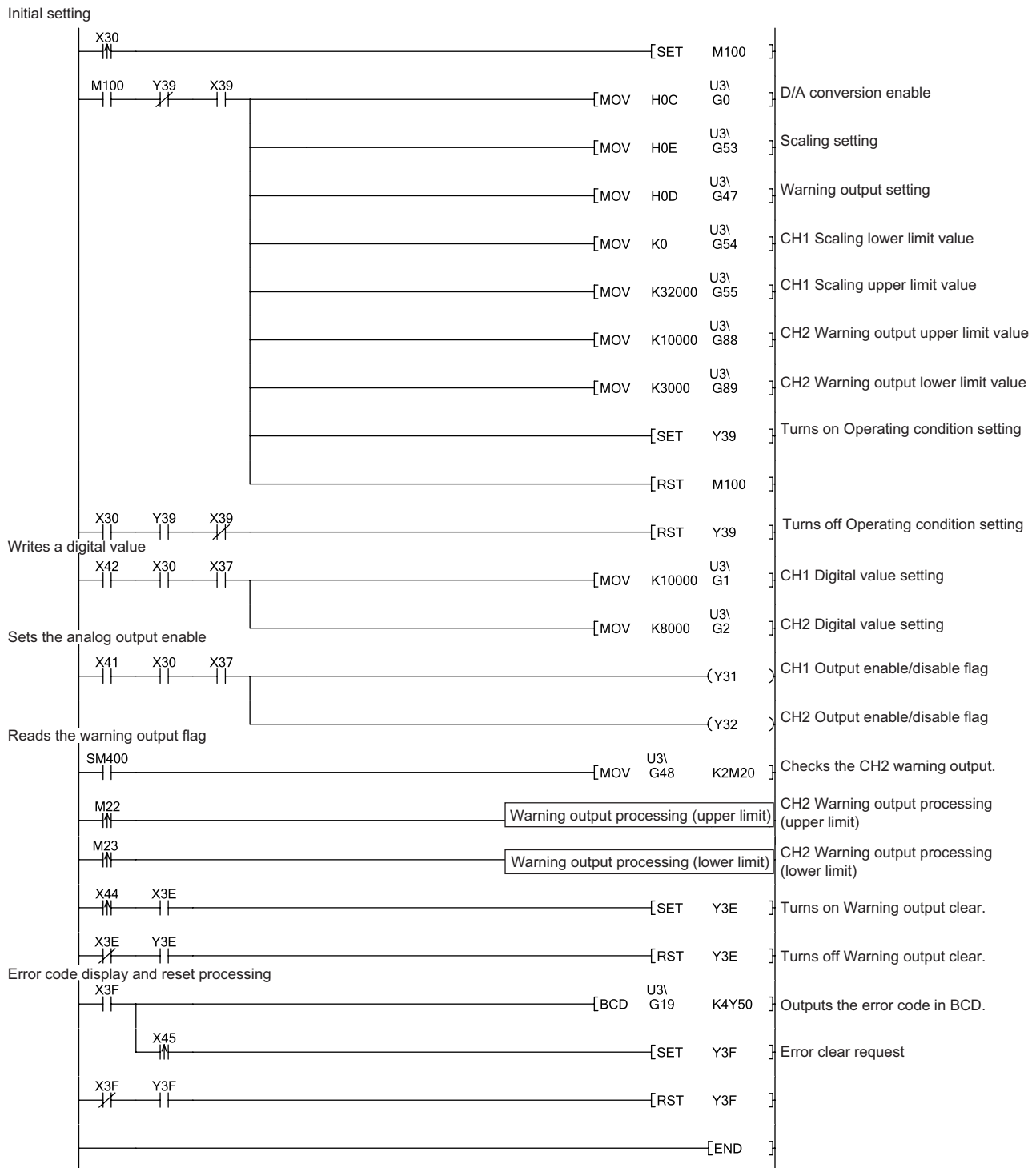

## 10.3 When D/A Converter Module is Connected to Head Module

This section describes system configuration of the D/A converter module and a program example of operation condition.

### (1) System configuration

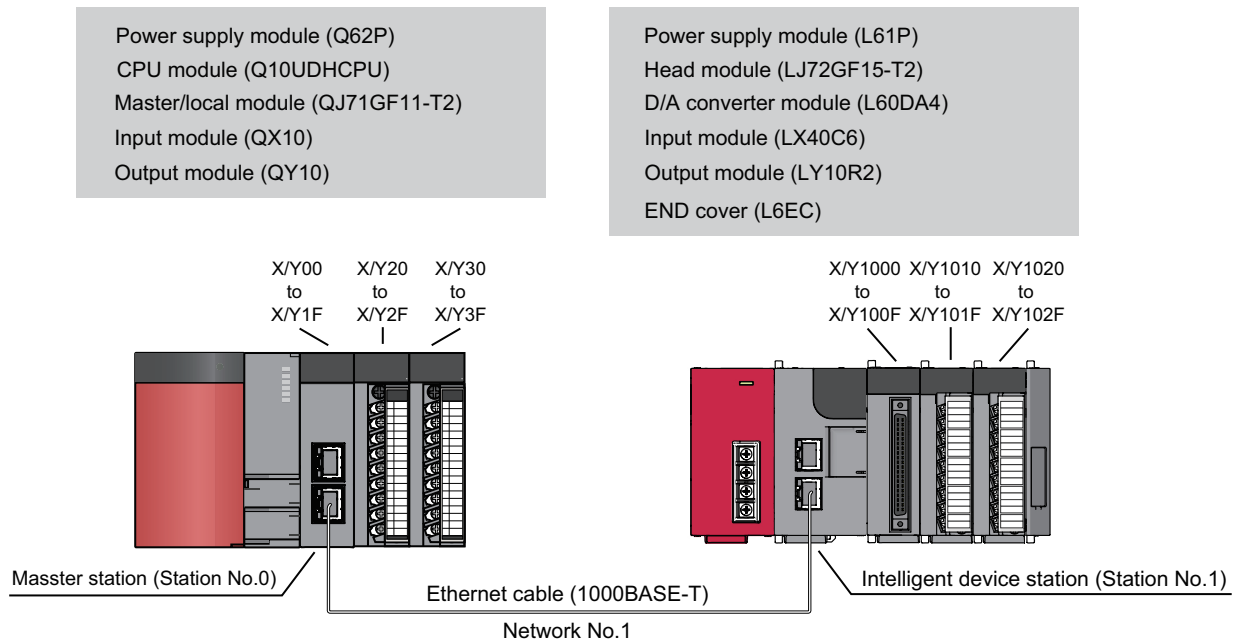

### (2) Programming conditions

This section describes the example of outputting analog values by setting CH1 and CH2 of the D/A converter module to D/A conversion enabled.

When a write error of digital value occurs, the error code is displayed in BCD.

Scaling setting is configured only for CH1 and warning output function only for CH2.

### (3) Description of initial setting

Setting items	CH1	CH2	CH3	CH4
D/A conversion enable/disable setting	Enabled	Enabled	Disabled	Disabled
Warning output function	Disabled	Enabled	Disabled	Disabled
Warning output upper limit value	–	10000	–	–
Warning output lower limit value	–	3000	–	–
Scaling enable/disable setting	Enabled	Disabled	Disabled	Disabled
Scaling upper limit value	32000	–	–	–
Scaling lower limit value	0	–	–	–

#### (4) Devices used by a user

Device	Description	
W1	CH1 Digital value	
W2	CH2 Digital value	
W1008	Warning output flag	
W1010	Latest error code	
M20 to M27	Warning output flag	
X21	Batch output enable signal	QX10 (X20 to X2F)
X22	Digital value write command input signal	
X24	Warning output reset signal	
X45	Error reset signal	
Y30 to Y3F	Error code display (BCD 4 digits)	QY10 (Y30 to Y3F)
SB49	Data link status (own station)	
SWB0.0	Data link status (each station) (station number 1)	
N0	Nesting (station number 1)	
M0	Flag for meeting the communication condition (station number 1)	

#### (5) Setting on master station

##### 1. Create a project on GX Works2.

Select "QCPU (Q mode)" for "PLC Series" and select "Q10UDH" for "PLC Type."

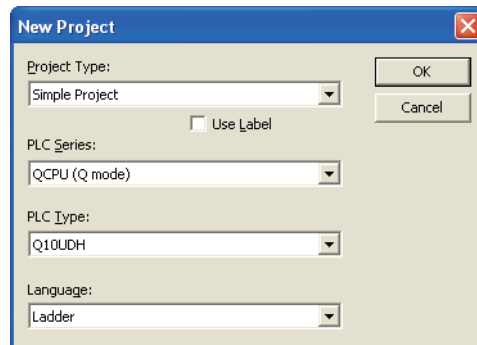

##### 2. Display the network parameter setting screen and configure the setting as follows.

Project window ⇒ [Parameter] ⇒ [Network Parameter]  
 ⇒ [Ethernet/CC IE/MELSECNET]

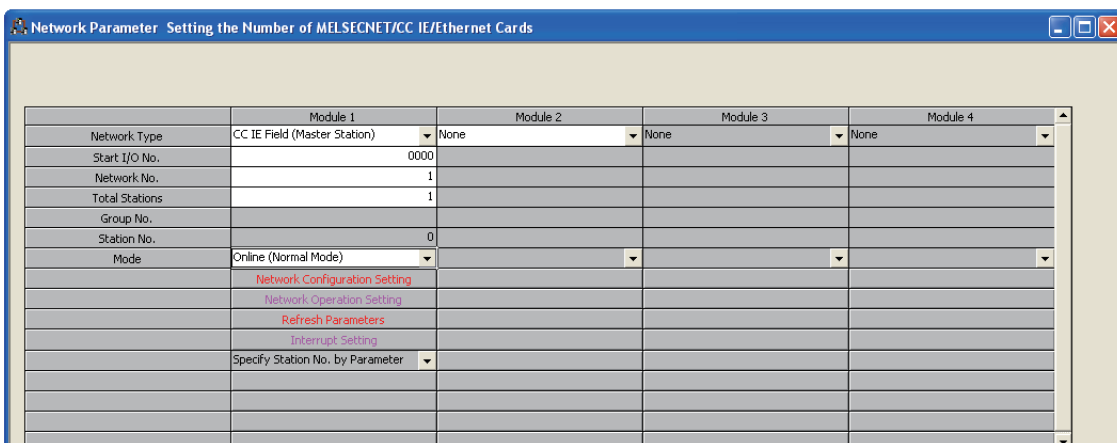

**3. Display the Network Configuration Setting screen and configure the setting as follows.**

- ☞ Project window ⇒ [Parameter] ⇒ [Network Parameter]
- ☞ [Ethernet/CC IE/MELSECNET] ⇒  button

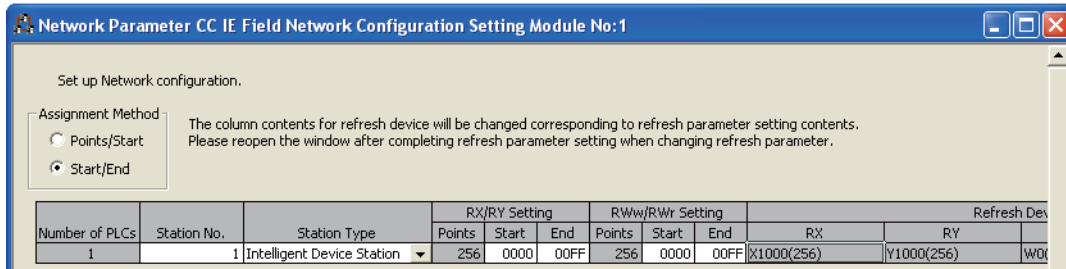

**4. Display the Refresh Parameter setting screen and configure the setting as follows.**

- ☞ Project window ⇒ [Parameter] ⇒ [Network Parameter]
- ☞ [Ethernet/CC IE/MELSECNET] ⇒  button

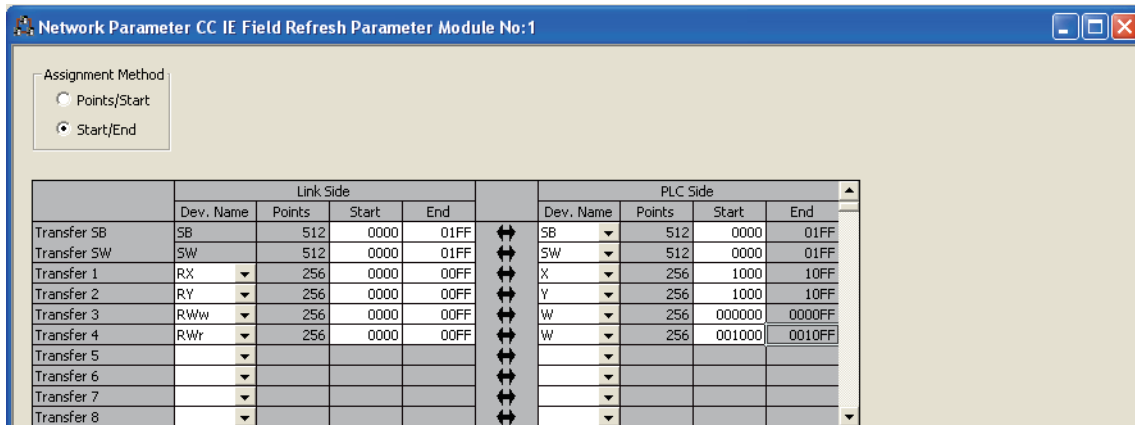

**5. Write the set parameter to the CPU module of the master station and reset the CPU module, or turn off and then on the programmable controller power supply.**

- ☞ [Online] ⇒ [Write to PLC]

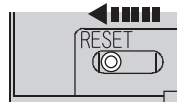

or Power OFF → ON

## (6) Setting on intelligent device station

### 1. Create a project on GX Works2.

Select "LCPU" for "PLC Series" and select "LJ72GF15-T2" for "PLC Type."

 [Project] ⇒ [New Project]

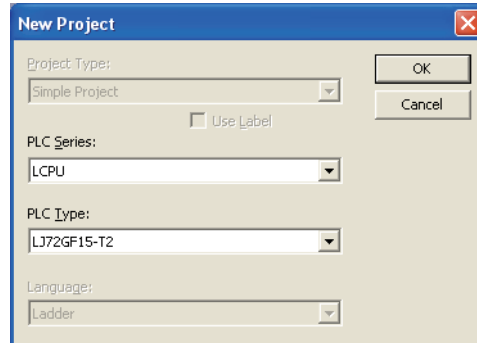

### 2. Display the PLC Parameter setting screen and configure the setting as follows.

 Project window ⇒ [Parameter] ⇒ [PLC Parameter] ⇒ "Communication Head Setting"

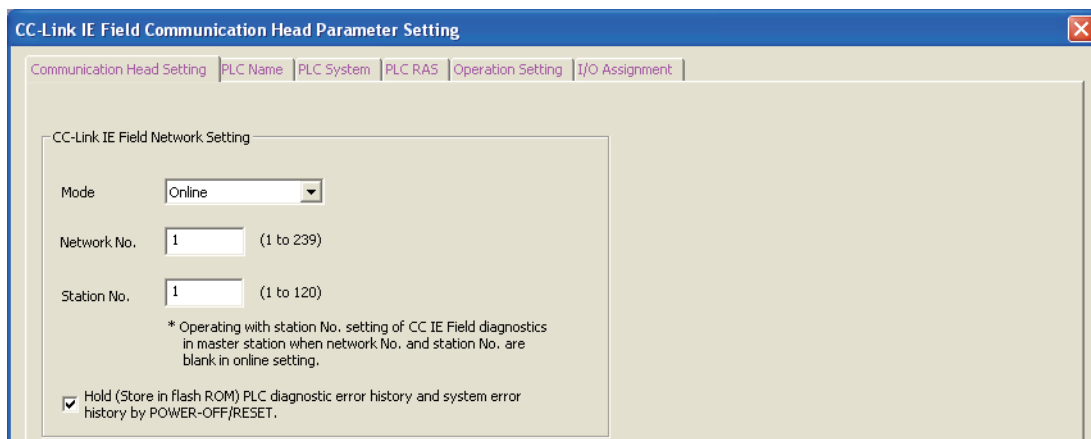



### 3. Add the D/A converter module (L60DA4) to the GX Works2 project.

Project window ⇒ [Intelligent Function Module] ⇒ Right-click ⇒ [New Module]

### 4. Display the Switch Setting screen for the D/A converter module (L60DA4) and configure the setting as follows.

Project window ⇒ [Intelligent Function Module] ⇒ [L60DA4] ⇒ [Switch Setting]

CH	Output range	HOLD/CLEAR function
CH1	4 to 20mA	CLEAR
CH2	4 to 20mA	CLEAR
CH3	4 to 20mA	CLEAR
CH4	4 to 20mA	CLEAR

**5. Display the initial setting screen for the D/A converter module (L60DA4) and configure the setting as follows.**

Project window ⇒ [Intelligent Function Module] ⇒ [L60DA4] ⇒ [Parameter]

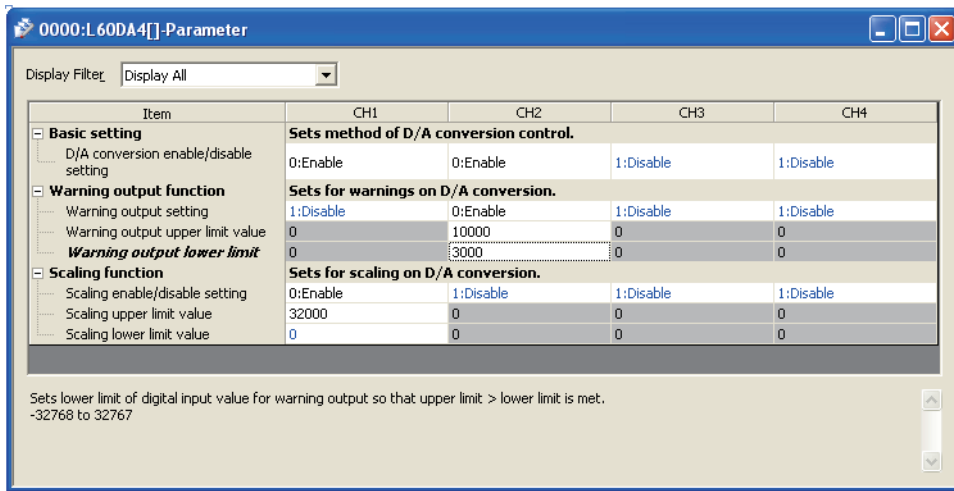

**6. Display the Auto Refresh setting screen for the D/A converter module (L60D/A4) and configure the setting as follows.**

Project window ⇒ [Intelligent Function Module] ⇒ [L60AD4]  
⇒ [Auto\_Refresh]

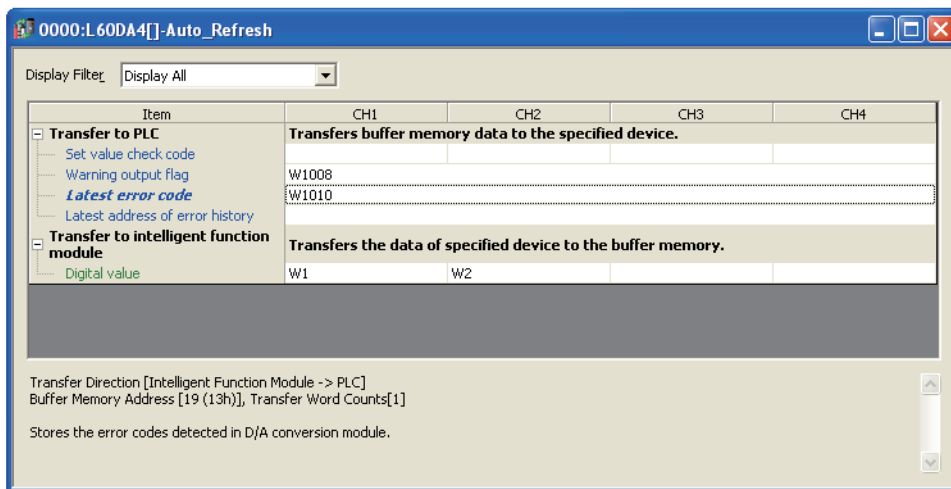

**7. Write the set parameter to the head module and reset the head module, or turn off and then on the programmable controller power supply.**

[Online] ⇒ [Write to PLC]

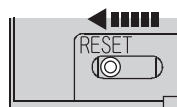

or Power OFF → ON

### (7) Program example

The following shows a program example. The program is written to the CPU module of the master station.

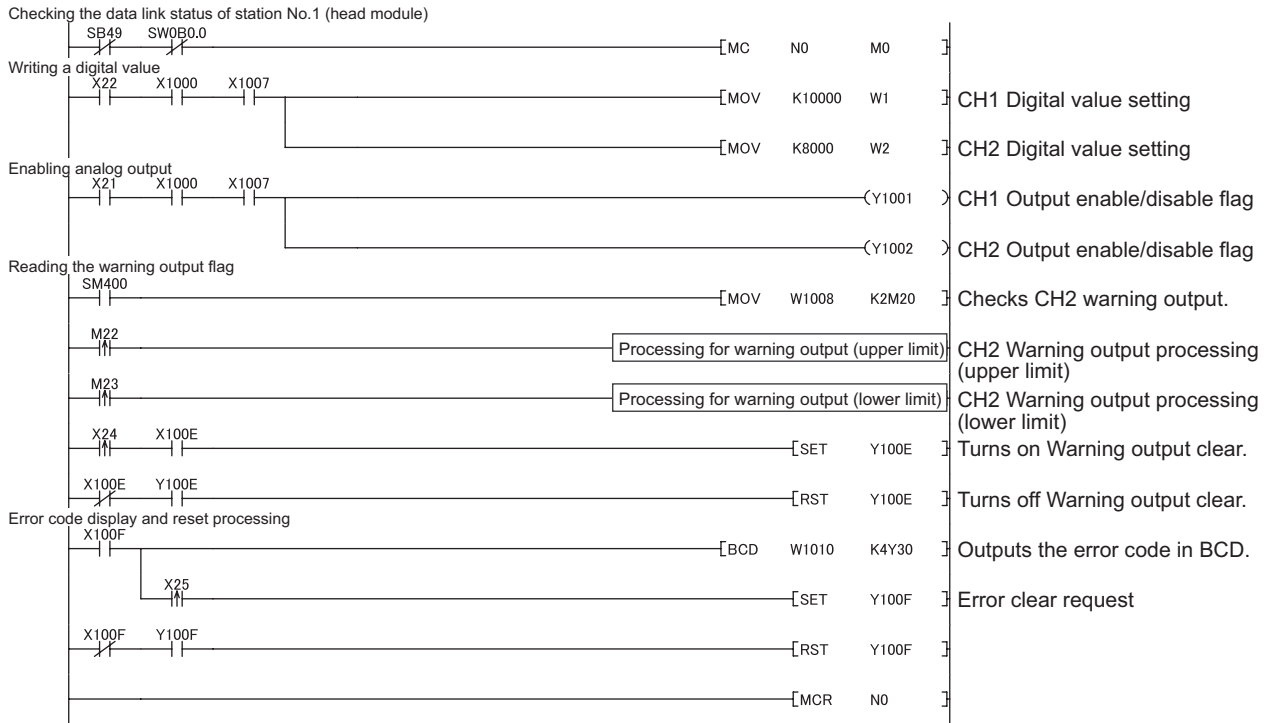

10.3 When D/A Converter Module is Connected to Head Module

# CHAPTER 11 TROUBLESHOOTING

---

This chapter describes errors that may occur while using the D/A converter module, and those troubleshooting.

## (1) Checking for the error codes and the alarm codes

Errors and alarms occurred in the D/A converter module can be checked with the following methods.

Check according to the purpose and application.

- Checking on the Module Detailed Information (☞ Page 91, Section 11.1)
- Checking by Latest error code (Un\G19) of the buffer memory address (☞ Page 92, Section 11.2)
- Checking on the module error collection function (☞ Page 92, Section 11.3)
- Checking by a display unit (☞ Page 75, Section 9.4)

# 11.1 Checking on the Module Detailed Information

The following describes how to check the errors on the module detailed information.

 [Diagnostics] ⇨ [System Monitor...]

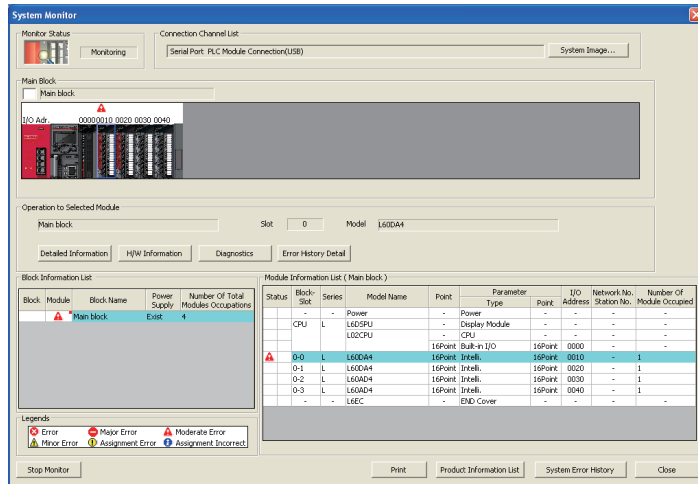

1. Select the D/A converter module in "Main Block" and click the **Detailed Information** button.

11

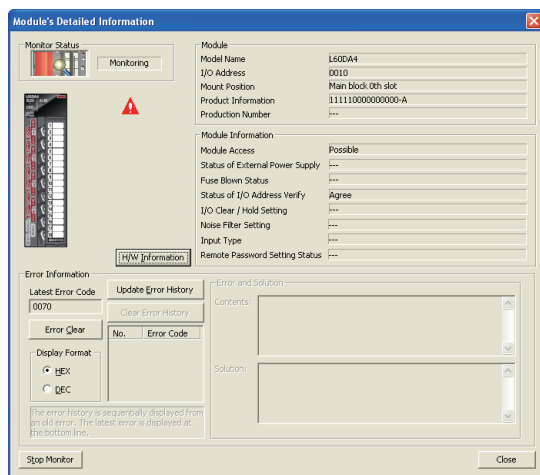

2. "Module Detailed Information" of the D/A converter module is displayed.

## 11.2 Checking by Latest Error Code (Un\G19)

The following describes how to check the error codes and alarm codes in Latest error code (Un\G19).

 [Online] ⇨ [Monitor] ⇨ [Device/Buffer Memory Batch]

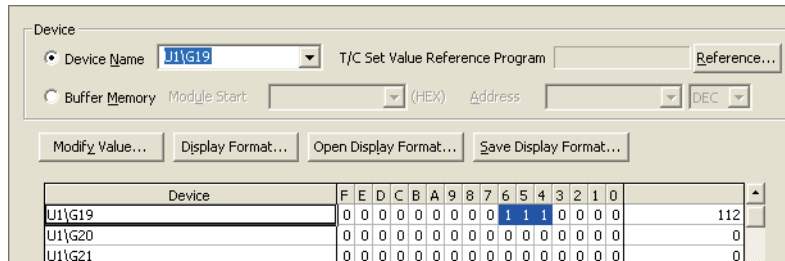

## 11.3 Checking on the Module Error Collection Function

Using the module error collection function stores the errors occurred in the D/A converter module to the CPU module. Once being stored, the errors remain even after powering-off or resetting of the CPU module or the head module.

### (1) How to check the errors by the module error collection function

To check the errors of the D/A converter module collected by the CPU module, open the "Error History" dialog box.

 [Diagnostics] ⇨ [System Monitor...] ⇨ click the **Error History Detail** button.

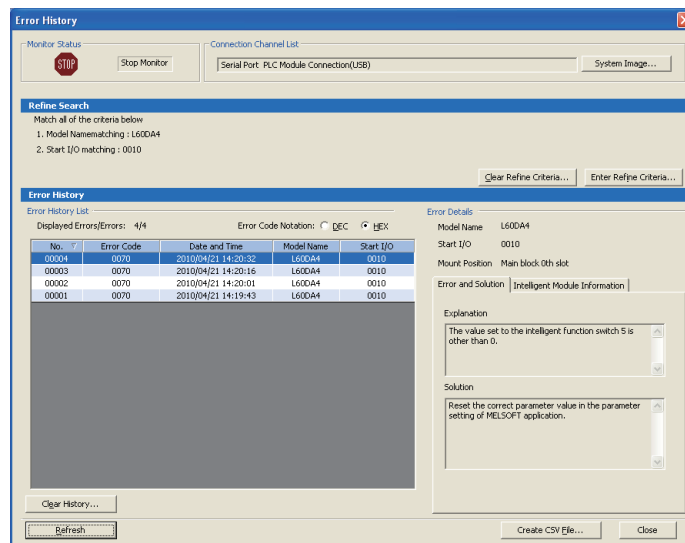



### Point

For checking method from module, refer to the following.

 MELSEC-L CC-Link IE Field Network Head Module User's Manual

### (2) Errors to be collected

The D/A converter module reports the following information to the CPU module:

- Error code list ( Page 93, Section 11.4)
- Alarm code list ( Page 94, Section 11.5)

# 11.4 Error Code List

When errors in the D/A converter module occur while writing data to or reading data from the CPU module, the following error codes are stored in Latest error code (Un\G19).

At the same time, the D/A converter module reports the errors to the CPU module.

Error code (decimal)	Description and cause of error	Action
10□	A value outside the range is set to Switch 1 (output range) in the Switch Setting for I/O and Intelligent Function Module screen of GX Works2. □ indicates the number of a channel where an invalid value is set.	Correct the value in the parameter setting of GX Works2.
111	A hardware failure occurs in the module.	Power off and then on the module. If the same error occurs again, the possible cause is a failure of the module. Please consult your local Mitsubishi service center or representative, explaining a detailed description of the problem.
112	Other than "0" is set to the intelligent function module switch 5.	Set "0" for Switch 5 in the Switch Setting for I/O and Intelligent Function Module screen of GX Works2.
113	The flash memory data is an error.	Check the analog output value. If the same error occurs again, please consult your local Mitsubishi service center or representative, explaining a detailed description of the problem.
120 <sup>*1*2</sup>	An invalid value is set to the offset/gain setting. The number of an error channel cannot be identified.	Perform offset/gain setting again for all channels where the user range setting has been configured. If the same error occurs again, the possible cause is a failure of the module. If the same error occurs again, the possible cause is a failure of the module. Please consult your local Mitsubishi service center or representative, explaining a detailed description of the problem.
12□ <sup>*1*3</sup>	An invalid value is set to the offset/gain setting. □ indicates the number of a channel where an error occurs.	Perform offset/gain setting again for the error channel. If the same error occurs again, the possible cause is a failure of the module. Please consult your local Mitsubishi service center or representative, explaining a detailed description of the problem.
161 <sup>*1*4</sup>	The G(P).OGSTOR instruction was executed in the offset/gain setting mode.	Do not execute the G(P).OGSTOR instruction in the offset/gain setting mode.
162 <sup>*1</sup>	<ul style="list-style-type: none"> <li>The G(P).OGSTOR instruction has been consecutively executed.</li> <li>In offset/gain setting, a setting value has been consecutively written to the flash memory more than 25 times.</li> </ul>	<ul style="list-style-type: none"> <li>Execute the G(P).OGSTOR instruction once per module.</li> <li>Do not write a setting value consecutively.</li> </ul>
163 <sup>*1</sup>	The G(P).OGSTOR instruction was executed for the module different from the one to which the G(P).OGLOAD instruction had been executed.	Execute the G(P).OGLOAD and G(P).OGSTOR instructions to the same module.
170 <sup>*1</sup>	The offset/gain setting is configured exceeding the maximum number of times.	The offset/gain setting will not be performed according to the setting.

Error code (decimal)	Description and cause of error	Action
40□*1	When the user range setting is performed or restored, the offset value is greater than or equal to the gain value. □ indicates the number of a channel where an error occurs.	Correct the value so that the offset value may be smaller than the gain value.
500*1	<ul style="list-style-type: none"> <li>When the offset/gain setting is performed, several channels have been set.</li> <li>In offset/gain setting, channel numbers or "0" is set for both Offset/gain setting mode Offset specification (Un\G22) and Offset/gain setting mode Gain specification (Un\G23).</li> </ul>	Correct the Offset/gain setting mode Offset specification (Un\G22) value and/or the Offset/gain setting mode Gain specification (Un\G23) value.
60□*1	A value set to CH□ Digital value (Un\G1 to Un\G4) is outside the range. □ indicates the number of a channel where an error occurs.	Set the value within the range.
62□*1	Among CH1 Warning output upper limit value (Un\G86) to CH4 Warning output lower limit value (Un\G93), any of the lower limit value is greater than or equal to the corresponding upper limit value. □ indicates the number of a channel where an error occurs.	Correct the value so that the upper limit value may be greater than the lower limit value.
700*1	In offset/gain setting mode, a value set to Offset/gain adjustment value specification (Un\G24) is outside the range.	Correct the value within the range of -3000 to 3000.
90□*1	A value outside -32000 to 32000 is set to any of CH1 Scaling lower limit value (Un\G54) to CH4 Scaling upper limit value (Un\G61). □ indicates the number of a channel where an error occurs.	Correct the value within the range of -32000 to 32000.
91□*1	Among CH1 Scaling lower limit value (Un\G54) to CH4 Scaling upper limit value (Un\G61), any of the lower limit value is greater than or equal to the corresponding upper limit value. □ indicates the number of a channel where an error occurs.	Correct the value so that the upper limit value may be greater than the lower limit value.

\*1 This error code can be cleared by turning off, on, and then off Error clear request (YF).

\*2 If an error occurs, D/A conversion performed in all channels will stop.  
Therefore, after performing the offset/gain setting again, reconfigure initial settings.

\*3 If an error occurs, D/A conversion performed in the error channel will stop.  
Therefore, after performing the offset/gain setting again, reconfigure initial settings.

\*4 An error code is not stored in Latest error code (Un\G19) but in the completion status of the G(P). OGSTOR instruction (Ⓢ +1).

## 11.5 Alarm Code List

The following shows the alarm code list.

Alarm code (decimal)	Description and cause of alarm	Action
15△□	A warning occurred. □ indicates the number of a channel where a warning occurred. △ indicates a value representing the following status: 0: Upper limit of a warning 1: Lower limit of a warning	Reset the digital value within the setting range and then turn off, on, and off Warning output clear request (YE).



# 11.6 Troubleshooting

## (1) When the RUN LED flashes or turns off

### (a) When flashing

Check item	Action
Is the operation mode setting in the offset/gain setting mode?	Switch the operation mode in the intelligent function module switch setting of GX Works2 to the normal mode. Or reconfigure the Switch 4 in the intelligent function module switch setting and set the normal mode.

### (b) When turning off

Check item	Action
Is the power supplied?	Check that the supply voltage of power supply module is within the rated range.
Is the capacity of power supply module enough?	Make sure that the power capacity is enough by calculating the current consumption of such as the connected CPU module, I/O modules, and intelligent function modules.
Is there any watchdog timer error?	Reset the CPU module, and check if the RUN LED turns on. If the RUN LED remains off, the module may be failed. Please consult your local Mitsubishi service center or representative, explaining a detailed description of the problem.
Is the module installed properly?	Check the module connection.

## (2) When the ERR. LED turns on or flashes

### (a) When turning on

Check item	Action
Does any error occur?	Check Latest error code (Un\G19), and take actions described in the error code list. (☞ Page 93, Section 11.4)

### (b) When flashing

Check item	Action
Is the value other than 0 set for Switch 5 of the intelligent function module switch setting?	With the parameter setting of GX Works2, set 0 for Switch 5 in the intelligent function module switch setting.

## (3) When the ALM LED flashes

Check item	Action
Is there any alarm output?	Check Warning output flag (Un\G48).

#### (4) When analog output value does not come out

Check item	Action
Is the external power supply 24VDC supplied?	Check External power supply READY flag (X7), and if the flag is turned OFF, provide a 24VDC power supply to the external power supply terminal (pin number 16, 17).
Is there any problem with wiring, such as off or disconnection of analog signal lines?	Check the faulty area by checking the signal line visually or conductively.
Is the CPU module in the STOP status?	Change the status of the CPU module to RUN.
Is the offset/gain setting correct?	Check whether the offset/gain is set properly. When using the user range setting, shift it to the factory default setting, and check the D/A conversion. If the D/A conversion is performed properly, reconfigure the offset/gain setting.
Is the output range setting correct?	Check Setting range (Un\G20) through the monitoring screen of GX Works2. When the output range setting is wrong, reconfigure the intelligent function module switch setting.
Is D/A conversion enable/disable setting (Un\G0) of the channel to output set to D/A conversion disabled?	Check D/A conversion enable/disable setting (Un\G0) through the monitoring screen of GX Works2. Then, set D/A conversion enable for Un\G0 with the sequence program or the parameter of the intelligent function module.
Is the D/A output enable/disable flag of the channel to output set to disabled?	Check whether CH□ Output enable/disable flag (Y1 to Y4) is OFF or ON through the monitoring screen of GX Works2. If CH□ Output enable/disable flag (Y1 to Y4) is OFF, review the sequence program.
Is any digital value written to the channel to output?	Check CH□ Digital value (Un\G1 to Un\G4) through the monitoring screen of GX Works2.
Is Operating condition setting request (Y9) being executed?	Check if the analog output is performed properly after turning Operating condition setting request (Y9) OFF → ON → OFF with GX Works2. If the output is performed properly, review the sequence program.

#### **Point**

If the analog output value does not come out even after taking the above actions, the module may be failed. Please consult your local Mitsubishi service center or representative, explaining a detailed description of the problem.

#### (5) When HOLD of analog output value is not available

Check item	Action
Is the HOLD/CLEAR function setting correct?	Set HOLD for the HOLD/CLEAR function in the intelligent function module switch setting of GX Works2. Also, check the setting value of switches in the intelligent function module switch setting.

# 11.7 Checking the Status of D/A Converter Module by the System Monitor

To check the LED status or the setting status of the intelligent function module switch setting, select "H/W Information" in the D/A converter module on the system monitor of GX Works2.

## (1) Hardware LED information

LED status is displayed.

No.	LED name	On status
1)	RUN LED	0000 <sub>H</sub> : Indicates the LED off.
2)	ERR. LED	0001 <sub>H</sub> : Indicates the LED on.
3)	ALM LED	Alternating indication between 0000 <sub>H</sub> and 0001 <sub>H</sub> : Indicates the LED flashing. (GX Works2 displays the communication status with the D/A converter module, so that the displaying intervals of 0000 <sub>H</sub> and 0001 <sub>H</sub> are not always even.)

## (2) Hardware switch information

The setting status of the intelligent function module switch setting is displayed.

For details on the setting status, refer to the following.

- Intelligent function module switch setting (  Page 126, Appendix 8.1(2))

Item	Intelligent function module switch
RANGE	Switch 1
—	Switch 2
HOLD/CLEAR	Switch 3
MODE	Switch 4
—	Switch 5

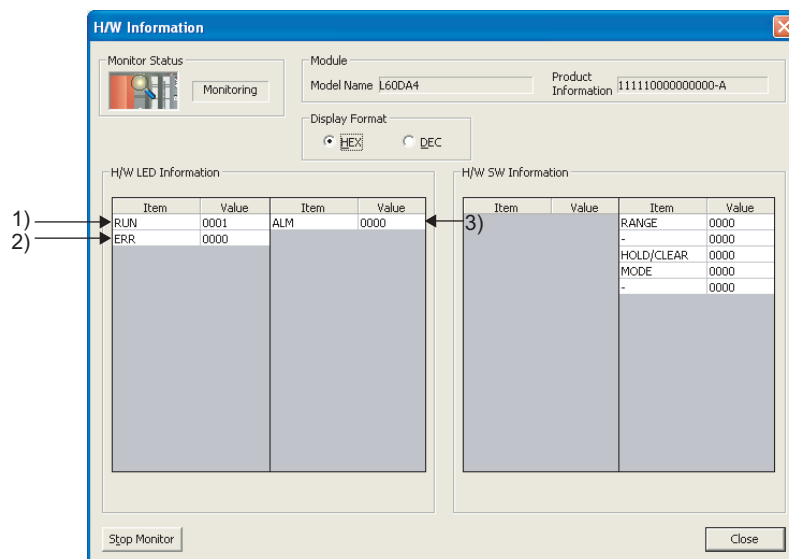

# APPENDICES

## Appendix 1 Details of I/O Signals

This section describes the details of I/O signals of D/A converter module for the CPU module.

The I/O number described in Appendix 1 shows the case that the start I/O number of the D/A converter module is set to "0".

### Appendix 1.1 Input Signal

#### (1) Module READY (X0)

Module READY (X0) turns ON to indicate that the preparation for the D/A conversion is completed after the power-on or after the reset operation of the CPU module.

In the following cases, Module READY (X0) turns off.

- In the offset/gain setting mode (In this case, the D/A conversion processing is executed).
- When a watch dog timer error occurs to the D/A converter module (In this case, the D/A conversion processing is not executed).

#### (2) External power supply READY flag (X7)

100ms after the external power supply is supplied, External power supply READY flag (X7) turns on, and the D/A conversion processing is executed.

The following shows the time chart when the external power supply is turned to ON after the power-on of the CPU module.

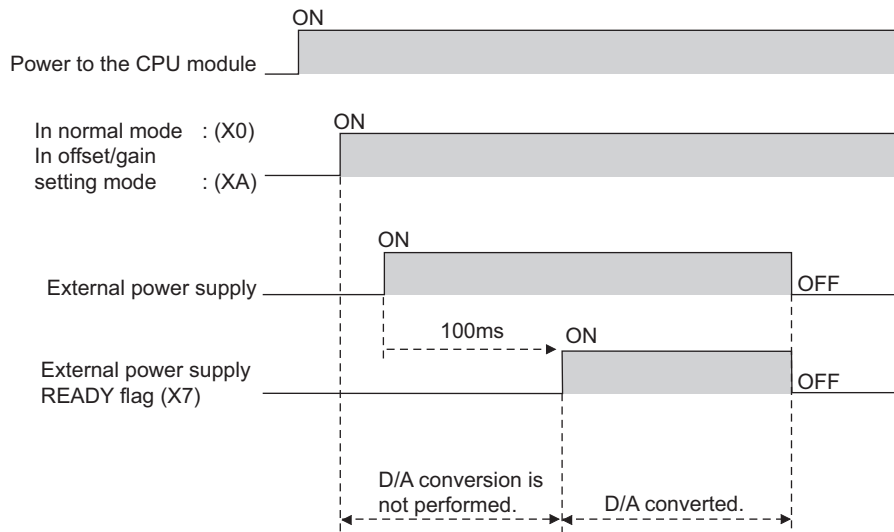

##### (a) Normal mode

When the module is started with the external power supply input status, External power supply READY flag (X7) turns from OFF to ON, at the same time as Module READY (X0) turns from OFF to ON.

Also, if Module READY (X0) is ON and the external power supply is input later, External power supply READY flag (X7) turns from OFF to ON after 100ms.

**(b) Offset/gain setting mode**

When the module is started with the external power supply input status, External power supply READY flag (X7) turns from OFF to ON at the same time as Offset/gain setting mode flag (XA) turns from OFF to ON. Also, if Offset/gain setting mode flag (XA) is ON and the external power supply is input later, External power supply READY flag (X7) turns from OFF to ON after 100ms.

**(c) When the external power supply is not supplied, or when the time after the supply is less than 100ms.**

The following occurs.

- External power supply READY flag (X7) turns OFF, and the D/A conversion processing is not executed.
- The analog output value becomes 0V/0mA.
- Out-of-range digital value error detection and alarm output are not executed.

**Point**

- For the external power supply, supply the voltage and current indicated in the performance specifications.
- When executing D/A conversion, make sure that Module READY (X0) and External power supply READY flag (X7) are ON.

**(3) Operating condition setting completed flag (X9)**

When changing the following settings, use Operating condition setting completed flag (X9) as an interlock condition to turn Operating condition setting request (Y9) OFF → ON → OFF.

- D/A conversion enable/disable setting (Un\G0)
- Warning output setting (Un\G47)
- CH□ Warning output upper limit value (Un\G86, Un\G88, Un\G90, Un\G92)
- CH□ Warning output lower limit value (Un\G87, Un\G89, Un\G91, Un\G93)
- Scaling enable/disable setting (Un\G53)
- CH□ Scaling lower limit value (Un\G54, Un\G56, Un\G58, Un\G60)
- CH□ Scaling upper limit value (Un\G55, Un\G57, Un\G59, Un\G61)

In the case of the following status, Operating condition setting completed flag (X9) turns OFF.

- When Operating condition setting request (Y9) is ON

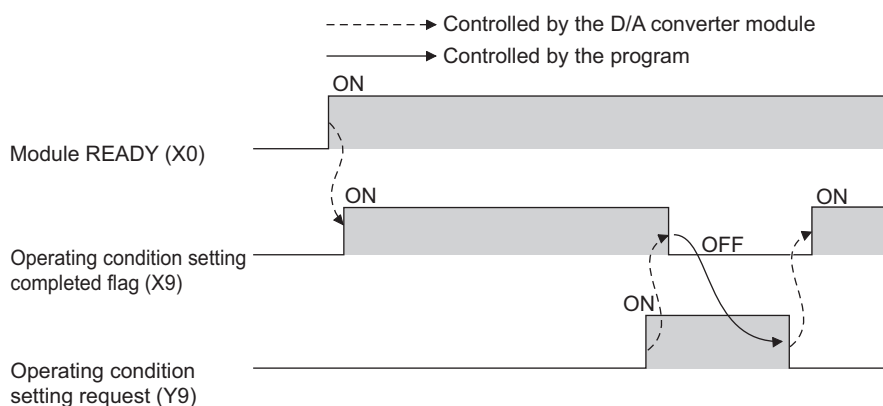

#### (4) Offset/gain setting mode flag (XA)

##### (a) Offset/gain setting mode

When registering the offset or gain value, which was adjusted with the offset/gain setting, Offset/gain setting mode flag (XA) is used as an interlock condition to turn User range writing request (YA) OFF → ON → OFF. For the offset/gain setting, refer to the following.

- Offset/gain setting (👉 Page 125, Appendix 8.1)

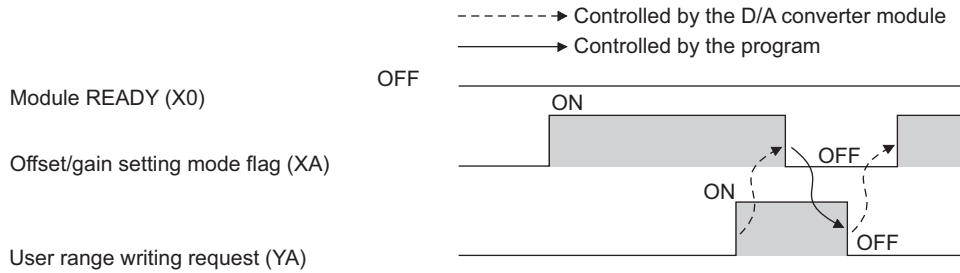

##### (b) Normal mode

In the user range restoration, use Offset/gain setting mode flag (XA) as an interlock condition to turn User range writing request (YA) OFF → ON → OFF.

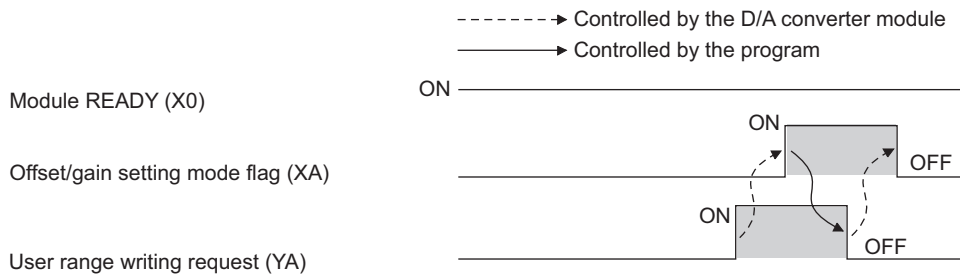

#### (5) Channel change completed flag (XB)

When changing a channel to perform the offset/gain setting, use Channel change completed flag (XB) as an interlock condition to turn Channel change request (YB) OFF → ON → OFF.

For the offset/gain setting, refer to the following.

- Offset/gain setting (👉 Page 125, Appendix 8.1)

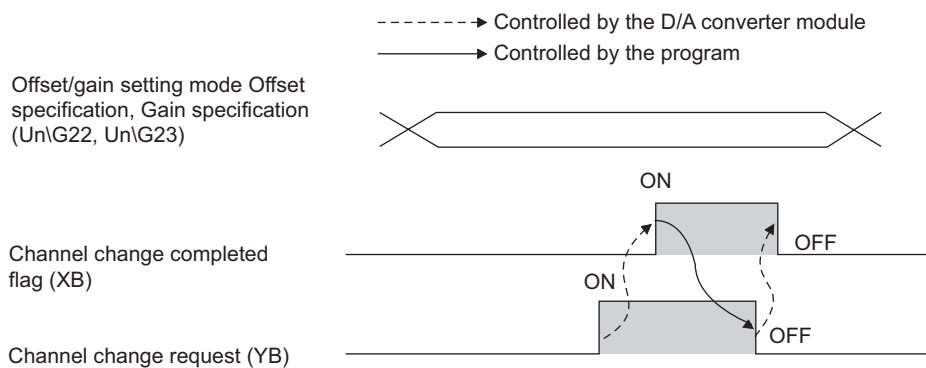

### (6) Set value change completed flag (XC)

When adjusting the offset/gain setting, Set value change completed flag (XC) is used as an interlock condition to turn Set value change request (YC) OFF → ON → OFF.

For the offset/gain setting, refer to the following.

- Offset/gain setting (☞ Page 125, Appendix 8.1)

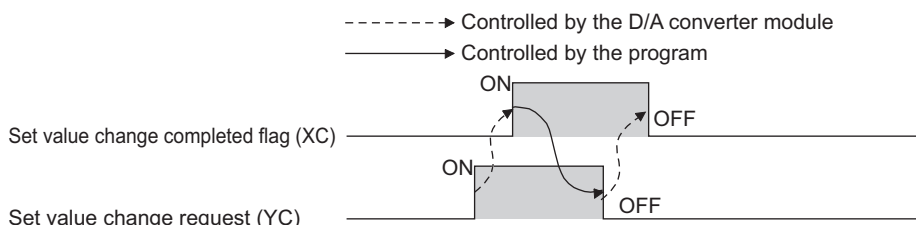

### (7) Warning output signal (XE)

In D/A conversion enabled channels, if any digital value exceeds the alarm output upper limit value or is below than the alarm output lower limit value, Warning output signal (XE) turns ON.

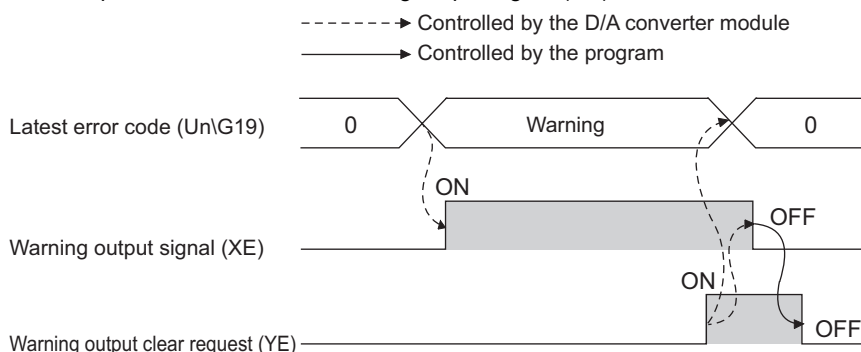

#### (a) Turning OFF Warning output signal (XE)

Turn OFF by the following two methods.

- Turning OFF → ON → OFF Warning output clear request (YE)
- Turning OFF → ON → OFF Operating condition setting request (Y9)

When alarm code is stored in Latest error code (Un\G19), Warning output signal (XE) is cleared to 0.

### (8) Error flag (XF)

Error flag (XF) turns ON if an error occurs.

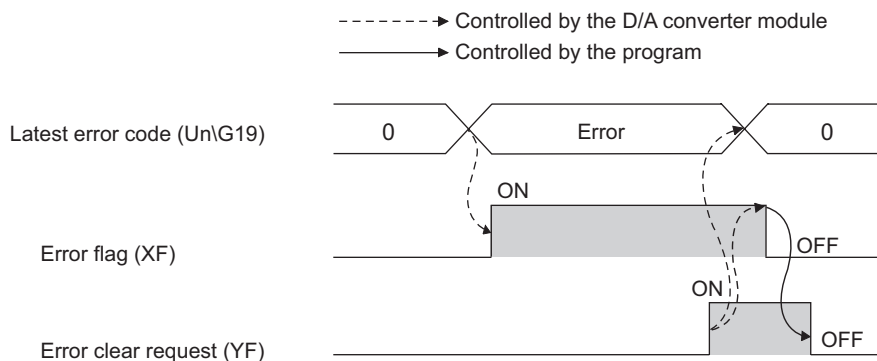

#### (a) Turning OFF Error flag (XF)

Eliminate the error cause, and turn OFF → ON → OFF Error clear request (YF).

(At the timing of turning Error clear request (YF) from OFF to ON, Error flag (XF) and Latest error code (Un\G19) are cleared.)

## Appendix 1.2 Output Signal

---

### (1) CH□ Output enable/disable flag (Y1 to Y4)

This function sets whether to output the D/A-converted value or the offset value, for each channel.

ON : D/A conversion value

OFF : offset value

#### (a) D/A conversion speed

The D/A conversion speed is calculated by  $20\mu\text{s}$  x number of conversion enabled channels, regardless of the turning of CH□ Output enable/disable flag (Y1 to Y4) from OFF to ON.

### (2) Operating condition setting request (Y9)

To validate the following settings, turn Operating condition setting request (Y9) OFF → ON → OFF.

- D/A conversion enable/disable setting (Un\G0)
- Warning output setting (Un\G47)
- CH□ Warning output upper limit value (Un\G86, Un\G88, Un\G90, Un\G92)
- CH□ Warning output lower limit value (Un\G87, Un\G89, Un\G91, Un\G93)
- Scaling enable/disable setting (Un\G53)
- CH□ Scaling lower limit value (Un\G54, Un\G56, Un\G58, Un\G60)
- CH□ Scaling upper limit value (Un\G55, Un\G57, Un\G59, Un\G61)

For the timing of turning the signal OFF → ON → OFF, refer to the following.

- Operating condition setting completed flag (X9) (☞ Page 98, Appendix 1.1)

### (3) User range writing request (YA)

#### (a) Offset/gain setting mode

Turn User range writing request (YA) OFF → ON → OFF to register the adjusted offset/gain setting values in the D/A converter module.

For the timing of turning the signal OFF → ON → OFF, refer to the following.

- Offset/gain setting mode flag (XA) (☞ Page 98, Appendix 1.1)

#### (b) Normal mode

Turn User range writing request (YA) OFF → ON → OFF to perform the user range restoration.

For the timing of turning the signal OFF → ON → OFF, refer to the following.

- Offset/gain setting mode flag (XA) (☞ Page 98, Appendix 1.1)

For user range restoration, refer to the following.

- Saving and restoring offset/gain values (☞ Page 65, Section 8.10)

### (4) Channel change request (YB)

Turn Channel change request (YB) OFF → ON → OFF to change a channel to perform the offset/gain setting.

For the timing of turning the signal OFF → ON → OFF, refer to the following.

- Channel change completed flag (XB) (☞ Page 98, Appendix 1.1)

### (5) Set value change request (YC)

- Turn Set value change request (YC) OFF → ON → OFF to change the analog output value during the adjustment of offset/gain setting.

The analog output is changed according to the value set in Offset/gain adjustment value specification (Un\G24).



**(6) Warning output clear request (YE)**

Turn Warning output clear request (YE) OFF → ON → OFF to clear the alarm output.

For the timing of turning the signal OFF → ON → OFF, refer to the following.

- Warning output signal (XE) (☞ Page 98, Appendix 1.1)

**(7) Error clear request (YF)**

Turn Error clear request (YF) OFF → ON → OFF to clear errors.

For the timing of turning the signal OFF → ON → OFF, refer to the following.

- Error flag (XF) (☞ Page 98, Appendix 1.1)

# Appendix 2 Details of Buffer Memory Addresses

The following describes the details of buffer memory.

## (1) D/A conversion enable/disable setting (Un\G0)

Sets whether to enable or disable D/A conversion for each channel.

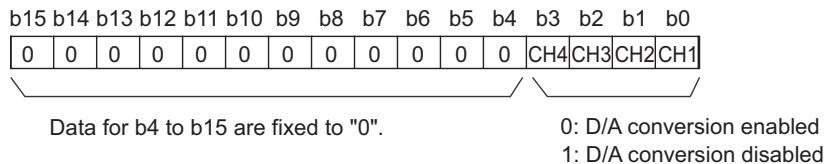

### (a) Enabling the setting

Turn OFF → ON → OFF Operating condition setting request (Y9) to enable the setting.

### (b) Default value

All channels are set to D/A conversion disable (1) as the default value.

## (2) CH□ Digital value (Un\G1 to Un\G4)

This is the area where the digital value in signed 16-bit binary for performing the D/A conversion is written from the CPU module.

When the value out of the setting range is written, the D/A conversion is performed with the upper and lower limit value of the settable range. In addition, a check code is stored in CH□ Set value check code (Un\G11 to Un\G14) and an error code is stored in Latest error code (Un\G19).

Output range setting	If the scaling function is disabled		If the scaling function is enabled *1
	Settable range (practical range)	A written digital value out of the settable range is treated as	Settable range
0: 4 to 20mA	0 to 20479 (practical range: 0 to 20000)	20480 or more: 20479 -1 or less: 0	-32000 to 32000
1: 0 to 20 mA			
2: 1 to 5V			
3: 0 to 5V			
4: -10 to 10V	-20480 to 20479	20480 or more: 20479	
F: User range setting	(practical range: -20000 to 20000)	-20481 or less: -20480	

\*1 When the scaling function is enabled, the settable range and practical range depend on the settings for scaling upper and lower limit values.

### (3) CH□ Set value check code (Un\G11 to Un\G14)

Check code is stored in this area if the digital value out of the settable range is written to CH□ Digital value (Un\G1 to Un\G4).

The following shows the check codes to be stored when the digital value out of the setting range is written.

Check code	Description
000F <sub>H</sub>	A digital value exceeding the settable range is written.
00F0 <sub>H</sub>	A digital value falling short of the settable range is written.
00FF <sub>H</sub>	A digital value falling short of the setting range and digital value exceeding the setting range are written. The check code of 00FF <sub>H</sub> is stored in the following case, for example. <ul style="list-style-type: none"> <li>• Write the digital value exceeding the settable range, first.</li> <li>• Then, write the digital value falling short of the settable range before resetting the check code.</li> </ul>

Once the check code is stored, the code remains even the digital value is within the settable range.

While the scaling function is enabled, the check is performed to the scale-converted value of CH□ Digital value (Un\G1 to Un\G4).

Note that some errors may be observed in the digital value to which a check code is stored due to the calculation error of scale conversion when a scale-converted value is out of the settable range.

#### (a) Resetting the setting value check codes

Rewrite the digital value to the value within the settable range and turn Error clear request (YF) OFF → ON → OFF.

### (4) Latest error code (Un\G19)

Error codes or alarm codes detected in the D/A converter module are stored.

For details on error codes or alarm codes, refer to the following.

- Error code list (☞ Page 93, Section 11.4)
- Alarm code list (☞ Page 94, Section 11.5)

### (5) Setting range (Un\G20)

b15 to b12	b11 to b8	b7 to b4	b3 to b0
CH4	CH3	CH2	CH1

Output range	Setting value
4 to 20mA	0 <sub>H</sub>
0 to 20mA	1 <sub>H</sub>
1 to 5V	2 <sub>H</sub>
0 to 5V	3 <sub>H</sub>
-10 to 10V	4 <sub>H</sub>
User range setting	F <sub>H</sub>

#### Point

Output range cannot be changed in setting range (Un\G20).  
For changing the setting, refer to the following.

- Switch Setting (☞ Page 39, Section 7.2)

## (6) Offset/gain setting mode Offset specification (Un\G22), Offset/gain setting mode Gain specification (Un\G23)

Specify the channel to perform the offset/gain setting adjustment.

For details on offset/gain setting, refer to the following.

- Offset/Gain Setting (👉 Page 42, Section 7.5)

	b15	b14	b13	b12	b11	b10	b9	b8	b7	b6	b5	b4	b3	b2	b1	b0
Offset/gain setting mode Offset specification (Un\G22)	0	0	0	0	0	0	0	0	0	0	0	0	CH4	CH3	CH2	CH1
Offset/gain setting mode Gain specification (Un\G23)	0	0	0	0	0	0	0	0	0	0	0	0	CH4	CH3	CH2	CH1

Data for b4 to b15 are fixed to "0".

1: Setting-target channel  
0: Invalid

### (a) Enabling the setting

Turn OFF → ON → OFF Channel change request (YB) to enable the setting.

#### **Point** 🔍

Only one channel can be specified at a time. When multiple channels are set at a time, the offset/gain setting mode error occurs and the error code is stored in Latest error code (Un\G19).

## (7) Offset/gain adjustment value specification (Un\G24)

This is the area to set the adjustment value of analog output value in the offset/gain setting mode.

**Ex.** The setting value of 1000 corresponds to:

the analog adjustment value of approx. 0.33V (in voltage output) or approx. 0.69mA (in current output).

### (a) Setting range

The setting range is as follows;

- Setting range: -3000 to 3000

### (b) Enabling the setting

Turn OFF → ON → OFF Set value change request (YC) to enable the setting.

**(8) HOLD/CLEAR function setting (Un\G26)**

The HOLD/CLEAR function setting status of the D/A converter module can be checked.

b15 to b12	b11 to b8	b7 to b4	b3 to b0
CH4	CH3	CH2	CH1

HOLD/CLEAR function setting	Setting value
CLEAR	0 <sub>H</sub>
HOLD	1 to F <sub>H</sub> (value other than 0)

**Point**

The setting cannot be changed with HOLD/CLEAR function setting (Un\G26).  
For changing the setting, refer to the following.

- Switch Setting (☞ Page 39, Section 7.2)

**(9) Warning output setting (Un\G47)**

Sets whether to enable or disable the alarm output for each channel.

b15	b14	b13	b12	b11	b10	b9	b8	b7	b6	b5	b4	b3	b2	b1	b0
0	0	0	0	0	0	0	0	0	0	0	0	CH4	CH3	CH2	CH1

Data for b4 to b15 are fixed to "0".

0: Enabled  
1: Disabled

**(a) Enabling the setting**

Turn OFF → ON → OFF Operating condition setting request (Y9) to enable the setting.

**(b) Default value**

All channels are set to disable (1) as the default value.

## (10) Warning output flag (Un\G48)

Alarms can be checked if the alarm is the upper limit warning or lower limit warning, for each channel.

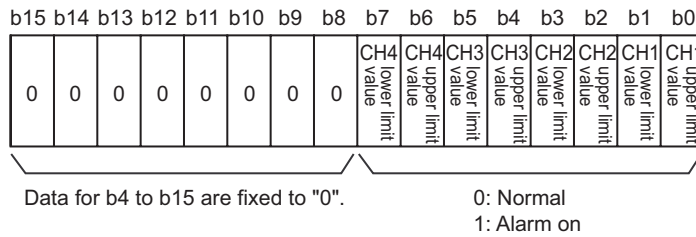

### (a) Warning output flag (Un\G48) status

- When a digital value is out of the range set in CH1 Warning output upper limit value (Un\G86) to CH4 Warning output lower limit value (Un\G93), Warning output flag corresponding to each channel turns to alarm output (1).
- When an error is detected in any D/A conversion enable or Warning output enable channels, Warning output signal (XE) is also turned to ON.

### (b) Clearing the Warning output flag

There are two methods for clearing Warning output flag (Un\G48).

- Turning OFF → ON → OFF Operating condition setting request (Y9)
- Turning OFF → ON → OFF Warning output clear request (YE)

## (11) Scaling enable/disable setting (Un\G53)

Sets whether to enable or disable the scaling for each channel.

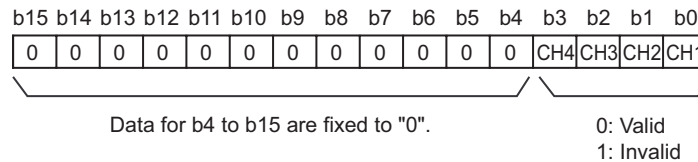

### (a) Enabling the setting

Turn OFF → ON → OFF Operating condition setting request (Y9) to enable the setting.

### (b) Default value

All channels are set to disable (1) as the default value.

**(12)CH□ Scaling lower limit value (Un\G54, Un\G56, Un\G58, Un\G60),  
CH□ Scaling upper limit value (Un\G55, Un\G57, Un\G59, Un\G61)**

Set the input range of digital value when using the scaling function.

**(a) Setting range**

The setting range is as follows;

- Setting range: -32000 to 32000 (scaling upper limit value > scaling lower limit value)

**(b) Enabling the setting**

Turn OFF → ON → OFF Operating condition setting request (Y9) to enable the setting.

**(c) Default value**

All channels are set to 0.

**Point!**

- When a value out of the setting range is set, an error occurs and an error code is stored in Latest error code (Un\G19).
- This setting is not reflected in the D/A converter module if Scaling enable/disable setting (Un\G53) is set to disable.

**(13)CH□ Warning output upper limit value (Un\G86, Un\G88, Un\G90, Un\G92),  
CH□ Warning output lower limit value (Un\G87, Un\G89, Un\G91, Un\G93)**

Set the upper and lower limit values of the digital value to output an alarm.

When the settings meet "alarm output upper limit value  $\geq$  alarm output lower limit value", an error code is stored in Latest error code (Un\G19).

**(a) Setting range**

The setting range is as follows;

- Setting range: -32768 to 32767 (alarm output upper limit value > alarm output lower limit value)

**(b) Enabling the setting**

Turn OFF → ON → OFF Operating condition setting request (Y9) to enable the setting.

**(c) Default value**

All channels are set to 0.

**Point!**

- If Scaling enable/disable setting (Un\G53) is set to "enable", make sure to specify values that reflect scale conversion.
- In channels whose Warning output setting (Un\G47) are set to "disable", the values set for the disabled channels of CH□ Warning output upper limit value (Un\G86, Un\G88, Un\G90, Un\G92) and CH□ Warning output lower limit value (Un\G87, Un\G89, Un\G91, Un\G93) are ignored.

### (14) Mode switching setting (Un\G158, Un\G159)

Set the setting value for the mode to be switched to.

Mode switching to	Setting value	
	Un\G158	Un\G159
Normal mode	0964 <sub>H</sub>	4144 <sub>H</sub>
Offset/gain setting mode	4144 <sub>H</sub>	0964 <sub>H</sub>

#### (a) Setting procedure

Turn OFF → ON → OFF Operating condition setting request (Y9) to enable the setting.

#### (b) After the mode switching

When the mode is switched, this area is cleared to zero and Operating condition setting completed flag (X9) is turned to OFF.

After checking that Operating condition setting completed flag (X9) is OFF, turn Operating condition setting request (Y9) to OFF.

#### *Point*

When a value out of the setting range is written, the mode is not switched and only the operating condition is changed.

### (15) Pass data classification setting (Un\G200)

This is the area for saving and restoring the offset/gain setting value in user range setting.

Specify the offset/gain setting value to be saved and restored as either voltage or current.

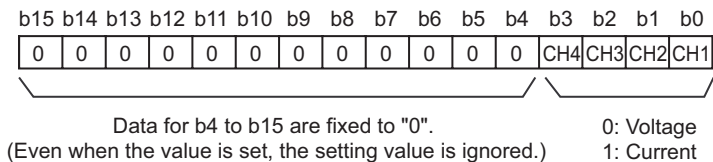



## (16)CH1 Industrial shipment settings offset value (Un\G202) to CH4 User range settings gain value (Un\G217)

This is the area for restoring the offset/gain setting value in user range setting.

The data to be used when restoring the offset/gain setting value in user range setting is stored.

The data is stored when;

- Writing the initial settings by a programming tool
- Turning OFF → ON Operating condition setting request (Y9) \*1
- Turning OFF → ON User range writing request (YA) (in offset/gain setting mode)

\*1 The data is not saved when the setting value is written to Mode switching setting (Un\G158, Un\G159).

When restoring the offset/gain setting value in user range setting, set the data saved in this area to the same area in the D/A converter module where the data is restored.

### (a) Procedure for saving offset/gain values in the buffer memory and recording the saved values

1. Configure Pass data classification setting (Un\G200)
2. Turn OFF → ON Operating condition setting request (Y9)
3. Compare the values in CH1 Industrial shipment settings offset value (Un\G202) to CH4 User range settings gain value (Un\G217) with the values in the range reference tables.
4. When the value is appropriate, record the values in Pass data classification setting (Un\G200) and CH1 Industrial shipment settings offset value (Un\G202) to CH4 User range settings gain value (Un\G217).

For details on the offset/gain value setting, refer to the following.

- Offset/gain Setting (☞ Page 42, Section 7.5)

## (17)Latest error code address (Un\G1800)

The latest address of error log is stored.

## (18)Error history No. □ (Un\G1810 to Un\G1969)

Up to 16 errors occurred in the module are recorded.

	b15	to	b8	b7	to	b0
Un\G1810	Error code					
Un\G1811	First two digits of the year			Last two digits of the year		
Un\G1812	Month			Day		
Un\G1813	Hour			Minute		
Un\G1814	Second			Day of the week		
Un\G1815	System area					
to						
Un\G1819						

# Appendix 3 I/O Conversion Characteristic of D/A Conversion

I/O conversion characteristic of D/A conversion means the slope of the line connected between the offset value and gain value when converting the digital value written from the CPU module to analog output value (voltage or current output).

### (1) Offset value

This is the analog output value (voltage or current) when the digital value set from the CPU module is 0.

### (2) Gain value

This is the analog output value (voltage or current) when the digital value set from the CPU module is 20000.

### (3) Voltage output characteristic

The following graph shows the voltage output characteristic.

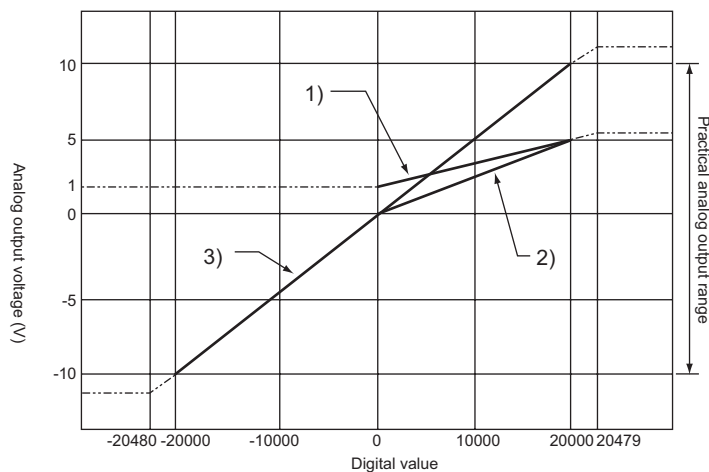

No.	Output range setting	Offset value	Gain value	Digital value	Resolution
1)	1 to 5V	1V	5V	0 to 20000	200 $\mu$ V
2)	0 to 5V	0V	5V		250 $\mu$ V
3)	-10 to 10V	0V	10V	-20000 to 20000	500 $\mu$ V
—	User range setting	*1	*1		333 $\mu$ V <sup>*2</sup>

\*1 Set the offset value and gain value in user range setting within the range satisfying the following two conditions.

- Setting range: -10 to 10V
- ((Gain value) - (offset value))  $\geq$  6.6V

\*2 This is the maximum resolution in user range setting.

### Point

Use the value within the practical digital input range and practical analog output range of each output range. If a value out of the range is used, the accuracy may not fall within the range of performance specifications. (Do not use the value in the dotted line in the graph above.)

#### (4) Current output characteristic

The following graph shows the current output characteristic.

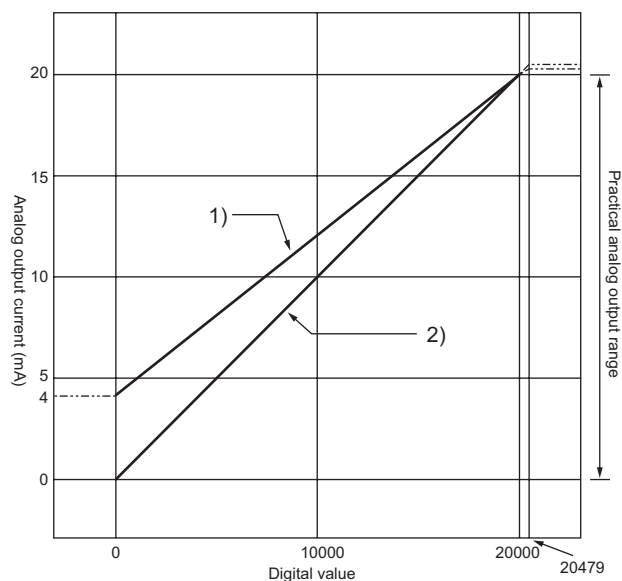

No.	Output range setting	Offset value	Gain value	Digital value	Resolution
1)	4 to 20mA	4mA	20mA	0 to 20000	800nA
2)	0 to 20mA	0mA	20mA		1000nA
—	User range setting	*1	*1	-20000 to 20000	700nA*2

\*1 Set the offset value and gain value in user range setting within the range satisfying the following two conditions.

- Setting range: 0 to 20mA
- $((\text{Gain value}) - (\text{offset value})) \geq 13.8\text{mA}$

\*2 This is the maximum resolution in user range setting.

**Point!**

Use the value within the practical digital input range and practical analog output range of each output range. If a value out of the range is used, the accuracy may not fall within the range of performance specifications. (Do not use the value in the dotted line in the graph above.)

# Appendix 4 D/A Conversion Accuracy

---

This is the accuracy for the maximum value of analog output value.

Even when changing the offset/gain setting and output range to change the output characteristics, the accuracy does not change and is kept within the range of described performance specifications.

The following graph shows the fluctuation range of accuracy when the range of -10 to 10V is selected.

The analog output accuracy is within  $\pm 0.1\%$  ( $\pm 10\text{mV}$ ) when the ambient temperature is  $25\pm 5^\circ\text{C}$  and within  $\pm 0.3\%$  ( $\pm 30\text{mV}$ ) when the ambient temperature is 0 to  $55^\circ\text{C}$ . (Excluding the case under noise effect.)

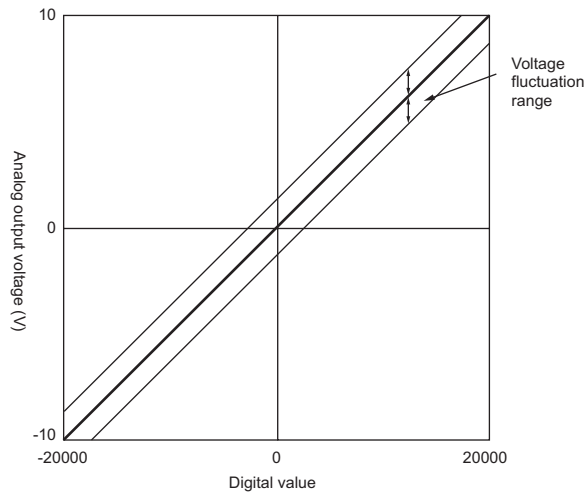

## Appendix 5 Dedicated Instruction

---

This chapter describes the dedicated instructions that can be used in D/A converter module.

### Appendix 5.1 Instruction List

---

The following shows the dedicated instructions that can be used in D/A converter module.

Instruction	Description
G(P).OFFGAN	The operation mode is changed from the normal mode to the offset/gain setting mode. The operation mode is changed from the offset/gain setting mode to the normal mode.
G(P).OGLOAD	The offset/gain set value in the user range setting is read out to the CPU module.
G(P).OGSTOR	The offset/gain set value in the user range setting stored in the CPU module is restored to the D/A converter module.

## Appendix 5.2 G(P).OFFGAN

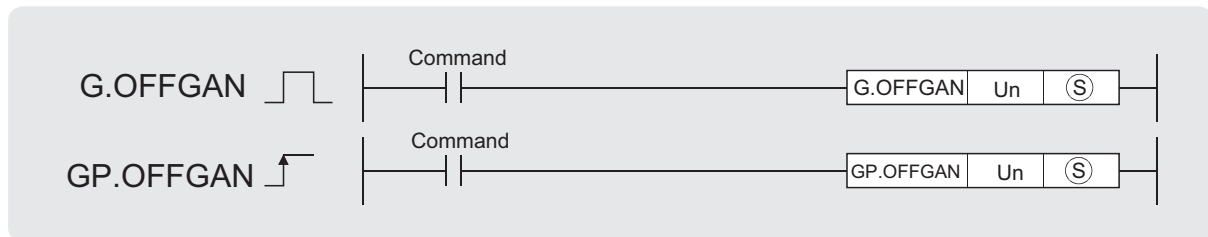

Setting data	Internal device		R, ZR	J□□		U□\G□	Zn	Constant	Others
	Bit	Word		Bit	Word				
Ⓢ	—	○				—			

### (1) Setting data

Device	Description	Setting range	Data type
Un	Start I/O number of module	0 to FE <sub>H</sub>	BIN 16-bit
Ⓢ	Switching the operation mode 0: switch to the normal mode 1: switch to the offset/gain setting mode When a value other than above is set, the mode switches to the offset/gain setting mode.	0, 1	BIN 16-bit

### (2) Functions

This instruction switches the operation mode of the D/A converter module.

- Normal mode → offset/gain setting mode (Offset/gain setting mode flag (XA) is ON)
- Offset/gain setting mode → normal mode (Offset/gain setting mode flag (XA) is OFF)

#### Point

- When the mode is switched from the offset/gain setting mode to the normal mode, Module READY (X0) turns from OFF to ON.  
Note that if a program includes the initial settings to be executed at ON of Module READY (X0), this instruction performs the initial setting process.
- When the mode switching (normal mode → offset/gain setting mode, or offset/gain setting mode → normal mode) is performed, the D/A conversion stops.
- When the mode is switched from the offset/gain setting mode to the normal mode, all-channel D/A conversion disable (000F<sub>H</sub>) is stored in D/A conversion enable/disable setting (Un\G0).  
To resume the D/A conversion, set D/A conversion enable (0) for the corresponding channels and turn Operating condition setting request (Y9) OFF → ON → OFF.

### (3) Errors

The instruction has no errors.

### (4) Program example

The following shows the program of the D/A converter module, installed in I/O number X/Y10 to X/Y1F, with the following conditions:

- turning ON M10 switches the operation mode to the offset/gain setting mode, and
- turning OFF M10 restores the operation mode to the normal mode.

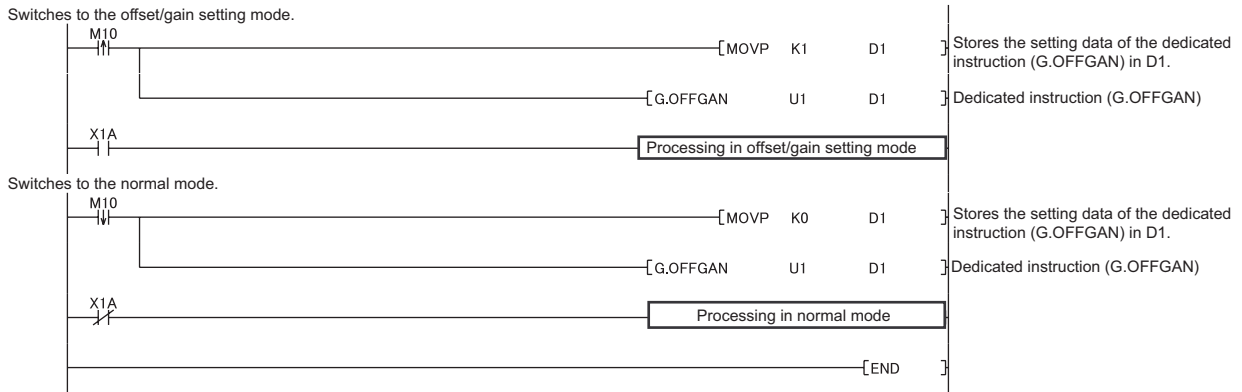

**APPEN  
DIX**

Appendix 5 Dedicated Instruction  
Appendix 5.2 G(P).OFFGAN

# Appendix 5.3 G(P).OGLOAD

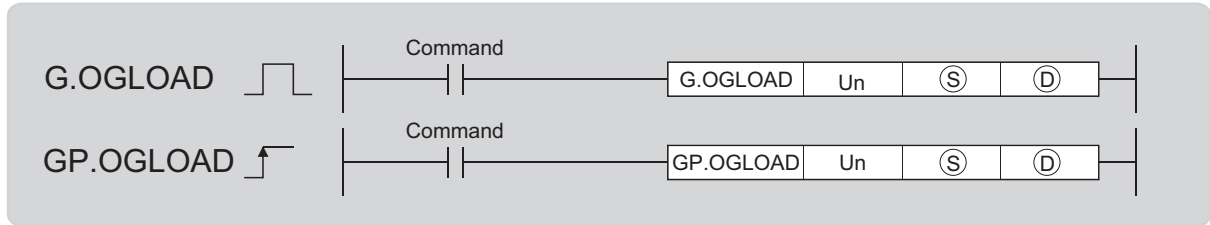

Setting data	Internal device		R, ZR	J□\□		U□\G□	Zn	Constant	Others
	Bit	Word		Bit	Word				
(S)	—	○				—			
(D)		○				—			

## (1) Setting data

Device	Description	Setting range	Data type
Un	Start I/O number of module	0 to FE <sub>H</sub>	BIN 16-bit
(S)	Start number of device where the control data is stored	Within the range of specified device	Device name
(D)	Device to turn ON for one scan after the processing completion of the dedicated instruction. In error completion, (D)+1 also turns ON.	Within the range of specified device	Bit



**(2) Control data \*1**

Device	Item	Setting data	Setting range	Set by										
Ⓢ	System area	—	—	—										
Ⓢ+1	Completion status	The status on instruction completion is stored. 0 : normal completion Other than 0: error completion (error code)	—	System										
Ⓢ+2	Pass data classification setting	Specify the type of offset/gain setting value to read out. 0: voltage 1: current  <div style="display: flex; justify-content: space-around; align-items: center;"> <span>b15</span> <span>b4</span> <span>b3</span> <span>b2</span> <span>b1</span> <span>b0</span> </div> <table style="margin-left: auto; margin-right: auto; border-collapse: collapse;"> <tr> <td style="border: 1px solid black; padding: 2px;">0</td> <td style="border: 1px solid black; padding: 2px;">~</td> <td style="border: 1px solid black; padding: 2px;">~</td> <td style="border: 1px solid black; padding: 2px;">~</td> <td style="border: 1px solid black; padding: 2px;">~</td> <td style="border: 1px solid black; padding: 2px;">0</td> <td style="border: 1px solid black; padding: 2px;">CH4</td> <td style="border: 1px solid black; padding: 2px;">CH3</td> <td style="border: 1px solid black; padding: 2px;">CH2</td> <td style="border: 1px solid black; padding: 2px;">CH1</td> </tr> </table>	0	~	~	~	~	0	CH4	CH3	CH2	CH1	0000 <sub>H</sub> to 000F <sub>H</sub>	User
0	~	~	~	~	0	CH4	CH3	CH2	CH1					
Ⓢ+3	System area	—	—	—										
Ⓢ+4	CH1 Industrial shipment settings offset value	—	—	System										
Ⓢ+5	CH1 Industrial shipment settings gain value	—	—	System										
Ⓢ+6	CH2 Industrial shipment settings offset value	—	—	System										
Ⓢ+7	CH2 Industrial shipment settings gain value	—	—	System										
Ⓢ+8	CH3 Industrial shipment settings offset value	—	—	System										
Ⓢ+9	CH3 Industrial shipment settings gain value	—	—	System										
Ⓢ+10	CH4 Industrial shipment settings offset value	—	—	System										
Ⓢ+11	CH4 Industrial shipment settings gain value	—	—	System										
Ⓢ+12	CH1 User range settings offset value	—	—	System										
Ⓢ+13	CH1 User range settings gain value	—	—	System										
Ⓢ+14	CH2 User range settings offset value	—	—	System										
Ⓢ+15	CH2 User range settings gain value	—	—	System										
Ⓢ+16	CH3 User range settings offset value	—	—	System										
Ⓢ+17	CH3 User range settings gain value	—	—	System										
Ⓢ+18	CH4 User range settings offset value	—	—	System										
Ⓢ+19	CH4 User range settings gain value	—	—	System										

\*1 Configure the setting only for the Pass data classification setting Ⓢ +2.  
When the data is written to the area to be set by system, offset/gain setting value is not correctly read out.

**(3) Functions**

This instruction reads out the offset/gain setting value in the user range setting of the relevant module to CPU module.

The interlock signal of G(P).OGLOAD includes a completion device Ⓢ and a completion status device Ⓢ +1.

**(a) Completion device**

The device turns ON at the END processing for the scan where the G(P).OGLOAD instruction is completed, and turns OFF at the next END processing.

### (b) Completion status indication device

This device turns OFF → ON → OFF depending on the status of the G(P).OGLOAD instruction completion.

- Normal completion: the device is kept to be OFF.
- Error completion: the device turns ON at the END processing for the scan where the G(P).OGLOAD instruction is completed, and turns OFF at the next END processing.

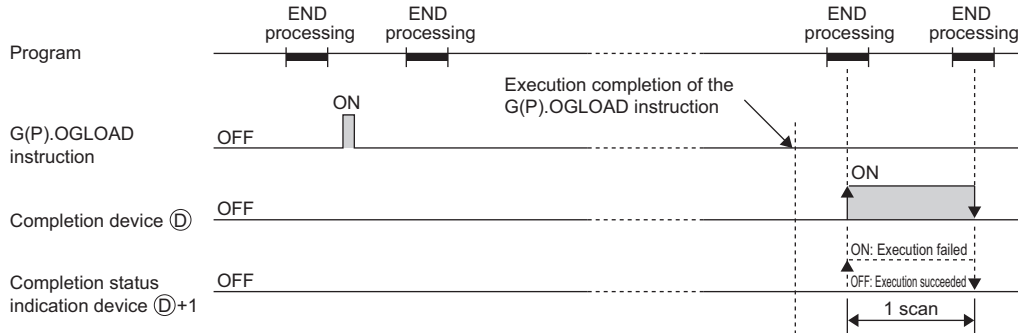

### (4) Errors

The instruction has no errors.

### (5) Program example

The following shows the program to read out the offset/gain setting value of the D/A converter module, installed in I/O number X/Y10 to X/Y1F, by turning ON M11.

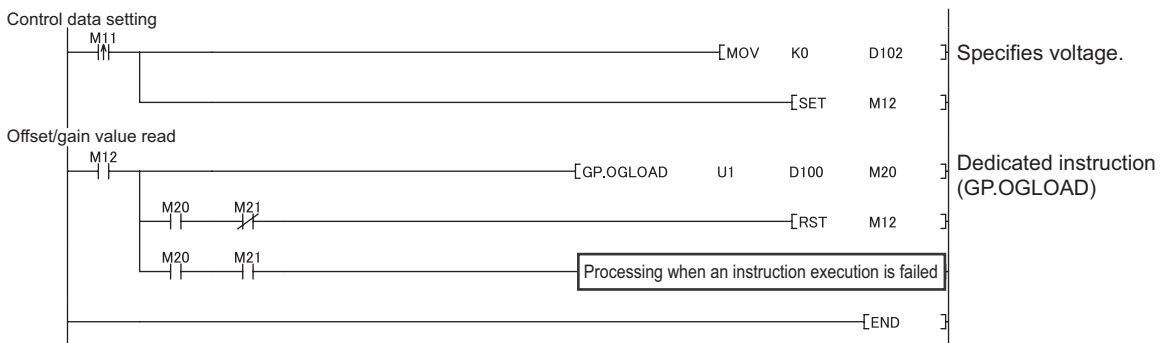

### Point

When performing the dedicated instruction G(P).OGSTOR, the D/A conversion is stopped.  
 Turn OFF → ON → OFF Operating condition setting request (Y9) to restart the D/A conversion.

## Appendix 5.4 G(P).OGSTOR

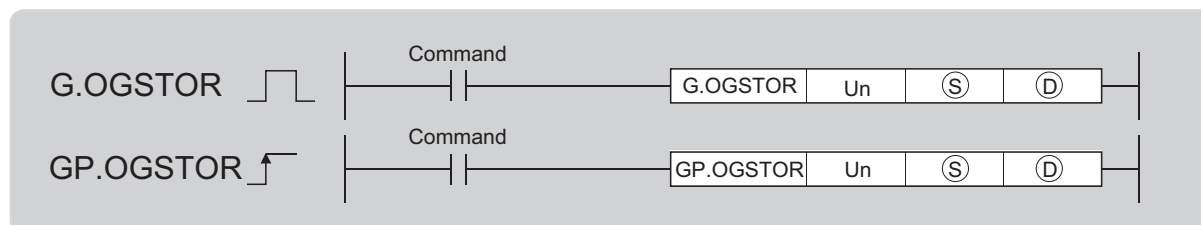

Setting data	Internal device		R, ZR	J□\□		U□\G□	Zn	Constant K, H, \$	Others
	Bit	Word		Bit	Word				
(S)	—	○							
(D)		○							

### (1) Setting data

Device	Description	Setting range	Data type
Un	Start I/O number of module	0 to FE <sub>H</sub>	BIN 16-bit
(S) <sup>*1</sup>	Start number of device where the control data is stored	Within the range of specified device	Device name
(D)	Device to turn ON for one scan after the processing completion of the dedicated instruction. It also makes (D)+1 ON in error completion.	Within the range of specified device	Bit

- \*1 Specify the device specified to (S) on execution of the G(P).OGLOAD instruction.  
Do not change the data which is read out by the G(P).OGLOAD instruction. If the data is changed, the normal operation may not be ensured.

## (2) Control data

Device	Item	Setting data	Setting range	Set by
Ⓢ	System area	—	—	—
Ⓢ+1	Completion status	The status on instruction completion is stored. 0 : normal completion Other than 0: error completion (error code)	—	System
Ⓢ+2	Pass data classification setting	The value which is set for Pass data classification setting Ⓢ +2 by G(P).OGLOAD instruction is stored. 0: voltage 1: current  <div style="display: flex; align-items: center; gap: 5px;"> <span style="font-size: small;">b15</span> <span style="border: 1px solid black; padding: 2px;">0</span> <span style="font-size: small;">~</span> <span style="border: 1px solid black; padding: 2px;">~</span> <span style="font-size: small;">~</span> <span style="border: 1px solid black; padding: 2px;">~</span> <span style="font-size: small;">~</span> <span style="font-size: small;">b4</span> <span style="border: 1px solid black; padding: 2px;">0</span> <span style="font-size: small;">b3</span> <span style="border: 1px solid black; padding: 2px;">CH4</span> <span style="font-size: small;">b2</span> <span style="border: 1px solid black; padding: 2px;">CH3</span> <span style="font-size: small;">b1</span> <span style="border: 1px solid black; padding: 2px;">CH2</span> <span style="font-size: small;">b0</span> <span style="border: 1px solid black; padding: 2px;">CH1</span> </div>	0000 <sub>H</sub> to 000F <sub>H</sub>	System
Ⓢ+3	System area	—	—	—
Ⓢ+4	CH1 Industrial shipment settings offset value	—	—	System
Ⓢ+5	CH1 Industrial shipment settings value	—	—	System
Ⓢ+6	CH2 Industrial shipment settings offset value	—	—	System
Ⓢ+7	CH2 Industrial shipment settings gain value	—	—	System
Ⓢ+8	CH3 Industrial shipment settings offset value	—	—	System
Ⓢ+9	CH3 Industrial shipment settings gain value	—	—	System
Ⓢ+10	CH4 Industrial shipment settings offset value	—	—	System
Ⓢ+11	CH4 Industrial shipment settings gain value	—	—	System
Ⓢ+12	CH1 User range settings offset value	—	—	System
Ⓢ+13	CH1 User range settings gain value	—	—	System
Ⓢ+14	CH2 User range settings offset value	—	—	System
Ⓢ+15	CH2 User range settings gain value	—	—	System
Ⓢ+16	CH3 User range settings offset value	—	—	System
Ⓢ+17	CH3 User range settings gain value	—	—	System
Ⓢ+18	CH4 User range settings offset value	—	—	System
Ⓢ+19	CH4 User range settings gain value	—	—	System

## (3) Functions

- The offset/gain setting value in the user range setting stored in the CPU module is restored to the D/A converter module.
- There are two interlock signals of G(P).OGSTOR: a completion device Ⓣ and a completion status indication device Ⓣ+1.
- The reference accuracy on restoration of offset/gain setting value is lowered three times or less of that of before the restoration.

### (a) Completion device

The device turns ON at the END processing for the scan where the G(P).OGSTOR instruction is completed, and turns OFF at the next END processing.

**(b) Completion status indication device**

This device turns OFF → ON → OFF depending on the status of the G(P).OGSTOR instruction completion.

- Normal completion: the device is kept to be OFF.
- Error completion: the device turns ON at the END processing for the scan where the G(P).OGSTOR instruction is completed, and turns OFF at the next END processing.

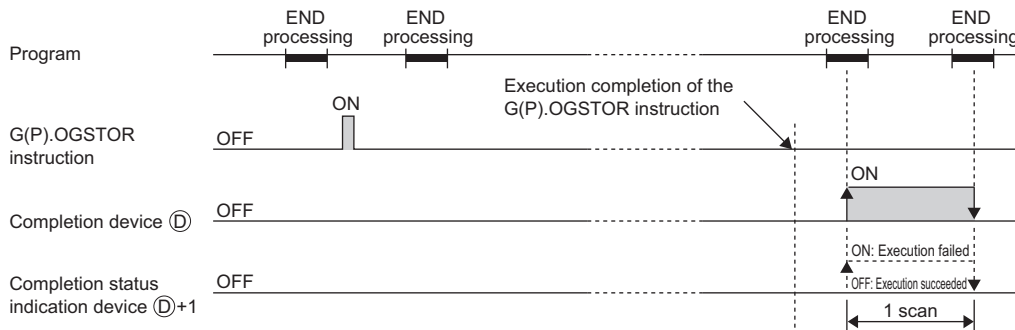

APPEN  
DIX

**(4) Errors**

In the following cases, an error occurs and error code is stored in completion status area (S) +1.

Error code	Description of operation error
161	G(P).OGSTOR instruction is executed in offset/gain setting mode.
162	G(P).OGSTOR instruction is continuously executed.
163	<ul style="list-style-type: none"> <li>• G(P).OGSTOR instruction is executed to the different model from the one to which G(P).OGLOAD instruction is executed.</li> <li>• G(P).OGSTOR instruction has been executed before the execution of G(P).OGLOAD instruction.</li> </ul>

**(5) Program example**

The following shows the programs to write the offset/gain setting value to the D/A converter module, installed in I/O number X/Y10 to X/Y1F, by turning OFF M11.

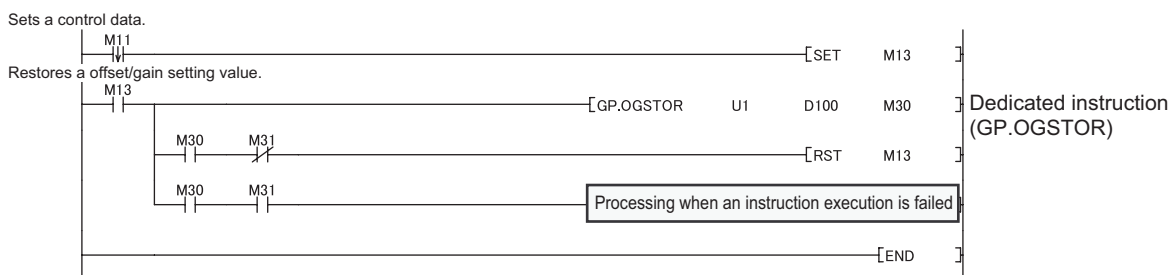

Appendix 5 Dedicated Instruction  
Appendix 5.4 G(P).OGSTOR

# Appendix 6 Checking Serial Number and Function Version

For details on how to check the serial number and function version, refer to the following.

 MELSEC-L CPU Module User's Manual (Hardware Design, Maintenance and Inspection)

# Appendix 7 Differences with Q Series

The following table shows a comparison of the specifications between the L60DA4 and the Q64DAN.

For the function comparison between LCPU and QCPU, refer to the following.

 MELSEC-L CPU Module User's Manual (Hardware Design, Maintenance and Inspection)

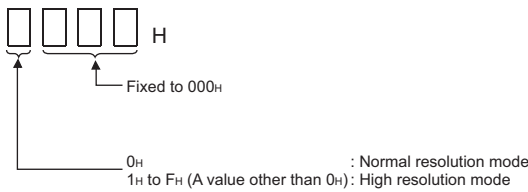
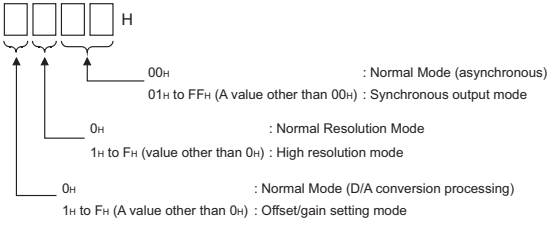
Difference	L60DA4	Q64DAN
Resolution switching function	1 type; 1/20000 (resolution switching function is not installed)	2 types; normal resolution (1/4000) and high resolution (1/12000 or 1/16000)
Synchronous output function	Not available	Available
Switch 4 in switch setting	 <p>0H : Normal resolution mode 1H to FH (A value other than 0H): High resolution mode</p>	 <p>00H : Normal Mode (asynchronous) 01H to FFH (A value other than 00H) : Synchronous output mode 0H : Normal Resolution Mode 1H to FH (value other than 0H) : High resolution mode 0H : Normal Mode (D/A conversion processing) 1H to FH (A value other than 0H) : Offset/gain setting mode</p>

# Appendix 8 When Using GX Developer or GX Configurator-DA

Appendix 8 describes the operating procedure when using GX Developer and GX Configurator-DA.

## (1) Compatible software version

For compatible software version, refer to the following.

 MELSEC-L CPU Module User's Manual (Hardware Design, Maintenance and Inspection)

## Appendix 8.1 Operation of GX Developer

Configure the setting on the following screen when using GX Developer.

Screen name	Application	Reference
I/O assignment	Set the type of module to be installed and the range of I/O signal.	Page 125, Appendix 8.1(1)
Switch setting	Configure the switch setting for an intelligent function module.	Page 126, Appendix 8.1(2)
Offset/gain setting	Configure the setting when using the user range setting for output range.	Page 45, Section 7.5.2 (1)

### (1) I/O assignment

Configure the setting from "I/O assignment" in "PLC parameter".

 Parameter ⇨ [PLC parameter] ⇨ [I/O assignment]

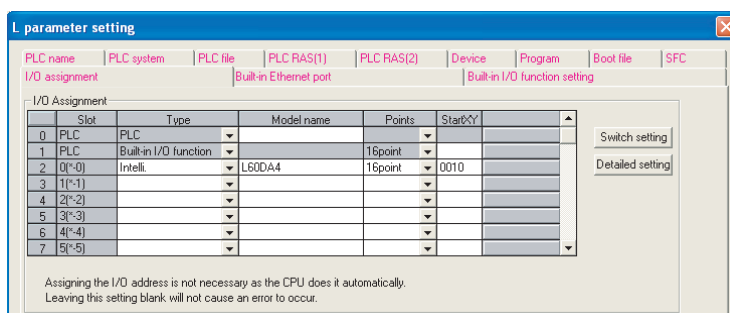

Item	Description
Type	Select "Intelli".
Model name	Enter the model name of the D/A converter module.
Points	Select "16 point".
Start XY	Enter a desired start I/O number of D/A converter module.



## (2) Intelligent function module switch setting

Configure the setting from "Switch setting" in "PLC parameter".

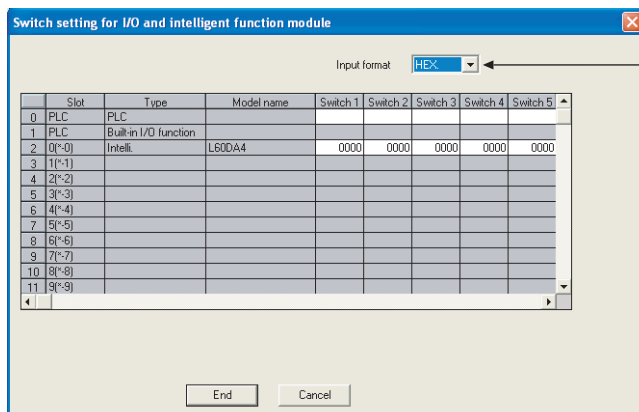
Parameter ⇒ [PLC parameter] ⇒ [I/O assignment] ⇒ Click the  button.

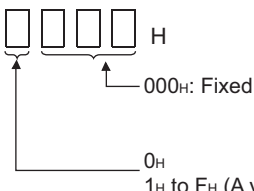

Select "HEX.".

Item	Setting item	
	Analog output range	Output range setting
Switch 1	Output range setting (CH1 to CH4)	
		
	4 to 20mA	0 <sub>H</sub>
	0 to 20mA	1 <sub>H</sub>
	1 to 5V	2 <sub>H</sub>
	0 to 5V	3 <sub>H</sub>
	-10 to 10V	4 <sub>H</sub>
	User range setting	F <sub>H</sub>
Switch 2	0: Fixed (blank)	
Switch 3	HOLD/CLEAR function setting (CH1 to CH4)	
		
	Setting value	HOLD/CLEAR
	0	CLEAR
	1 to F <sub>H</sub> <sup>*1</sup>	HOLD
Switch 4		
	: Normal mode 1 <sub>H</sub> to F <sub>H</sub> (A value other than 0 <sub>H</sub> ) <sup>*1</sup> : Offset-gain setting mode	
Switch 5	0: Fixed (blank) <sup>*2</sup>	

\*1 The operation is the same when any value within the setting range is set.

\*2 If a value other than 0 is written, error: 112 occurs.



# Appendix 8.2 Operation of GX Configurator-DA

When setting the D/A converter module parameter using GX Configurator-DA, the display method such as a setting screen differs from that of GX Works2.

This section describes the screen display method of GX Configurator-DA.

The setting contents are the same as GX Works2. (☞ Page 38, CHAPTER 7)

When using GX Configurator-DA, configure the settings on the following screens.

Screen name	Application
Initial setting	This setting configures the settings such as D/A conversion enable/disable setting.
Auto refresh setting	This setting transfers data in the buffer memory to specified devices.
Monitor/test	This function enables the user to monitor/test the buffer memory and I/O signals, and configure the operating condition setting and offset/gain setting.
FB conversion	This function generates FB automatically from the intelligent function module parameter (initial setting/auto refresh).

APPEN  
DIX

GX Developer screen

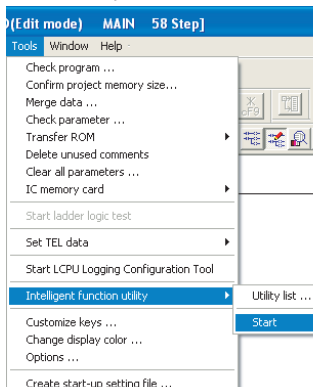

[Tools] - [Intelligent function utility] - [Start]

Screen for selecting a target intelligent function module

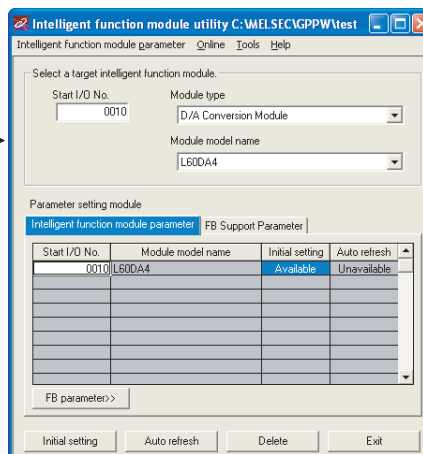

Initial setting

Initial setting screen

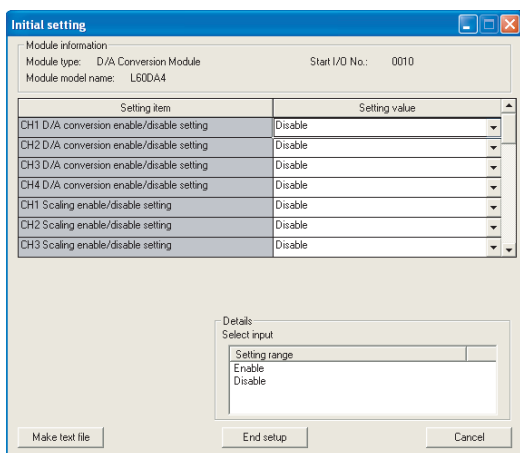

Auto refresh

Auto refresh setting screen

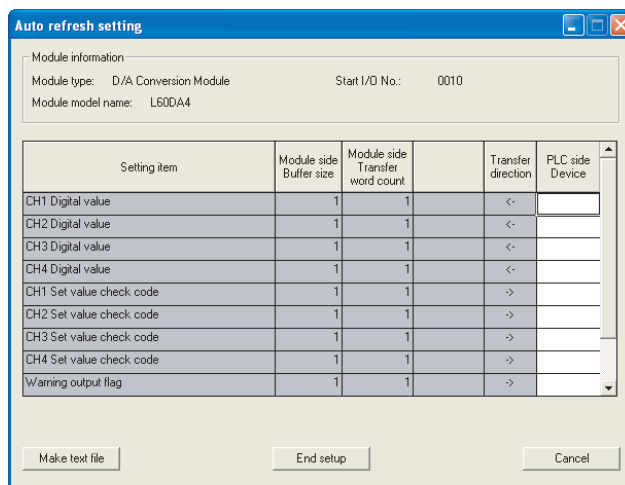

Appendix 8 When Using GX Developer or GX Configurator-DA  
Appendix 8.2 Operation of GX Configurator-DA

1)

[Online] - [Monitor/Test]

<<FB Support Parameter>>tab - FB conversion

Select monitor/test module screen

FB conversion screen

Start I/O No.	Module model name	Initial setting	Auto refresh	FB program name	Title
0010H	L60DA4				

Select a module to be monitored/tested.

Monitor/Test screen

Setting item	Current value	Setting value
DH1 Digital value	0	0
DH2 Digital value	0	0
DH3 Digital value	0	0
DH4 Digital value	0	0
DH1 Set value check code	0000	
DH2 Set value check code	0000	
DH3 Set value check code	0000	
DH4 Set value check code	0000	
DH1 Warning output flag upper limit value	Normal	
DH1 Warning output flag lower limit value	Normal	
DH2 Warning output flag upper limit value	Normal	

# Appendix 9 External Dimensions

The following shows the external dimensions of D/A converter module.

## (1) L60DA4

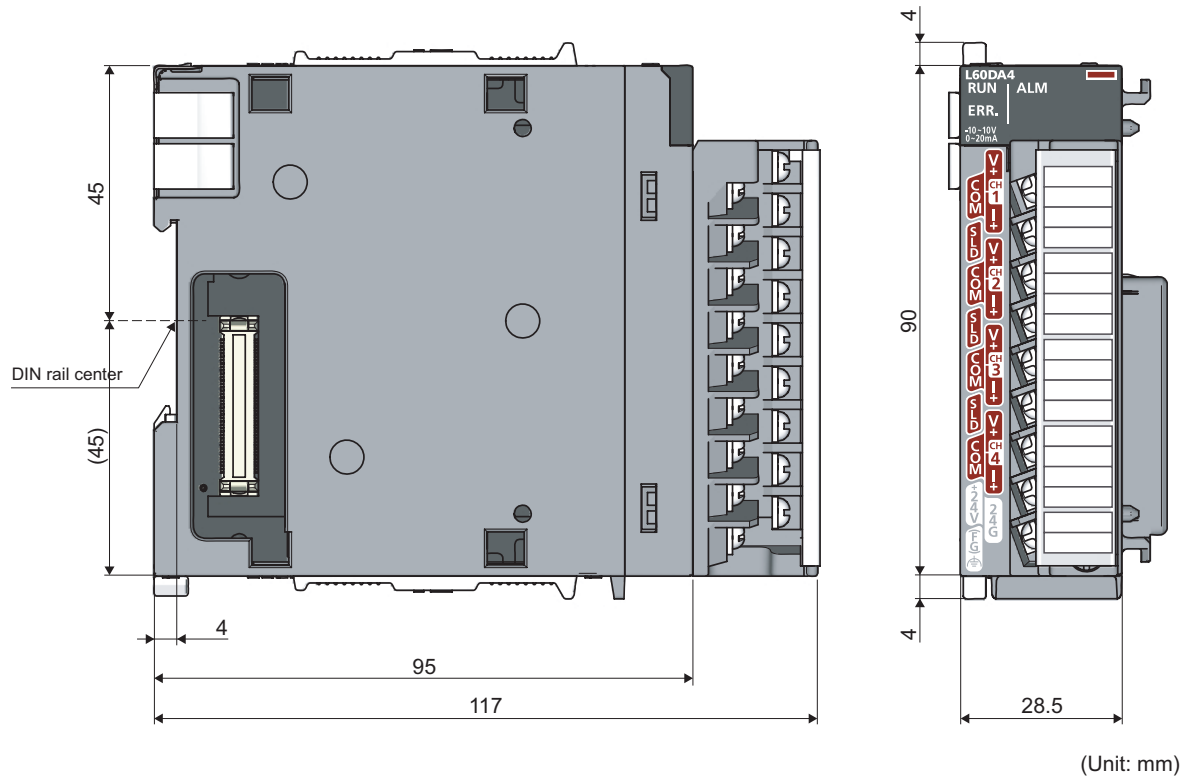

APPEN  
DIX

Appendix 9 External Dimensions

# Memo

---

# INDEX

## A

Addition of modules . . . . .	38
Alarm output function . . . . .	59
Analog output HOLD/CLEAR function . . . . .	50
Analog output test when CPU module is in STOP status . . . . .	52
Auto refresh . . . . .	41

## C

CH1 Industrial shipment settings offset value (Un\G202) to CH4 User range settings gain value (Un\G217) . . . . .	111
Channel change completed flag (XB) . . . . .	100
Channel change request (YB) . . . . .	102
CH□ Digital value (Un\G1 to Un\G4) . . . . .	104
CH□ Output enable/disable flag (Y1 to Y4) . . . . .	102
CH□ Scaling lower limit value (Un\G54, Un\G56, Un\G58, Un\G60) . . . . .	109
CH□ Scaling upper limit value (Un\G55, Un\G57, Un\G59, Un\G61) . . . . .	109
CH□ Set value check code (Un\G11 to Un\G14) . . . . .	105
CH□ Warning output lower limit value (Un\G87, Un\G89, Un\G91, Un\G93) . . . . .	109
CH□ Warning output upper limit value (Un\G86, Un\G88, Un\G90, Un\G92) . . . . .	109
Current output characteristic . . . . .	113

## D

D/A conversion enable/disable function . . . . .	49
D/A conversion enable/disable setting (Un\G0) . . . . .	104
D/A output enable/disable function . . . . .	49

## E

Error clear function . . . . .	64
Error clear request (YF) . . . . .	103
Error flag (XF) . . . . .	101
Error history No. □ (Un\G1810 to Un\G1969) . . . . .	111
Error log function . . . . .	61
External dimensions . . . . .	129
External power supply READY flag (X7) . . . . .	98
External wiring . . . . .	37
For current output . . . . .	37
For voltage output . . . . .	37

## G

Gain value . . . . .	112
----------------------	-----

## H

Hardware LED information . . . . .	97
Hardware switch information . . . . .	97
HOLD/CLEAR function setting (Un\G26) . . . . .	107

## I

I/O assignment . . . . .	125
Intelligent function module switch setting . . . . .	126

## L

Latest error code (Un\G19) . . . . .	105
Latest error code address (Un\G1800) . . . . .	111

## M

Mode switching setting (Un\G158, Un\G159) . . . . .	110
Module error collection function . . . . .	63
Module READY (X0) . . . . .	98

## O

Offset value . . . . .	112
Offset/gain adjustment value specification (Un\G24) . . . . .	106
Offset/gain setting . . . . .	42
Offset/gain setting mode flag (XA) . . . . .	100
Offset/gain setting mode Gain specification (Un\G23) . . . . .	106
Offset/gain setting mode Offset specification (Un\G22) . . . . .	106
Operating condition setting completed flag (X9) . . . . .	99
Operating condition setting request (Y9) . . . . .	102

## P

Parameter setting . . . . .	40
Pass data classification setting (Un\G200) . . . . .	110

## R

Range reference tables . . . . .	69
----------------------------------	----

## S

Saving and restoring offset/gain values . . . . .	65
Scaling enable/disable setting (Un\G53) . . . . .	108
Scaling function . . . . .	54
Set value change completed flag (XC) . . . . .	101
Set value change request (YC) . . . . .	102
Setting range (Un\G20) . . . . .	105
Switch setting . . . . .	39

## U

User range writing request (YA) . . . . .	102
---	-----

## V

Voltage output characteristic . . . . .	112
---	-----

## W

---

Warning output clear request (YE) . . . . .	103
Warning output flag (Un\G48) . . . . .	108
Warning output setting (Un\G47) . . . . .	107
Warning output signal (XE) . . . . .	101

# INSTRUCTION INDEX

---

## G

---

G(P).OFFGAN .....	116
G(P).OGLOAD .....	118
G(P).OGSTOR .....	121

INDEX

# REVISIONS

\*The manual number is given on the bottom left of the back cover.

Print date	*Manual number	Revision
January 2010	SH(NA)-080900ENG-A	First edition
April 2010	SH(NA)-080900ENG-B	<p><b>Partial correction</b></p> <p>SAFETY PRECAUTIONS, COMPLIANCE WITH THE EMC AND LOW VOLTAGE DIRECTIVES, RELEVANT MANUALS, TERMS, CHAPTER 3, Section 3.1, 3.2.1, 3.3, 3.5, CHAPTER 4, Section 5.1, 5.2, Section 6.1, Section 7.1, 7.2, 7.3, 7.4, 7.5, Section 8.3, 8.4, 8.5, 8.6, Section 9.3, 9.4, Section 10.2, CHAPTER 11, Section 11.4, 11.6, APPENDICES 2</p> <p><b>Additions</b></p> <p>Section 5.3, Section 7.5.1, Section 10.3</p> <p><b>Modification</b></p> <p>APPENDICES 8.1 → Section 7.5.2</p>

Japanese manual version SH-080878-C

This manual confers no industrial property rights or any rights of any other kind, nor does it confer any patent licenses. Mitsubishi Electric Corporation cannot be held responsible for any problems involving industrial property rights which may occur as a result of using the contents noted in this manual.

© 2010 MITSUBISHI ELECTRIC CORPORATION



# **Warranty**

Please confirm the following product warranty details before using this product.

## **1. Gratis Warranty Term and Gratis Warranty Range**

If any faults or defects (hereinafter "Failure") found to be the responsibility of Mitsubishi occurs during use of the product within the gratis warranty term, the product shall be repaired at no cost via the sales representative or Mitsubishi Service Company.

However, if repairs are required onsite at domestic or overseas location, expenses to send an engineer will be solely at the customer's discretion. Mitsubishi shall not be held responsible for any re-commissioning, maintenance, or testing on-site that involves replacement of the failed module.

[Gratis Warranty Term]

The gratis warranty term of the product shall be for one year after the date of purchase or delivery to a designated place.

Note that after manufacture and shipment from Mitsubishi, the maximum distribution period shall be six (6) months, and the longest gratis warranty term after manufacturing shall be eighteen (18) months. The gratis warranty term of repair parts shall not exceed the gratis warranty term before repairs.

[Gratis Warranty Range]

- (1) The range shall be limited to normal use within the usage state, usage methods and usage environment, etc., which follow the conditions and precautions, etc., given in the instruction manual, user's manual and caution labels on the product.
- (2) Even within the gratis warranty term, repairs shall be charged for in the following cases.
  1. Failure occurring from inappropriate storage or handling, carelessness or negligence by the user. Failure caused by the user's hardware or software design.
  2. Failure caused by unapproved modifications, etc., to the product by the user.
  3. When the Mitsubishi product is assembled into a user's device, Failure that could have been avoided if functions or structures, judged as necessary in the legal safety measures the user's device is subject to or as necessary by industry standards, had been provided.
  4. Failure that could have been avoided if consumable parts (battery, backlight, fuse, etc.) designated in the instruction manual had been correctly serviced or replaced.
  5. Failure caused by external irresistible forces such as fires or abnormal voltages, and Failure caused by force majeure such as earthquakes, lightning, wind and water damage.
  6. Failure caused by reasons unpredictable by scientific technology standards at time of shipment from Mitsubishi.
  7. Any other failure found not to be the responsibility of Mitsubishi or that admitted not to be so by the user.

## **2. Onerous repair term after discontinuation of production**

- (1) Mitsubishi shall accept onerous product repairs for seven (7) years after production of the product is discontinued.

Discontinuation of production shall be notified with Mitsubishi Technical Bulletins, etc.

- (2) Product supply (including repair parts) is not available after production is discontinued.

## **3. Overseas service**

Overseas, repairs shall be accepted by Mitsubishi's local overseas FA Center. Note that the repair conditions at each FA Center may differ.

## **4. Exclusion of loss in opportunity and secondary loss from warranty liability**

Regardless of the gratis warranty term, Mitsubishi shall not be liable for compensation of damages caused by any cause found not to be the responsibility of Mitsubishi, loss in opportunity, lost profits incurred to the user by Failures of Mitsubishi products, special damages and secondary damages whether foreseeable or not, compensation for accidents, and compensation for damages to products other than Mitsubishi products, replacement by the user, maintenance of on-site equipment, start-up test run and other tasks.

## **5. Changes in product specifications**

The specifications given in the catalogs, manuals or technical documents are subject to change without prior notice.

Microsoft, Windows, Windows NT, and Windows Vista are registered trademarks of Microsoft Corporation in the United States and other countries.

Pentium is a trademark of Intel Corporation in the United States and other countries.

Ethernet is a trademark of Xerox Corporation.

All other company names and product names used in this manual are trademarks or registered trademarks of their respective companies.

SPREAD

Copyright(C) 1996 FarPoint Technologies, Inc.

# MELSEC-L Digital-Analog Converter Module User's Manual

MODEL	L-D/A-U-E
MODEL CODE	13JZ43
SH(NA)-080900ENG-B(1004)MEE	



HEAD OFFICE : TOKYO BUILDING, 2-7-3 MARUNOUCHI, CHIYODA-KU, TOKYO 100-8310, JAPAN  
NAGOYA WORKS : 1-14, YADA-MINAMI 5-CHOME, HIGASHI-KU, NAGOYA, JAPAN

When exported from Japan, this manual does not require application to the  
Ministry of Economy, Trade and Industry for service transaction permission.

Specifications subject to change without notice.

**HEADQUARTERS**

MITSUBISHI ELECTRIC EUROPE B.V. **EUROPE**  
 German Branch  
 Gothaer Straße 8  
**D-40880 Ratingen**  
 Phone: +49 (0)2102 / 486-0  
 Fax: +49 (0)2102 / 486-1120

MITSUBISHI ELECTRIC EUROPE B.V.-org.sl. **CZECH REP.**  
 Czech Branch  
 Avenir Business Park, Radlická 714/113a  
**CZ-158 00 Praha 5**  
 Phone: +420 - 251 551 470  
 Fax: +420 - 251-551-471

MITSUBISHI ELECTRIC EUROPE B.V. **FRANCE**  
 French Branch  
 25, Boulevard des Bouvets  
**F-92741 Nanterre Cedex**  
 Phone: +33 (0)1 / 55 68 55 68  
 Fax: +33 (0)1 / 55 68 57 57

MITSUBISHI ELECTRIC EUROPE B.V. **IRELAND**  
 Irish Branch  
 Westgate Business Park, Ballymount  
**IRL-Dublin 24**  
 Phone: +353 (0)1 4198800  
 Fax: +353 (0)1 4198890

MITSUBISHI ELECTRIC EUROPE B.V. **ITALY**  
 Italian Branch  
 Viale Colleoni 7  
**I-20041 Agrate Brianza (MB)**  
 Phone: +39 039 / 60 53 1  
 Fax: +39 039 / 60 53 312

MITSUBISHI ELECTRIC EUROPE B.V. **POLAND**  
 Poland Branch  
 Krakowska 50  
**PL-32-083 Balice**  
 Phone: +48 (0)12 / 630 47 00  
 Fax: +48 (0)12 / 630 47 01

MITSUBISHI ELECTRIC EUROPE B.V. **RUSSIA**  
 52, bid. 3 Kosmodamienskaya nab 8 floor  
**RU-115054 Moscow**  
 Phone: +7 495 721-2070  
 Fax: +7 495 721-2071

MITSUBISHI ELECTRIC EUROPE B.V. **SPAIN**  
 Spanish Branch  
 Carretera de Rubí 76-80  
**E-08190 Sant Cugat del Vallés (Barcelona)**  
 Phone: 902 131121 // +34 935653131  
 Fax: +34 935891579

MITSUBISHI ELECTRIC EUROPE B.V. **UK**  
 UK Branch  
 Travellers Lane  
**UK-Hatfield, Herts. AL10 8XB**  
 Phone: +44 (0)1707 / 27 61 00  
 Fax: +44 (0)1707 / 27 86 95

MITSUBISHI ELECTRIC CORPORATION **JAPAN**  
 Office Tower "Z" 14 F  
 8-12,1 chome, Harumi Chuo-Ku  
**Tokyo 104-6212**  
 Phone: +81 3 622 160 60  
 Fax: +81 3 622 160 75

MITSUBISHI ELECTRIC AUTOMATION, Inc. **USA**  
 500 Corporate Woods Parkway  
**Vernon Hills, IL 60061**  
 Phone: +1 847 478 21 00  
 Fax: +1 847 478 22 53

**EUROPEAN REPRESENTATIVES**

GEVA **AUSTRIA**  
 Wiener Straße 89  
**AT-2500 Baden**  
 Phone: +43 (0)2252 / 85 55 20  
 Fax: +43 (0)2252 / 488 60

TECHNIKON **BELARUS**  
 Oktyabrskaya 19, Off. 705  
**BY-220030 Minsk**  
 Phone: +375 (0)17 / 210 46 26  
 Fax: +375 (0)17 / 210 46 26

ESCO DRIVES & AUTOMATION **BELGIUM**  
 Culliganlaan 3  
**BE-1831 Diegem**  
 Phone: +32 (0)2 / 717 64 30  
 Fax: +32 (0)2 / 717 64 31

Koning & Hartman b.v. **BELGIUM**  
 Woluwelaan 31  
**BE-1800 Vilvoorde**  
 Phone: +32 (0)2 / 257 02 40  
 Fax: +32 (0)2 / 257 02 49

INEA RBT d.o.o. **BOSNIA AND HERZEGOVINA**  
 Aleja Lipa 56  
**BA-71000 Sarajevo**  
 Phone: +387 (0)33 / 921 164  
 Fax: +387 (0)33 / 524 539

AKHNATON **BULGARIA**  
 4, Andrej Ljapchev Blvd., PO Box 21  
**BG-1756 Sofia**  
 Phone: +359 (0)2 / 817 6000  
 Fax: +359 (0)2 / 97 44 06 1

INEA RBT d.o.o. **CROATIA**  
 Losinjska 4 a  
**HR-10000 Zagreb**  
 Phone: +385 (0)1 / 36 940 -01 / -02 / -03  
 Fax: +385 (0)1 / 36 940 -03

AutoCont C.S. s.r.o. **CZECH REPUBLIC**  
 Technologická 374/6  
**CZ-708 00 Ostrava-Pustkovce**  
 Phone: +420 595 691 150  
 Fax: +420 595 691 199

Beijer Electronics A/S **DENMARK**  
 Lykkegårdsvej 17  
**DK-4000 Roskilde**  
 Phone: +45 (0)46 / 75 76 66  
 Fax: +45 (0)46 / 75 56 26

Beijer Electronics Eesti OÜ **ESTONIA**  
 Pärnu mnt.160i  
**EE-11317 Tallinn**  
 Phone: +372 (0)6 / 51 81 40  
 Fax: +372 (0)6 / 51 81 49

Beijer Electronics OY **FINLAND**  
 Peltoie 37  
**FIN-28400 Ulvila**  
 Phone: +358 (0)207 / 463 540  
 Fax: +358 (0)207 / 463 541

UTEKO **GREECE**  
 5, Mavrogenous Str.  
**GR-18542 Piraeus**  
 Phone: +30 211 / 1206 900  
 Fax: +30 211 / 1206 999

MELTRADE Kft. **HUNGARY**  
 Fertő utca 14.  
**HU-1107 Budapest**  
 Phone: +36 (0)1 / 431-9726  
 Fax: +36 (0)1 / 431-9727

Beijer Electronics SIA **LATVIA**  
 Rītausmas iela 23  
**LV-1058 Rīga**  
 Phone: +371 (0)784 / 2280  
 Fax: +371 (0)784 / 2281

Beijer Electronics UAB **LITHUANIA**  
 Savanoriu Pr. 187  
**LT-02300 Vilnius**  
 Phone: +370 (0)5 / 232 3101  
 Fax: +370 (0)5 / 232 2980

**EUROPEAN REPRESENTATIVES**

ALFATRADE Ltd. **MALTA**  
 99, Paola Hill  
**Malta- Paola PLA 1702**  
 Phone: +356 (0)21 / 697 816  
 Fax: +356 (0)21 / 697 817

INTEHSIS srl **MOLDOVA**  
 bld. Traian 23/1  
**MD-2060 Kishinev**  
 Phone: +373 (0)22 / 66 4242  
 Fax: +373 (0)22 / 66 4280

HIFLEX AUTOM.TECHNIEK B.V. **NETHERLANDS**  
 Wolweverstraat 22  
**NL-2984 CD Ridderkerk**  
 Phone: +31 (0)180 - 46 60 04  
 Fax: +31 (0)180 - 44 23 55

Koning & Hartman b.v. **NETHERLANDS**  
 Haarlerbergweg 21-23  
**NL-1101 CH Amsterdam**  
 Phone: +31 (0)20 / 587 76 00  
 Fax: +31 (0)20 / 587 76 05

Beijer Electronics AS **NORWAY**  
 Postboks 487  
**NO-3002 Drammen**  
 Phone: +47 (0)32 / 24 30 00  
 Fax: +47 (0)32 / 84 85 77

Fonseca S.A. **PORTUGAL**  
 R. João Francisco do Casal 87/89  
**PT - 3801-997 Aveiro, Esgueira**  
 Phone: +351 (0)234 / 303 900  
 Fax: +351 (0)234 / 303 910

Sirius Trading & Services srl **ROMANIA**  
 Aleea Lacul Morii Nr. 3  
**RO-060841 Bucuresti, Sector 6**  
 Phone: +40 (0)21 / 430 40 06  
 Fax: +40 (0)21 / 430 40 02

INEA RBT d.o.o. **SERBIA**  
 Izletnička 10  
**SER-113000 Smederevo**  
 Phone: +381 (0)26 / 615 401  
 Fax: +381 (0)26 / 615 401

SIMAP s.r.o. **SLOVAKIA**  
 Jána Derku 1671  
**SK-911 01 Trenčín**  
 Phone: +421 (0)32 743 04 72  
 Fax: +421 (0)32 743 75 20

PROCONT, spol. s r.o. **SLOVAKIA**  
 Prešov  
 Kúpeľná 1/A  
**SK-080 01 Prešov**  
 Phone: +421 (0)51 7580 611  
 Fax: +421 (0)51 7580 650

INEA RBT d.o.o. **SLOVENIA**  
 Stegne 11  
**SI-1000 Ljubljana**  
 Phone: +386 (0)1 / 513 8116  
 Fax: +386 (0)1 / 513 8170

Beijer Electronics AB **SWEDEN**  
 Box 426  
**SE-20124 Malmö**  
 Phone: +46 (0)40 / 35 86 00  
 Fax: +46 (0)40 / 93 23 01

Omni Ray AG **SWITZERLAND**  
 Im Schörl 5  
**CH-8600 Dübendorf**  
 Phone: +41 (0)44 / 802 28 80  
 Fax: +41 (0)44 / 802 28 28

GTS **TURKEY**  
 Bayraktar Bulvarı Nutuk Sok. No:5  
**TR-34775 Yukarı Dudullu-Ümraniye-İSTANBUL**  
 Phone: +90 (0)216 526 39 90  
 Fax: +90 (0)216 526 3995

CSC Automation Ltd. **UKRAINE**  
 4-B, M. Raskovoyi St.  
**UA-02660 Kiev**  
 Phone: +380 (0)44 / 494 33 55  
 Fax: +380 (0)44 / 494-33-66

Systemgroup **UKRAINE**  
 2 M. Krivonosy St.  
**UA-03680 Kiev**  
 Phone: +380 (0)44 / 490 92 29  
 Fax: +380 (0)44 / 248 88 68

**EURASIAN REPRESENTATIVES**

TOO Kazpromavtomatika **KAZAKHSTAN**  
 Ul. Zhambyla 28  
**KAZ-100017 Karaganda**  
 Phone: +7 7212 / 50 10 00  
 Fax: +7 7212 / 50 11 50

**MIDDLE EAST REPRESENTATIVES**

ILAN & GAVISH Ltd. **ISRAEL**  
 24 Shenkar St., Kiryat Arie  
**IL-49001 Petah-Tiqva**  
 Phone: +972 (0)3 / 922 18 24  
 Fax: +972 (0)3 / 924 0761

GIRIT CELADON LTD **ISRAEL**  
 12 H'aomanut Street  
**IL-42505 Netanya**  
 Phone: +972 (0)9 / 863 39 80  
 Fax: +972 (0)9 / 885 24 30

CEG INTERNATIONAL **LEBANON**  
 Cebaco Center/Block A Autostrade DORA  
**Lebanon - Beirut**  
 Phone: +961 (0)1 / 240 430  
 Fax: +961 (0)1 / 240 438

**AFRICAN REPRESENTATIVE**

CBI Ltd. **SOUTH AFRICA**  
 Private Bag 2016  
**ZA-1600 Isando**  
 Phone: + 27 (0)11 / 977 0770  
 Fax: + 27 (0)11 / 977 0761