

MITSUBISHI

Mitsubishi Programmable Controller

MELSEC *L*series

MELSEC-L Analog-Digital Converter Module User's Manual

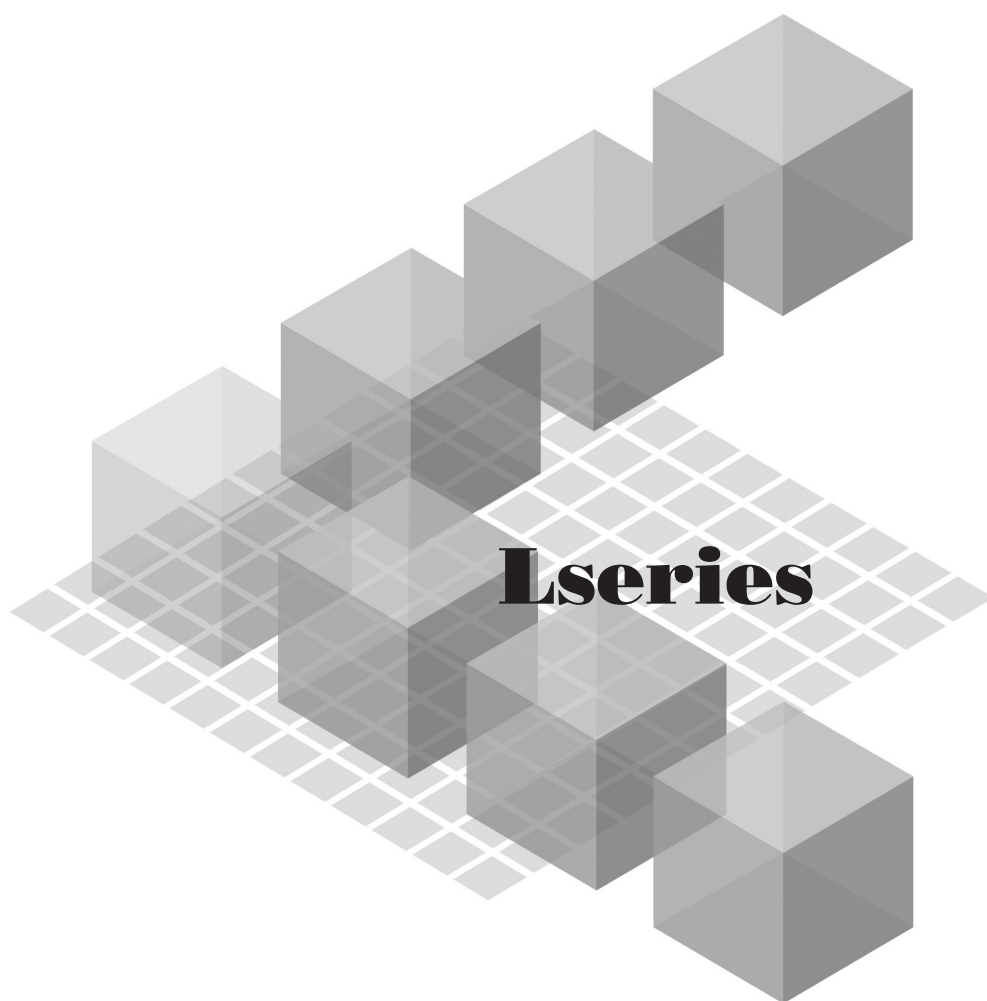

-L60AD4

MODEL

● SAFETY PRECAUTIONS ●

(Read these precautions before using this product.)

Before using this product, please read this manual and the relevant manuals carefully and pay full attention to safety to handle the product correctly.

The precautions given in this manual are concerned with this product only. For the safety precautions of the programmable controller system, refer to the user's manual for the CPU module used.

In this manual, the safety precautions are classified into two levels: "⚠ WARNING" and "⚠ CAUTION".



Indicates that incorrect handling may cause hazardous conditions, resulting in death or severe injury.

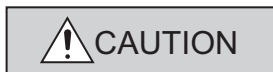

Indicates that incorrect handling may cause hazardous conditions, resulting in minor or moderate injury or property damage.

Under some circumstances, failure to observe the precautions given under "⚠ CAUTION" may lead to serious consequences.

Observe the precautions of both levels because they are important for personal and system safety.

Make sure that the end users read this manual and then keep the manual in a safe place for future reference.

[Design Precautions]

⚠ WARNING

- Do not write any data to the "system area" and "write-protect area" (R) of the buffer memory in the intelligent function module.
Also, do not use any "use prohibited" signals as an output signal from the programmable controller CPU to the intelligent function module.
Doing so may cause malfunction of the programmable controller system.

[Design Precautions]

⚠ CAUTION

- Do not install the control lines or communication cables together with the main circuit lines or power cables.
Keep a distance of 100mm or more between them. Failure to do so may result in malfunction due to noise.

[Installation Precautions]

WARNING

- Shut off the external power supply for the system in all phases before connecting or removing a module. Failure to do so may result in electric shock or cause the module to fail or malfunction.

[Installation Precautions]

CAUTION

- Use the programmable controller in an environment that meets the general specifications in the manual "Safety Guidelines", the manual supplied with the CPU module or head module. Failure to do so may result in electric shock, fire, malfunction, or damage to or deterioration of the product.
- To interconnect modules, engage the respective connectors and securely lock the module joint levers. Incorrect interconnection may cause malfunction, failure, or drop of the module.
- Tighten the screw within the specified torque range.
Undertightening can cause drop of the screw, short circuit or malfunction.
Overtightening can damage the screw and/or module, resulting in drop, short circuit, or malfunction.
- Do not directly touch any conductive parts and electronic components of the module. Doing so can cause malfunction or failure of the module.

[Wiring Precautions]

WARNING

- After installation and wiring, attach the included terminal cover to the module before turning it on for operation. Failure to do so may result in electric shock.

[Wiring Precautions]

CAUTION

- Ground the FG terminal to the protective ground conductor dedicated to the programmable controller. Failure to do so may result in electric shock or malfunction.
- Tighten the terminal block screw within the specified torque range. Undertightening can cause short circuit, fire, or malfunction.
Overtightening can damage the screw and/or module, resulting in drop, short circuit, fire, or malfunction.
- Prevent foreign matter such as dust or wire chips from entering the module. Such foreign matter can cause a fire, failure, or malfunction.
- A protective film is attached to the top of the module to prevent foreign matter, such as wire chips, from entering the module during wiring. Do not remove the film during wiring. Remove it for heat dissipation before system operation.

[Wiring Precautions]

CAUTION

- Mitsubishi programmable controllers must be installed in control panels. Connect the main power supply to the power supply module in the control panel through a relay terminal block. Wiring and replacement of a power supply module must be performed by qualified maintenance personnel with knowledge of protection against electric shock. For wiring methods, refer to the MELSEC-L CPU Module User's Manual (Hardware Design, Maintenance and Inspection).

[Startup and Maintenance Precautions]

WARNING

- Do not touch any terminal while power is on. Doing so will cause electric shock or malfunction.
- Shut off the external power supply for the system in all phases before cleaning the module or retightening the terminal block screw. Failure to do so may result in electric shock.

[Startup and Maintenance Precautions]

CAUTION

- Do not disassemble or modify the module. Doing so may cause failure, malfunction, injury, or a fire.
- Shut off the external power supply for the system in all phases before connecting or removing a module. Failure to do so may cause the module to fail or malfunction.
- Tighten the terminal block screw within the specified torque range. Undertightening can cause drop of the component or wire, short circuit, or malfunction. Overtightening can damage the screw and/or module, resulting in drop, short circuit, or malfunction.
- After the first use of the product (module, display unit, and terminal block), the number of connections/disconnections is limited to 50 times (in accordance with IEC 61131-2). Exceeding the limit may cause malfunction.
- Before handling the module, touch a conducting object such as a grounded metal to discharge the static electricity from the human body. Failure to do so may cause the module to fail or malfunction.

[Disposal Precautions]

CAUTION

- When disposing of this product, treat it as industrial waste.

● CONDITIONS OF USE FOR THE PRODUCT ●

- (1) Mitsubishi programmable controller ("the PRODUCT") shall be used in conditions;
 - i) where any problem, fault or failure occurring in the PRODUCT, if any, shall not lead to any major or serious accident; and
 - ii) where the backup and fail-safe function are systematically or automatically provided outside of the PRODUCT for the case of any problem, fault or failure occurring in the PRODUCT.

- (2) The PRODUCT has been designed and manufactured for the purpose of being used in general industries.

MITSUBISHI SHALL HAVE NO RESPONSIBILITY OR LIABILITY (INCLUDING, BUT NOT LIMITED TO ANY AND ALL RESPONSIBILITY OR LIABILITY BASED ON CONTRACT, WARRANTY, TORT, PRODUCT LIABILITY) FOR ANY INJURY OR DEATH TO PERSONS OR LOSS OR DAMAGE TO PROPERTY CAUSED BY the PRODUCT THAT ARE OPERATED OR USED IN APPLICATION NOT INTENDED OR EXCLUDED BY INSTRUCTIONS, PRECAUTIONS, OR WARNING CONTAINED IN MITSUBISHI'S USER, INSTRUCTION AND/OR SAFETY MANUALS, TECHNICAL BULLETINS AND GUIDELINES FOR the PRODUCT.

("Prohibited Application")

Prohibited Applications include, but not limited to, the use of the PRODUCT in;

- Nuclear Power Plants and any other power plants operated by Power companies, and/or any other cases in which the public could be affected if any problem or fault occurs in the PRODUCT.
- Railway companies or Public service purposes, and/or any other cases in which establishment of a special quality assurance system is required by the Purchaser or End User.
- Aircraft or Aerospace, Medical applications, Train equipment, transport equipment such as Elevator and Escalator, Incineration and Fuel devices, Vehicles, Manned transportation, Equipment for Recreation and Amusement, and Safety devices, handling of Nuclear or Hazardous Materials or Chemicals, Mining and Drilling, and/or other applications where there is a significant risk of injury to the public or property.

Notwithstanding the above, restrictions Mitsubishi may in its sole discretion, authorize use of the PRODUCT in one or more of the Prohibited Applications, provided that the usage of the PRODUCT is limited only for the specific applications agreed to by Mitsubishi and provided further that no special quality assurance or fail-safe, redundant or other safety features which exceed the general specifications of the PRODUCTS are required. For details, please contact the Mitsubishi representative in your region.

INTRODUCTION

Thank you for purchasing the Mitsubishi MELSEC-L series programmable controllers.

This manual describes the functions and programming of an analog-digital converter module (hereafter abbreviated as A/D converter module).

Before using this product, please read this manual and the relevant manuals carefully and develop familiarity with the functions and performance of the MELSEC-L series programmable controller to handle the product correctly.

When applying the program examples introduced in this manual to the actual system, ensure the applicability and confirm that it will not cause system control problems.

■Relevant module: L60AD4

Remark

Unless otherwise specified, this manual describes the program examples in which the I/O numbers of X/Y00 to X/Y0F are assigned for an A/D converter module.

For I/O number assignment, refer to the following.

 MELSEC-L CPU Module User's Manual (Function Explanation, Program Fundamentals)

Operating procedures are explained using GX Works2. When using GX Developer or GX Configurator-AD, refer to the following.

- When using GX Developer or GX Configurator-AD ( Page 226, Appendix 9)

COMPLIANCE WITH EMC AND LOW VOLTAGE DIRECTIVES

(1) Method of ensuring compliance

To ensure that Mitsubishi programmable controllers maintain EMC and Low Voltage Directives when incorporated into other machinery or equipment, certain measures may be necessary. Please refer to the Safety Guidelines Please refer to the manual included with the CPU module or head module.

The CE mark on the side of the programmable controller indicates compliance with EMC and Low Voltage Directives.

(2) Additional measures

No additional measures are necessary for the compliance of this product with the EMC and Low Voltage Directives.

RELEVANT MANUALS

(1) CPU module user's manual

Manual name <manual number (model code)>	Description
MELSEC-L CPU Module User's Manual (Hardware Design, Maintenance and Inspection) <SH-080890ENG, 13JZ36>	Specifications of the CPU modules, power supply modules, display unit, branch module, extension module, SD memory cards, and batteries, information on how to establish a system, maintenance and inspection, and troubleshooting
MELSEC-L CPU Module User's Manual (Function Explanation, Program Fundamentals) <SH-080889ENG, 13JZ35>	Functions and devices of the CPU module, and programming

(2) Head module user's manual

Manual name <manual number (model code)>	Description
MELSEC-L CC-Link IE Field Network Head Module User's Manual <SH-080919ENG, 13JZ48>	Specifications for a head module, procedures before operation, system configuration, installation and wiring, settings, and troubleshooting

(3) Operating manual

Manual name <manual number (model code)>	Description
GX Works2 Version 1 Operating Manual (Common) <SH-080779ENG, 13JU63>	System configuration, parameter settings, and online operations (common to Simple project and Structured project) of GX Works2
GX Developer Version 8 Operating Manual <SH-080373E, 13JU41>	Operating methods of GX Developer, such as programming, printing, monitoring, and debugging

CONTENTS

SAFETY PRECAUTIONS	1
CONDITIONS OF USE FOR THE PRODUCT	4
INTRODUCTION	5
COMPLIANCE WITH EMC AND LOW VOLTAGE DIRECTIVES	6
RELEVANT MANUALS	7
MANUAL PAGE ORGANIZATION	11
TERMS	14
PACKING LIST	14
<hr/>	
CHAPTER 1 A/D CONVERTER MODULE	15
<hr/>	
1.1 Application	15
1.2 Features	16
<hr/>	
CHAPTER 2 PART NAMES	17
<hr/>	
CHAPTER 3 SPECIFICATIONS	19
<hr/>	
3.1 General Specifications	19
3.2 Performance Specifications	20
3.2.1 Number of parameter settings	22
3.3 Function List	23
3.4 I/O Signal List	25
3.5 List of Buffer Memory Addresses	26
<hr/>	
CHAPTER 4 PROCEDURES BEFORE STARTING THE OPERATION	39
<hr/>	
CHAPTER 5 SYSTEM CONFIGURATION	41
<hr/>	
5.1 Overall System Configuration	41
5.2 Applicable System	42
5.3 Restrictions When A/D Converter Module is Connected to Head Module	42
<hr/>	
CHAPTER 6 INSTALLATION AND WIRING	43
<hr/>	
6.1 Installation Environment and Installation Position	43
6.2 Terminal Block	44
6.3 Wiring	46
6.4 External Wiring	47
<hr/>	
CHAPTER 7 VARIOUS SETTINGS	48
<hr/>	
7.1 Addition of Modules	48
7.2 Switch Setting	49
7.3 Parameter Setting	50
7.4 Auto Refresh	53
7.5 Offset/Gain Setting	54
7.5.1 Setting from GX Works2 "Offset/Gain Setting"	54
7.5.2 Setting from a program	57

CHAPTER 8 FUNCTIONS **61**

8.1	Processing Each Function	61
8.2	A/D Conversion Enable/Disable Function	63
8.3	A/D Conversion Method	63
8.4	Input Range Extended Mode Function	67
8.5	Conversion Speed Switch Function	68
8.6	Maximum and Minimum Values Hold Function	68
8.7	Input Signal Error Detection Function	69
8.8	Input Signal Error Detection Extension Function	74
8.9	Warning Output Function (Process Alarm)	77
8.10	Scaling Function	80
8.11	Shift Function	86
8.12	Digital Clipping Function	90
8.13	Difference Conversion Function	94
8.14	Logging Function	98
8.15	Flow Amount Integration Function	110
8.16	Error Log Function	119
8.17	Module Error Collection Function	122
8.18	Error Clear Function	123
8.19	Saving and Restoring Offset/Gain Values	124

CHAPTER 9 DISPLAY UNIT **129**

9.1	Display Unit	129
9.2	Menu Transition	129
9.3	List of Setting Value Change Screens	131
9.4	Checking and Clearing Errors	138

CHAPTER 10 PROGRAMMING **140**

10.1	Procedure for Programming	140
10.2	When Using the Module in a Standard System Configuration	141
10.3	When A/D Converter Module is Connected to Head Module	148

CHAPTER 11 TROUBLESHOOTING **156**

11.1	Checking on the Module Detailed Information	157
11.2	Checking by Latest Error Code (Un\G19)	158
11.3	Checking on the Module Error Collection Function	158
11.4	Error Code List	159
11.5	Alarm Code List	163
11.6	Troubleshooting	164
11.7	Checking the Status of the A/D Converter Module by the System Monitor	166

APPENDICES **167**

Appendix 1 Details of I/O Signals	167
Appendix 1.1 Input signal	167
Appendix 1.2 Output signal	172
Appendix 2 Details of Buffer Memory Addresses	174
Appendix 3 I/O Conversion Characteristic of A/D Conversion	203
Appendix 4 A/D Conversion Accuracy	208
Appendix 5 Dedicated Instruction	209
Appendix 5.1 Instruction list	209
Appendix 5.2 G(P).OFFGAN	210
Appendix 5.3 G(P).OGLOAD	212
Appendix 5.4 G(P).OGSTOR	216
Appendix 6 Checking Serial Number and Function Version	220
Appendix 7 Addition and Change of Functions	220
Appendix 7.1 Addition of functions	220
Appendix 7.2 Change of functions	220
Appendix 8 Differences with Q Series	223
Appendix 8.1 Precautions for Applying Q Series Sequence Program	224
Appendix 9 When Using GX Developer or GX Configurator-AD	226
Appendix 9.1 Operation of GX Developer	226
Appendix 9.2 Operation of GX Configurator-AD	228
Appendix 10 External Dimensions	231

INDEX **233**

INSTRUCTION INDEX **235**

REVISIONS	236
WARRANTY	237

MANUAL PAGE ORGANIZATION

In this manual, pages are organized and the symbols are used as shown below.

The following illustration is for explanation purpose only, and should not be referred to as an actual documentation.

The diagram illustrates the organization of a manual page, specifically Chapter 7, Section 7.1.1. The page content includes:

- Chapter Header:** CHAPTER 7 VARIOUS SETTINGS
- Section Header:** 7.1.1 Setting method
- Sub-sections:** (1) Setting parameters, (a) Operating procedure
- Numbered List:** 1. Open the "PLC Parameter" dialog box. 2. Select the "I/O Assignment" tab.
- Image:** A screenshot of the "Parameter Settings" dialog box showing a table with columns for Slot, Type, Description, Points, Start XY, and Switch Setting.
- Table:** A table with columns: Item, Description, Reference.

Item	Description	Reference
Type	Select the type of the connected module.	Page 74, Section 7.1.2
Model Name	Select the model name of the connected module.	Page 74, Section 7.1.3
Points	Set the number of points assigned to each slot.	Page 74, Section 7.1.4
Start XY	Specify a start I/O number for each slot.	Page 74, Section 7.1.5
Switch Setting	Configure the switch setting of the built-in I/O or intelligent function modules.	Page 74, Section 7.1.6
Default Setting	Set the following: - Error Time Output Mode - PLC Operation Mode at HW Error - I/O Response Time	Page 75, Section 7.1.7
- Text:** Setting "Start XY" enables modification on the start I/O numbers assigned to connected modules. Example: When "1000" is specified in "Start XY" to the slot where a 16-point module is connected, the assignment range of an input module is changed to X1000 to X100F. Reference: MELSEC-L CPU Module User's Manual (Function Explanation, Program Fundamentals).
- Point:** Set the type of the connected module in "Type". Setting a different type results in "SP.LIMIT LAV ERR". For the intelligent function module, the I/O points must also be the same in addition to the I/O assignment setting. Reference: Page 30, Section 4.2.2.
- Remark:** When an intelligent module is connected, I/O assignment can be omitted by selecting connected modules from "Intelligent Function Module" in the Project window.

Annotations on the left side explain symbols used in the manual:

- "" is used for screen names and items.
- 1. shows operating procedures.
- ☞ shows mouse operations.*1
- [] is used for items in the menu bar and the project window.
- Ex. shows setting or operating examples.
- 📖 shows reference manuals.
- 👉 shows reference pages.

Annotations on the right side explain symbols used in the manual:

- The chapter of the current page is shown.
- The section of the current page is shown.
- Point shows notes that requires attention.
- Remark shows useful information.

*1 The mouse operation example is provided below. (For GX Works2)

The screenshot shows the MELSOFT Series GX Works2 (Unset Project) - [[PRG] MAIN] interface. The annotations point to the following elements:

- Menu bar:** An example shows the mouse cursor clicking on [Online] in the menu bar, followed by [Write to PLC...]. The instruction is: Select [Online] on the menu bar, and then select [Write to PLC...].
- View selection area:** An example shows the mouse cursor clicking on [Project] in the view selection area, followed by [Parameter] and [PLC Parameter]. The instruction is: Select [Project] from the view selection area to open the Project window. In the Project window, expand [Parameter] and select [PLC Parameter].

Pages describing instructions are organized as shown below.

The following illustration is for explanation purpose only, and should not be referred to as an actual documentation.

Instruction name

6.4.2 Disconnecting a connection (SP.SOCCLDSE)

Execution condition of the instruction

Structure of the instruction in the ladder mode

Shows the devices applicable to the instruction

Setting data	Internal device		JIC□		UDIGD	Zn	Constant K, H	Others
	Bit	Word	Bit	Word				
Ⓔ	—	○	○	—	—	—	○	—
Ⓕ	—	△ ¹⁾	△ ¹⁾	—	—	—	—	—
Ⓖ	△ ¹⁾	—	△ ¹⁾	—	—	—	—	—

*1: File registers set for each local device or program cannot be used.

Setting side
User : Device value is set by the user.
System: Device value is set by the CPU module.

Descriptions of setting data and data type

Setting data	Description	Set by	Data type
UD	Dummy	—	Character string
Ⓔ	Connection number (Setting range: 1 to 16)	User	BIN 16-bit
Ⓕ	Start number of the device from which control data are stored	System	Device name
Ⓖ	Start number of the device which turns on for one scan upon completion of the instruction Ⓖ+1 also turns on when failed.	System	Bit

Descriptions of control data (if any)

Device	Item	Description	Setting range	Set by
Ⓔ+0	System area	—	—	—
Ⓔ+1	Completion status	Completion status is stored 0000+: Completed Other than 0000+: Failed (Error code)	—	System

63

Detailed descriptions of the instruction

(3) Function

This instruction closes a connection specified in Ⓔ. (Disconnection of a connection)
The result of the SP.SOCCLDSE instruction can be checked with the completion device, Ⓔ + 0 and Ⓔ + 1.

- Completion device Ⓔ + 0
Turns on in the END processing of a scan after completion of the SP.SOCCLDSE instruction, and turns off in the next END processing.
- Completion device Ⓔ + 1
Turns on or off according to the result of the SP.SOCCLDSE instruction.

State	Description
When completed	Remains off.
When failed	Turns on in the END processing of a scan after completion of the SP.SOCCLDSE instruction, and turns off in the next END processing.

Conditions for the error and error codes

(4) Error

A detection of an operation error turns on the Error flag (SM0) and a corresponding error code is stored in S00 when:

- The connection number specified for Ⓔ is other than 1 to 16. (Error code: 4101)
- The device numbers specified for Ⓕ and Ⓖ exceed the device point range. (Error code: 4101)
- An invalid device is specified. (Error code: 4004)

Simple program example(s) and descriptions of the devices used

(5) Program example

When M2000 is turned on or when the connected device disconnects connection No.1, connection No.1 is disconnected by the following program.

• Device used

Device number	Application
S01282	Open completion signal
S01284	Open request signal
D000	SP.SOCCLDSE instruction control data
M2000	SP.SOCCLDSE instruction completion device





• Program

```

SD1282 AND SD1284 CPLD M181 1 Processing for disconnection of
M2000 SD1282 M2000 SP.SOCCLDSE "UD" K1 D000 M200 2 Connection No.1 close
M181 M2000 SET M210 3 Setting SP.SOCCLDSE
M2000 M2000 SET M200 4 Normal completion
M2000 M2000 SET M202 5 Error completion
M2000 M210 RST M210 6 Resetting SP.SOCCLDSE
END
  
```

64

- Instructions can be executed under the following conditions.

Execution condition	Any time	During on	On the rising edge	During off	On the falling edge
Symbol	No symbol				

- The following devices can be used.

Setting data	Internal device (system, user)		File register	Link direct device J□\□		Intelligent function module U□\G□	Index register Zn	Constant ^{*3}	Others ^{*3}
	Bit	Word		Bit	Word				
Applicable device ^{*1}	X, Y, M, L, SM, F, B, SB, FX, FY ^{*2}	T, ST, C, D, W, SD, SW, FD, @□	R, ZR	-		U□\G□	Z	K, H, E, \$	P, I, J, U, D, X, DY, N, BL, TR, BLIS, V

*1 For details on each device, refer to the following.

 MELSEC-L CPU Module User's Manual (Function Explanation, Program Fundamentals)

*2 FX and FY can be used for bit data only, and FD for word data only.

*3 In the "Constant" and "Others" columns, a device(s) that can be set for each instruction is shown.

- The following data types can be used.

Data type	Description
Bit	Bit data or the start number of bit data
BIN 16-bit	16-bit binary data or the start number of word device
BIN 32-bit	32-bit binary data or the start number of double-word device
BCD 4-digit	Four-digit binary-coded decimal data
BCD 8-digit	Eight-digit binary-coded decimal data
Real number	Floating-point data
Character string	Character string data
Device name	Device name data

TERMS

Unless otherwise specified, this manual uses the following terms.

Term	Description
A/D converter module	Another term for the MELSEC-L series analog-digital converter module
Head module	Abbreviation for the LJ72GF15-T2 CC-Link IE Field Network head module
Display unit	A liquid crystal display to be attached to the CPU module
Programming tool	Generic term for GX Works2 and GX Developer
Factory default setting	Generic term for analog input ranges of 0 to 10V, 0 to 5V, 1 to 5V, -10 to 10V, 0 to 20mA, and 4 to 20mA
GX Works2	Product name of the software package for the MELSEC programmable controllers
GX Developer	
GX Configurator-AD	A setting and monitoring tool added in GX Developer (for A/D converter modules)
Buffer memory	The memory of an intelligent function module used to store data (such as setting values and monitored values) for communication with a CPU module.

PACKING LIST

The following items are included in the package of this product. Before use, check that all the items are included.

L60AD4

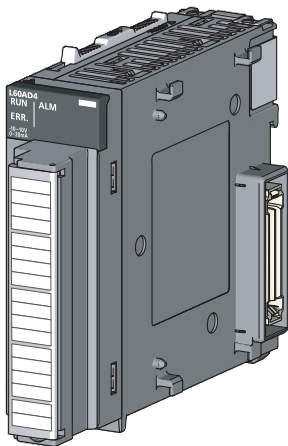

L60AD4

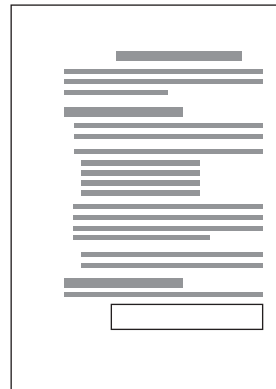

Before Using the Product

CHAPTER 1 A/D CONVERTER MODULE

This chapter describes the applications and features of the A/D converter module.

1.1 Application

This module converts the analog value input from external devices to the digital output value, and inputs the converted data to the CPU module. By converting the data, which has been processed through the A/D converter module, to a digital data, the input information can be sent to the CPU module.

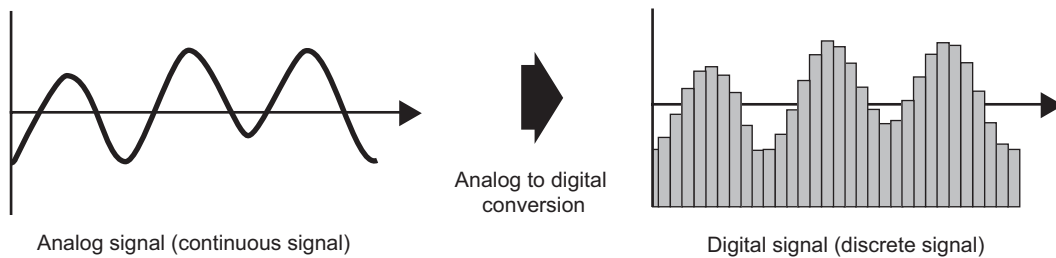

The A/D converter module enables works as follows.

Connect the module to the control valve to measure the flow

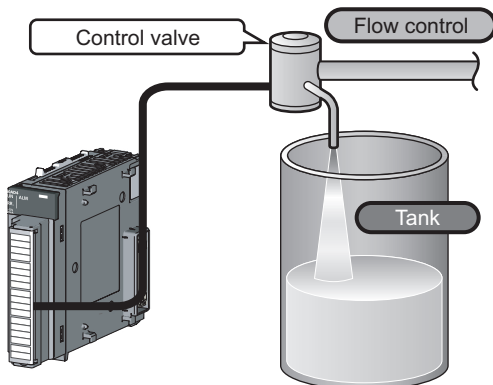

Connect the module to the power conditioning equipment to measure the heating temperature of the heater or others

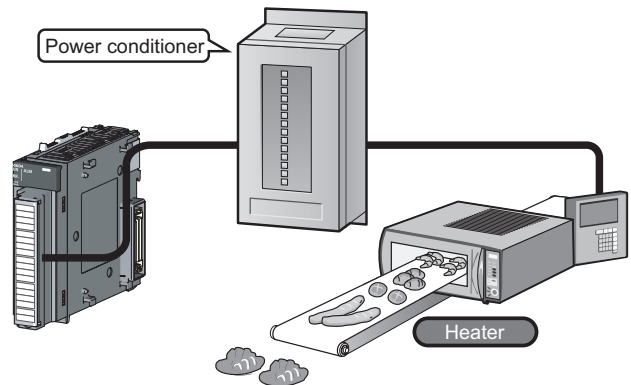

1.2 Features

(1) Response by high-speed conversion

The high-speed conversion of 20 μ s/channel is achieved.

(2) Detailed control by high resolution

In all analog input ranges, the high resolution of 1/20000 is achieved.

(3) Reliability by high accuracy

The accuracy for the maximum value of the digital output value is $\pm 0.1\%$ ($25\pm 5^{\circ}\text{C}$), $\pm 0.2\%$ (0 to 55°C).

(4) Operation of digital output value by each function

The scaling function, shift function, digital clipping function and difference conversion function can represent the digital output value in a numeric value easy to understand according to the use environment.

(5) Comparing/monitoring the measurement target

By using the input signal error detection function, input range extended mode function, or alarm output function (process alarm), the statuses of connected devices can be monitored easily.

(6) Logging function

An analysis of data collected by logging function increases maintainability of used system.

(7) Flow amount integration function

The flow amount integration function executes the integral processing of input (instantaneous flow amount) from a flow meter and easily calculates the flow amount in a certain period. By registering/outputting the calculated flow amount, system operation can be improved and man-hours for programming can be reduced.

(8) Easy setting with GX Works2

Programming is reduced since the initial setting or auto refresh setting can be configured on the screen. In addition, setting status and operation status of modules can be checked easily.

CHAPTER 2 PART NAMES

The following table shows part names of the A/D converter module.

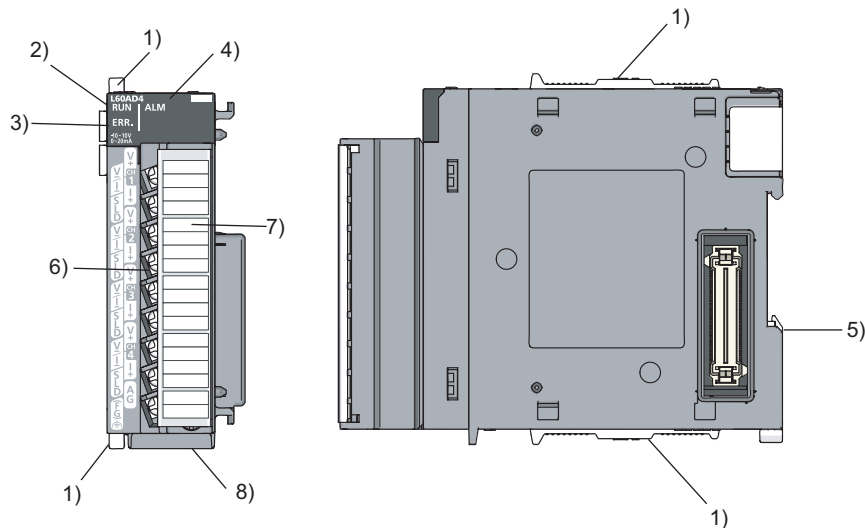

Number	Name	Description
1)	Module joint levers	Levers for connecting modules
2)	RUN LED (green)	Displays the operating status of the A/D converter module. On: The module is operating normally. Flashing: In the offset/gain setting mode Off: The 5V power off or watchdog timer error has occurred.
3)	ERR. LED (red)	Displays the errors and status of the A/D converter module. On: an error has occurred except for error code: 112* ¹ Flashing: Error code: 112 has occurred.* ¹ Off: The module is operating normally.
4)	ALM LED (red)	Displays the alarm status of the A/D converter module. On: Alarm (process alarm) is occurring* ² Flashing: Input signal error detection is occurring Off: The module is operating normally.* ²
5)	DIN rail hook	A hook used to mount the module to a DIN rail
6)	Terminal block	18-pin screw terminal block for connecting input signal lines of such as external devices
7)	Terminal block cover	Covers for preventing electric shock while the power is on
8)	Serial number display	Displays the serial number printed on the rating plate.

*1 Error Code List (☞ Page 159, Section 11.4)

*2 Alarm Code List (☞ Page 163, Section 11.5)

Memo

CHAPTER 3 SPECIFICATIONS

This chapter describes general specifications, performance specifications, function list, list of I/O signals and list of buffer memory address.

3.1 General Specifications

For the general specifications of the A/D converter module, refer to the following.

 The manual "Safety Guidelines", the manual supplied with the a CPU module or head module

3.2 Performance Specifications

The following table shows the performance specifications of the A/D converter module.

Item		Model				
		L60AD4				
Number of analog input points		4 points (4 channels)				
Analog input	Voltage	-10 to 10 VDC (input resistance 1M Ω)				
	Current	0 to 20mADC (input resistance 250 Ω)				
Digital output		-20480 to 20479				
		When using the scaling function	-32768 to 32767			
I/O characteristics, resolution*1		Analog input range		Digital output value	Resolution	
		Voltage	0 to 10V		0 to 20000	500 μ V
			0 to 5V			250 μ V
			1 to 5V			200 μ V
			-10 to 10V		-20000 to 20000	500 μ V
			1 to 5V (Extended mode)		-5000 to 22500	200 μ V
			User range setting		-20000 to 20000	307 μ V*2
		Current	0 to 20mA		0 to 20000	1000nA
			4 to 20mA			800nA
			4 to 20mA (Extended mode)		-5000 to 22500	800nA
			User range setting		-20000 to 20000	1230nA*2
		Accuracy (accuracy for the maximum value of the digital output value)*3	Ambient temperature 25 \pm 5 $^{\circ}$ C	Within \pm 0.1% (\pm 20digit)		
Ambient temperature 0 to 55 $^{\circ}$ C	Within \pm 0.2% (\pm 40digit)					
Conversion speed*4*5*6		High-speed: 20 μ s/channel Medium speed: 80 μ s/channel Low speed: 1ms/channel				
Absolute maximum input		Voltage: \pm 15V, Current: 30mA*7				
Offset/gain setting count*8		Up to 50000 counts				
Isolation method		Between I/O terminals and programmable controller power supply: photocoupler isolation Between input channels: no isolation				
Dielectric withstand voltage		Between I/O terminals and programmable controller power supply: 500VACrms for 1 minute				
Insulation resistance		Between I/O terminals and programmable controller power supply: 500VDC 10M Ω or higher				
Number of occupied I/O points		16 points (I/O assignment: Intelligent 16 points)				
Connected terminal		18-point terminal block				
Applicable wire size		0.3 to 0.75mm ²				
Applicable solderless terminal		R1.25-3 (solderless terminals with sleeve are not usable)				
Internal current consumption (5VDC)		0.52A				
Weight		0.19kg				

- *1 For details on the I/O conversion characteristics, refer to the following.
I/O conversion characteristic of A/D conversion (👉 Page 203, Appendix 3)
- *2 Maximum resolution in the user range setting.

- *3 Except when receiving noise influence.
- *4 The default value is 80 μ s/channel.
- *5 The logging function can be used only in the middle speed (80 μ s/channel) or low speed (1ms/channel).
- *6 The flow amount integration function can be used only in the low speed (1ms/channel).
- *7 This is a momentary current value which does not cause damage to internal resistors of the module. The maximum input current value for constant application is 24mA.
- *8 If the number of offset/gain settings exceeds 50000 times, an error occurs.

3.2.1 Number of parameter settings

Set the initial setting of A/D converter module and the parameter setting of auto refresh setting so that the number of parameters, including these of other intelligent function modules, does not exceed the number of parameters that can be set in the CPU module or the head module.

For the maximum number of parameters that can be set in the CPU module or the head module (maximum number of parameter settings), refer to the following.

 MELSEC-L CPU Module User's Manual (Hardware Design, Maintenance and Inspection)

 MELSEC-L CC-Link IE Field Network Head Module User's Manual

(1) Number of A/D converter module parameters

For A/D converter modules, the following number of parameters can be set per module.

Target module	Initial setting	Auto refresh setting
L60AD4	12	75 (maximum number of settings)

(2) Checking method

The maximum number of parameter settings and the number of parameter settings set for the intelligent function module can be checked with the following operation.

-  Project window ⇒ [Intelligent Function Module] ⇒ Right-click
- ⇒ [Intelligent Function Module Parameter List]

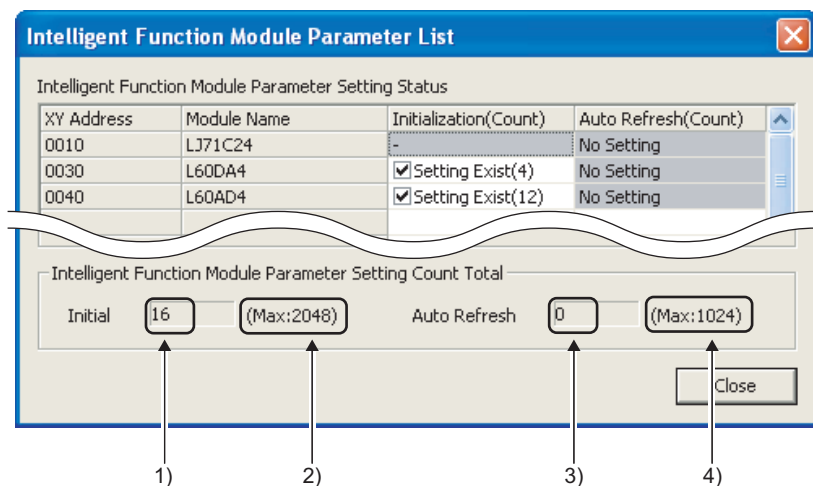

No.	Description
1)	The total number of parameters in the initial settings selected on the dialog box
2)	The maximum number of parameter settings in the initial settings
3)	The total number of parameters in the auto refresh settings selected on the dialog box
4)	The maximum number of parameter settings in the auto refresh settings

3.3 Function List

The following is the function list of the A/D converter module.

Item		Description	Reference	
A/D conversion enable/disable function		Sets whether to enable or disable A/D conversion for each channel. Disabling the A/D conversion for unused channels reduces the conversion cycles.	Page 63, Section 8.2	
A/D conversion method	Sampling processing	The A/D converter module executes the A/D conversion of the analog input value sequentially and stores the digital output value to the buffer memory.	Page 63, Section 8.3 (1)	
	Averaging processing	Time average	The A/D converter module executes the A/D conversion for set time, and stores the average of the total value excluding the maximum and the minimum values to the buffer memory. The number of processing time within the setting time changes depending on the number of channels used (the number of channels set to A/D conversion enabled).	Page 64, Section 8.3 (2)(a)
		Count average	The A/D converter module executes the A/D conversion for set time, and stores the average of the total value excluding the maximum and the minimum values to the buffer memory. Time for the count average value stored in the buffer memory changes depending on the used channel numbers (the number of channels specified to A/D conversion enable).	Page 64, Section 8.3 (2)(b)
		Moving average	The A/D converter module averages digital output values of set number of times which are measured every sampling cycle, and stores them in the buffer memory.	Page 65, Section 8.3 (2)(c)
Range switching function		The input range to use can be selected from the following ranges: <ul style="list-style-type: none"> • Factory default range (4 to 20mA, 0 to 20mA, 1 to 5V, 0 to 5V, -10 to 10V, 0 to 10V) • User range (User range setting) Extended mode range (4 to 20mA (Extended mode), 1 to 5V (Extended mode))	Page 49, Section 7.2	
Offset/gain setting function		This function compensates for errors in digital output values.	Page 54, Section 7.5	
Conversion speed switch function		The conversion speed can be selected from 20 μ s, 80 μ s or 1ms.	Page 68, Section 8.5	
Input range extended mode function		The input range can be extended. By combining this function with the input signal error detection function, simple disconnection detection can be executed.	Page 67, Section 8.4	
Maximum value/minimum value hold function		The A/D converter module stores the maximum and minimum values of the scaling values (digital operation values) for each channel to the buffer memory.	Page 68, Section 8.6	
Input signal error detection function		This function detects the analog input value which exceeds the setting range.	Page 69, Section 8.7	
Input signal error detection extension function		The detection method of the input signal error detection function can be extended. Use this function to detect the input signal error only in the lower limit or upper limit, or to execute the disconnection detection.	Page 74, Section 8.8	
Warning output function (process alarm)		This function outputs alarm when a digital output value is in the range set in advance.	Page 77, Section 8.9	
Scaling function		The A/D converter module scale-converts the output digital value to the set range of the scaling upper limit value and scaling lower limit value. This omits the programming of the scale conversion.	Page 80, Section 8.10	

Item	Description	Reference
Shift function	The A/D converter module adds the set shifting amount to conversion value to the scaling value (digital operation value) and stores in the buffer memory. Fine adjustment can be performed easily when the system starts.	Page 86, Section 8.11
Digital clipping function	When the input voltage or current exceeds the input range, the maximum value of the scaling value (digital operation value) can be set to 20000, and the minimum value can be set to 0 or -20000.	Page 90, Section 8.12
Difference conversion function	This function subtracts the difference conversion reference value from the scaling value (digital operation value) and stores the acquired value in the buffer memory.	Page 94, Section 8.13
Logging function	This function logs the digital output value or scaling value (digital operation value). The data of 10000 points can be logged for each channel.	Page 98, Section 8.14
Flow amount integration function	This function performs the A/D conversion of analog input value (voltage or current) from a source such as a flow meter and integrates the digital output value.	Page 110, Section 8.15
Error log function	The function stores up to latest 16 recodes of errors and alarms occurred in the A/D converter module to the buffer memory.	Page 119, Section 8.16
Module error collection function	This function collects errors and alarms occurred in the A/D converter module and stores to the CPU module or the head module.	Page 122, Section 8.17
Error clear function	Clearing the error from the system monitor at error occurrence is possible.	Page 123, Section 8.18
Saving and restoring offset/gain values	The offset/gain value of the user range setting can be saved or restored.	Page 124, Section 8.19

3.4 I/O Signal List

The following shows the list of the A/D converter module I/O signals.

For the details of I/O signals, refer to the followings.

- Details of I/O signals (☞ Page 167, Appendix 1)

Input signal		Output signal	
Device number	Signal name	Device number	Signal name
X0	Module READY	Y0	Use prohibited
X1	Use prohibited	Y1	
X2		Y2	
X3		Y3	
X4		Y4	
X5		Y5	
X6		Y6	
X7		Y7	
X8	Warning output signal	Y8	
X9	Operating condition setting completed flag	Y9	Operating condition setting request
XA	Offset/gain setting mode flag	YA	User range write request
XB	Channel change completed flag	YB	Channel change request
XC	Input signal error detection signal	YC	Use prohibited
XD	Maximum value/minimum value reset completed flag	YD	Maximum value/minimum value reset request
XE	A/D conversion completed flag	YE	Use prohibited
XF	Error flag	YF	Error clear request

Point

The I/O number (X/Y) described above shows the case that the start I/O number of the A/D converter module is set to "0".

3.5 List of Buffer Memory Addresses

The following shows the list of the A/D converter module buffer memory.

For details of buffer memory addresses, refer to the following.

- Details of buffer memory addresses (☞ Page 174, Appendix 2)

Point

Do not write data to the system area and the area where the data cannot be written from the program in the buffer memory. Writing data to these areas may lead the module to malfunction.

(1) Un\G0 to Un\G1799

Address (decimal)	Address (hexadecimal)	Name	Default *1	Read/Write *2
0	0 _H	A/D conversion enable/disable setting	0000 _H	R/W
1	1 _H	CH1 Time Average/ Count Average/Moving Average	0	R/W
2	2 _H	CH2 Time Average/ Count Average/Moving Average	0	R/W
3	3 _H	CH3 Time Average/ Count Average/Moving Average	0	R/W
4	4 _H	CH4 Time Average/ Count Average/Moving Average	0	R/W
5 to 8	5 _H to 8 _H	System area	—	—
9	9 _H	Averaging process setting (used to replace Q64AD)	0000 _H	R/W
10	A _H	A/D conversion completed flag	0000 _H	R
11	B _H	CH1 Digital output value	0	R
12	C _H	CH2 Digital output value	0	R
13	D _H	CH3 Digital output value	0	R
14	E _H	CH4 Digital output value	0	R
15 to 18	F _H to 12 _H	System area	—	—
19	13 _H	Latest error code	0	R
20	14 _H	Setting range	0000 _H	R
21	15 _H	System area	-	-
22	16 _H	Offset/gain setting mode Offset specification	0000 _H	R/W
23	17 _H	Offset/gain setting mode Gain specification	0000 _H	R/W
24	18 _H	Averaging process setting	0000 _H	R/W
25	19 _H	System area	—	—
26	1A _H	Conversion speed setting	0001 _H	R/W
27	1B _H	Input signal error detection extension setting	0000 _H	R/W
28	1C _H	System area	—	—
29	1D _H	Digital clipping enable/disable setting	000F _H	R/W
30	1E _H	CH1 Maximum value	0	R
31	1F _H	CH1 Minimum value	0	R

Address (decimal)	Address (hexadecimal)	Name	Default *1	Read/Write *2
32	20 _H	CH2 Maximum value	0	R
33	21 _H	CH2 Minimum value	0	R
34	22 _H	CH3 Maximum value	0	R
35	23 _H	CH3 Minimum value	0	R
36	24 _H	CH4 Maximum value	0	R
37	25 _H	CH4 Minimum value	0	R
38 to 46	26 _H to 2E _H	System area	—	—
47	2F _H	Input signal error detection setting	000F _H	R/W
48	30 _H	Warning output setting	000F _H	R/W
49	31 _H	Input signal error detection flag	0000 _H	R
50	32 _H	Warning output flag (Process alarm)	0000 _H	R
51 to 52	33 _H to 34 _H	System area	—	—
53	35 _H	Scaling enable/disable setting	000F _H	R/W
54	36 _H	CH1 Scaling value (digital operation value)	0	R
55	37 _H	CH2 Scaling value (digital operation value)	0	R
56	38 _H	CH3 Scaling value (digital operation value)	0	R
57	39 _H	CH4 Scaling value (digital operation value)	0	R
58 to 61	3A _H to 3D _H	System area	—	—
62	3E _H	CH1 Scaling lower limit value	0	R/W
63	3F _H	CH1 Scaling upper limit value	0	R/W
64	40 _H	CH2 Scaling lower limit value	0	R/W
65	41 _H	CH2 Scaling upper limit value	0	R/W
66	42 _H	CH3 Scaling lower limit value	0	R/W
67	43 _H	CH3 Scaling upper limit value	0	R/W
68	44 _H	CH4 Scaling lower limit value	0	R/W
69	45 _H	CH4 Scaling upper limit value	0	R/W
70 to 85	46 _H to 55 _H	System area	—	—
86	56 _H	CH1 Process alarm lower lower limit value	0	R/W
87	57 _H	CH1 Process alarm lower upper limit value	0	R/W
88	58 _H	CH1 Process alarm upper lower limit value	0	R/W
89	59 _H	CH1 Process alarm upper upper limit value	0	R/W
90	5A _H	CH2 Process alarm lower lower limit value	0	R/W
91	5B _H	CH2 Process alarm lower upper limit value	0	R/W
92	5C _H	CH2 Process alarm upper lower limit value	0	R/W
93	5D _H	CH2 Process alarm upper upper limit value	0	R/W

Address (decimal)	Address (hexadecimal)	Name	Default *1	Read/Write *2
94	5E _H	CH3 Process alarm lower lower limit value	0	R/W
95	5F _H	CH3 Process alarm lower upper limit value	0	R/W
96	60 _H	CH3 Process alarm upper lower limit value	0	R/W
97	61 _H	CH3 Process alarm upper upper limit value	0	R/W
98	62 _H	CH4 Process alarm lower lower limit value	0	R/W
99	63 _H	CH4 Process alarm lower upper limit value	0	R/W
100	64 _H	CH4 Process alarm upper lower limit value	0	R/W
101	65 _H	CH4 Process alarm upper upper limit value	0	R/W
102 to 141	66 _H to 8D _H	System area	—	—
142	8E _H	CH1 Input signal error detection setting value	50	R/W
143	8F _H	CH2 Input signal error detection setting value	50	R/W
144	90 _H	CH3 Input signal error detection setting value	50	R/W
145	91 _H	CH4 Input signal error detection setting value	50	R/W
146 to 149	92 _H to 95 _H	System area	—	—
150	96 _H	CH1 Shifting amount to conversion value	0	R/W
151	97 _H	CH2 Shifting amount to conversion value	0	R/W
152	98 _H	CH3 Shifting amount to conversion value	0	R/W
153	99 _H	CH4 Shifting amount to conversion value	0	R/W
154 to 157	9A _H to 9D _H	System area	—	—
158	9E _H	Mode switching setting	0	R/W
159	9F _H			
160 to 171	A0 _H to AB _H	System area	—	—
172	AC _H	CH1 Difference conversion trigger	0	R/W
173	AD _H	CH2 Difference conversion trigger	0	R/W
174	AE _H	CH3 Difference conversion trigger	0	R/W
175	AF _H	CH4 Difference conversion trigger	0	R/W
176 to 179	B0 _H to B3 _H	System area	—	—
180	B4 _H	CH1 Difference conversion reference value	0	R
181	B5 _H	CH2 Difference conversion reference value	0	R
182	B6 _H	CH3 Difference conversion reference value	0	R
183	B7 _H	CH4 Difference conversion reference value	0	R

Address (decimal)	Address (hexadecimal)	Name	Default *1	Read/Write *2
184 to 189	B8 _H to BD _H	System area	—	—
190	BE _H	CH1 Difference conversion status flag	0	R
191	BF _H	CH2 Difference conversion status flag	0	R
192	C0 _H	CH3 Difference conversion status flag	0	R
193	C1 _H	CH4 Difference conversion status flag	0	R
194 to 199	C2 _H to C7 _H	System area	—	—
200	C8 _H	Pass data classification setting	0	R/W
201	C9 _H	System area	—	—
202	CA _H	CH1 Industrial shipment settings offset value (L)	0	R/W
203	CB _H	CH1 Industrial shipment settings offset value (H)	0	R/W
204	CC _H	CH1 Industrial shipment settings gain value (L)	0	R/W
205	CD _H	CH1 Industrial shipment settings gain value (H)	0	R/W
206	CE _H	CH2 Industrial shipment settings offset value (L)	0	R/W
207	CF _H	CH2 Industrial shipment settings offset value (H)	0	R/W
208	D0 _H	CH2 Industrial shipment settings gain value (L)	0	R/W
209	D1 _H	CH2 Industrial shipment settings gain value (H)	0	R/W
210	D2 _H	CH3 Industrial shipment settings offset value (L)	0	R/W
211	D3 _H	CH3 Industrial shipment settings offset value (H)	0	R/W
212	D4 _H	CH3 Industrial shipment settings gain value (L)	0	R/W
213	D5 _H	CH3 Industrial shipment settings gain value (H)	0	R/W
214	D6 _H	CH4 Industrial shipment settings offset value (L)	0	R/W
215	D7 _H	CH4 Industrial shipment settings offset value (H)	0	R/W
216	D8 _H	CH4 Industrial shipment settings gain value (L)	0	R/W
217	D9 _H	CH4 Industrial shipment settings gain value (H)	0	R/W
218	DA _H	CH1 User range settings offset value (L)	0	R/W
219	DB _H	CH1 User range settings offset value (H)	0	R/W
220	DC _H	CH1 User range settings gain value (L)	0	R/W
221	DD _H	CH1 User range settings gain value (H)	0	R/W
222	DE _H	CH2 User range settings offset value (L)	0	R/W
223	DF _H	CH2 User range settings offset value (H)	0	R/W
224	E0 _H	CH2 User range settings gain value (L)	0	R/W
225	E1 _H	CH2 User range settings gain value (H)	0	R/W
226	E2 _H	CH3 User range settings offset value (L)	0	R/W
227	E3 _H	CH3 User range settings offset value (H)	0	R/W
228	E4 _H	CH3 User range settings gain value (L)	0	R/W
229	E5 _H	CH3 User range settings gain value (H)	0	R/W
230	E6 _H	CH4 User range settings offset value (L)	0	R/W
231	E7 _H	CH4 User range settings offset value (H)	0	R/W

Address (decimal)	Address (hexadecimal)	Name	Default *1	Read/Write *2
232	E8 _H	CH4 User range settings gain value (L)	0	R/W
233	E9 _H	CH4 User range settings gain value (H)	0	R/W
234 to 999	EA _H to 3E7 _H	System area	—	—
1000	3E8 _H	CH1 Logging enable/disable setting	1	R/W
1001	3E9 _H	CH2 Logging enable/disable setting	1	R/W
1002	3EA _H	CH3 Logging enable/disable setting	1	R/W
1003	3EB _H	CH4 Logging enable/disable setting	1	R/W
1004 to 1007	3EC _H to 3EF _H	System area	—	—
1008	3F0 _H	CH1 Logging hold request	0	R/W
1009	3F1 _H	CH2 Logging hold request	0	R/W
1010	3F2 _H	CH3 Logging hold request	0	R/W
1011	3F3 _H	CH4 Logging hold request	0	R/W
1012 to 1015	3F4 _H to 3F7 _H	System area	—	—
1016	3F8 _H	CH1 Logging hold flag	0	R
1017	3F9 _H	CH2 Logging hold flag	0	R
1018	3FA _H	CH3 Logging hold flag	0	R
1019	3FB _H	CH4 Logging hold flag	0	R
1020 to 1023	3FC _H to 3FF _H	System area	—	—
1024	400 _H	CH1 Logging data setting	1	R/W
1025	401 _H	CH2 Logging data setting	1	R/W
1026	402 _H	CH3 Logging data setting	1	R/W
1027	403 _H	CH4 Logging data setting	1	R/W
1028 to 1031	404 _H to 407 _H	System area	—	—
1032	408 _H	CH1 Logging cycle setting value	4	R/W
1033	409 _H	CH2 Logging cycle setting value	4	R/W
1034	40A _H	CH3 Logging cycle setting value	4	R/W
1035	40B _H	CH4 Logging cycle setting value	4	R/W
1036 to 1039	40C _H to 40F _H	System area	—	—
1040	410 _H	CH1 Logging cycle unit setting	1	R/W
1041	411 _H	CH2 Logging cycle unit setting	1	R/W

Address (decimal)	Address (hexadecimal)	Name	Default *1	Read/Write *2
1042	412 _H	CH3 Logging cycle unit setting	1	R/W
1043	413 _H	CH4 Logging cycle unit setting	1	R/W
1044 to 1047	414 _H to 417 _H	System area	—	—
1048	418 _H	CH1 Logging points after trigger	5000	R/W
1049	419 _H	CH2 Logging points after trigger	5000	R/W
1050	41A _H	CH3 Logging points after trigger	5000	R/W
1051	41B _H	CH4 Logging points after trigger	5000	R/W
1052 to 1055	41C _H to 41F _H	System area	—	—
1056	420 _H	CH1 Level trigger condition setting	0	R/W
1057	421 _H	CH2 Level trigger condition setting	0	R/W
1058	422 _H	CH3 Level trigger condition setting	0	R/W
1059	423 _H	CH4 Level trigger condition setting	0	R/W
1060 to 1063	424 _H to 427 _H	System area	—	—
1064	428 _H	CH1 Trigger data	54	R/W
1065	429 _H	CH2 Trigger data	55	R/W
1066	42A _H	CH3 Trigger data	56	R/W
1067	42B _H	CH4 Trigger data	57	R/W
1068 to 1071	42C _H to 42F _H	System area	—	—
1072	430 _H	Level data 0	0	R/W
1073	431 _H	Level data 1	0	R/W
1074	432 _H	Level data 2	0	R/W
1075	433 _H	Level data 3	0	R/W
1076	434 _H	Level data 4	0	R/W
1077	435 _H	Level data 5	0	R/W
1078	436 _H	Level data 6	0	R/W
1079	437 _H	Level data 7	0	R/W
1080	438 _H	Level data 8	0	R/W
1081	439 _H	Level data 9	0	R/W
1082	43A _H	CH1 Trigger setting value	0	R/W
1083	43B _H	CH2 Trigger setting value	0	R/W
1084	43C _H	CH3 Trigger setting value	0	R/W
1085	43D _H	CH4 Trigger setting value	0	R/W

Address (decimal)	Address (hexadecimal)	Name	Default *1	Read/Write *2	
1086 to 1089	43E _H to 441 _H	System area	—	—	
1090	442 _H	CH1 Head pointer	0	R	
1091	443 _H	CH2 Head pointer	0	R	
1092	444 _H	CH3 Head pointer	0	R	
1093	445 _H	CH4 Head pointer	0	R	
1094 to 1097	446 _H to 449 _H	System area	—	—	
1098	44A _H	CH1 Latest pointer	0	R	
1099	44B _H	CH2 Latest pointer	0	R	
1100	44C _H	CH3 Latest pointer	0	R	
1101	44D _H	CH4 Latest pointer	0	R	
1102 to 1105	44E _H to 451 _H	System area	—	—	
1106	452 _H	CH1 Number of logging data	0	R	
1107	453 _H	CH2 Number of logging data	0	R	
1108	454 _H	CH3 Number of logging data	0	R	
1109	455 _H	CH4 Number of logging data	0	R	
1110 to 1113	456 _H to 459 _H	System area	—	—	
1114	45A _H	CH1 Trigger pointer	0	R	
1115	45B _H	CH2 Trigger pointer	0	R	
1116	45C _H	CH3 Trigger pointer	0	R	
1117	45D _H	CH4 Trigger pointer	0	R	
1118 to 1121	45E _H to 461 _H	System area	—	—	
1122	462 _H	CH1 Logging cycle monitor value	(s)	0	R
1123	463 _H		(ms)	0	R
1124	464 _H		(μs)	0	R
1125	465 _H	CH2 Logging cycle monitor value	(s)	0	R
1126	466 _H		(ms)	0	R
1127	467 _H		(μs)	0	R
1128	468 _H	CH3 Logging cycle monitor value	(s)	0	R
1129	469 _H		(ms)	0	R
1130	46A _H		(μs)	0	R

Address (decimal)	Address (hexadecimal)	Name		Default *1	Read/Write *2	
1131	46B _H	CH4 Logging cycle monitor value	(s)	0	R	
1132	46C _H		(ms)	0	R	
1133	46D _H		(μs)	0	R	
1134 to 1153	46E _H to 481 _H	System area		—	—	
1154	482 _H	CH1 Trigger detection time	First two digits of the year	Last two digits of the year	0	R
1155	483 _H		Month	Day	0	R
1156	484 _H		Hour	Minute	0	R
1157	485 _H		Second	Day of the week	0	R
1158	486 _H	CH2 Trigger detection time	First two digits of the year	Last two digits of the year	0	R
1159	487 _H		Month	Day	0	R
1160	488 _H		Hour	Minute	0	R
1161	489 _H		Second	Day of the week	0	R
1162	48A _H	CH3 Trigger detection time	First two digits of the year	Last two digits of the year	0	R
1163	48B _H		Month	Day	0	R
1164	48C _H		Hour	Minute	0	R
1165	48D _H		Second	Day of the week	0	R
1166	48E _H	CH4 Trigger detection time	First two digits of the year	Last two digits of the year	0	R
1167	48F _H		Month	Day	0	R
1168	490 _H		Hour	Minute	0	R
1169	491 _H		Second	Day of the week	0	R
1170 to 1299	492 _H to 513 _H	System area		—	—	
1300	514 _H	CH1 Flow amount integration enable/disable setting		1	R/W	
1301	515 _H	CH2 Flow amount integration enable/disable setting		1	R/W	
1302	516 _H	CH3 Flow amount integration enable/disable setting		1	R/W	
1303	517 _H	CH4 Flow amount integration enable/disable setting		1	R/W	
1304 to 1307	518 _H to 51B _H	System area		—	—	
1308	51C _H	CH1 Integration cycle setting		4	R/W	
1309	51D _H	CH2 Integration cycle setting		4	R/W	

Address (decimal)	Address (hexadecimal)	Name	Default *1	Read/Write *2
1310	51E _H	CH3 Integration cycle setting	4	R/W
1311	51F _H	CH4 Integration cycle setting	4	R/W
1312 to 1315	520 _H to 523 _H	System area	—	—
1316	524 _H	CH1 Flow amount time unit setting	0	R/W
1317	525 _H	CH2 Flow amount time unit setting	0	R/W
1318	526 _H	CH3 Flow amount time unit setting	0	R/W
1319	527 _H	CH4 Flow amount time unit setting	0	R/W
1320 to 1323	528 _H to 52B _H	System area	—	—
1324	52C _H	CH1 Unit scaling setting	0	R/W
1325	52D _H	CH2 Unit scaling setting	0	R/W
1326	52E _H	CH3 Unit scaling setting	0	R/W
1327	52F _H	CH4 Unit scaling setting	0	R/W
1328 to 1331	530 _H to 533 _H	System area	—	—
1332	534 _H	CH1 Integrated flow amount (L)	0	R
1333	535 _H	CH1 Integrated flow amount (H)	0	R
1334	536 _H	CH2 Integrated flow amount (L)	0	R
1335	537 _H	CH2 Integrated flow amount (H)	0	R
1336	538 _H	CH3 Integrated flow amount (L)	0	R
1337	539 _H	CH3 Integrated flow amount (H)	0	R
1338	53A _H	CH4 Integrated flow amount (L)	0	R
1339	53B _H	CH4 Integrated flow amount (H)	0	R
1340 to 1347	53C _H to 543 _H	System area	—	—
1348	544 _H	CH1 Integration cycle monitor value	0	R
1349	545 _H	CH2 Integration cycle monitor value	0	R
1350	546 _H	CH3 Integration cycle monitor value	0	R
1351	547 _H	CH4 Integration cycle monitor value	0	R
1352 to 1355	548 _H to 54B _H	System area	—	—
1356	54C _H	CH1 Flow amount integration temporary stop request	0	R/W
1357	54D _H	CH2 Flow amount integration temporary stop request	0	R/W
1358	54E _H	CH3 Flow amount integration temporary stop request	0	R/W
1359	54F _H	CH4 Flow amount integration temporary stop request	0	R/W

Address (decimal)	Address (hexadecimal)	Name	Default *1	Read/Write *2
1360 to 1363	550 _H to 553 _H	System area	—	—
1364	554 _H	CH1 Flow amount integration temporary stop flag	0	R
1365	555 _H	CH2 Flow amount integration temporary stop flag	0	R
1366	556 _H	CH3 Flow amount integration temporary stop flag	0	R
1367	557 _H	CH4 Flow amount integration temporary stop flag	0	R
1368 to 1371	558 _H to 55B _H	System area	—	—
1372	55C _H	CH1 Integrated flow amount clear request	0	R/W
1373	55D _H	CH2 Integrated flow amount clear request	0	R/W
1374	55E _H	CH3 Integrated flow amount clear request	0	R/W
1375	55F _H	CH4 Integrated flow amount clear request	0	R/W
1376 to 1379	560 _H to 563 _H	System area	—	—
1380	564 _H	CH1 Integrated flow amount clear flag	0	R
1381	565 _H	CH2 Integrated flow amount clear flag	0	R
1382	566 _H	CH3 Integrated flow amount clear flag	0	R
1383	567 _H	CH4 Integrated flow amount clear flag	0	R
1384 to 1799	568 _H to 707 _H	System area	—	—

*1 The default value is a value set after power-on or after resetting the CPU module.

*2 This shows whether read or write from programs is possible.

R: Readable

W: Writable

(2) Error history (Un\G1800 to Un\G4999)

Address (decimal)	Address (hexadecimal)	Name		Default *1	Read/Write *2		
1800	708 _H	Latest address of error history		0	R		
1801 to 1809	709 _H to 711 _H	System area		—	—		
1810	712 _H	No.1	Error code	0	R		
1811	713 _H		Error time	First two digits of the year	0	R	
1812	714 _H			Month	Day	0	R
1813	715 _H			Hour	Minute	0	R
1814	716 _H			Second	Day of the week	0	R
1815 to 1819	717 _H to 71B _H		System area		—	—	
1820 to 1829	71C _H to 725 _H	No.2	Same as No. 1				
1830 to 1839	726 _H to 72F _H	No.3	Same as No. 1				
1840 to 1849	730 _H to 739 _H	No.4	Same as No. 1				
1850 to 1859	73A _H to 743 _H	No.5	Same as No. 1				
1860 to 1869	744 _H to 74D _H	No.6	Same as No. 1				
1870 to 1879	74E _H to 757 _H	No.7	Same as No. 1				
1880 to 1889	758 _H to 761 _H	No.8	Same as No. 1				
1890 to 1899	762 _H to 76B _H	No.9	Same as No. 1				

Address (decimal)	Address (hexadecimal)	Name		Default *1	Read/Write *2
1900 to 1909	76C _H to 775 _H	No.10	Same as No. 1		
1910 to 1919	776 _H to 77F _H	No.11	Same as No. 1		
1920 to 1929	780 _H to 789 _H	No.12	Same as No. 1		
1930 to 1939	78A _H to 793 _H	No.13	Same as No. 1		
1940 to 1949	794 _H to 79D _H	No.14	Same as No. 1		
1950 to 1959	79E _H to 7A7 _H	No.15	Same as No. 1		
1960 to 1969	7A8 _H to 7B1 _H	No.16	Same as No. 1		
1970 to 4999	7B2 _H to 1387 _H	System area		—	—

*1 The default value is a value set after power-on or after resetting the CPU module.

*2 This shows whether read or write from programs is possible.

R: Readable

W: Writable

(3) Logging section (Un\G5000 to Un\G49999)

Address (decimal)	Address (hexadecimal)	Name		Default *1	Read/Write *2
5000 to 14999	1388 _H to 3A97 _H	CH1 Logging data		0	R
15000 to 24999	3A98 _H to 61A7 _H	CH2 Logging data		0	R
25000 to 34999	61A8 _H to 88B7 _H	CH3 Logging data		0	R
35000 to 44999	88B8 _H to AFC7 _H	CH4 Logging data		0	R

Address (decimal)	Address (hexadecimal)	Name	Default *1	Read/Write *2
45000 to 49999	AFC8 _H to C34F _H	System area	—	—

*1 The default value is a value set after power-on or after resetting the CPU module.

*2 This shows whether read or write from programs is possible.

R: Readable

W: Writable

CHAPTER 4 PROCEDURES BEFORE STARTING THE OPERATION

This chapter describes the procedures before starting the operation.

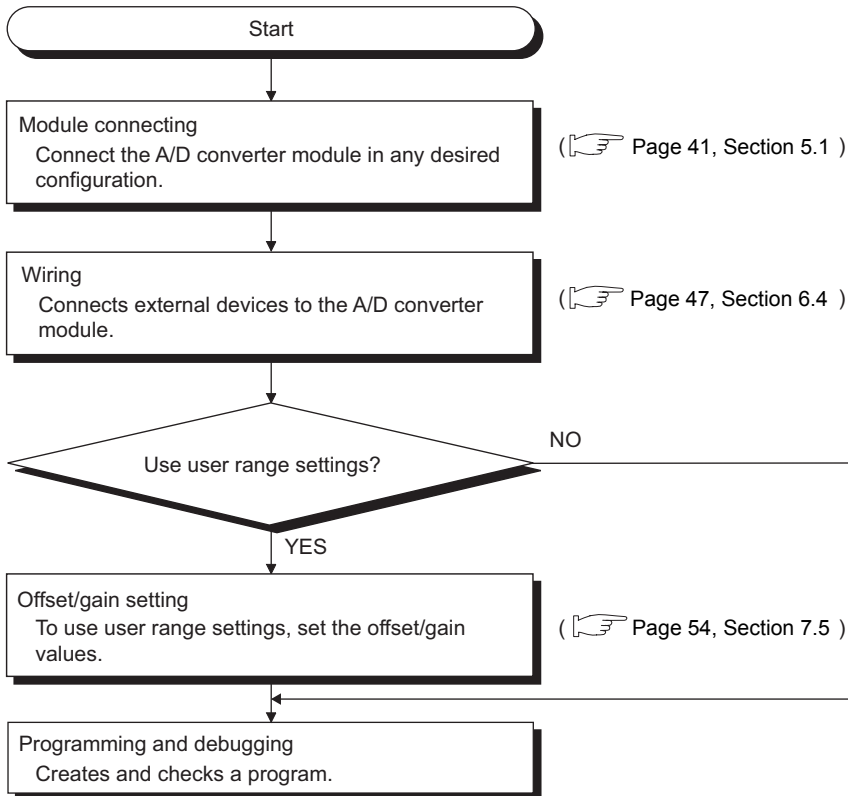

Memo

CHAPTER 5 SYSTEM CONFIGURATION

This chapter describes the overall configuration, number of connectable modules, and compatible software version of the A/D converter module.

5.1 Overall System Configuration

The following shows a system configuration example for using the A/D converter module.

(1) When connected to a CPU module

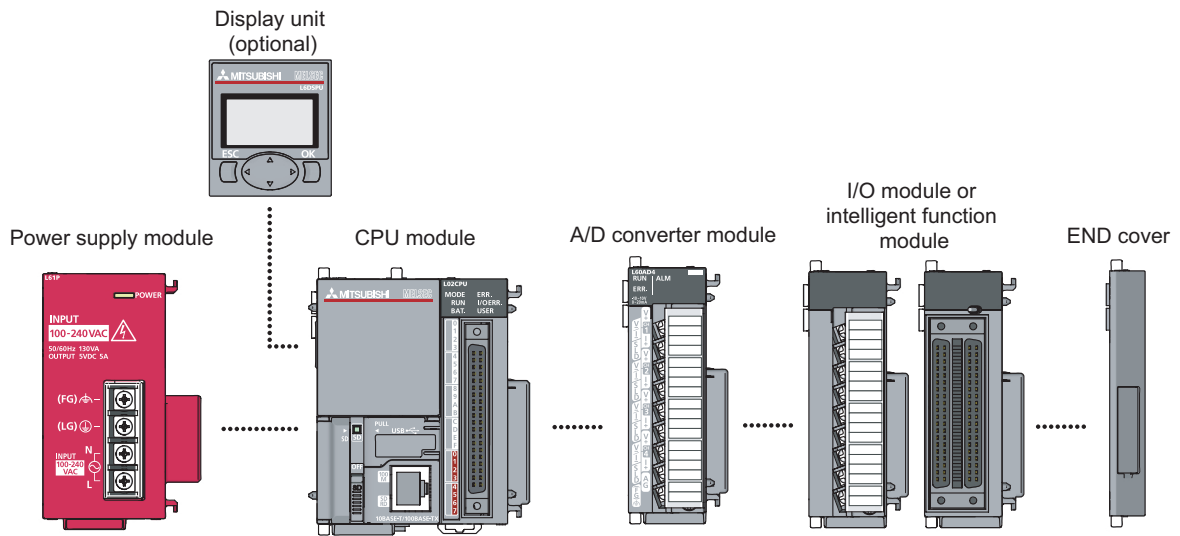

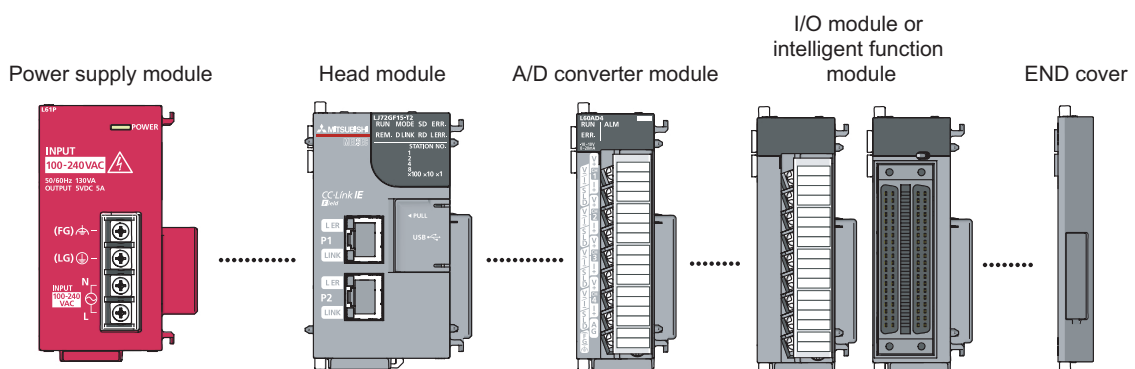

(2) When connected to a head module



5.2 Applicable System



(1) Number of connectable modules

For the number of connectable modules, refer to the following.

-  MELSEC-L CPU Module User's Manual (Hardware Design, Maintenance and Inspection)
-  MELSEC-L CC-Link IE Field Network Head Module User's Manual

(2) Compatible software version

For the compatible software versions, refer to the following.

-  MELSEC-L CPU Module User's Manual (Hardware Design, Maintenance and Inspection)
-  MELSEC-L CC-Link IE Field Network Head Module User's Manual

5.3 Restrictions When A/D Converter Module is Connected to Head Module

The following describes the restriction when the A/D converter module is connected to a head module.



- Dedicated instruction cannot be used.

CHAPTER 6 INSTALLATION AND WIRING

This chapter describes the installation and wiring of the A/D converter module.

6.1 Installation Environment and Installation Position

For precautions for installation environment and installation position, refer to the following.

-  MELSEC-L CPU Module User's Manual (Hardware Design, Maintenance and Inspection)
-  MELSEC-L CC-Link IE Field Network Head Module User's Manual

6.2 Terminal Block

(1) Precautions

Tighten the terminal block screws within the following specified torque range.

Screw type	Tightening torque range
Terminal screw (M3 screw)	0.42 to 0.58N · m
Terminal block mounting screw (M3.5 screw)	0.66 to 0.89N · m

The table below shows applicable solderless terminals connected to the terminal block. When wiring, use applicable wires and an appropriate tightening torque. Use UL-approved solderless terminals and, for processing, use a tool recommended by their manufacturer. Also, sleeved solderless terminals cannot be used.

Solderless terminal		Wire			
Model	Tightening torque	Diameter	Type	Material	Temperature rating
R1.25-3	0.42 to 0.58N · m	AWG 22 to AWG 18	Stranded	Copper	75°C or more

(2) Signal names of the terminal block

The following shows signal names of the terminal block.

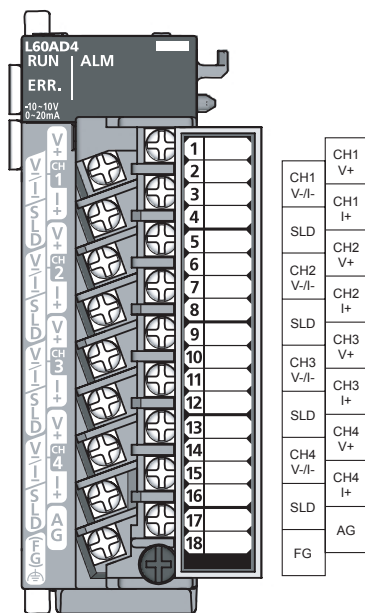

Pin number	Signal name
1	V+
2	V-/I-
3	I+
4	SLD
5	V+
6	V-/I-
7	I+
8	SLD
9	V+
10	V-/I-
11	I+
12	SLD
13	V+
14	V-/I-
15	I+
16	SLD
17	AG
18	FG

(3) Removal and installation of the terminal block

The following shows how to remove and install the terminal block.

(a) Removal procedure

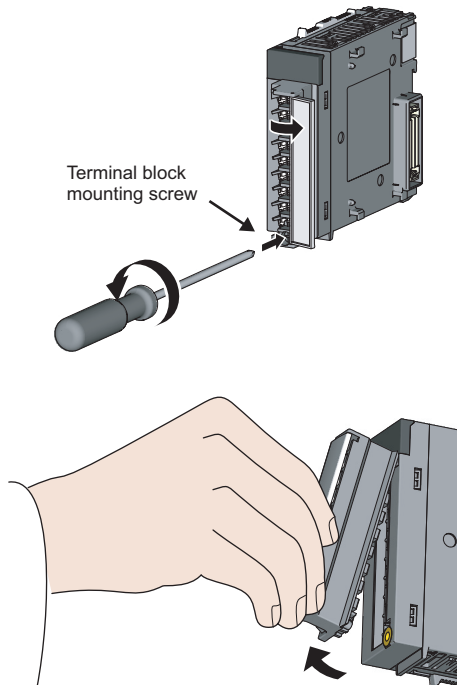

1. Open the terminal cover and loosen the terminal block mounting screw.

2. Using the terminal block fixing holes as a fulcrum, remove the terminal block.

(b) Installation procedure

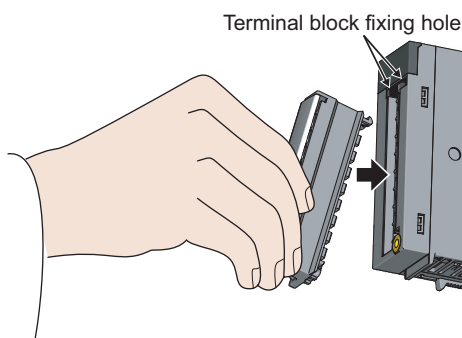

1. Fully insert the projections on the top of the terminal block into the terminal block fixing holes and press the terminal block until it snaps into place.

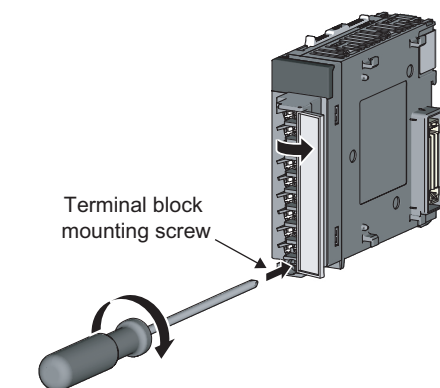

2. Open the terminal cover and tighten the terminal block mounting screw.

6.3 Wiring

(1) Wiring to a terminal block

The following shows wirings to a terminal block.

(a) For the voltage input

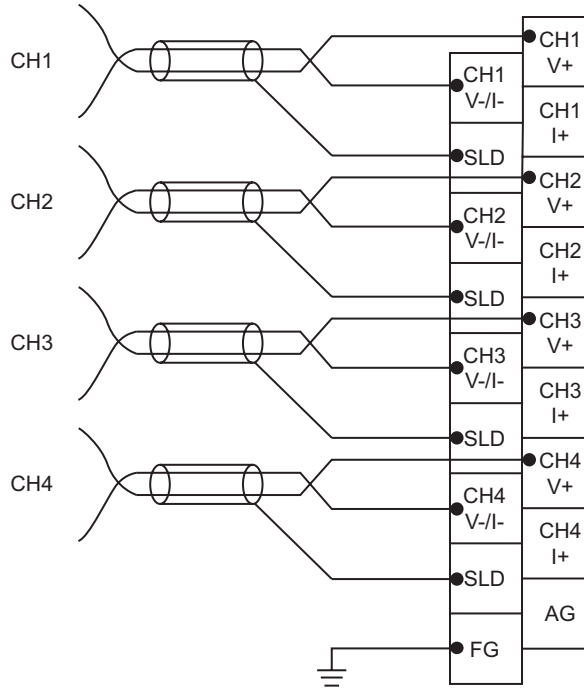

(b) For the current input

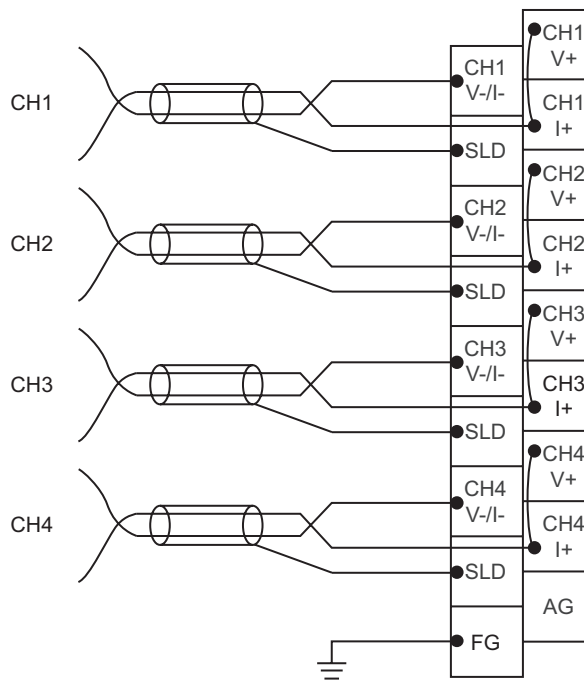

6.4 External Wiring

The following describes the external wiring.

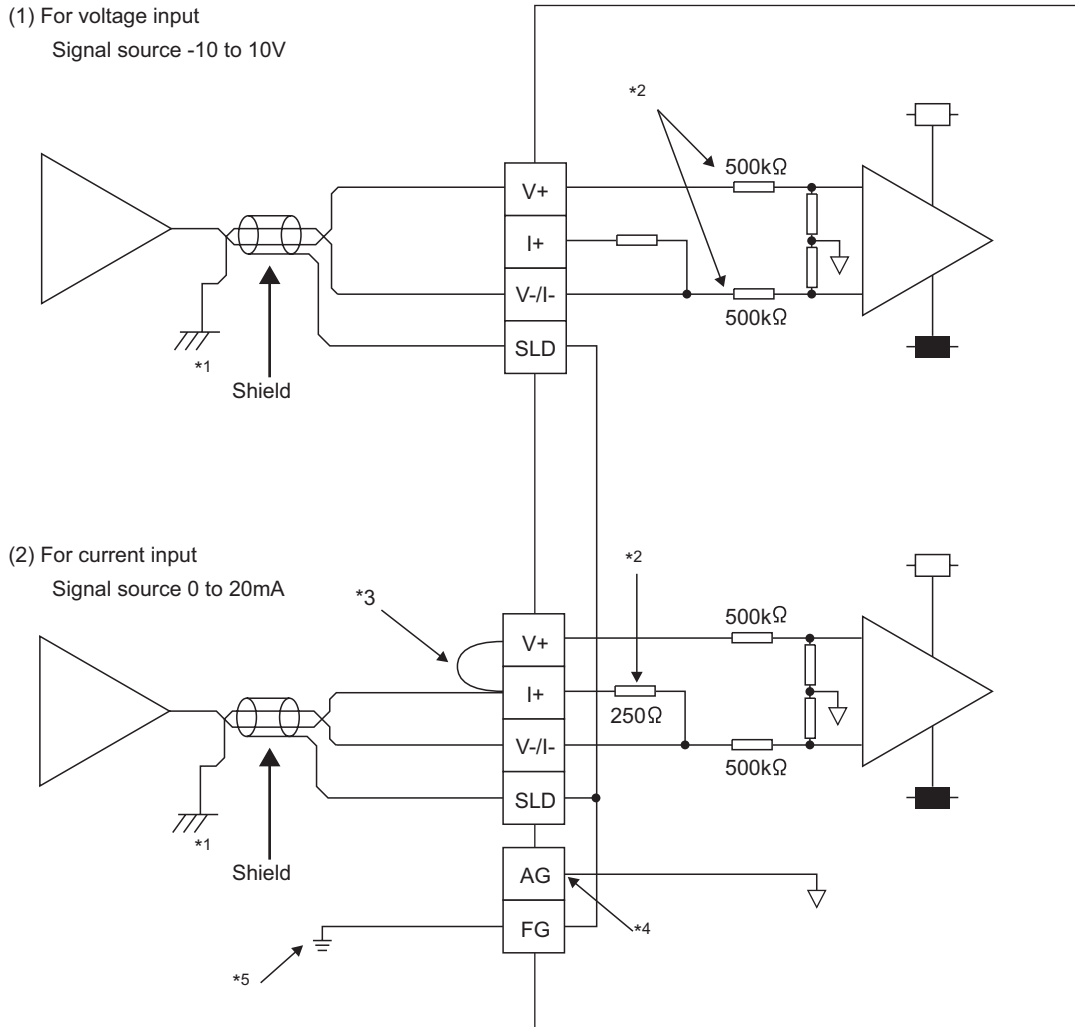

- *1 For the wire, use the shielded twisted pair cable.
- *2 This indicates the input resistance of the A/D converter module.
- *3 For the current input, always connect the terminals (V+) and (I+).
- *4 If there are potential differences between the AG terminal and GND of the external device, connect the AG terminal to the GND of the external device.
- *5 Always connect the shielded wire for each channel to the shield terminal and ground the FG terminal. In addition, ground the FG terminal of the power supply module.

Point

In unused channels, if the circuit between two terminals is kept open, an undefined digital value may be output. To prevent this phenomenon, perform any of the following measures.

- Set the A/D conversion enable/disable setting in the unused channel to disable. Note that changing the A/D conversion enable/disable setting from A/D conversion enable to A/D conversion disable reduces the conversion cycle.
- Short-circuit the input terminal (V+) and (V-) of the unused channel.

CHAPTER 7 VARIOUS SETTINGS

This chapter describes the setting procedures of the A/D converter module.

Point 

After writing the contents of new module, switch settings, parameter settings and auto refresh settings into the CPU module, reset the CPU module, switch STOP → RUN → STOP → RUN, or switch ON the power supply, to validate the setting contents.

7.1 Addition of Modules

Add the model name of A/D converter modules to use on the project.

(1) Addition procedure

Open the "New Module" dialog box.

 Project window ⇨ [Intelligent Function Module] ⇨ Right-click ⇨ [New Module]

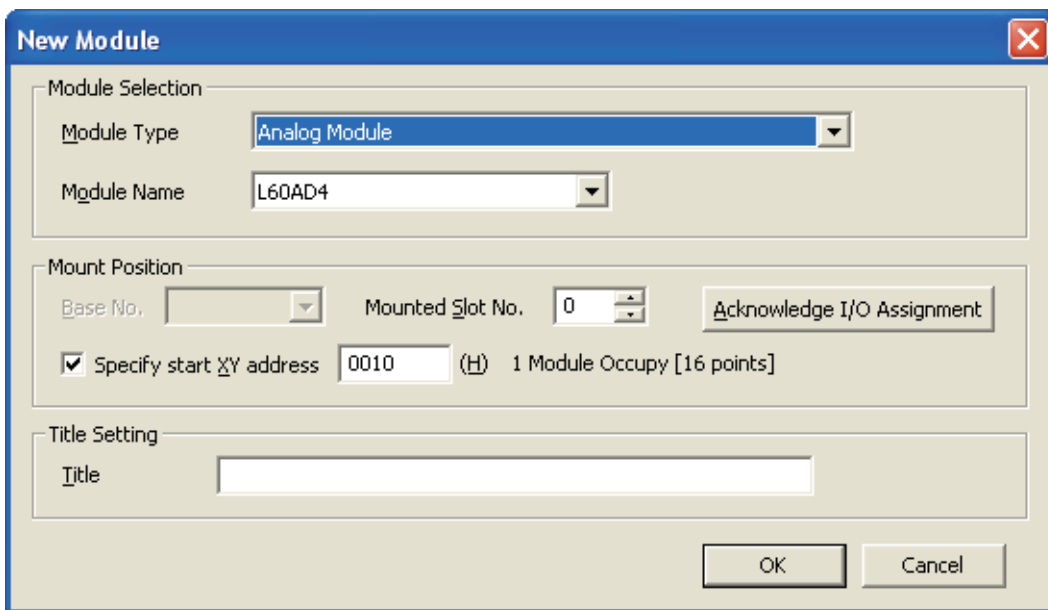

Item		Description
Module Selection	Module Type	Set "Analog Module".
	Module Name	Select the name of the module to connect.
Mount Position	Mounted Slot No.	Set the slot No. where the module is connected.
	Specify start X/Y address	The start I/O number (hexadecimal) of the target module is set, according to the slot No. Setting any start I/O number is also possible.
Title Setting	Title	Set any title.

7.2 Switch Setting

Set the operation mode and the input range used in each CH.

(1) Setting procedure

Open the "Switch Setting" dialog box.

 Project window ⇨ [Intelligent Function Module] ⇨ module name ⇨ [Switch Setting]

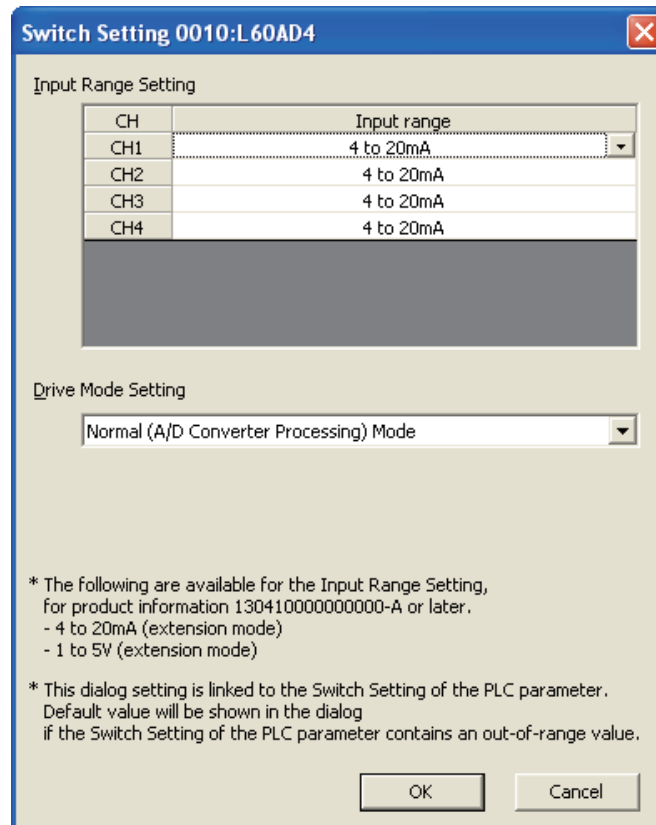

Item	Description	Setting value
Input Range Setting	Set the input range used in each CH.	<ul style="list-style-type: none"> • 4 to 20mA (default value) • 0 to 20mA • 1 to 5V • 0 to 5V • -10 to 10V • 0 to 10V • 4 to 20mA (Extended mode) • 1 to 5V (Extended mode) • User range setting
Drive Mode Setting	Set the operation mode of the A/D converter module.	<ul style="list-style-type: none"> • Normal (A/D conversion processing) mode (default value) • Offset/gain setting mode

7.3 Parameter Setting

Set the parameters of each CH.

By setting the parameters, the setting by programming is unnecessary.

(1) Setting procedure

Open the "Parameter" dialog box.

1. Start "Parameter"

Project window ⇨ [Intelligent Function Module] ⇨ module name ⇨ "Parameter"

Pull-down list type

Text box type

Item	CH1	CH2	CH3	CH4
Basic setting				
A/D conversion enable/disable setting				
Averaging process setting	0:Enable	0:Enable	0:Enable	0:Enable
Time Average/ Count	0:Enable	0:Sampling Processing	0:Sampling Processing	0:Sampling Processing
Average/Moving Average	1:Disable	0	0	0
Conversion speed setting	1:80us			
Warning output function				
Warning output setting				
Process alarm upper upper limit value	0:Enable	1:Disable	1:Disable	1:Disable
Process alarm upper lower limit value	20000	0	0	0
Process alarm lower upper limit value	16000	0	0	0
Process alarm lower lower limit value	10000	0	0	0
Process alarm lower lower limit value	4000	0	0	0
Input signal error detection				
Sets for input signals on A/D conversion.				
Input signal error detection setting	1:Disable	1:Disable	1:Disable	1:Disable
Input signal error detection setting value	5.0 %	5.0 %	5.0 %	5.0 %
Input signal error detection enhancing (Available to Product Information 13041000000000-A or later)				
Input signal error detection extension setting	0:Disable	0:Disable	0:Disable	0:Disable
Scaling function				
Sets for scaling on A/D conversion.				
Scaling enable/disable setting	1:Disable	1:Disable	1:Disable	1:Disable
Scaling upper limit value	0	0	0	0
Scaling lower limit value	0	0	0	0
Shift function (Available to Product Information 13041000000000-A or later)				
Sets whether to permit or prohibit output of A/D conversion value.				

2. Double-click the item to change the setting, and input the setting value.

- Items to input from the pull-down list
Double-click the item to set, to display the pull-down list. Select the item.
- Items to input from the text box
Double-click the item to set, and input the setting value.

3. For setting CH2 to CH4, follow the operation of step2.

Item		Setting value		Reference
Basic setting	A/D conversion enable/disable setting	0: Enable (default value) 1: Disable		Page 63, Section 8.2
	Averaging process setting	0: Sampling Processing (default value) 1: Time Average 2: Count Average 3: Moving Average		Page 63, Section 8.3
	Time Average/ Count Average/ Moving Average	Time Average	20 μ s: 2 to 1500ms (default value: 0) 80 μ s, 1ms: 2 to 5000ms (default value: 0)	
		Count Average	4 to 62500 times (default value: 0)	
		Moving Average	2 to 1000 times (default value: 0)	
Conversion speed setting	0: 20 μ s 1: 80 μ s (default value) 2: 1ms		Page 68, Section 8.5	
Warning output function	Warning output setting	0: Enable 1: Disable (default value)		Page 77, Section 8.9
	Process alarm upper upper limit value	-32768 to 32767 (default value: 0)		
	Process alarm upper lower limit value	-32768 to 32767 (default value: 0)		
	Process alarm lower upper limit value	-32768 to 32767 (default value: 0)		
	Process alarm lower lower limit value	-32768 to 32767 (default value: 0)		
Input signal error detection	Input signal error detection setting	0: Enable 1: Disable (default value)		Page 69, Section 8.7
	Input signal error detection setting value	0 to 25.0% (default value: 5.0%)		
Input signal error detection extension	Input signal error detection extension setting	0: Disable (default value) 1: Upper and Lower Detection 2: Lower Detection 3: Upper Detection 4: Disconnection Detection		Page 74, Section 8.8
Scaling function	Scaling enable/disable setting	0: Enable 1: Disable (default value)		Page 80, Section 8.10
	Scaling upper limit value	-32000 to 32000 (default value: 0)		
	Scaling lower limit value	-32000 to 32000 (default value: 0)		
Shift function	Shifting amount to conversion value	-32768 to 32767 (default value: 0)		Page 86, Section 8.11
Digital clipping function	Digital clipping function enable/disable setting	0: Enable 1: Disable (default value)		Page 90, Section 8.12

	Item	Setting value	Reference
Logging function	Logging enable/disable setting	0: Enable 1: Disable (default value)	Page 98, Section 8.14
	Logging data setting	0: Digital Output Value 1: Scaling Value (Digital Operation Value) (default value)	
	Logging cycle setting value	μs: 80 to 32767 (default value: 4) ms: 1 to 32767 (default value: 4) s: 1 to 3600 (default value: 4)	
	Logging cycle unit setting	0: μs 1: ms (default value) 2: s	
	Logging points after trigger	1 to 10000 (default value: 5000)	
	Level trigger condition setting	0: Disable (default value) 1: Above 2: Below 3: Pass Through	
	Trigger data	0 to 4999 (CH1 default value: 54) (CH2 default value: 55) (CH3 default value: 56) (CH4 default value: 57)	
	Trigger setting value	-32768 to 32767 (default value: 0)	
Flow amount integration function	Flow amount integration enable/disable setting	0: Enabled 1: Disabled (default value)	Page 110, Section 8.15
	Integration cycle setting	1 to 5000ms (default value: 4ms)	
	Flow amount time unit setting	0: /s (default value) 1: /min 2: /h	
	Unit scaling setting	0: × 1 (default value) 1: × 10 2: × 100 3: × 1000 4: × 10000	

7.4 Auto Refresh

This function transfers data in the buffer memory to specified devices.
By the auto refresh setting, reading/writing data by programming is unnecessary.

(1) Setting procedure

Open the "Auto_Refresh" dialog box.

1. Start "Auto_Refresh".

 Project window ⇨ [Intelligent Function Module] ⇨ module name ⇨ [Auto_Refresh]

2. Click the item to setup, and input the auto refresh target device.

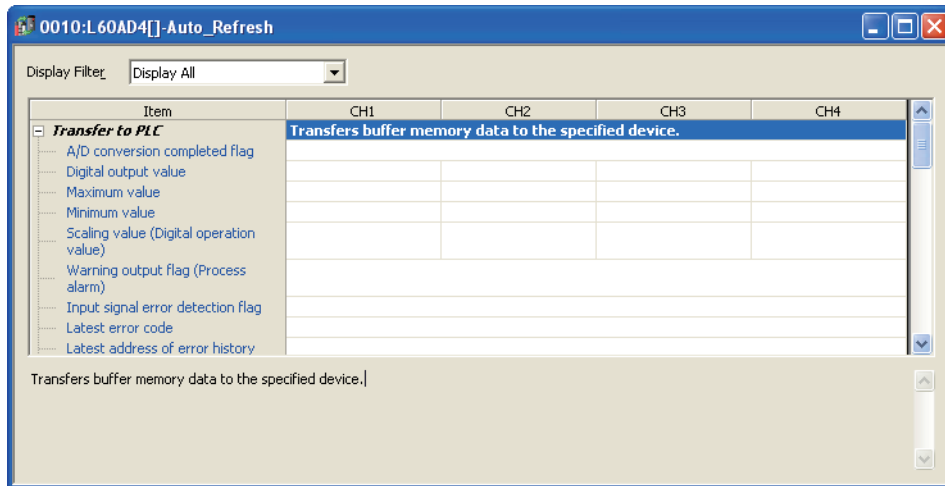

Point

Available devices are X, Y, M, L, B, T, C, ST, D, W, R, and ZR.

When a bit device X, Y, M, L, or B is used, set the number that is divisible by 16 points (example: X10, Y120, M16). Data in the buffer memory are stored in 16 points of devices from the set device No. (Example: When X10 is set, the data are stored in X10 to X1F.)

7.5 Offset/Gain Setting

When using the user range setting, configure the offset/gain setting with the following operations.

When using factory default settings, the offset/gain is not required.

The offset/gain setting can be configured from the following two types of operations.

- Setting from "Offset/Gain Setting" of GX Works2.
- Setting from a program

7.5.1 Setting from GX Works2 "Offset/Gain Setting"

(1) Setting procedure

Open the "Offset/Gain Setting" dialog box.

 [Tool] ⇨ [Intelligent Function Module Tool] ⇨ [Analog Module] ⇨ [Offset/gain Setting...]

1. Select the module to configure the offset/gain setting, and click the  button.

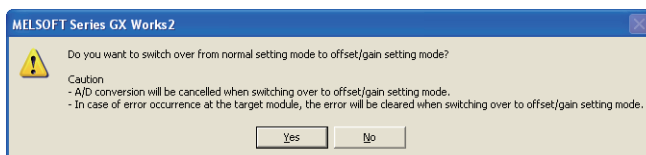
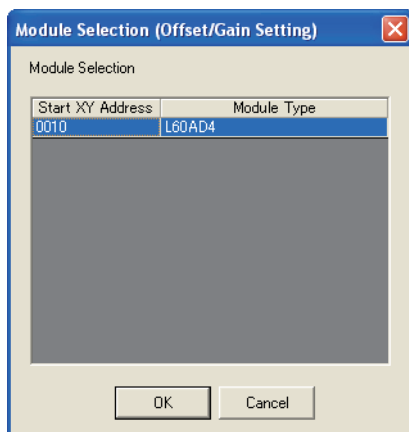

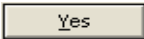
2. Click the  button.

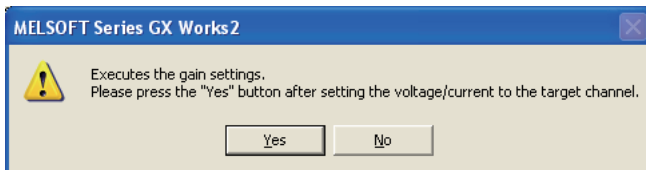
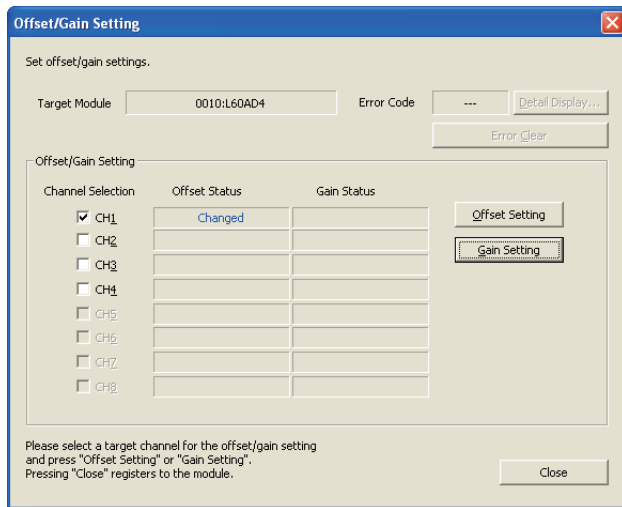
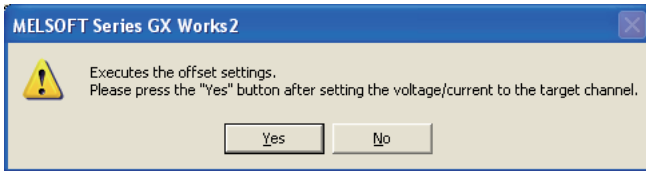
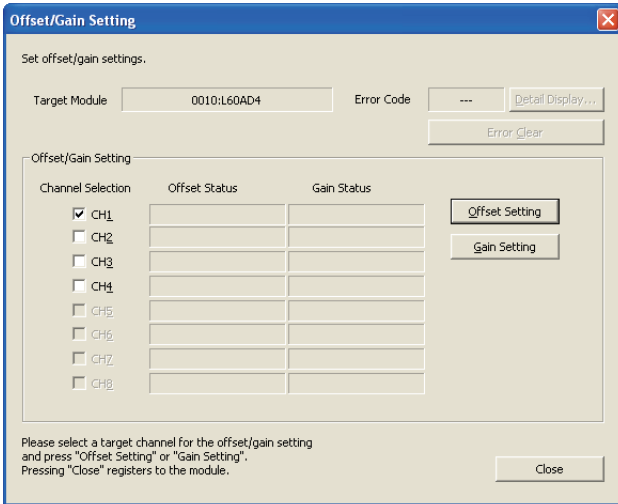

3. Select the channel to use the offset/gain setting, and click the **Offset Setting** button.

4. Input the offset value voltage or current in the target channel terminal, and click the **Yes** button.

5. Check if "Offset Status" is changed to "Changed", and click the **Gain Setting** button.

6. Input the gain value voltage or current in the target channel terminal, and click the **Yes** button.

7. Check if "Gain Status" is changed to "Changed", and click the  button.

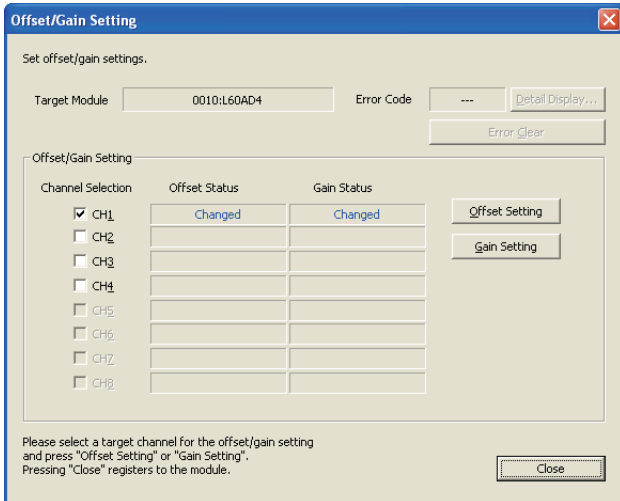

8. Click the  button.

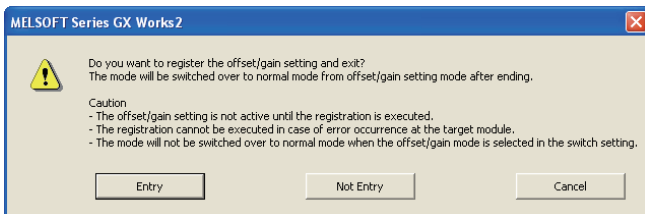

End

7.5.2 Setting from a program

(1) Setting procedure

The following describes the procedures when setting the offset/gain from a program.

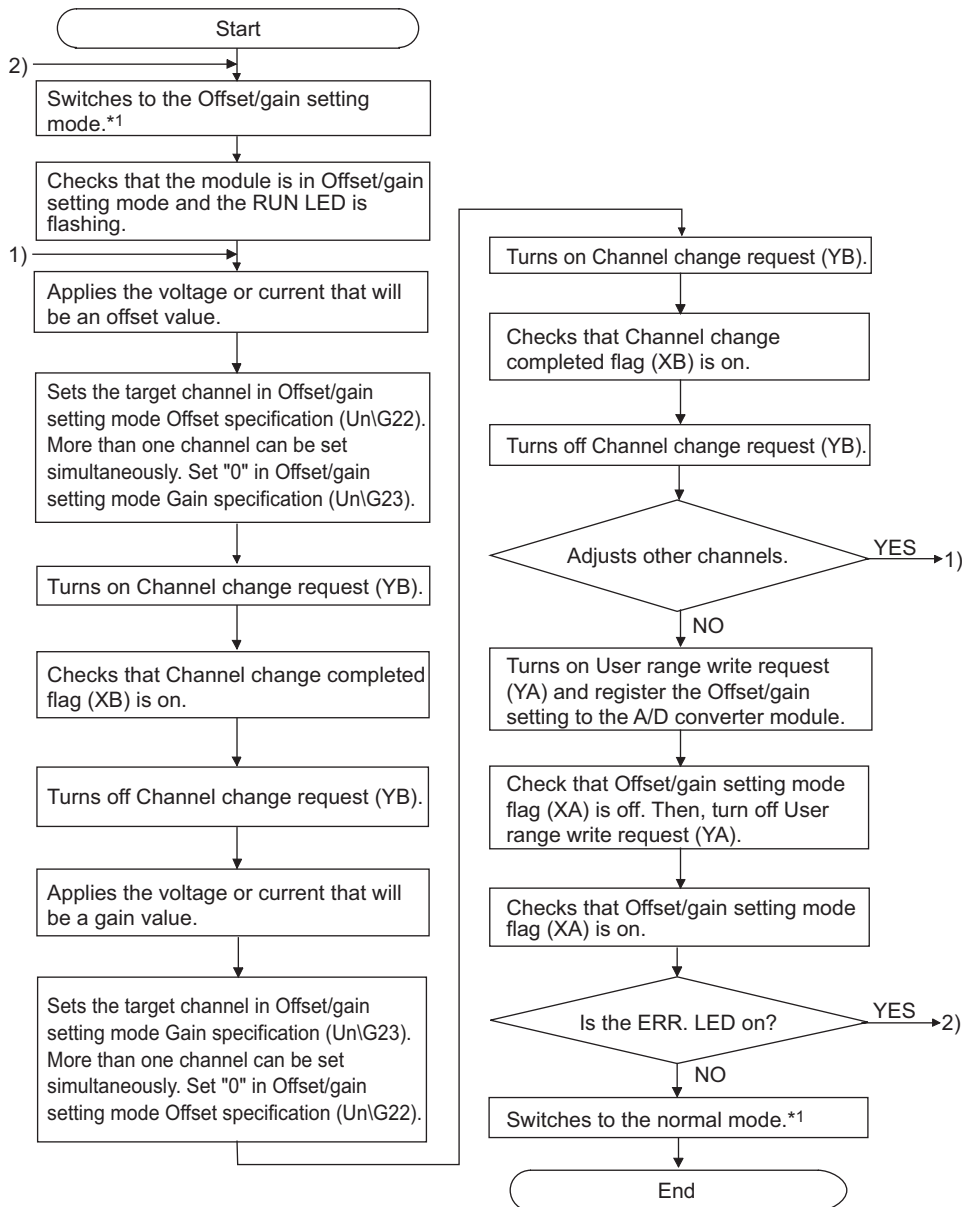

- *1 The following shows the procedure for switching the mode (normal mode → offset/gain setting mode → normal mode).
 Dedicated instruction (G(P).OFFGAN) (☞ Page 210, Appendix 5.2)
 • Setting for Mode switching setting (Un\G158, Un\G159) and OFF → ON → OFF of Operating condition setting request (Y9) (☞ Page 185, Appendix 2(24))
 • Intelligent function module switch setting (☞ Page 49, Section 7.2 (1))

- Configure the offset/gain setting in accordance with the actual use situation.
- Offset and gain values are recorded in the flash memory in the A/D converter module by turning OFF → ON → OFF User range write request (YA). Once recorded, the values are not deleted even after turning the power off. When the values are written 26 times in succession, an error occurs and the error code is stored in Latest error code (Un\G19) to prevent an improper write to flash memory.
- Configure the offset/gain setting in the range satisfying the following condition. When the setting value out of the range is configured, the resolution and accuracy of the module may not fall within the range shown in the following performance specifications.
 - I/O conversion characteristic of A/D conversion (☞ Page 203, Appendix 3)
- Offset/gain setting can be configured for multiple channels at the same time, however, the setting must be configured for offset and gain channels separately. When configuring the setting for offset and gain channels at the same time, an error occurs and ERR. LED turns on.
- When turning ON User range write request (YA), the integrity between the offset values and gain values is checked. When error occurs even in one channel, offset/gain value is not written to the module. Check the value in Latest error code (Un\G19) and perform the following procedures to reconfigure the offset/gain setting from the beginning.
 - Error code list (☞ Page 159, Section 11.4)
- When the mode is switched from the offset/gain setting mode to the normal mode by the setting of the dedicated instruction (G(P).OFFGAN) or Mode switching setting (Un\G158, Un\G159), Module READY (X0) turns from OFF to ON. Note the initial setting process is executed at the switching of the mode if the sequence program executes the initial setting at Module READY (X0) ON.
- To validate the intelligent function module switch setting after writing the setting to the CPU module, reset the CPU module or turn the power supply from OFF to ON.

(2) Program example

(a) Device

Ex. I/O number of the A/D converter module is X/Y30 to 3F (when the L26CPU-BT is used).

The following shows the devices used in the program example.

Device	Functions
M0	Channel selection
M1	Offset setting
M2	Gain setting
M3	Channel change command
M4	Write command to module of offset/gain setting value
M5	Mode switching
D0	Channel-specified storage device
D1	Storage device for the setting value of the dedicated instruction (G(P).OFFGAN)

When using the L02CPU, set the I/O assignments of the A/D converter module to X/Y30 to 3F so that the I/O assignments be the same as that of the system configuration above.

(b) Switching the mode by the dedicated instruction (G(P).OFFGAN)

This program performs the followings:

- first, switches the mode to the offset/gain setting mode by the dedicated instruction (G(P).OFFGAN),
- second, switches the channels for which the offset/gain settings is configured,
- third, writes the offset/gain value to the A/D converter module,
- finally, switches the mode back to the normal modes.

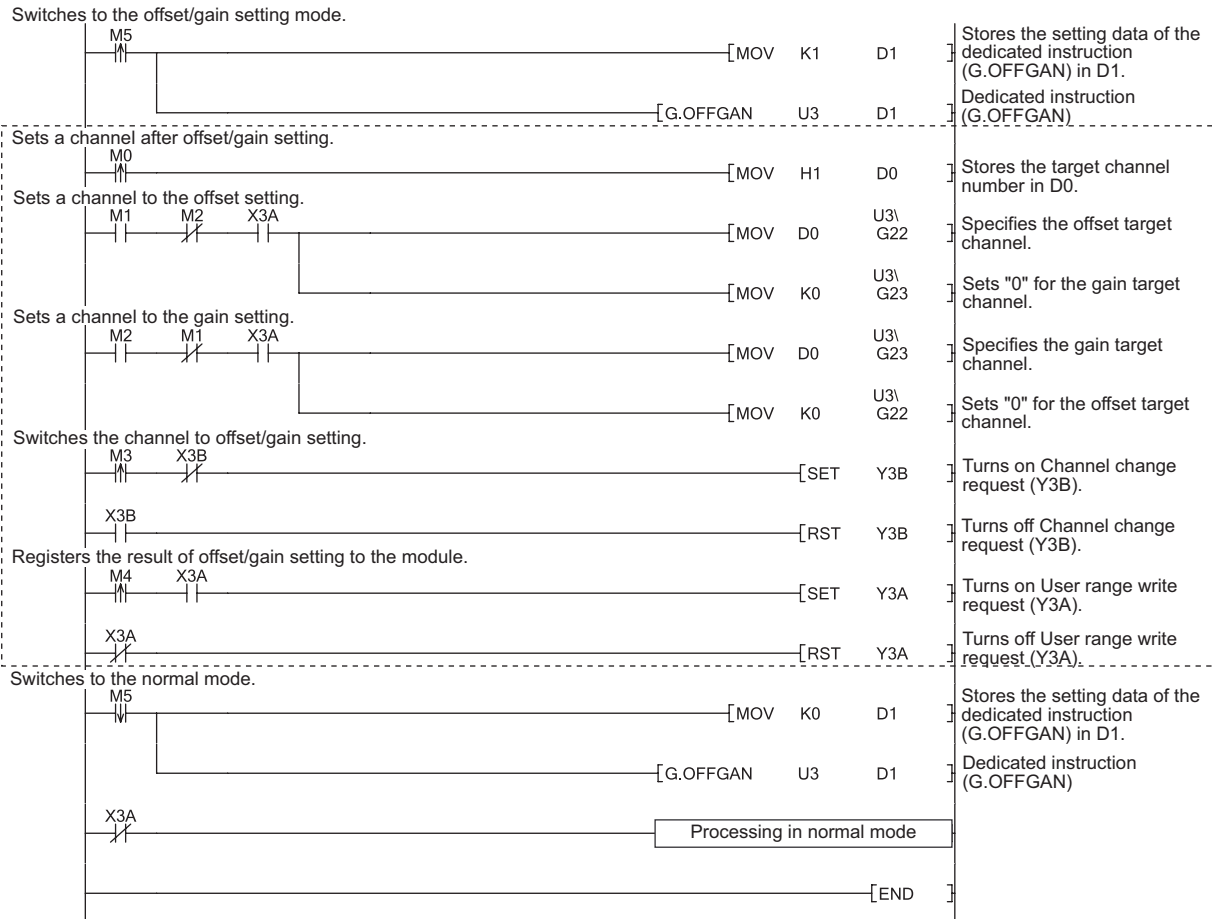
**Point**

The program enclosed by the dotted line is the common programs among the following three programs.

- Switching the mode by the dedicated instruction (G(P).OFFGAN)
- Switching the mode by setting Mode switching setting (Un\G158, Un\G159) and by Operating condition setting request (Y9)
- Switching the mode by the intelligent function module switch setting

(c) Switching the mode by Mode switching setting (Un\G158, Un\G159) and Operating condition setting request (Y9)

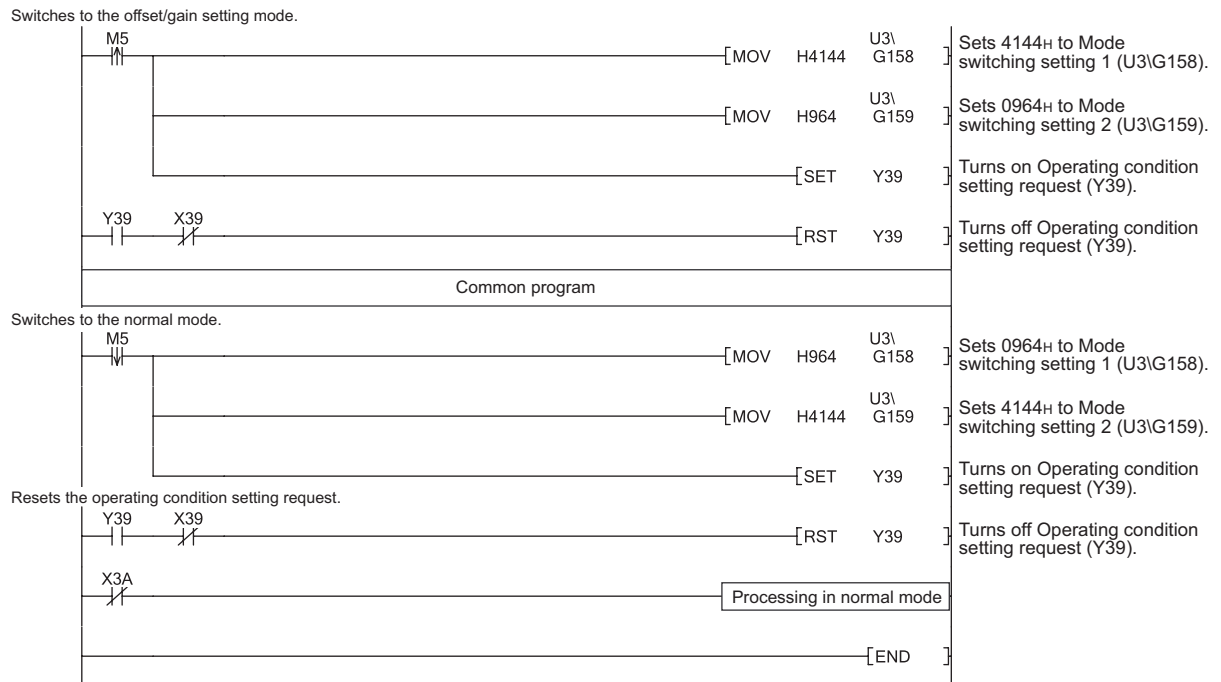

(d) Switching the mode by the intelligent function module switch setting

The programs other than the common program is not necessary.

CHAPTER 8 FUNCTIONS

This chapter describes the details of the functions available in the A/D converter module, and the setting procedures for those functions.

For details on I/O signals and buffer memory, refer to the following.

- Details of I/O signals (☞ Page 167, Appendix 1)
- Details of buffer memory addresses (☞ Page 174, Appendix 2)

8.1 Processing Each Function

The functions are processed in the order shown below. If multiple functions are enabled, the output of the first processed function is used as the input of the next function.

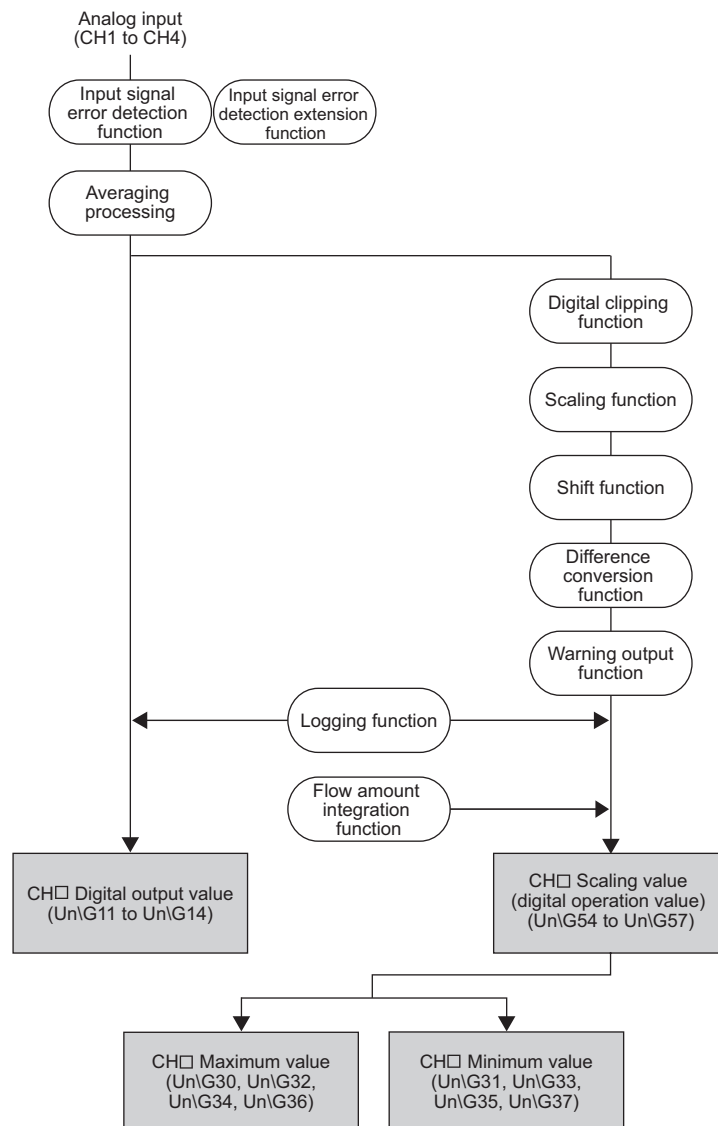

(1) Digital output values

These are digital values after sampling processing or averaging processing has been performed.

(2) Scaling values (digital operation values)

These are values obtained by operating the digital output value using the digital clipping function, scaling function, shift function, or difference conversion function.

(3) Maximum and minimum values

The maximum and minimum values of the scaling values (digital operation values) are stored.

Point

If averaging processing (time average/count average) is performed, the digital values are stored per averaging process cycle.

8.2 A/D Conversion Enable/Disable Function

Sets whether to enable or disable A/D conversion for each channel.

By disabling A/D conversion for the channels you are not using, the conversion cycle can be reduced.

(1) Setting procedure

Set "A/D conversion enable/disable setting" to "0: Enable".

 Project window ⇨ [Intelligent Function Module] ⇨ module name ⇨ [Parameter]

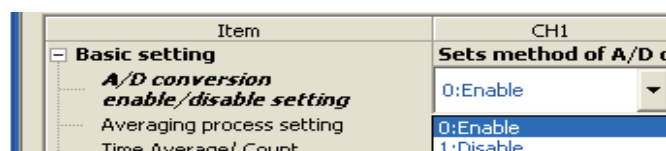

8.3 A/D Conversion Method

Sets whether to perform sampling processing or averaging processing for each channel.

(1) Sampling processing

Sequentially performs A/D conversion on the analog input values and stores the digital output values to the buffer memory.

Point

The conversion cycle is calculated by "Conversion speed × Number of used channels". Conversion can be enabled or disabled per channel, allowing you to reduce the conversion cycle by disabling A/D conversion for the channels that are not used.

Ex. Conversion cycle in the following settings

- Number of used channels (where A/D conversion is enabled): CH1 to CH3 (three channels in total)
- Conversion speed: 80μs (middle speed)

$$80 \times 3 = 240 (\mu\text{s})$$

The conversion cycle is calculated to be 240(μs).

For details on conversion speed setting, refer to the following.

- Conversion Speed Setting ( Page 68, Section 8.5)

(2) Averaging processing

Performs averaging processing on the digital output values for each channel, and stores the average values to the buffer memory.

There are three processes in averaging processing, as follows:

- Time average
- Count average
- Moving average

(a) Time average

Performs A/D conversion for a set time, averages the total without the maximum and minimum values, and stores the average value to the buffer memory.

The processing count within the setting time varies depending on the number of channels used (number of channels for which A/D conversion is enabled).

$$\text{Number of processing times} = \frac{\text{Set period of time}}{(\text{Number of channels used} \times \text{Conversion speed})}$$

Ex. The processing count for the following settings is calculated below:

Item	Setting
Number of channels used (number of channels for which A/D conversion is enabled)	4 channels (CH1 to CH4)
Conversion speed	20 μ s
Set period of time	15 ms

$$\frac{15}{(4 \times 0.02)} = 187.5 \text{ (times)} \cdot \cdot \cdot \text{Drop the fractional part}$$

→ Time is measured 187 times and the averaged value is output.

Point

The valid lower limit setting value for the time average is calculated by "(minimum processing count of 4) \times (conversion speed) \times (number of channels used)".

Ex. If a maximum of 4 channels are used (conversion speed: low speed):

$$4 \times 1.0 \times 4 = 16 \text{ ms}$$

If the processing count becomes less than 4 due to the setting time, an error occurs (error code: 20□), and a digital output value comes out to 0 (zero).

(b) Count average

Performs A/D conversion a set number of times, averages the total without the maximum and minimum values, and stores the average value to the buffer memory.

The time it takes for the count average value to be stored to the buffer memory varies depending on the number of channels used (number of channels for which A/D conversion is enabled).

$$\text{Processing time} = \text{Set number of times} \times (\text{Number of channels used} \times \text{Conversion speed})$$

Ex. The processing time for the following settings is calculated below:

Item	Setting
Number of channels used (number of channels for which A/D conversion is enabled)	4 channels (CH1 to CH4)
Conversion speed	80 μ s
Set number of times	20 times

$$20 \times (4 \times 0.08) = 6.4 \text{ (ms)} \rightarrow \text{An average value is output every 6.4 ms.}$$



Because the count average requires a sum of at least two counts, not counting the maximum and minimum values, the set number of times should be set to 4 or more.

(c) Moving average

Takes the average of digital output values sampled over a set number of sampling cycles, and stores it to the buffer memory.

Since the averaging processing is performed on a moving set of sampling processing, the most current digital output values can be obtained.

The moving average processing for a set number of times of 4 is shown below:

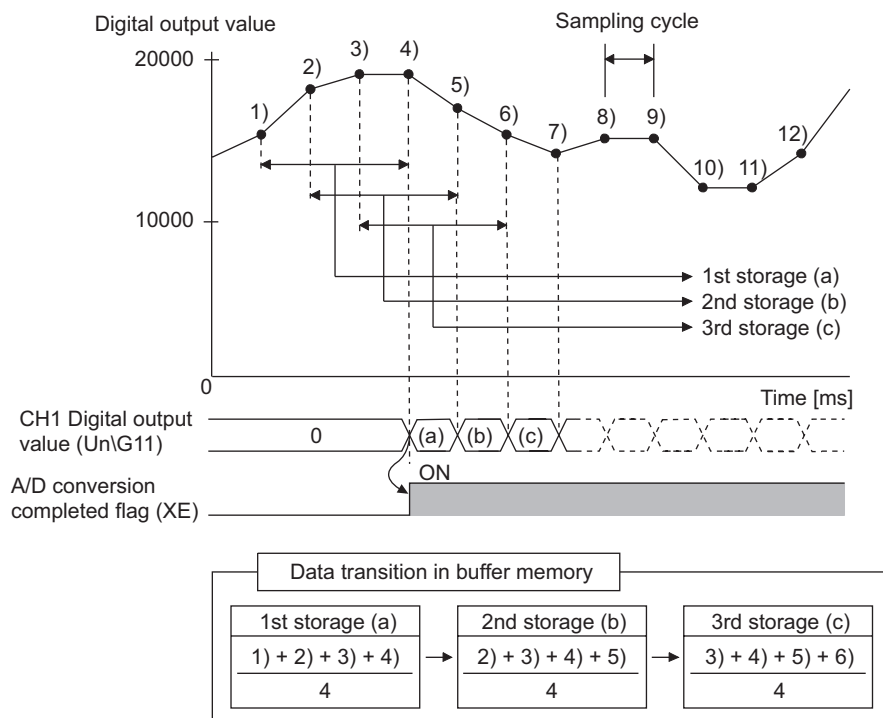

(3) Setting procedure

(a) Sampling processing

1. Set "A/D conversion enable/disable setting" to "0: Enable".

Project window ⇨ [Intelligent Function Module] ⇨ module name ⇨ [Parameter]

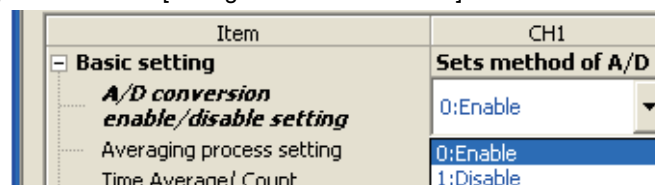

2. For "Averaging process setting", select "0: Sampling Processing".

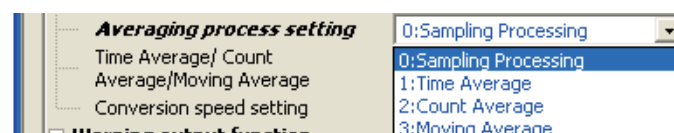

(b) Averaging processing

Ex. To select "1: Time Average" for "Averaging process setting":

1. Set "A/D conversion enable/disable setting" to "0: Enable".

 Project window ⇨ [Intelligent Function Module] ⇨ module name ⇨ [Parameter]

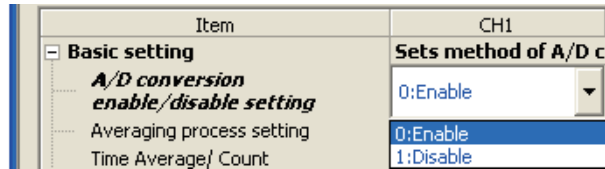

2. For "Averaging process setting", select "1: Time Average".

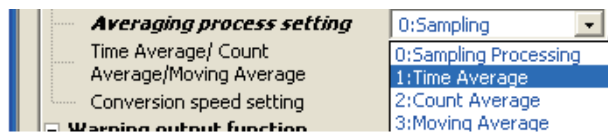

3. For "Time Average/ CountAverage/Moving Average", enter the following:

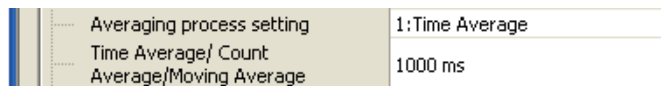

Setting item	Conversion speed	Setting range
Time Average	20 μs	2 to 1500 ms
	80 μs, 1 ms	2 to 5000 ms
Count Average	20 μs, 80 μs, 1 ms	4 to 62500 times
Moving Average	20 μs, 80 μs, 1 ms	2 to 1000 times

Point

The following table shows the conversion cycle of each A/D conversion.

A/D conversion method	Conversion cycle
Sampling processing	Conversion speed × Number of used channels
Time average	$\left(\frac{\text{Time set in "Time Average/Count Average/Moving Average"}}{\text{Conversion speed} \times \text{Number of used channels}} \right)^{*1} \times \text{Conversion speed} \times \text{Number of used channels}$
Count average	Number of times set in "Time Average/Count Average/Moving Average" × Conversion speed × Number of used channels
Moving average	Conversion speed × Number of used channels

*1 The value after the decimal point is rounded off.

8.4 Input Range Extended Mode Function

Using this function, the available input range in 4 to 20mA and 1 to 5V can be extended.

Normal mode			Extended mode		
Input range setting	Input range	Digital output value	Input range setting	Input range	Digital output value
4 to 20mA	4 to 20mA	0 to 20000	4 to 20mA (Extended mode)	0.0 to 22.0mA	-5000 to 22500
1 to 5V	1 to 5V		1 to 5V (Extended mode)	0.0 to 5.5V	

(1) Overview

- The analog input value can be monitored in the extended mode even if errors vary depending on sensors and the analog input value is less than 4mA or 1V in the input range of 4 to 20mA and 1 to 5V.
- The slope of Input/output characteristic of the extended mode is the same as that of the normal mode. However, the upper limit value and the lower limit value of the input range and the digital output value are extended.
- The resolution is the same between the extended input range and the input range of 4 to 20mA and 1 to 5V. This enables the A/D conversion with higher resolution compared to the use of the input range of 0 to 20mA and 0 to 5V.

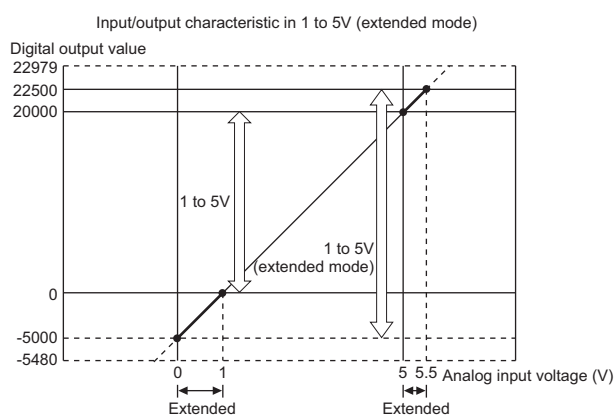
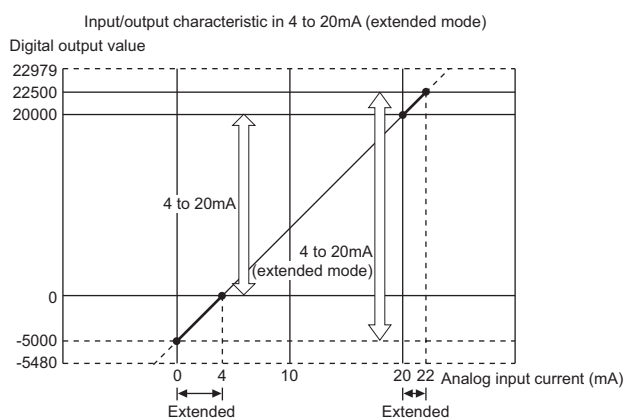

For details on the current input characteristic and voltage input characteristic, refer to the following.

- I/O conversion characteristic of A/D conversion (☞ Page 203, Appendix 3)

(2) Setting procedure

Set the input range into the extended mode in the input range setting of the switch setting.

Point

If the input range extended mode function, scaling function, shift function, and difference conversion function are simultaneously used, the digital output value may exceed the range of -32768 to 32767. In this case, a value fixed at the upper limit value (32767) or at the lower limit value (-32768) is stored as a scaling value (digital operation value).

- Processing each function (☞ Page 61, Section 8.1)

8.5 Conversion Speed Switch Function

You can select from three conversion speeds:

- High speed: 20 μ s/channel
- Medium speed: 80 μ s/channel
- Low speed: 1 ms/channel

(1) Setting procedure

1. Set "A/D conversion enable/disable setting" to "0: Enable".

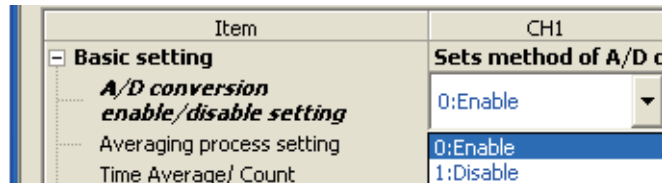

 Project window \Rightarrow [Intelligent Function Module] \Rightarrow module name \Rightarrow [Parameter]

2. For "Conversion speed setting", select the appropriate conversion speed.

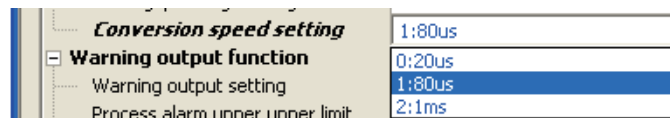

8.6 Maximum and Minimum Values Hold Function

Using this function, the maximum and minimum scaling values (digital operation values) can be stored to the buffer memory for each channel.

If averaging processing is specified, the values are updated per averaging process cycle. Otherwise they are updated per sampling cycle.

For a list of buffer memory addresses to which the values are stored, refer to the following.

- List of Buffer Memory Addresses ( Page 26, Section 3.5)

(1) Resetting maximum and minimum values

Switching Maximum value/minimum value reset request (YD) or Operating condition setting request (Y9) from OFF \rightarrow ON \rightarrow OFF updates the maximum and minimum values with the current values.

(2) Targets of the maximum and minimum values

The maximum and minimum scaling values (digital operation values) are stored to the buffer memory.

For details, refer to the following.

- Processing each function ( Page 61, Section 8.1)

8.7 Input Signal Error Detection Function

Detects any analog input value that is outside the setting range. By using the input signal error detection extension function, the upper limit detection, lower limit detection, or disconnection detection can be set.

For details on the input signal error detection extension function, refer to the following.

Input signal error detection extension function (☞ Page 74, Section 8.8)

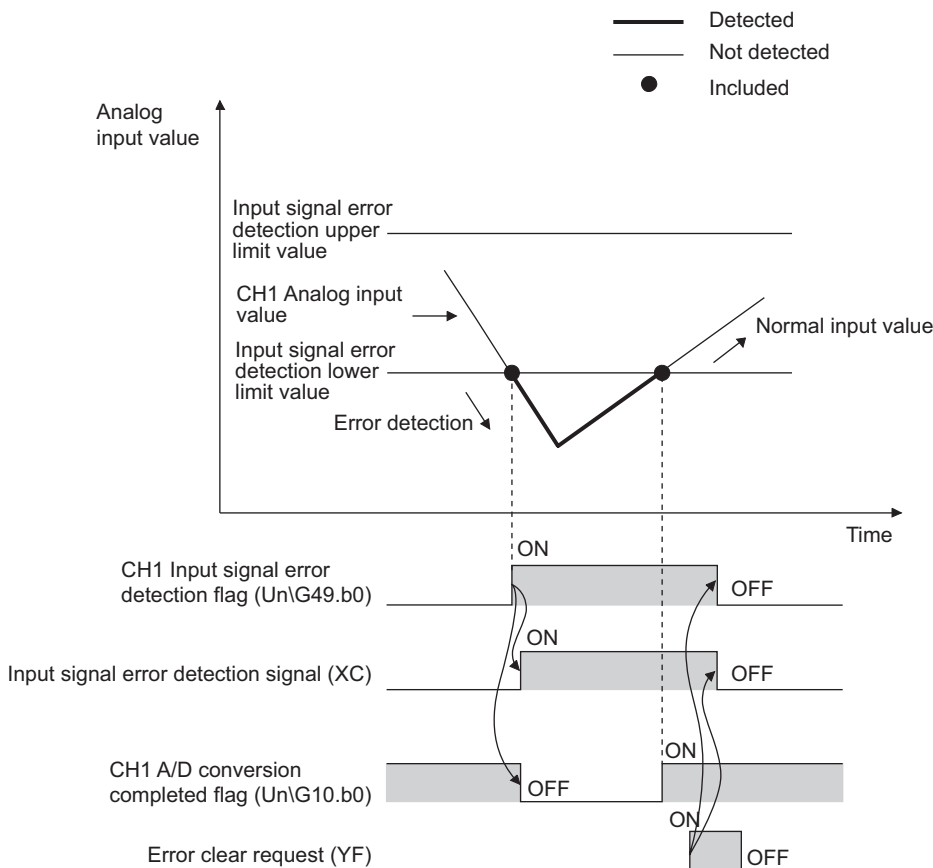

(1) Notification of input signal error

If the analog input value is above the input signal error detection upper limit value, or below the input signal error detection lower limit value, the error is notified by Input signal error detection flag (UnG49), Input signal error detection signal (XC), and the flashing ALM LED.

In addition, alarm code 110□ gets stored in Latest error code (UnG19).

The alarm code that is stored is shown below:

110□
 Fixed ↑ Input signal error channel number

For details on alarm codes, refer to the following.

- Alarm code list (☞ Page 163, Section 11.5)

(2) Operation of the input signal error detection function

The digital output value on the channel on which the error was detected is held at the value just before the error was detected, and A/D conversion completed flag (Un\G10) and A/D conversion completed flag (XE) are turned OFF.

In addition, once the analog input value returns within the setting range, A/D conversion resumes regardless of the reset of Input signal error detection flag (Un\G49) and Input signal error detection signal (XC). After the first update, A/D conversion completed flag (Un\G10) for this channel turns back ON. (ALM LED remains flashing.)

(3) Detection cycle

This function is executed per sampling cycle.

(4) Clearing the input signal error detection

After the analog input value returns within the setting range, turn Error clear request (YF) OFF → ON → OFF.

When the input signal error is cleared, the A/D converter module results in the following state:

- Input signal error detection flag (Un\G49) is cleared.
- Input signal error detection signal (XC) turns OFF.
- The ALM LED turns off.
- The alarm code 110□, which is stored in Latest error code (Un\G19), is cleared.

(5) Setting the input signal error detection upper and lower limit values

Set the input signal error detection upper and lower limit values based on the input signal error detection setting value. (Set the values in increments of 1 (0.1%))

Input signal error detection setting value is reflected in both the input signal error detection upper and lower limit values.

(a) Input signal error detection upper limit value

Add the gain value to "Input range width (gain value – offset value) multiplied by input signal error detection setting value". The input signal error detection setting value is calculated by the following formula:

$$\text{Input signal error detection setting value} = \frac{\text{Input signal error detection upper limit value} - \text{Gain value of each range}}{\text{Gain value of each range} - \text{Offset value of each range}} \times 1000$$

(b) Subtract the gain value from Input signal error detection lower limit value

"Input range width (gain value – offset value) multiplied by input signal error detection setting value". The input signal error detection setting value is calculated by the following formula:

$$\text{Input signal error detection setting value} = \frac{\text{Lower limit value of each range} - \text{Input signal error detection lower limit value}}{\text{Gain value of each range} - \text{Offset value of each range}} \times 1000$$

Remark

The following table lists the lower limit value, offset value, or gain value for each range.

	Analog input range	Lower limit value	Offset value	Gain value
Voltage	0 to 10V	0V		10V
	0 to 5V	0V		5V
	1 to 5V	1V		5V
	-10 to 10V	-10V	0V	10V
	1 to 5V (Extended mode)	1V		5V
	User range setting	Analog input value when the digital output value is -20000	Analog input value set as a offset value by the user	Analog input value set as a gain value by the user
Current	0 to 20mA	0mA		20mA
	4 to 20mA	4mA		20mA
	4 to 20mA (Extended mode)	4mA		20mA
	User range setting	Analog input value when the digital output value is -20000	Analog input value set as a offset value by the user	Analog input value set as a gain value by the user

(6) Example of input signal error detection

Ex. To detect an error when the analog input value becomes lower than 2.4mA for a channel with an input range of 4mA to 20mA:

Substitute the following values into the input signal error detection lower limit value.

- Input signal error detection lower limit value: 2.4mA
- Input range lower limit value (Offset value): 4.0mA
- Gain value: 20.0mA

$$\begin{aligned} \text{Input signal error detection} &= \frac{4.0 - 2.4}{20.0 - 4.0} \times 1000 \\ \text{setting value} &= 100(10.0\%) \end{aligned}$$

Therefore, set the input signal error detection setting value to 100 (10.0%).

In this case, the input signal error detection value behaves as follows. (With the 100 (10%) setting, an error is detected when the value is not only 2.4mA, but also 21.6mA.)

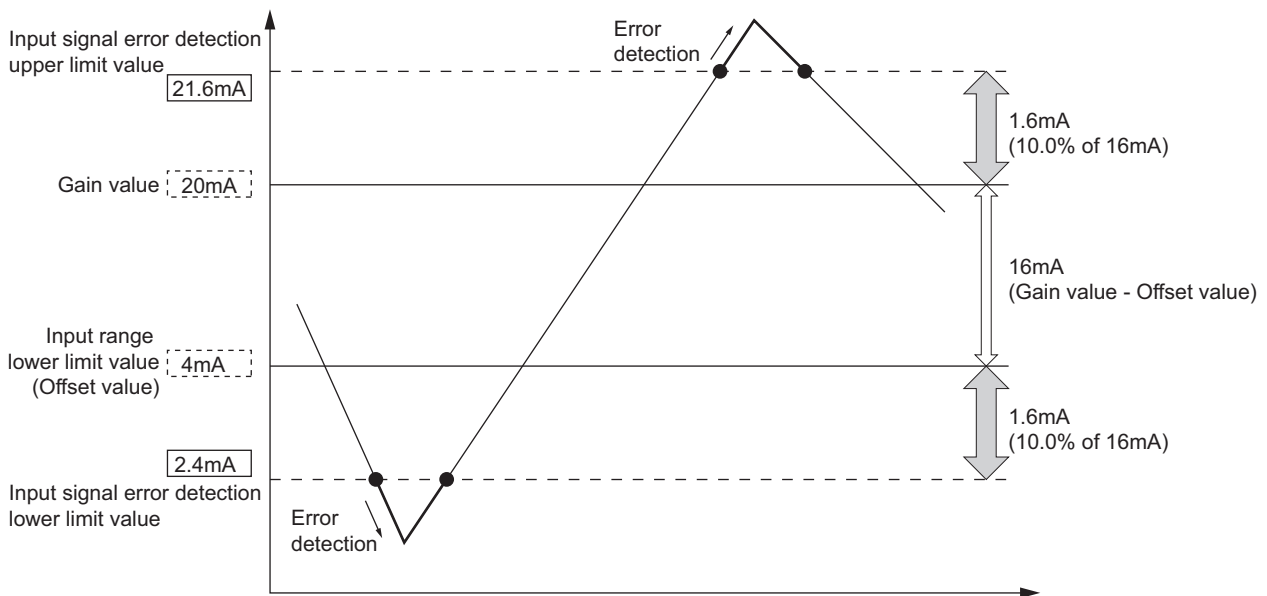

(7) Setting procedure

To enable the input signal error detection function, the input signal error detection extension function should be disabled. When the input signal error detection extension function is enabled, the setting of input signal error detection function is ignored.

1. Set "A/D conversion enable/disable setting" to "0: Enable".

Project window ⇨ [Intelligent Function Module] ⇨ module name ⇨ [Parameter]

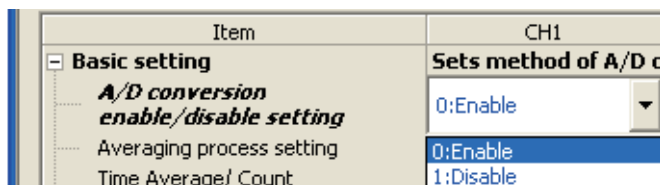

2. Set "Input signal error detection setting" to "0: Enable".



3. Set a value for "Input signal error detection setting value".

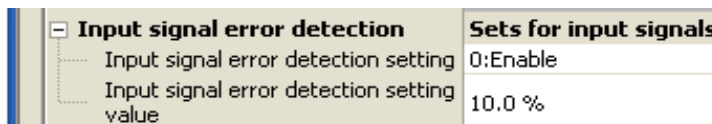

4. Set "Input signal error detection extension setting" to "0: Disable".

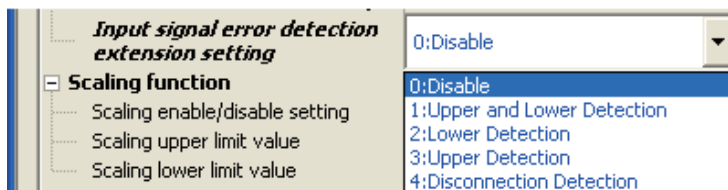

Item	Setting range
Input signal error detection setting value	0 to 25.0%

8.8 Input Signal Error Detection Extension Function

Using this function, the detection method of the input signal error detection function can be extended. Use this function to detect an input signal error only at the lower or upper limit, or to execute the disconnection detection. To enable this function, the input signal error detection function does not need to be enabled.

(1) Detection method

As well as the input signal error detection function, an error can be detected with input signal error detection upper limit value and input signal error detection lower limit value.

For details on the setting procedure of input signal error detection upper limit value and input signal error detection lower limit value, refer to the following.

- Input signal error detection function (☞ Page 69, Section 8.7)

The detection method can be selected from the following list:

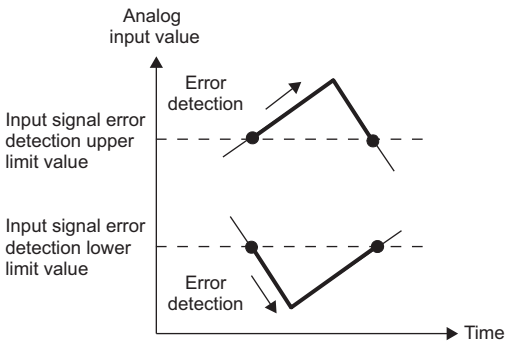
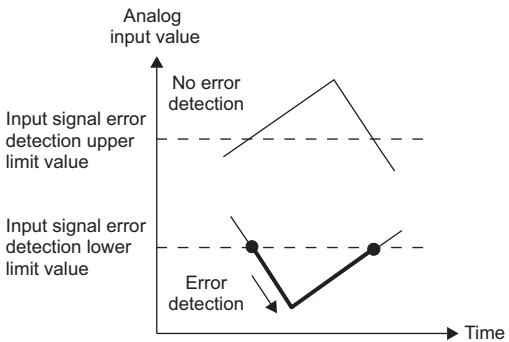
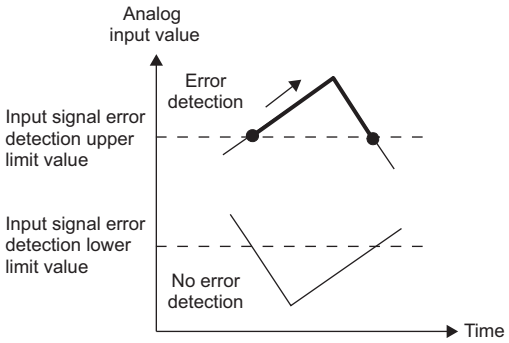
Detection method	Detection condition	
Lower upper limit detection	An error is detected above the input signal error detection upper limit value or below the input signal error detection lower limit value.	 <p>Analog input value</p> <p>Input signal error detection upper limit value</p> <p>Input signal error detection lower limit value</p> <p>Error detection</p> <p>Time</p>
Lower limit detection	An error is detected below the input signal error detection lower limit value.	 <p>Analog input value</p> <p>Input signal error detection upper limit value</p> <p>Input signal error detection lower limit value</p> <p>Error detection</p> <p>Time</p>
Upper limit detection	An error is detected above the input signal error detection upper limit value.	 <p>Analog input value</p> <p>Input signal error detection upper limit value</p> <p>Input signal error detection lower limit value</p> <p>Error detection</p> <p>Time</p>
Disconnection detection	Disconnection detection is performed. For details, refer to the following. <ul style="list-style-type: none"> • Disconnection detection (☞ Page 75, Section 8.8 (1)(a)) 	

(a) Disconnection detection

By combining this detection method with the input range extended mode function, simple disconnection detection can be performed. When either of following conditions is satisfied, Input signal error detection flag (Un\G49) turns on and a disconnection occurs.

Input range	Disconnection detection condition
4 to 20mA (Extended mode)	Input analog value \leq 2mA
1 to 5V (Extended mode)	Input analog value \leq 0.5V

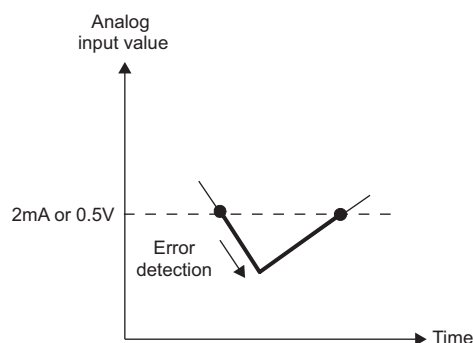

The setting for CH□ Input signal error detection setting value (Un\G142 to Un\G145) is ignored.

(2) Notification of input signal error

If the analog input value satisfies the detection condition of the set detection method, the error is notified by Input signal error detection flag (Un\G49), Input signal error detection signal (XC), and the flashing ALM LED. In addition, alarm code 11△□ gets stored in Latest error code (Un\G19). The value of the alarm code to be stored varies depending on the condition (upper limit, lower limit, or disconnection detection) under which an error of the analog input value is detected.

The following shows the alarm code to be stored.

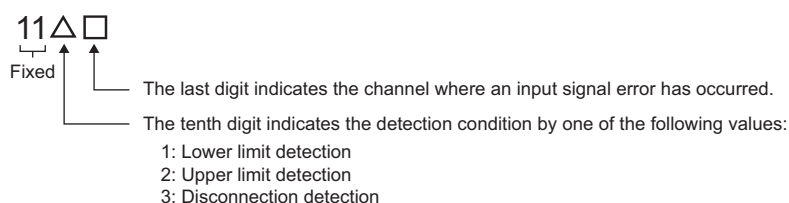

For details on alarm codes, refer to the following.

- Alarm code list (👉 Page 163, Section 11.5)

(3) Operation of the input signal error detection extension function

The operation is the same as that of the input signal error detection function.

For details, refer to the following.

- Input signal error detection function (👉 Page 69, Section 8.7)

(4) Detection cycle

This function is executed per sampling cycle.

(5) Clearing the input signal error detection

As in the input signal error detection function, turn Error clear request (YF) OFF → ON → OFF after the analog input value returns within the setting range. When the disconnection detection is set, after the analog input value exceeds 2.0mA or 0.5V, turn Error clear request (YF) OFF → ON → OFF.

For details, refer to the following.

- Input signal error detection function (☞ Page 69, Section 8.7)

(6) Specifying the input signal error detection upper and lower limit values

As well as the input signal error detection function, set them based on the input signal error detection setting value.

For details, refer to the following.

- Input signal error detection function (☞ Page 69, Section 8.7)

(7) Setting procedure

1. Set "A/D conversion enable/disable setting" to "0: Enable".

☞ Project window ⇒ [Intelligent Function Module] ⇒ module name ⇒ [Parameter]

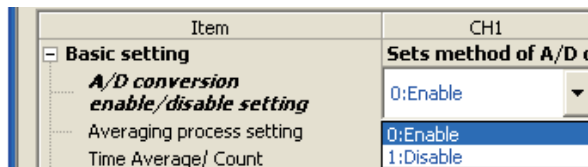

2. Set the detection method in "Input signal error detection extension setting"

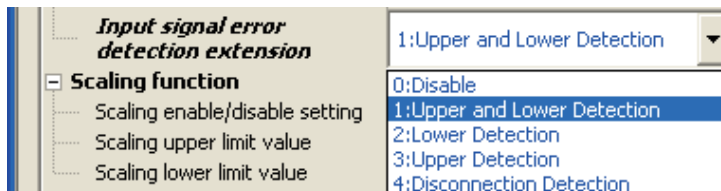

3. Set a value for "Input signal error detection setting value".

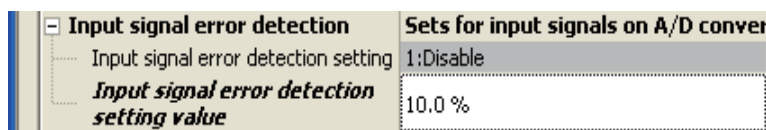

Item	Setting range
Input signal error detection setting value	0 to 25.0%

Point

- If "4: Disconnection Detection" is set to a channel whose input range is not 4 to 20mA (Extended mode) or 1 to 5V (Extended mode), an error occurs.
- The setting in "Input signal error detection setting" is ignored when "Input signal error detection extension setting" is set to other than "0: Disable". An input signal error is detected according to the setting of "Input signal error detection extension setting".

8.9 Warning Output Function (Process Alarm)

Outputs an alarm when the digital output value enters a preset range.

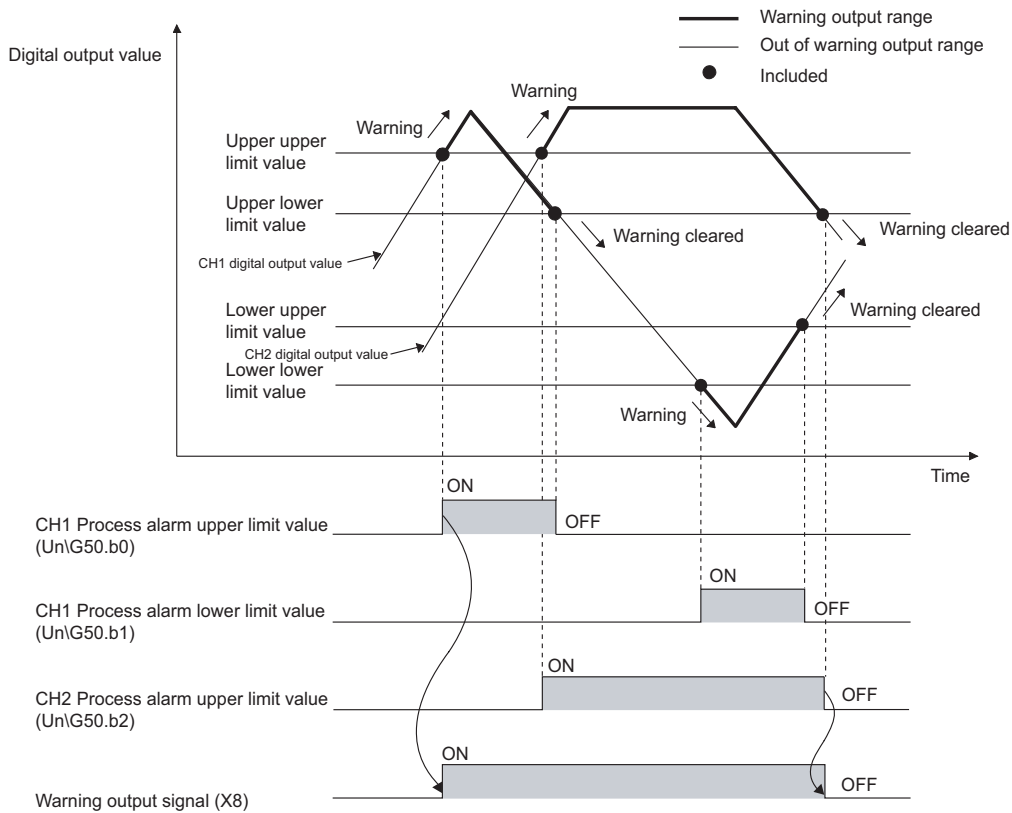

(1) Process alarm notification

When the digital output value moves above the process alarm upper upper limit value, or below the process alarm lower lower limit value, thus entering the alarm output range, alarm notifications are made by Warning output flag (Process alarm) (Un\G50), Warning output signal (X8) and the ALM LED turning ON.

In addition, alarm code 10△□ gets stored in Latest error code (Un\G19).

The alarm code that is stored is shown below:

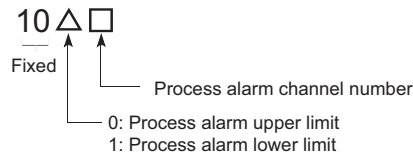

(2) Operation of the Warning output function (Process alarm)

After the alarm is output, once the digital output value returns within the setting range, below the process alarm upper upper limit value and above the process alarm lower upper limit value, a "0" (zero) is stored in the bit position corresponding to the channel number for Warning output flag (Process alarm) (Un\G50).

Once all channels are within the setting range, Warning output signal (X8) and the ALM LED turn OFF.

(3) Detection cycle

When time average is specified, the function is executed per set time (for averaging). When count average is specified, the function is executed per set count (for averaging).

In addition, when sampling processing and moving average are specified, the function is executed per sampling cycle.

(4) Clearing the alarm code

After the digital output value returns within the setting range, turn Error clear request (YF) OFF → ON → OFF.

This clears the alarm code 10△□, which was stored in Latest error code (Un\G19).

(5) Alarm output target

Alarm output target is CH□ Scaling value (digital operation value) (Un\G54 to Un\G57).

For CH1 Process alarm lower lower limit value (Un\86) through CH4 Process alarm upper upper limit value (Un\G101), set values considering digital clipping, scale conversion, shift conversion, and difference conversion.

(6) Setting procedure

1. Set "A/D conversion enable/disable setting" to "0: Enable".

Project window ⇨ [Intelligent Function Module] ⇨ module name ⇨ [Parameter]

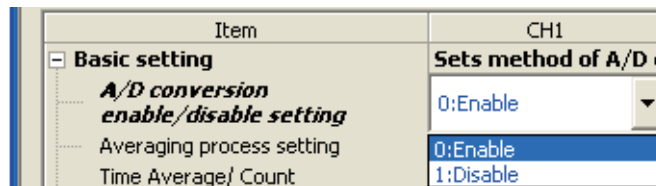

2. Set "Warning output setting" to "0: Enable".

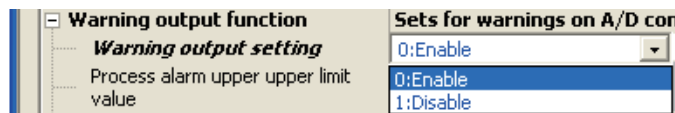

3. Specify the values for "Process alarm upper upper limit value", "Process alarm upper lower limit value", "Process alarm lower upper limit value", and "Process alarm lower lower limit value".

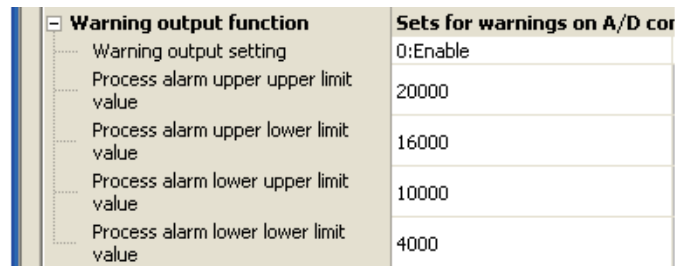

Item	Setting range
Process alarm upper upper limit value	-32768 to 32767
Process alarm upper lower limit value	
Process alarm lower upper limit value	
Process alarm lower lower limit value	

Point 

Process alarm output settings must meet the following condition:

Process alarm upper upper limit value \geq Process alarm upper lower limit value \geq Process alarm lower upper limit value \geq
Process alarm lower lower limit value

8.10 Scaling Function

Performs scale conversion on the digital values that are output. The values are converted in the range between the scaling upper limit value and the scaling lower limit value.

The converted values are stored to CH□ Scaling value (digital operation value) (Un\G54 to Un\G57).

(1) Concept of scaling setting

Ex. If the input range is set to -10 to 10V:

For the scaling lower limit value, set it to a value corresponding to the lower limit of the input range (-20000), and for the scaling upper limit value, set it to a value corresponding to the upper limit of the input range (20000).

(2) Calculation of the scaling value (digital operation value)

For A/D conversion, use the values produced by the following formulas.

(Values after the decimal point are rounded off during scale conversion.)

- When the voltage and current are as follows:

Voltage: 0 to 10V, 0 to 5V, 1 to 5V, 1 to 5V (Extended mode)^{*1}, user range setting

Current: 0 to 20mA, 4 to 20mA, 4 to 20mA (Extended mode)^{*1}, user range setting

$$\text{Scaling value (digital operation value)} = \frac{Dx \times (SH - SL)}{DMax} + SL$$

- When voltage is -10 to 10V

$$\text{Scaling value (digital operation value)} = \frac{Dx \times (SH - SL)}{DMax - DMin} + \frac{(SH + SL)}{2}$$

Item	Description
Dx	Digital output value
DMax	Maximum digital output value of the input range used
DMin	Minimum digital output value of the input range used
SH	Scaling upper limit value
SL	Scaling lower limit value

*1 Although the digital output value range in the extended mode is -5000 to 22500, this function scales digital output values that are within the range of 0 to 20000. For the setting example of scaling using the extended mode, refer to the following.

- Example of scaling setting (👉 Page 82, Section 8.10 (4))

(3) Setting procedure

1. Set "A/D conversion enable/disable setting" to "0: Enable".

 Project window ⇨ [Intelligent Function Module] ⇨ module name ⇨ [Parameter]

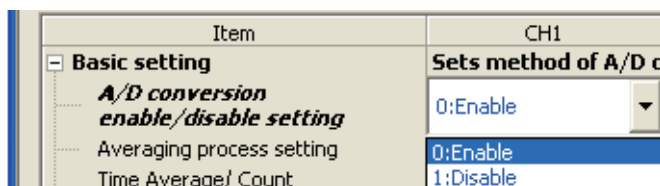

2. Set "Scaling enable/disable setting" to "0: Enable".



3. Set values for "Scaling upper limit value" and "Scaling lower limit value".

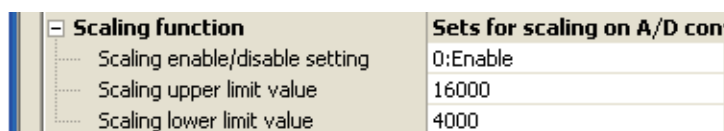

Item	Setting range
Scaling upper limit value	-32000 to 32000
Scaling lower limit value	

Point 

- Even if you set the scaling upper limit value and the scaling lower limit value in such a way that the change is larger than the resolution, the resolution will not increase.
- Your scaling settings must meet the following condition:
Scaling upper limit value > Scaling lower limit value

(4) Example of scaling setting

Ex. 1. When values are set for a channel with input range of 0 to 5V as follows:

- "Scaling upper limit value": 16000
- "Scaling lower limit value": 4000

Scaling function	Sets for scaling on A/D con
Scaling enable/disable setting	0:Enable
Scaling upper limit value	16000
Scaling lower limit value	4000

The digital output values and scaling values (digital operation values) are as follows:

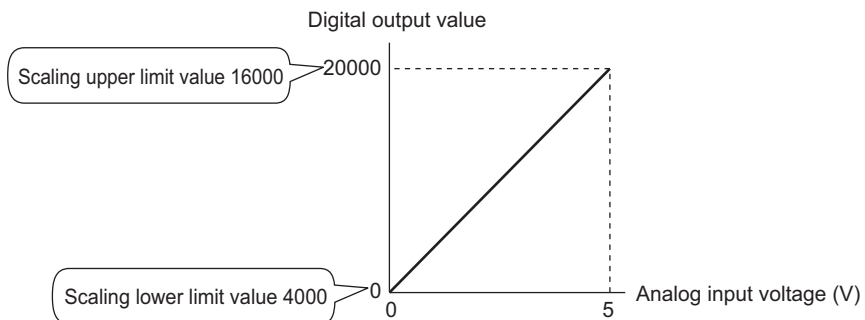

Analog input voltage (V)	Digital output value	Scaling value (digital operation value)
0	0	4000
1	4000	6400
2	8000	8800
3	12000	11200
4	16000	13600
5	20000	16000

Ex. 2. When values are set for a channel with input range of -10 to 10V as follows:

- "Scaling upper limit value": 16000
- "Scaling lower limit value": 4000

Scaling function	Sets for scaling on A/D con
Scaling enable/disable setting	0:Enable
Scaling upper limit value	16000
Scaling lower limit value	4000

The digital output values and scaling values (digital operation values) are as follows:

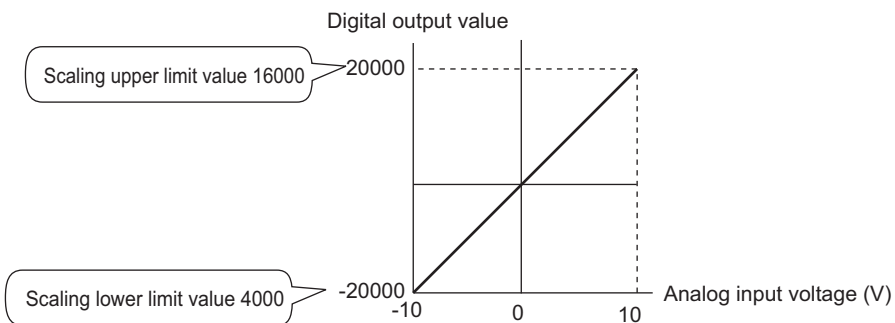

Analog input voltage (V)	Digital output value	Scaling value (digital operation value)
-10	-20000	4000
-5	-10000	7000
0	0	10000
5	10000	13000
10	20000	16000

Ex. 3: When values are set for a channel with input range of 1 to 5V (Extended mode) as follows:

- "Scaling upper limit value": 16000
- "Scaling lower limit value": 4000

Scaling function		Sets for scaling on A/D con:
Scaling enable/disable setting		0:Enable
Scaling upper limit value		16000
Scaling lower limit value		4000

The digital output values and scaling values (digital operation values) are as follows:

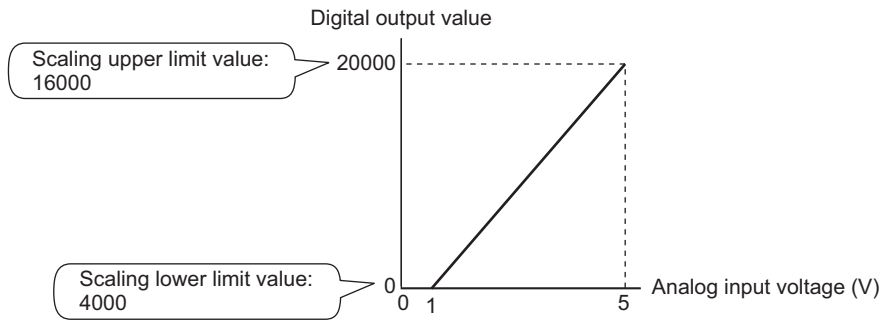

Analog input voltage (V)	Digital output value	Scaling value (digital operation value)
0	-5000	1000
1	0	4000
2	5000	7000
3	10000	10000
4	15000	13000
5	20000	16000
5.5	22500	17500

Ex. 4: When values are set for a channel with user range of 2 to 10V as follows:

- "Scaling upper limit value": 16000
- "Scaling lower limit value": 4000

Scaling function		Sets for scaling on A/D con
Scaling enable/disable setting		0:Enable
Scaling upper limit value		16000
Scaling lower limit value		4000

The digital output values and scaling values (digital operation values) are as follows:

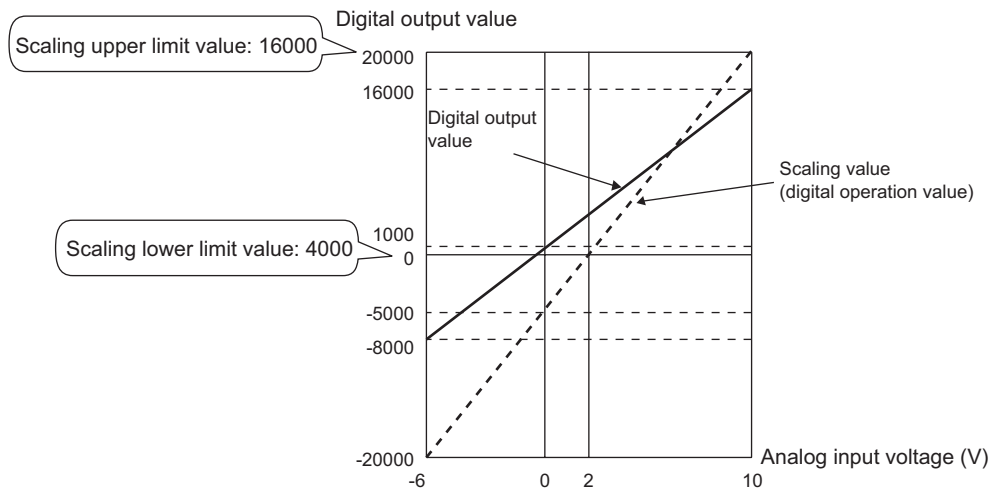

Analog input voltage (V)	Digital output value	Scaling value (digital operation value)
-6	-20000	-8000
-4	-15000	-5000
-2	-10000	-2000
0	-5000	1000
2	0	4000
4	5000	7000
6	10000	10000
8	15000	13000
10	20000	16000

8.11 Shift Function

Using this function, the set shifting amount to conversion value can be added (shifted) to the digital output value and it can be stored in the buffer memory. When the shifting amount to conversion value is changed, it is reflected to the scaling value (digital operation value) in real time. Therefore, fine adjustment can be easily performed when the system starts.

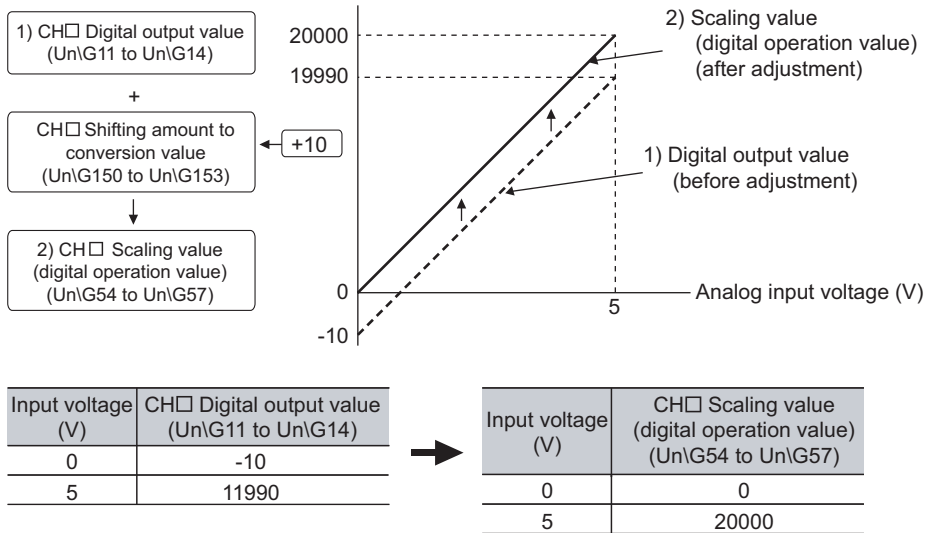

(1) Operation of the shift function

The set shifting amount to conversion value is added to the scaling value (digital operation value). The scaling value (digital operation value) with shift addition is stored in CH Scaling value (digital operation value) (UnG54 to UnG57). The shift amount is added in every sampling cycle for sampling processing, while it is added in every averaging process cycle for averaging processing. Then, those added values are stored in CH Scaling value (digital operation value) (UnG54 to UnG57).

If some value is set to the shifting amount to conversion value, the shifting amount to conversion value is added regardless of the status change (OFF → ON → OFF) of Operating condition setting request (Y9).

(2) Setting procedure

1. Set "A/D conversion enable/disable setting" to "0: Enable".

Project window ⇒ [Intelligent Function Module] ⇒ module name ⇒ [Parameter]

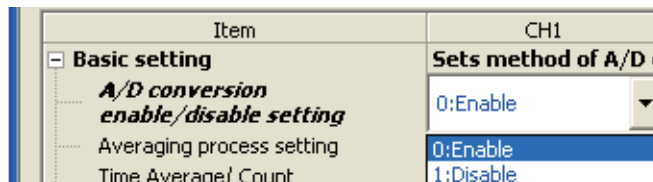

2. Set a value to "Shifting amount to conversion value".

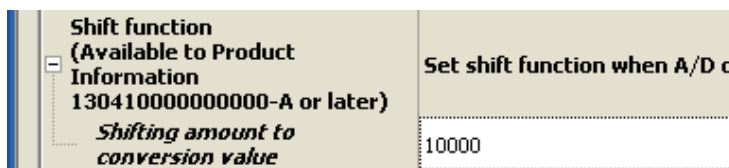

The initial value of the shifting amount to conversion value is 0.

Item	Setting range
Shifting amount to conversion value	-32768 to 32767

Point

If the digital output value exceeds the range of -32768 to 32767 as a result of shift addition, the digital output value is fixed to the lower limit value (-32768) or the upper limit value (32767).

(3) Setting example

Ex. When the following settings are used for a channel with input range of -10 to 10V:

- "Shifting amount to conversion value": 20000

The following figure and table show CH1 Digital output value (Un\G11) and CH1 Scaling value (digital operation value) (Un\G54).

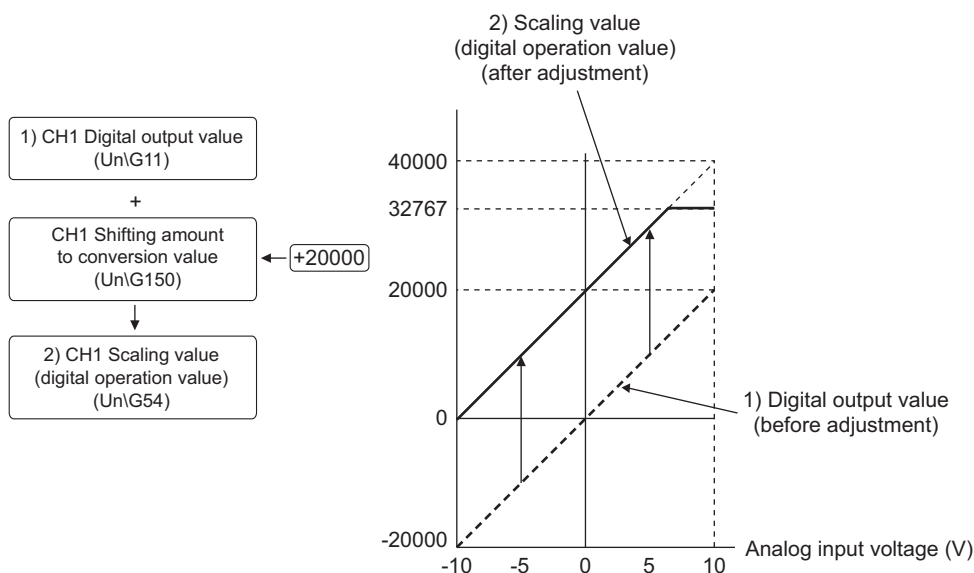

Input voltage (V)	CH1 Digital output value (Un\G11)	CH1 Scaling value (digital operation value) (Un\G54)
-10	-20000	0
-5	-10000	10000
0	0	20000
5	10000	30000
10	20000	32767 ^{*1}

*1 Since the value exceeds the range of -32768 to 32767, it is fixed to 32767 (the upper limit value).

(4) Setting example of when both the scaling function and shift function is used

Ex. When the following settings are used for the A/D converter module with input range of 0 to 5V:

- "Scaling upper limit value": 12000
- "Scaling lower limit value": 2000
- "Shifting amount to conversion value": 2000

1. Set "A/D conversion enable/disable setting" to "0: Enable".

Project window ⇨ [Intelligent Function Module] ⇨ module name ⇨ [Parameter]

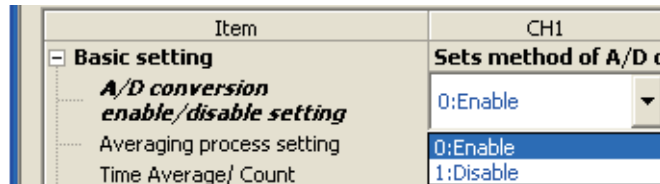

2. Set "Scaling enable/disable setting" to "0: Enable".

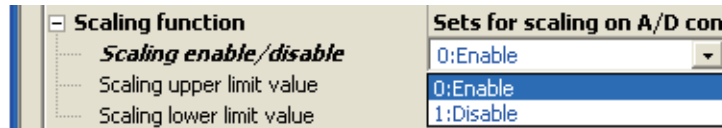

3. Set values for "Scaling upper limit value" and "Scaling lower limit value".

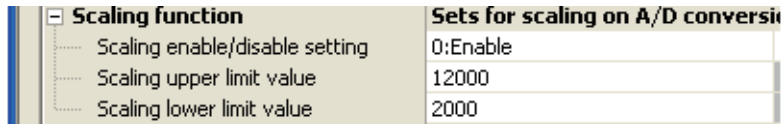

4. Set a value to "Shifting amount to conversion value".

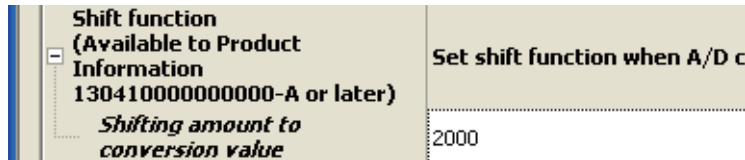

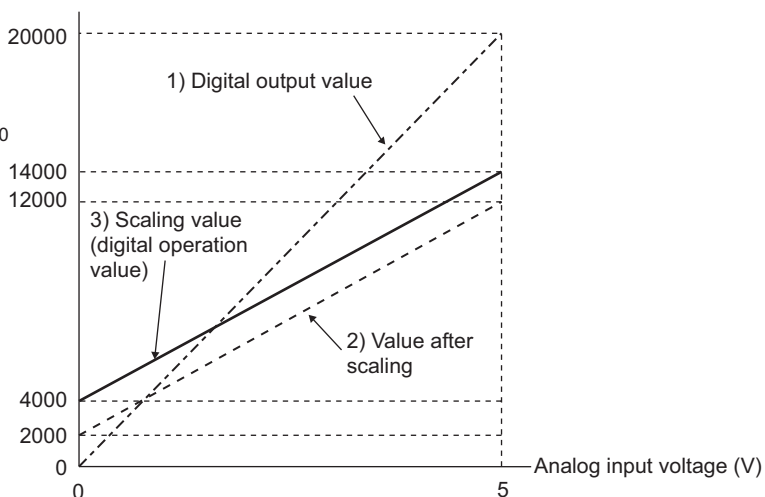
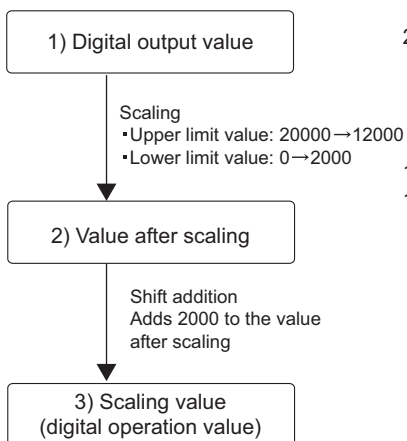

Input voltage (V)	Digital output value	Value after scaling	Scaling value (digital operation value)
0	0	2000	4000
1	4000	4000	6000
2	8000	6000	8000
3	12000	8000	10000
4	16000	10000	12000
5	20000	12000	14000

Point

When the shift function is used with the digital clipping function and scaling function, shift addition is executed on the value after digital clipping and scale conversion. Therefore, the range of the scaling value (digital operation value) is determined as -32768 to 32767. For a setting example of when the digital clipping function, scaling function, and shift function are used together, refer to the following.

- Setting example of when the digital clipping function, scaling function, and shift function are used together (☞ Page 92, Section 8.12 (4))

8.12 Digital Clipping Function

The range of the scaling value (digital operation value) for voltage or current over the input range is fixed between the maximum digital output value and the minimum digital output value.

(1) Concept of digital clipping setting

The following table lists the output range of the scaling value (digital operation value) when the digital clipping function is enabled for each range.

Input range	Output range of the scaling value (digital operation value)	
	Digital clipping function enabled	Digital clipping function disabled
4 to 20mA	0 to 20000	-480 to 20479
0 to 20mA		
1 to 5V		
0 to 5V		
0 to 10V		
-10 to 10V	-20000 to 20000	-20480 to 20479
User range setting		
4 to 20mA (Extended mode)	-5000 to 22500	-5480 to 22979
1 to 5V (Extended mode)		

(2) Setting procedure

1. Set "A/D conversion enable/disable setting" to "0: Enable".

 Project window ⇨ [Intelligent Function Module] ⇨ module name ⇨ [Parameter]

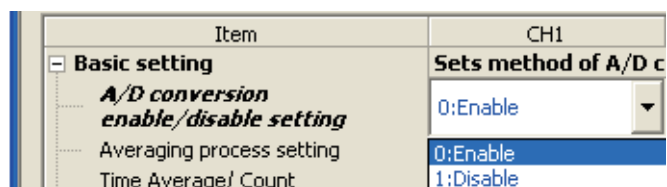

2. Set "Digital clipping function enable/disable setting" to "0: Enable".

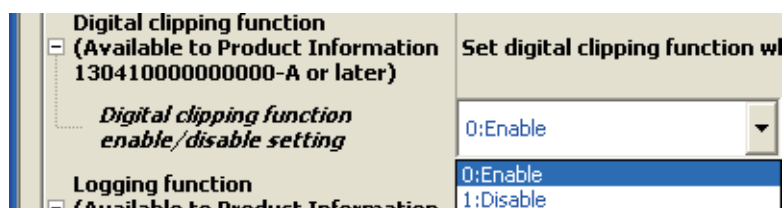

(3) Setting example of when both the digital clipping function and scaling function are used

Ex. When setting as follows for the A/D converter module with input range of 0 to 5V:

- "Scaling upper limit value": 32000
- "Scaling lower limit value": 0
- "Digital clipping function enable/disable setting": "0: Enable"

1. Set "A/D conversion enable/disable setting" to "0: Enable".

 Project window ⇒ [Intelligent Function Module] ⇒ module name ⇒ [Parameter]

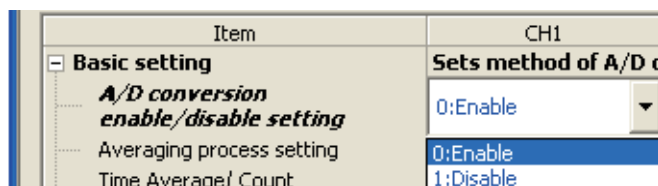

2. Set "Scaling enable/disable setting" to "0: Enable".



3. Set values for "Scaling upper limit value" and "Scaling lower limit value".

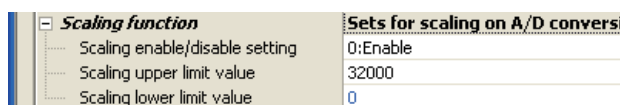

4. Set "Digital clipping function enable/disable setting" to "0: Enable".

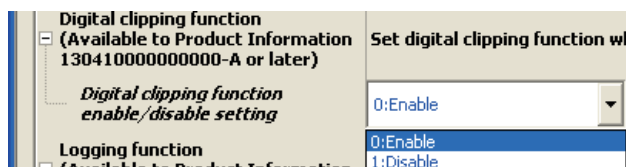

In this case, scale conversion is performed on the digital-clipped scaling value (digital operation value). Therefore, the digital output range of the scaling value (digital operation value) is determined as 0 to 32000.

(4) Setting example of when the digital clipping function, scaling function, and shift function are used together

Ex. When setting as follows for the A/D converter module with input range of 0 to 5V:

- "Scaling upper limit value": 12000
- "Scaling lower limit value": 2000
- "Shifting amount to conversion value": 2000
- "Digital clipping function enable/disable setting": "0: Enable"

1. Set "A/D conversion enable/disable setting" to "0: Enable".

Project window ⇨ [Intelligent Function Module] ⇨ module name ⇨ [Parameter]

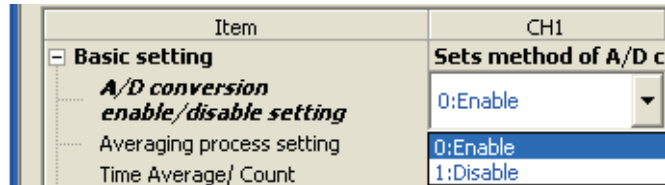

2. Set "Scaling enable/disable setting" to "0: Enable".

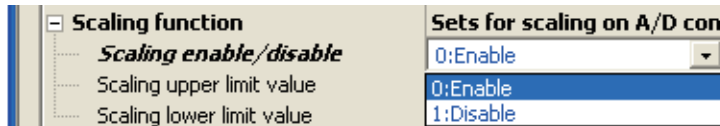

3. Set values for "Scaling upper limit value" and "Scaling lower limit value".

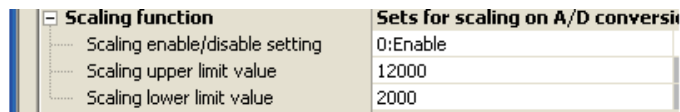

4. Set a value to "Shifting amount to conversion value".

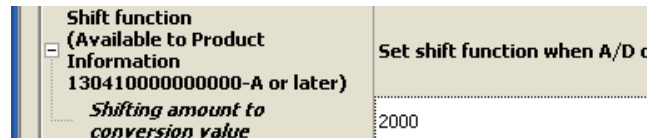

5. Set "Digital clipping function enable/disable setting" to "0: Enable".

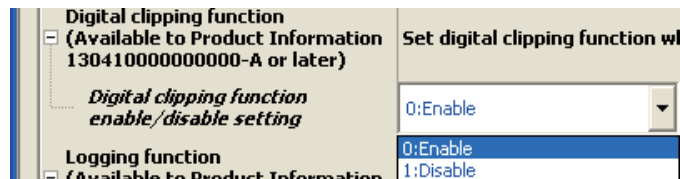

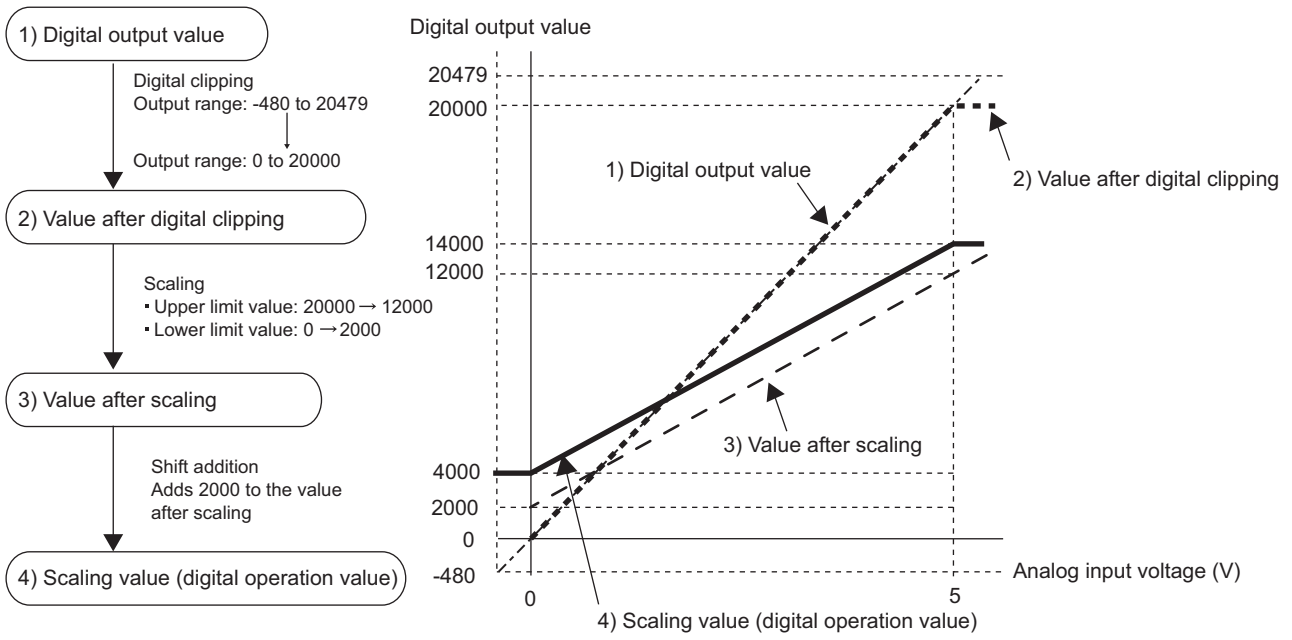

Input voltage (V)	Digital output value	Scaling value (digital operation value)
-0.12	-480	4000
0	0	4000
1	4000	6000
2	8000	8000
3	12000	10000
4	16000	12000
5	20000	14000
5.12	20479	14000

Point

When the digital clipping function is used with the scaling function, shift function, and difference conversion function, the scale conversion, shift addition, and difference conversion are executed on the value after digital clipping. For details, refer to the following.

- Processing each function (☞ Page 61, Section 8.1)

8.13 Difference Conversion Function

The scaling value (digital operation value) at the start of this function is treated as 0 (reference value). Thereafter, values that increase or decrease from the reference value are stored in the buffer memory.

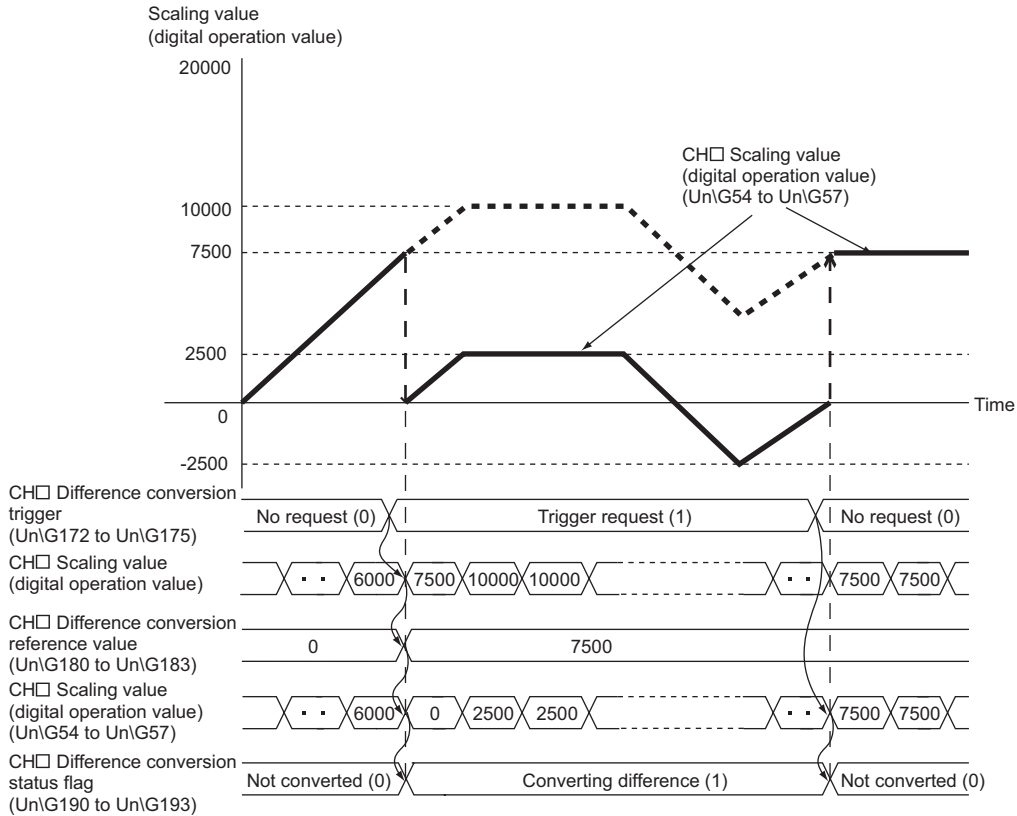

(1) Operation of the difference conversion function

When the difference conversion starts, the scaling value (digital operation value) at that time (the data stored inside the A/D converter module before difference conversion) is determined as the difference conversion reference value. The value acquired by subtracting the difference conversion reference value from the scaling value (digital operation value) is stored in CH Scaling value (digital operation value) (UnG54 to UnG57). Therefore, CH Scaling value (digital operation value) (UnG54 to UnG57) at the start of this function is 0. (since the scaling value (digital operation value) equals to the difference conversion reference value at the start)

$$\text{Scaling value (digital operation value) after difference conversion} = \text{Scaling value (digital operation value)} - \text{Difference conversion reference value}$$

(2) How to use difference conversion

(a) Starting difference conversion

1. Change CH Difference conversion trigger (UnG172 to UnG175) from No request (0) to Trigger request (1).

The rise of No request (0) → Trigger request (1) is detected as a trigger. When the trigger is detected, the scaling value (digital operation value) at the start is output to the difference conversion reference value. The value acquired by subtracting the difference conversion reference value from the scaling value (digital operation value) is stored in CH Scaling value (digital operation value) (UnG54 to UnG57). After the value is stored, CH Difference conversion status flag (UnG190 to UnG193) changes to Converting difference (1).

(b) Stopping difference conversion

1. Change CH□ Difference conversion trigger (Un\G172 to Un\G175) from Trigger request (1) to No request (0).

The fall of Trigger request (1) → No request (0) is detected as a trigger. When the trigger is detected, the difference conversion stops, and CH□ Difference conversion status flag (Un\G190 to Un\G193) changes to Not converted (0). After that, the scaling value (digital operation value) is stored as it is in CH□ Scaling value (digital operation value) (Un\G54 to Un\G57).

(3) Points for the use of the difference conversion function

(a) Operation of when an input signal error occurs

While an input signal error is occurring, even if Difference conversion trigger (Un\G172 to Un\G175) changes No request (0) → Trigger request (1), the difference conversion does not start. After the analog input value returns within the setting range, change Difference conversion trigger (Un\G172 to Un\G175) from No request (0) to Trigger request (1) again. If an input signal error occurs in the status of Trigger request (1), the difference conversion starts just when the analog input value returns within the setting value, treating the scaling value (digital operation value) as the difference conversion reference value.

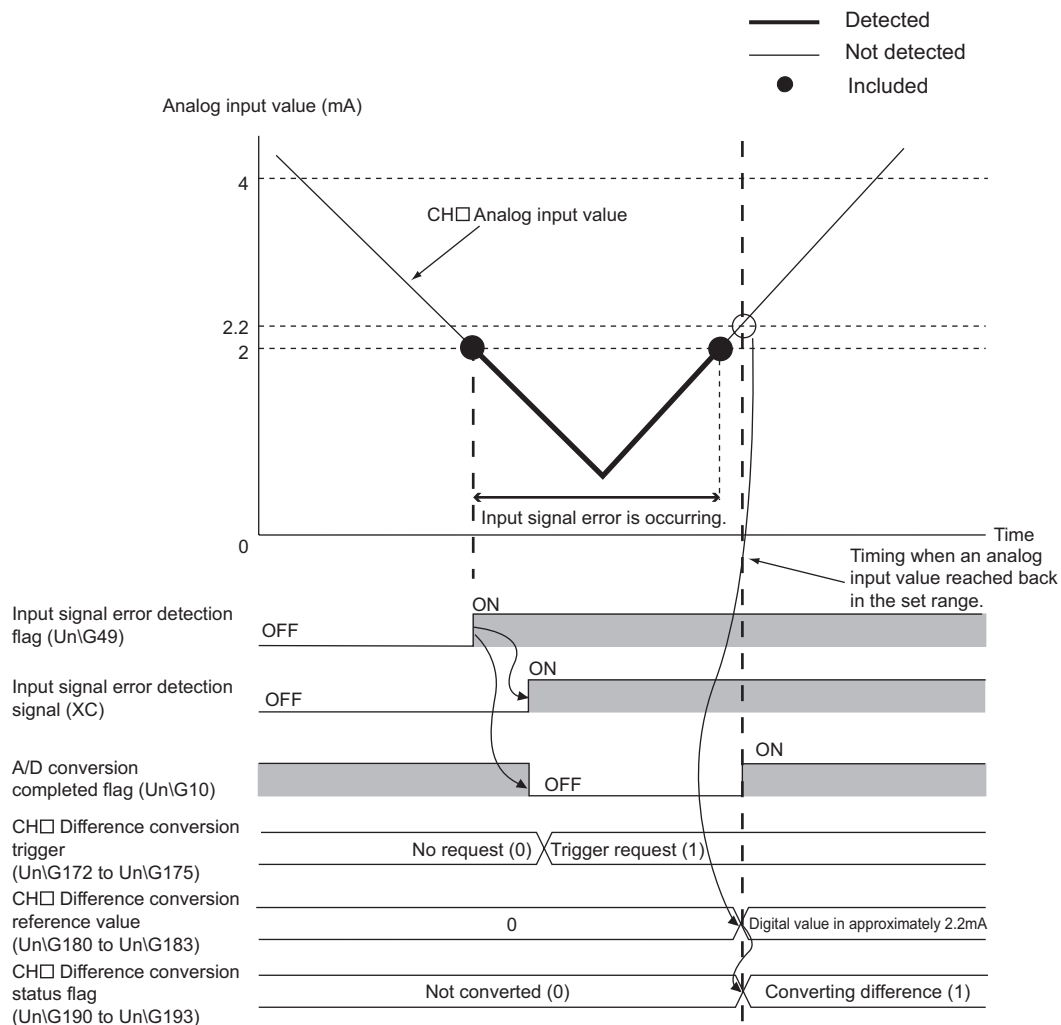

(b) Operation of when Operating condition setting request (Y9) is turned OFF → ON → OFF during difference conversion

During the difference conversion, even if Operating condition setting request (Y9) is turned OFF → ON → OFF, the difference conversion before Operating condition setting request (Y9) continues and the difference conversion reference value is not updated. To update the difference conversion reference value, restart the difference conversion by changing Difference conversion trigger Trigger request (1) → No request (0) → Trigger request (1) again.

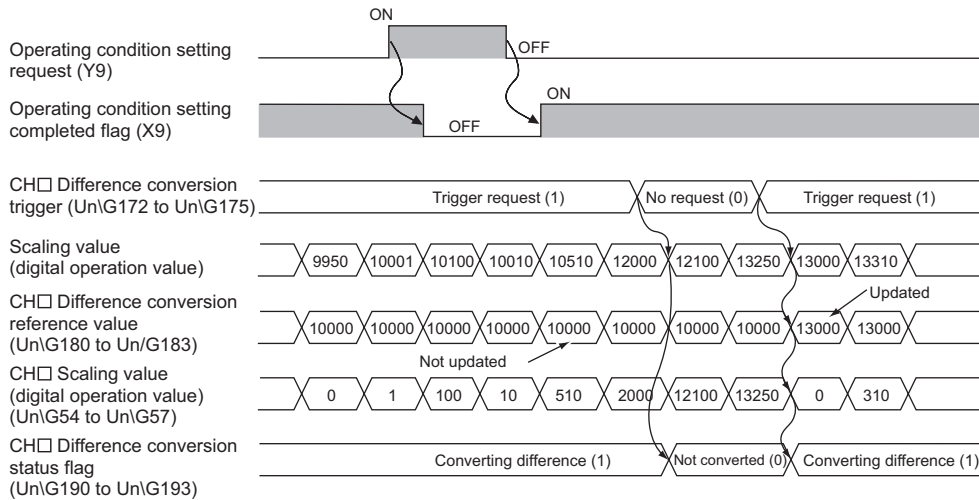

(c) Operation of the maximum value and the minimum value

When the difference conversion starts, the maximum value and the minimum value of the values acquired by the difference conversion are stored in CH□ Maximum value and CH□ Minimum value. By turning on Maximum value/minimum value reset request (YD), the maximum value and the minimum value after the start of the difference conversion can be checked.

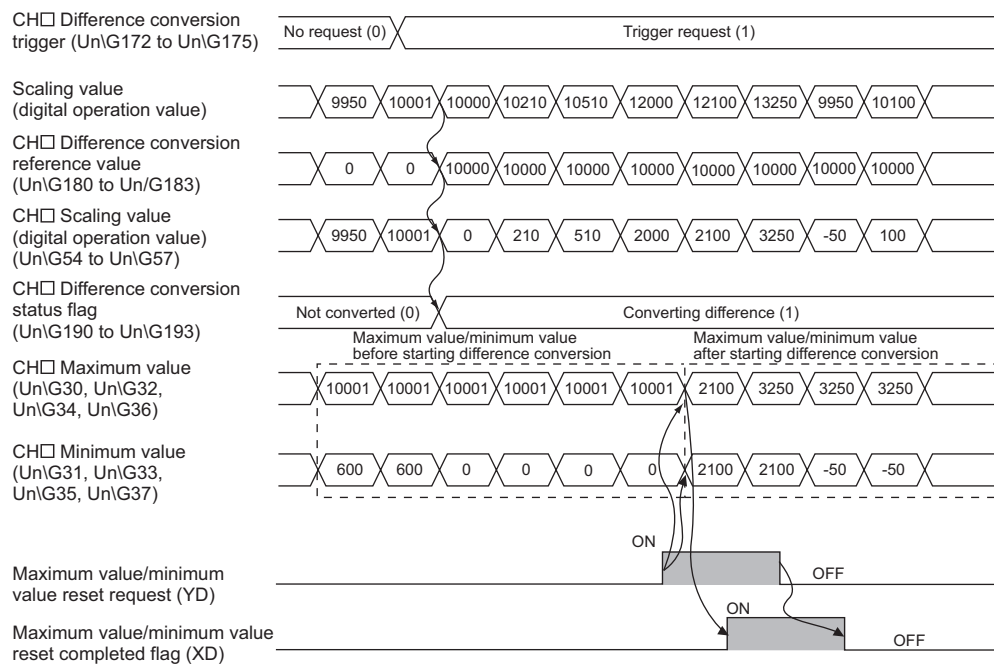

(d) Operation of when the averaging processing is set

If the difference conversion starts while the averaging processing is set, the scaling value (digital operation value) at the completion of the averaging processing is determined as the difference conversion reference value. In addition, CH□ Difference conversion status flag (Un\G190 to Un\G193) changes to Converting difference (1).

Point 

- The difference conversion function can be started at any timing.
- When the difference conversion function is used with the digital clipping function, scaling function, and shift function, each scaling value (digital operation value) is determined as a difference conversion reference value.
- If other than No request (0) or Trigger request (1) is set in CH□ Difference conversion trigger (Un\G172 to Un\G175) during the difference conversion, an error occurs. Though the difference conversion continues.
- Even if the digital clipping function, scaling function, and shift function are set valid, the difference conversion reference value is not updated. To update the difference conversion reference value, stop the difference conversion and restart it.

8.14 Logging Function

Using this function, data can be consecutively collected at a set cycle and they can be stored in the buffer memory. Using the data stored in the buffer memory, debugging can be performed and the data variation can be checked periodically.

In addition, the time-series data imported as logs can be easily checked.

(1) Logging function

(a) Collectable data

The following two kinds of data can be collected.

- Digital output value
- Scaling value (digital operation value)

(b) Collectable points

Up to 10000 points logging data can be stored for each channel.

(c) Collection cycle

The data can be collected at intervals of 80µs at the minimum and of 3600s at the maximum.

For details of the collection cycle, refer to the following.

- Setting procedure (☞ Page 100, Section 8.14 (3))

(d) Storing the collected data

Logging data are stored orderly in the logging data storage area of the buffer memory, starting from the head of the area.

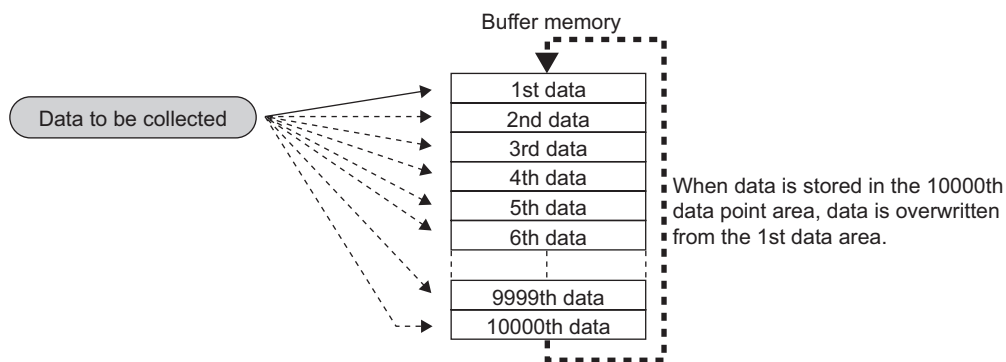

(2) Logging procedure

(a) Use conditions of the logging function

To use the logging function, set as follows.

Item	Setting
Conversion speed	80 μ s, or 1ms
Input signal error detection function	Disable
Input signal error detection extension function	Disable

(b) Starting logging and checking procedure of logging data

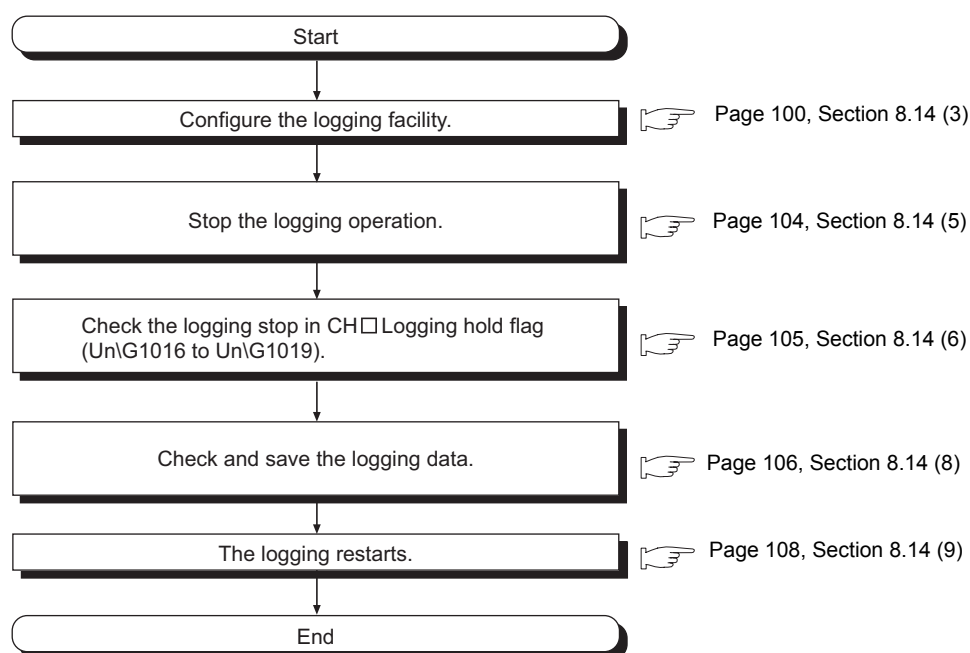

Point

Logging data can also be checked without stopping logging. For details, refer to the following.

- When checking logging data without stopping logging (Page 109, Section 8.14 (10))

(3) Setting procedure

1. Set "A/D conversion enable/disable setting" to "0: Enable".

Project window ⇨ [Intelligent Function Module] ⇨ module name ⇨ [Parameter]

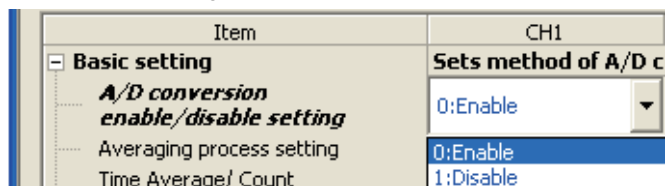

2. Set "Logging enable/disable setting" to "0: Enable".

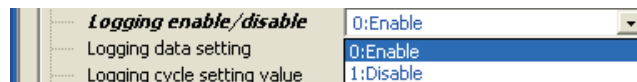

3. Set the logging target in "Logging data setting".

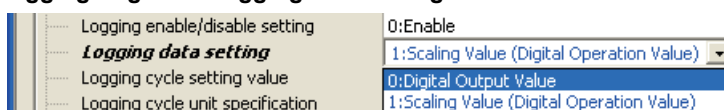

4. Set the cycle of storing logging data in "Logging cycle setting value".



5. Set the unit of the "Logging cycle setting value" in "Logging cycle unit specification".

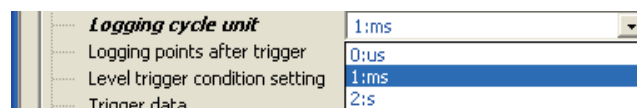

The following table lists the setting ranges.

"Logging cycle unit specification"	Setting range of "Logging cycle setting value"
0: μ s	80 to 32767
1: ms	1 to 32767
2: s	1 to 3600

The actual logging cycle is "an integral multiple of the conversion cycle of each A/D conversion method".

The following table lists the conversion cycle of each A/D conversion method.

A/D conversion method	The conversion cycle
Sampling processing	Conversion speed × Number of used channels
Time average	$\left(\frac{\text{Time set in "Time Average/Count Average/Moving Average"}}{\text{Conversion speed} \times \text{Number of used channels}} \right)^{*1} \times \text{Conversion speed} \times \text{Number of used channels}$
Count average	Number of times set in "Time Average/ Count Average/Moving Average" × Conversion speed × Number of used channels
Moving average	Conversion speed × Number of used channels

*1 The value after the decimal point is rounded off.

If the set logging cycle is not an integral multiple of the conversion cycle shown above, the logging function operates in the maximum cycle of an integral multiple within the setting range.

Ex. When setting as follows in CH1 to CH3:

- "Averaging process setting": "0: Sampling Processing"
- "Conversion speed setting": "1: 80μs"
- "Logging data setting": "0: Digital Output Value"
- "Logging cycle setting value": 7000
- "Logging cycle unit specification": "0: μs"

$$80 \times 3 = 240\mu\text{s}$$

The actual logging cycle is 6960μs (an integral multiple of 240μs).

The actual logging cycle can be checked at CH□ Logging cycle monitor value (Un\G1122 to Un\G1133)

6. In "Logging points after trigger", set the data points to be collected from stop request (hold trigger) for logging occurs until logging stops.



The following table lists the setting range of the "Logging points after trigger".

Item	Setting range
Logging points after trigger	1 to 10000

7. In "Level trigger condition setting", select any of the following.

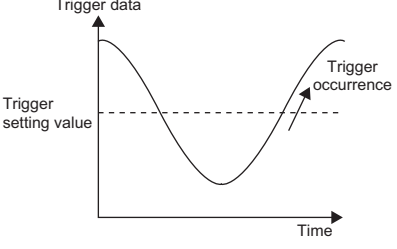
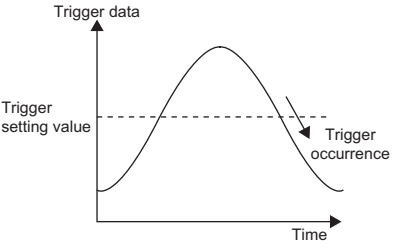
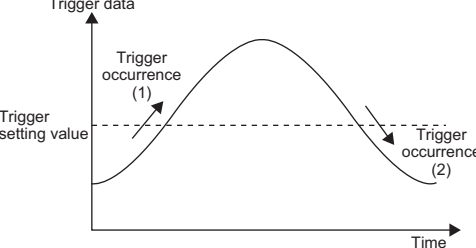
Setting value	Description											
0: Disable	Select when a stop condition of logging is not set. (Logging can be stopped at any timing.)											
1: Above	<p>Select a value to set a stop condition of logging. (Logging stops when the value in the buffer memory satisfies the set condition.)</p>	<p>Logging stops when the status of "Trigger data < Trigger setting value" turns to that of "Trigger data > Trigger setting value"</p>  <p>Example When the trigger setting value is 70</p> <table border="1" data-bbox="1093 481 1236 683"> <thead> <tr> <th>Trigger data</th> </tr> </thead> <tbody> <tr><td>64</td></tr> <tr><td>66</td></tr> <tr><td>67</td></tr> <tr><td>69</td></tr> <tr><td>70</td></tr> <tr><td>71</td></tr> <tr><td>72</td></tr> <tr><td>74</td></tr> <tr><td>...</td></tr> </tbody> </table> <p>← Trigger occurs at this point</p>	Trigger data	64	66	67	69	70	71	72	74	...
Trigger data												
64												
66												
67												
69												
70												
71												
72												
74												
...												
2: Below	<p>Logging stops when the status of "Trigger data > Trigger setting value" turns to that of "Trigger data < Trigger setting value"</p>  <p>Example When the trigger setting value is 70</p> <table border="1" data-bbox="1093 817 1236 1019"> <thead> <tr> <th>Trigger data</th> </tr> </thead> <tbody> <tr><td>74</td></tr> <tr><td>72</td></tr> <tr><td>71</td></tr> <tr><td>70</td></tr> <tr><td>69</td></tr> <tr><td>67</td></tr> <tr><td>66</td></tr> <tr><td>64</td></tr> <tr><td>...</td></tr> </tbody> </table> <p>← Trigger occurs at this point</p>	Trigger data	74	72	71	70	69	67	66	64	...	
Trigger data												
74												
72												
71												
70												
69												
67												
66												
64												
...												
3: Pass Through	<p>Logging stops when the trigger data passes the trigger setting value. (Either of the following (1) or (2))</p> <p>(1) When the status of "Trigger data < Trigger setting value" turns to that of "Trigger data > Trigger setting value"</p> <p>(2) When the status of "Trigger data > Trigger setting value" turns to that of "Trigger data < Trigger setting value"</p> 											

8. When other than "0: Disable" in "Level trigger condition setting" is selected, set the stop condition of logging with "Trigger data" and "Trigger setting value".

Item	Description
Trigger data	Set the buffer memory address monitored as a occurrence condition to stop logging.*1
Trigger setting value	Set the value of the buffer memory to stop logging.

*1 By setting Level data □ (Un\G1072 to Un\G1081) as a monitoring target, a device value of a CPU module can be set as a trigger data.

For details on the Level data, refer to the following.

- Level data (☞ Page 194, Appendix 2(38))

Point

- While "Conversion speed" is set as 20μs (0), setting CH□ Logging enable/disable setting (Un\G1000 to Un\G1003) to 0: Enable causes an error.
- When the input signal error detection function and the input signal error detection extension function are set, setting CH□ Logging enable/disable setting (Un\G1000 to Un\G1003) to Enable (0) causes an error.
- If the logging cycle setting value and the logging cycle set in the logging cycle input setting are below the digital output value and the cycle of updating the scaling value (digital operation value), an error occurs and logging cannot be performed.
- When the logging function turns disabled
The logging function turns disabled when any of the following error occurs after the logging function is enabled and Operating condition setting request (Y9) is turned OFF → ON → OFF.
 - Error code (20□): Setting error of CH□ Time Average/ Count Average/Moving Average (Un\G1 to Un\G4)
 - Error code (30□): Setting error of CH□ Time Average/ Count Average/Moving Average (Un\G1 to Un\G4)
 - Error code (31□): Setting error of CH□ Time Average/ Count Average/Moving Average (Un\G1 to Un\G4)
 - Error code (360): Setting error of Conversion speed setting (Un\G26)
 - Error code (200□ to 208□): Setting error of a parameter setting item of the logging function

(4) Starting logging

Turn Operating condition setting request (Y9) OFF → ON → OFF. Data is logged at every set logging cycle.

(5) Stopping logging

Use a hold trigger to stop logging. After the hold trigger is detected, the A/D converter module stops collecting data after logging for points that is previously set.

Logging stopping method are as follows.

1. Turn CH□ Logging hold request (Un\G1008 to Un\G1011) from No request (0) to Requested (1).

When "Level trigger condition setting" is set to "0: Disable", the data corresponding to the set points are collected and logging stops.

When "Level trigger condition setting" is set to other than "0: Disable", data corresponding to set points are collected after the conditions of "Trigger data" and "Trigger setting value" are satisfied, and logging stops.

Point

- When Operating condition setting request (Y9) is turned on, logging stops regardless of ON or OFF of the hold trigger. All the logging data stored before turning on Operating condition setting request (Y9) are cleared.
- Turn CH□ Logging hold request (Un\G1008 to Un\G1011) Requested (1) → No request (0) after confirming CH□ Logging hold flag (Un\G1016 to Un\G1019) turns Logging held (1). If CH□ Logging hold request (Un\G1008 to Un\G1011) is turned Requested (1) → No request (0) before holding, logging does not stop.
- The following delay occurs at the maximum until the A/D converter module receives a hold trigger after CH□ Logging hold request (Un\G1008 to Un\G1011) is turned No request (0) → Requested (1).
Trigger delay = Logging cycle (Cycle at which logging is actually performed) + Scan time of CPU module

Ex. When "Level trigger condition setting" is set to "0: Disable" and CH1 Scaling value (digital operation value) (Un\G54) is logged

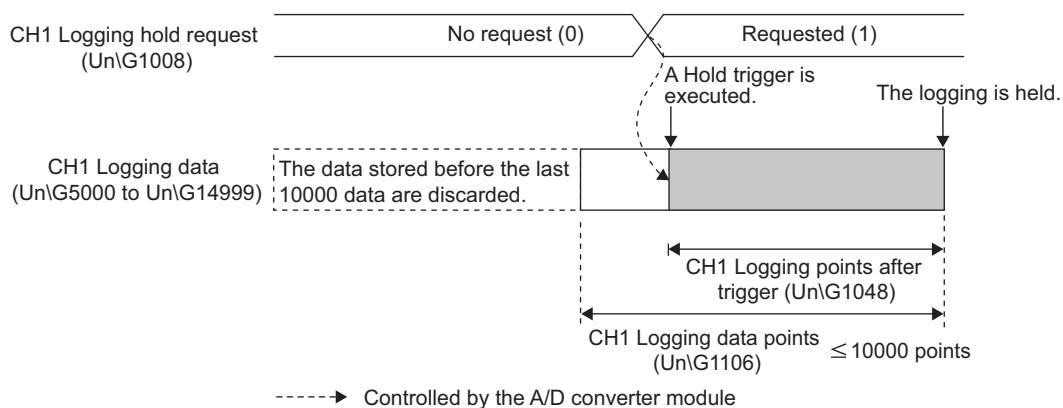

Ex. When "Level trigger condition setting" is set to other than "0: Disable" and CH1 Scaling value (digital operation value) (Un\G54) is logged

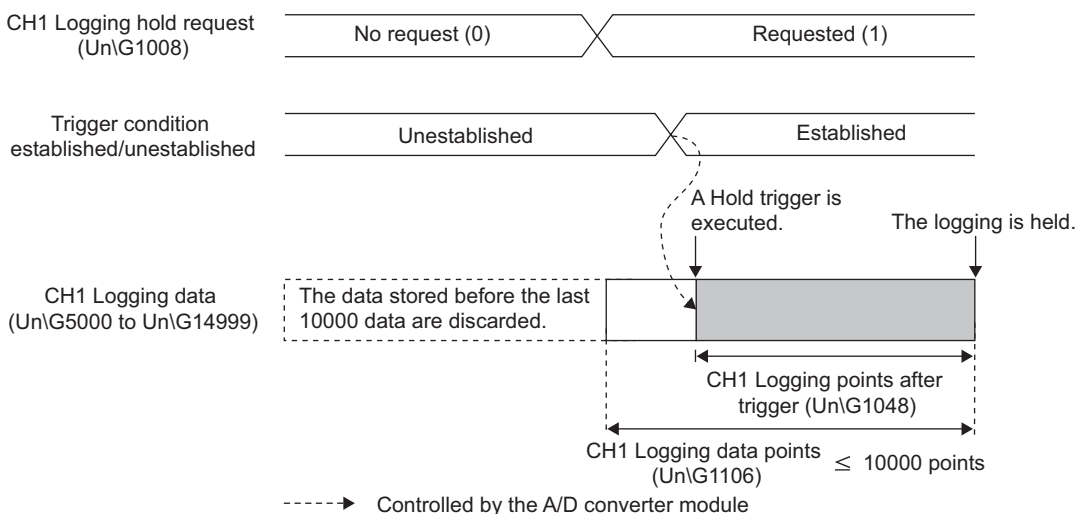

(6) Confirming stop of logging

Confirm that CH□ Logging hold flag (Un\G1016 to Un\G1019) turns Logging held (1).

(7) Checking trigger detection time

The time that the hold trigger is detected can be checked in the buffer memory. Even when the logging cycle is set as less than 1s, the minimum time unit recorded in the Trigger detection time (Un\G1154 to Un\G1157) is second. Use trigger detection time as an indication to refer to the logging data. For the buffer memory areas in which trigger detection time is recorded, refer to the following.

Channel	Address for trigger detection time
CH1	CH1 Trigger detection time (Un\G1154 to Un\G1157)
CH2	CH2 Trigger detection time (Un\G1158 to Un\G1161)
CH3	CH3 Trigger detection time (Un\G1162 to Un\G1165)
CH4	CH4 Trigger detection time (Un\G1166 to Un\G1169)

Ex. For CH1 Trigger detection time (Un\G1154 to Un\G1157)

	b15	to	b8	b7	to	b0
Un\G1154	First two digits of the year			Last two digits of the year		
Un\G1155	Month			Day		
Un\G1156	Hour			Minute		
Un\G1157	Second			Day of the week		

Item	Storage contents	Storage example*1
First two digits of the year/ Last two digits of the year	Stored in BCD code.	2011 _H
Month/Day		329 _H
Hour/Minute		1035 _H
Second		40 _H
Day of the week	One of the following value is stored for each day of the week in BCD code. <ul style="list-style-type: none"> • Sunday: 0 • Monday: 1 • Tuesday: 2 • Wednesday: 3 • Thursday: 4 • Friday: 5 • Saturday: 6 	2 _H

*1 Those are values when a hold trigger is detected at 10:35:40 on Tuesday, March 29th, 2011.

(8) Checking logging data

Logging data are stored in the following buffer memory areas.

Channel	Collectable data		Storing destination of logging data	
	Buffer memory name	Buffer memory address	Buffer memory name	Buffer memory address
CH1	CH□ Digital output value	Un\G11	CH□ Logging data	Un\G5000 to Un\G14999
CH2		Un\G12		Un\G15000 to Un\G24999
CH3		Un\G13		Un\G25000 to Un\G34999
CH4		Un\G14		Un\G35000 to Un\G44999
CH1	CH□ Scaling value (digital operation value)	Un\G54		Un\G5000 to Un\G14999
CH2		Un\G55		Un\G15000 to Un\G24999
CH3		Un\G56		Un\G25000 to Un\G34999
CH4		Un\G57		Un\G35000 to Un\G44999

1. Check the number of valid logging data in CH□ Number of logging data (Un\G1106 to Un\G1109).

When data is collected 10000 times or less

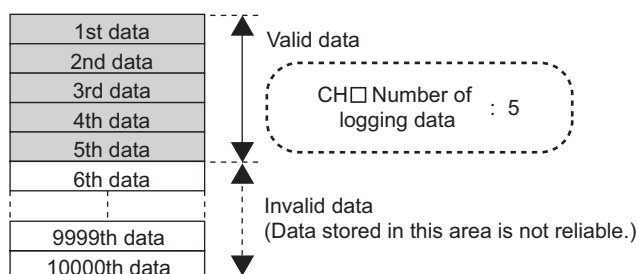

When data is collected 10001 times or more

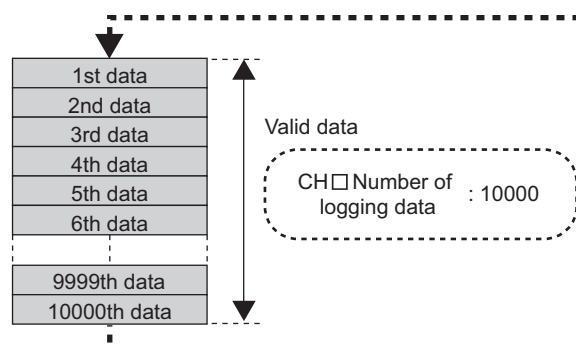

2. Check the places where the latest data and the oldest data are stored.

Those places can be checked in the following buffer memory areas.

- CH□ Head pointer (Un\G1090 to Un\G1093) (☞ Page 195, Appendix 2(40))
- CH□ Latest pointer (Un\G1098 to Un\G1101) (☞ Page 195, Appendix 2(41))

Ex. When data is collected 10001 times or more

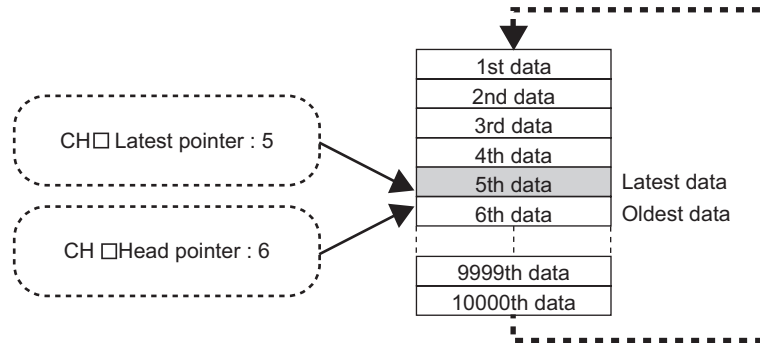

3. Check the storage location when logging stops with CH□ Trigger pointer (Un\G1114 to Un\G1117).

Ex. When logging stops under the following conditions

- CH□ Logging points after trigger (Un\G1048 to Un\G1051): 6505 points
- Logging hold request: Performed at 3500th

(Because of the above condition, the hold location is determined as 5th.)

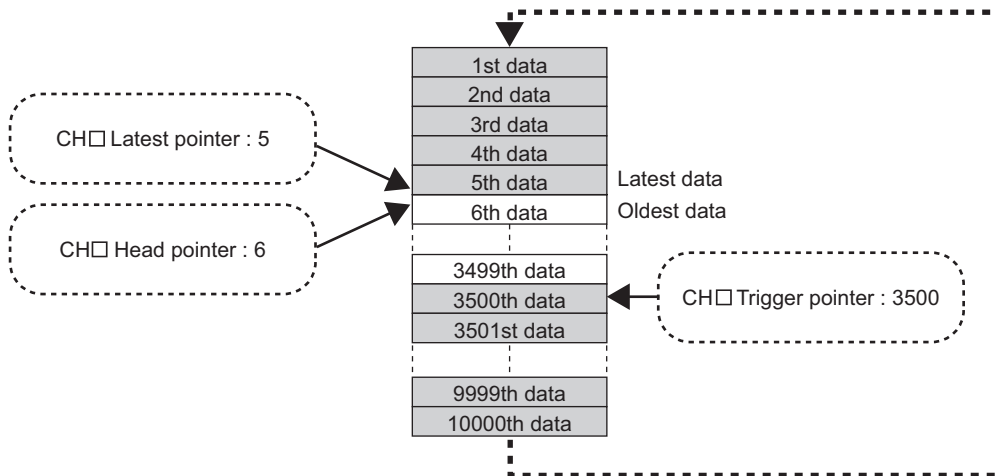

(9) Restarting logging

To restart logging, turn CH□ Logging hold request (Un\G1008 to Un\G1011) ON → OFF. Logging is restarted from the head of the logging data storage area.

At this time, head pointer, trigger pointer, and the number of logging data are cleared, and CH□ Logging hold flag (Un\G1016 to Un\G1019) turns off.

(a) Precautions

- It may take time for CH□ Logging hold flag (Un\G1016 to Un\G1019) to turn on after CH□ Logging hold request (Un\G1008 to Un\G1011) is turned OFF → ON. To restart logging, turn CH□ Logging hold request (Un\G1008 to Un\G1011) ON → OFF after confirming CH□ Logging hold flag (Un\G1016 to Un\G1019) turns on.

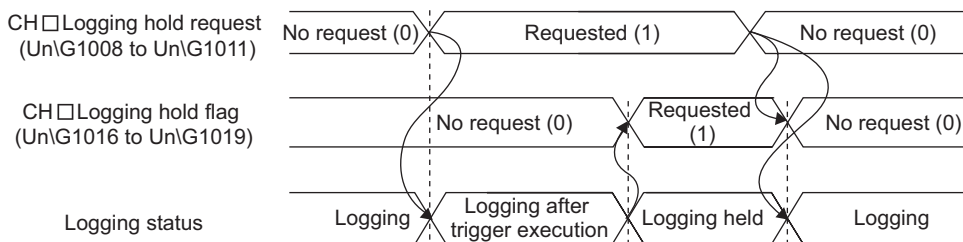

- If CH□ Logging hold request (Un\G1008 to Un\G1011) is turned ON → OFF before CH□ Logging hold flag (Un\G1016 to Un\G1019) turns on, logging does not stop.

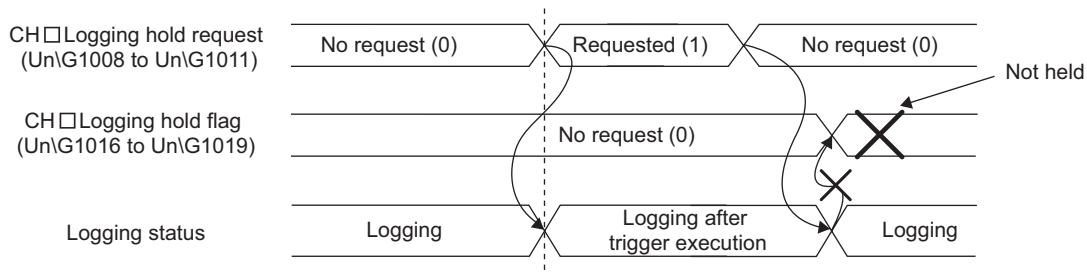

(b) Each buffer memory when logging is restarted

When logging resumes, the value in each buffer memory area below is as follows.

Buffer memory	Value status
CH□ Head pointer (Un\G1090 to Un\G1093)	Values are initialized. (Initial value: 0)
CH□ Latest pointer (Un\G1098 to Un\G1101)	
CH□ Number of logging data (Un\G1106 to Un\G1109)	
CH□ Trigger pointer (Un\G1114 to Un\G1117)	
CH□ Logging data (Un\G5000 to Un\G44999)	The value before logging is restarted is maintained.*1

*1 After logging is restarted, values are stored starting from the head buffer memory of the logging data storage area. Since the value before logging is restarted is stored in CH□ Logging data (Un\G5000 to Un\G44999), check the valid data with CH□ Number of logging data (Un\G1106 to Un\G1109) to refer to the logging data.

(10)When checking logging data without stopping logging

Logging data can be checked during logging. Logging data can be easily checked on a display device just by monitoring the buffer memory without stopping logging on the display device.

To check the logging data, adjust the logging cycle to prevent the logging data from being updated during read.

(a) Checking method

Read the logging data monitoring the storage locations of the latest data and of the oldest data in the following buffer memory areas.

Buffer memory	Description	Reference
CH□ Head pointer (Un\G1090 to Un\G1093)	The buffer memory where the oldest data is stored can be checked by number starting from the start address in the logging data storage area.	Page 195, Appendix 2(40)
CH□ Latest pointer (Un\G1098 to Un\G1101)	The buffer memory where the latest data is stored can be checked by number starting from the start address in the logging data storage area.	Page 195, Appendix 2(41)
CH□ Number of logging data (Un\G1106 to Un\G1109)	The number of data stored in the logging data storage area can be checked.	Page 196, Appendix 2(42)

(b) Precautions

- Set CH□ Logging cycle setting value (Un\G1032 to Un\G1035) to the cycle that confirmation and read of data surely complete before logging data is updated. If the logging cycle is short, logging data may be updated while confirming and reading data.
- After acquiring the logging data which need to be checked, monitor the variation of the head pointer and the number of logging data. Acquire logging data after the stored value changes.
- If the update of the data and the data being checked do not synchronize due to the relationship between the logging cycle and the scan time of the CPU module, adjust the logging cycle.
- To check the data without paying attention to logging cycle, use the logging hold.

8.15 Flow Amount Integration Function

This function performs the A/D conversion of analog input value (voltage or current) from a flow meter and others, and integrates the digital output value by every integration cycle. In this function, integral processing is performed regarding the scaling value (digital operation value) as the instantaneous flow amount.

In the flow amount integration function, the conversion speed can be set in 1ms.

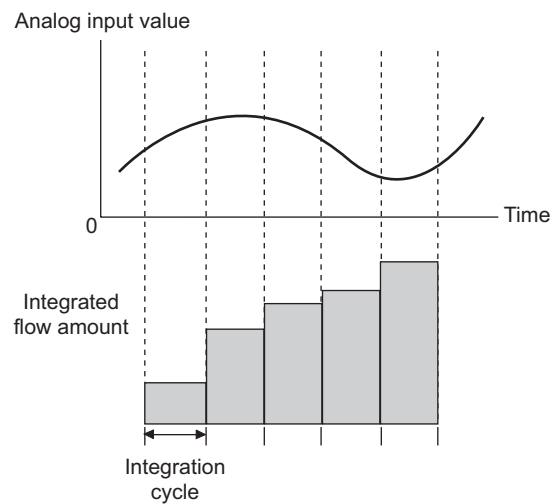
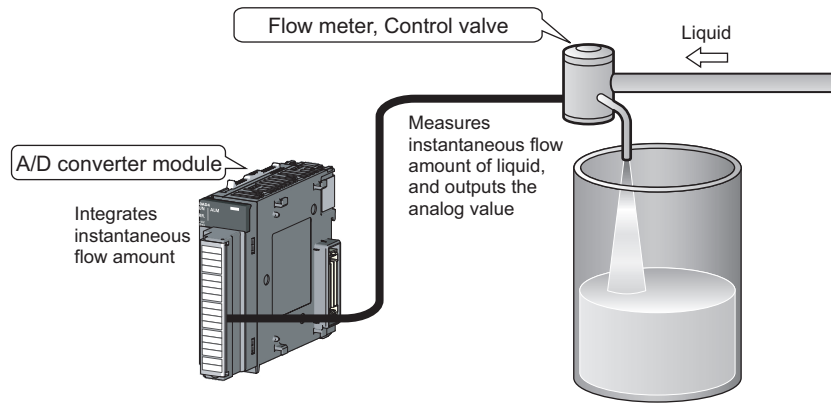

(1) Concept of integral processing

With this function, integral processing is performed using the following formula.

$$\text{Integrated flow amount} = (\text{Instantaneous flow amount} \times \frac{\Delta T}{T} \times \text{Unit scaling}) + \text{Previous amount}$$

Item	Description												
Integrated flow amount	This is a result of the integral processing. The integrated flow amount is stored in CH□ Integrated flow amount (Un\G1332 to Un\G1339) in the range of 0 to 2147483647.												
Instantaneous flow amount	This is an instantaneous flow amount value output in analog from the flow meter. In this function, the value stored in CH□ Scaling value (digital operation value) (Un\G54 to Un\G57) as the instantaneous flow amount.												
ΔT	This is an integration cycle (ms) set in CH□ Integration cycle setting (Un\G1308 to Un\G1311). Set this cycle according to the output cycle of the flow meter connected to the A/D converter module. Ex. When the flow meter outputs instantaneous flow amount in analog at intervals of 500ms, set 500.												
T	This is a conversion value to convert the time unit of instantaneous flow amount to ms. Set this value in CH□ Flow amount time unit setting (Un\G1316 to Un\G1319). Set this cycle according to the range of the flow meter connected to the A/D converter module. The following table lists the values of T for CH□ Flow amount time unit setting (Un\G1316 to Un\G1319). <table border="1" style="margin-left: 20px;"> <thead> <tr> <th>Range of flow meter</th> <th>Setting value of CH□ Flow amount time unit setting (Un\G1316 to Un\G1319)</th> <th>T (ms)</th> </tr> </thead> <tbody> <tr> <td>/s</td> <td>0</td> <td>1000</td> </tr> <tr> <td>/min</td> <td>1</td> <td>60000</td> </tr> <tr> <td>/h</td> <td>2</td> <td>3600000</td> </tr> </tbody> </table> Ex. When the range of the flow meter is cm ³ /s, set /s (0).	Range of flow meter	Setting value of CH□ Flow amount time unit setting (Un\G1316 to Un\G1319)	T (ms)	/s	0	1000	/min	1	60000	/h	2	3600000
Range of flow meter	Setting value of CH□ Flow amount time unit setting (Un\G1316 to Un\G1319)	T (ms)											
/s	0	1000											
/min	1	60000											
/h	2	3600000											
Unit scaling	This is unit scaling of the integrated flow amount. Set this value in CH□ Unit scaling setting (Un\G1324 to Un\G1327). This is used when the value of instantaneous flow amount $\times \Delta T/T$ is 0 to 1. The following table lists the values of unit scaling for CH□ Unit scaling setting (Un\G1324 to Un\G1327). <table border="1" style="margin-left: 20px;"> <thead> <tr> <th>Setting value of CH□ Unit scaling setting (Un\G1324 to Un\G1327)</th> <th>Unit scaling</th> </tr> </thead> <tbody> <tr> <td>0</td> <td>1</td> </tr> <tr> <td>1</td> <td>10</td> </tr> <tr> <td>2</td> <td>100</td> </tr> <tr> <td>3</td> <td>1000</td> </tr> <tr> <td>4</td> <td>10000</td> </tr> </tbody> </table> Ex. When the value of $\Delta T/T$ is 0.0083... ($\Delta T=500(\text{ms})$, $T=60000(\text{ms})$) Set $\times 1000$ (3) or $\times 10000$ (4).	Setting value of CH□ Unit scaling setting (Un\G1324 to Un\G1327)	Unit scaling	0	1	1	10	2	100	3	1000	4	10000
Setting value of CH□ Unit scaling setting (Un\G1324 to Un\G1327)	Unit scaling												
0	1												
1	10												
2	100												
3	1000												
4	10000												
Previous amount	This is a value stored in CH□ Integrated flow amount (Un\G1332 to Un\G1339) before integral processing.												

Point

- If the instantaneous flow amount is less than 0, integral processing is not performed.
- The value acquired by rounding off the part after the decimal point is stored in CH□ Integrated flow amount (Un\G1332 to Un\G1339). (Inside the A/D converter module, calculation is performed including the value after the decimal point in integral processing.)
- The value within the range of 0 to 2147483647 is stored in CH□ Integrated flow amount (Un\G1332 to Un\G1339). If the value exceeds the upper limit (2147483647), the excessive part is stored in CH□ Integrated flow amount (Un\G1332 to Un\G1339).

Ex. When the previous amount is 2147483000 and the present amount (Instantaneous flow amount \times Unit scaling $\times \Delta T/T$) is 5000,
(2147483000 + 5000) - 2147483647 = 4353 is stored in CH□ Integrated flow amount (Un\G1332 to Un\G1339).

(2) Concept of integration cycle

Set the integration cycle according to the analog output cycle of the flow meter connected to the A/D converter module. In addition, set this cycle as an integral multiple of the updating cycle of CH□ Scaling value (digital operation value) (Un\G54 to Un\G57).

The updating cycle of CH□ Scaling value (digital operation value) (Un\G54 to Un\G57) equals to the conversion cycle of the specified A/D conversion method. The following table lists the conversion cycle of each A/D conversion method.

A/D conversion method	Conversion cycle
Sampling processing	Conversion speed ^{*1} × Number of used channels (ms)
Count average processing	$\left(\frac{\text{Time set in "Time Average/Count Average/Moving Average"}^{*2}}{\text{Number of used channels}} \right) \times \text{Conversion speed}^{*1} \times \text{Number of used channels (ms)}$
Time average processing	Number of times set in "Time Average/ Count Average/Moving Average" × Conversion speed ^{*1} × Number of used channels (ms)
Moving average processing	Conversion speed ^{*1} × Number of used channels (ms)

*1 In the flow amount integration function, the conversion speed can be set in 1ms. Therefore, the conversion speed is 1ms.

*2 The value after the decimal point is rounded off.

If the setting value of CH□ Integration cycle setting (Un\G1308 to Un\G1311) is not an integral multiple of the updating cycle of CH□ Scaling value (digital operation value) (Un\G54 to Un\G57), the maximum value of an integral multiple less than the value set in CH□ Integration cycle setting (Un\G1308 to Un\G1311) is calculated as the integration cycle.

Check the calculated integration cycle, which is stored in CH□ Integration cycle monitor value (Un\G1348 to Un\G1351).

Ex. When the integration cycle is calculated with the following settings

- A/D conversion enable in CH1 to CH3
- "Averaging process setting" is "0: Sampling processing"
- "Integration cycle setting" is 5000

Since the updating cycle of CH□ Scaling value (digital operation value) (Un\G54 to Un\G57) is 3ms, the integration cycle is determined as 4998ms (the maximum cycle of an integral multiple of 3ms).

Point

If CH□ Integration cycle setting (Un\G1308 to Un\G1311) is less than the updating cycle of CH□ Scaling value (digital operation value) (Un\G54 to Un\G57), the flow amount integration function turns disabled and an error (error code: 212□) occurs.

(3) Concept of unit scaling

Unit scaling adjusts the number of digits of the integrated flow amount by multiplying "instantaneous flow amount $\times \Delta T/T$ " by a multiple of 10.

Set the unit scaling to store the value after the decimal point of "instantaneous flow amount $\times \Delta T/T$ " in CH□ Integrated flow amount (Un\G1332 to Un\G1339).

Ex. When the value of "instantaneous flow amount $\times \Delta T/T$ " is 123.45

By setting 100 as a unit scaling, the value of "instantaneous flow amount $\times \Delta T/T$ " turns 12345 and the value after the decimal point can be stored in CH□ Integrated flow amount (Un\G1332 to Un\G1339).

The following table lists the indications of the calculated value of $\Delta T/T$ acquired by the combination of CH□ Flow amount time unit setting (Un\G1316 to Un\G1319) and CH□ Integration cycle setting (Un\G1308 to Un\G1311) and the value set in CH□ Unit scaling setting (Un\G1324 to Un\G1327).

Setting value of CH□ Flow amount time unit setting (Un\G1316 to Un\G1319) (T)	Setting value of CH□ Integration cycle setting (Un\G1308 to Un\G1311) (ΔT)	$\Delta T/T$	Indication of unit scaling
0 (T = 1000)	1	0.001	$\times 1000$
	500	0.5	$\times 10$
	1000	1	$\times 1$
	5000	5	$\times 1$
1 (T = 60000)	1	0.000016666	$\times 10000$
	500	0.008333333	$\times 10000$
	1000	0.016666666	$\times 1000$
	5000	0.083333333	$\times 1000$
2 (T = 3600000)	1	0.000000277	$\times 10000$
	500	0.000138888	$\times 10000$
	1000	0.000277777	$\times 10000$
	5000	0.001388888	$\times 10000$

(4) Setting procedure

1. Set "A/D conversion enable/disable setting" to "0: Enable".

🖱️ Project window ⇨ [Intelligent Function Module] ⇨ module name ⇨ [Parameter]

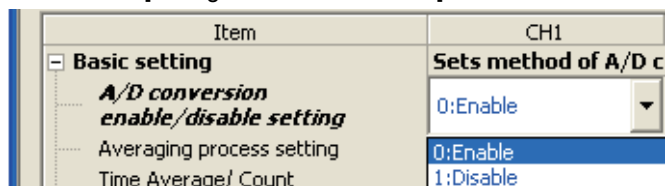

2. Set "Conversion speed setting" to "2: 1ms".

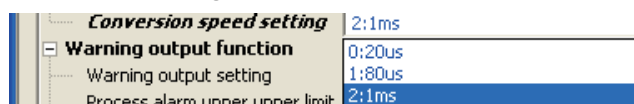

3. Set "Flow amount integration enable/disable setting" to "0: Enabled".

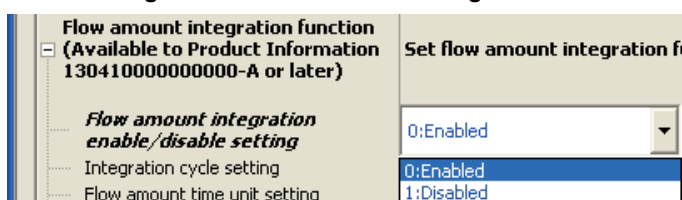

4. Set a value for "Integration cycle setting".

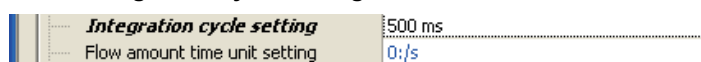

5. Set a value for "Flow amount time unit setting".



6. Set a value for "Unit scaling setting".

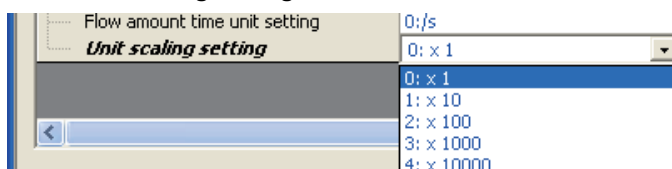

Item	Setting range
Integration cycle setting	1 to 5000ms

Ex. When the flow meter connected to the A/D converter module output the instantaneous flow amount (range: cm³/min) in analog at intervals of 500ms

- "Integration cycle setting": 500ms
- "Flow amount time unit setting": "1: /min"
- "Unit scaling setting": "2: × 100"
- Value in CH□ Scaling value (digital operation value) (Un\G54 to Un\G57) when integral processing is performed: 5000
- Previous amount: 11000 (Maintained amount inside the A/D converter module: 11000.127)

The following formulation shows the integrated flow amount with the above settings.

<i>Flow amount integration function (Available to Product Information 13041000000000-A or later)</i>		Set flow amount integration function
Flow amount integration enable/disable setting		0: Enabled
Integration cycle setting		500 ms
Flow amount time unit setting		1: /min
Unit scaling setting		2: × 100

$$\begin{aligned}
 \text{Integrated flow amount} &= (\text{Instantaneous flow amount} \times \frac{\Delta T}{T} \times \text{Unit scaling}) + \text{Previous amount} \\
 &= (5000 \times \frac{500}{60000} \times 100) + 11000.127 \\
 &= 4166.666 \dots + 11000.127 \\
 &= 15166.7936 \dots
 \end{aligned}$$

"15166" acquired by rounding off the value after the decimal point is stored in CH□ Integrated flow amount (Un\G1332 to Un\G1339).

(5) Flow amount integration temporary stop

The flow amount integration can be stopped temporarily through a program. Flow amount integration function can be temporarily stopped by changing the value of CH□ Flow amount integration temporary stop request (Un\G1356 to Un\G1359) during its operation. CH□ Flow amount integration temporary stop request (Un\G1356 to Un\G1359) operates only when the flow amount integration function is enabled.

(a) Operation procedure to stop the flow amount integration temporarily

1. While the flow amount integration function is operating, change the CH□ Flow amount integration temporary stop request (Un\G1356 to Un\G1359) of the channel to be stopped temporarily No request (0) → Temporary stop request (1).
2. When the rise of No request (0) → Temporary stop request (1) is detected, the flow amount integration function is temporarily stopped, and CH□ Flow amount integration temporary stop flag (Un\G1364 to Un\G1367) of the corresponding channel turns Temporarily stopped (1).

(b) Operation procedure to restart the flow amount integration (to cancel temporary stop)

1. While the flow amount integration function is temporarily stopped, change the CH□ Flow amount integration temporary stop request (Un\G1356 to Un\G1359) of the stopped channel Temporary stop request (1) → No request (0).
2. When the fall of Temporary stop request (1) → No request (0) is detected, the flow amount integration function is restarted, and CH□ Flow amount integration temporary stop flag (Un\G1364 to Un\G1367) of the corresponding channel turns No temporary stop request (0).

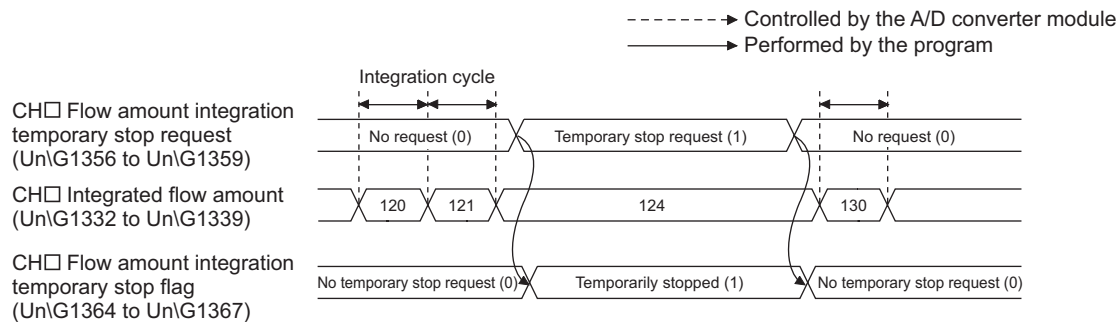

(6) Clearing the integrated flow amount

The integrated flow amount can be cleared in a program. The integrated flow amount can be cleared by changing the value of CH□ Integrated flow amount clear request (UnG1372 to UnG1375) while the flow amount integration function is operating. CH□ Integrated flow amount clear request (UnG1372 to UnG1375) operates only when the flow amount integration function is enabled.

(a) Operation procedure to clear the integrated flow amount

1. While the flow amount integration function is operating, change the CH□ Integrated flow amount clear request (UnG1372 to UnG1375) of the channel to be cleared No request (0) → Clear request (1).
2. When the rise of No request (0) → Clear request (1) is detected, the value of CH□ Integrated flow amount (UnG1332 to UnG1339) of the corresponding channel is cleared to zero.
3. After it is cleared, CH□ Integrated flow amount clear flag (UnG1380 to UnG1383) of the cleared channel turns Cleared (1)
4. Confirm CH□ Integrated flow amount clear flag (UnG1380 to UnG1383) is Cleared (1) and change CH□ Integrated flow amount clear request (UnG1372 to UnG1375) Clear request (1) → No request (0).
5. When the fall of Clear request (1) → No request (0) is detected, CH□ Integrated flow amount clear flag (UnG1380 to UnG1383) turns No request (0).

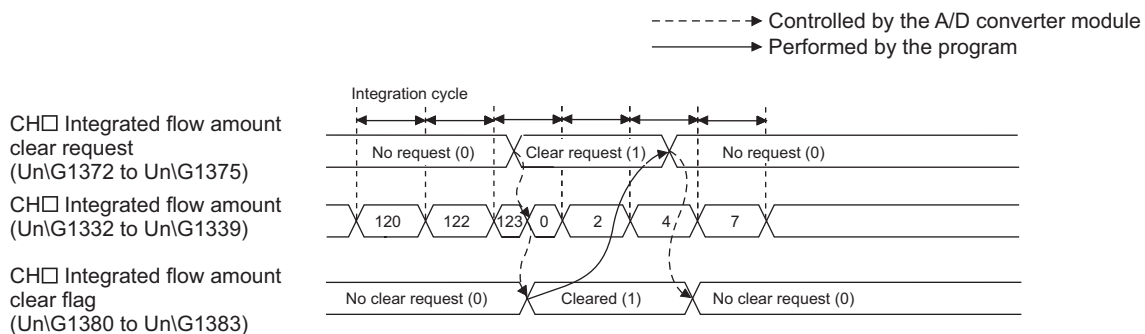

Point

- CH□ Integrated flow amount (UnG1332 to UnG1339) is also cleared to zero in the following case.
 - Set CH□ Flow amount integration enable/disable setting (UnG1300 to UnG1303) to Enable (0) and turn Operating condition setting request (Y9) OFF → ON → OFF.

(7) Change of the integrated flow amount

The following timing chart shows the timings that the integrated flow amount changes.

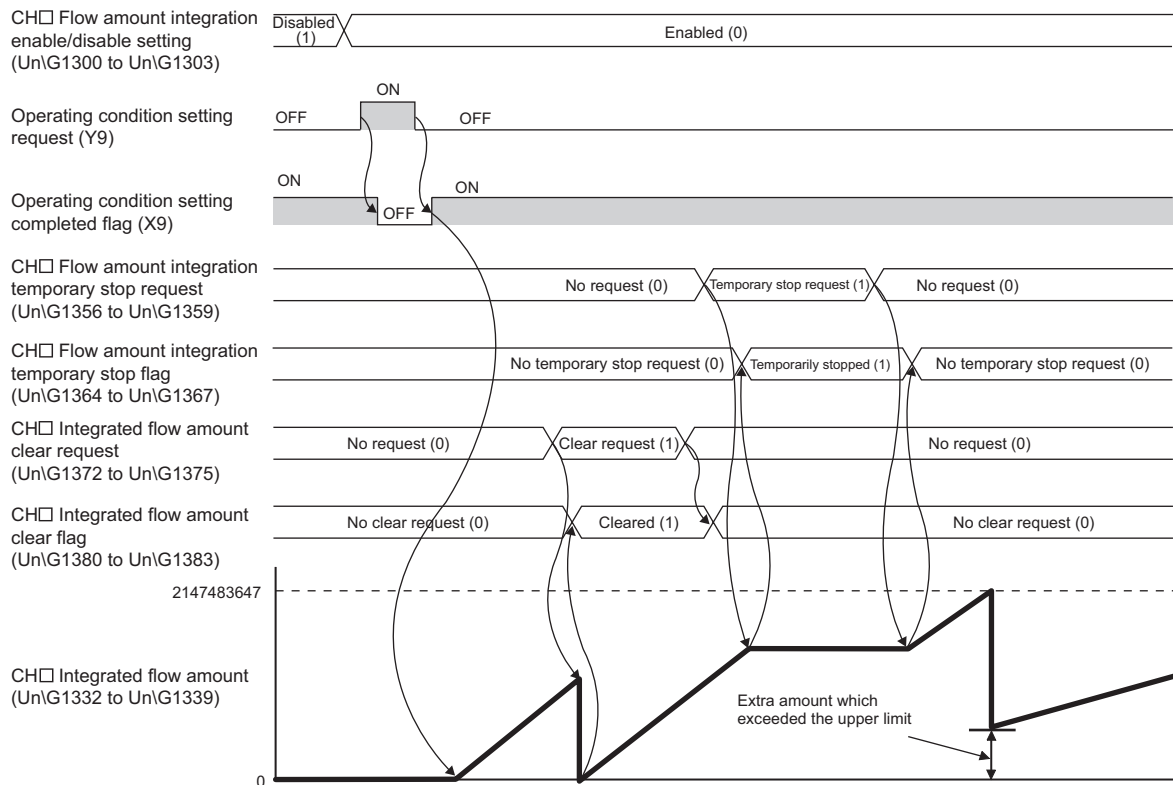

(8) Operation when an input signal error occurs

The integral processing cannot be performed while an input signal error is occurring. When the analog input value returns within the setting range and the A/D conversion is restarted, the integral processing is performed.

(9) Operation when Operating condition setting request (Y9) is turned OFF → ON → OFF

The following processing is performed by changing the settings in the following buffer memory areas and turning Operating condition setting request (Y9) OFF → ON → OFF. The flow amount integration function is performed with the changed settings.

Buffer memory	Processing after changing setting
A/D conversion enable/disable setting (Un\G0)	<ul style="list-style-type: none"> Integration cycles of all channels are changed just by changing 1 channel. The integral processing stops in the channel in which A/D conversion enable/disable setting (Un\G0) changes from Enable (0) to Disable (0). CH□ Integrated flow amount (Un\G1332 to Un\G1339) maintains the value before changing. CH□ Integrated flow amount (Un\G1332 to Un\G1339) of the unchanged channel is cleared to zero. After it is cleared, restart the integral processing with the setting before turning on Operating condition setting request (Y9).
CH□ Time Average/ Count Average/Moving Average (Un\G1 to Un\G4)	<ul style="list-style-type: none"> The integration cycle changes in only the changed channel. CH□ Integrated flow amount (Un\G1332 to Un\G1339) of the changed channel is cleared to zero. CH□ Integrated flow amount (Un\G1332 to Un\G1339) of the unchanged channel is not cleared. The integral processing is continued with the setting before turning on Operating condition setting request (Y9).
Averaging process setting (used to replace Q64AD) (Un\G9)	
Averaging process setting (Un\G24)	
CH□ Integration cycle setting (Un\G1308 to Un\G1311)	
CH□ Flow amount time unit setting (Un\G1316 to Un\G1319)	<ul style="list-style-type: none"> Only in the changed channel, values to be stored in CH□ Integrated flow amount (Un\G1332 to Un\G1339) are changed according to the changed setting of the buffer memory. CH□ Integrated flow amount (Un\G1332 to Un\G1339) of the changed channel is cleared to zero. CH□ Integrated flow amount (Un\G1332 to Un\G1339) of the unchanged channel is not cleared. The integral processing is continued with the setting before turning on Operating condition setting request (Y9).
CH□ Unit scaling setting (Un\G1324 to Un\G1327)	

Point

If Operating condition setting request (Y9) is turned OFF → ON → OFF and one of the following error occurs, the flow amount integration function turns disabled.

- Setting error of CH□ Time Average/ Count Average/Moving Average (Un\G1 to Un\G4) (error code: 20□, error code: 30□, error code: 31□)
- Setting error of Conversion speed setting (Un\G26) (error code: 360□, error code: 210□)
- Setting error of CH□ Flow amount integration enable/disable setting (Un\G1300 to Un\G1303) (error code: 210□)
- Setting error of CH□ Integration cycle setting (Un\G1308 to Un\G1311) (error code: 211□, error code 212□)
- Setting error of CH□ Flow amount time unit setting (Un\G1316 to Un\G1319) (error code: 213□)
- Setting error of CH□ Unit scaling setting (Un\G1324 to Un\G1327) (error code: 214□)

For details on the error contents, refer to the following.

- Error code list (📖 Page 159, Section 11.4)

8.16 Error Log Function

Stores a history of errors and alarms that occurred in the A/D converter module to the buffer memory (Un\G1810 to Un\G1969).

A maximum of 16 errors and alarms can be stored.

(1) Process of the error log function

The error code and the time of error occurrence are stored in the buffer memory address, starting from error history No.1 (start address Un\G1810) and sequentially thereafter. Error occurrence time is stored as follows:

Ex. For error history No. 1

	b15	to	b8	b7	to	b0
Un\G1810	Error code					
Un\G1811	First two digits of the year			Last two digits of the year		
Un\G1812	Month			Day		
Un\G1813	Hour			Minute		
Un\G1814	Second			Day of the week		
Un\G1815 to Un\G1819	System area					

Item	Storage contents	Storage example ^{*1}
First two digits of the year/ Last two digits of the year	Stored in BCD code.	2011 _H
Month/Day		329 _H
Hour/Minute		1035 _H
Second		40 _H
Day of the week	One of the following values is stored for each day of the week in BCD code. <ul style="list-style-type: none"> • Sunday: 0 • Monday: 1 • Tuesday: 2 • Wednesday: 3 • Thursday: 4 • Friday: 5 • Saturday: 6 	2 _H

*1 Those are values when an error occurs at 10:35:40 on Tuesday, March 29th, 2011.

(2) Checking error history

You can check the start address of the latest stored error at Latest address of error history (Un\G1800)

Ex. 1. When the third error occurs:

The third error is stored in error history No.3, and the value "1830" (start address of error history No.3) is stored to Latest address of error history (Un\G1800).

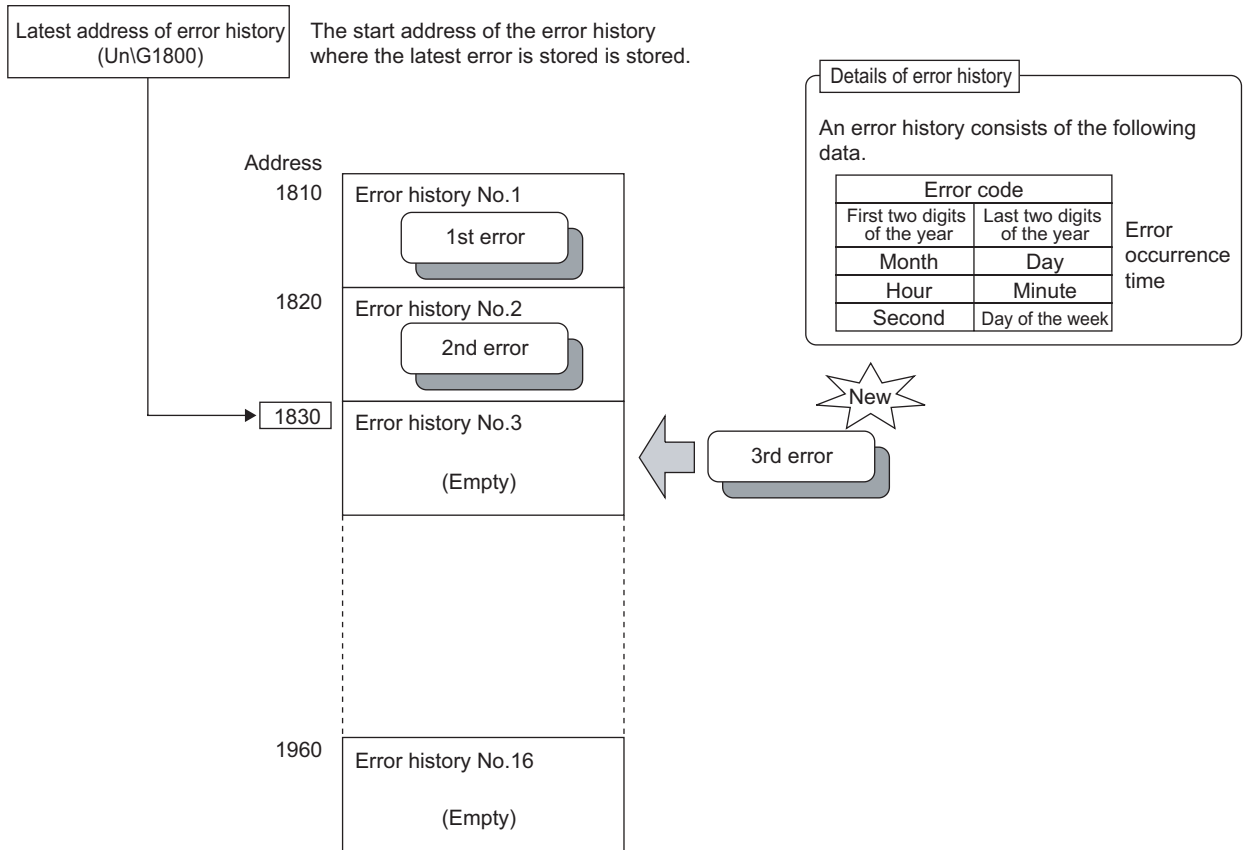

Ex. 2. When a 17th error occurs:

The 17th error is stored in error history No.1, and the value "1810" (start address of error history No.1) gets stored to Latest address of error history (Un\G1800).

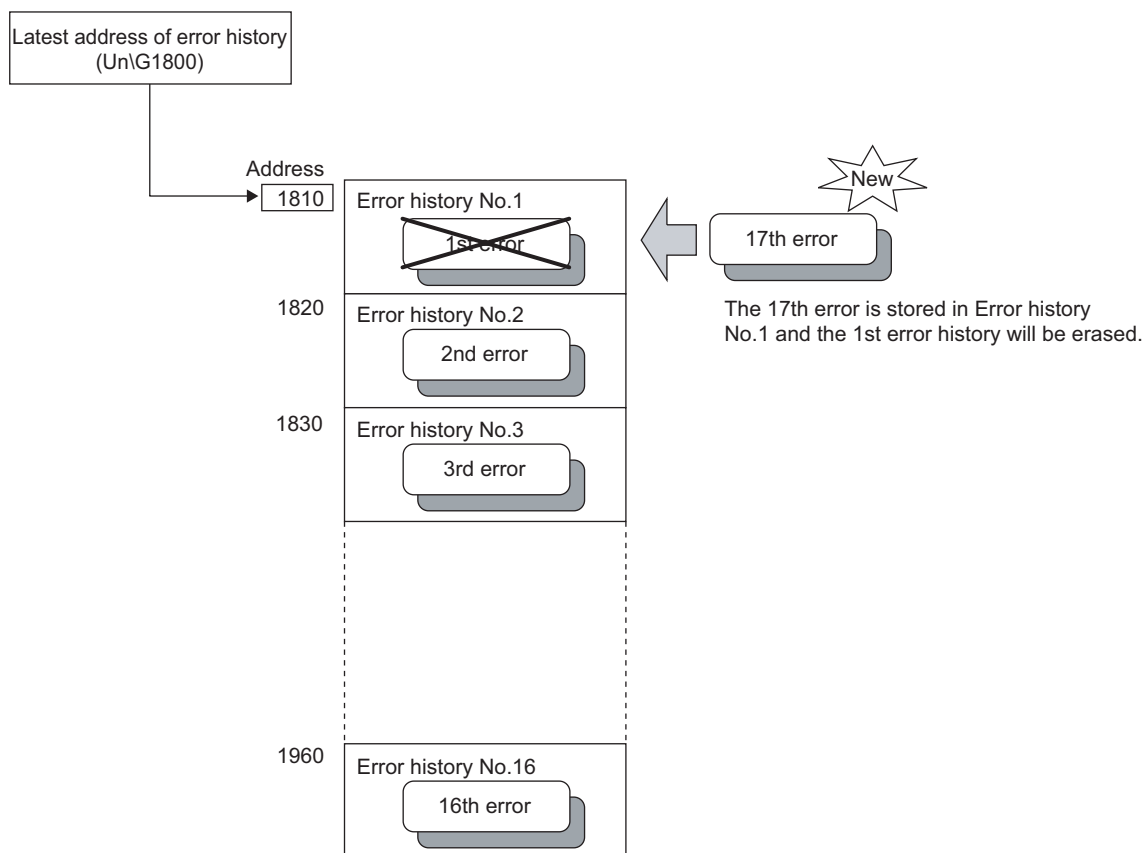

Point

- The same process for errors is used when an alarm occurs.
- Once the error history storage area becomes full, subsequent errors will overwrite the previous errors, starting from error history No.1, and continues sequentially thereafter (Un\G1810 to Un\G1819). (The overwritten history is deleted.)
- The stored error history is cleared when power supply is turned OFF, or when the CPU module is reset.

8.17 Module Error Collection Function

Collects the errors and alarms that occurred in the A/D converter module, into the CPU module or the head module. By holding the module errors in a memory that can hold data in the event of power failure, the errors can be held even after powering off or resetting the CPU module or the head module.

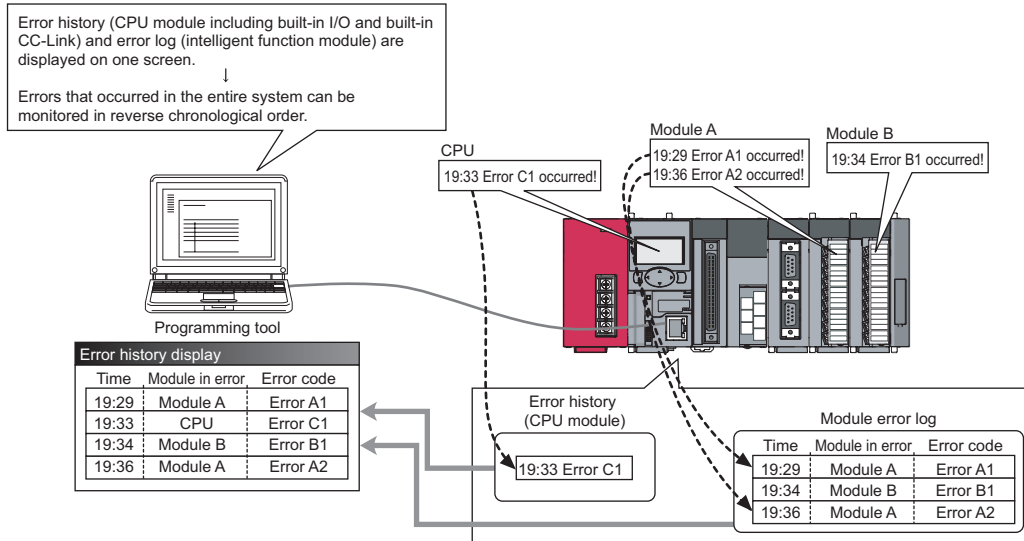

[Example of screen display]

No.	Error Code	Date and Time	Model Name	Start I/O
00125	0070	2009/12/10 17:02:37	L60AD4	0030
00124	0070	2009/12/10 17:00:05	L60AD4	0030
00123	0CE4	2009/12/10 17:00:04	L26CPU-BT	----
00122	05DC	2009/12/10 16:15:50	L26CPU-BT	----
00121	0070	2009/12/10 15:59:30	L60DA4	0030
00120	0070	2009/12/10 15:45:02	L60DA4	0010
00119	05DC	2009/12/10 14:14:38	L26CPU-BT	----
00118	0070	2009/12/10 14:12:03	L60DA4	0010
00117	0CE4	2009/12/10 13:59:54	L26CPU-BT	----
00116	0CE4	2009/12/10 13:35:11	L26CPU-BT	----
00115	05DC	2009/12/10 11:11:45	L26CPU-BT	----
00114	0070	2009/12/10 11:07:05	L60AD4	0010
00113	0CE4	2009/12/10 11:07:04	L26CPU-BT	----
00112	0070	2009/12/10 11:03:49	L60AD4	0010
00111	0CE4	2009/12/10 11:03:48	L26CPU-BT	----
00110	05DC	2009/12/09 16:30:58	L26CPU-BT	----
00109	0070	2009/12/09 16:29:33	L60DA4	0010
00108	0070	2009/12/09 16:29:12	L60DA4	0010
00107	083B	2009/12/09 16:29:11	L26CPU-BT	----



For details on the module error collection function, refer to the following.

MELSEC-L CPU Module User's Manual (Function Explanation, Program Fundamentals)

8.18 Error Clear Function

When an error occurs, you can clear the error from the system monitor.

By clicking the **Error Clear** button in the system monitor, the latest error code stored in Latest error code (Un\G19) is cleared and the ERR. LED is also turned off. The operation is the same as Error clear request (YF) as well as executing error clear from the display unit.

However, error history cannot be cleared.

For instructions on Error clear request (YF) and executing error clear from the display unit, refer to the following.

- Error clear request (YF) (☞ Page 167, Appendix 1)
- Checking/Clearing an Error (☞ Page 138, Section 9.4)

☞ [Diagnostics] ⇨ [System Monitor...] ⇨ Error Module

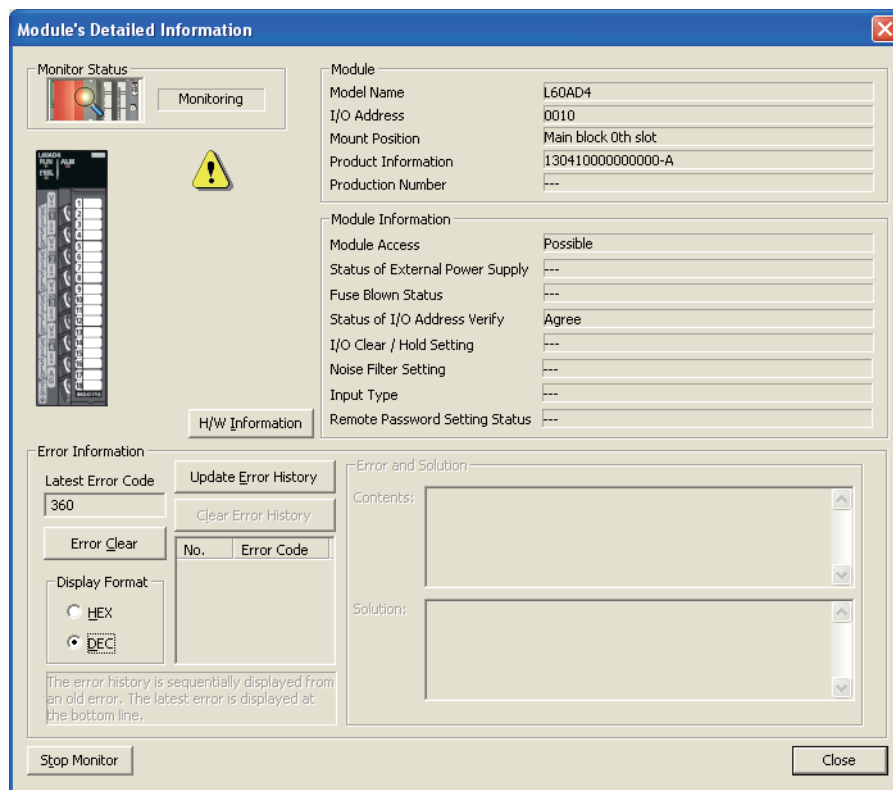

8.19 Saving and Restoring Offset/Gain Values

With the A/D converter module, you can save and restore offset/gain values in the user range setting.

In the event that the A/D converter module fails and need to be replaced, you can restore the offset/gain values of the failed A/D converter module onto a replacement A/D converter module.

In addition, if multiple A/D converter modules are connected on a system, you can apply the offset/gain settings of one of the modules to the other modules.

However, if you save and restore the offset/gain values, the accuracy after the restoration decreases by approximately three times compared to that before the restoration.

Reconfigure the offset/gain as necessary.

(1) Procedure for saving and restoring offset/gain values

(a) To restore offset/gain values onto a new replacement module:

1. Save the offset/gain values.

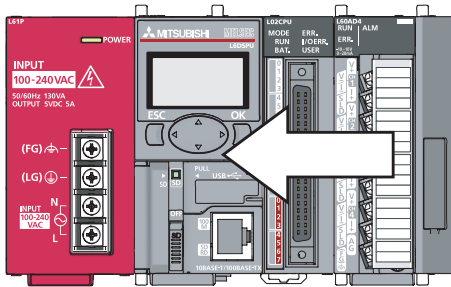

2. Replace A/D converter unit.

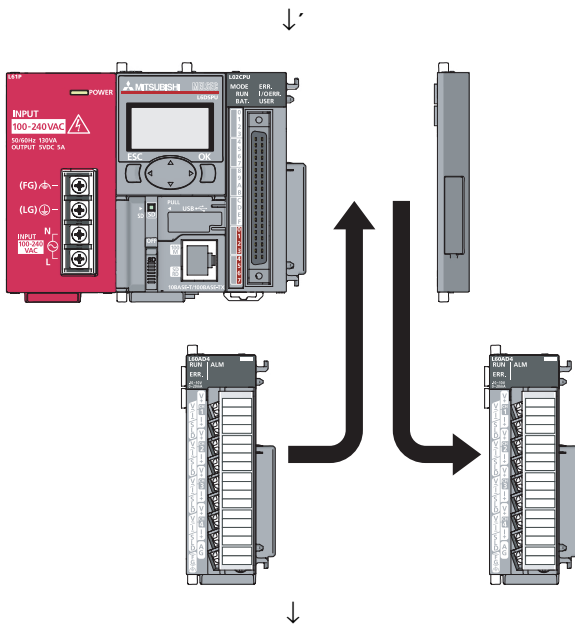

3. Restore the offset/gain values.

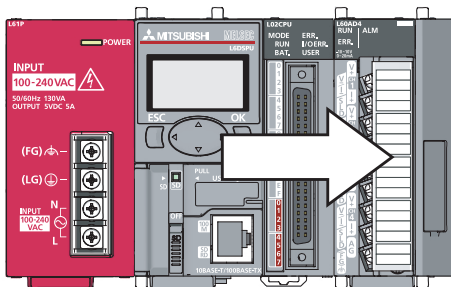

(b) To apply the offset/gain values of one module to the other modules in the same system:

Ex. Here, the offset/gain setting of module No.1 is applied to modules No.2 to No.4.

1. Save the offset/gain values of module No.1.

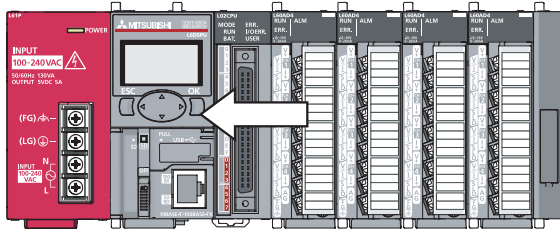

2. Apply the offset/gain values to modules No.2 to No.4.

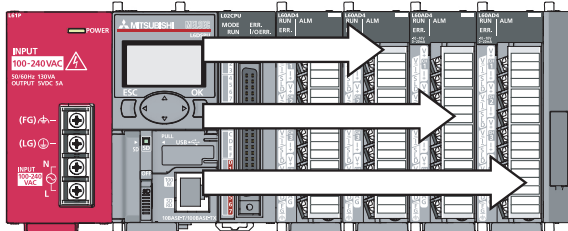

(2) Methods for saving and restoring offset/gain values

There are two methods for saving and restoring offset/gain values.

- Saving and restoring by dedicated instructions
- Saving and restoring by reading from and writing to the buffer memory

(a) Saving and restoring by a dedicated instruction

Use the dedicated instruction G(P).OGLOAD to temporarily save the offset/gain values of the source A/D converter module to the CPU module's internal device, then use G(P).OGSTOR to write to the destination A/D converter module.

You can prevent the saved offset/gain value data from getting deleted, by doing one of the following before replacing the modules:

- Use latch settings for the internal device of the destination module.
- Save the data onto an SD memory card.
To write data: use SP.FWRITE instruction
To read data: use SP.FREAD instruction
- Store the saved data

For use of dedicated instructions, refer to the following.

- Dedicated Instructions (👉 Page 209, Appendix 5)

(b) Saving and restoring by reading from and writing to the buffer memory

In the buffer memory, use Pass data classification setting (Un\G200), CH1 Industrial shipment settings offset value (L)(Un\G202) to CH4 User range settings gain value (H)(Un\G233), and User range write request (YA) to read the offset/gain values from the source A/D converter module, then use the buffer memory again to write to the destination A/D converter module.

The procedure for using the buffer memory is described below.

- To restore offset/gain values onto a new replacement module:

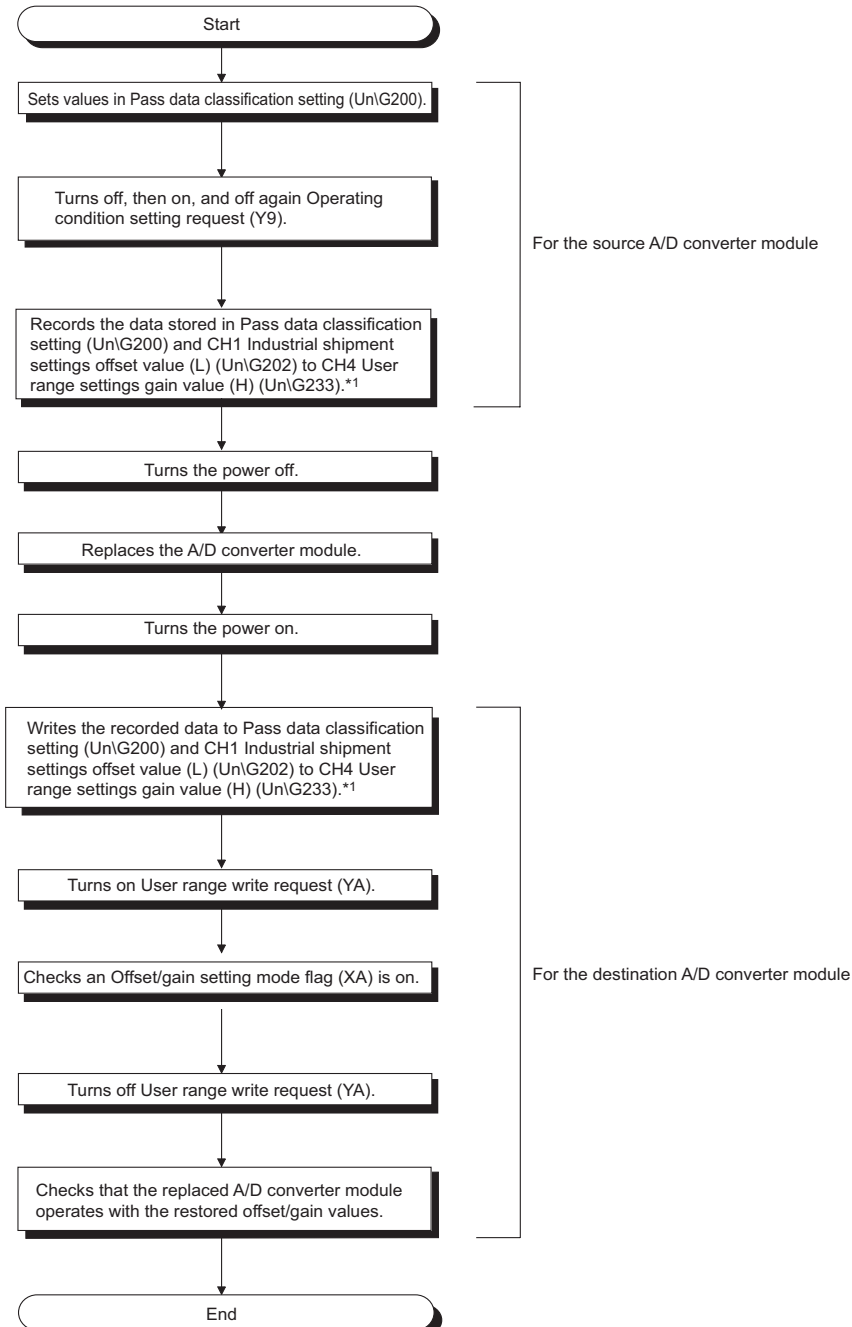

*1 When replacing modules, you can prevent the saved offset/gain value data from getting deleted, by doing one of the following before turning the power off:

- Use latch settings for the internal device of the destination module.
- Save the data onto an SD memory card.
To write data: use SP.FWRITE instruction
To read data: use SP.FREAD instruction
- Store the saved data

- To apply the offset/gain values of one module to the other modules:

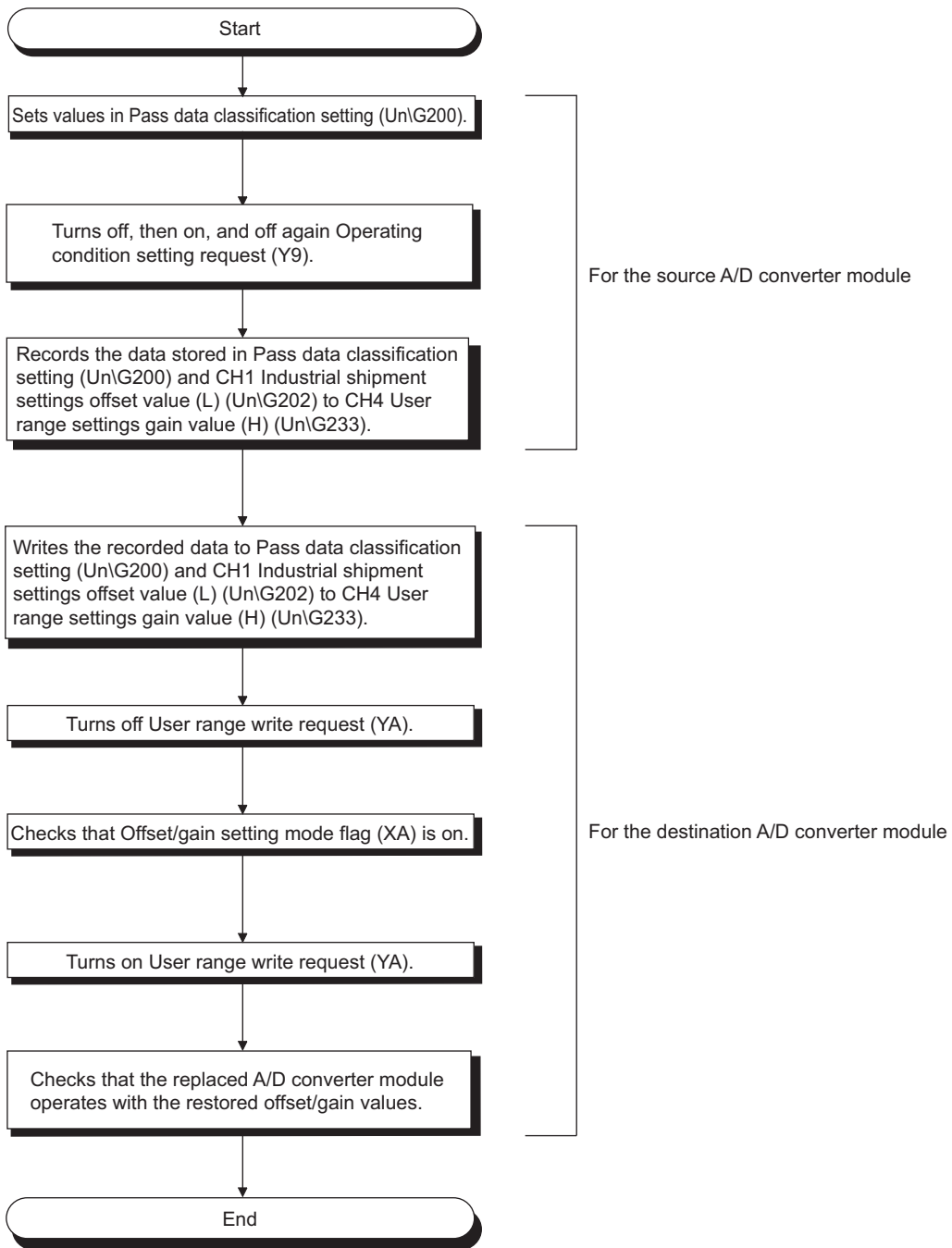

(3) Range reference tables

Below are reference ranges to be used for saving and restoring offset/gain values.

(a) Reference table for CH1 Industrial shipment settings offset value (L)(Un\G202) to CH4 Industrial shipment settings gain value (H)(Un\G217)

The reference values will vary depending on Pass data classification setting (Un\G200) (voltage or current).

Address (decimal)				Description	Pass data classification setting	Reference value (hexadecimal)
CH1	CH2	CH3	CH4			
202, 203	206, 207	210, 211	214, 215	Industrial shipment settings offset value	Voltage	Approx. 00000007 _H
					Current	Approx. 0000000E _H
204, 205	208, 209	212, 213	216, 217	Industrial shipment settings gain value	Voltage	Approx. 00008011 _H
					Current	Approx. 00008018 _H

(b) Reference table for CH1 User range settings offset value (L)(Un\G218) to CH4 User range settings gain value (H)(Un\G233)

Offset/gain value		Reference value (hexadecimal)
Voltage	0V	Approx. 00000007 _H
	1V	Approx. 00000CD4 _H
	5V	Approx. 0000400C _H
	10V	Approx. 00008011 _H
Current	0mA	Approx. 00000007 _H
	4mA* ¹	Approx. 00000CD4 _H
	20mA* ²	Approx. 0000400C _H

*1 This is the value that is stored in user range offset value at the time of shipping.

*2 This is the value that is stored in user range gain value at the time of shipping.

CHAPTER 9 DISPLAY UNIT

This chapter describes the functions of the display unit that can be used with the A/D converter module. For instruction on operating the display unit, or for details on the functions and menu configuration, refer to the following.

 MELSEC-L CPU Module User's Manual (Function Explanation, Program Fundamentals)

9.1 Display Unit

The display unit is an LCD to be attached to the CPU module. By attaching it to the CPU module, you can check the status of the system and change system settings without the software package.

In addition, in the event a problem occurs, you can identify the cause of the problem by displaying the error information.

For details on how to check and clear an error from the display unit, refer to the following.

- Checking/Clearing an Error ( Page 138, Section 9.4)

9.2 Menu Transition

(1) Organization

The diagram below shows how the "MOD MON/TEST" and "MOD SETTINGS" menus are organized.

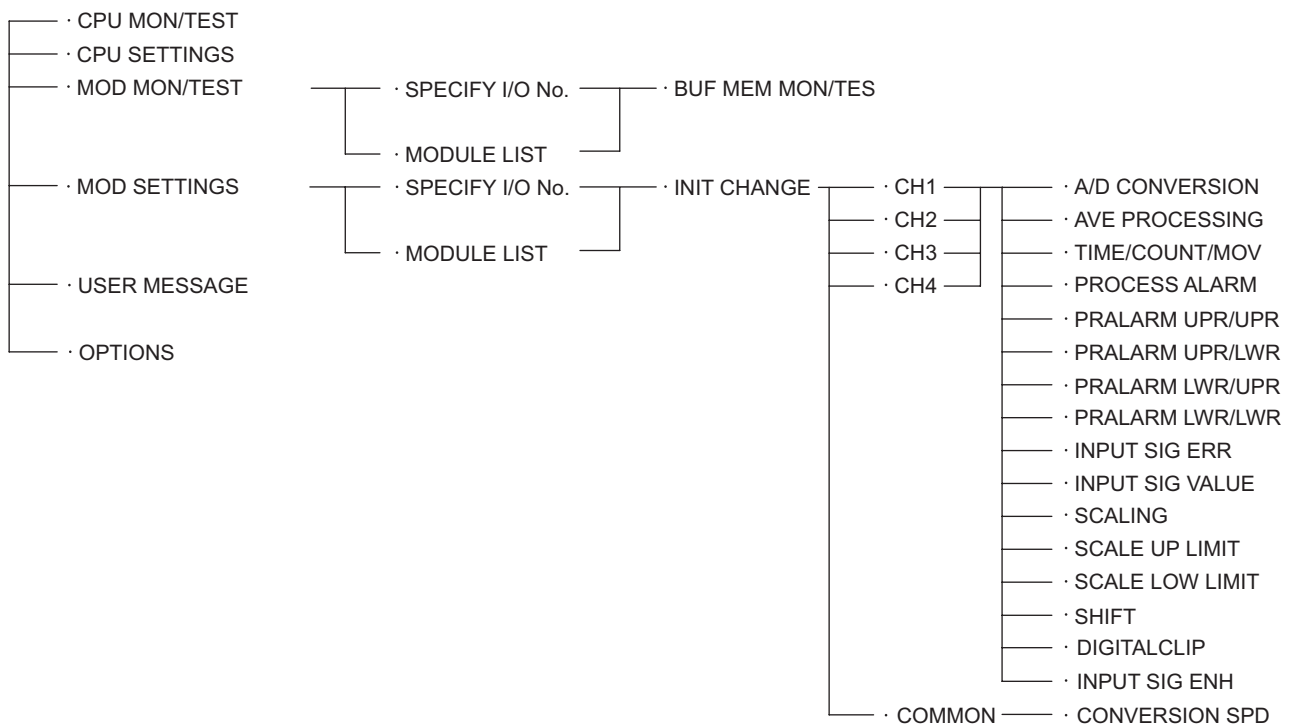

(2) Screen transitions up to the initial setting change screen

The diagram below shows how the screens transition to the initial setting change screen.

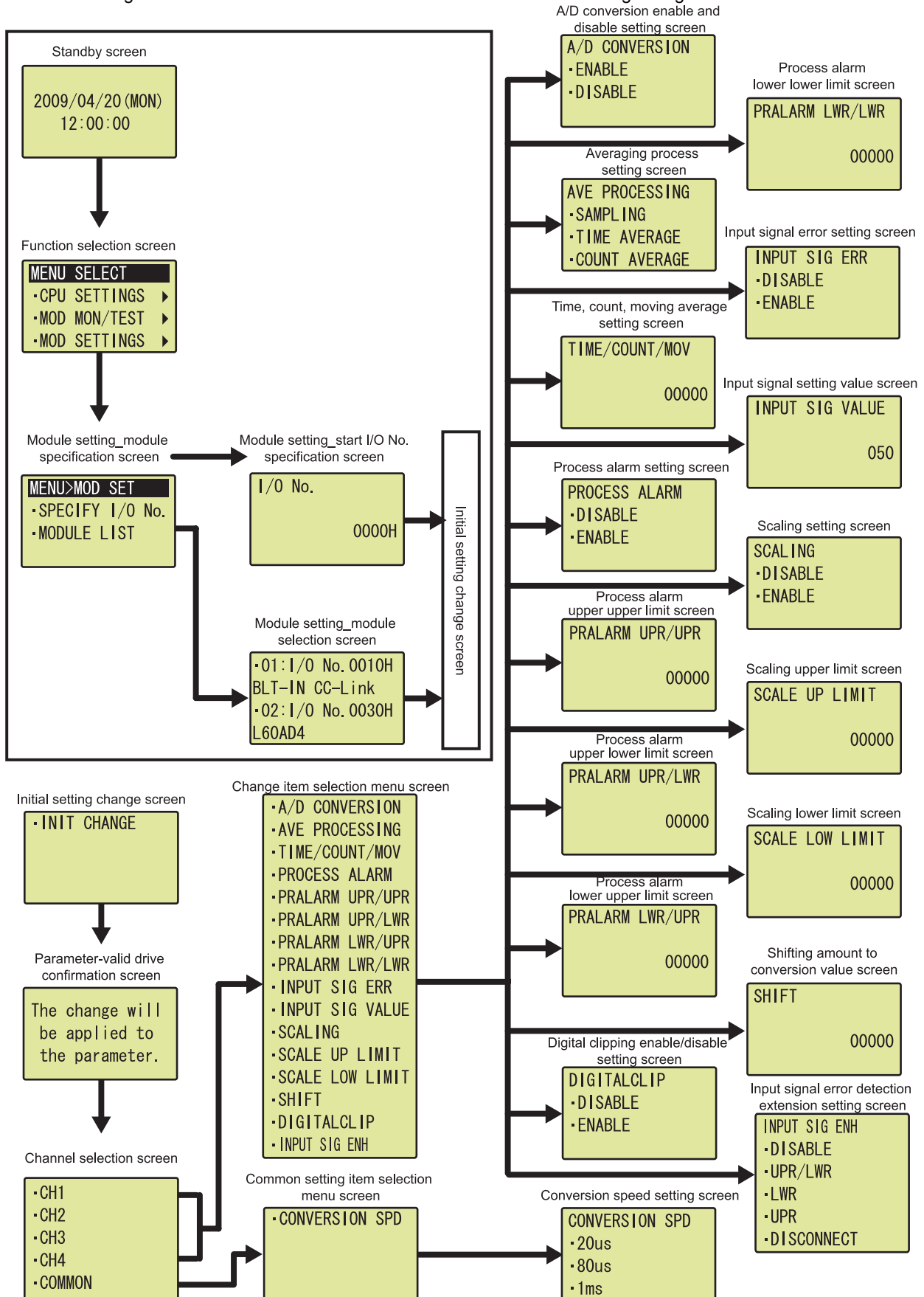

9.3 List of Setting Value Change Screens

The following is a list of setting value change screens.

(1) Displayed in English:

Name		Screen format	Input limits	
Setting item	Screen display		Upper limit	Lower limit
A/D conversion enable/disable setting	A/D CONVERSION	Selection	—	—
Averaging process setting	AVE PROCESSING	Selection	—	—
Time Average/ Count Average/Moving Average	TIME/COUNT/MOV	Numeric	62500	2
Warning output setting	PROCESS ALARM	Selection	—	—
Process alarm upper upper limit value	PRALARM UPR/UPR	Numeric	32767	-32768
Process alarm upper lower limit value	PRALARM UPR/LWR	Numeric	32767	-32768
Process alarm lower upper limit value	PRALARM LWR/UPR	Numeric	32767	-32768
Process alarm lower lower limit value	PRALARM LWR/LWR	Numeric	32767	-32768
Input signal error detection setting	INPUT SIG ERR	Selection	—	—
Input signal error detection setting value	INPUT SIG VALUE	Numeric	250	0
Scaling function	SCALING	Selection	—	—
Scaling upper limit value	SCALE UP LIMIT	Numeric	32000	-32000
Scaling lower limit value	SCALE LOW LIMIT	Numeric	32000	-32000
Shifting amount to conversion value	SHIFT	Numeric	32767	-32768
Digital clipping function	DIGITALCLIP	Selection	—	—
Input signal error detection enhancing setting value	INPUT SIG ENH	Selection	—	—
Conversion speed setting	CONVERSION SPD	Selection	—	—

(2) A/D conversion enable/disable setting

Select "ENABLE" or "DISABLE" in the "A/D CONVERSION" screen.

"A/D CONVERSION" screen

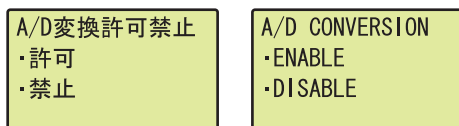

1. Use the ▲ and ▼ buttons to select "ENABLE" or "DISABLE", and then confirm with the button.

(3) Averaging process setting

In the "AVE PROCESSING" screen, select whether to perform sampling processing or averaging processing (time average, count average, moving average).

"AVE PROCESSING" screen



"TIME/COUNT/MOV" screen

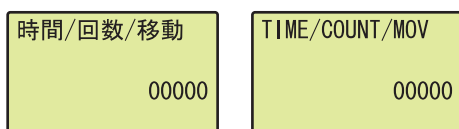

1. Use the ▲ and ▼ buttons to select "SAMPLING", "TIME AVERAGE", "COUNT AVERAGE", or "MOVING AVERAGE", and then confirm with the . (If you selected any item other than "SAMPLING", proceed to step 2.)
2. Move the cursor using the ◀ and ▶ buttons, then increment or decrement the value at the cursor, using the ▲ and ▼ buttons, respectively. Confirm with the button.

Table of input items

Input item	Conversion speed	Input range	
		Input upper limit	Input lower limit
TIME	20μs	1500	2
	80μs/1ms	5000	2
COUNT	20μs/80μs/1ms	62500	4
MOV	20μs/80μs/1ms	1000	2

Point

The display unit allows you to input between 2 to 62500 for any type of averaging processing, however, if the value is outside the setting range of the averaging processing that you selected, an error will occur on the A/D converter module side.

(4) Warning output setting

Select "DISABLE" or "ENABLE" in the "PROCESS ALARM" screen.

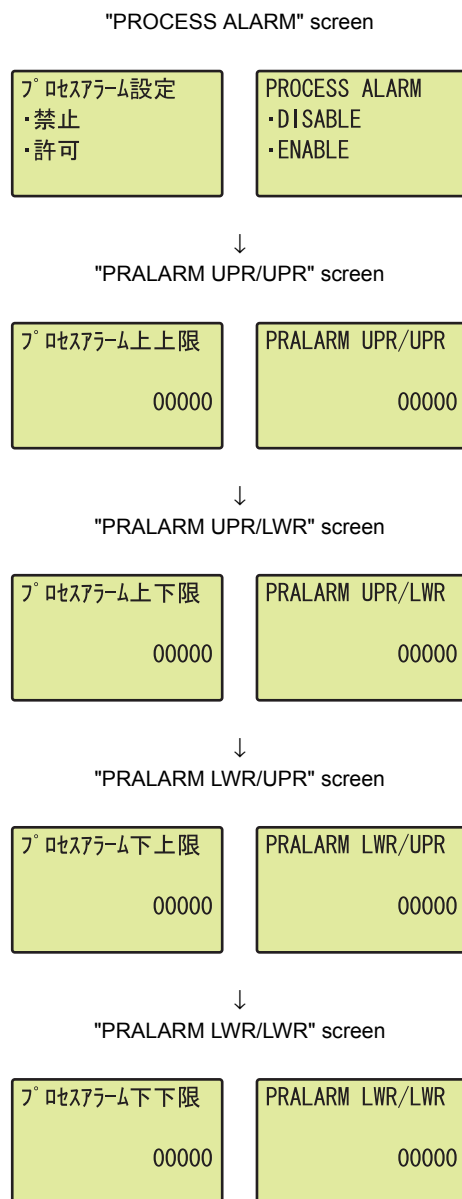

1. Use the ▲ and ▼ buttons to select "DISABLE" or "ENABLE", and then confirm with the **OK** button. (If you selected "ENABLE", follow the rest of the procedure.)
2. Move the cursor using the ◀ and ▶ buttons, then increment or decrement the value at the cursor, using the ▲ and ▼ buttons, respectively. Confirm with the **OK** button.
3. Move the cursor using the ◀ and ▶ buttons, then increment or decrement the value at the cursor, using the ▲ and ▼ buttons, respectively. Confirm with the **OK** button.
4. Move the cursor using the ◀ and ▶ buttons, then increment or decrement the value at the cursor, using the ▲ and ▼ buttons, respectively. Confirm with the **OK** button.
5. Move the cursor using the ◀ and ▶ buttons, then increment or decrement the value at the cursor, using the ▲ and ▼ buttons, respectively. Confirm with the **OK** button.

Table of input items

Input item	Input range	
	Input upper limit	Input lower limit
PRALARM UPR/UPR	32767	-32768
PRALARM UPR/LWR		
PRALARM LWR/UPR		
PRALARM LWR/LWR		

(5) Input signal error detection setting

Select "DISABLE" or "ENABLE" in the "INPUT SIG ERR" screen.

"INPUT SIG ERR" screen

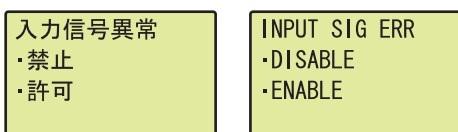

"INPUT SIG VALUE" screen



1. Use the ▲ and ▼ buttons to select "DISABLE" or "ENABLE", and then confirm with the  button. (If you selected "ENABLE", proceed to step 2.)

2. Move the cursor using the ◀ and ▶ buttons, then increment or decrement the value at the cursor, using the ▲ and ▼ buttons, respectively. Confirm with the  button.

Table of input items

Input item	Input range	
	Input upper limit	Input lower limit
INPUT SIG VALUE	250	0

(6) Scaling setting

Select "DISABLE" or "ENABLE" in the "SCALING" screen.

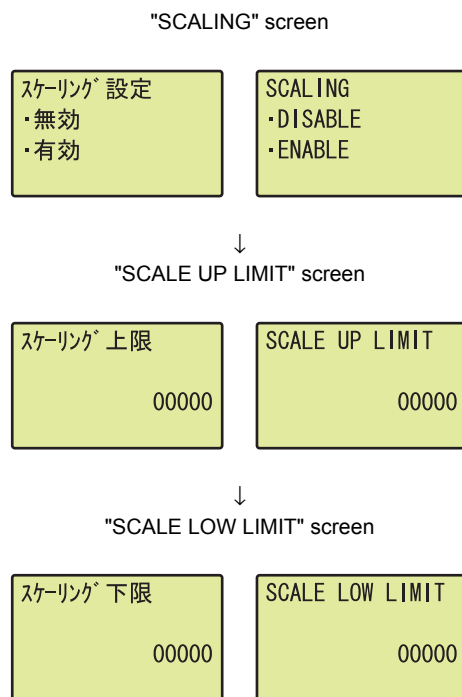

1. Use the ▲ and ▼ buttons to select "DISABLE" or "ENABLE", and then confirm with the **OK** button. (If you selected "ENABLE", follow the rest of the procedure.)
2. Move the cursor using the ◀ and ▶ buttons, then increment or decrement the value at the cursor, using the ▲ and ▼ buttons, respectively. Confirm with the **OK** button.
3. Move the cursor using the ◀ and ▶ buttons, then increment or decrement the value at the cursor, using the ▲ and ▼ buttons, respectively. Confirm with the **OK** button.

Table of input items

Input item	Input range	
	Input upper limit	Input lower limit
SCALE UP LIMIT	32000	-32000
SCALE LOW LIMIT		

(7) Shifting amount to conversion value

Set the shifting amount to conversion value in the "SHIFT" screen.

"SHIFT" screen

変換値シフト量 00000	SHIFT 00000
------------------	----------------

1. Move the cursor using the ◀ and ▶ buttons, then increment or decrement the value at the cursor, using the ▲ and ▼ buttons, respectively. Confirm with the  button.

Input item lists

Input item	Input range	
	Input upper limit	Input lower limit
SHIFT	32767	-32768

Point

The "Shifting amount to conversion value" is reflected to the scaling value regardless of turning Operating condition setting request (Y9) OFF → ON → OFF. However, when the "Shifting amount to conversion value" is set in a display unit, it is not reflected just after setting. As well as other functions of display unit, turn the CPU module STOP → RUN → STOP → RUN to reflect the setting value.

(8) Digital clipping enable/disable setting

Select "DISABLE" or "ENABLE" in the "DIGITALCLIP" screen.

"DIGITALCLIP" screen

デジタルクリップ ・無効 ・有効	DIGITALCLIP ・DISABLE ・ENABLE
------------------------	------------------------------------

1. Use the ▲ and ▼ buttons to select "DISABLE" or "ENABLE", and then confirm with the  button.

(9) Input signal error detection extension setting

Select a detection method in the "INPUT SIG ENH" screen.

"INPUT SIG ENH" screen

入力信号拡張 ・無効 ・上下限検出 ・下限検出	INPUT SIG ENH ・DISABLE ・UPR/LWR ・LWR
----------------------------------	---

1. Use the ▲ and ▼ buttons to select "DISABLE" or "ENABLE" from the following detection methods, and then confirm with the  button.
 - DISABLE
 - UPR/LWR
 - LWR
 - UPR
 - DISCONNECT

Point

When "INPUT SIG ENH" is set to other than "DISABLE", setting "INPUT SIG ERR" to "ENABLE" is not necessary. The setting of "INPUT SIG ERR" will be ignored.

(10) Conversion speed setting

In the "CONVERSION SPD" screen, specify the conversion speed of the A/D conversion processing.

"CONVERSION SPD" screen

変換速度設定 • 20 μ s • 80 μ s • 1ms	CONVERSION SPD • 20us • 80us • 1ms
---	---

1. Use the ▲ and ▼ buttons to select the conversion speed, and then confirm with the  button.

9.4 Checking and Clearing Errors

You can check the errors that occurred in the A/D converter module, from the display unit. In addition, you can also clear an error during its occurrence.

(1) Checking the error

You can check the error that occurred in the A/D converter module, by specifying Latest error code (Un\G19) from "buffer memory monitor/test".

Ex. When an error occurs in the A/D converter module with a start I/O number of 1

"Buffer memory monitor/test" screen

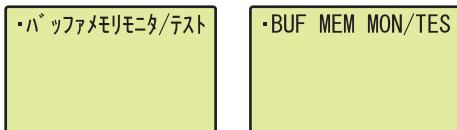

"Buffer memory address input format selection" screen

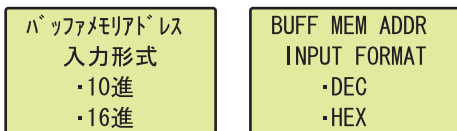

"Buffer memory address setting" screen

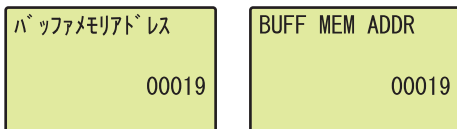

"Buffer memory monitor" screen

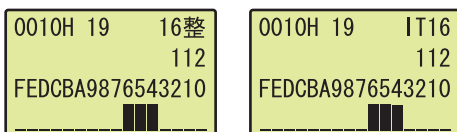

1. Press the **OK** button.

2. Use the **▲** and **▼** buttons to select "DEC" for the input format of the buffer memory address, and then confirm with the **OK** button.

3. Move the cursor using the **◀** and **▶** buttons, then increment or decrement the value at the cursor, using the **▲** and **▼** buttons, and set the value to 19. Confirm with the **OK** button.

4. You can check the error that occurred, in the "Buffer memory monitor" screen.

(2) Clearing errors

You can clear an error by eliminating the cause of the error, and turning Error clear request (YF) OFF → ON → OFF from "Device Monitor/Test".

Ex. When an error occurs in the A/D converter module with a start I/O number of 1

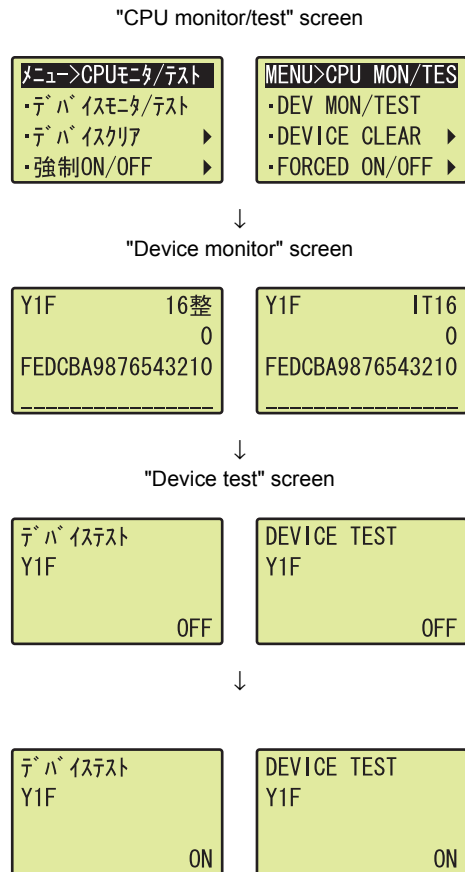

1. Use the ▲ and ▼ buttons to select "DEV MON/TEST", and then confirm with the **[OK]** button.

2. Set the device to Y and press the **[OK]** button.

3. Use the ▲ and ▼ buttons to set the device to Y1F, and then confirm with the **[OK]** button.

4. Use the ▲ and ▼ buttons to switch ON/OFF. Press the **[OK]** button to set the value at the device test setting.

CHAPTER 10 PROGRAMMING

This chapter describes the procedure for programming and the basic program of the A/D converter module.

10.1 Procedure for Programming

Create a program to execute A/D conversion, according to the following procedure.

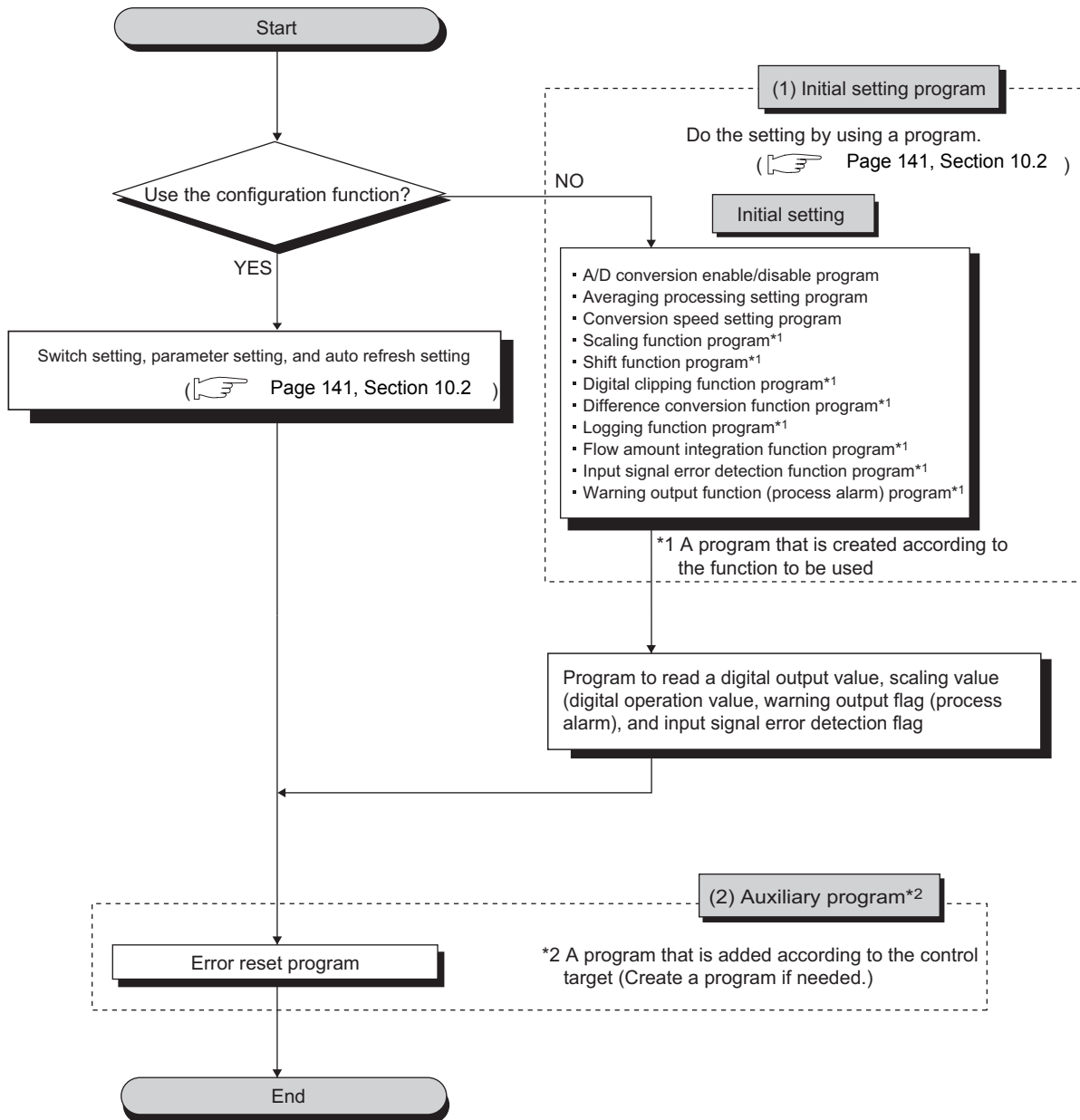

10.2 When Using the Module in a Standard System Configuration

The following shows program examples for the system configuration and usage conditions of the A/D converter module.

(1) System configuration

The following shows an example of the system configuration when using the module in a standard system configuration.

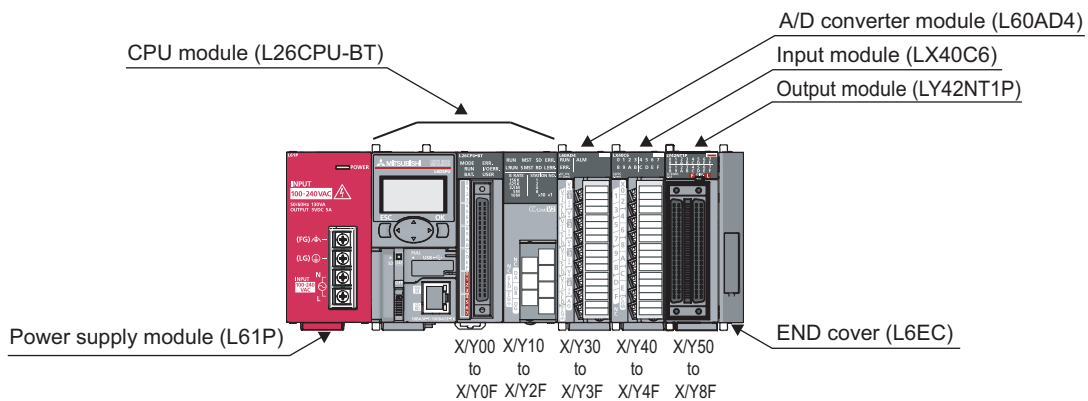

Point

For configuring the same I/O assignment as the system above, when using the L02CPU, set the I/O assignment of the A/D converter module within X/Y30 to 3F. Also, set the I/O assignment of the LX40C6 within X/Y40 to 4F, and the same of the LY42NT1P, within X/Y50 to 8F.

(2) Programming condition

This program reads digital output values enabled for A/D conversion at CH1 to CH3 in the A/D converter module.

CH1 executes sampling processing, CH2 executes averaging processing every 50 times and CH3 executes A/D conversion every 10 moving averages. If an error occurs in the module, an error code is displayed in BCD notation.

(3) Switch setting

Set the input range and the operation mode.

Project window ⇨ [Intelligent Function Module] ⇨ [L60AD4] ⇨ [Switch Setting]

Switch Setting 0030:L60AD4

Input Range Setting

CH	Input range
CH1	4 to 20mA
CH2	4 to 20mA
CH3	4 to 20mA
CH4	4 to 20mA

Drive Mode Setting

Normal (A/D Converter Processing) Mode

* The following are available for the Input Range Setting,
for product information 13041000000000-A or later.
- 4 to 20mA (extension mode)
- 1 to 5V (extension mode)

* This dialog setting is linked to the Switch Setting of the PLC parameter.
Default value will be shown in the dialog
if the Switch Setting of the PLC parameter contains an out-of-range value.

OK Cancel

(4) Initial setting description**(a) Channel setting**

Item	Description			
	CH1	CH2	CH3	CH4
A/D conversion enable/disable setting	Enable	Enable	Enable	Disable
Averaging process setting	Sampling processing	Count average	Moving average	Sampling processing
Time Average/ Count Average/ Moving Average	0	50 times	10 times	0
Conversion speed setting	20 μ s			
Warning output setting	Disable	Enable	Disable	Disable
Process alarm upper upper limit value	0	20000	0	0
Process alarm upper lower limit value	0	18000	0	0
Process alarm lower upper limit value	0	3000	0	0
Process alarm lower lower limit value	0	0	0	0
Input signal error detection setting	Enable	Disable	Disable	Disable
Input signal error detection setting value	10.0%	5.0%	5.0%	5.0%
Input signal error detection extension setting	Disable	Disable	Disable	Disable
Scaling enable/disable setting	Disable	Disable	Enable	Disable
Scaling upper limit value	0	0	32000	0
Scaling lower limit value	0	0	0	0
Shifting amount to conversion value	0	0	10000	0
Digital clipping function enable/disable setting	Disable	Disable	Enable	Disable

(b) Device for user

Device	Description
D1(D11)	CH1 Digital output value
D2(D12)	CH2 Digital output value
D8	Input signal error detection flag
D10	Error code
D18	Warning output flag
D28(D13)	CH3 Scaling value (digital operation value)
M0	CH1 A/D conversion completed flag
M1	CH2 A/D conversion completed flag
M2	CH3 A/D conversion completed flag
M20 to 27	Warning output flag
M50 to 53	Input signal error detection flag
M100	Module READY checking flag
X40	Digital output value read command input signal
X43	Input signal error detection reset signal
X44	Error reset signal
Y50 to 5F	Error code notation (BCD 3 digits)

LX40C6 (X40 to 4F)

LY42NT1P (Y50 to 5F)

(5) Program example when using the parameter of intelligent function module

(a) Parameter setting

Set the contents of initial settings in the parameter.

Project window ⇒ [Intelligent Function Module] ⇒ [L60AD4] ⇒ [Parameter]

The screenshot shows the 'Parameter' configuration window for the L60AD4 module. The window title is '0030:L60AD4[]-Parameter'. A 'Display Filter' dropdown is set to 'Display All'. The main area is a table with columns for 'Item', 'CH1', 'CH2', 'CH3', and 'CH4'. The settings are organized into several sections:

- Basic setting**: Includes 'Sets method of A/D conversion control.' with options like '0:Enable', '0:Sampling Processing', '2:Count Average', '3:Moving Average', and '0:Sampling Processing'.
- Warning output function**: Includes 'Sets for warnings on A/D conversion.' with options like '1:Disable', '0:Enable', and '1:Disable'.
- Input signal error detection**: Includes 'Sets for input signals on A/D conversion.' with options like '0:Enable', '1:Disable', and '5.0 %'.
- Input signal error detection enhancing**: Includes 'Set input signal error detection (enhancing) when A/D conversion is executed.' with options like '0:Disable'.
- Scaling function**: Includes 'Sets for scaling on A/D conversion.' with options like '1:Disable', '0:Enable', and '32000'.
- Shift function**: Includes 'Set shift function when A/D conversion is executed.' with options like '0' and '10000'.
- Digital clipping function**: Includes 'Set digital clipping function when A/D conversion is executed.' with options like '1:Disable', '0:Enable', and '1:Disable'.

At the bottom of the window, there is a summary text: 'Sets method of A/D conversion control.'

(b) Auto refresh setting

Project window ⇒ [Intelligent Function Module] ⇒ [L60AD4] ⇒ [Auto_Refresh]

The screenshot shows the 'Auto_Refresh' configuration window for the L60AD4 module. The window title is '0030:L60AD4[]-Auto_Refresh'. A 'Display Filter' dropdown is set to 'Display All'. The main area is a table with columns for 'Item', 'CH1', 'CH2', 'CH3', and 'CH4'. The settings are organized into sections:

- Transfer to PLC**: Includes 'Transfers buffer memory data to the specified device.' with options like 'D1', 'D2', 'D28', 'D18', 'D8', and 'D10'.

At the bottom of the window, there is a summary text: 'Transfers buffer memory data to the specified device.'

(c) Writing parameter of intelligent function module

Write the set parameter to the CPU module and reset the CPU module, or then off and then on the programmable controller power supply.

 [Online] ⇨ [Write to PLC...]

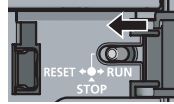

or Power OFF → ON

(d) Program example

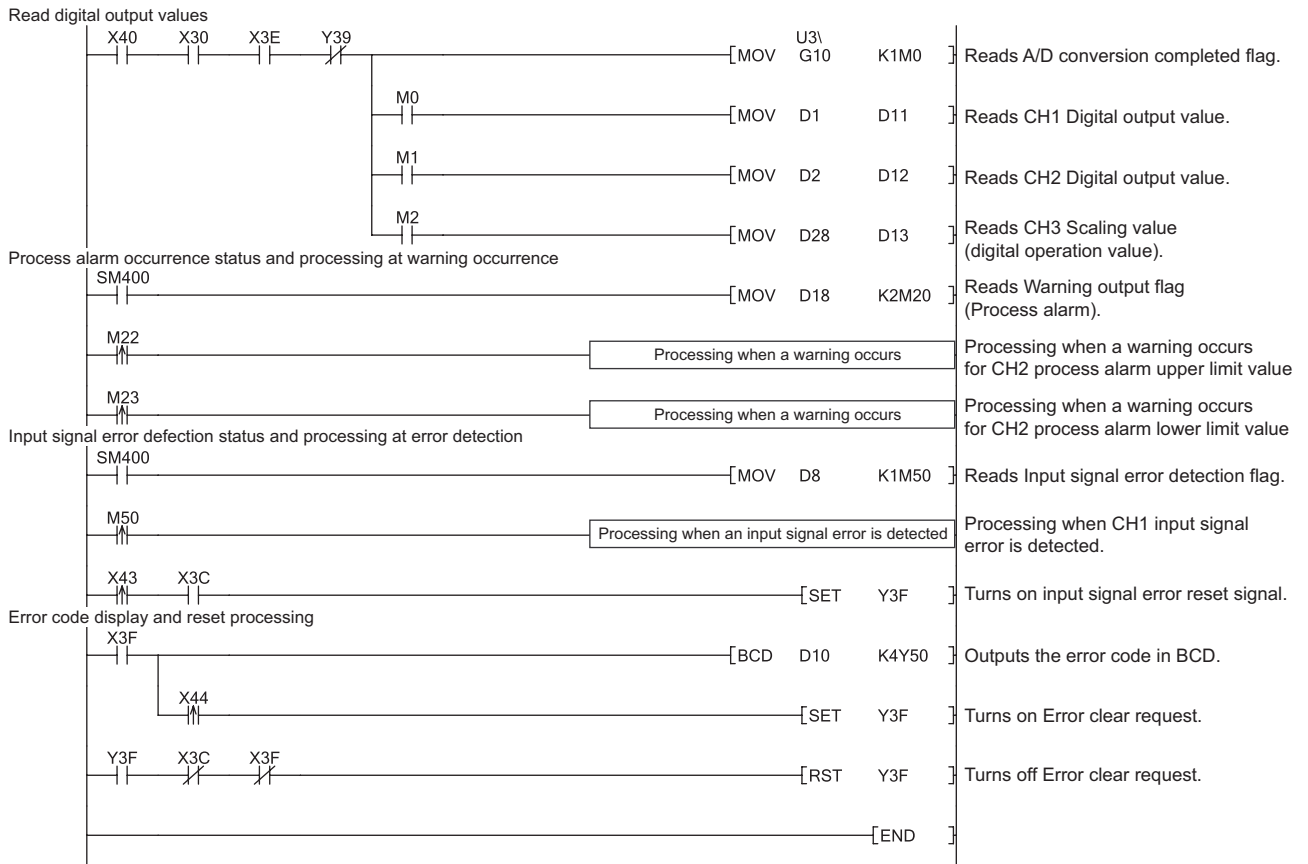

10.2 When Using the Module in a Standard System Configuration

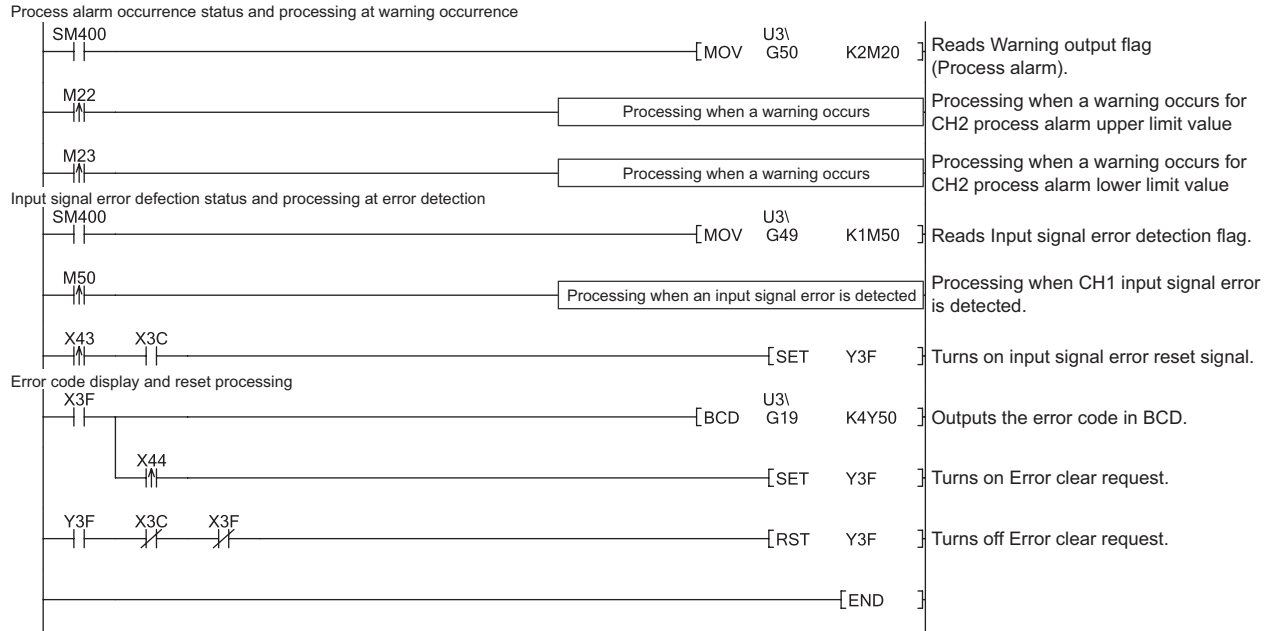

10.3 When A/D Converter Module is Connected to Head Module

This section describes the system configuration of A/D converter module and a program example of operation condition.

(1) System configuration

The following describes the system configuration examples when the A/D converter module is mounted to a head module.

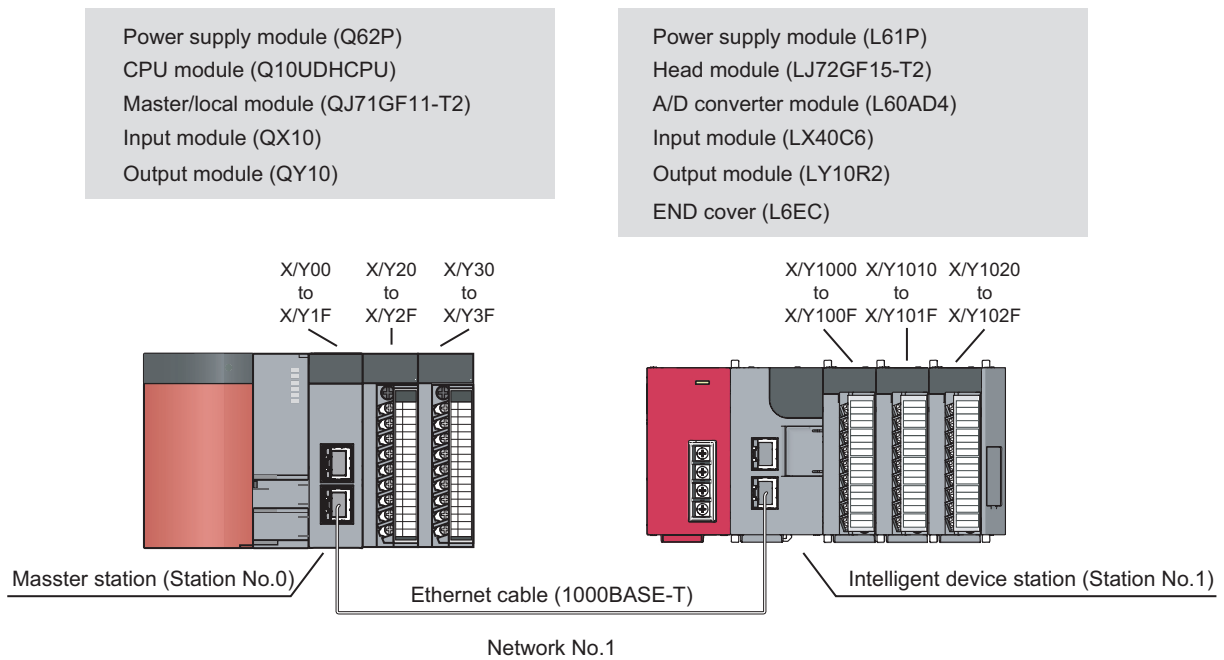

(2) Programming conditions

This program reads digital output values enabled for A/D conversion at CH1 to CH3 in the A/D converter module. CH1 executes sampling processing, CH2 executes averaging processing every 50 times and CH3 executes A/D conversion every 10 moving averages. If an error occurs in the module, an error code is displayed in BCD notation.

(3) Description of initial settings

Item	Description			
	CH1	CH2	CH3	CH4
A/D conversion enable/disable setting	Enable	Enable	Enable	Disable
Averaging process setting	Sampling processing	Count average	Moving average	Sampling processing
Time Average/Count Average/Moving Average	0	50 times	10 times	0
Conversion speed setting	20 μ s			
Warning output setting	Disable	Enable	Disable	Disable
Process alarm upper upper limit value	0	20000	0	0
Process alarm upper lower limit value	0	18000	0	0
Process alarm lower upper limit value	0	3000	0	0
Process alarm lower lower limit value	0	0	0	0
Input signal error detection setting	Enable	Disable	Disable	Disable
Input signal error detection setting value	10.0%	5.0%	5.0%	5.0%
Input signal error detection extension setting	Disable	Disable	Disable	Disable
Scaling enable/disable setting	Disable	Disable	Enable	Disable
Scaling upper limit value	0	0	32000	0
Scaling lower limit value	0	0	0	0
Shifting amount to conversion value	0	0	10000	0
Digital clipping function enable/disable setting	Disable	Disable	Enable	Disable

(4) Devices used by a user

Device	Description	
W1000	A/D conversion completed flag	
W1001	CH1 Digital output value	
W1002	CH2 Digital output value	
W1008	Input signal error detection flag	
W1010	Latest error code	
W1018	Warning output flag (Process alarm)	
W1028	CH3 Scaling value (digital operation value)	
M0	CH1 A/D conversion completed flag	
M1	CH2 A/D conversion completed flag	
M2	CH3 A/D conversion completed flag	
M20 to M27	Warning output flag (Process alarm)	
M50 to M53	Input signal error detection flag	
X20	Digital output value read command input signal	QX10 (X20 to X2F)
X23	Input signal error detection reset signal	
X24	Error reset signal	
Y30 to Y3F	Error code display (BCD 4 digits)	QY10 (Y30 to Y3F)
SB49	Data link status (own station)	
SWB0.0	Data link status (each station) (station number 1)	
N0	Nesting (station number 1)	
M100	Flag for meeting the communication condition (station number 1)	

3. Display the Network Configuration Setting screen and configure the setting as follows.

Project window ⇨ [Parameter] ⇨ [Network Parameter] ⇨ [Ethernet/CC IE/MELSECNET] ⇨  button

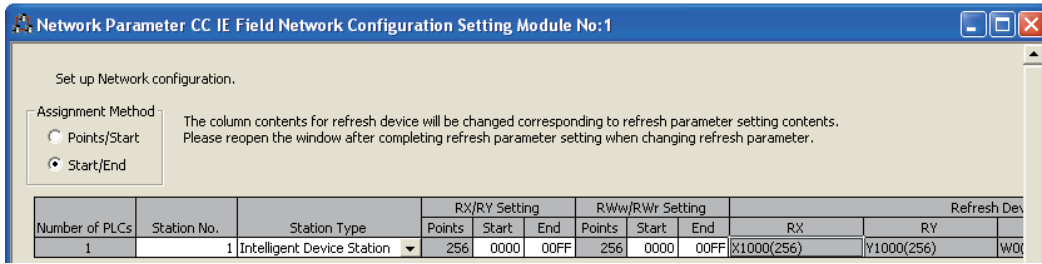

4. Display the Auto Refresh setting screen for the A/D converter module (L60AD4) and configure the setting as follows.

Project window ⇨ [Parameter] ⇨ [Network Parameter] ⇨ [Ethernet/CC IE/MELSECNET] ⇨  button

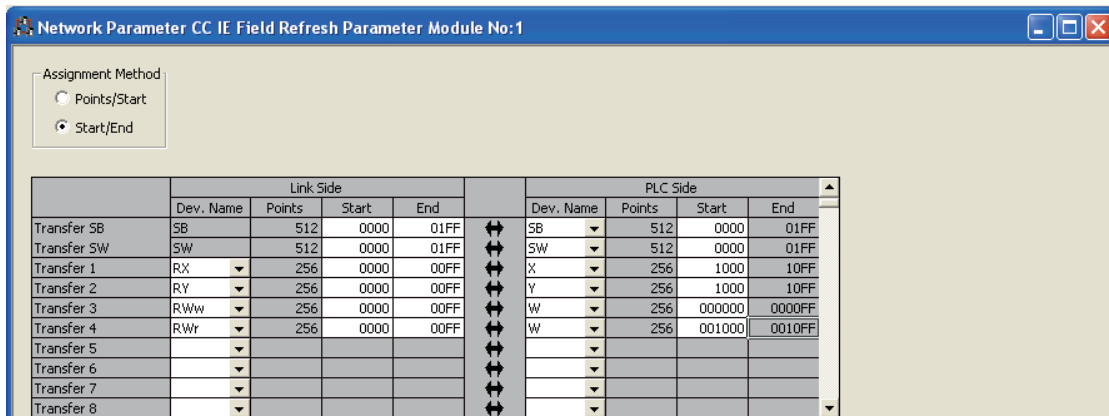

5. Write the set parameter to the CPU module of the master station and reset the CPU module, or turn off and then on the programmable controller power supply.

[Online] ⇨ [Write to PLC...]

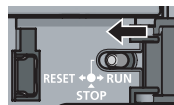

or Power OFF → ON

(6) Setting by intelligent device station

1. Create a project for GX Works2.

Select "LCPU" for "PLC Series" and select "LJ72GF15-T2" for "PLC Type."

 [Project] ⇒ [New...]

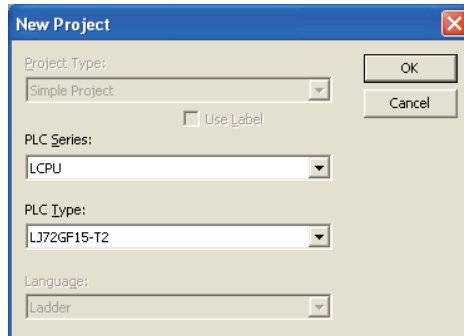

2. Display the PLC Parameter setting screen and configure the setting as follows.

 Project window ⇒ [Parameter] ⇒ [PLC Parameter] ⇒ "Communication Head Setting"

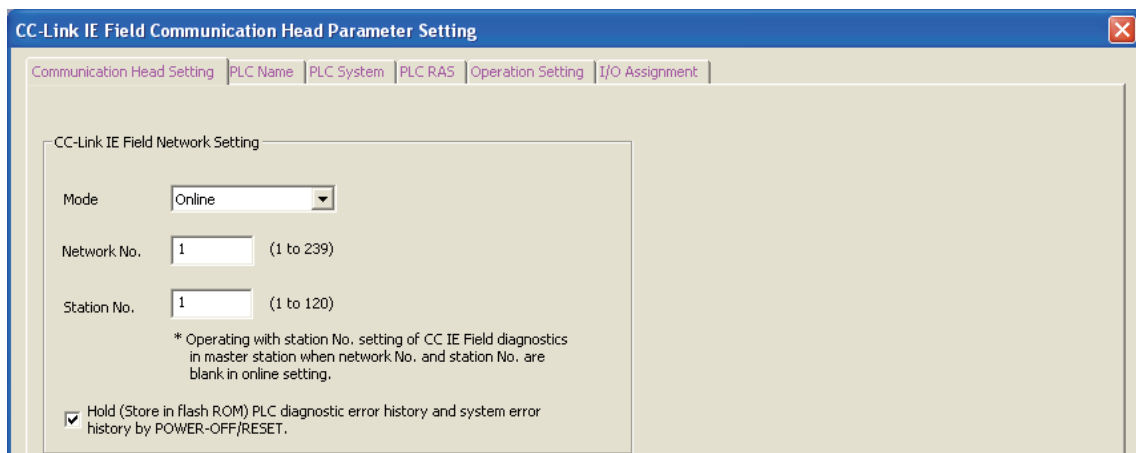

3. Add the A/D converter module (L60AD4) to the GX Works2 project.

Project window ⇨ [Intelligent Function Module] ⇨ Right-click ⇨ [New Module]

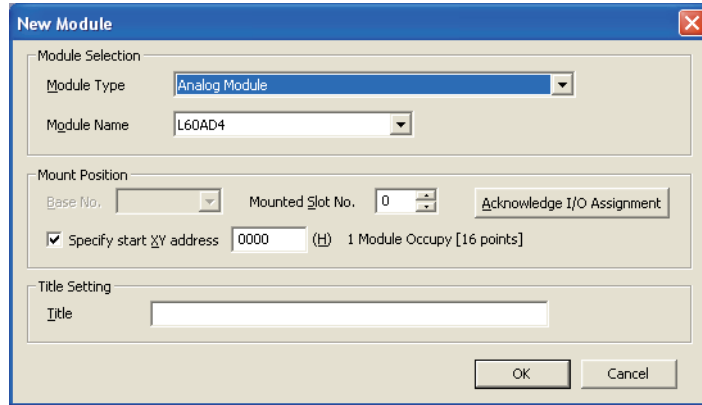

4. Display the Switch Setting screen for the A/D converter module (L60AD4) and configure the setting as follows.

Project window ⇨ [Intelligent Function Module] ⇨ [L60AD4] ⇨ [Switch Setting]

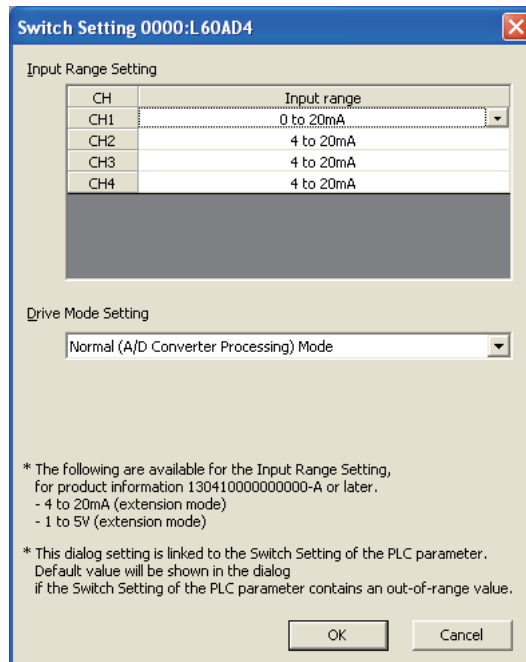

5. Display the initial setting screen for the A/D converter module (L60AD4) and configure the setting as follows.

Project window ⇨ [Intelligent Function Module] ⇨ [L60AD4] ⇨ [Parameter]

The screenshot shows the 'Parameter' configuration window for the L60AD4 module. The window title is '0000:L60AD4[]-Parameter'. A 'Display Filter' dropdown is set to 'Display All'. The main area is a table with columns for 'Item', 'CH1', 'CH2', 'CH3', and 'CH4'. The settings are organized into several sections:

- Basic setting**: Sets method of A/D conversion control.

Item	CH1	CH2	CH3	CH4
A/D conversion enable/disable setting	0:Enable	0:Enable	0:Enable	1:Disable
Averaging process setting	0:Sampling Processing	2:Count Average	3:Moving Average	0:Sampling Processing
Time Average/ Count Average/Moving Average	0	50 Times	5 Times	0
Conversion speed setting	0:20us			
- Warning output function**: Sets for warnings on A/D conversion.

Item	CH1	CH2	CH3	CH4
Warning output setting	1:Disable	0:Enable	1:Disable	1:Disable
Process alarm upper upper limit value	0	20000	0	0
Process alarm upper lower limit value	0	18000	0	0
Process alarm lower upper limit value	0	3000	0	0
Process alarm lower lower limit value	0	0	0	0
- Input signal error detection**: Sets for input signals on A/D conversion.

Item	CH1	CH2	CH3	CH4
Input signal error detection setting	0:Enable	1:Disable	1:Disable	1:Disable
Input signal error detection setting value	10.0 %	5.0 %	5.0 %	5.0 %
- Input signal error detection enhancing**: Set input signal error detection (enhancing) when A/D conversion is executed. Input signal error detection enhancing function will be detected by the Input signal error detection setting value.

Item	CH1	CH2	CH3	CH4
Input signal error detection extension setting	0:Disable	0:Disable	0:Disable	0:Disable
- Scaling function**: Sets for scaling on A/D conversion.

Item	CH1	CH2	CH3	CH4
Scaling enable/disable setting	1:Disable	1:Disable	0:Enable	1:Disable
Scaling upper limit value	0	0	32000	0
Scaling lower limit value	0	0	0	0
- Shift function**: Set shift function when A/D conversion is executed.

Item	CH1	CH2	CH3	CH4
Shifting amount to conversion value	0	0	10000	0
- Digital clipping function**: Set digital clipping function when A/D conversion is executed.

Item	CH1	CH2	CH3	CH4
Digital clipping function enable/disable setting	1:Disable	1:Disable	0:Enable	1:Disable

6. Display the Auto Refresh setting screen for the A/D converter module (L60AD4) and configure the setting as follows.

Project window ⇨ [Intelligent Function Module] ⇨ [L60AD4] ⇨ [Auto_Refresh]

The screenshot shows the 'Auto_Refresh' configuration window for the L60AD4 module. The window title is '0000:L60AD4[]-Auto_Refresh'. A 'Display Filter' dropdown is set to 'Display All'. The main area is a table with columns for 'Item', 'CH1', 'CH2', 'CH3', and 'CH4'. The settings are organized into sections:

- Transfer to PLC**: Transfers buffer memory data to the specified device.

Item	CH1	CH2	CH3	CH4
A/D conversion completed flag	W1000			
Digital output value	W1001	W1002		
Maximum value				
Minimum value				
Scaling value (Digital operation value)			W1028	
Warning output flag (Process alarm)	W1018			
Input signal error detection flag	W1008			
Latest error code	W1010			
Latest address of error history				
Difference conversion reference value				
(Available to Product Information 13041000000000-A or later)				
Difference conversion status flag				
(Available to Product Information 13041000000000-A or later)				
Logging hold flag				

7. Write the set parameter to the head module and reset the head module, or turn off and then on the programmable controller power supply.

 [Online] ⇨ [Write to PLC...]

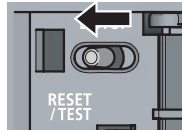

or Power OFF → ON

(7) Program example

The following shows a program example. The program can be written to the CPU module of the master station.

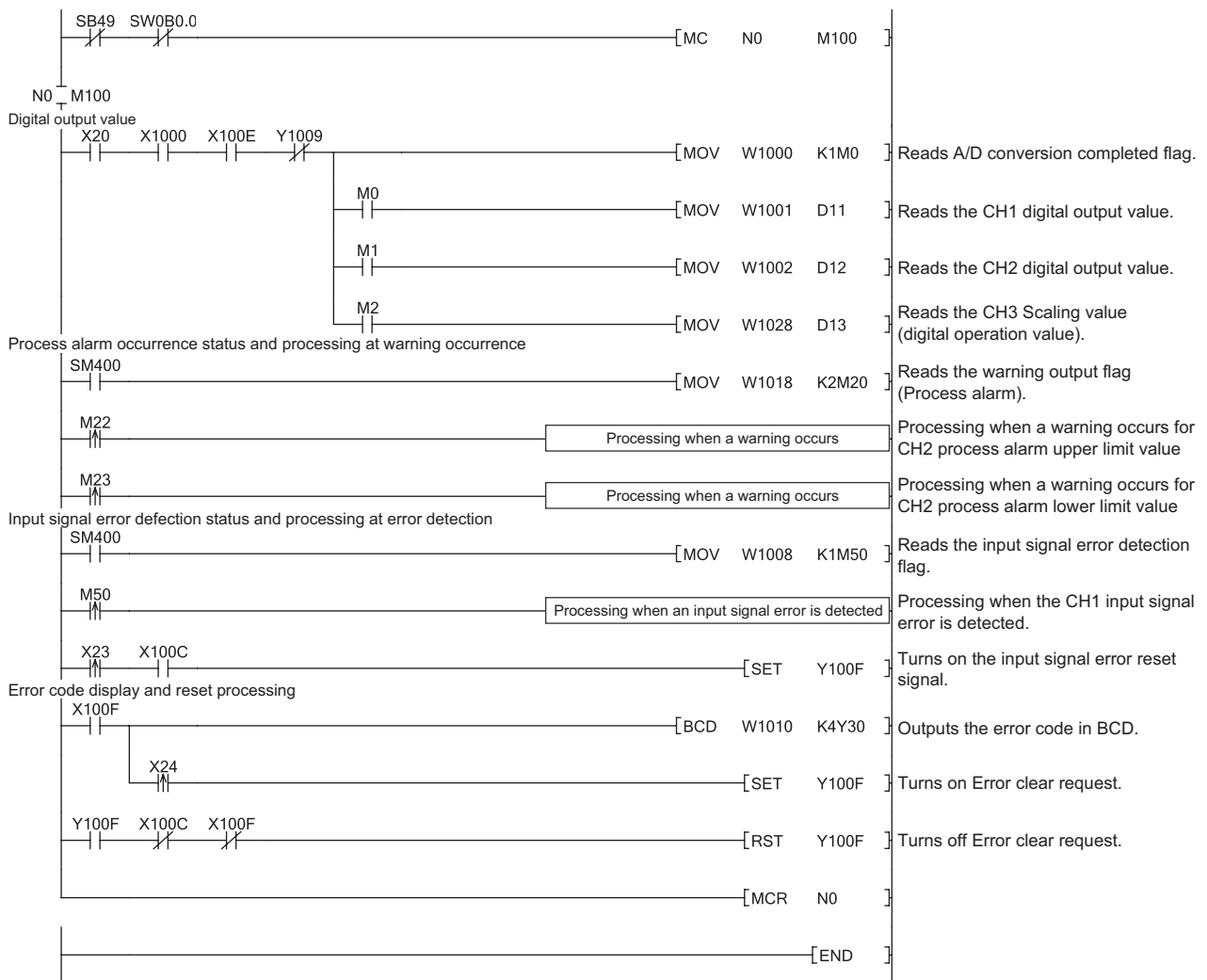

10.3 When A/D Converter Module is Connected to Head Module

CHAPTER 11 TROUBLESHOOTING

This chapter describes errors that may occur while the use of the A/D converter module, those troubleshooting.

(1) Checking for the error codes and the alarm codes

Errors and alarms occurred in the A/D converter module can be checked by any of the following methods:

- Checking on the module detailed Information (☞ Page 157, Section 11.1)
- Checking by Latest Error Code (Un\G19) (☞ Page 158, Section 11.2)
- Checking on the module error collection function (☞ Page 158, Section 11.3)
- Checking by a display unit (☞ Page 138, Section 9.4)

Choose the checking methods for the purpose and application.

11.1 Checking on the Module Detailed Information

The following describes how to check the errors on the module detailed information.

 [Diagnostics] ⇨ [System Monitor...]

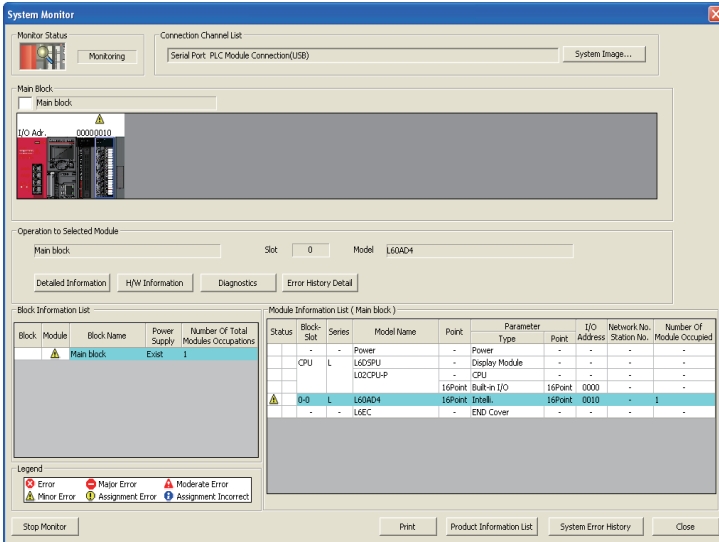

1. Select the A/D converter module in "Main Block" and click the **Detailed Information** button.

11

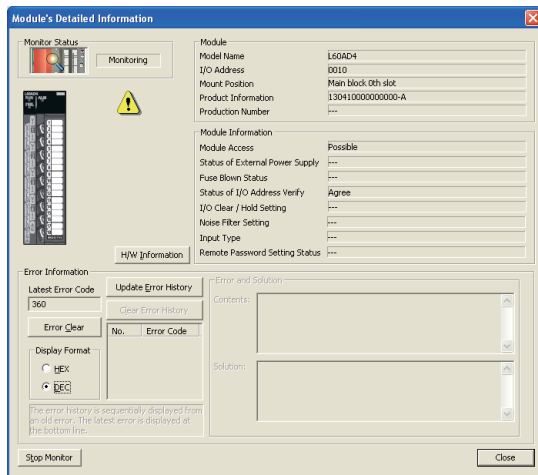

2. "Module's Detailed Information" of the A/D converter module is displayed.

11.2 Checking by Latest Error Code (Un\G19)

The following describes how to check the error codes and alarm codes in Latest error code (Un\G19).

 [Online] ⇨ [Monitor] ⇨ [Device/Buffer Memory Batch]

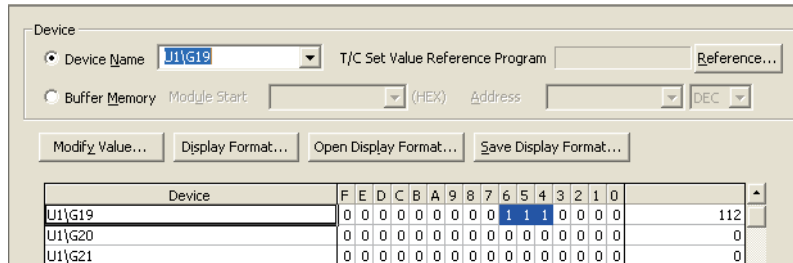

11.3 Checking on the Module Error Collection Function

Using the module error collection function stores the errors occurred in the A/D converter module to the CPU module or the head module. Once being stored, the errors remain even after powering off or resetting the CPU module or the head module.

(1) How to check the errors by the module error collection function

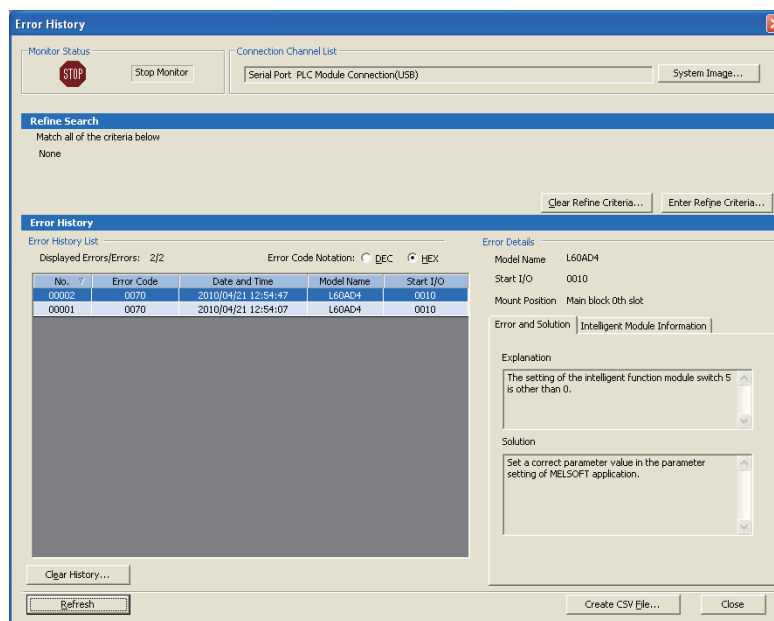

To check the errors of the A/D converter module collected by the CPU module, open the "Error History" dialog box.

 [Diagnostics] ⇨ [System Monitor...] ⇨ click the **Error History Detail** button



(2) Errors to be collected

The A/D converter module reports the following contents to the CPU module:

- Error code list ( Page 159, Section 11.4)
- Alarm code list ( Page 163, Section 11.5)

11.4 Error Code List

If the following errors occur on the A/D converter module while data is written to or read from the CPU module, the corresponding error code below is stored in Latest error code (Un\G19).

The error is reported to the CPU module also.

Error code (decimal)	Description and cause of error	Action
10□	The input range is set with a value outside the setting range for Switch 1 of the intelligent function module switch setting. The channel with the invalid setting fits in □.	Set a valid value on the intelligent function module switch setting in the parameter setting.
111	A hardware failure has occurred on the module.	Power off and on the module. If the error occurs again, a failure might have occurred on the module. Please consult a local Mitsubishi representative.
112	A value other than 0 is set to Switch 5 on the intelligent function module switch setting.	Set 0 to Switch 5 on the intelligent function module switch setting in the parameter setting.
113*1	The data in the flash memory has a problem.	Check the digital output value. If there is a problem of the digital output value, please consult a local Mitsubishi representative.
120*1	An invalid value is set to the offset/gain setting. The channel where the error has occurred cannot be identified.	Start over the offset/gain setting of all channels where the user range setting is used. If the error occurs again, a failure might have occurred on the module. Please consult a local Mitsubishi representative.
12□*1	An invalid value is set to the offset/gain setting. The channel where the error has occurred fits in □.	Start over the offset/gain setting of the channel where the error has occurred. If the error occurs again, a failure might have occurred on the module. Please consult a local Mitsubishi representative.
161*1*2	The G(P).OGSTOR instruction was executed in the offset/gain setting mode.	Do not execute the G(P).OGSTOR instruction in the offset/gain setting mode.
162*1	<ul style="list-style-type: none"> The G(P).OGSTOR instruction has been consecutively executed. For the offset/gain setting, a setting value has been consecutively written to the flash memory more than 25 times. 	<ul style="list-style-type: none"> Execute the G(P).OGSTOR instruction only once per module. Write the setting value into the flash memory only once for each offset/gain setting.
163*1	<ul style="list-style-type: none"> The G(P).OGSTOR instruction has been executed on a module different from the one on which the G(P).OGLOAD instruction was executed. The G(P).OGSTOR instruction has been executed ahead of the G(P).OGLOAD instruction. 	<ul style="list-style-type: none"> Execute the G(P).OGLOAD and G(P).OGSTOR instructions to the same module. After executing the G(P).OGLOAD instruction on the module from where data is restored, execute the G(P).OGSTOR instruction on the module to where the data is restored.
170*1	The offset/gain setting was configured exceeding the maximum number of times.	No more offset/gain setting is reflected on the operation successfully.

Error code (decimal)	Description and cause of error	Action
20□*1	<ul style="list-style-type: none"> Although the conversion speed has been set to 20μs, the averaging time value set in CH□ Time Average/Count Average/Moving Average (Un\G1 to Un\G4) is outside the range of 2 to 1500ms. Although the conversion speed has been set to 80μs or 1ms, the averaging time value set in CH□ Time Average/Count Average/Moving Average (Un\G1 to Un\G4) is outside the range of 2 to 5000ms. The averaging time value set in CH□ Time Average/Count Average/Moving Average (Un\G1 to Un\G4) is less than "4 × Number of used channels × Conversion speed" (ms). The channel where the error has occurred fits in □.	<ul style="list-style-type: none"> When the conversion speed is 20μs, set the averaging time to a value in the range of 2 to 1500ms. When the conversion speed is 80μs or 1ms, set the averaging time to a value in the range of 2 to 5000ms. Set the averaging time to a value equal to or more than "4 × Number of used channels × Conversion speed" (ms).
30□*1	The averaging count value set in CH□ Time Average/Count Average/Moving Average (Un\G1 to Un\G4) is outside the range of 4 to 62500. The channel where the error has occurred fits in □.	Set the averaging count to a value in the range of 4 to 62500.
31□*1	The moving average count value set in CH□ Time Average/Count Average/Moving Average (Un\G1 to Un\G4) is outside the range of 2 to 1000. The channel where the error has occurred fits in □.	Set the moving average count to a value in the range of 2 to 1000.
360*1	The value set in Conversion speed setting (Un\G26) is outside the range of 0 to 2.	Set one of the following values in Conversion speed setting (Un\G26). <ul style="list-style-type: none"> • 20μs (0) • 80μs (1) • 1ms (2)
37□*1	The value set in CH□ Difference conversion trigger (Un\G172 to Un\G175) is other than 0 and 1. The channel where the error has occurred fits in □.	Set the value in CH□ Difference conversion trigger (Un\G172 to Un\G175) to No request (0) or Trigger request (1).
40□*1	When the user range is set or restored, values are as follows: Offset value ≥ Gain value The channel where the error has occurred fits in □.	Set values so that they meet the following condition: Offset value < Gain value
500*1	When the offset/gain setting is configured, channels or 0s are set simultaneously in both Offset/gain setting mode Offset specification (Un\G22) and Offset/gain setting mode Gain specification (Un\G23).	Correct the setting in Offset/gain setting mode Offset specification (Un\G22) and/or the Offset/gain setting mode Gain specification (Un\G23).
6△□*1	The settings in CH1 Process alarm lower lower limit value (Un\G86) to CH4 Process alarm upper upper limit value (Un\G101) are invalid. The channel with the invalid setting fits in □. A value fits in △ indicates that the alarm status is as follows: <ol style="list-style-type: none"> 2: Process alarm lower lower limit value > Process alarm lower upper limit value 3: Process alarm lower upper limit value > Process alarm upper lower limit value 4: Process alarm upper lower limit value > Process alarm upper upper limit value 	Correct the settings in CH1 Process alarm lower lower limit value (Un\G86) to CH4 Process alarm upper upper limit value (Un\G101).
80□*1	The value set in CH□ Input signal error detection setting value (Un\G142 to Un\G145) is outside the range of 0 to 250. The channel where the error has occurred fits in □.	Set a value within the range of 0 to 250 in CH□ Input signal error detection setting value (Un\G142 to Un\G145).

Error code (decimal)	Description and cause of error	Action
81□*1	The value set in Input signal error detection extension setting (Un\G27) is outside the range of 0 to 4. The channel where the error has occurred fits in □.	Set one of the following values in Input signal error detection extension setting (Un\G27) for the channel where the error has occurred. <ul style="list-style-type: none"> • Disable (0) • Upper/lower limit detection (1) • Lower limit detection (2) • Upper limit detection (3) • Disconnection detection (4)
82□*1	A value set in Input signal error detection extension setting (Un\G27) is Disconnection detection (4), besides the set input range for the same channel is other than the following. <ul style="list-style-type: none"> • 4 to 20mA (Extended mode) • 1 to 5V (Extended mode) The channel where the error has occurred fits in □.	<ul style="list-style-type: none"> • To perform disconnection detection using the input signal error detection extension function, set the input range of the corresponding channel to 4 to 20mA (Extended mode) or 1 to 5V (Extended mode). • Not to perform disconnection detection using the input signal error detection extension function, set Input signal error detection extension setting (Un\G27) of the corresponding channel to the value other than Disconnection detection (4).
90□*1	The values set in CH1 Scaling lower limit value (Un\G62) to CH4 Scaling upper limit value (Un\G69) are outside the range of -32000 to 32000. The channel where the error has occurred fits in □.	Set a value within the range of -32000 to 32000 in CH1 Scaling lower limit value (Un\G62) to CH4 Scaling upper limit value (Un\G69).
91□*1	The values set in CH1 Scaling lower limit value (Un\G62) to CH4 Scaling upper limit value (Un\G69) are as follows: Scaling lower limit value ≥ Scaling upper limit value. The channel where the error has occurred fits in □.	Set the values in CH1 Scaling lower limit value (Un\G62) to CH4 Scaling upper limit value (Un\G69) so that they meet the following condition: Scaling upper limit value > Scaling lower limit value
99□*1*3	For some channels, user range setting is used and besides the scaling function is enabled. The channel with the invalid setting fits in □.	Disable the scaling function of the channel where a user range setting is used.
200□*1	CH□ Logging enable/disable setting (Un\G1000 to Un\G1003) is set to a value other than 0 and 1. The channel where the error has occurred fits in □.	Set Enable (0) or Disable (1) in CH□ Logging enable/disable setting (Un\G1000 to Un\G1003).
	Conversion speed is set to 20μs, and besides CH□ Logging enable/disable setting (Un\G1000 to Un\G1003) is set to Enable (0). The channel where the error has occurred fits in □.	To use the logging function, set the conversion speed to 80μs or 1ms.
201□*1	A value outside the setting range is set in one or both of CH□ Logging cycle setting value (Un\G1032 to Un\G1035) or/and CH□ Logging cycle unit setting (Un\G1040 to Un\G1043). The channel where the error has occurred fits in □.	Set a value within the setting range in one or both of CH□ Logging cycle setting value (Un\G1032 to Un\G1035) or/and CH□ Logging cycle unit setting (Un\G1040 to Un\G1043). For the setting method of the logging cycle, refer to the following. <ul style="list-style-type: none"> • Logging function (👉 Page 98, Section 8.14)
202□*1	The set logging cycle is shorter than the update cycle of the logged value (digital output value or scaling value (digital operation value)). The channel where the error has occurred fits in □.	Set CH□ Logging cycle setting value (Un\G1032 to Un\G1035) and CH□ Logging cycle unit setting (Un\G1040 to Un\G1043) so that the logging cycle is equal to or longer than the update cycle of the logged value. For the setting method of the logging cycle, refer to the following. <ul style="list-style-type: none"> • Logging function (👉 Page 98, Section 8.14)
203□*1	CH□ Logging data setting (Un\G1024 to Un\G1027) is set to a value other than 0 and 1. The channel where the error has occurred fits in □.	Set Digital output value (0) or Scaling value (digital operation value) (1) in CH□ Logging data setting (Un\G1024 to Un\G1027).

Error code (decimal)	Description and cause of error	Action
204□*1	CH□ Logging points after trigger (Un\G1048 to Un\G1051) is set to a value outside the range of 1 to 10000. The channel where the error has occurred fits in □.	Set a value within the range of 1 to 10000 in CH□ Logging points after trigger (Un\G1048 to Un\G1051).
205□*1	CH□ Level trigger condition setting (Un\G1056 to Un\G1059) is set to a value outside the range of 0 to 3. The channel where the error has occurred fits in □.	Set one of the following values in CH□ Level trigger condition setting (Un\G1056 to Un\G1059). • Disable (0) • Above (1) • Below (2) • Pass through (3)
206□*1	CH□ Trigger data (Un\G1064 to Un\G1067) is set to a value outside the range of 0 to 4999. The channel where the error has occurred fits in □.	Set a value within the range of 0 to 4999 in CH□ Trigger data (Un\G1064 to Un\G1067).
207□*1	CH□ Logging hold request (Un\G1008 to Un\G1011) is set to a value other than 0 and 1. The channel where the error has occurred fits in □.	Set OFF (0) or ON (1) in CH□ Logging hold request (Un\G1008 to Un\G1011).
208□*1	CH□ Logging enable/disable setting (Un\G1000 to Un\G1003) is set to Enable (0), and besides the input signal error detection function or the input signal error detection extension function is enabled. The channel where the error has occurred fits in □.	To use the logging function, set the following buffer memory areas as below. • Set Disable (0) in Input signal error detection extension setting (Un\G27) • Set Disable (1) in Input signal error detection setting (Un\G47).
210□*1	CH□ Flow amount integration enable/disable setting (Un\G1300 to Un\G1303) is set to a value other than 0 and 1. The channel where the error has occurred fits in □.	Set Enable (0) or Disable (1) in CH□ Flow amount integration enable/disable setting (Un\G1300 to Un\G1303).
	Conversion speed is set to 20μs or 80μs, and besides CH□ Flow amount integration enable/disable setting (Un\G1300 to Un\G1303) is set to Enable (0). The channel where the error has occurred fits in □.	To use the flow amount integration function, set the conversion speed to 1ms.
211□*1	CH□ Integration cycle setting (Un\G1308 to Un\G1311) is set to a value outside the range of 1 to 5000. The channel where the error has occurred fits in □.	Set a value within the range of 1 to 5000 in CH□ Integration cycle setting (Un\G1308 to Un\G1311).
212□*1	The set value in CH□ Integration cycle setting (Un\G1308 to Un\G1311) is shorter than the update cycle of CH□ Scaling value (digital operation value) (Un\G54 to Un\G57). The channel where the error has occurred fits in □.	Set CH□ Integration cycle setting (Un\G1308 to Un\G1311) so that the integration cycle is equal to or longer than the update cycle of CH□ Scaling value (digital operation value) (Un\G54 to Un\G57). For the setting method of the integration cycle, refer to the following. Flow amount integration function ( Page 110, Section 8.15)
213□*1	CH□ Flow amount time unit setting (Un\G1316 to Un\G1319) is set to a value outside the range of 0 to 2. The channel where the error has occurred fits in □.	Set one of the following values in CH□ Flow amount time unit setting (Un\G1316 to Un\G1319). • /s (0) • /min (1) • /h (2)
214□*1	CH□ Unit scaling setting (Un\G1324 to Un\G1327) is set to a value outside the range of 0 to 4. The channel where the error has occurred fits in □.	Set one of the following values in CH□ Unit scaling setting (Un\G1324 to Un\G1327). • × 1 (0) • × 10 (1) • × 100 (2) • × 1000 (3) • × 10000 (4)
215□*1	CH□ Flow amount integration temporary stop request (Un\G1356 to Un\G1359) is set to a value other than 0 and 1. The channel where the error has occurred fits in □.	Set No request (0) or Temporary stop request (1) in CH□ Flow amount integration temporary stop request (Un\G1356 to Un\G1359).

Error code (decimal)	Description and cause of error	Action
216□*1	CH□ Integrated flow amount clear request (Un\G1372 to Un\G1375) is set to a value other than 0 and 1. The channel where the error has occurred fits in □.	Set No request (0) or Clear request (1) in CH□ Integrated flow amount clear request (Un\G1372 to Un\G1375).

*1 This error code can be cleared by turning off, on, and then off Error clear request (YF).

*2 An error code is not stored in Latest error code (Un\G19) but in the completion status of the G(P). OGSTOR instruction (Ⓢ + 1).

*3 For A/D converter modules whose serial number (first five digits) is 13041 or later, the scaling function can be used on the channel where a user range setting is used; therefore, an error does not occur.

11.5 Alarm Code List

The following shows an alarm code list.

Alarm code (decimal)	Description and cause of alarm	Action
10△□	A process alarm is occurring. The channel where the process alarm has occurred fits in □. A value fits in △ indicates that the alarm status is as follows: 0: Upper limit of a process alarm 1: Lower limit of a process alarm	When the scaling value (digital operation value) returns to the one within the setting range, the corresponding bit of Warning output flag (Process alarm) (Un\G50) and Warning output signal (X8) turn off. The alarm code can be cleared by turning off, on, and off Error clear request (YF) after the scaling value (digital operation value) returns to the one within the setting range.
110□	An input signal error is occurring. The channel where the input signal error has occurred fits in □. This alarm code is stored when an input signal error is detected according to the setting of the input signal error detection function.	The corresponding bit of Input signal error detection flag (Un\G49) and Input signal error detection signal (XC) turn off by turning off, on, and off Error clear request (YF) after the analog input value returns to the one within the setting range.
11△□	An input signal error is occurring. The channel where the input signal error has occurred fits in □. A value fits in △ indicates that the detection status is as follows: 1: Upper limit detection 2: Lower limit detection 3: Disconnection detection This alarm code is stored when an input signal error is detected according to the setting of the input signal error detection extension function.	

11.6 Troubleshooting

(1) When the RUN LED flashes or turns off

(a) When flashing

Check item	Action
Is the operation mode setting in the offset/gain setting mode?	Take the either of the following actions: <ul style="list-style-type: none"> • switch the operation mode setting in the intelligent function module switch setting to the normal mode, or • correct Switch4 in the intelligent function module switch setting to switch the operation mode setting to the normal mode.

(b) When turning off

Check item	Action
Is the power supplied?	Check that the supply voltage of power supply module is within the rated range.
Is the capacity of power supply module enough?	Make sure that the power capacity is enough by calculating the current consumption such as a connected CPU module, an I/O module, and an intelligent function modules.
Is there any watchdog timer error?	Reset the CPU module, and check if the RUN LED turns on. If the RUN LED remains off, the module may be failed. Please consult a local Mitsubishi representative.
Is the module connected properly?	Check the module connection.

(2) When the ERR. LED turns on or flashes

(a) When turning on

Check item	Action
Does any error occur?	Check the error code, and take the action described in the error code list. <ul style="list-style-type: none"> • Error Code List (👉 Page 159, Section 11.4)

(b) When flashing

Check item	Action
Is the value other than 0 set for Switch 5 of the intelligent function module switch setting?	With the parameter setting, set 0 for Switch 5 in the intelligent function module switch setting.

(3) When the ALM LED turns on or flashes

(a) When turning on

Check item	Action
Is there any alarm output?	Check Warning output flag (Process alarm) (Un\G50).

(b) When flashing

Check item	Action
Is there any input signal error?	Check Input signal error detection flag (Un\G49)

(4) When digital output value cannot be read

Check item	Action
Is there any problem with wiring, such as off or disconnection of analog signal lines?	Check the faulty area by checking signal line visually or conductively.
Is the CPU module in the STOP status?	Change the status of the CPU module to RUN.
Is the offset/gain setting correct?	Check if the offset/gain setting is correct. When the user range setting is selected, change the input range to the factory default setting. Then check if the A/D conversion executes. If the A/D conversion is properly executed, configure the offset/gain setting again.
Is input range setting correct?	Check Setting range (Un\G20). When the setting range is wrong, perform the intelligent function module switch setting again.
Of the channels to input the analog value, is there any channel, whose A/D conversion enable/disable setting (Un\G0) set to the A/D conversion disable?	Check A/D conversion enable/disable setting (Un\G0). Then, set the A/D conversion enable for Un\G0 with the program or the parameter of the intelligent function module.
Is Operating condition setting request (Y9) performed?	Check if the digital output value is stored in the CH□ Digital output value (Un\G11 to Un\G14) after turning Operating condition setting request (Y9) from OFF to ON, then to OFF. When the problem has been solved, check the program again.
Are the (V+) and (I+) terminals connected if the input source is current?	Make sure to connect the (V+) and (I+) terminals while inputting current as shown in the external wiring.
Are the setting values correct when the average processing is specified?	When selecting the time average processing, set the values satisfy the following condition. • Setting value \geq "4 (times) \times conversion speed \times Number of used channels" If the condition above is not met, digital output values remain 0.
Is there any potential difference between the AG terminal and the external device GND?	Connect the AG terminal and the external device GND

Point 

If digital output value cannot be read even after taking the above actions, the A/D converter module may be failed. Please consult a local Mitsubishi representative.

(5) When an A/D conversion completed flag does not turn on in the normal mode

Check item	Action
Isn't there any input signal error?	Check Input signal error detection flag (Un\G49)

11.7 Checking the Status of the A/D Converter Module by the System Monitor

To check the LED status or the setting status of the intelligent function module switch setting, select the H/W information of the A/D converter module on the system monitor of GX Works2.

(1) Hardware LED information

LED status is displayed.

No.	LED name	Status
1)	RUN LED	0000 _H : Indicates the LED off. 0001 _H : Indicates the LED on.
2)	ERR. LED	Alternating indication between 0000 _H and 0001 _H : Indicates the LED flashing.
3)	ALM LED	(GX Works2 displays the communication status with the A/D converter module, so that the displaying intervals of 0000 _H and 0001 _H are not always even.)

(2) Hardware switch information

The setting status of the intelligent function module switch setting is displayed.

For details on the setting status, refer to the following.

- Intelligent function module switch setting (☞ Page 227, Appendix 9.1(2))

Item	Intelligent function module switch
RANGE	Switch1
—	Switch2
—	Switch3
MODE	Switch4
—	Switch5

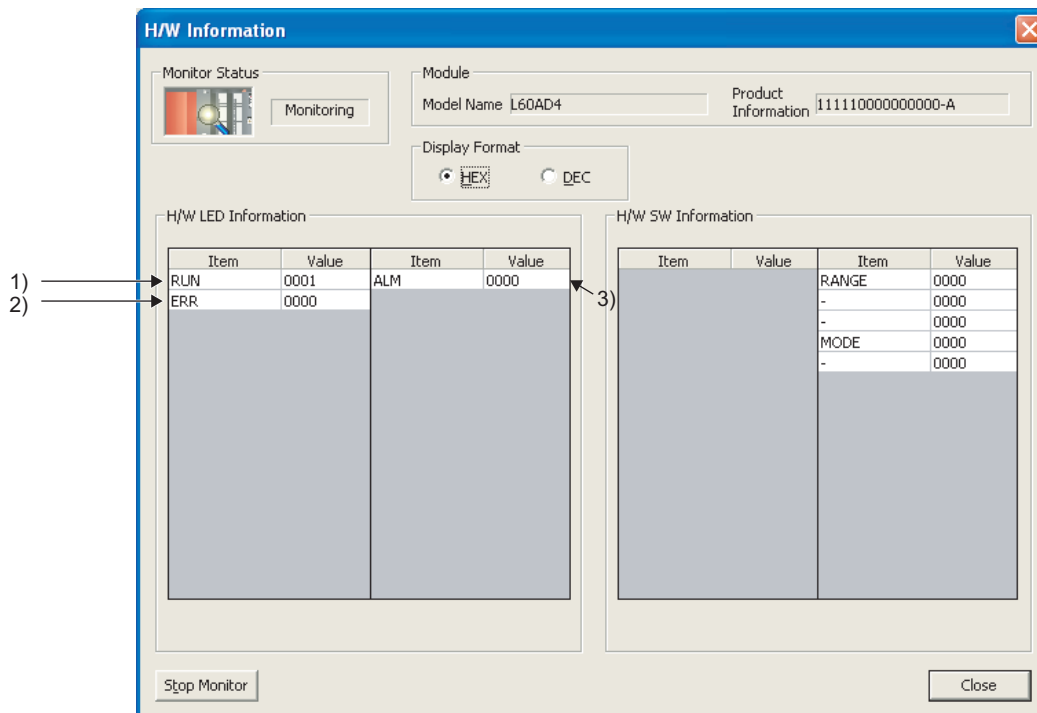

APPENDICES

Appendix 1 Details of I/O Signals

The following describes the details of the A/D converter module I/O signals assigned to the CPU module.

The I/O numbers (X/Y) described in Appendix 1 are for the case when the start I/O number of the A/D converter module is set to 0.

Appendix 1.1 Input signal

A

(1) Module READY (X0)

Module READY (X0) turns ON to indicate the preparation for the A/D conversion is completed after the power-on or after the reset operation of the CPU module, and then the A/D conversion is proceeded.

In the following cases, Module READY (X0) turns off.

- In the offset/gain setting mode (In this case, the A/D conversion processing is executed)
- When a watch dog timer error occurs to the A/D converter module (In this case, the A/D conversion processing is not executed)

(2) Warning output signal (X8)

Warning output signal (X8) turns ON when the process alarm has been detected.

(a) Process alarm

- Warning output signal (X8) turns ON when digital output values of the A/D conversion enabled channels exceed the ranges set for CH1 Process alarm lower limit value (Un\G86) to CH4 Process alarm upper limit value (Un\G101) after validating the alarm output setting (process alarm). The ALM LED also turns on along with the on of the signal.
- Warning output signal (X8) turns OFF when the digital output values fall within the setting range for all the A/D conversion enabled channels.

The ALM LED also turns off along with the off of the signal.

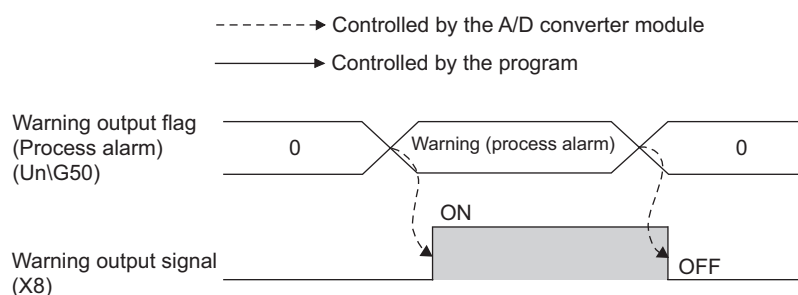

(3) Operating condition setting completed flag (X9)

When changing the following settings, use Operating condition setting completed flag (X9) as an interlock condition to turn Operating condition setting request (Y9) OFF → ON → OFF.

- A/D conversion enable/disable setting (Un\G0)
- CH□ Time Average/ Count Average/Moving Average (Un\G1 to Un\G4)
- Averaging process setting (used to replace Q64AD) (Un\G9)
- Averaging process setting (Un\G24)
- Conversion speed setting (Un\G26)
- Input signal error detection extension setting (Un\G27)
- Digital clipping enable/disable setting (Un\G29)
- Input signal error detection setting (Un\G47)
- Warning output setting (Un\G48)
- Scaling enable/disable setting (Un\G53)
- CH□ Scaling lower limit value (Un\G62, Un\G64, Un\G66, Un\G68)
- CH□ Scaling upper limit value (Un\G63, Un\G65, Un\G67, Un\G69)
- CH□ Process alarm lower lower limit value (Un\G86, Un\G90, Un\G94, Un\G98)
- CH□ Process alarm lower upper limit value (Un\G87, Un\G91, Un\G95, Un\G99)
- CH□ Process alarm upper lower limit value (Un\G88, Un\G92, Un\G96, Un\G100)
- CH□ Process alarm upper upper limit value (Un\G89, Un\G93, Un\G97, Un\G101)
- CH□ Input signal error detection setting value (Un\G142 to Un\G145)
- CH□ Logging enable/disable setting (Un\G1000 to Un\G1003)
- CH□ Logging data setting (Un\G1024 to Un\G1027)
- CH□ Logging cycle setting value (Un\G1032 to Un\G1035)
- CH□ Logging cycle unit setting (Un\G1040 to Un\G1043)
- CH□ Logging points after trigger (Un\G1048 to Un\G1051)
- CH□ Level trigger condition setting (Un\G1056 to Un\G1059)
- CH□ Trigger data (Un\G1064 to Un\G1067)
- CH□ Trigger setting value (Un\G1082 to Un\G1085)
- CH□ Flow amount integration enable/disable setting (Un\G1300 to Un\G1303)
- CH□ Integration cycle setting (Un\G1308 to Un\G1311)
- CH□ Flow amount time unit setting (Un\G1316 to Un\G1319)
- CH□ Unit scaling setting (Un\G1324 to Un\G1327)

When Operating condition setting completed flag (X9) is OFF, the A/D conversion processing is not executed. In the case of the following status, Operating condition setting completed flag (X9) turns OFF.

- When Operating condition setting request (Y9) is ON

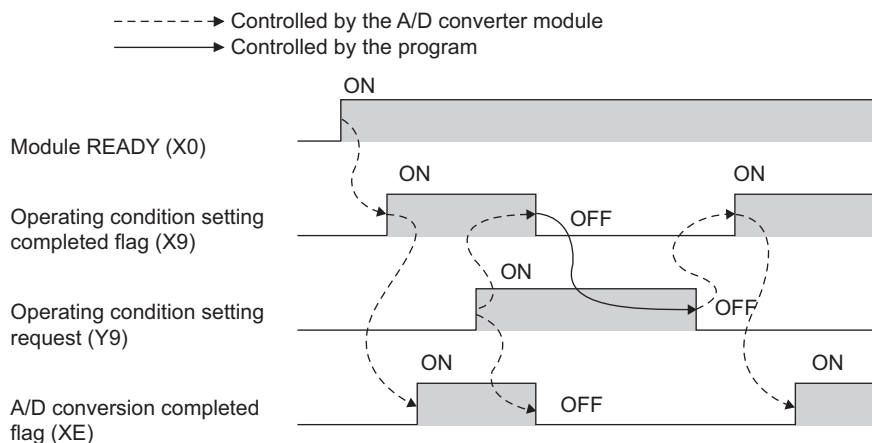

(4) Offset/gain setting mode flag (XA)

(a) Offset/gain setting mode

When registering the value, which was adjusted with the offset/gain setting, to the module, use Offset/gain setting mode flag (XA) as an interlock condition to turn User range write request (YA) OFF → ON → OFF.

For the offset/gain setting, refer to the following.

- Offset/gain setting (☞ Page 54, Section 7.5)

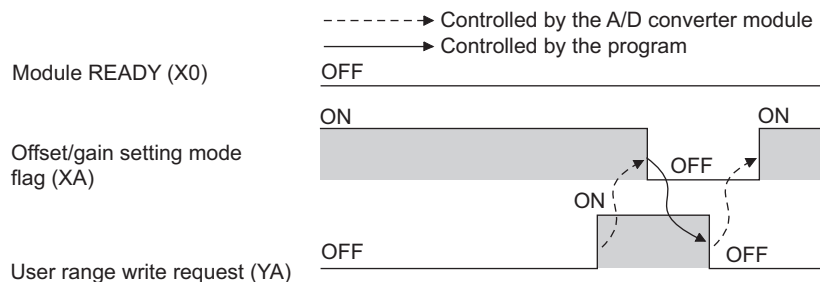

(b) Normal mode

In the user range restoration, use Offset/gain setting mode flag (XA) as an interlock condition to turn User range write request (YA) OFF → ON → OFF.

For user range restoration, refer to the following.

- Save/restoration of offset/gain value (☞ Page 124, Section 8.19)

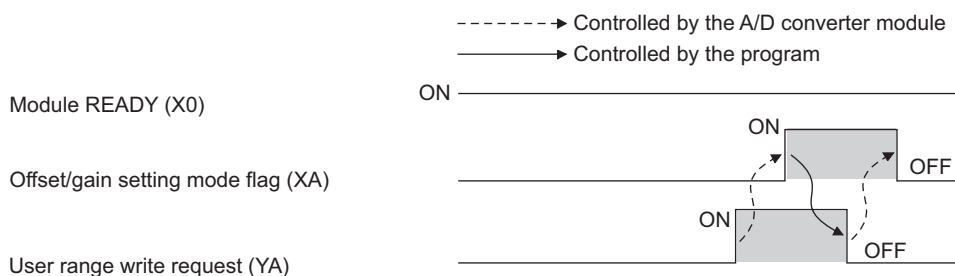

(5) Channel change completed flag (XB)

When changing a channel to perform the offset/gain setting, use Channel change completed flag (XB) as an interlock condition to turn Channel change request (YB) OFF → ON → OFF.

For the offset/gain setting, refer to the following.

- Offset/gain setting (☞ Page 54, Section 7.5)

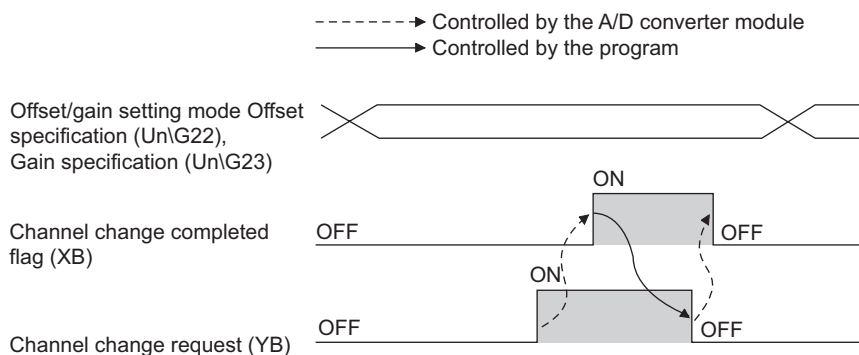

A

Appendix 1 Details of I/O Signals
Appendix 1.1 Input signal

(6) Input signal error detection signal (XC)

(a) Turning Input signal error detection signal (XC) ON

- Input signal error detection signal (XC) turns to ON when an analog input value exceeds the range set with CH□ Input signal error detection setting value (Un\G142 to Un\G145) in any channel which has been A/D conversion-enabled, after validating Input signal error detection setting (Un\G47).
- Input signal error detection signal (XC) turns to ON when an analog input value exceeds the range set with CH□ Input signal error detection setting value (Un\G142 to Un\G145) in any channel which has been A/D conversion-enabled, after setting the detection condition in Input signal error detection extension setting (Un\G27). When the disconnection detection is set, the signal ignores the setting for CH□ Input signal error detection setting value (Un\G142 to Un\G145), and turns to ON at the disconnection detection.

(b) Turning Input signal error detection signal (XC) OFF

After setting the analog input value within the range set, turn Error clear request (YF) OFF → ON → OFF to turn OFF Input signal error detection signal (XC).

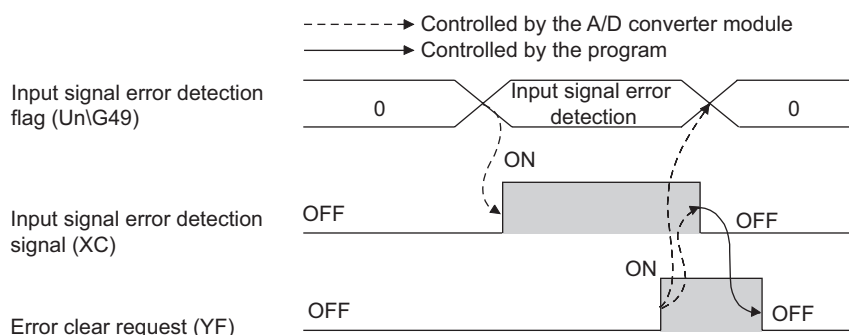

(c) When Input signal error detection signal (XC) turns ON

- A/D conversion completed flag (Un\G10) for the corresponding channels turns OFF.
- For the error detected channel, the digital output value immediately before the error detection is held in the buffer memory.
- ALM LED flashes.

(d) When Input signal error detection signal (XC) turns OFF

- ALM LED turns off.
- Latest error code (Un\G19) is cleared.

Point

When the analog input value falls within the range set, A/D conversion resumes regardless of Input signal error detection signal (XC) reset.

When the first A/D conversion after the resumption is completed, A/D conversion completed flag (Un\G10) is turned to A/D conversion completion (1).

Averaging processing starts over after the A/D conversion resumed.

(7) Maximum value/minimum value reset completed flag (XD)

Maximum value/minimum value reset completed flag (XD) turns ON after resetting the maximum or minimum values stored in CH□ Maximum value (Un\G30, Un\G32, Un\G34, Un\G36) and CH□ Minimum value (Un\G31, Un\G33, Un\G35, Un\G37) by turning Maximum value/minimum value reset request (YD) OFF → ON → OFF.

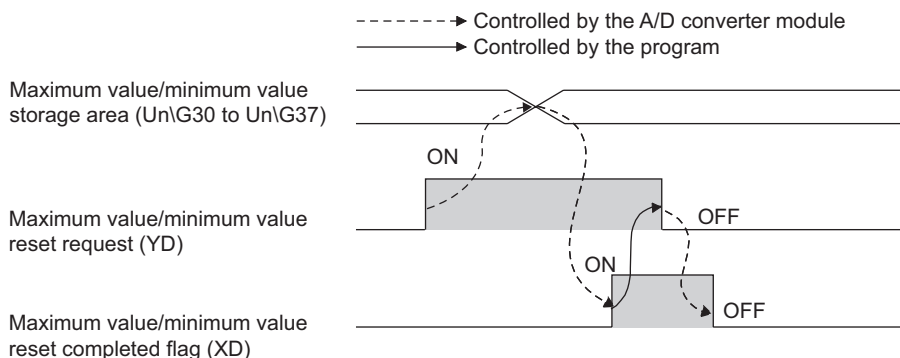

(8) A/D conversion completed flag (XE)

A/D conversion completed flag (XE) turns ON when all A/D conversion-enabled channels are converted.

(9) Error flag (XF)

Error flag (XF) turns ON when an error occurs.

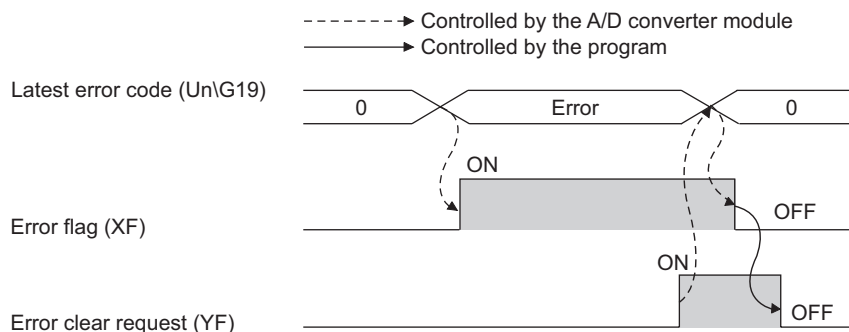

(a) Clearing the latest error code and Error flag (XF)

Turn Error clear request (YF) OFF → ON → OFF.

A

Appendix 1 Details of I/O Signals
 Appendix 1.1 Input signal

Appendix 1.2 Output signal

(1) Operating condition setting request (Y9)

To validate the following settings, turn Operating condition setting request (Y9) OFF → ON → OFF.

- A/D conversion enable/disable setting (Un\G0)
- CH□ Time Average/ Count Average/Moving Average (Un\G1 to Un\G4)
- Averaging process setting (used to replace Q64AD) (Un\G9)
- Averaging process setting (Un\G24)
- Conversion speed setting (Un\G26)
- Input signal error detection extension setting (Un\G27)
- Digital clipping enable/disable setting (Un\G29)
- Input signal error detection setting (Un\G47)
- Warning output setting (Un\G48)
- Scaling enable/disable setting (Un\G53)
- CH□ Scaling lower limit value (Un\G62, Un\G64, Un\G66, Un\G68)
- CH□ Scaling upper limit value (Un\G63, Un\G65, Un\G67, Un\G69)
- CH□ Process alarm lower lower limit value (Un\G86, Un\G90, Un\G94, Un\G98)
- CH□ Process alarm lower upper limit value (Un\G87, Un\G91, Un\G95, Un\G99)
- CH□ Process alarm upper lower limit value (Un\G88, Un\G92, Un\G96, Un\G100)
- CH□ Process alarm upper upper limit value (Un\G89, Un\G93, Un\G97, Un\G101)
- CH□ Input signal error detection setting value (Un\G142 to Un\G145)
- CH□ Logging enable/disable setting (Un\G1000 to Un\G1003)
- CH□ Logging data setting (Un\G1024 to Un\G1027)
- CH□ Logging cycle setting value (Un\G1032 to Un\G1035)
- CH□ Logging cycle unit setting (Un\G1040 to Un\G1043)
- CH□ Logging points after trigger (Un\G1048 to Un\G1051)
- CH□ Level trigger condition setting (Un\G1056 to Un\G1059)
- CH□ Trigger data (Un\G1064 to Un\G1067)
- CH□ Trigger setting value (Un\G1082 to Un\G1085)
- CH□ Flow amount integration enable/disable setting (Un\G1300 to Un\G1303)
- CH□ Integration cycle setting (Un\G1308 to Un\G1311)
- CH□ Flow amount time unit setting (Un\G1316 to Un\G1319)
- CH□ Unit scaling setting (Un\G1324 to Un\G1327)

For the timing of turning the signal OFF → ON → OFF, refer to the following.

- Operating condition setting completed flag (X9) (☞ Page 167, Appendix 1.1)

(2) User range write request (YA)

(a) Offset/gain setting mode

Turn User range write request (YA) OFF → ON → OFF to register the adjusted offset/gain setting values in the A/D converter module.

The data is written to the flash memory at the timing when this signal is turned on from off.

For the timing of turning the signal OFF → ON → OFF, refer to the following.

- Offset/gain setting mode flag (XA) (☞ Page 167, Appendix 1.1)

(b) Normal mode

Turn User range write request (YA) OFF → ON → OFF to perform the user range restoration.

For the timing of turning the signal OFF → ON → OFF, refer to the following.

- Offset/gain setting mode flag (XA) (☞ Page 167, Appendix 1.1)

(3) Channel change request (YB)

Turn Channel change request (YB) OFF → ON → OFF to change a channel to perform the offset/gain setting. For the timing of turning the signal OFF → ON → OFF, refer to the following.

- Channel change completed flag (XB) (☞ Page 167, Appendix 1.1)

(4) Maximum value/minimum value reset request (YD)

Turn Maximum value/minimum value reset request (YD) OFF → ON → OFF to clear the maximum or minimum values stored in CH□ Maximum value (Un\G30, Un\G32, Un\G34, Un\G36) and CH□ Minimum value (Un\G31, Un\G33, Un\G35, Un\G37).

For the timing of turning the signal OFF → ON → OFF, refer to the following.

- Maximum value/minimum value reset completed flag (XD) (☞ Page 167, Appendix 1.1)

(5) Error clear request (YF)

To clear Error flag (XF), Input signal error detection signal (XC), and Latest error code (Un\G19), turn Error clear request (YF) OFF → ON → OFF.

For the timing of turning the signal OFF → ON → OFF, refer to the following.

- Input signal error detection signal (XC) (☞ Page 167, Appendix 1.1)
- Error flag (XF) (☞ Page 167, Appendix 1.1)

Appendix 2 Details of Buffer Memory Addresses

The following describes the details of buffer memory addresses of the A/D converter module.

(1) A/D conversion enable/disable setting (Un\G0)

Set if the A/D conversion is enabled or disabled for each channel.

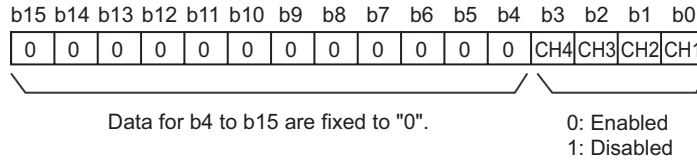

(a) Enabling the setting

Turn OFF → ON → OFF Operating condition setting request (Y9) to enable the setting.

(b) Default value

All channels are set to A/D conversion enable (0) as the default value.

(2) CH□ Time Average/ Count Average/Moving Average (Un\G1 to Un\G4)

Configure the time/count/moving average setting for each channel to which the averaging processing is specified. The following shows the setting range.

Processing method	Conversion speed setting	Setting range
Time average	20μs	2 to 1500 (ms)
	80μs, 1ms	2 to 5000 (ms)
Count average	20μs, 80μs, 1ms	4 to 62500 (times) ^{*1}
Moving average	20μs, 80μs, 1ms	2 to 1000 (times)

*1 When specifying a setting between 32768 and 62500 (times) in the program, configure the setting in hexadecimal.

Ex. When specifying a setting of 62500 (times), set F424_H.

(a) Enabling the setting

Turn OFF → ON → OFF Operating condition setting request (Y9) to enable the setting.

(b) Default value

All channels are set to Disable (0).

Point

- When the value out of the setting range above is written, an error occurs in the channel to which the value is written, the error code is stored in Latest error code (Un\G19) and Error flag (XF) is turned ON. The A/D conversion is processed in the setting configured before the error occurrence.
- 0 is set as default value, so change the value according to the processing method.
- When the sampling is set to the channel to which the setting value has been set, the setting value is ignored.

(3) Averaging process setting (used to replace Q64AD) (Un\G9)

Write the setting for averaging processing when using the sequence program for initial setting of the Q64AD.

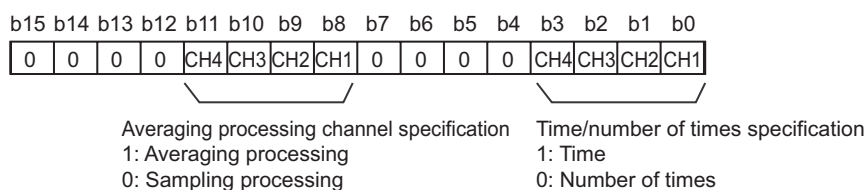

(a) Enabling the setting

To enable the setting, turn OFF → ON → OFF Operating condition setting request (Y9) after setting Averaging process setting (Un\G24) to sampling processing (0).

Point

When selecting the moving average, it is necessary to write 0 to (Un\G9), and write the moving average to Averaging process setting (Un\G24).

(b) Default value

All channels are set to sampling (0) as the default value.

(4) A/D conversion completed flag (Un\G10)

A/D conversion status can be checked with this flag.

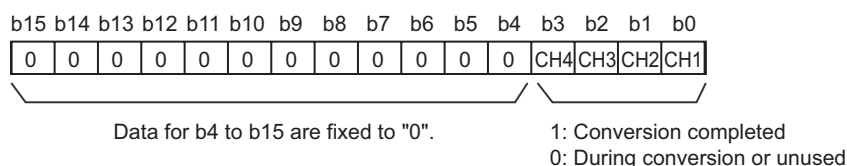

(a) A/D conversion completion

When the first A/D conversion is completed in the channel where the A/D conversion is enabled, the flag is turned to A/D conversion completion (1).

A/D conversion completed flag (XE) is turned to ON when the conversion of all the channels where the A/D conversion is enabled are completed.

Turning OFF → ON → OFF Operating condition setting request (Y9) turns the flag to 0 (default value), and the flag is turned to A/D conversion completion (1) when the first A/D conversion is completed.

Ex. When A/D conversion enable is set to CH1 and CH2 and all the A/D conversions in CH1 and CH2 are completed, 0003_H(3) is stored in A/D conversion completed flag (Un\G10), as shown below.

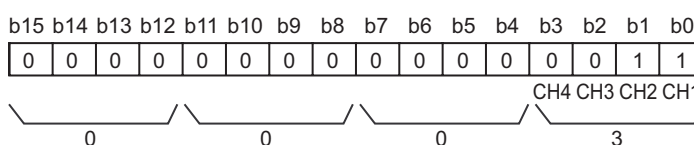

(5) CH□ Digital output value (Un\G11 to Un\G14)

The A/D-converted digital output value is stored as a signed 16-bit binary.

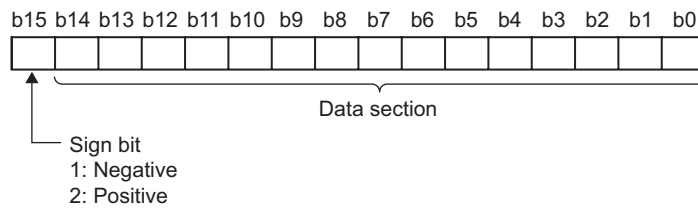

(a) Updating cycle

When performing the average processing, the value is updated in each specified averaging processing cycle.
When the average processing is not performed, the value is updated in each sampling cycle.

(6) Latest error code (Un\G19)

Error codes or alarm codes detected in the A/D converter module are stored.

For details on error code and alarm code, refer to the following.

- Error code list (☞ Page 159, Section 11.4)
- Alarm code list (☞ Page 163, Section 11.5)

(a) Clearing an error

Turn OFF → ON → OFF Error clear request (YF).

(7) Setting range (Un\G20)

The setting content for input range can be checked.

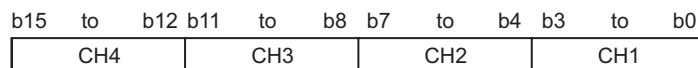

Input range	Setting value
4 to 20mA	0 _H
0 to 20mA	1 _H
1 to 5V	2 _H
0 to 5V	3 _H
-10 to 10V	4 _H
0 to 10V	5 _H
4 to 20mA (Extended mode)	A _H
1 to 5V (Extended mode)	B _H
User range setting	F _H

Point

Input range cannot be changed in Setting range (Un\G20).
For changing the setting, refer to the following.

- Switch setting (☞ Page 49, Section 7.2)

(8) Offset/gain setting mode Offset specification (Un\G22), Offset/gain setting mode Gain specification (Un\G23)

Specify the channel to perform the offset/gain setting adjustment.

Offset/gain setting mode Offset specification (Un\G22): channel to adjust the offset

Offset/gain setting mode Gain specification (Un\G23): channel to adjust the gain

	b15	b14	b13	b12	b11	b10	b9	b8	b7	b6	b5	b4	b3	b2	b1	b0
Offset/gain setting mode Offset specification (Un\G22)	0	0	0	0	0	0	0	0	0	0	0	0	CH4	CH3	CH2	CH1
Offset/gain setting mode Gain specification (Un\G23)	0	0	0	0	0	0	0	0	0	0	0	0	CH4	CH3	CH2	CH1

Data for b4 to b15 are fixed to "0".

1: Setting-target channel
0: Invalid

Point

- The settings for multiple channels can be configured at the same time. However, set either of Offset/gain setting mode Offset specification (Un\G22) or Offset/gain setting mode Gain specification (Un\G23) to be disabled (0).
When the settings for both of them are configured at the same time, a gain setting mode error (error code: 500) occurs.
- For details on offset/gain setting, refer to the following.
 - Offset/gain setting (Page 54, Section 7.5)

(9) Averaging process setting (Un\G24)

Configure the setting when selecting sampling or averaging processing for each channel.

Averaging processing includes time average, count average and moving average.

b15 to b12	b11 to b8	b7 to b4	b3 to b0
CH4	CH3	CH2	CH1

Processing method	Setting value
Sampling processing	0 _H
Time average	1 _H
Count average	2 _H
Moving average	3 _H

(a) Enabling the setting

Turn OFF → ON → OFF Operating condition setting request (Y9) to enable the setting.

(b) Default value

All channels are set to sampling (0) as the default value.

Point

- When using Averaging process setting (used to replace Q64AD) (Un\G9), the value set in Averaging process setting (Un\G24) is ignored. (The operation is performed in the averaging process setting in Averaging process setting (used to replace Q64AD) (Un\G9).)
- The channel to which a value out of the above setting range is written performs the operation in the sampling processing.

(10) Conversion speed setting (Un\G26)

Set the conversion speed for all channels.

When the value of 0003_H to FFFF_H is set, an error occurs and the operation is performed in the previous setting.

Conversion speed	Setting value
20μs	0 _H
80μs	1 _H
1ms	2 _H

(a) Enabling the setting

Turn OFF → ON → OFF Operating condition setting request (Y9) to enable the setting.

(b) Default value

80μs (1) is set as the default value.

(11) Input signal error detection extension setting (Un\G27)

In the input signal error detection extension function, set the error detection method for each channel. When Input signal error detection extension setting (Un\G27) is set to other than Disable (0), the input signal error detection extension function turns enabled.

For details on the input signal error detection extension function, refer to the following.

- Input signal error detection extension function (☞ Page 74, Section 8.8)

b15 to b12	b11 to b8	b7 to b4	b3 to b0
CH4	CH3	CH2	CH1

Detection method	Setting value
Disable	0 _H
Lower upper limit detection	1 _H
Lower limit detection	2 _H
Upper limit detection	3 _H
Disconnection detection	4 _H

(a) Enabling the setting

Turn OFF → ON → OFF Operating condition setting request (Y9) to enable the setting.

(b) Default value

All channels are set to Disable (0).

Point

- When a value out of the setting range above is set to a channel, an error occurs in the channel, an error code is stored in Latest error code (Un\G19) and Error flag (XF) is turned to ON. The operation is performed in the setting configured before the error occurrence.
- Disconnection detection (4) is valid only when the input range is set as 4 to 20mA (extended mode) or 1 to 5V (extended mode). When the channel with another range is set to Disconnection detection (4), an error occurs.
- When Input signal error detection extension setting (Un\G27) is set to Lower upper limit detection (1), Upper limit detection (2), Lower limit detection (3), or Disconnection detection (4), the setting of Input signal error detection setting (Un\G47) is ignored.

(12) Digital clipping enable/disable setting (Un\G29)

Set whether the digital clipping function is enabled or disabled, for each channel.

For details on the digital clipping function, refer to the following.

- Digital Clipping Function (👉 Page 90, Section 8.12)

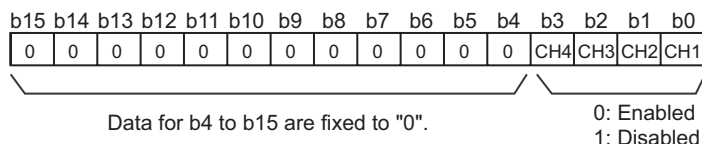

(a) Enabling the setting

Turn OFF → ON → OFF Operating condition setting request (Y9) to enable the setting.

(b) Default value

All channels are set to Disable (1).

(13) CH□ Maximum value (Un\G30, Un\G32, Un\G34, Un\G36), CH□ Minimum value (Un\G31, Un\G33, Un\G35, Un\G37)

The maximum and minimum values of converted digital output value are stored as signed 16-bit binary.

In the following cases, CH□ Maximum value (Un\G30, Un\G32, Un\G34, Un\G36) and CH□ Minimum value

(Un\G31, Un\G33, Un\G35, Un\G37) are updated with the current value.

- When turning OFF → ON → OFF Operating condition setting request (Y9) changes the setting
- When Maximum value/minimum value reset request (YD) is turned OFF → ON → OFF

Point

- For the channel to which the averaging processing is specified, the maximum and minimum values are stored at averaging processing time intervals.
- In CH□ Maximum value (Un\G30, Un\G32, Un\G34, Un\G36) and CH□ Minimum value (Un\G31, Un\G33, Un\G35, Un\G37), the values calculated by each function is stored using the following functions:
 - Digital clipping function
 - Scaling function
 - Shift function
 - Difference conversion function

(14) Input signal error detection setting (Un\G47)

Set whether the alarm output of input signal error detection is enabled or disabled for each channel. Only the lower upper limit detection can be used as the detection method of an input signal error in this area.

- Input Signal Error Detection Function (👉 Page 69, Section 8.7)

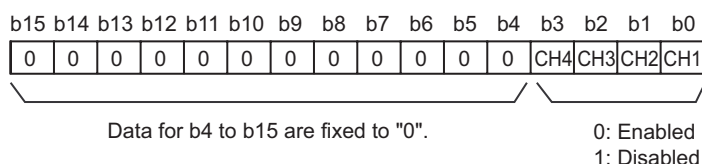

(a) Enabling the setting

Turn OFF → ON → OFF Operating condition setting request (Y9) to enable the setting.

(b) Default value

All channels are set to disable (1) as the default value.

Point

When Input signal error detection extension setting (Un\G27) is set to other than Disable (0), the setting in this area is ignored.

(15) Warning output setting (Un\G48)

Set whether the alarm output of process alarm is enabled or disabled for each channel.

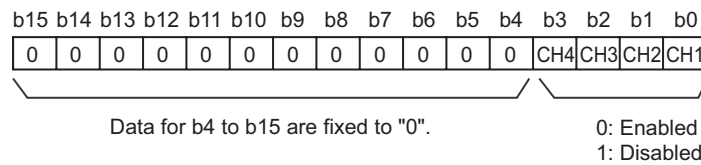

(a) Enabling the setting

Turn OFF → ON → OFF Operating condition setting request (Y9) to enable the setting.

(b) Default value

All channels are set to disable (1) as the default value.

(16) Input signal error detection flag (Un\G49)

Input signal status can be checked with this flag.

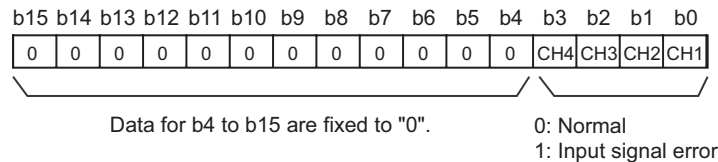

(a) Input signal error detection flag (Un\G49) status

- When setting the detection method in Input signal error detection extension setting (Un\G27)
When the analog input value out of the setting range for CH□ Input signal error detection setting value (Un\G142 to Un\G145) is detected according to the set condition of detection method, Input signal error detection flag (Un\G49) corresponding to each channel is turned to input signal error (1).
- When setting Input signal error detection setting (Un\G47) to Enable (0) and Input signal error detection extension setting (Un\G27) to Disable (0)
When the analog input value out of the setting range for CH□ Input signal error detection setting value (Un\G142 to Un\G145) is detected, Input signal error detection flag (Un\G49) corresponding to each channel is turned to input signal error (1).
- When an error is detected in any A/D conversion enable or input signal error detection enable channels, Input signal error detection signal (XC) is turned to ON.

(b) Clearing Input signal error detection flag (Un\G49)

Input signal error detection flag (Un\G49) can be cleared in the following two procedures.

- Turn OFF → ON → OFF Operating condition setting request (Y9)
- Turn OFF → ON → OFF Error clear request (YF)

(17)Warning output flag (Process alarm) (Un\G50)

Alarms can be checked if the alarm is the upper limit alarm or lower limit alarm, for each channel.

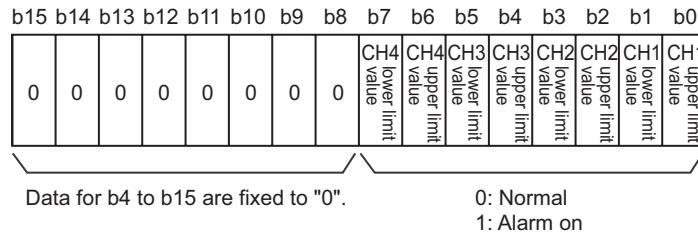

(a) Warning output flag (Process alarm) (Un\G50) status

- When the value is out of the range specified in CH1 Process alarm lower lower limit value (Un\G86) to CH4 Process alarm upper upper limit value (Un\G101), Warning output flag (Process alarm) (Un\G50) corresponding to each channel is turned to alarm ON (1).
- When an error is detected in any A/D conversion enable or alarm output enable channels, Warning output signal (X8) is also turned to ON.

(b) Clearing Warning output flag (Process alarm) (Un\G50)

- When the digital output value returns within the setting range, the flag is automatically cleared.
- When Operating condition setting request (Y9) is turned OFF → ON → OFF, it is cleared.

(18)Scaling enable/disable setting (Un\G53)

Set whether the scaling is enabled or disabled, for each channel.

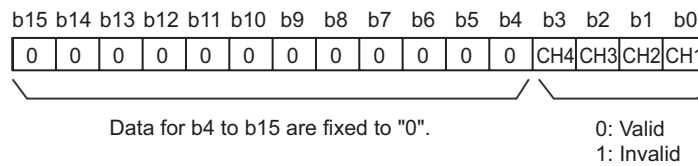

(a) Enabling the setting

Turn OFF → ON → OFF Operating condition setting request (Y9) to enable the setting.

(b) Default value

All channels are set to disable (1) as the default value.

A

Appendix 2 Details of Buffer Memory Addresses

(19)CH□ Scaling value (digital operation value) (Un\G54 to Un\G57)

The scaling value (digital operation value) which is obtained by the scaling function, shift function, digital clipping function, and difference conversion function is stored as signed 16-bit binary.

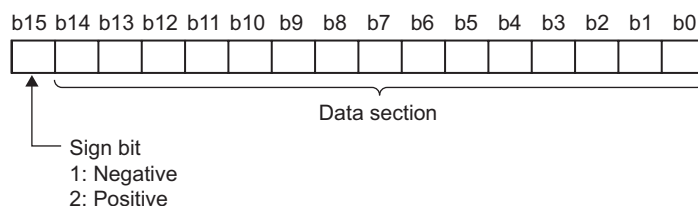

Point

When the digital clipping function, scaling function, shifting function, or difference conversion function is not used, the same value as the one in CH□ Digital output value (Un\G11 to Un\G14) is stored.

(20)CH□ Scaling lower limit value (Un\G62, Un\G64, Un\G66, Un\G68), CH□ Scaling upper limit value (Un\G63, Un\G65, Un\G67, Un\G69)

Set the range of scale conversion for each channel.

For details on scaling function, refer to the following.

- Scaling Function (☞ Page 80, Section 8.10)

(a) Setting range

Setting range: -32000 to 32000 (scaling upper limit value > scaling lower limit value)

(b) Enabling the setting

Turn OFF → ON → OFF Operating condition setting request (Y9) to enable the setting.

(c) Default value

All channels are set to 0.

Point

- When a value set to a channel is out of the setting range above or a value does not satisfy "scaling upper limit value > scaling lower limit value", an error occurs to the channel. Then, an error code is stored in Latest error code (Un\G19), Error flag (XF) is turned ON and the operation is performed in the setting configured before the error occurrence.
- Change the setting value, since 0 is set as the default value.
- When Scaling enable/disable setting (Un\G53) is set to Disable (1), the setting for CH□ Scaling lower limit value (Un\G62, Un\G64, Un\G66, Un\G68) and CH□ Scaling upper limit value (Un\G63, Un\G65, Un\G67, Un\G69) are ignored.

- (21)CH□ Process alarm lower lower limit value (Un\G86, Un\G90, Un\G94, Un\G98),
 CH□ Process alarm lower upper limit value (Un\G87, Un\G91, Un\G95, Un\G99),
 CH□ Process alarm upper lower limit value (Un\G88, Un\G92, Un\G96, Un\G100),
 CH□ Process alarm upper upper limit value (Un\G89, Un\G93, Un\G97, Un\G101)**

Set the digital output value range for each channel.

For details on warning output function (process alarm), refer to the following.

- Warning Output Function (Process Alarm) (👉 Page 77, Section 8.9)

(a) Setting range

- Setting range is -32768 to 32767.
- Configure the 4-step setting of process alarm upper upper limit value, process alarm upper lower limit value, process alarm lower upper limit value and process alarm lower lower limit value.

(b) Enabling the setting

Turn OFF → ON → OFF Operating condition setting request (Y9) to enable the setting.

(c) Default value

0 is set as the default value.

Point

- When a value out of the setting range above or a value which does not satisfy the formula of process alarm upper upper limit value \geq process alarm upper lower limit value \geq process alarm lower upper limit value \geq process alarm lower lower limit value is set to a channel, an error occurs in the channel. The error code is stored in Latest error code (Un\G19), and Error flag (XF) is turned to ON. The operation is performed in the setting configured before the error occurrence.
- Change the setting value, since 0 is set as the default value.
- When the following functions are used, warning targets are scaling values that reflect the operations of each function. Set values considering operation results of each function.
 - Digital clipping function
 - Scaling function
 - Shift function
 - Difference conversion function

(22)CH□ Input signal error detection setting value (Un\G142 to Un\G145)

Set the setting value to detect an input analog value error for each channel.

For details on the input signal error detection function and input signal error detection extension function, refer to the following.

- Input signal error detection function (☞ Page 69, Section 8.7)
- Input signal error detection extension function (☞ Page 74, Section 8.8)

(a) Setting procedure

- Setting range is 0 to 250 (0 to 25.0%). Set in increments of 1 (0.1%).
- The input signal error detection upper and lower limit values are calculated as follows based on the input signal error detection setting value. The calculating input signal error detection upper and lower limit values will be different depending on the input range to be used.

[Input signal error detection upper limit value]

$$= \text{Gain value of each range} + \left(\text{Gain value of each range} - \text{Offset value of each range} \right) \times \frac{\text{Input signal error detection setting value}}{1000}$$

[Input signal error detection lower limit value]

$$= \text{Lower limit value of each range} - \left(\text{Gain value of each range} - \text{Offset value of each range} \right) \times \frac{\text{Input signal error detection setting value}}{1000}$$

Ex. When the input signal error detection setting value is set to 100 (10%)
Range to be used: 4 to 20mA

The upper and lower limit values of input signal error detection are as follows:

$$\text{Input signal error detection upper limit value} = 20 + (20 - 4) \times \frac{100}{1000} = 21.6\text{mA}$$

$$\text{Input signal error detection lower limit value} = -4 - (20 - 4) \times \frac{100}{1000} = -2.4\text{mA}$$

- Conditions vary as follows depending on the setting in Input signal error detection extension setting (Un\G27).

Input signal error detection extension setting (Un\G27)	Detection condition
Lower upper limit detection (1)	At the input signal error detection upper limit value or the input signal error detection lower limit value
Lower limit detection (2)	At the input signal error detection lower limit value
Upper limit detection (3)	At the input signal error detection upper limit value
Disconnection detection (4)	<ul style="list-style-type: none"> • In 2mA or less, or 0.5V or less • The setting for CH□ Input signal error detection setting value (Un\G142 to Un\G145) is ignored. • Input range other than 4 to 20mA (extended mode) or 1 to 5V (extended mode) cannot be used.

(b) Enabling the setting

Turn OFF → ON → OFF Operating condition setting request (Y9) to enable the setting.

(c) Default value

All channels are set to 5% (50).

Point

When a value out of the setting range above is set to a channel, an error occurs in the channel, an error code is stored in Latest error code (Un\G19) and Error flag (XF) is turned ON. The operation is performed in the setting configured before the error occurrence.

(23)CH□ Shifting amount to conversion value (Un\G150 to Un\G153)

Set the shifting amount to conversion value that is to be used for the shift function.

For details on the shift function, refer to the following.

- Shift function (☞ Page 86, Section 8.11)

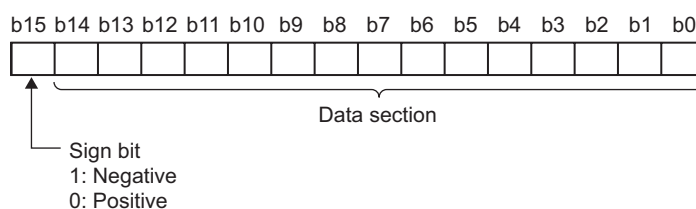

(a) Setting range

Setting range is -32768 to 32767.

(b) Enabling the setting

- When the value is set, set shifting amount to conversion value turns valid regardless of turning Operating condition setting request (Y9) OFF → ON → OFF.

(c) Default value

All channels are set to Disable (0).

(24)Mode switching setting (Un\G158, Un\G159)

Set the setting value for the mode to be switched to.

Mode switching to	Setting value	
	Un\G158	Un\G159
Normal mode	0964 _H	4144 _H
Offset/gain setting mode	4144 _H	0964 _H

(a) Enabling the setting

Turn OFF → ON → OFF Operating condition setting request (Y9) to enable the setting.

(b) After the mode is switched

When the mode is switched, this area is cleared to zero and Operating condition setting completed flag (X9) is turned to OFF.

After checking that the operating condition setting complete/completion flag is OFF, turn Operating condition setting request (Y9) to OFF

Point

When a value out of the setting range above is written, the mode is not switched and only the operating condition is changed.

(25)CH□ Difference conversion trigger (Un\G172 to Un\G175)

Use this buffer memory as a trigger to start/stop the difference conversion.

For details on the difference conversion function, refer to the following.

- Difference Conversion Function (☞ Page 94, Section 8.13)

Difference conversion trigger	Setting value
No request	0
Trigger request	1

(a) Starting/Stopping the difference conversion

- When the setting value is turned No request (0) → Trigger request (1), the difference conversion starts.
- When the setting value is turned Trigger request (0) → No request (1), the difference conversion stops.

(b) Default value

All channels are set to No request (0).

Point

In the channel where a setting value other than the above is set, an error occurs. The error code is stored in Latest error code (Un\G19) and Error flag (XF) turns on. However, the difference conversion continues.

(26)CH□ Difference conversion reference value (Un\G180 to Un\G183)

This is the area for storing the scaling value (digital operation value) at the start of the difference conversion as the difference conversion reference value.

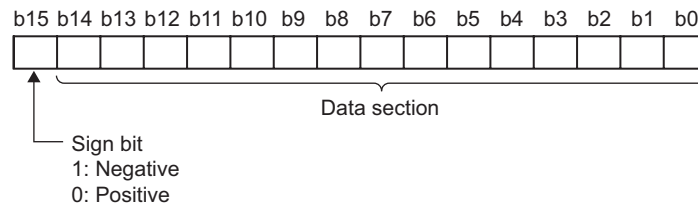

(a) Setting range

Setting range is -32768 to 32767.

Point

- The difference conversion reference value is updated when CH□ Difference conversion trigger (Un\G172 to Un\G175) is turned No request (0) → Trigger request (1).
- Even if CH□ Difference conversion status flag (Un\G190 to Un\G193) is turned Converting difference (1) → Not converted (0), CH□ Difference conversion reference value (Un\G180 to Un\G183) is not cleared.

(27)CH□ Difference conversion status flag (Un\G190 to Un\G193)

Difference conversion status can be checked with this flag.

Difference conversion status	CH□ Difference conversion status flag (Un\G190 to Un\G193)
Not converted	0
Converting difference	1

- When CH□ Difference conversion trigger (Un\G172 to Un\G175) is turned No request (0) → Requested (1), CH□ Difference conversion status flag (Un\G190 to Un\G193) is turned to Converting difference (1).
- When CH□ Difference conversion trigger (Un\G172 to Un\G175) is turned Requested (1) → No request (0), CH□ Difference conversion status flag (Un\G190 to Un\G193) is turned Converting difference (1) → Not converted (0).

(28)Pass data classification setting (Un\G200)

This is the area for saving and restoring the offset/gain setting value in user range setting.

Specify if the offset/gain setting value to be saved or restored is either voltage or current.

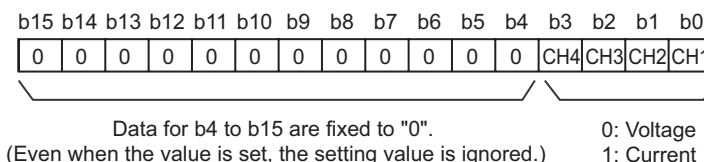
**(29)CH1 Industrial shipment settings offset value (L) (Un\G202) to CH4 User range settings gain value (H) (Un\G233)**

This is the area for restoring the offset/gain setting value in user range setting.

When the offset/gain setting of the user range setting is restored, the data to be used is stored with the following operation.

- Writing the initial setting by utility
- Turning OFF → ON Operating condition setting request (Y9) *1
- Turning OFF → ON User range write request (YA) (in offset/gain setting mode)

*1 The data is not saved when the setting value is written to Mode switching setting (Un\G158, Un\G159).

When restoring the offset/gain setting value in user range setting, set the data saved in this area to the same area in the A/D converter module where the data is restored.

For the setting procedure of offset/gain values or saving and restoring offset/gain values, refer to the following.

- Offset/gain setting (☞ Page 54, Section 7.5)
- Saving and restoring offset/gain values (☞ Page 124, Section 8.19)

(30)CH□ Logging enable/disable setting (Un\G1000 to Un\G1003)

Set whether the logging is enabled or disabled.

For details on the logging function, refer to the following.

- Logging function (☞ Page 98, Section 8.14)

Logging enable/disable setting	Setting value
Enable	0
Disable	1

(a) Enabling the setting

Turn OFF → ON → OFF Operating condition setting request (Y9) to enable the setting.

(b) Default value

All channels are set to Disable (1).

Point

- Enabling the setting starts the logging.
- In the channel where the following conditions are set, an error occurs. Then, the error code is stored in Latest error code (Un\G19), Error flag (XF) is turned to ON and logging cannot be performed.
 - When a value other than the above setting values is set
 - When Conversion speed setting (Un\G26) is set to 20μs (0) and CH□ Logging enable/disable setting (Un\G1000 to Un\G1003) is set to Enable (0)
 - When Input signal error detection setting (Un\G47) is set to Enable (0) and CH□ Logging enable/disable setting (Un\G1000 to Un\G1003) is set to Enable (0)
 - When Input signal error detection extension setting (Un\G27) is set to other than Disable (0) and CH□ Logging enable/disable setting (Un\G1000 to Un\G1003) is set to Enable (0)

(31)CH□ Logging hold request (Un\G1008 to Un\G1011)

Use Logging hold request (Un\G1008 to Un\G1011) as a trigger to hold (stop) the logging at any timing during the logging.

For details on the logging function, refer to the following.

- Logging function (☞ Page 98, Section 8.14)

Logging hold request	Setting value
OFF	0
ON	1

(a) Operation of the logging hold processing

- In the case that CH□ Level trigger condition setting (Un\G1056 to Un\G1059) is set to Disable (0), when CH□ Logging hold request (Un\G1008 to Un\G1011) changes from OFF (0) to ON (1), the logging hold processing starts.
- In the case that CH□ Level trigger condition setting (Un\G1056 to Un\G1059) is set to other than Disable (0), when the trigger condition is satisfied after CH□ Logging hold request (Un\G1008 to Un\G1011) changes from OFF (0) to ON (1), the logging hold processing starts.
When the level trigger is enabled, use Logging hold request (Un\G1008 to Un\G1011) as an interlock to operate the level trigger.
- If CH□ Logging hold request (Un\G1008 to Un\G1011) is turned to ON (1) → OFF (1), the hold status (stop) is cleared and the logging restarts.

(b) Default value

All channels are set to OFF (0).

Point

- In the channel where a value other than the above setting values is set, an error occurs. Then, the error code is stored in Latest error code (Un\G19) and Error flag (XF) is turned to ON. However, the logging continues.
- When CH□ Logging enable/disable setting (Un\G1000 to Un\G1003) is set to Disable (1), the setting for CH□ Logging hold request (Un\G1008 to Un\G1011) is ignored.

(32)CH□ Logging hold flag (Un\G1016 to Un\G1019)

Hold status of logging can be checked with this flag.

Hold status of logging	Stored value
OFF	0
ON	1

- Logging hold flag (Un\G1016 to Un\G1019) is turned to ON (1) when the status of logging changes to the hold (stop) from the status where the logging is recording data in the logging data storage area.

(33)CH□ Logging data setting (Un\G1024 to Un\G1027)

When the logging function is used, set whether the logging data type is Digital output value or Scaling value (digital operation value).

For details on the logging function, refer to the following.

- Logging function (👉 Page 98, Section 8.14)

Target of logging	Setting value
Digital output value	0
Scaling value (digital operation value)	1

(a) Enabling the setting

Turn OFF → ON → OFF Operating condition setting request (Y9) to enable the setting.

(b) Default value

All channels are set to Scaling value (digital operation value) (1).

Point

- In the channel where a value other than the above setting values is set, an error occurs. Then, the error code is stored in Latest error code (Un\G19), Error flag (XF) is turned to ON and the logging cannot be performed.
- When CH□ Logging enable/disable setting (Un\G1000 to Un\G1003) is set to Disable (1), the setting for CH□ Logging data setting (Un\G1024 to Un\G1027) is ignored.

(34) CH□ Logging cycle setting value (Un\G1032 to Un\G1035), CH□ Logging cycle unit setting (Un\G1040 to Un\G1043)

Set the cycle of storing the logging data.

Set a value for 1 cycle in CH□ Logging cycle setting value (Un\G1032 to Un\G1035).

Set a unit of cycle in CH□ Logging cycle unit setting (Un\G1040 to Un\G1043).

For details on the logging function, refer to the following.

- Logging function (☞ Page 98, Section 8.14)

(a) Setting range

The available setting range of CH□ Logging cycle setting value (Un\G1032 to Un\G1035) depends on the setting for CH□ Logging cycle unit setting (Un\G1040 to Un\G1043).

Logging cycle unit	Setting value of CH□ Logging cycle unit setting (Un\G1040 to Un\G1043)	Available setting range of CH□ Logging cycle setting value (Un\G1032 to Un\G1035)
μs	0	80 to 32767
ms	1	1 to 32767
s	2	1 to 3600

(b) Actual logging cycle

The actual logging cycle is an integral multiple of the conversion cycle of digital output value or scaling value (digital operation value).

Ex. When the conversion cycle is set to 80μs and the A/D conversion is performed for CH1 to CH3 with the sampling processing

→ The actual logging cycle is an integral multiple of 240μs (80μs × 3) with the value set in CH□ Logging cycle setting value (Un\G1032 to Un\G1035) and CH□ Logging cycle unit setting (Un\G1040 to Un\G1043) as the upper limit value.

(c) Enabling the setting

Turn OFF → ON → OFF Operating condition setting request (Y9) to enable the setting.

(d) Default value

- For CH□ Logging cycle setting value (Un\G1032 to Un\G1035), all channels are set to 4.
- For CH□ Logging cycle unit setting (Un\G1040 to Un\G1043), all channels are set to ms (1).

Point

- In the channel where the following conditions are set, an error occurs. Then, the error code is stored in Latest error code (Un\G19), Error flag (XF) is turned to ON and logging cannot be performed.
 - When a value out of the above setting range is set in either of CH□ Logging cycle setting value (Un\G1032 to Un\G1035) or CH□ Logging cycle unit setting (Un\G1040 to Un\G1043)
 - When the set logging cycle is below the update cycle of data to be logged
- When CH□ Logging enable/disable setting (Un\G1000 to Un\G1003) is set to Disable (1), the setting for CH□ Logging cycle setting value (Un\G1032 to Un\G1035) and CH□ Logging cycle unit setting (Un\G1040 to Un\G1043) are ignored.

(35) CH□ Logging points after trigger (Un\G1048 to Un\G1051)

When the logging function is used, set the data points recorded from hold trigger occurs until logging holds (stops).

For details on the logging function, refer to the following.

- Logging function (👉 Page 98, Section 8.14)

(a) Setting range

Setting range is 1 to 10000.

(b) Enabling the setting

Turn OFF → ON → OFF Operating condition setting request (Y9) to enable the setting.

(c) Default value

All channels are set to 5000.

Point/🔍

- In the channel where a value out of the above range is set, an error occurs. Then, the error code is stored in Latest error code (Un\G19), Error flag (XF) is turned to ON and logging cannot be performed.
- When CH□ Logging enable/disable setting (Un\G1000 to Un\G1003) is set to Disable (1), the setting for CH□ Logging points after trigger (Un\G1048 to Un\G1051) is ignored.

(36) CH□ Level trigger condition setting (Un\G1056 to Un\G1059)

When the level trigger is used with the logging function, set the occurrence condition of the hold trigger.

For details on the logging function, refer to the following.

- Logging function (👉 Page 98, Section 8.14)

Setting	Setting value
Disable	0
Above	1
Below	2
Pass through	3

(a) Enabling the setting

Turn OFF → ON → OFF Operating condition setting request (Y9) to enable the setting.

(b) Default value

All channels are set to Disable (0).

Point/🔍

- In the channel where a value other than the above setting values is set, an error occurs. Then, the error code is stored in Latest error code (Un\G19), Error flag (XF) is turned to ON and logging cannot be performed.
- When CH□ Logging enable/disable setting (Un\G1000 to Un\G1003) is set to Disable (1), the setting for CH□ Level trigger condition setting (Un\G1056 to Un\G1059) is ignored.

(37)CH□ Trigger data (Un\G1064 to Un\G1067)

When the logging function is used, set the buffer memory address monitored for the occurrence condition of level trigger.

For details on the logging function, refer to the following.

- Logging function (☞ Page 98, Section 8.14)

(a) Setting range

Setting range is 0 to 4999.

(b) Enabling the setting

Turn OFF → ON → OFF Operating condition setting request (Y9) to enable the setting.

(c) Default value

Channel	Default value	Buffer memory to be monitored
CH1	54	CH1 Scaling value (digital operation value) (Un\G54)
CH2	55	CH2 Scaling value (digital operation value) (Un\G55)
CH3	56	CH3 Scaling value (digital operation value) (Un\G56)
CH4	57	CH4 Scaling value (digital operation value) (Un\G57)

Point

- In the channel where a value out of the above setting range is set, an error occurs. Then, the error code is stored in Latest error code (Un\G19), Error flag (XF) is turned to ON and logging cannot be performed.
- Set CH□ Digital output value (Un\G11 to Un\G14), CH□ Scaling value (digital operation value) (Un\G54 to Un\G57), Level data □ (Un\G1072 to Un\G1081), or a buffer memory address with "R" in List of Buffer Memory Addresses to the trigger data.

Ex. Buffer memory address, system area, etc. with "R/W" or "W" in List of Buffer Memory Addresses

For details on the buffer memory address, refer to the following.

- List of buffer memory addresses (☞ Page 26, Section 3.5)

(38)Level data □ (Un\G1072 to Un\G1081)

This is the area for storing the data to be monitored when the level trigger of the logging function is used. 10 types of data are available: Level data 0 (Un\G1072) to Level data 9 (Un\G1081)

Use Level data □ (Un\G1072 to Un\G1081) to monitor device values in other than the A/D converter module and generate triggers.

- Logging function (☞ Page 98, Section 8.14)

(a) Application example

To monitor data register D100 in the CPU module and operate the level trigger in CH1, create a program as follows.

1. Set 1073 (Level data 1) for CH1 Trigger data (Un\G1064). (When Level data 1 is used)
2. Store the storage data which is D100 in the program in Level data 1 (Un\G1073) as needed. (The start I/O number is set to 10_H in the following program example.)



(b) Setting range

Setting range is -32768 to 32767.

(c) Default value

All are set to 0.

(39)CH□ Trigger setting value (Un\G1082 to Un\G1085)

When the logging function is used, set a level where a level trigger is generated.

For details on the logging function, refer to the following.

- Logging function (☞ Page 98, Section 8.14)

(a) Setting range

Setting range is -32768 to 32767.

(b) Enabling the setting

Turn OFF → ON → OFF Operating condition setting request (Y9) to enable the setting.

(c) Default value

All channels are set to 0.

(40)CH□ Head pointer (Un\G1090 to Un\G1093)

The buffer memory address where the oldest data is stored can be checked in CH□ Logging data (Un\G5000 to Un\G44999). The difference between the buffer memory address where the oldest data is stored and the start address in CH□ Logging data (Un\G5000 to Un\G44999) is stored.

Ex. When the value of CH2 Head pointer (Un\G1091) is 8551

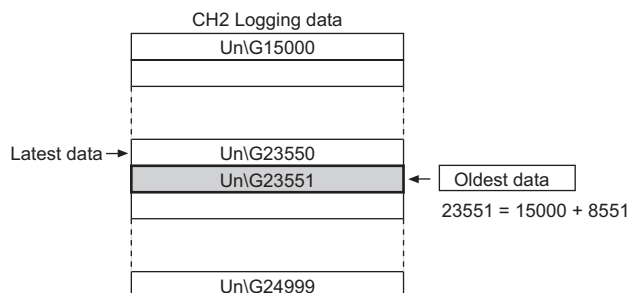
**Point**

- The value in CH□ Head pointer (Un\G1090 to Un\G1093) is fixed to 0 since the oldest data is stored in the start address of CH□ Logging data (Un\G5000 to Un\G44999) while the data of first 10000 points is logged from the logging is stated. After the 10001st data, the place of CH□ Latest pointer (Un\G1090 to Un\G1093) increases one by one.
- When CH□ Logging hold request (Un\G1008 to Un\G1011) is turned ON (1) → OFF (0), CH□ Head pointer (Un\G1090 to Un\G1093) is cleared to zero.

(41)CH□ Latest pointer (Un\G1098 to Un\G1101)

The buffer memory address where the latest data is stored can be checked in CH□ Logging data (Un\G5000 to Un\G44999). The difference between the buffer memory address where the latest data is stored and the start address in CH□ Logging data (Un\G5000 to Un\G44999) is stored.

Ex. When the value of CH2 Latest pointer (Un\G1099) is 8550

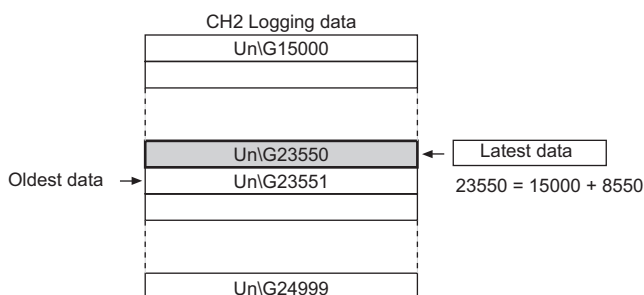
**Point**

- CH□ Latest pointer (Un\G1098 to Un\G1101) increases one by one each time data is stored from the logging starts.
- When CH□ Logging hold request (Un\G1008 to Un\G1011) is turned ON (1) → OFF (0), CH□ Latest pointer (Un\G1098 to Un\G1101) is cleared to zero.

(42)CH□ Number of logging data (Un\G1106 to Un\G1109)

The number of data stored in the logging data storage area can be checked during the logging.

Point

- The number of logging data increases one by one each time data is stored from the logging starts.
- When the value in the logging data storage area reaches 10000, CH□ Number of logging data (Un\G1106 to Un\G1109) is fixed to 10000 since the value is overwritten from the head again.
- When CH□ Logging hold request (Un\G1008 to Un\G1011) is turned ON (1) → OFF (0), CH□ Number of logging data (Un\G1106 to Un\G1109) is cleared to zero.

(43)CH□ Trigger pointer (Un\G1114 to Un\G1117)

The address of buffer memory which stores the data of when a hold trigger was executed can be checked in CH□ Logging data (Un\G5000 to Un\G44999).

The difference between the address of buffer memory which stores the data of when a hold trigger was executed and the start address in CH□ Logging data (Un\G5000 to Un\G44999) is stored.

Ex. When the value of CH2 Trigger pointer (Un\G1115) is 8550

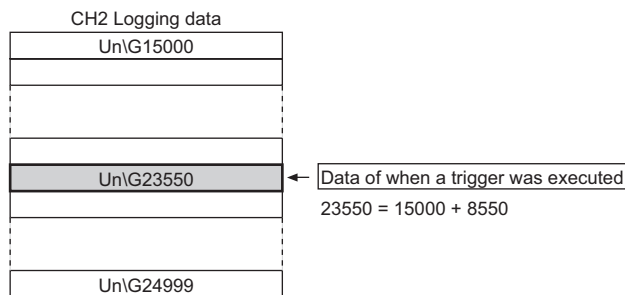

Point

- When CH□ Logging hold request (Un\G1008 to Un\G1011) is turned ON (1) → OFF (0), CH□ Trigger pointer (Un\G1114 to Un\G1117) is cleared to zero.

(44)CH□ Logging cycle monitor value (Un\G1122 to Un\G1133)

This is the area for storing the actual logging cycle which is calculated from the update cycle of data to be logged. When Operating condition setting request (Y9) is turned OFF → ON → OFF, the logging cycle is stored in CH□ Logging cycle monitor value (Un\G1122 to Un\G1133) in the corresponding channel where the logging function is enabled.

For details on the logging function, refer to the following.

- Logging function (👉 Page 98, Section 8.14)

	b15	to	b0
Un\G1122		s	
Un\G1123		ms	
Un\G1124		μs	

Ex. When the calculated value of logging cycle in CH1 is 6960μs

Buffer memory address	Stored value
Un\G1122	0 (s)
Un\G1123	6 (ms)
Un\G1124	960 (μs)

(45)CH□ Trigger detection time (Un\G1154 to Un\G1169)

The time that the hold trigger occurred is recorded.

	b15	to	b8	b7	to	b0
Un\G1154	First two digits of the year			Last two digits of the year		
Un\G1155	Month			Day		
Un\G1156	Hour			Minute		
Un\G1157	Second			Day of the week		

Item	Storage contents	Storage example ^{*1}
First two digits of the year/ Last two digits of the year	Stored in BCD code.	2011 _H
Month/Day		329 _H
Hour/Minute		1035 _H
Second		40 _H
Day of the week	One of the following values is stored for each day of the week in BCD code. <ul style="list-style-type: none"> • Sunday: 0 • Tuesday: 2 • Thursday: 4 • Saturday: 6 • Monday: 1 • Wednesday: 3 • Friday: 5 	2 _H

*1 Those are values when a hold trigger is detected at 10:35:40 on Tuesday, March 29th, 2011.

Point

- Time units shorter than one second are not recorded.
- When CH□ Logging hold request (Un\G1008 to Un\G1011) is turned ON (1) → OFF (0), CH□ Trigger detection time (Un\G1154 to Un\G1169) is cleared to zero.

(46)CH□ Flow amount integration enable/disable setting (Un\G1300 to Un\G1303)

Set whether the flow amount integration function is enabled or disabled.

For details on the flow amount integration function, refer to the following.

- Flow amount integration function (☞ Page 110, Section 8.15)

Flow amount integration enable/disable setting	Setting value
Enable	0
Disable	1

(a) Enabling the setting

Turn OFF → ON → OFF Operating condition setting request (Y9) to enable the setting.

(b) Default value

All channels are set to Disable (1).

Point

- In the channel where a setting value other than the above is set, an error occurs. The error code is stored in Latest error code (Un\G19) and Error flag (XF) is turned to ON.
- In the channel where the conversion speed is set to 20μs or 80μs and CH□ Flow amount integration enable/disable setting (Un\G1300 to Un\G1303) is Enabled (0), an error occurs. The error code is stored in Latest error code (Un\G19), Error flag (XF) is turned to ON, and the flow amount integration function is not enabled.

(47)CH□ Integration cycle setting (Un\G1308 to Un\G1311)

Set the integration cycle of flow amount integration in each channel.

For details on the flow amount integration function, refer to the following.

- Flow amount integration function (☞ Page 110, Section 8.15)

(a) Setting range

Setting range is 1 to 5000 (ms).

(b) Default value

All channels are set to 4 (ms).

Point

In the channel where the following conditions are set, an error occurs. Then, the error code is stored in Latest error code (Un\G19), Error flag (XF) is turned to ON and the flow amount integration function cannot be performed.

- When a value other than the above is set
- When the calculated integration cycle is below the data updated cycle of CH□ Scaling value (digital operation value) (Un\G54 to Un\G57)

(48)CH□ Flow amount time unit setting (Un\G1316 to Un\G1319)

Set a conversion value to convert the time unit of instantaneous flow amount to ms.

Set CH□ Flow amount time unit setting (Un\G1316 to Un\G1319) to the range of the flow meter connected to the A/D converter module.

For details on the flow amount integration function, refer to the following.

- Flow amount integration function (☞ Page 110, Section 8.15)

Flow amount time unit	Setting value
/s	0
/min	1
/h	2

Ex. When the range of the flow meter is "cm³/s", set / (0).

(a) Default value

All channels are set to /s (0).

Point!

In the channel where a setting value other than the above is set, an error occurs. The error code is stored in Latest error code (Un\G19), Error flag (XF) is turned to ON, and the flow amount integration function is not enabled.

(49)CH□ Unit scaling setting (Un\G1324 to Un\G1327)

Set the unit scaling that is used for the flow amount integration function.

For details on the flow amount integration function, refer to the following.

- Flow amount integration function (☞ Page 110, Section 8.15)

Unit scaling	Setting value
× 1	0
× 10	1
× 100	2
× 1000	3
× 10000	4

(a) Default value

All channels are set to × 1 (0).

Point!

In the channel where a setting value other than the above is set, an error occurs. The error code is stored in Latest error code (Un\G19), Error flag (XF) is turned to ON, and the flow amount integration function is not enabled.

(50)CH□ Integrated flow amount (Un\G1332 to Un\G1339)

This is the area for storing the result of the integral processing performed by the flow amount integration function. The integrated flow amount is stored with 32-bit signed binary.

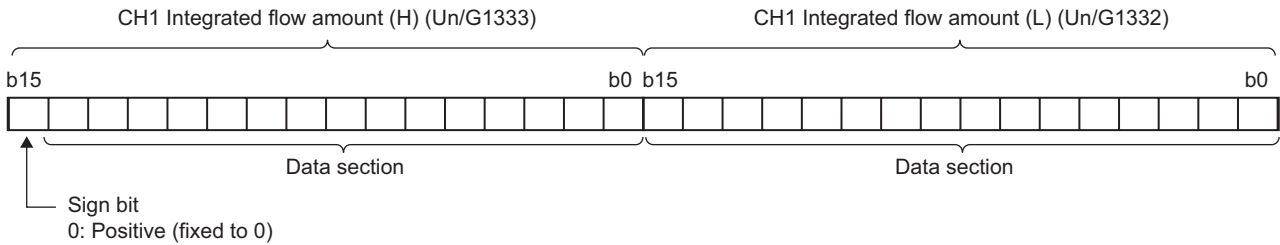

(a) Storage range

The value is stored within the range of 0 to 2147483647.

(51)CH□ Integration cycle monitor value (Un\G1348 to Un\G1351)

This is the area for storing the integration cycle which is calculated from the update cycle of CH□ Scaling value (digital operation value) (Un\G54 to Un\G57).

For details on the flow amount integration function, refer to the following.

- Flow amount integration function (☞ Page 110, Section 8.15)

(a) Storage range

When CH□ Flow amount integration enable/disable setting (Un\G1300 to Un\G1303) is Enable (0), the value is stored within the range of 1 to 5000. When it is Disable (1), the value is fixed to 0.

(52)CH□ Flow amount integration temporary stop request (Un\G1356 to Un\G1359)

Stops the integral processing temporarily while the flow amount integration function is operating.

For details on the flow amount integration function, refer to the following.

- Flow amount integration function (☞ Page 110, Section 8.15)

Flow amount integration temporary stop request	Setting value
No request	0
Temporary stop request	1

- When CH□ Flow amount integration temporary stop request (Un\G1356 to Un\G1359) is turned No request (0) → Temporary stop request (1) while the flow amount integration function is operating, the flow amount integration function temporarily stops.
- When CH□ Flow amount integration temporary stop request (Un\G1356 to Un\G1359) is turned Temporary stop request (1) → No request (0) while the flow amount integration function temporarily stops, the flow amount integration function restarts.

(a) Default value

All channels are set to No request (0).

Point

In the channel where a setting value other than the above is set, an error occurs. The error code is stored in Latest error code (Un\G19), Error flag (XF) is turned to ON, and the setting is ignored.

(53)CH□ Flow amount integration temporary stop flag (Un\G1364 to Un\G1367)

Flow amount integration temporary stop request status can be checked with this flag.

Flow amount integration temporary stop request status	Stored value
No temporary stop request	0
Temporary stopping	1

- While the flow amount integration function temporarily stops by CH□ Flow amount integration temporary stop request (Un\G1356 to Un\G1359) being turned No request (0) → Temporary stop request (1), CH□ Flow amount integration temporary stop flag (Un\G1364 to Un\G1367) is turned to Temporary stop request (1).
- When the flow amount integration function restarts by CH□ Flow amount integration temporary stop request (Un\G1356 to Un\G1359) being turned Temporary stop request (1) → No request (0), CH□ Flow amount integration temporary stop flag (Un\G1364 to Un\G1367) is turned to No temporary stop request (1).

(54)CH□ Integrated flow amount clear request (Un\G1372 to Un\G1375)

When the flow amount integration function is enabled, the value of CH□ Integrated flow amount (Un\G1332 to Un\G1339) can be cleared to zero.

For details on the flow amount integration function, refer to the following.

- Flow amount integration function (☞ Page 110, Section 8.15)

Integrated flow amount clear request	Setting value
No request	0
Clear request	1

When CH□ Integrated flow amount clear request (Un\G1372 to Un\G1375) is turned to No request (0) → Clear request (1) while the flow amount integration function is operating, the value of CH□ Integrated flow amount (Un\G1332 to Un\G1339) in the corresponding channel is cleared to zero.

(a) Default value

All channels are set to No request (0).

Point

In the channel where a setting value other than the above is set, an error occurs. The error code is stored in Latest error code (Un\G19), Error flag (XF) is turned to ON, and the value of CH□ Integrated flow amount (Un\G1332 to Un\G1339) is not cleared.

(55)CH□ Integrated flow amount clear flag (Un\G1380 to Un\G1383)

Integrated flow amount clear request status can be checked with this flag.

Integrated flow amount clear flag	Setting value
No clear request	0
Cleared	1

- When CH□ Integrated flow amount clear request (Un\G1372 to Un\G1375) is turned No request (0) → Clear request (1) and the value of CH□ Integrated flow amount (Un\G1332 to Un\G1339) is cleared, CH□ Integrated flow amount clear flag (Un\G1380 to Un\G1383) is turned to Cleared (1).
- When CH□ Integrated flow amount clear request (Un\G1372 to Un\G1375) is turned to Clear request (1) → No request (0), CH□ Integrated flow amount clear flag (Un\G1380 to Un\G1383) is turned to No clear request (0).

(56) Latest error code address (Un\G1800)

The latest address of error log is stored.

(57) Error history No.□ (Un\G1810 to Un\G1969)

Up to 16 errors occurred in the module are recorded.

	b15	to	b8	b7	to	b0
Un\G1810	Error code					
Un\G1811	First two digits of the year			Last two digits of the year		
Un\G1812	Month			Day		
Un\G1813	Hour			Minute		
Un\G1814	Second			Day of the week		
Un\G1815 to Un\G1819	System area					

Item	Storage contents	Storage example ^{*1}
First two digits of the year/ Last two digits of the year	Stored in BCD code.	2011 _H
Month/Day		329 _H
Hour/Minute		1035 _H
Second		40 _H
Day of the week	One of the following values is stored for each day of the week in BCD code. <ul style="list-style-type: none"> • Sunday: 0 • Tuesday: 2 • Thursday: 4 • Saturday: 6 • Monday: 1 • Wednesday: 3 • Friday: 5 	2 _H

*1 Those are values when an error occurs at 10:35:40 on Tuesday, March 29th, 2011.

(58) CH□ Logging data (Un\G5000 to Un\G44999)

This is an area for storing the logged data. Up to 10000 data can be stored per channel. After the 10001st data for CH□ Logging data (Un\G5000 to Un\G44999) for each channel, the logging is continued overwriting the data from the head.

For details on the logging function, refer to the following.

- Logging function (👉 Page 98, Section 8.14)

Point

- When Operating condition setting request (Y9) is turned OFF → ON → OFF, the logging data in all the channels are cleared.
- Even if CH□ Logging hold request (Un\G1008 to Un\G1011) is turned ON (1) → OFF (0) and the logging restarts, the logged data is not cleared to zero.

Appendix 3 I/O Conversion Characteristic of A/D Conversion

I/O conversion characteristic of A/D conversion means the slope of the line connected between the offset value and gain value when converting the analog signal (voltage or current input) from outside of programmable controller to digital value.

(1) Offset value

This is the analog input value (voltage or current) when the digital output value becomes 0.

(2) Gain value

This is the analog input value (voltage or current) when the digital output value becomes 20000.

A

(3) Voltage input characteristic

The following graph shows the voltage input characteristic.

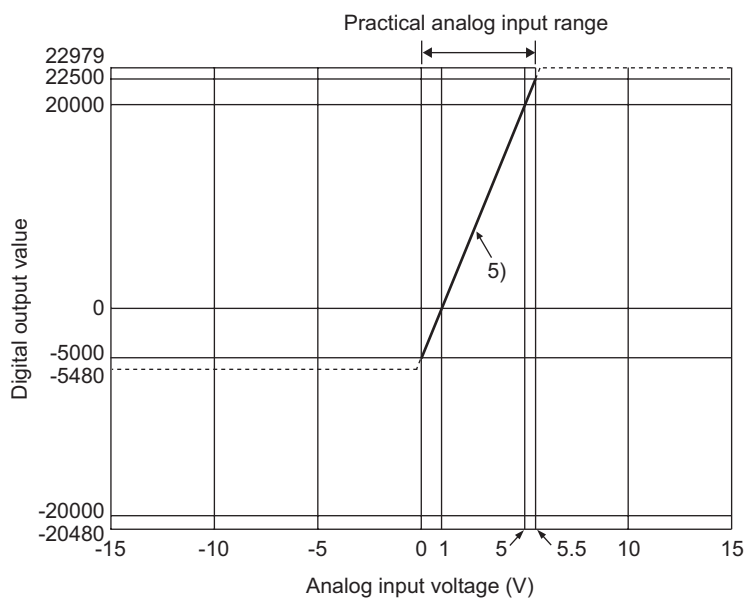
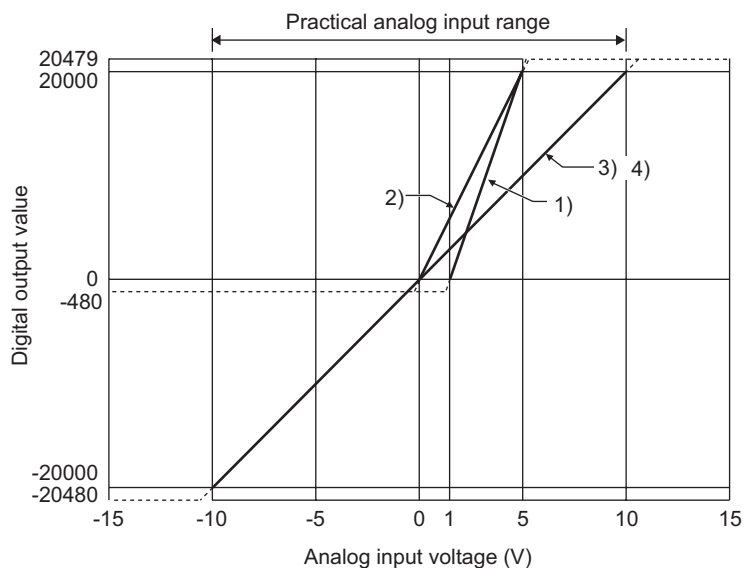

No.	Input range setting	Offset value	Gain value	Digital output value ^{*2}	Resolution
1)	1 to 5V	1V	5V	0 to 20000	200 μ V
2)	0 to 5V	0V	5V		250 μ V
3)	-10 to 10V	0V	10V	-20000 to 20000	500 μ V
4)	0 to 10V	0V	10V	0 to 20000	
5)	1 to 5V (Extended mode)	1V	5V	-5000 to 22500	200 μ V
—	User range setting	*1	*1	-20000 to 20000	307 μ V ^{*3}

- *1 Set the offset value and gain value in user range setting within the range satisfying the following conditions. If the following conditions are not satisfied, A/D conversion may not be properly performed.
- Setting range for offset value and gain value: -10 to 10V
 - $((\text{gain value}) - (\text{offset value})) \geq 4.0\text{V}$
- *2 When analog input is performed exceeding the range of digital output value, the digital output value is fixed to the maximum or minimum.

Input range setting	Digital output value	
	Minimum	Maximum
1 to 5V	-480	20479
0 to 5V		
-10 to 10V		
0 to 10V	-480	
1 to 5V (Extended mode)	-5480	22976
User range setting	-20480	20479

- *3 This is the maximum resolution in user range setting.

Point

- Use the value within the practical analog input range and practical digital output range. If a value is out of the range, the resolution and accuracy may not fall within the range of performance specifications. (Do not use the value in the dotted line region in the graph of voltage input characteristic.)
- Do not input a value of $\pm 15\text{V}$ or more. This may damage the elements.

(4) Current input characteristic

The following graph shows the current input characteristic.

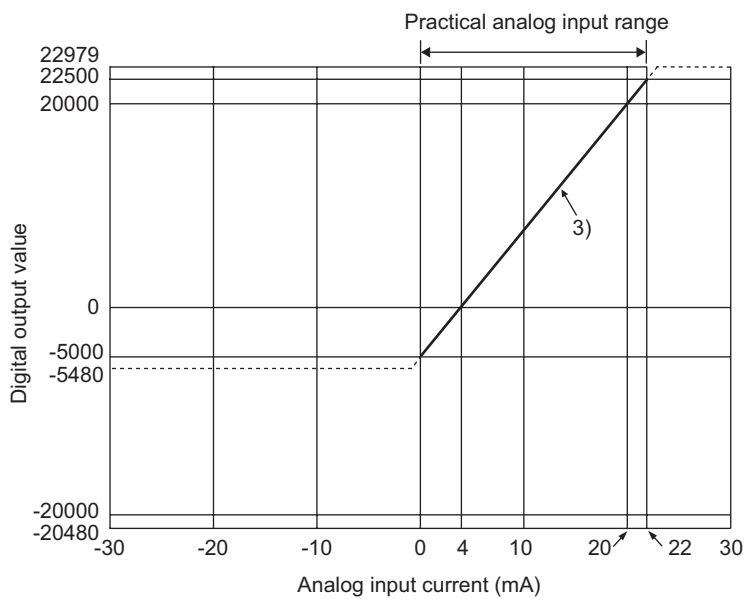
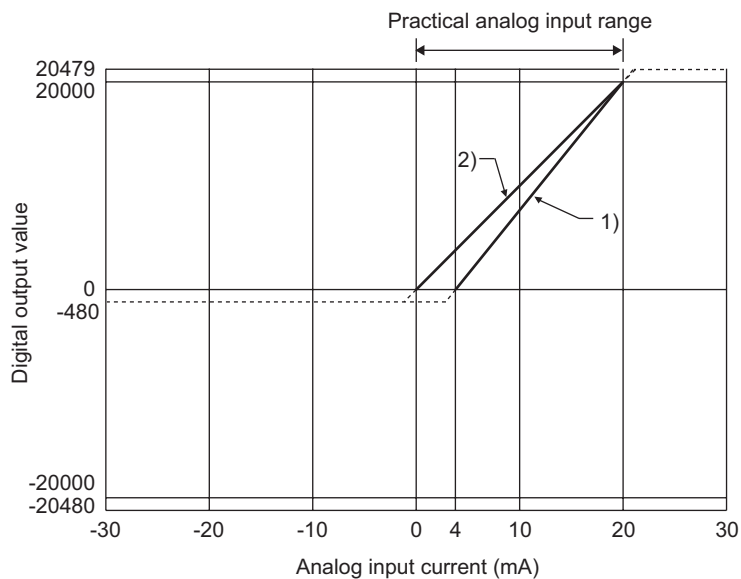

No.	Input range setting	Offset value	Gain value	Digital output value *2	Resolution
1)	4 to 20mA	4mA	20mA	0 to 20000	800nA
2)	0 to 20mA	0mA	20mA		1000nA
3)	4 to 20mA (Extended mode)	4mA	20mA	-5000 to 22500	800nA
—	User range setting	*1	*1	-20000 to 20000	1230nA *3

- *1 Set the offset value and gain value in the user range setting within the range satisfying the following conditions.
If the following conditions are not satisfied, A/D conversion may not be properly performed.
- gain value $\leq 20\text{mA}$, offset value $\geq 0\text{mA}$
 - ((gain value) - (offset value)) $\geq 16.0\text{mA}$
- *2 When analog input is performed exceeding the range of digital output value, the digital output value is fixed to the maximum or minimum.

Input range setting	Digital output value	
	Minimum	Maximum
4 to 20mA	-480	20479
0 to 20mA		
4 to 20mA (Extended mode)	-5480	22979
User range setting	-20480	20479

- *3 This is the maximum resolution in user range setting.

Point!

- Use the value within the practical analog input range and practical digital output range. If a value is out of the range, the resolution and accuracy may not fall within the range of performance specifications. (Do not use the value in the dotted line region in the graph of current input characteristic.)
- Do not input a value of $\pm 30\text{mA}$ or more. This may damage the elements.

Appendix 4 A/D Conversion Accuracy

The A/D conversion accuracy is the accuracy for the maximum value of digital output value.

Even when changing the offset/gain setting and input range to change the input characteristics, the accuracy does not change and is kept within the range of described performance specifications.

The following graph shows the fluctuation range of accuracy when the range of -10 to 10V is selected.

The accuracy is $\pm 0.1\%$ (± 20 digit) when the ambient temperature is $25 \pm 5^\circ\text{C}$ and $\pm 0.2\%$ (± 40 digit) when the ambient temperature is 0 to 55°C . (Excluding the case under noise effect.)

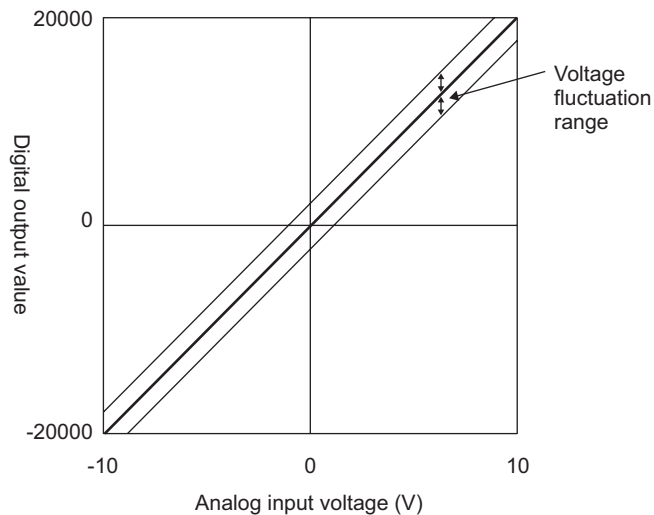

Appendix 5 Dedicated Instruction

This chapter describes the dedicated instructions that can be used in A/D converter module.

Appendix 5.1 Instruction list

The following shows the dedicated instructions that can be used in the A/D converter module.

Instruction	Description
G(P).OFFGAN	<ul style="list-style-type: none"> • The operation mode is changed to the offset/gain setting mode. • The operation mode is changed to the normal mode.
G(P).OGLoad	The offset/gain set value in the user range setting is read out to the CPU module.
G(P).OGSTOR	The offset/gain set value in the user range setting stored in the CPU module is restored to the A/D converter module.

A

Appendix 5.2 G(P).OFFGAN

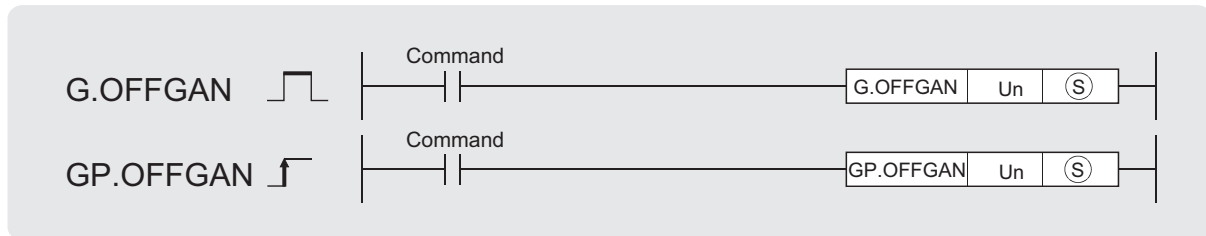

Setting data	Internal device		R, ZR	J□\□		U□\G□	Zn	Constant K, H, \$	Others
	Bit	Word		Bit	Word				
Ⓢ	—	○				—			

(1) Setting data

Device	Description	Setting range	Data type
Un	Start I/O number of module	0 to FE _H	BIN 16 bits
Ⓢ	Mode change 0: changed to the normal mode 1: changed to the offset/gain setting mode When a value other than above is set, the mode is changed to the offset/gain setting mode.	0, 1	BIN 16 bits

(2) Functions

This instruction switches the operation mode of the A/D converter module.

- Normal mode → offset/gain setting mode (Offset/gain setting mode flag (XA) is ON)
- Offset/gain setting mode → normal mode (Offset/gain setting mode flag (XA) is OFF)

Point

- When the mode is switched from the offset/gain setting mode to the normal mode, Module READY (X0) turns from OFF to ON.
Note that if a program includes the initial settings to be executed at ON of Module READY (X0), this instruction performs the initial setting process.
- When the mode is switched from the offset/gain setting mode to the normal mode, the A/D converter module operates under the previous operating condition.

(3) Errors

The instruction has no errors.

(4) Program example

The following shows the program of the A/D converter module, installed in I/O number X/Y10 to X/Y1F, with the following conditions:

- turning ON M10 switches the operation mode to the offset/gain setting mode, and
- turning OFF M10 restores the operation mode to the normal mode.

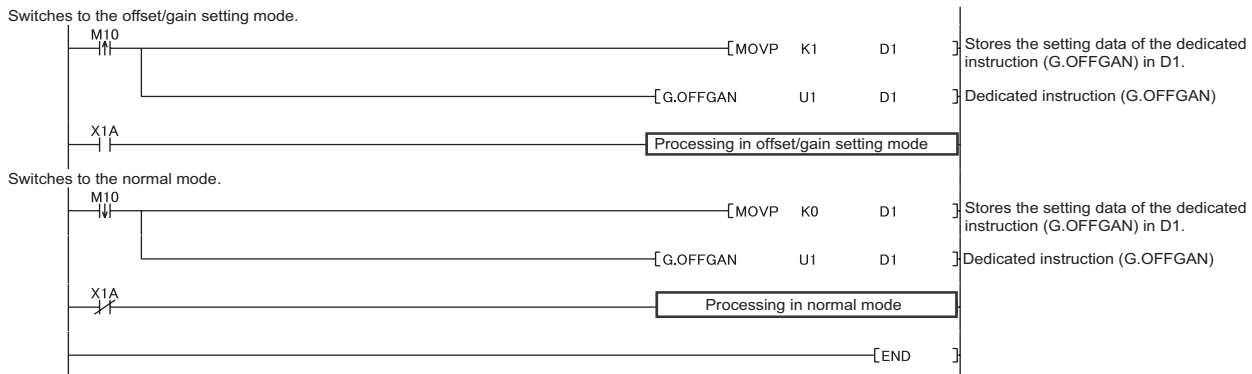

A

Appendix 5 Dedicated Instruction
Appendix 5.2 G(P).OFFGAN

Appendix 5.3 G(P).OGLOAD

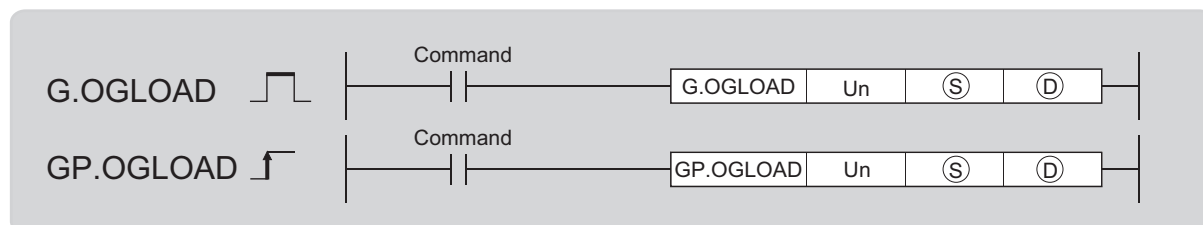

Setting data	Internal device		R, ZR	J□□		U□\G□	Zn	Constant K, H, \$	Others
	Bit	Word		Bit	Word				
Ⓢ	—	○				—			
ⓓ		○				—			

(1) Setting data

Device	Description	Setting range	Data type
Un	Start I/O number of module	0 to FE _H	BIN 16 bits
Ⓢ	Start number of device where the control data is stored	Within the range of specified device	Device name
ⓓ	Device which turns ON for one scan at the processing completion of the dedicated instruction. In error completion, ⓓ +1 also turns ON.	within the range of specified device	Bit

(2) Control data *1

Device	Item	Setting data	Setting range	Set by																				
Ⓢ	System area	—	—	—																				
Ⓢ+1	Completion status	The status on instruction completion is stored. 0 : normal completion Other than 0: error completion (error code)	—	System																				
Ⓢ+2	Pass data classification setting	Specify the type of offset/gain setting value to read out. 0: voltage 1: current <table border="1" style="margin-left: auto; margin-right: auto;"> <tr> <td>b15</td><td>b8</td><td>b7</td><td>b6</td><td>b5</td><td>b4</td><td>b3</td><td>b2</td><td>b1</td><td>b0</td> </tr> <tr> <td>0</td><td>~</td><td>~</td><td>~</td><td>~</td><td>0</td><td>CH4</td><td>CH3</td><td>CH2</td><td>CH1</td> </tr> </table>	b15	b8	b7	b6	b5	b4	b3	b2	b1	b0	0	~	~	~	~	0	CH4	CH3	CH2	CH1	0000 _H to 000F _H	User
b15	b8	b7	b6	b5	b4	b3	b2	b1	b0															
0	~	~	~	~	0	CH4	CH3	CH2	CH1															
Ⓢ+3	System area	—	—	—																				
Ⓢ+4	CH1 Industrial shipment settings offset value (L)	—	—	System																				
Ⓢ+5	CH1 Industrial shipment settings offset value (H)	—	—	System																				
Ⓢ+6	CH1 Industrial shipment settings gain value (L)	—	—	System																				
Ⓢ+7	CH1 Industrial shipment settings gain value (H)	—	—	System																				
Ⓢ+8	CH2 Industrial shipment settings offset value (L)	—	—	System																				
Ⓢ+9	CH2 Industrial shipment settings offset value (H)	—	—	System																				
Ⓢ+10	CH2 Industrial shipment settings gain value (L)	—	—	System																				
Ⓢ+11	CH2 Industrial shipment settings gain value (H)	—	—	System																				
Ⓢ+12	CH3 Industrial shipment settings offset value (L)	—	—	System																				
Ⓢ+13	CH3 Industrial shipment settings offset value (H)	—	—	System																				
Ⓢ+14	CH3 Industrial shipment settings gain value (L)	—	—	System																				
Ⓢ+15	CH3 Industrial shipment settings gain value (H)	—	—	System																				
Ⓢ+16	CH4 Industrial shipment settings offset value (L)	—	—	System																				
Ⓢ+17	CH4 Industrial shipment settings offset value (H)	—	—	System																				
Ⓢ+18	CH4 Industrial shipment settings gain value (L)	—	—	System																				
Ⓢ+19	CH4 Industrial shipment settings gain value (H)	—	—	System																				
Ⓢ+20	CH1 User range settings offset value (L)	—	—	System																				
Ⓢ+21	CH1 User range settings offset value (H)	—	—	System																				
Ⓢ+22	CH1 User range settings gain value (L)	—	—	System																				
Ⓢ+23	CH1 User range settings gain value (H)	—	—	System																				
Ⓢ+24	CH2 User range settings offset value (L)	—	—	System																				
Ⓢ+25	CH2 User range settings offset value (H)	—	—	System																				
Ⓢ+26	CH2 User range settings gain value (L)	—	—	System																				
Ⓢ+27	CH2 User range settings gain value (H)	—	—	System																				
Ⓢ+28	CH3 User range settings offset value (L)	—	—	System																				
Ⓢ+29	CH3 User range settings offset value (H)	—	—	System																				

A

Device	Item	Setting data	Setting range	Set by
Ⓢ+30	CH3 User range settings gain value (L)	—	—	System
Ⓢ+31	CH3 User range settings gain value (H)	—	—	System
Ⓢ+32	CH4 User range settings offset value (L)	—	—	System
Ⓢ+33	CH4 User range settings offset value (H)	—	—	System
Ⓢ+34	CH4 User range settings gain value (L)	—	—	System
Ⓢ+35	CH4 User range settings gain value (H)	—	—	System

*1 Configure the setting of Pass data classification setting Ⓢ +2 only.
When the data is written to the area to be set by system, offset/gain setting value is not correctly read out.

(3) Functions

- This instruction reads out the offset/gain set value in the user range setting of the A/D converter module to the CPU module.
- The interlock signal of G(P).OGLOAD includes a completion device Ⓣ and a completion status indication device Ⓣ+1.

(a) Completion device

The device turns ON at the END processing for the scan where the G(P).OGLOAD instruction is completed, and turns OFF at the next END processing.

(b) Completion status indication device

This device turns OFF → ON → OFF depending on the status of the G(P).OGLOAD instruction completion.

- Normal completion: the device is kept to be OFF.
- Error completion: the device turns ON at the END processing for the scan where the G(P).OGLOAD instruction is completed, and turns OFF at the next END processing.

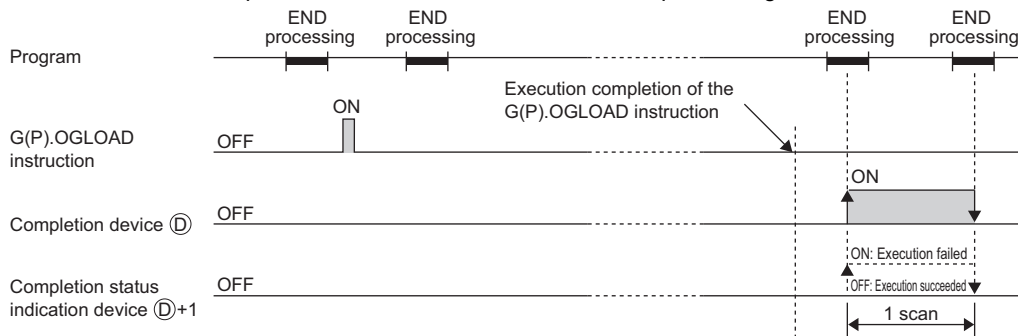

(4) Errors

The instruction has no errors.

(5) Program example

The following shows the program to read out the offset/gain setting value of the A/D converter module, installed in I/O number X/Y10 to X/Y1F, by turning ON M11.

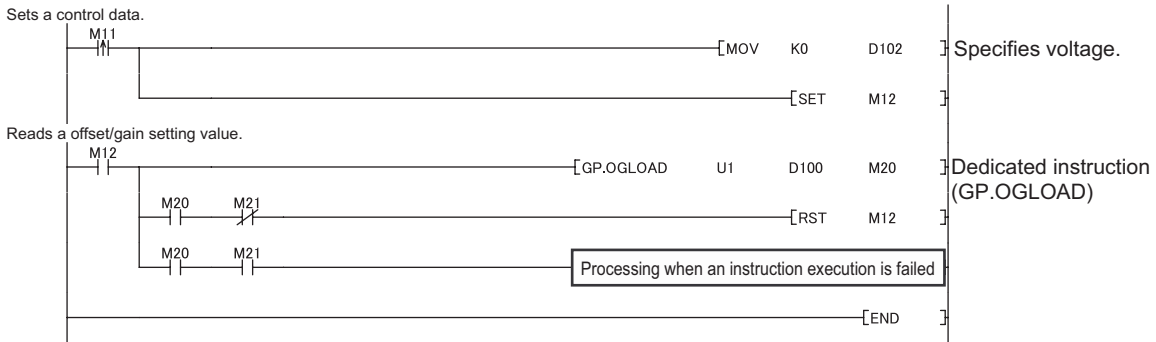

Appendix 5.4 G(P).OGSTOR

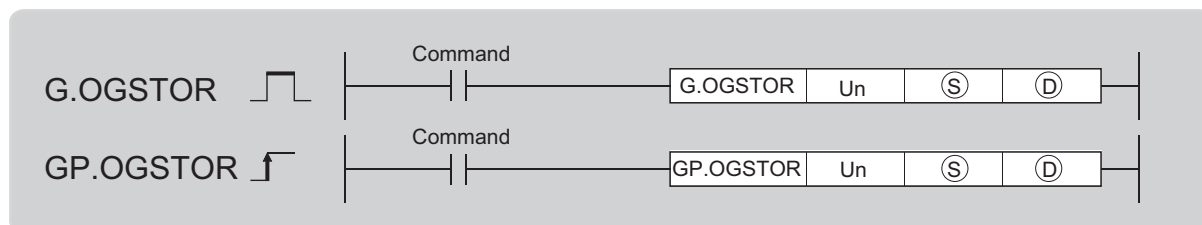

Setting data	Internal device		R, ZR	J□□		U□\G□	Zn	Constant K, H, \$	Others
	Bit	Word		Bit	Word				
Ⓢ	—	○				—			
ⓓ		○				—			

(1) Setting data

Device	Description	Setting range	Data type
Un	Start I/O number of module	0 to FE _H	BIN 16 bits
Ⓢ*1	Start number of device where the control data is stored	Within the range of specified device	Device name
ⓓ	Device which turns ON for one scan at the processing completion of the dedicated instruction. In error completion, ⓓ+1 also turns ON.	Within the range of specified device	Bit

- *1 Specify the device specified to Ⓢ on execution of the G(P).OGLOAD instruction. Do not change the data which is read out by the G(P).OGLOAD instruction. If the data is changed, the normal operation may not be ensured.

(2) Control data

Device	Item	Setting data	Setting range	Set by																				
Ⓢ	System area	—	—	—																				
Ⓢ+1	Completion status	The status on instruction completion is stored. 0 : normal completion Other than 0: error completion (error code)	—	System																				
Ⓢ+2	Pass data classification setting	The value which is set for Pass data classification setting Ⓢ +2 by G(P).OGLOAD instruction is stored. 0: voltage 1: current <table border="1" style="margin-left: auto; margin-right: auto;"> <tr> <td>b15</td><td>b8</td><td>b7</td><td>b6</td><td>b5</td><td>b4</td><td>b3</td><td>b2</td><td>b1</td><td>b0</td> </tr> <tr> <td>0</td><td>~</td><td>~</td><td>~</td><td>~</td><td>0</td><td>CH4</td><td>CH3</td><td>CH2</td><td>CH1</td> </tr> </table>	b15	b8	b7	b6	b5	b4	b3	b2	b1	b0	0	~	~	~	~	0	CH4	CH3	CH2	CH1	0000 _H to 000F _H	System
b15	b8	b7	b6	b5	b4	b3	b2	b1	b0															
0	~	~	~	~	0	CH4	CH3	CH2	CH1															
Ⓢ+3	System area	—	—	—																				
Ⓢ+4	CH1 Industrial shipment settings offset value (L)	—	—	System																				
Ⓢ+5	CH1 Industrial shipment settings offset value (H)	—	—	System																				
Ⓢ+6	CH1 Industrial shipment settings gain value (L)	—	—	System																				
Ⓢ+7	CH1 Industrial shipment settings gain value (H)	—	—	System																				
Ⓢ+8	CH2 Industrial shipment settings offset value (L)	—	—	System																				
Ⓢ+9	CH2 Industrial shipment settings offset value (H)	—	—	System																				
Ⓢ+10	CH2 Industrial shipment settings gain value (L)	—	—	System																				
Ⓢ+11	CH2 Industrial shipment settings gain value (H)	—	—	System																				
Ⓢ+12	CH3 Industrial shipment settings offset value (L)	—	—	System																				
Ⓢ+13	CH3 Industrial shipment settings offset value (H)	—	—	System																				
Ⓢ+14	CH3 Industrial shipment settings gain value (L)	—	—	System																				
Ⓢ+15	CH3 Industrial shipment settings gain value (H)	—	—	System																				
Ⓢ+16	CH4 Industrial shipment settings offset value (L)	—	—	System																				
Ⓢ+17	CH4 Industrial shipment settings offset value (H)	—	—	System																				
Ⓢ+18	CH4 Industrial shipment settings gain value (L)	—	—	System																				
Ⓢ+19	CH4 Industrial shipment settings gain value (H)	—	—	System																				
Ⓢ+20	CH1 User range settings offset value (L)	—	—	System																				
Ⓢ+21	CH1 User range settings offset value (H)	—	—	System																				
Ⓢ+22	CH1 User range settings gain value (L)	—	—	System																				
Ⓢ+23	CH1 User range settings gain value (H)	—	—	System																				
Ⓢ+24	CH2 User range settings offset value (L)	—	—	System																				
Ⓢ+25	CH2 User range settings offset value (H)	—	—	System																				
Ⓢ+26	CH2 User range settings gain value (L)	—	—	System																				
Ⓢ+27	CH2 User range settings gain value (H)	—	—	System																				
Ⓢ+28	CH3 User range settings offset value (L)	—	—	System																				

A

Device	Item	Setting data	Setting range	Set by
Ⓢ+29	CH3 User range settings offset value (H)	—	—	System
Ⓢ+30	CH3 User range settings gain value (L)	—	—	System
Ⓢ+31	CH3 User range settings gain value (H)	—	—	System
Ⓢ+32	CH4 User range settings offset value (L)	—	—	System
Ⓢ+33	CH4 User range settings offset value (H)	—	—	System
Ⓢ+34	CH4 User range settings gain value (L)	—	—	System
Ⓢ+35	CH4 User range settings gain value (H)	—	—	System

(3) Functions

- The offset/gain set value in user range setting stored in CPU module is restored to A/D converter module.
- There are two interlock signals of G(P).OGSTOR: a completion device Ⓣ and a completion status indication device Ⓣ+1.
- The reference accuracy on restoration of offset/gain setting value is lowered three times or less of that of before the restoration.

(a) Completion device

The device turns ON at the END processing for the scan where the G(P).OGSTOR instruction is completed, and turns OFF at the next END processing.

(b) Completion status indication device

This device turns OFF → ON → OFF depending on the status of the G(P).OGSTOR instruction completion.

- Normal completion: the device is kept to be OFF.
- Error completion: the device turns ON at the END processing for the scan where the G(P).OGSTOR instruction is completed, and turns OFF at the next END processing.

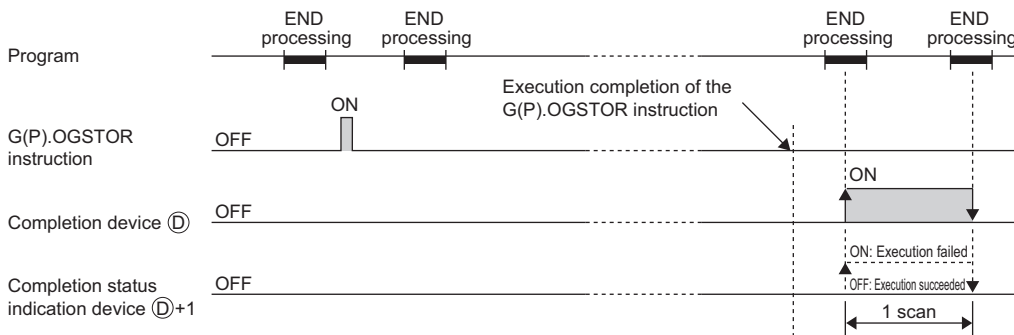

(4) Errors

In the following cases, an error occurs and error code is stored in completion status area Ⓢ +1.

Error code	Description of operation error
161	G(P).OGSTOR instruction is executed in offset/gain setting mode.
162	G(P).OGSTOR instruction is continuously executed.
163	<ul style="list-style-type: none"> • G(P).OGSTOR instruction is executed to the different model from the one to which G(P).OGLOAD instruction is executed. • G(P).OGSTOR instruction has been executed before the execution of G(P).OGLOAD instruction.

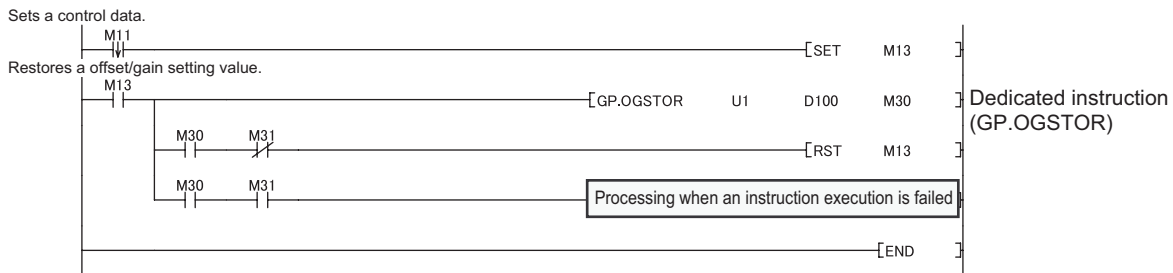

(5) Program example

The following shows the programs to write the offset/gain setting value to A/D converter module, installed in I/O number X/Y10 to X/Y1F, by turning OFF M11.



Appendix 6 Checking Serial Number and Function Version

For details on how to check the serial number and function version, refer to the following.

-  MELSEC-L CPU Module User's Manual (Hardware Design, Maintenance and Inspection)
-  MELSEC-L CC-Link IE Field Network Head Module User's Manual

Appendix 7 Addition and Change of Functions

Appendix 7.1 Addition of functions

The following table lists functions added to the A/D converter module and GX Works2, and product information of compatible A/D converter module and software version of GX Works2.

Added contents		Upper 5 digits of product information compatible with the A/D converter module	Compatible version of GX Works2	Reference
Input range extended mode function		13041 or later	1.62Q or later	Page 67, Section 8.4
Input signal error detection extension function				Page 74, Section 8.8
Shift function				Page 86, Section 8.11
Digital clipping function				Page 90, Section 8.12
Difference conversion function				Page 94, Section 8.13
Logging function				Page 98, Section 8.14
Flow amount integration function				Page 110, Section 8.15
Display unit	SHIFT screen			Page 136, Section 9.3 (7)
	DIGITALCLIP screen			Page 136, Section 9.3 (8)
	INPUT SIG ENH screen			Page 136, Section 9.3 (9)

Appendix 7.2 Change of functions

The following table lists functions changed in A/D converter module and GX Works2, and product information of compatible A/D converter module and software version of GX Works2.

Changed contents	Upper 5 digits of product information compatible with the A/D converter module	Compatible version of GX Works2	Reference
CH□ Scaling value (digital operation value) (Un\G54 to Un\G57)	13041 or later	1.62Q or later	Page 221, Appendix 7.2(1)
Maximum value/minimum value hold function			Page 221, Appendix 7.2(2)
Input signal error detection function			Page 221, Appendix 7.2(3)
Warning output function (Process alarm)			Page 221, Appendix 7.2(4)
Scaling function			Page 222, Appendix 7.2(5)

(1) CH□ Scaling value (digital operation value) (Un\G54 to Un\G57)

When the digital clipping function, scaling function, shift function, or difference conversion function is not used, the same value as the one in CH□ Digital output value (Un\G11 to Un\G14) is stored.

(a) When the non-compatible version of A/D converter module is used

When the scaling function is not used, the value is not stored in CH□ Scaling value (digital operation value) (Un\G54 to Un\G57).

(2) Maximum value/minimum value hold function

The scaling value (digital operation value) is stored in CH□ Maximum value (Un\G30, Un\G32, Un\G34, Un\G36) and CH□ Minimum value (Un\G31, Un\G33, Un\G35, Un\G37).

For details on the function, refer to the following.

- Maximum value/minimum value hold function (☞ Page 68, Section 8.6)

(a) When the non-compatible version of A/D converter module is used

When the scaling function is not used, the digital output value is stored in CH□ Maximum value (Un\G30, Un\G32, Un\G34, Un\G36) and CH□ Minimum value (Un\G31, Un\G33, Un\G35, Un\G37). When the scaling function is used, the scaling value (digital operation value) is stored in CH□ Maximum value (Un\G30, Un\G32, Un\G34, Un\G36) and CH□ Minimum value (Un\G31, Un\G33, Un\G35, Un\G37).

(3) Input signal error detection function

The detection cycle is changed to the sampling cycle.

For details on the function, refer to the following.

- Input signal error detection function (☞ Page 69, Section 8.7)

(a) When the non-compatible version of A/D converter module is used

The detection cycle is detected per sampling cycle or averaging process cycle depending on the specified A/D conversion method.

(4) Warning output function (Process alarm)

The alarm output function monitors CH□ Scaling value (digital operation value) (Un\G54 to Un\G57) for alarm output and does not monitor CH□ Digital output value (Un\G11 to Un\G14) for alarm output.

For details on the function, refer to the following.

- Warning output function (Process alarm) (☞ Page 77, Section 8.9)

(a) When the non-compatible version of A/D converter module is used

When the scaling function is not used, the alarm output function monitors CH□ Digital output value (Un\G11 to Un\G14) for alarm output. When the scaling function is used, the alarm output function monitors CH□ Scaling value (digital operation value) (Un\G54 to Un\G57) for alarm output.

(5) Scaling function

The scaling function can be used in a channel in which the user range setting is used.

For details on the function, refer to the following.

- Scaling function ( Page 77, Section 8.9)

(a) When the non-compatible version of A/D converter module is used

For the A/D converter module of non-compatible version, when the scaling function is set to be enabled in a channel in which the user range setting is used, an error occurs (error code: 99□). After the error occurrence, the error code is stored in Latest error code (Un\G19) and Error flag (XF) is turned to ON. The scaling function performs in the setting before the error.

For details on how to resolve the error, refer to the following.

- Error code list ( Page 159, Section 11.4)

Appendix 8 Differences with Q Series

The following describes the differences between L series and Q series, and the precautions for configuring the L-series system using the Q-series program.

The description in this chapter is in the case of Q64AD.

(1) Specification comparison

The following table shows a comparison of the specifications between the L60AD4 and Q64AD.

Difference	L60AD4	Q64AD
Resolution change function	1 type; 1/20000 (resolution change function is not installed)	2 types; normal resolution (1/4000) and high resolution (1/12000 or 1/16000)
Average time	20 μ s: 2 to 1500ms 80 μ s, 1ms: 2 to 5000ms	2 to 5000ms
Averaging process specification	Averaging process setting (used to replace Q64AD) (Un\G9) Averaging process setting (Un\G24)	Averaging process setting (used to replace Q64AD) (Un\G9)
Intelligent function module switch setting	<p>Fixed to 000H</p> <p>0H : Normal resolution mode 1H to FH (A value other than 0H) : High resolution mode</p>	<p>00H : With temperature drift correction 01H to FFH (value other than 00H) : Without temperature drift correction</p> <p>0H : Normal Resolution Mode 1H to FH (value other than 0H) : High resolution mode</p> <p>0H : Normal Resolution Mode (A/D conversion processing) 1H to FH (value other than 0H) : Offset/gain setting mode</p>
Digital output value, scaling value	When Operating condition setting request (Y9) is turned from OFF to ON, digital values and scaling values are held.	When Operating condition setting request (Y9) is turned from OFF to ON, digital values are cleared. (Q64AD has no scaling value.)

A

Appendix 8.1 Precautions for Applying Q Series Sequence Program

The initial setting program of a Q-series A/D converter module is applicable to the program of the L60AD4 for the input signals and the buffer memory assignment of the L60AD4 are compatible between the L60AD4 and Q64AD. The resolution is also applicable with the use of the module scaling function.

(1) Input signals and assignment of buffer memory

Refer to the following table to change the program.

Note the precautions for averaging process specification of channel isolated A/D converter modules (Q64AD-GH, Q68AD-G, Q66AD-DG).

The following shows the applicable module list.

Module		Averaging process specification	Description of application
Applied from	Applied to	Applied from	
Q64AD	L60AD4	Sampling Averaging process Count average (Setting: Un\G9)	Applicable without making any change. • Precaution Apply the sequence program with the conversion speed setting of 80μs.
Q68ADV/Q68ADI		Sampling Averaging process Count average (Setting: Un\G9)	Applicable without making any change. • Precaution Apply the sequence program with the conversion speed setting of 80μs.
Q62AD-DGH /Q64AD-GH		Sampling Averaging process Count average Moving average First-order delay filter (Setting: Un\G9)	Partial changes in the sequence program are required. Set the data in the buffer memory address (Un\G9) in the applying sequence program to the buffer memory address (Un\G24) of the applied sequence program. (If the first-order delay filter is set in the buffer memory address (Un\G9), set the other averaging processing to the buffer memory address (Un\G24).) • Precaution Set 0 to the buffer memory address (Un\G9) of the module.
Q68AD-G		Sampling Averaging process Count average Moving average First-order delay filter (Setting: Un\G24)	Applicable without making any change. (If the first-order delay filter is set in the buffer memory address (Un\G9), set the other averaging processing to the buffer memory address (Un\G24).) • Precaution Set 0 to the buffer memory address (Un\G9) of the module.
Q66AD-DG		Sampling Averaging process Count average Moving average First-order delay filter (Setting: Un\G24)	Applicable without making any change. (If the first-order delay filter is set in the buffer memory address (Un\G9), set the other averaging processing to the buffer memory address (Un\G24).) • Precaution Set 0 to the buffer memory address (Un\G9) of the module.

Point

- For details on the averaging process specification of the L-series A/D converter module, refer to the following.
Detail of buffer memory (☞ Page 174, Appendix 2)
- For details on averaging process specification of Q-series A/D converter modules, refer to the user's manual for each module.

(2) Resolution

Since the module has 1/20000 resolution, the program can be applied from Q-series A/D converter modules just by using the scaling function.

Note that it is the prior condition of the sequence program, applied from a channel isolated A/D converter module (Q68AD-G or Q66AD-DG), does not have the scaling function program.

When applying the sequence program, having the scaling function, from a channel isolated A/D converter module (Q68AD-G or Q66AD-DG), set the scaling upper and lower limit value corresponding to the setting in the sequence program applied from.

The following shows the scaling function setting when applying the sequence program from a Q-series A/D converter module.

Resolution of applied module	Resolution							
	1/4000		1/12000		1/16000		1/32000	
	Digital output value		Digital output value		Digital output value		Digital output value	
	0 to 4000	-4000 to 4000	0 to 12000	-12000 to 12000	0 to 16000	-16000 to 16000	0 to 32000	-32000 to 32000
Scaling upper limit value	4000	4000	12000	12000	16000	16000	32000	32000
Scaling lower limit value	0	-4000	0	-12000	0	-16000	0	-32000
Target module	Q64AD Q68ADV Q68ADI Q68AD-G Q66AD-DG		Q64AD Q68ADV Q68ADI Q68AD-G Q66AD-DG		Q64AD Q68ADV Q68ADI Q68AD-G Q66AD-DG		Q64AD-GH Q62AD-DGH (16 bit)	Q64AD-GH (16 bit)

Applying the sequence program of the Q64AD-GH or Q62AD-DGH with 1/64000 resolution by using the scaling function is not available.

Change the digital output value ranges in the program.

A

Appendix 9 When Using GX Developer or GX Configurator-AD

Appendix 9 describes the operating procedure when using GX Developer and GX Configurator-AD.

(1) Compatible software version

For compatible software version, refer to the following.

 MELSEC-L CPU Module User's Manual (Hardware Design, Maintenance and Inspection)

Appendix 9.1 Operation of GX Developer

Configure the setting on the following screen when using GX Developer.

Screen name	Application	Reference
I/O assignment	Set the type of module to be installed and the range of I/O signal.	Page 226, Appendix 9.1(1)
Switch setting	Configure the switch setting of an intelligent function module.	Page 227, Appendix 9.1(2)
Offset/gain setting	Configure the setting when using the user range setting for the input range.	Page 57, Section 7.5.2

(1) I/O assignment

Configure the setting from "I/O assignment" in "PLC parameter".

 Parameter ⇨ [PLC parameter] ⇨ [I/O assignment]

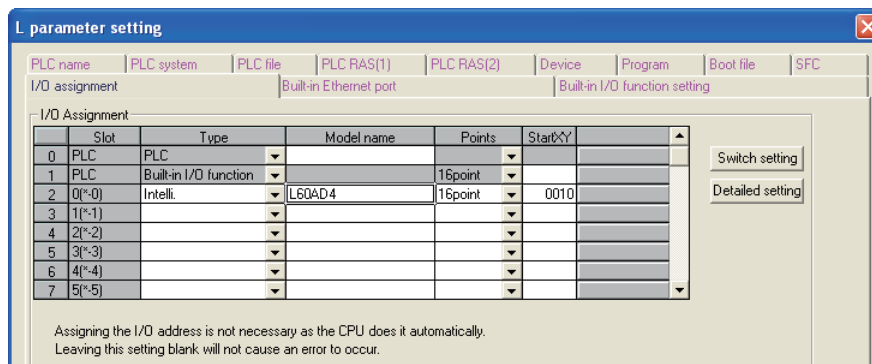

Item	Description
Type	Select "Intelli.".
Model name	Enter the model name of the A/D converter module.
Points	Select "16 point".
Start XY	Enter a desired start I/O number of the A/D converter module.

(2) Intelligent function module switch setting

Configure the setting from "Switch setting" in "PLC parameter".

Parameter ⇨ [PLC parameter] ⇨ [I/O assignment] ⇨ Click the **Switch setting** button.

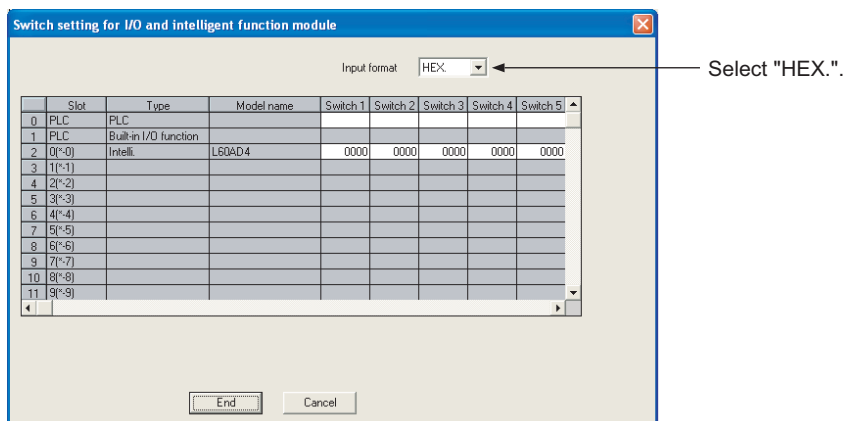

Item	Setting item	
	Analog input range	Input range setting
Switch 1 Input range setting (CH1 to CH4) <div style="display: flex; justify-content: space-around; align-items: center;"> <div style="border: 1px solid black; width: 15px; height: 15px; margin-right: 5px;"></div> <div style="border: 1px solid black; width: 15px; height: 15px; margin-right: 5px;"></div> <div style="border: 1px solid black; width: 15px; height: 15px; margin-right: 5px;"></div> <div style="border: 1px solid black; width: 15px; height: 15px; margin-right: 5px;"></div> <div style="margin-left: 5px;">H</div> </div> <div style="display: flex; justify-content: space-around; margin-top: 5px;"> CH4CH3CH2CH1 </div>	4 to 20mA	0 _H
	0 to 20mA	1 _H
	1 to 5V	2 _H
	0 to 5V	3 _H
	-10 to 10V	4 _H
	0 to 10V	5 _H
	4 to 20mA (Extended mode)	A _H
	1 to 5V (Extended mode)	B _H
	User range setting	F _H
Switch 2	0: Fixed (blank)	
Switch 3	0: Fixed (blank)	
Switch 4	<div style="display: flex; justify-content: center; align-items: center;"> <div style="border: 1px solid black; width: 15px; height: 15px; margin-right: 5px;"></div> <div style="border: 1px solid black; width: 15px; height: 15px; margin-right: 5px;"></div> <div style="border: 1px solid black; width: 15px; height: 15px; margin-right: 5px;"></div> <div style="border: 1px solid black; width: 15px; height: 15px; margin-right: 5px;"></div> <div style="margin-left: 5px;">H</div> </div> <p style="margin-left: 100px;">↑ Fixed to 000_H</p> <p style="margin-left: 100px;">↑ 0_H</p> <p style="margin-left: 100px;">: Normal (A/D converter processing) mode</p> <p style="margin-left: 100px;">1_H to F_H (A value other than 0_H) *1 : Offset/gain setting mode</p>	
	0: Fixed (blank)	
Switch 5	0: Fixed (blank)	

*1 The operation is the same when any value within the setting range is set.



Appendix 9.2 Operation of GX Configurator-AD

When setting the A/D converter module parameter using GX Configurator-AD, the display method such as a setting screen differs from that of GX Works2.

This section describes the screen display method of GX Configurator-AD.

Setting of contents added to the A/D conversion module cannot be configured when the upper 5 digits of product information are 13041 or later. Set by programming. Other setting contents are the same as those of GX Works2.

( Page 48, CHAPTER 7)

When using GX Configurator-AD, configure the settings on the following screens.

Screen name	Application
Initial setting	This setting configures the settings such as A/D conversion enable/disable setting.
Auto refresh setting	This setting transfers data in the buffer memory to specified devices.
Monitor/test	This function enables the user to monitor/test the buffer memory and I/O signals, and configure the operating condition setting and offset/gain setting.
FB conversion	This function generates FB automatically from the intelligent function module parameter (initial setting/auto refresh).

GX Developer screen

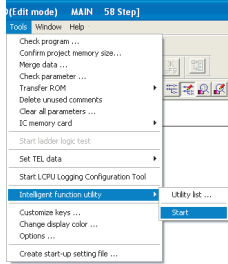

[Tools] - [Intelligent function utility] - [Start]

Screen for selecting a target intelligent function module

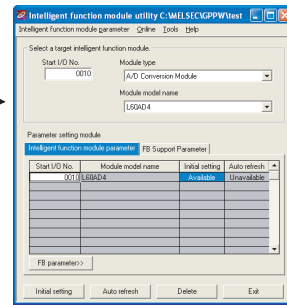

Initial setting

Initial setting screen

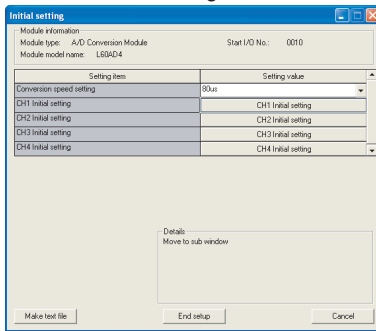

Auto refresh

Auto refresh setting screen

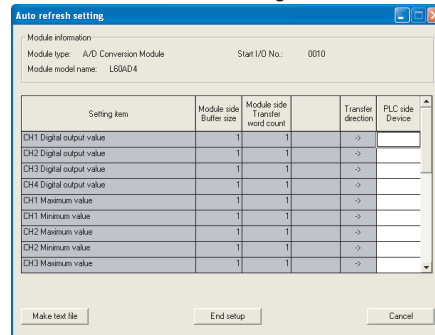

CH Initial setting

CH Initial setting screen

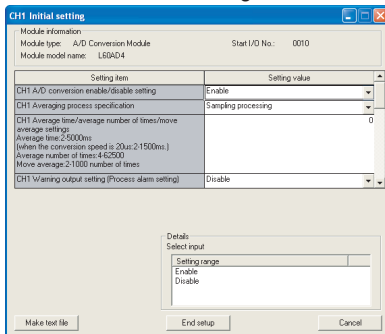

1) [Online] - [Monitor/Test] <<FB Support Parameter>> tab - FB conversion

Select monitor/test module screen

FB conversion screen

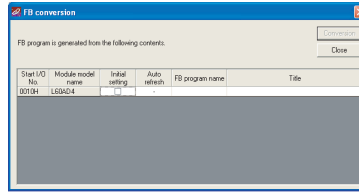
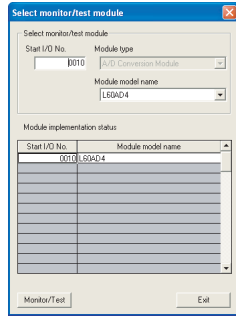

Select a module to be monitored/tested.

Monitor/Test screen

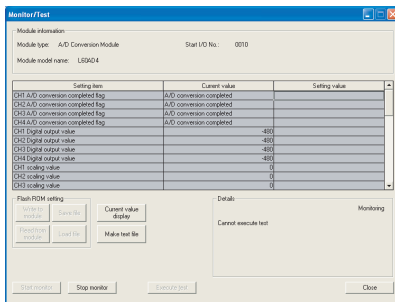

Appendix 10 External Dimensions

The following shows the external dimensions of A/D converter module.

(1) L60AD4

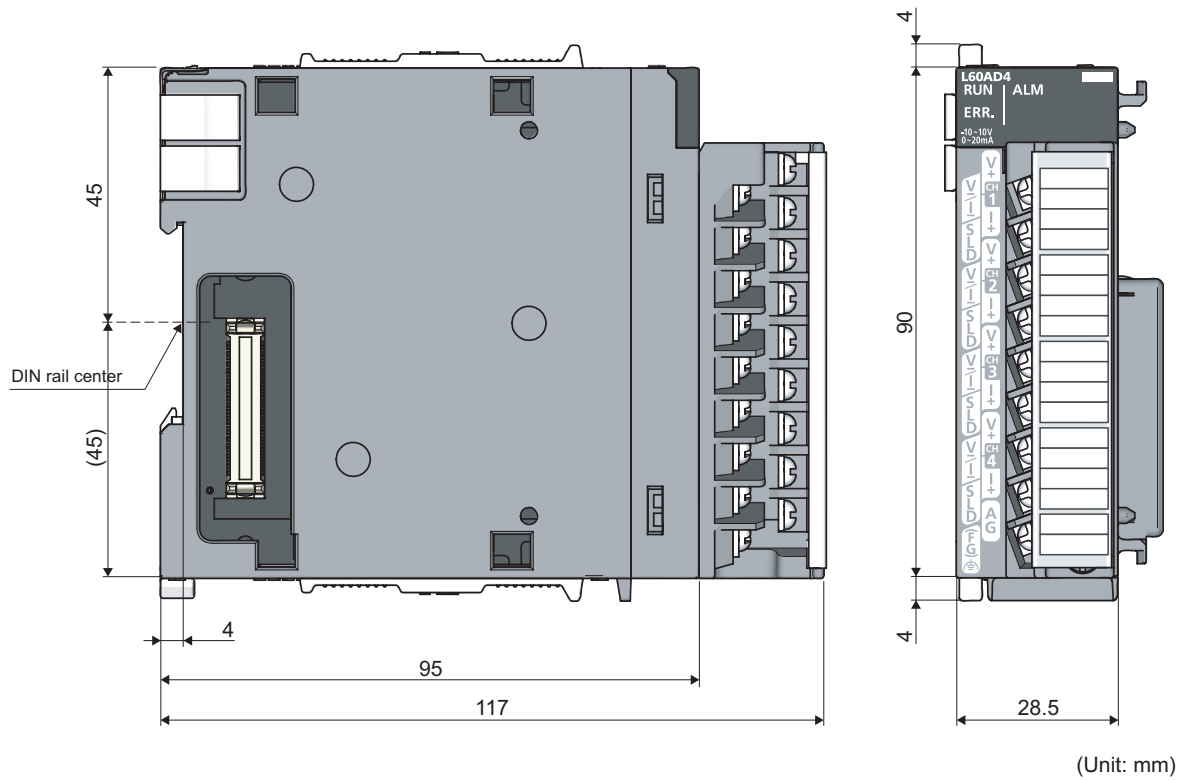

A

Memo

INDEX

A

A/D conversion accuracy	208
A/D conversion completed flag (Un\G10)	175
A/D conversion completed flag (XE)	171
A/D conversion enable/disable function	63
A/D conversion enable/disable setting (Un\G0)	174
A/D conversion method	63
Averaging processing	63
Sampling processing	63
Addition of modules	48
Auto refresh	53
Averaging process setting (Un\G24)	177
Averaging process setting (used to replace Q64AD) (Un\G9)	175

C

CH1 Industrial shipment settings offset value (L) (Un\G202) to CH4 User range settings gain value (H) (Un\G233)	187
Channel change completed flag (XB)	169
Channel change request (YB)	173
CH□ Difference conversion reference value (Un\G180 to Un\G183)	186
CH□ Difference conversion status flag (Un\G190 to Un\G193)	187
CH□ Difference conversion trigger (Un\G172 to Un\G175)	186
CH□ Digital output value (Un\G11 to Un\G14)	176
CH□ Flow amount integration enable/disable setting (Un\G1300 to Un\G1303)	198
CH□ Flow amount integration temporary stop flag (Un\G1364 to Un\G1367)	201
CH□ Flow amount integration temporary stop request (Un\G1356 to Un\G1359)	200
CH□ Flow amount time unit setting (Un\G1316 to Un\G1319)	199
CH□ Head pointer (Un\G1090 to Un\G1093)	195
CH□ Input signal error detection setting value (Un\G142 to Un\G145)	184
CH□ Integrated flow amount (Un\G1332 to Un\G1339)	200
CH□ Integrated flow amount clear flag (Un\G1380 to Un\G1383)	201
CH□ Integrated flow amount clear request (Un\G1372 to Un\G1375)	201
CH□ Integration cycle monitor value (Un\G1348 to Un\G1351)	200
CH□ Integration cycle setting (Un\G1308 to Un\G1311)	198
CH□ Latest pointer (Un\G1098 to Un\G1101)	195
CH□ Level trigger condition setting (Un\G1056 to Un\G1059)	192
CH□ Logging cycle monitor value (Un\G1122 to Un\G1133)	197
CH□ Logging cycle setting value (Un\G1032 to Un\G1035)	191
CH□ Logging cycle unit setting (Un\G1040 to Un\G1043)	191

CH□ Logging data (Un\G5000 to Un\G44999)	202
CH□ Logging data setting (Un\G1024 to Un\G1027)	190
CH□ Logging enable/disable setting (Un\G1000 to Un\G1003)	188
CH□ Logging hold flag (Un\G1016 to Un\G1019)	189
CH□ Logging hold request (Un\G1008 to Un\G1011)	189
CH□ Logging points after trigger (Un\G1048 to Un\G1051)	192
CH□ Maximum value (Un\G30, Un\G32, Un\G34, Un\G36)	179
CH□ Minimum value (Un\G31, Un\G33, Un\G35, Un\G37)	179
CH□ Number of logging data (Un\G1106 to Un\G1109)	196
CH□ Process alarm lower lower limit value (Un\G86, Un\G90, Un\G94, Un\G98)	183
CH□ Process alarm lower upper limit value (Un\G87, Un\G91, Un\G95, Un\G99)	183
CH□ Process alarm upper lower limit value (Un\G88, Un\G92, Un\G96, Un\G100)	183
CH□ Process alarm upper upper limit value (Un\G89, Un\G93, Un\G97, Un\G101)	183
CH□ Scaling lower limit value (Un\G62, Un\G64, Un\G66, Un\G68)	182
CH□ Scaling upper limit value (Un\G63, Un\G65, Un\G67, Un\G69)	182
CH□ Scaling value (digital operation value) (Un\G54 to Un\G57)	182
CH□ Shifting amount to conversion value (Un\G150 to Un\G153)	185
CH□ Time Average/ Count Average/Moving Average (Un\G1 to Un\G4)	174
CH□ Trigger data (Un\G1064 to Un\G1067)	193
CH□ Trigger detection time (Un\G1154 to Un\G1169)	197
CH□ Trigger pointer (Un\G1114 to Un\G1117)	196
CH□ Trigger setting value (Un\G1082 to Un\G1085)	194
CH□ Unit scaling setting (Un\G1324 to Un\G1327)	199
Conversion speed setting (Un\G26)	178
Conversion speed switch function	68
Count average	64
Current input characteristic	206

D

Difference conversion function	94
Digital clipping enable/disable setting (Un\G29)	179
Digital clipping function	90
Digital output value	61
Disconnection detection	74,75

E

Error clear function	123
Error clear request (YF)	173

Error history No.□ (Un\G1810 to Un\G1969)	202
Error log function	119
Error occurrence flag (XF)	171
External wiring	47

F

Flow amount integration function	110
--	-----

G

Gain value	203
----------------------	-----

H

Hardware LED information	166
Hardware switch information	166

I

I/O assignment	226
Input range extended mode function	67
Input signal error detection extension function	74
Input signal error detection extension setting (Un\G27)	178
Input signal error detection flag (Un\G49)	180
Input signal error detection function	69
Input signal error detection setting (Un\G47)	179
Input signal error detection signal (XC)	170
Intelligent function module switch setting	227

L

Latest error code (Un\G19)	176
Latest error code address (Un\G1800)	202
Level data □ (Un\G1072 to Un\G1081)	194
Logging function	98
Lower limit detection	74
Lower upper limit detection	74

M

Maximum and minimum values	62
Maximum and minimum values hold function	68
Maximum value/minimum value reset completed flag (XD)	171
Maximum value/minimum value reset request (YD)	173
Mode switching setting (Un\G158, Un\G159)	185
Module error collection function	122
Module READY (X0)	167
Moving average	65

O

Offset value	203
Offset/gain setting	54
Offset/gain setting mode flag (XA)	169
Offset/gain setting mode Gain specification (Un\G23)	177
Offset/gain setting mode Offset specification (Un\G22)	177
Operating condition setting completed flag (X9)	168

Operating condition setting request (Y9)	172
--	-----

P

Parameter setting	50
Pass data classification setting (Un\G200)	187

R

Range reference tables	128
----------------------------------	-----

S

Saving and restoring offset/gain values	124
Scaling enable/disable setting (Un\G53)	181
Scaling function	80
Scaling values (digital operation values)	62
Setting range (Un\G20)	176
Shift function	86
Switch setting	49

T

Time average	64
------------------------	----

U

Upper limit detection	74
User range write request (YA)	172

V

Voltage input characteristic	204
--	-----

W

Warning output flag (Process alarm) (Un\G50)	181
Warning output function (process alarm)	77
Warning output setting (Un\G48)	180
Warning output signal (X8)	167

INSTRUCTION INDEX

G

G(P).OFFGAN	210
G(P).OGLOAD	212
G(P).OGSTOR	216



REVISIONS

*The manual number is given on the bottom left of the back cover.

Print date	*Manual number	Revision
January 2010	SH(NA)-080899ENG-A	First edition
April 2010	SH(NA)-080899ENG-B	<p>Partial correction SAFETY PRECAUTIONS, COMPLIANCE WITH THE EMC AND LOW VOLTAGE DIRECTIVES, RELEVANT MANUALS, TERMS, CHAPTER 3, Section 3.1, 3.2.1, 3.3, 3.5, CHAPTER 4, Section 5.1, 5.2, Section 6.1, 6.4, Section 7.1, 7.2, 7.3, 7.4, 7.5, 7.5.1, Section 8.3, 8.4, 8.5, 8.6, 8.8, Section 9.3, 9.4, Section 10.2, CHAPTER 11, Section 11.4, 11.6, APPENDICES 2</p> <p>Additions Section 5.3, Section 7.5.1, Section 10.3</p> <p>Modification APPENDICES 8.1 → Section 7.5.2</p>
October 2011	SH(NA)-080899ENG-C	<p>Partial correction COMPLIANCE WITH EMC AND LOW VOLTAGE DIRECTIVES, MANUAL PAGE ORGANIZATION, Section 1.2, Section 3.2, 3.2.1, 3.3, 3.5, Section 7.1, 7.2, 7.3, 7.4, 7.5, Section 8.1, 8.3, 8.6, 8.7, 8.9, 8.10, 8.16, 8.18, 8.19, Section 9.2, 9.3, Section 10.1, 10.2, 10.3, Section 11.1, 11.4, 11.5, 11.6, Appendix 1, 1.1, 1.2, Appendix 2, Appendix 3, Appendix 9.1, 9.2</p> <p>Additions Section 8.4, 8.8, 8.11, 8.12, 8.13, 8.14, 8.15, Appendix 7</p>

Japanese manual version SH-080877-C

This manual confers no industrial property rights or any rights of any other kind, nor does it confer any patent licenses. Mitsubishi Electric Corporation cannot be held responsible for any problems involving industrial property rights which may occur as a result of using the contents noted in this manual.

© 2010 MITSUBISHI ELECTRIC CORPORATION

WARRANTY

Please confirm the following product warranty details before using this product.

1. Gratis Warranty Term and Gratis Warranty Range

If any faults or defects (hereinafter "Failure") found to be the responsibility of Mitsubishi occurs during use of the product within the gratis warranty term, the product shall be repaired at no cost via the sales representative or Mitsubishi Service Company.

However, if repairs are required onsite at domestic or overseas location, expenses to send an engineer will be solely at the customer's discretion. Mitsubishi shall not be held responsible for any re-commissioning, maintenance, or testing on-site that involves replacement of the failed module.

[Gratis Warranty Term]

The gratis warranty term of the product shall be for one year after the date of purchase or delivery to a designated place.

Note that after manufacture and shipment from Mitsubishi, the maximum distribution period shall be six (6) months, and the longest gratis warranty term after manufacturing shall be eighteen (18) months. The gratis warranty term of repair parts shall not exceed the gratis warranty term before repairs.

[Gratis Warranty Range]

- (1) The range shall be limited to normal use within the usage state, usage methods and usage environment, etc., which follow the conditions and precautions, etc., given in the instruction manual, user's manual and caution labels on the product.
- (2) Even within the gratis warranty term, repairs shall be charged for in the following cases.
 1. Failure occurring from inappropriate storage or handling, carelessness or negligence by the user. Failure caused by the user's hardware or software design.
 2. Failure caused by unapproved modifications, etc., to the product by the user.
 3. When the Mitsubishi product is assembled into a user's device, Failure that could have been avoided if functions or structures, judged as necessary in the legal safety measures the user's device is subject to or as necessary by industry standards, had been provided.
 4. Failure that could have been avoided if consumable parts (battery, backlight, fuse, etc.) designated in the instruction manual had been correctly serviced or replaced.
 5. Failure caused by external irresistible forces such as fires or abnormal voltages, and Failure caused by force majeure such as earthquakes, lightning, wind and water damage.
 6. Failure caused by reasons unpredictable by scientific technology standards at time of shipment from Mitsubishi.
 7. Any other failure found not to be the responsibility of Mitsubishi or that admitted not to be so by the user.

2. Onerous repair term after discontinuation of production

- (1) Mitsubishi shall accept onerous product repairs for seven (7) years after production of the product is discontinued.
Discontinuation of production shall be notified with Mitsubishi Technical Bulletins, etc.
- (2) Product supply (including repair parts) is not available after production is discontinued.

3. Overseas service

Overseas, repairs shall be accepted by Mitsubishi's local overseas FA Center. Note that the repair conditions at each FA Center may differ.

4. Exclusion of loss in opportunity and secondary loss from warranty liability

Regardless of the gratis warranty term, Mitsubishi shall not be liable for compensation of damages caused by any cause found not to be the responsibility of Mitsubishi, loss in opportunity, lost profits incurred to the user by Failures of Mitsubishi products, special damages and secondary damages whether foreseeable or not, compensation for accidents, and compensation for damages to products other than Mitsubishi products, replacement by the user, maintenance of on-site equipment, start-up test run and other tasks.

5. Changes in product specifications

The specifications given in the catalogs, manuals or technical documents are subject to change without prior notice.

Microsoft, Windows, Windows NT, and Windows Vista are registered trademarks of Microsoft Corporation in the United States and other countries.

Pentium is a trademark of Intel Corporation in the United States and other countries.

Ethernet is a trademark of Xerox Corporation.

All other company names and product names used in this manual are trademarks or registered trademarks of their respective companies.

SPREAD

Copyright(C) 1996 FarPoint Technologies, Inc.

MELSEC-L Analog-Digital Converter Module User's Manual

MODEL	L-A/D-U-E
MODEL CODE	13JZ42
SH(NA)-080899ENG-C(1110)MEE	



HEAD OFFICE : TOKYO BUILDING, 2-7-3 MARUNOUCHI, CHIYODA-KU, TOKYO 100-8310, JAPAN
NAGOYA WORKS : 1-14, YADA-MINAMI 5-CHOME, HIGASHI-KU, NAGOYA, JAPAN

When exported from Japan, this manual does not require application to the
Ministry of Economy, Trade and Industry for service transaction permission.

Specifications subject to change without notice.

HEADQUARTERS

MITSUBISHI ELECTRIC EUROPE B.V. **EUROPE**
 German Branch
 Gothaer Straße 8
D-40880 Ratingen
 Phone: +49 (0)2102 / 486-0
 Fax: +49 (0)2102 / 486-1120

MITSUBISHI ELECTRIC EUROPE B.V.-org.sl. **CZECH REP.**
 Czech Branch
 Avenir Business Park, Radlická 714/113a
CZ-158 00 Praha 5
 Phone: +420 - 251 551 470
 Fax: +420 - 251-551-471

MITSUBISHI ELECTRIC EUROPE B.V. **FRANCE**
 French Branch
 25, Boulevard des Bouvets
F-92741 Nanterre Cedex
 Phone: +33 (0)1 / 55 68 55 68
 Fax: +33 (0)1 / 55 68 57 57

MITSUBISHI ELECTRIC EUROPE B.V. **IRELAND**
 Irish Branch
 Westgate Business Park, Ballymount
IRL-Dublin 24
 Phone: +353 (0)1 4198800
 Fax: +353 (0)1 4198890

MITSUBISHI ELECTRIC EUROPE B.V. **ITALY**
 Italian Branch
 Viale Colleoni 7
I-20041 Agrate Brianza (MB)
 Phone: +39 039 / 60 53 1
 Fax: +39 039 / 60 53 312

MITSUBISHI ELECTRIC EUROPE B.V. **POLAND**
 Poland Branch
 Krakowska 50
PL-32-083 Balice
 Phone: +48 (0)12 / 630 47 00
 Fax: +48 (0)12 / 630 47 01

MITSUBISHI ELECTRIC EUROPE B.V. **RUSSIA**
 52, bid. 3 Kosmodamienskaya nab 8 floor
RU-115054 Moscow
 Phone: +7 495 721-2070
 Fax: +7 495 721-2071

MITSUBISHI ELECTRIC EUROPE B.V. **SPAIN**
 Spanish Branch
 Carretera de Rubí 76-80
E-08190 Sant Cugat del Vallés (Barcelona)
 Phone: 902 131121 // +34 935653131
 Fax: +34 935891579

MITSUBISHI ELECTRIC EUROPE B.V. **UK**
 UK Branch
 Travellers Lane
UK-Hatfield, Herts. AL10 8XB
 Phone: +44 (0)1707 / 27 61 00
 Fax: +44 (0)1707 / 27 86 95

MITSUBISHI ELECTRIC CORPORATION **JAPAN**
 Office Tower "Z" 14 F
 8-12,1 chome, Harumi Chuo-Ku
Tokyo 104-6212
 Phone: +81 3 622 160 60
 Fax: +81 3 622 160 75

MITSUBISHI ELECTRIC AUTOMATION, Inc. **USA**
 500 Corporate Woods Parkway
Vernon Hills, IL 60061
 Phone: +1 847 478 21 00
 Fax: +1 847 478 22 53

EUROPEAN REPRESENTATIVES

GEVA **AUSTRIA**
 Wiener Straße 89
AT-2500 Baden
 Phone: +43 (0)2252 / 85 55 20
 Fax: +43 (0)2252 / 488 60

TECHNIKON **BELARUS**
 Oktyabrskaya 19, Off. 705
BY-220030 Minsk
 Phone: +375 (0)17 / 210 46 26
 Fax: +375 (0)17 / 210 46 26

ESCO DRIVES & AUTOMATION **BELGIUM**
 Culliganlaan 3
BE-1831 Diegem
 Phone: +32 (0)2 / 717 64 30
 Fax: +32 (0)2 / 717 64 31

Koning & Hartman b.v. **BELGIUM**
 Woluwelaan 31
BE-1800 Vilvoorde
 Phone: +32 (0)2 / 257 02 40
 Fax: +32 (0)2 / 257 02 49

INEA RBT d.o.o. **BOSNIA AND HERZEGOVINA**
 Aleja Lipa 56
BA-71000 Sarajevo
 Phone: +387 (0)33 / 921 164
 Fax: +387 (0)33 / 524 539

AKHNATON **BULGARIA**
 4, Andrej Ljapchev Blvd., PO Box 21
BG-1756 Sofia
 Phone: +359 (0)2 / 817 6000
 Fax: +359 (0)2 / 97 44 06 1

INEA RBT d.o.o. **CROATIA**
 Losinjska 4 a
HR-10000 Zagreb
 Phone: +385 (0)1 / 36 940 -01 / -02 / -03
 Fax: +385 (0)1 / 36 940 -03

AutoCont C.S. s.r.o. **CZECH REPUBLIC**
 Technologická 374/6
CZ-708 00 Ostrava-Pustkovec
 Phone: +420 595 691 150
 Fax: +420 595 691 199

Beijer Electronics A/S **DENMARK**
 Lykkegårdsvej 17
DK-4000 Roskilde
 Phone: +45 (0)46 / 75 76 66
 Fax: +45 (0)46 / 75 56 26

Beijer Electronics Eesti OÜ **ESTONIA**
 Pärnu mnt.160i
EE-11317 Tallinn
 Phone: +372 (0)6 / 51 81 40
 Fax: +372 (0)6 / 51 81 49

Beijer Electronics OY **FINLAND**
 Peltoie 37
FIN-28400 Ulvila
 Phone: +358 (0)207 / 463 540
 Fax: +358 (0)207 / 463 541

UTEKO **GREECE**
 5, Mavrogenous Str.
GR-18542 Piraeus
 Phone: +30 211 / 1206 900
 Fax: +30 211 / 1206 999

MELTRADE Kft. **HUNGARY**
 Fertő utca 14.
HU-1107 Budapest
 Phone: +36 (0)1 / 431-9726
 Fax: +36 (0)1 / 431-9727

Beijer Electronics SIA **LATVIA**
 Rītausmas iela 23
LV-1058 Rīga
 Phone: +371 (0)784 / 2280
 Fax: +371 (0)784 / 2281

Beijer Electronics UAB **LITHUANIA**
 Savanoriu Pr. 187
LT-02300 Vilnius
 Phone: +370 (0)5 / 232 3101
 Fax: +370 (0)5 / 232 2980

EUROPEAN REPRESENTATIVES

ALFATRADE Ltd. **MALTA**
 99, Paola Hill
Malta- Paola PLA 1702
 Phone: +356 (0)21 / 697 816
 Fax: +356 (0)21 / 697 817

INTEHSIS srl **MOLDOVA**
 bld. Traian 23/1
MD-2060 Kishinev
 Phone: +373 (0)22 / 66 4242
 Fax: +373 (0)22 / 66 4280

HIFLEX AUTOM.TECHNIEK B.V. **NETHERLANDS**
 Wolweverstraat 22
NL-2984 CD Ridderkerk
 Phone: +31 (0)180 - 46 60 04
 Fax: +31 (0)180 - 44 23 55

Koning & Hartman b.v. **NETHERLANDS**
 Haarlerbergweg 21-23
NL-1101 CH Amsterdam
 Phone: +31 (0)20 / 587 76 00
 Fax: +31 (0)20 / 587 76 05

Beijer Electronics AS **NORWAY**
 Postboks 487
NO-3002 Drammen
 Phone: +47 (0)32 / 24 30 00
 Fax: +47 (0)32 / 84 85 77

Fonseca S.A. **PORTUGAL**
 R. João Francisco do Casal 87/89
PT - 3801-997 Aveiro, Esgueira
 Phone: +351 (0)234 / 303 900
 Fax: +351 (0)234 / 303 910

Sirius Trading & Services srl **ROMANIA**
 Aleea Lacul Morii Nr. 3
RO-060841 Bucuresti, Sector 6
 Phone: +40 (0)21 / 430 40 06
 Fax: +40 (0)21 / 430 40 02

INEA RBT d.o.o. **SERBIA**
 Izletnicka 10
SER-113000 Smederevo
 Phone: +381 (0)26 / 615 401
 Fax: +381 (0)26 / 615 401

SIMAP s.r.o. **SLOVAKIA**
 Jána Derku 1671
SK-911 01 Trenčín
 Phone: +421 (0)32 743 04 72
 Fax: +421 (0)32 743 75 20

PROCONT, spol. s r.o. **SLOVAKIA**
 Prešov
 Kúpeľná 1/A
SK-080 01 Prešov
 Phone: +421 (0)51 7580 611
 Fax: +421 (0)51 7580 650

INEA RBT d.o.o. **SLOVENIA**
 Stegne 11
SI-1000 Ljubljana
 Phone: +386 (0)1 / 513 8116
 Fax: +386 (0)1 / 513 8170

Beijer Electronics AB **SWEDEN**
 Box 426
SE-20124 Malmö
 Phone: +46 (0)40 / 35 86 00
 Fax: +46 (0)40 / 93 23 01

Omni Ray AG **SWITZERLAND**
 Im Schörl 5
CH-8600 Dübendorf
 Phone: +41 (0)44 / 802 28 80
 Fax: +41 (0)44 / 802 28 28

GTS **TURKEY**
 Bayraktar Bulvarı Nutuk Sok. No:5
TR-34775 Yukarı Dudullu-Ümraniye-İSTANBUL
 Phone: +90 (0)216 526 39 90
 Fax: +90 (0)216 526 3995

CSC Automation Ltd. **UKRAINE**
 4-B, M. Raskovoyi St.
UA-02660 Kiev
 Phone: +380 (0)44 / 494 33 55
 Fax: +380 (0)44 / 494-33-66

Systemgroup **UKRAINE**
 2 M. Krivonosy St.
UA-03680 Kiev
 Phone: +380 (0)44 / 490 92 29
 Fax: +380 (0)44 / 248 88 68

EURASIAN REPRESENTATIVES

TOO Kazpromavtomatika **KAZAKHSTAN**
 Ul. Zhambyla 28
KAZ-100017 Karaganda
 Phone: +7 7212 / 50 10 00
 Fax: +7 7212 / 50 11 50

MIDDLE EAST REPRESENTATIVES

ILAN & GAVISH Ltd. **ISRAEL**
 24 Shenkar St., Kiryat Arie
IL-49001 Petah-Tiqva
 Phone: +972 (0)3 / 922 18 24
 Fax: +972 (0)3 / 924 0761

GIRIT CELADON LTD **ISRAEL**
 12 H'aomanut Street
IL-42505 Netanya
 Phone: +972 (0)9 / 863 39 80
 Fax: +972 (0)9 / 885 24 30

CEG INTERNATIONAL **LEBANON**
 Cebaco Center/Block A Autostrade DORA
Lebanon - Beirut
 Phone: +961 (0)1 / 240 430
 Fax: +961 (0)1 / 240 438

AFRICAN REPRESENTATIVE

CBI Ltd. **SOUTH AFRICA**
 Private Bag 2016
ZA-1600 Isando
 Phone: + 27 (0)11 / 977 0770
 Fax: + 27 (0)11 / 977 0761