

# MITSUBISHI

Mitsubishi Programmable Controller

MELSEC *L*series

---

## MELSEC-L CC-Link IE Field Network Head Module User's Manual

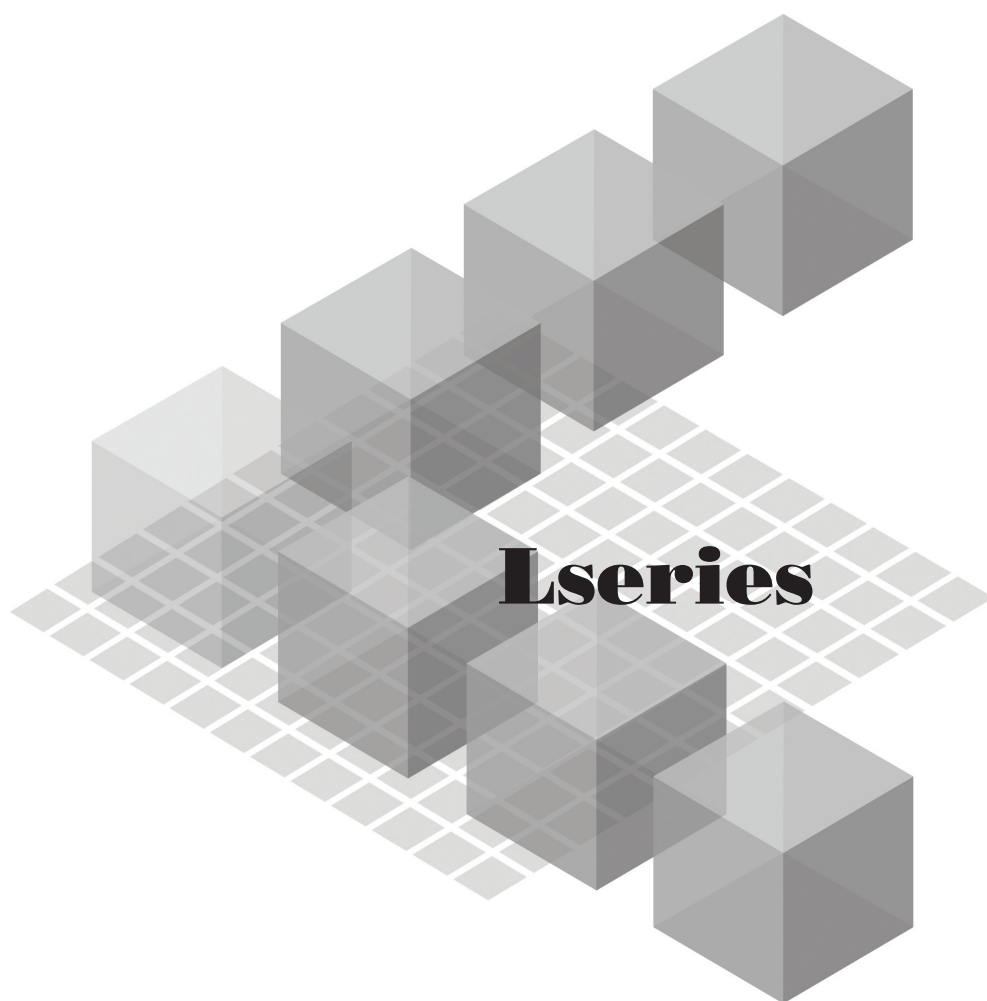

-LJ72GF15-T2

MODEL



# ● SAFETY PRECAUTIONS ●

(Read these precautions before using this product.)

Before using this product, please read this manual and the relevant manuals carefully and pay full attention to safety to handle the product correctly.

In this manual, the safety precautions are classified into two levels: " ⚠ WARNING" and " ⚠ CAUTION".



Indicates that incorrect handling may cause hazardous conditions, resulting in death or severe injury.

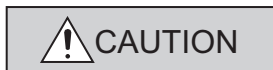

Indicates that incorrect handling may cause hazardous conditions, resulting in minor or moderate injury or property damage.

Under some circumstances, failure to observe the precautions given under " ⚠ CAUTION" may lead to serious consequences.

Observe the precautions of both levels because they are important for personal and system safety. Make sure that the end users read this manual and then keep the manual in a safe place for future reference.

## [Design Precautions]

### ⚠ WARNING

- Configure safety circuits external to the programmable controller to ensure that the entire system operates safely even when a fault occurs in the external power supply or the programmable controller. Failure to do so may result in an accident due to an incorrect output or malfunction.
  - (1) Emergency stop circuits, protection circuits, and protective interlock circuits for conflicting operations (such as forward/reverse rotations or upper/lower limit positioning) must be configured external to the programmable controller.
  - (2) When the programmable controller detects an abnormal condition, it stops the operation and all outputs are:
    - Turned off if the overcurrent or overvoltage protection of the power supply module is activated.
    - Held or turned off according to the parameter setting if the self-diagnostic function of the head module detects an error such as a watchdog timer error.All outputs may turn on when an error occurs in the part, such as I/O control part, where the head module cannot detect any error. To ensure safety operation in such a case, provide a safety mechanism or a fail-safe circuit external to the programmable controller.  
For the fail-safe circuit, refer to Page 149, Appendix 10.
- Outputs may remain on or off due to a failure of a component such as a relay and transistor in an output circuit. Configure an external circuit for monitoring output signals that could cause a serious accident.

## [Design Precautions]

### **WARNING**

- In an output circuit, when a load current exceeding the rated current or an overcurrent caused by a load short-circuit flows for a long time, it may cause smoke and fire. To prevent this, configure an external safety circuit, such as a fuse.
- Configure a circuit so that the programmable controller is turned on first and then the external power supply. If the external power supply is turned on first, an accident may occur due to an incorrect output or malfunction.
- Configure a circuit so that the programmable controller is turned off first and then the external power supply. If the external power supply is turned off first, an accident may occur due to an incorrect output or malfunction.
- For the operating status of each station after a communication failure, refer to relevant manuals for each network. Incorrect output or malfunction due to a communication failure may result in an accident.
- When changing data from a peripheral device connected to the head module during operation, configure an interlock circuit in the program of the master station to ensure that the entire system will always operate safely.  
For other controls to a running programmable controller (such as modification of the master station program or operating status change), read relevant manuals carefully and ensure the safety before the operation. Especially, in the case of a control from an external device to a remote programmable controller, immediate action cannot be taken for a problem on the programmable controller due to a communication failure. To prevent this, configure an interlock circuit in the program of the master station, and determine corrective actions to be taken between the external device and head module in case of a communication failure.
- When a module is faulty, an analog output may remain on. Configure an external interlock circuit for output signals that could cause a serious accident.
- Do not write any data to the "system area" and "write-protect area" (R) of the buffer memory in the intelligent function module. Also, do not use any "use prohibited" signals as an output signal from the head module to the intelligent function module. Doing so may cause malfunction of the programmable controller system.
- Disconnection of any communication cable (such as a CC-Link dedicated cable) may cause an unstable line condition, resulting in a communication failure at multiple stations on the network. Configure an interlock circuit in the program to ensure that the entire system will always operate safety even in case of a communication failure. Failure to do so may result in an accident due to an incorrect output or malfunction.

## [Design Precautions]

### CAUTION

- Do not install the control lines or communication cables together with the main circuit lines or power cables. Keep a distance of 100mm or more between them. Failure to do so may result in malfunction due to noise.
- During control of an inductive load such as a lamp, heater, or solenoid valve, a large current (approximately ten times greater than normal) may flow when the output is turned from off to on. Therefore, use a module that has a sufficient current rating.
- When the system is powered on, a surge voltage may occur or inrush current may flow between output terminals of an analog output module. Start the control after analog outputs are stabilized.

## [Installation Precautions]

### WARNING

- Shut off the external power supply for the system in all phases before mounting or removing a module. Failure to do so may result in electric shock or cause the module to fail or malfunction.

## [Installation Precautions]

### CAUTION

- Use the head module in an environment that meets the general specifications in this manual. Failure to do so may result in electric shock, fire, malfunction, or damage to or deterioration of the product.
- To interconnect modules, engage the respective connectors and securely lock the module joint levers. Incorrect interconnection may cause malfunction, failure, or drop of the module.
- Tighten the screw within the specified torque range. Undertightening can cause drop of the screw, short circuit or malfunction. Overtightening can damage the screw and/or module, resulting in drop, short circuit, or malfunction.
- Do not directly touch any conductive parts and electronic components of the module. Doing so can cause malfunction or failure of the module.

## [Wiring Precautions]

### WARNING

- Shut off the external power supply for the system in all phases before wiring. Failure to do so may result in electric shock or cause the module to fail or malfunction.
- After installation and wiring, attach the included terminal cover to the module before turning it on for operation. Failure to do so may result in electric shock.

## [Wiring Precautions]

### CAUTION

- Ground the FG and LG terminals to the protective ground conductor dedicated to the programmable controller. Failure to do so may result in electric shock or malfunction.
- Use applicable solderless terminals and tighten them within the specified torque range. If any spade solderless terminal is used, it may be disconnected when a terminal block screw comes loose, resulting in failure.
- Check the rated voltage and terminal layout before wiring to the module, and connect the cables correctly. Connecting a power supply with a different voltage rating or incorrect wiring may cause a fire or failure.
- Connectors for external devices must be crimped or pressed with the tool specified by the manufacturer, or must be correctly soldered. Incomplete connections may cause short circuit, fire, or malfunction.
- Securely connect the connector to the module.
- Do not install the control lines or communication cables together with the main circuit lines or power cables. Failure to do so may result in malfunction due to noise.
- Place the cables in a duct or clamp them. If not, dangling cable may swing or inadvertently be pulled, resulting in damage to the module or cables or malfunction due to poor contact.

## [Wiring Precautions]

### CAUTION

- Check the interface type and properly connect the cable. Incorrect wiring (connecting the cable to an incorrect interface) may cause failure of the module and external device.
- Tighten the terminal block screw within the specified torque range. Undertightening can cause short circuit, fire, or malfunction. Overtightening can damage the screw and/or module, resulting in drop, short circuit, or malfunction.
- When disconnecting the cable from the module, do not pull the cable by the cable part. For the cable with connector, hold the connector part of the cable. Pulling the cable connected to the module may result in malfunction or damage to the module or cable.
- Prevent foreign matter such as dust or wire chips from entering the module. Such foreign matter can cause a fire, failure, or malfunction.
- A protective film is attached to the top of the module to prevent foreign matter, such as wire chips, from entering the module during wiring. Do not remove the film during wiring. Remove it for heat dissipation before system operation.
- When connecting a CC-Link system master/local module to the head module, use CC-Link dedicated cables for the CC-Link system. If any other cable is used, the performance of the CC-Link system is not guaranteed. Observe the cable specifications (maximum cable length and station-to-station cable length) described in the MELSEC-L CC-Link System Master/Local Module User's Manual. If not, proper data transmission is not guaranteed.
- When the high-speed counter module is connected to the head module, ground the shield cable on the encoder side (relay box). Always ground the FG and LG terminals to the protective ground conductor. Failure to do so may cause malfunction.
- Mitsubishi programmable controllers must be installed in control panels. Connect the main power supply to the power supply module in the control panel through a relay terminal block. Wiring and replacement of a power supply module must be performed by qualified maintenance personnel with knowledge of protection against electric shock. For wiring methods, refer to the MELSEC-L CPU Module User's Manual (Hardware Design, Maintenance and Inspection).

## [Startup and Maintenance Precautions]

### **WARNING**

- Do not touch any terminal while power is on. Doing so will cause electric shock or malfunction.
- Shut off the external power supply for the system in all phases before cleaning the module or retightening the terminal block screw. Failure to do so may result in electric shock.

## [Startup and Maintenance Precautions]

### **CAUTION**

- Before performing online operations (especially, master station program modification, forced output, and operating status change) for the running head module from the peripheral device connected, read relevant manuals carefully and ensure the safety. Improper operation may damage machines or cause accidents.
- Do not disassemble or modify the modules. Doing so may cause failure, malfunction, injury, or a fire.
- Use any radio communication device such as a cellular phone or PHS (Personal Handy-phone System) more than 25cm away in all directions from the programmable controller. Failure to do so may cause malfunction.
- Shut off the external power supply for the system in all phases before mounting or removing a module. Failure to do so may cause the module to fail or malfunction.
- Tighten the terminal block screw within the specified torque range. Undertightening can cause drop of the component or wire, short circuit, or malfunction. Overtightening can damage the screw and/or module, resulting in drop, short circuit, or malfunction.
- After the first use of the product (module and terminal block), the number of connections/disconnections is limited to 50 times (in accordance with IEC 61131-2). Exceeding the limit may cause malfunction.
- Before handling the module, touch a conducting object such as a grounded metal to discharge the static electricity from the human body. Failure to do so may cause the module to fail or malfunction.

## [Operating Precautions]

### **CAUTION**

- When changing data and operating status, or modifying program of a running programmable controller from an external device such as a personal computer connected to an intelligent function module, read relevant manuals carefully and ensure the safety before operation. Incorrect change or modification may cause system malfunction, damage to the machines, or accidents.
- Do not power off the programmable controller or reset the head module while setting values of a module connected to the head module are written from the buffer memory to the flash ROM. Doing so will make the data in the flash ROM unreliable, and the data need to be set in the buffer memory and written to the flash ROM again. Also, it may cause the module to fail or malfunction.



## [Disposal Precautions]

 **CAUTION**

- When disposing of this product, treat it as industrial waste.

# ● CONDITIONS OF USE FOR THE PRODUCT ●

- (1) Mitsubishi programmable controller ("the PRODUCT") shall be used in conditions;
  - i) where any problem, fault or failure occurring in the PRODUCT, if any, shall not lead to any major or serious accident; and
  - ii) where the backup and fail-safe function are systematically or automatically provided outside of the PRODUCT for the case of any problem, fault or failure occurring in the PRODUCT.
  
- (2) The PRODUCT has been designed and manufactured for the purpose of being used in general industries.

MITSUBISHI SHALL HAVE NO RESPONSIBILITY OR LIABILITY (INCLUDING, BUT NOT LIMITED TO ANY AND ALL RESPONSIBILITY OR LIABILITY BASED ON CONTRACT, WARRANTY, TORT, PRODUCT LIABILITY) FOR ANY INJURY OR DEATH TO PERSONS OR LOSS OR DAMAGE TO PROPERTY CAUSED BY the PRODUCT THAT ARE OPERATED OR USED IN APPLICATION NOT INTENDED OR EXCLUDED BY INSTRUCTIONS, PRECAUTIONS, OR WARNING CONTAINED IN MITSUBISHI'S USER, INSTRUCTION AND/OR SAFETY MANUALS, TECHNICAL BULLETINS AND GUIDELINES FOR the PRODUCT.

("Prohibited Application")

Prohibited Applications include, but not limited to, the use of the PRODUCT in;

- Nuclear Power Plants and any other power plants operated by Power companies, and/or any other cases in which the public could be affected if any problem or fault occurs in the PRODUCT.
- Railway companies or Public service purposes, and/or any other cases in which establishment of a special quality assurance system is required by the Purchaser or End User.
- Aircraft or Aerospace, Medical applications, Train equipment, transport equipment such as Elevator and Escalator, Incineration and Fuel devices, Vehicles, Manned transportation, Equipment for Recreation and Amusement, and Safety devices, handling of Nuclear or Hazardous Materials or Chemicals, Mining and Drilling, and/or other applications where there is a significant risk of injury to the public or property.

Notwithstanding the above, restrictions Mitsubishi may in its sole discretion, authorize use of the PRODUCT in one or more of the Prohibited Applications, provided that the usage of the PRODUCT is limited only for the specific applications agreed to by Mitsubishi and provided further that no special quality assurance or fail-safe, redundant or other safety features which exceed the general specifications of the PRODUCTS are required. For details, please contact the Mitsubishi representative in your region.

# INTRODUCTION

---

Thank you for purchasing the Mitsubishi MELSEC-L series programmable controllers.

This manual describes the operating procedure, system configuration, parameter setting, functions, and troubleshooting of the CC-Link IE Field Network head module (hereafter abbreviated as head module).

Before using this product, please read this manual and the relevant manuals carefully and develop familiarity with the functions and performance of the MELSEC-L series programmable controller to handle the product correctly.

# RELEVANT MANUALS

## (1) CC-Link IE Field Network (relevant) manuals

When using the CC-Link IE Field Network for the first time, refer to the CC-Link IE Field Network Master/Local Module User's Manual.

Manual name <manual number (model code)>	Description
MELSEC-Q CC-Link IE Field Network Master/Local Module User's Manual  <SH-080917ENG, 13JZ47>	Overview of the CC-Link IE Field Network, and specifications, procedures before operation, system configuration, installation, wiring, settings, functions, programming, and troubleshooting of the CC-Link IE Field Network master/local module
MELSEC-L CC-Link IE Field Network Master/Local Module User's Manual  <SH-080972ENG, 13JZ54>	Overview of the CC-Link IE Field Network, and specifications, procedures before operation, system configuration, installation, wiring, settings, functions, programming, and troubleshooting of the CC-Link IE Field Network master/local module
CC-Link IE Field Network Interface Board User's Manual (For SW1DNC-CCIEF-B)  <SH-080980ENG, 13JZ58>	Specifications, procedures before operation, system configuration, settings, functions, programming, and troubleshooting of the CC-Link IE Field Network interface board

## (2) Operating manual

Manual name <manual number (model code)>	Description
GX Works2 Version1 Operating Manual (Common) <SH-080779ENG, 13JU63>	System configuration, parameter settings, and online operations (common to Simple project and Structured project) of GX Works2

# Memo

---

# CONTENTS

SAFETY PRECAUTIONS .....	1
CONDITIONS OF USE FOR THE PRODUCT .....	8
INTRODUCTION .....	9
RELEVANT MANUALS .....	10
MANUAL PAGE ORGANIZATION .....	15
TERM. ....	16
PACKING LIST .....	18
<hr/>	
<b>CHAPTER 1 HEAD MODULE</b> .....	<b>19</b>
<hr/>	
<b>CHAPTER 2 PART NAMES</b> .....	<b>22</b>
<hr/>	
<b>CHAPTER 3 SPECIFICATIONS</b> .....	<b>26</b>
<hr/>	
3.1 General Specifications .....	26
3.2 Performance Specifications .....	27
3.3 Function List .....	29
<hr/>	
<b>CHAPTER 4 PROCEDURES BEFORE OPERATION</b> .....	<b>30</b>
<hr/>	
4.1 Initial Start-up Procedure .....	30
4.2 Procedure for Changing the Head Module .....	32
<hr/>	
<b>CHAPTER 5 SYSTEM CONFIGURATION</b> .....	<b>35</b>
<hr/>	
5.1 Head Module System Configuration .....	35
5.2 Applicable Systems .....	36
<hr/>	
<b>CHAPTER 6 INSTALLATION AND WIRING</b> .....	<b>37</b>
<hr/>	
6.1 Wiring Environment and Installation Position .....	37
6.1.1 Installation environment .....	37
6.1.2 Installation position .....	37
6.2 Installation .....	38
6.2.1 Connecting modules .....	39
6.2.2 Mounting the modules on a DIN rail .....	40
6.2.3 Changing modules on a DIN rail .....	43
6.3 Wiring to the Power Supply Modules .....	45
6.4 Testing the Head Module Before Wiring .....	45
6.5 Wiring to the Head Module .....	47
6.5.1 Wiring .....	47
6.5.2 Grounding .....	49
6.5.3 Precautions .....	50
<hr/>	
<b>CHAPTER 7 PARAMETER SETTING</b> .....	<b>51</b>
<hr/>	
7.1 PLC Parameters .....	52
7.2 Network Parameters .....	62
7.3 Remote Password .....	63

7.4	Intelligent Function Module Parameters .....	64
<hr/> <b>CHAPTER 8 CYCLIC TRANSMISSION</b>		<b>65</b>
8.1	Cyclic Transmission of Bit Device Data .....	65
8.2	Cyclic Transmission of Word Device Data .....	71
<hr/> <b>CHAPTER 9 CC-Link IE FIELD NETWORK DIAGNOSTICS</b>		<b>75</b>
9.1	Diagnostic Items .....	75
9.2	Starting Diagnostics .....	76
9.3	Diagnostic Screen .....	78
9.4	Communication Test .....	80
9.5	Cable Test .....	80
9.6	System Monitor .....	81
9.7	Remote Operation .....	81
<hr/> <b>CHAPTER 10 MAINTENANCE AND INSPECTION</b>		<b>82</b>
10.1	Daily Inspection .....	82
10.2	Periodic Inspection .....	83
<hr/> <b>CHAPTER 11 TROUBLESHOOTING</b>		<b>84</b>
11.1	Before Troubleshooting .....	84
11.2	Troubleshooting Procedure .....	84
11.3	System Error History .....	89
11.4	Checking the LEDs .....	91
11.5	Troubleshooting by Symptom .....	94
11.5.1	Cyclic transmission cannot be performed .....	94
11.5.2	Transient transmission cannot be performed .....	94
11.6	Error Code List .....	95
<hr/> <b>APPENDICES</b>		<b>110</b>
Appendix 1	External Input/Output Forced On/Off .....	110
Appendix 2	File Password 32 .....	113
Appendix 2.1	Setting file passwords .....	114
Appendix 2.2	Password authentication .....	118
Appendix 3	END Cover .....	120
Appendix 4	Link Special Relay (SB) List .....	121
Appendix 5	Link Special Register (SW) List .....	122
Appendix 6	Special Relay (SM) List .....	125
Appendix 7	Special Register (SD) List .....	128
Appendix 8	Access and Attribute Codes .....	136
Appendix 9	EMC and Low Voltage Directives .....	137
Appendix 9.1	Requirements for Compliance with the EMC Directive .....	137
Appendix 9.2	Requirements to Compliance with the Low Voltage Directive .....	147

Appendix 10 General Safety Requirements .....	149
Appendix 11 Calculating Heating Value of Programmable Controller .....	150
Appendix 11.1 Calculating the average power consumption .....	150
Appendix 12 Processing Time .....	152
Appendix 13 New Function and Improved Function .....	153
Appendix 14 Checking Serial Number and Function Version .....	153
Appendix 15 External Dimensions .....	156

---

<b>INDEX</b> .....	<b>158</b>
REVISIONS .....	160
WARRANTY .....	161

---



# MANUAL PAGE ORGANIZATION

In this manual, pages are organized and the symbols are used as shown below.

The following page illustration is for explanation purpose only, and is different from the actual pages.

The diagram illustrates a manual page layout with various callouts explaining symbols and elements:

- ""** is used for screen names and items.
- 1.** shows operating procedures.
- ☞** shows mouse operations.\*1
- [ ]** is used for items in the menu bar and the project window.
- Ex.** shows setting or operating examples.
- 📖** shows reference manuals.
- ☞** shows reference pages.
- Point** shows notes that requires attention.
- Remark** shows useful information.

The manual page content includes:

**CHAPTER 7 VARIOUS SETTINGS**

**7.1.1 Setting method**

(1) Setting parameters

(a) Operating procedure

1. Open the "PLC Parameter" dialog box.  
Project window → [Parameter] → [PLC parameter]
2. Select the "IO Assignment" tab.

**Parameter Setting**

Item	Description	Reference
Type	Select the type of the connected module.	Page 74, Section 7.1.2
Model Name	Select the model name of the connected module.	Page 74, Section 7.1.3
Points	Set the number of points assigned to each slot.	Page 74, Section 7.1.4
Start XY	Specify a start I/O number for each slot.	Page 74, Section 7.1.5
Switch setting	Configure the switch setting of the built-in I/O or intelligent function modules.	Page 74, Section 7.1.6
Default setting	Set the following: - Error Time Output Mode - PLC Operation Mode at HW Error - I/O Response Time	Page 75, Section 7.1.7

Setting "Start XY" enables modification on the start I/O numbers assigned to connected modules.

**Ex.** When "1000" is specified in "Start XY" to the slot where a 16-point module is connected, the assignment range of an input module is changed to X1000 to X100F.

For details, refer to the following:  
MELSEC-L CPU Module User's Manual (Function Explanation, Program Fundamentals)

**Point**  
Set the type of the connected module in "Type". Setting a different type results in "SPUNIT LAY ERR."  
For the intelligent function module, the I/O points must also be the same in addition to the I/O assignment setting.  
Page 30, Section 4.2.2

**Remark**  
When an intelligent module is connected, I/O assignment can be omitted by selecting connected modules from "Intelligent Function Module" in the Project window.

\*1 The mouse operation example is provided below.



The screenshot shows the MELSOFT Series GX Works2 software interface with the following callouts:

- Menu bar:** **Ex.** ☞ [Online] → [Write to PLC...]  
Select [Online] on the menu bar, and then select [Write to PLC...].
- A window selected in the view selection area is displayed:** **Ex.** ☞ Project window → [Parameter] → [PLC Parameter]  
Select [Project] from the view selection area to open the Project window. In the Project window, expand [Parameter] and select [PLC Parameter].
- View selection area:** Shows the Project, User Library, and Connection Destination options.

# TERM

Unless otherwise specified, this manual uses the following terms.

Term	Description
GX Works2	The product name of the software package for the MELSEC programmable controllers
Programming tool	Another term for GX Works2
CC-Link IE Field Network	An open field network that offers a high-speed and large-capacity data communication using Ethernet (1000BASE-T).
CC-Link	A field network system where data processing for control and information can be simultaneously performed at high speed.
Master/local module	A generic term for the QJ71GF11-T2 and LJ71GF11-T2 CC-Link IE Field Network master/local modules
Head module	Abbreviation for the LJ72GF15-T2 CC-Link IE Field Network head module
Network module	Generic term for the following modules: <ul style="list-style-type: none"> <li>• CC-Link IE Field Network module</li> <li>• CC-Link IE Controller Network module</li> <li>• Ethernet interface module</li> <li>• MELSECNET/H module</li> <li>• MELSECNET/10 module</li> </ul>
Master station	Station that controls the entire network. Cyclic and transient transmission can be performed with all stations. One master station is required per network.
Local station	Cyclic and transient transmission can be performed with the master station and other local stations. The local station controls modules such as a CPU module by its programs.
Remote I/O station	Station where cyclic transmission of bit-by-bit input/output signals is performed with the master station
Remote device station	Station where cyclic transmission of bit-by-bit input/output signals and word-by-word input/output data is performed with the master station. The station returns a response to transient transmission (request) from other stations.
Intelligent device station	Station where cyclic transmission of bit-by-bit input/output signals and word-by-word input/output data is performed with the master station. Transient transmission can be also performed. The station returns a response to transient transmission (request) from other stations. The station also issues transient transmission (request) to other stations.
Slave station	Generic term for the stations other than the master station (local station, remote I/O station, remote device station, and intelligent device station)
Reserved station	Station that is not actually connected, but must be included in the total number of the stations on the network since it is to be connected in the future.
Relay station	Station that comprises of a programmable controller and multiple network modules and that relays data link communication to another network.
Cyclic transmission	A communication function by which data are periodically exchanged among stations on the same network, by using link devices (RX, RY, RWw, and RWr).
Transient transmission	A method for communication with another station, which is used when requested by a dedicated instruction or GX Works2.
Data link	Generic term for cyclic transmission and transient transmission
Routing	Process of selecting paths for communication with other networks. For the CC-Link IE Field Network, to communicate with stations on a different kind of network, configure communication paths with routing parameters in advance. For the head module, routing parameter setting is not required. Communications with other networks are performed by routing parameters of the master station.
Dedicated instruction	Instruction that facilitates programming for the functions of the intelligent function modules
Link dedicated instruction	Dedicated instruction that is used for transient transmission with a programmable controller on another station. This allows communications with not only the programmable controllers on the same network but also those on the other networks. In addition to the CC-Link IE Field Network, the Ethernet, CC-Link IE Controller Network, and MELSECNET/H are also accessible.
Reconnection	Operation that is performed to restart data link when a faulty station returns to normal.
Disconnection	Operation that is performed to stop data link when a data link error occurs.
Device	One of various devices (X, Y, W, etc.) inside the head module
Link device	One of various devices (RX, RY, RWr, RWw, etc.) inside a module on the CC-Link IE Field Network
Remote input (RX)	Bit data that is input from the slave station to the master station (with some exceptions for local stations)  User's manual for the master/local module used

Term	Description
Remote output (RY)	Bit data that is output from the master station to the slave station (with some exceptions for local stations)  User's manual for the master/local module used
Remote register (RWr)	16-bit data (word data) that is input from the slave station to the master station (with some exceptions for local stations)  User's manual for the master/local module used
Remote register (RWw)	16-bit data (word data) that is output from the master station to the slave station (with some exceptions for local stations)  User's manual for the master/local module used
Link special relay (SB)	Bit data that indicates the module operating status and data link status of the CC-Link IE Field Network
Link special register (SW)	16-bit data (word data) that indicates the module operating status and data link status of the CC-Link IE Field Network
Parameter memory	A flash ROM that is built in the head module and used for storing parameters of the head module.
Intelligent function module	A MELSEC-Q/L series module that has functions other than input and output, such as an A/D or D/A converter module.
Buffer memory	The memory of an intelligent function module, which is used to store data (such as setting values and monitored values) for communication with a CPU module.
RAS	Abbreviation for Reliability, Availability, and Serviceability. A generic term used to describe the easy use of automated equipment.
RIRD	Abbreviation for JP.RIRD and GP.RIRD Dedicated instruction to be used in a program of the master and local modules
RIWT	Abbreviation for JP.RIWT and GP.RIWT Dedicated instruction to be used in a program of the master and local modules

# PACKING LIST

---

The following items are included in the package of this product. Before use, check that all the items are included.

---

## LJ72GF15-T2

---

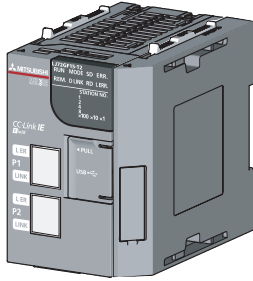

Head module + END cover (L6EC)

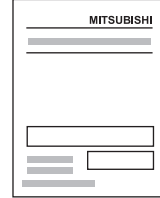

Safety Guidelines (IB-0800455)

---

# CHAPTER 1 HEAD MODULE

The head module can connect MELSEC-L series I/O modules and intelligent function modules on CC-Link IE Field Network.

The head module can be used as an intelligent device station on the CC-Link IE Field Network.

For CC-Link IE Field Network, refer to the following.

 Relevant master/local module user's manual

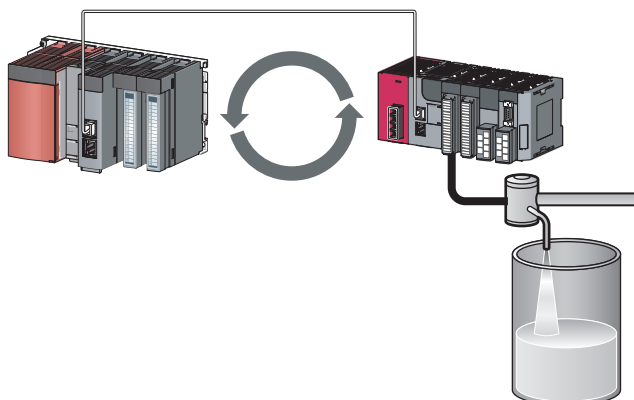

## (1) Cyclic transmission

The I/O signals of the module connected to the head module can operate as those of the master station.

( Page 65, CHAPTER 8)

For example, when the output (Y) of the master station is turned on, the output (Y) of the module connected to the head module turns on.

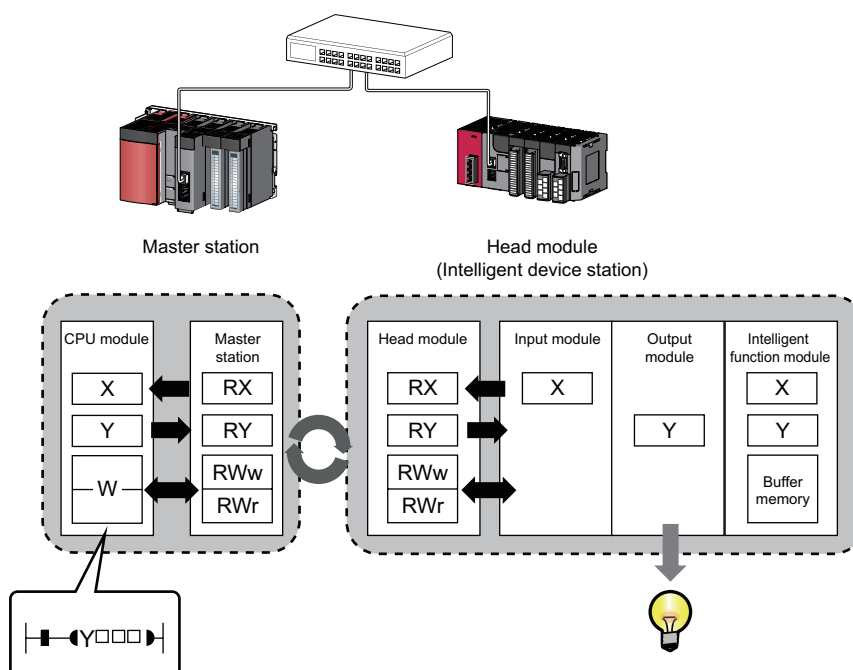

## (2) Transient transmission

The master station and a local station can directly access head module devices and the buffer memory in an intelligent function module by transient transmission. Communications with other stations on other networks can also be made.

The master station and a local station send requests to the head module by dedicated instructions.

(  Relevant master/local module user's manual)

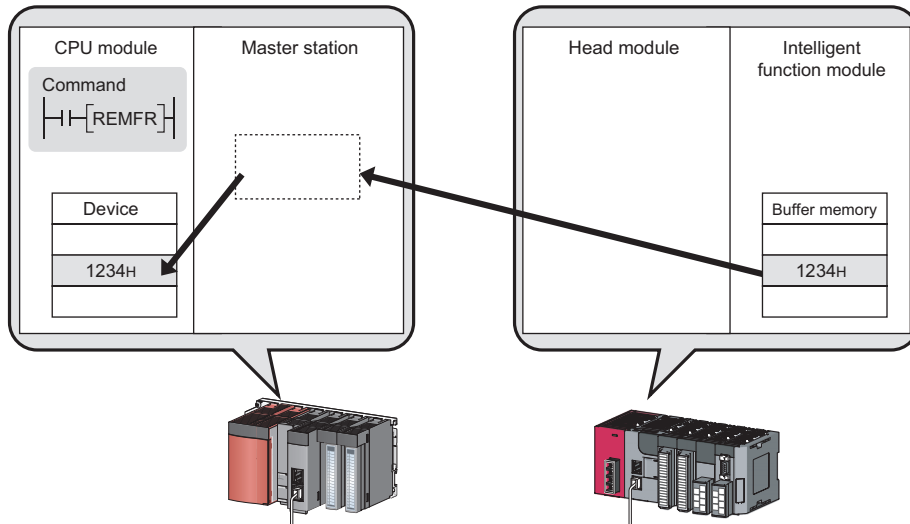

## (3) Setting parameters

Parameters for the head module can be set using software, GX Works2. Creating parameter setting programs is not necessary. (  Page 51, CHAPTER 7)

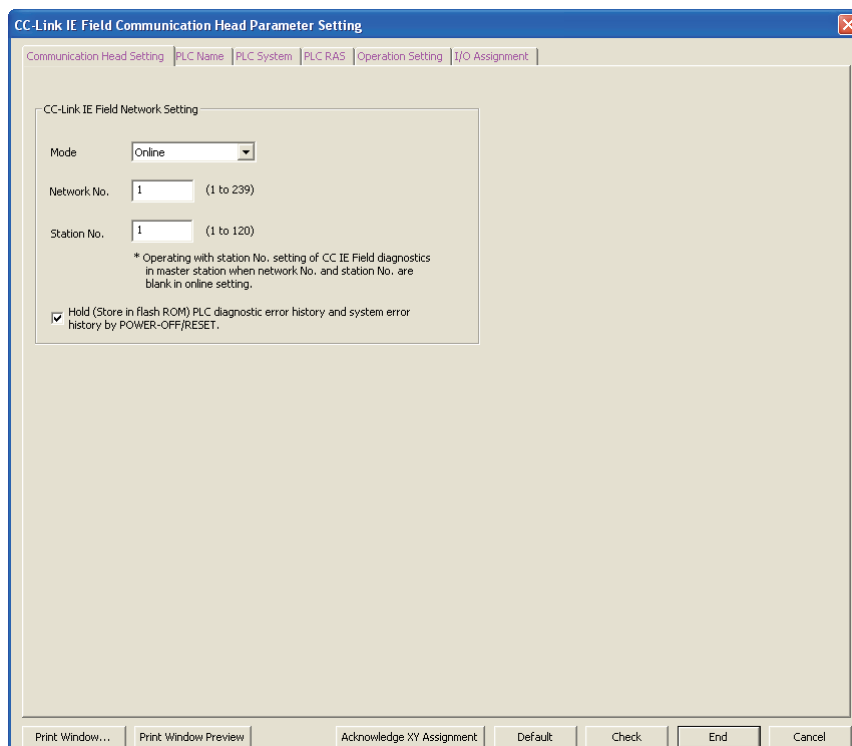

### (4) Diagnostics

GX Works2 facilitates diagnosing the head module and connected modules. (☞ Page 75, CHAPTER 9, Page 84, Section 11.2)

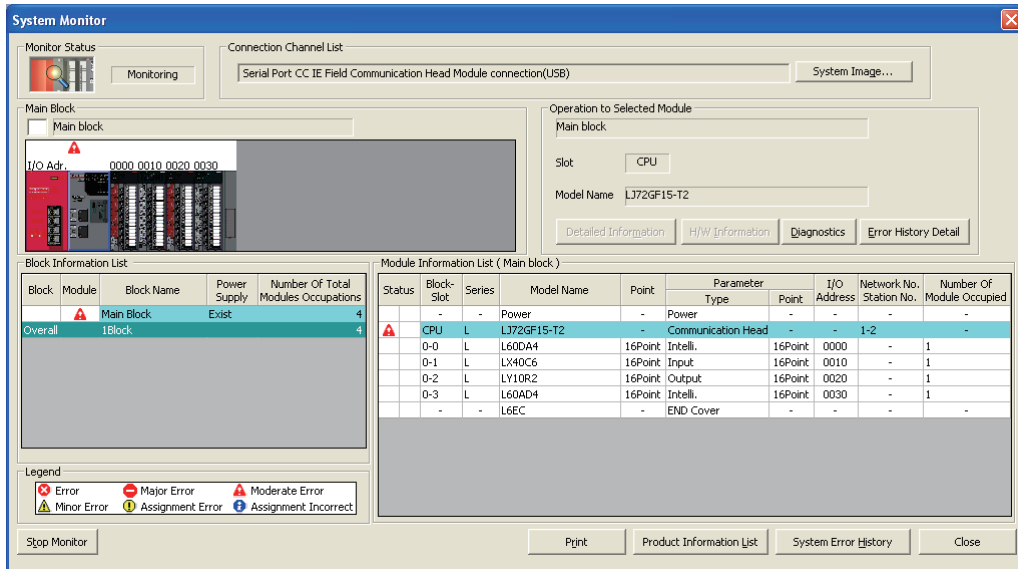

# CHAPTER 2 PART NAMES

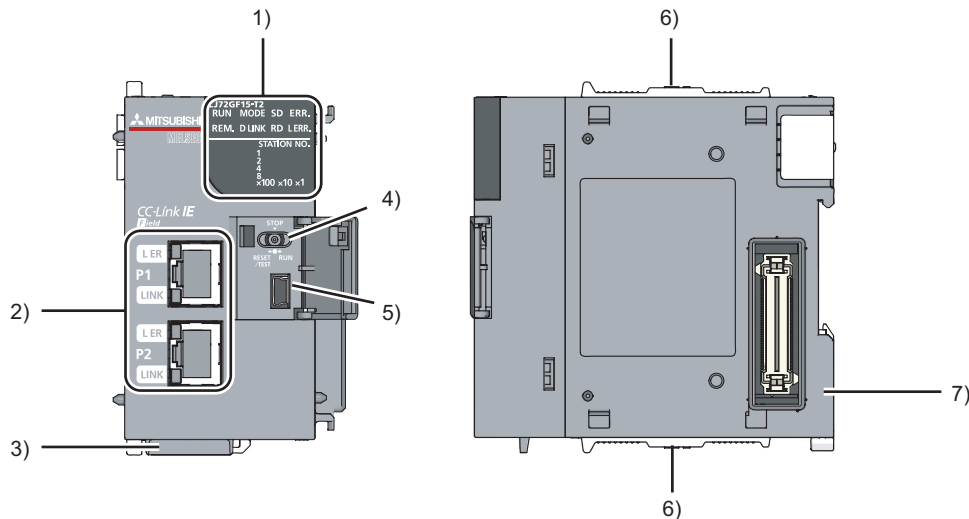

This chapter describes each part and name of the head module.



No.	Name	Description
1)	RUN LED	Indicates the operating status.
	On	Operating normally. (RUN status)
	Flashing	Working normally. (STOP status) <ul style="list-style-type: none"> <li>The switch of the head module is set to STOP. (Transfer between the devices in the head module is stopped.)</li> <li>The master station is in the STOP status. (Transfer between the devices in the head module is continued.)</li> <li>Accepting remote STOP request</li> <li>The head module has stopped due to an error (except a watchdog timer error).</li> </ul>
	Off	A hardware failure or a watchdog timer error has occurred.
	MODE LED	Indicates the mode.
	On	Online mode
	Flashing	Test mode
	Off	Offline mode
	REM. LED	Indicates the operating status of the own station.
	On	Operating normally.
	Flashing	Has not been reset after writing to PLC. Or, forced input/output registration is in progress.
	Off	The initial data are being processed, or an error has occurred in the own station.
	D LINK LED	Indicates the status of the data link.
	On	Data link in operation (cyclic transmission in progress)
	Flashing	Data link in operation (cyclic transmission stopped)
	Off	Data link not in operation (disconnected) or the module is in offline mode.
	SD LED	Indicates the send status of data.
	On	Sending data.
	Off	Data not sent.
	RD LED	Indicates the reception status of data.
	On	Receiving data.
Off	Data not received.	

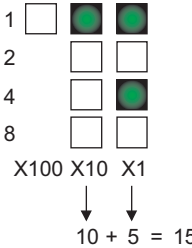

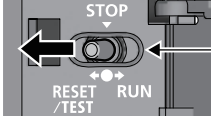
No.	Name	Description	
1)	ERR. LED	Indicates the error status of the head module. The error details can be confirmed in CC-Link IE Field Network diagnostics. (☞ Page 75, CHAPTER 9)	
		On	An error has occurred in the head module.
		Off	Working normally.
	L ERR. LED	Indicates the received data status. When this LED is on, you can check the L ER LED for "P1" or "P2" to see on which port the error was detected. The error details can be confirmed in CC-Link IE Field Network diagnostics. (☞ Page 75, CHAPTER 9) This LED automatically turns off when the module has received normal data or does not perform loopback in ring topology.	
		On	<ul style="list-style-type: none"> <li>The module has received abnormal data.</li> <li>The module is performing loopback (only the head module whose serial number (first five digits) is "12072" or later).</li> </ul>
		Off	<ul style="list-style-type: none"> <li>The module has received normal data.</li> <li>The module does not perform loopback (only the head module whose serial number (first five digits) is "12072" or later).</li> </ul>
STATION NO.	Displays the station number of the head module.		
	On	Displays the station number. <b>Ex.</b> Station No. 15 	
Off	The station number has not been set.		
2)	P1	PORT1 connector for CC-Link IE Field Network (RJ45 connector) Connect an Ethernet cable. (☞ Page 47, Section 6.5.1) There is no restriction on the order of connecting the "P1" and "P2" connectors.	
		L ER LED	On
	Off	<ul style="list-style-type: none"> <li>The module has received normal data.</li> <li>The module does not perform loopback (only the head module whose serial number (first five digits) is "12072" or later).</li> </ul>	
	LINK LED	On	Linkup in progress.
		Off	Linkdown in progress.
	P2	PORT2 connector for CC-Link IE Field Network (RJ45 connector) Connect an Ethernet cable. (☞ Page 47, Section 6.5.1) There is no restriction on the order of connecting the "P1" and "P2" connectors.	
L ER LED		(Same as the "P1" connector)	
LINK LED		(Same as the "P1" connector)	
3)	Serial number display	Displays the serial number printed on the rating plate.	

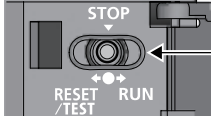
No.	Name	Description
4)	Switch	This switch controls the operation of the head module.
	RESET/TEST	<p>Resets the head module or switches it to test mode. Operate the switch with your fingers. Use of a tool such as a screw driver may damage the switch.</p> <ul style="list-style-type: none"> <li>Reset method</li> </ul> <div style="display: flex; align-items: center;">  <div style="margin-left: 20px;">Switch</div> </div> <div style="margin-top: 10px;">  <div style="margin-left: 20px;"> <span style="border: 1px solid black; padding: 2px;">ERR.</span> : Flashing  <span style="border: 1px solid black; padding: 2px;">ERR.</span> : Flashes several times and then turns off.         </div> </div> <div style="margin-top: 10px;">  <div style="margin-left: 20px;">Switch</div> </div> <ol style="list-style-type: none"> <li><b>1. Hold the switch in the RESET/TEST position for 1 second or more.</b> Do not release your hand from the switch while it is in the RESET/TEST position.</li> <li><b>2. Check that the ERR. LED flashes several times and then turns off.</b></li> <li><b>3. Set the switch to the STOP position.</b> The switch automatically returns to the STOP position when your hand is released.</li> </ol> <ul style="list-style-type: none"> <li>Test method For details on the test mode, refer to the explanation on the test mode. (☞ Page 45, Section 6.4)</li> </ul>
	STOP*1	<p>Stops the data transfer between the link devices of the head module (cyclic data from the master station) and head module devices. (Stops the transfer while performing cyclic transmission with the master station, and turns the output OFF.) By stopping the data transfer, you can keep the input/output of the module attached to the head module from getting sent to the master or local station. The STOP switch is used when performing a debug operation between modules attached to the head module and external devices.</p> <p><b>Ex.</b> Debugging with an external device using the STOP switch</p> <ol style="list-style-type: none"> <li>(1) Set the switch to "STOP".</li> <li>(2) Data transfer is stopped between the link devices of the head module and the head module devices, and the devices are separated from the master station control.</li> <li>(3) Perform an input/output test between the module connected to the head module and the external device. Since the data transfer is stopped, the input/output status data are not sent to the master or the local station.</li> <li>(4) When the test is complete, write the parameter to the head module and start the system operation.</li> </ol>
RUN	<p>Starts the data transfer between the link devices of the head module (cyclic data from the master station) and the head module devices. The output from the master station is output from the module connected to the head module. The input from the module attached to the head module is input to the master station.</p>	
5)	USB connector	A connector for connecting to GX Works2. (Connector type: miniB)
6)	Module joint levers	Levers for connecting modules each other.
7)	DIN rail hook	A hook used to mount the module to a DIN rail.

\*1 Even if the switch is set to "STOP", the master station will indicate that a cyclic transmission is being performed in the head module.

**Remark**

- Opening and closing the front cover of the head module  
The cover on the front of the head module is equipped with a stopper. If you open the cover until it clicks, it will stay open.

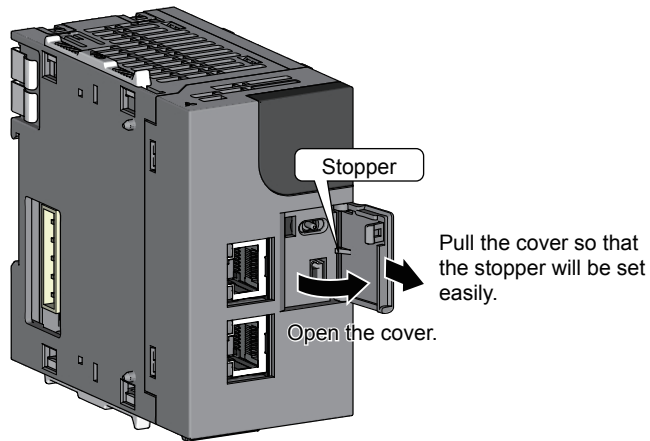

- LED indication during a line test  
The following LEDs flash while a circuit test is performed from the master station.
  - MODE LED
  - D LINK LED
  - × 100 LED

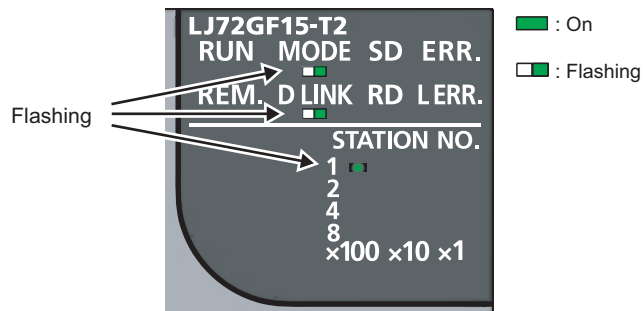

For information on how to perform a line test, refer to the following.

 User's manual for the master/local module used

# CHAPTER 3 SPECIFICATIONS

This chapter describes the specifications of the head module.

## 3.1 General Specifications

Item	Specifications					
Operating ambient temperature	0 to 55°C					
Storage ambient temperature	-25 to 75°C					
Operating ambient humidity	5 to 95%RF, non-condensing					
Storage ambient humidity						
Vibration resistance	Compliant with JIS B 3502 and IEC 61131-2		Frequency	Constant acceleration	Half amplitude	Sweep count
		Under intermittent vibration	5 to 8.4Hz	-	3.5mm	10 times each in X, Y, and Z directions
			8.4 to 150Hz	9.8m/s <sup>2</sup>	-	
		Under continuous vibration	5 to 8.4Hz	-	1.75mm	-
8.4 to 150Hz	4.9m/s <sup>2</sup>		-			
Shock resistance	Compliant with JIS B 3502 and IEC 61131-2 (147m/s <sup>2</sup> , 3 times each in X, Y, and Z directions)					
Operating atmosphere	No corrosive gases					
Operating altitude* <sup>1</sup>	0 to 2000m					
Installation location	Inside a control panel					
Overvoltage category* <sup>2</sup>	II or less					
Pollution degree* <sup>3</sup>	2 or less					
Equipment class	Class I					

\*1 Do not use or store the programmable controller under pressure higher than the atmospheric pressure of altitude 0m. Doing so may cause malfunction. When using the programmable controller under pressure, please consult your local Mitsubishi Electric representative.



\*2 This indicates the section of the power supply to which the equipment is assumed to be connected between the public electrical power distribution network and the machinery within premises.  
Category II applies to equipment for which electrical power is supplied from fixed facilities. The surge voltage withstand level for up to the rated voltage of 300V is 2500V.

\*3 This index indicates the degree to which conductive material is generated in terms of the environment in which the equipment is used.  
Pollution level 2 is when only non-conductive pollution occurs. A temporary conductivity caused by condensing must be expected occasionally.

### Point

To make the programmable controller comply with the EMC and Low Voltage Directives, refer to  Page 149, Appendix 10.

## 3.2 Performance Specifications

Item		Specifications
CC-Link IE Field Network		-
Maximum link points per network	RWw	8192 points, 16KB
	RWr	8192 points, 16KB
	RX	16384 points, 2KB
	RY	16384 points, 2KB
Maximum link points per station	RWw	1024 points, 2KB
	RWr	1024 points, 2KB
	RX	2048 points, 256 bytes
	RY	2048 points, 256 bytes
Station No.		1 to 120
Network No.		1 to 239
Communication method		Token passing method
Ethernet		-
Communication speed		1Gbps
Network topology		Line topology, star topology (Coexistence of both line topology and star topology is possible.), ring topology
Connection cable		An Ethernet cable that meets the 1000BASE-T standard: Category 5e or higher (double shielded, STP), straight cable (  User's manual for the master/local module used)
Maximum station-to-station distance		100m max. (ANSI/TIA/EIA-568-B (complies with Category 5e)) (  Page 50, Section 6.5 (5))
Overall cable distance		Line topology: 12000m (when connecting 1 master station and 120 slave stations) Star topology: Depends on the system configuration Ring topology: 12100m (when connected to 1 master station and 120 slave stations)
Number of cascade connections		Up to 20
Head module		-
Number of I/O points	X	4096 points, 512 bytes (Number of points accessible to the actual module)* <sup>1</sup>
	Y	4096 points, 512 bytes (Number of points accessible to the actual module)* <sup>1</sup>
Number of device points	X	8192 points, 1KB (number of usable points on the program) (RX0 is assigned from X0.)
	Y	8192 points, 1KB (number of usable points on the program) (RY0 is assigned from Y0.)
	W	8192 points, 16KB (1024 points from W0 to W3FF are assigned from RWw0. 1024 points from W1000 to W13FF are assigned from RWr0.)
	SB	8192 points, 1KB (SB0000 to SB0FFF are used by the system. SB1000 to SB1FFF can be modified by the user.)
	SW	8192 points, 16KB (SW0000 to SW0FFF are used by the system. SW1000 to SW1FFF can be modified by the user.)
	SM	2048 points, 256 bytes
	SD	2048 points, 4KB
	U□□G□□	Device that directly accesses the buffer memory of the intelligent function module (  User's manual for the intelligent function module used)
Number of writes to the parameter memory		Up to 100000 times

Item		Specifications
Maximum number of intelligent function module parameters	Initial setting	4096
	Auto refresh	2048
Clock function (for displaying the date and time of error)		<p>Year, month, date, hour, minute, and second (with automatic leap year detection)</p> <p>When connected to the network, the clock synchronizes periodically with the clock in the CPU module of the master station via the network. (Initial value: 2000/1/1 00:00:00)</p> <p>After the clock information has been acquired from the master station, when the head module power supply is switched OFF and then ON, the clock resumes from the time when the power was last turned OFF. (The clock does not run while the power is OFF.)</p> <p>Therefore, the data and time of an error that occurred during initial processing may be different from the actual one.</p>
Allowable momentary power failure time		Depends on the power supply module used.
Internal current consumption (5VDC)		1.0A
External dimensions	H	90mm
	W	50mm
	D	95mm
Weight		0.23kg

\*1 This is the maximum number of points that can be assigned to the actual module in "PLC Parameter" - "I/O Assignment" of GX Works2.

## 3.3 Function List

The functions of the head module are listed below.

Function	Description	Reference
Cyclic transmission	The inputs/outputs of the module connected to the head module can be handled just like those of the master station.	Page 65, CHAPTER 8
Transient transmission	Head module devices and the buffer memory of the intelligent function module can be accessed directly from the master and local stations. Transient transmission also enables the communication with another network.  Requests from the master or local station to the head module are made with dedicated instructions. (  User's manual for the master/local module used)	Manual for the master/local module
Output mode setting for error	Specifies whether to clear or hold the output to each module when a stop error or a data link error occurs in the head module.	Page 61, Section 7.1 (6)
Operation mode setting for a hardware error	Specifies whether to stop the auto refresh of the head module or not, when a hardware error occurs (when the head module detects SP.UNIT DOWN) in the intelligent function module.	Page 61, Section 7.1 (6)
File Password 32	A read password and a write password can be set to files stored in the head module.	Page 113, Appendix 2
Remote password	Prevents unauthorized access from external devices, using a serial communication module connected to the head module.	Page 63, Section 7.3
Diagnostics	Diagnostics of the head module and connected modules can be performed using GX Works2.	Page 75, CHAPTER 9 Page 84, Section 11.2
System error history	The history of errors that occurred in the head module and intelligent function modules can be confirmed on a single screen.	Page 89, Section 11.3
Remote RUN/STOP	Changes the status of the head module to RUN or STOP, without using the switch.	Page 81, Section 9.7
Remote RESET	Resets the head module when it is in the STOP status, without using the switch.	Page 81, Section 9.7
Monitoring/test	The status of the head module devices and the buffer memory of the intelligent function module can be monitored, and current values can be changed in GX Works2. Use one of the following to monitor or change the current value. <ul style="list-style-type: none"> <li>• Device/buffer memory batch monitor</li> <li>• Watch window</li> <li>• Present value change</li> </ul>	GX Works2 operating manual
Forced on/off of external input/output	The external input/output of the head module can be forcibly turned on or off.	Page 110, Appendix 1
Station number setting from master station	A station number can be set for a head module from the CC-Link IE Field Network diagnostics of the master station.	Page 32, Section 4.2

# CHAPTER 4 PROCEDURES BEFORE OPERATION

This chapter explains the procedures before operating the head module.

## 4.1 Initial Start-up Procedure

The following is the start-up procedure using the head module for the first time.

For start-up examples, refer to the  User's manual for the master/local module used.

Check box

### System consideration

Consider the system configuration and link device assignments.



Page 35, CHAPTER 5,  
Page 65, CHAPTER 8



### Installation

Install the power supply module, head module, I/O module(s), intelligent function module(s), and an END cover.



Page 37, Section 6.1,  
Page 38, Section 6.2,  
Page 45, Section 6.3



### Unit test

Perform unit tests on the head module and intelligent function module(s).



Page 45, Section 6.4



### Connection

Connect Ethernet cables to the head module.



Page 47, Section 6.5



### Configuration

Set parameters for each module.



Page 51, CHAPTER 7,  
Page 65, CHAPTER 8



To the next page



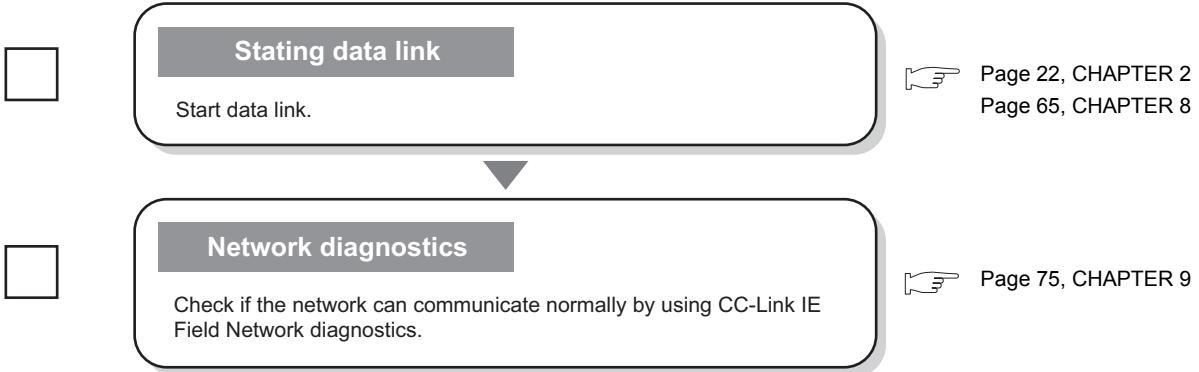

**Point** 

If the head module is powered on when there is no communication with the master station, it takes approximately 5 seconds to change to the RUN status.

## 4.2 Procedure for Changing the Head Module

The head module can be changed without stopping the data link in the system.

Even if the head module does not have a station number, it can be assigned from CC-Link IE Field Network diagnostics of the master station.

### (1) Procedure

Check box

#### Link stop and temporary error invalid station setting

Stop the link at the master station, and set the intelligent device station to be replaced as a temporary error invalid station.

 User's manual for the master/local module used



#### Cable disconnection

Turn off the power, and disconnect the Ethernet cables from the head module.

 Page 47, Section 6.5



#### Head module replacement

Replace the head module.

 Page 43, Section 6.2.3



#### Cable connection

Connect Ethernet cables to the head module, and power it on.

 Page 47, Section 6.5



#### Station No. setting

Set a unique station No. for the head module so that duplication will not be detected in CC-Link IE Field Network diagnostics from the master station.

 Page 34, Section 4.2 (3)



#### Parameter setting

Change the connection destination of GX Works2 to the head module, and set the network No., station No. and the parameter of each module.

 Page 51, CHAPTER 7,  
Page 65, CHAPTER 8



To the next page

Check box

**Setting the head module into RUN status**

Set the switch of the head module to "RUN".

 Page 22, CHAPTER 2**Temporary error invalid station cancel and link start**

Cancel the temporary error invalid station setting on the master station, and start the link.

 User's manual for the master/local module used**Network diagnostics**

By CC-Link IE Field Network diagnostics, check if communication is normal.

 Page 75, CHAPTER 9**(2) Precautions****(a) Setting a station number from the master station using the CC-Link IE Field Network diagnostics**

- The network number will be the same as that of the master station.
- The network number and the station number can be checked by Station No. set for diagnostics (SW004E and SW004F).
- When a network number and a station number are set in the "Communication Head Setting" tab in the PLC Parameter dialog box, the parameter settings take priority.
- When the station set in the "Communication Head Setting" tab is operating, Operating station number status (SB004F) turns off.

When the station set by the CC-Link IE Field Network diagnostics is operating, Operating station number status (SB004F) turns on.

**(b) Changing a station number from the master station using the CC-Link IE Field Network diagnostics**

Use the following module and GX Works2.

- Master/local module whose serial number (first five digits) is "13032" or later
- GX Works2 with Version 1.53F or later

If using a master/local module or GX Works2 not meeting the above condition, perform the following operation with GX Works2 connected to the head module, clear the station number, and reset the head module's station number.

1. Leave the "Network No." and "Station No." fields blank in the "Communication Head Setting" tab in the PLC Parameter dialog box. ( Page 53, Section 7.1 (1))
2. Execute "Format PLC Memory" on the head module using GX Works2.
3. Write PLC parameters to the head module.
4. Reset the head module or power off and on the module.

### (3) Example of changing the head module:

1. In GX Works2, read the parameters written in the head module into a GX Works2 project by selecting "Read from PLC".  
 [Online] ⇨ [Read from PLC]
2. Connect GX Works2 to the master station, and stop the data link from CC-Link IE Field Network diagnostics.
3. From CC-Link IE Field Network diagnostics, set the head module as a temporary error invalid station.
4. Change the head module.

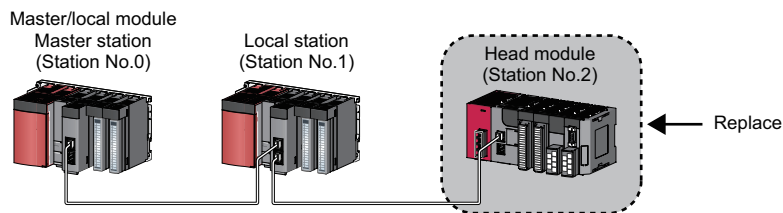

5. If the new head module does not have a station number assigned to it, connect GX Works2 to the master station, and assign a station number to the head module from CC-Link IE Field Network diagnostics.

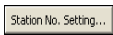
 [Diagnostics] ⇨ [CC-Link IE Field Diagnostics] ⇨ select the head module with station No. not set in "Network Status" ⇨ click the  button.

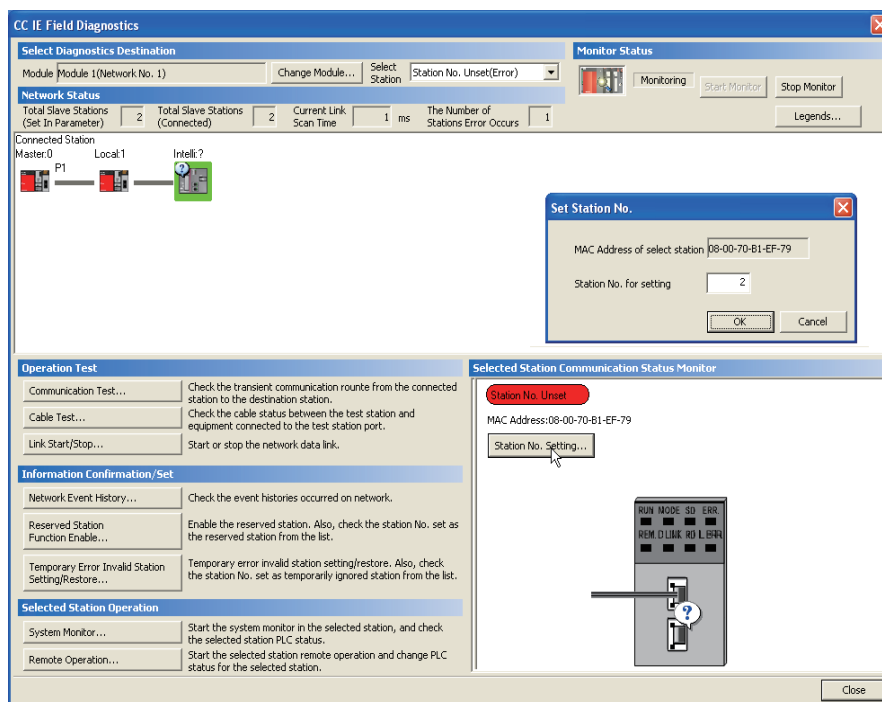

6. Write the parameters read in step 1 to the new head module.  
 The written parameters are reflected when the power is switched off and then on, or when the head module is reset.

 [Online] ⇨ [Write to PLC]

7. Move the head module switch to "RUN".
8. Clear the temporary error invalid station setting configured in step 3.

# CHAPTER 5 SYSTEM CONFIGURATION

This chapter describes system configuration using a head module. For CC-Link IE Field Network configuration, refer to the following.

 Relevant master/local module user's manual

## 5.1 Head Module System Configuration

The following shows system configuration using a head module.

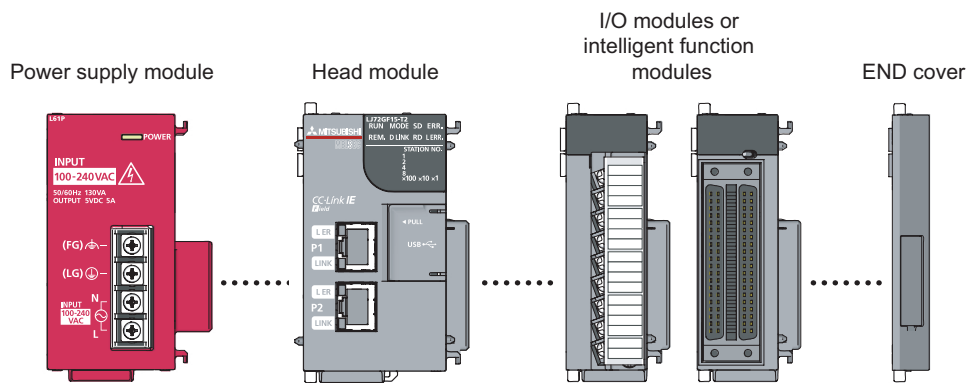

For power supply modules, refer to the following.

 MELSEC-L CPU Module User's Manual (Hardware Design, Maintenance and Inspection)

For I/O modules and intelligent function modules, refer to the manual for the relevant modules.

**Point** 

The MELSEC-L series CPU module cannot be connected to a system using a head module.

## 5.2 Applicable Systems

### (1) Connectable modules and the number of modules

#### (a) Connectable modules

MELSEC-L series modules can be connected to the head module.

However, there are some modules that can be connected with restrictions or that can be connected but cannot be used.

#### (b) Number of modules

The number of I/O modules and intelligent function modules that can be connected is 10 in total.<sup>\*1\*2</sup>

\*1 The number of modules is exclusive of the number of power supply modules and END covers.

\*2 For some intelligent function modules, one module occupies a space by two modules. For the occupied space, refer to the user's manual for the module used before configuring a system.

Some modules have restrictions on the number of modules. The following table shows the relevant models and the number of modules.

Module	Model	Number of modules
Head module	LJ72GF15-T2	1
CC-Link system master/local module	LJ61BT11	Up to 4

### (2) Modules/unit that cannot be connected

The CPU module and the following module/unit cannot be connected to the head module.

Module/unit	Model
Branch module	L6EXB
Extension module	L6EXE
RS-232 adapter	L6ADP-R2
Display unit	L6DSPU
L series CC-Link IE Field Network master/local module	LJ71GF11-T2

- Positioning modules and simple motion modules cannot be connected to the head module whose serial number (first five digits) is "12071" or earlier.

### (3) Software package

GX Works2 is required for setting and diagnosing the head module.

GX Developer is not available.

Software	Version
GX Works2	Version 1.31H or later

### (4) Precautions for system configuration

#### (a) Rated output current (5VDC)

Configure a system so that the total current consumption may not exceed 5VDC, rated output current of the power supply module. For specifications of the power supply module, refer to the following.

 MELSEC-L CPU Module User's Manual (Hardware Design, Maintenance and Inspection)

# CHAPTER 6 INSTALLATION AND WIRING

This chapter describes the installation and wiring of modules.

## 6.1 Wiring Environment and Installation Position

When installing the module in a control panel, fully consider its operability, maintainability, and environmental resistance.

### 6.1.1 Installation environment

Install the programmable controller according to the installation environment shown in the general specifications.

(☞ Page 26, Section 3.1)

Do not install the programmable controller to the place where:

- Ambient temperature is outside the range of 0 to 55°C;
- Ambient humidity is outside the range of 5 to 95%RH;
- Condensation occurs due to rapid temperature change;
- Corrosive gas or combustible gas is present;
- Conductive powder such as dust and iron powder, oil mist, salinity, or organic solvent is filled;
- The programmable controller is exposed to direct sunlight;
- A strong electric field or strong magnetic field is generated; and
- The programmable controller is subject to vibration and shock.

### 6.1.2 Installation position

To ensure good ventilation and ease module change, provide clearance between the module top/bottom and structures/parts as shown below.

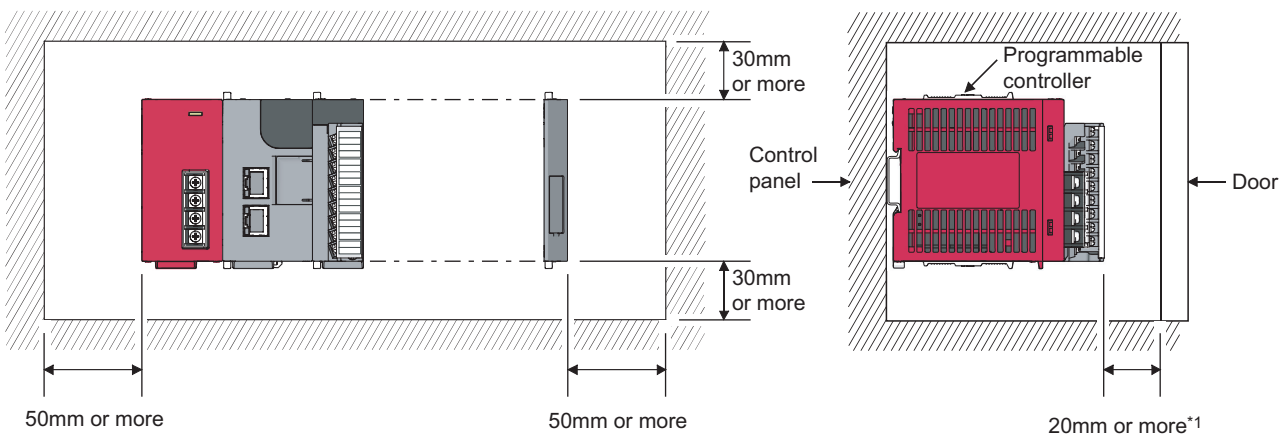

\*1 When using connectors for external devices, provide clearance of 80mm or more.

## 6.2 Installation

---

This section describes how to interconnect modules and how to mount them on a DIN rail.

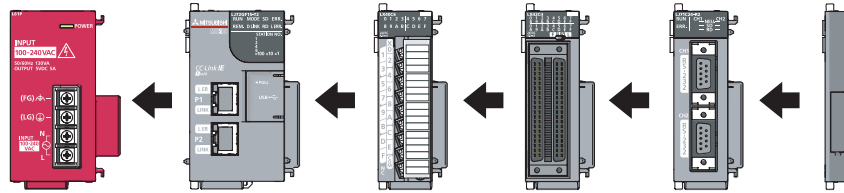

---

### *Point*

- Modules must be mounted on a DIN rail.
  - Connect an END cover on the right of the terminal module.
- 

### (1) Precautions for connecting and mounting modules

- Do not directly touch any conductive parts and electronic components of the module. Doing so can cause malfunction or failure of the module.
- The number of times the module can be connected/disconnected is limited to 50 times. (In accordance with IEC 61131-2) Exceeding this limit may cause malfunction.
- Do not drop or apply strong shock to the module case.
- Do not remove the printed-circuit board of the module from the case. Doing so may cause failure of the module and/or printed-circuit board.



## 6.2.1 Connecting modules

This section describes the procedure for connecting modules.

An example will show how a head module is connected to the L61P.

Shut off the external power supply for the system in all phases before connecting or disconnecting modules.

### (1) Connecting modules

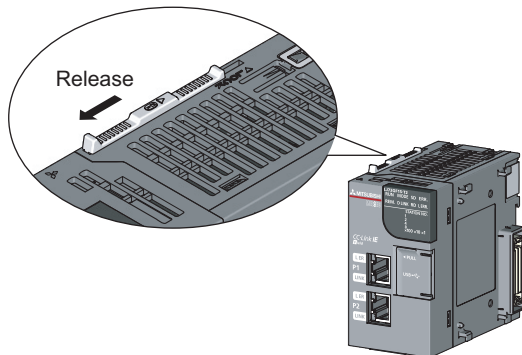

- 1. To release the module joint levers located at the top and bottom of the head module:**

Slide the levers toward the front side of the module.

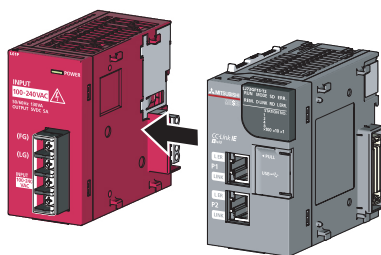

- 2. Insert the connector of the power supply module into that of the head module so that they are securely engaged.**

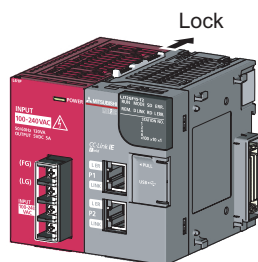

- 3. To lock the module joint levers:**

Slide the levers toward the back side of the module.

Make sure that the modules are securely connected.

### (2) Disconnecting modules

Disconnect the modules by reversing the procedure above.

#### **Point**

- Failure to securely lock the module joint levers may cause malfunction, failure, or drop of the module.
- The metal on the back of the module may be at a high temperature immediately after the module is powered off. Take care to prevent a burn at module disconnection.

## 6.2.2 Mounting the modules on a DIN rail

This section describes a procedure for mounting the modules on a DIN rail.

### (1) Mounting procedure

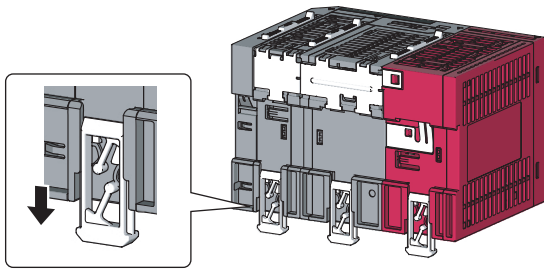

- 1. Pull down all DIN rail hooks on the back of the modules.**

The levers should be pulled down until you hear them click.

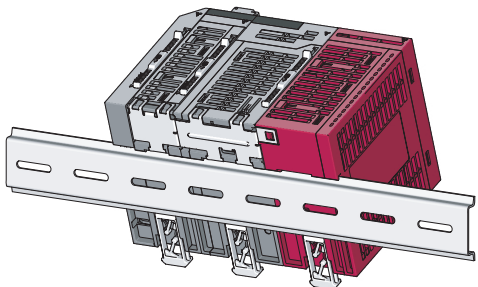

- 2. Hang the upper tabs of the modules on a DIN rail, and push the modules in position.**

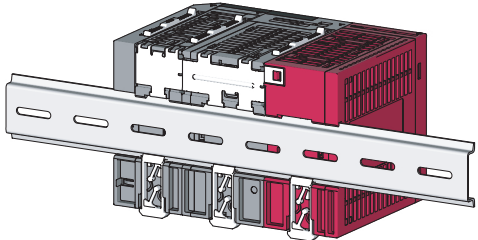

- 3. Lock the DIN rail hooks to the DIN rail to secure the modules in position.**

Push each hook up until you hear it click.

If the hooks are beyond the reach, use a tool such as a driver.

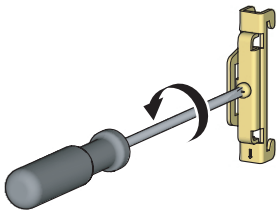

- 4. Loosen the screw on DIN rail stopper.**

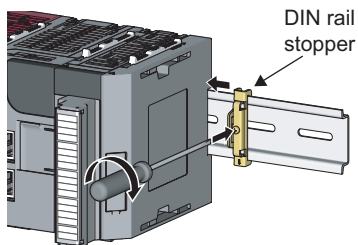
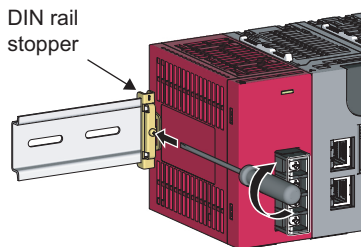
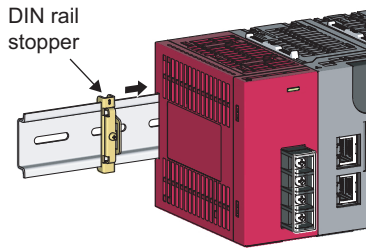
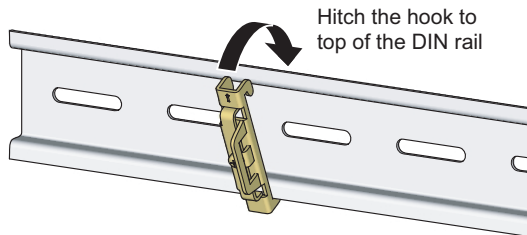
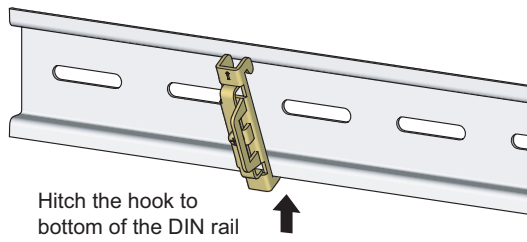

**5. Hitch the bottom hook of the DIN rail stopper to the bottom of the DIN rail.**

Hitch the hook according to the orientation of the arrow on the front of the stopper.

**6. Hitch the upper hook of the DIN rail stopper to the top of the DIN rail.**

**7. Slide the DIN rail stopper up to the left side of the modules.**

**8. Tighten the screw on the DIN rail stopper with a driver.**

**9. Attach a DIN rail stopper on the right of the modules with the same procedure.**

Do not slide modules from the edge of the DIN rail when mounting them. Doing so may damage the metal part located on the back of the module.

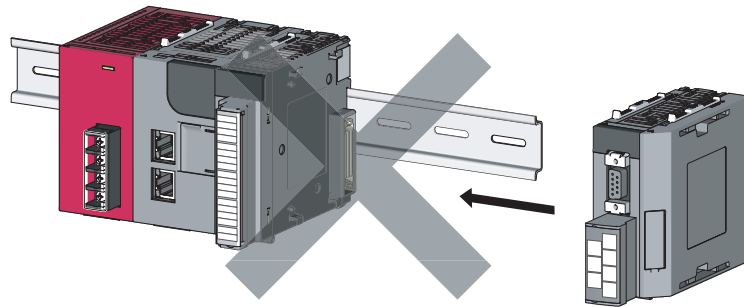

## (2) Removal procedure

Remove the modules from the DIN rail by reversing the above procedure.

## (3) Applicable DIN rail model (IEC 60715)

- TH35-7.5Fe
- TH35-7.5Al
- TH35-15Fe

## (4) DIN rail stopper

Use a stopper that is attachable to the DIN rail.

## (5) Interval between DIN rail mounting screws

To ensure the strength of a DIN rail, tighten DIN rail mounting screws (obtained by user) within 30mm away from the both edges of the DIN rail and at 200mm-interval between the screws.

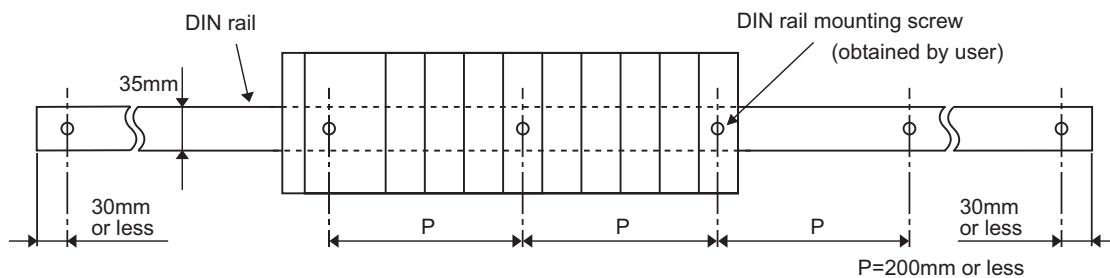

## 6.2.3 Changing modules on a DIN rail

This section describes a procedure for changing modules on a DIN rail by sliding them rightward. Remove the mounted terminal block and disconnect the connectors beforehand.

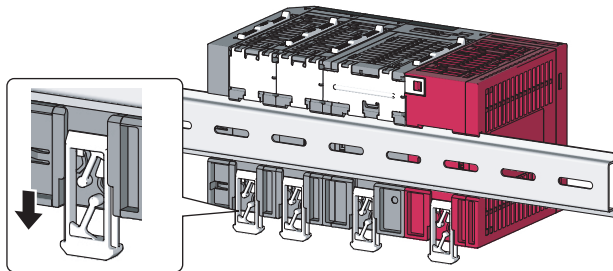

1. Remove the DIN rail stopper on the right edge.
2. Pull down DIN rail hooks on the back of the modules.

Pull down the DIN rail hooks on the module to be changed and the module on its right, until you hear them click.

If the hooks are beyond the reach, use a tool such as a driver.

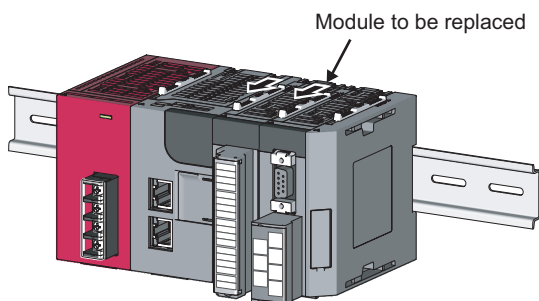

3. Release the module joint levers on the modules.

Release the levers on the module to be changed and on the module on the right of the changed module.

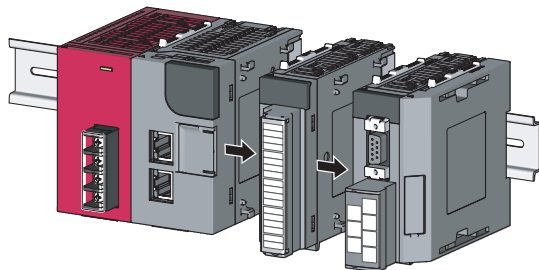

4. Disconnect the modules by sliding them individually.

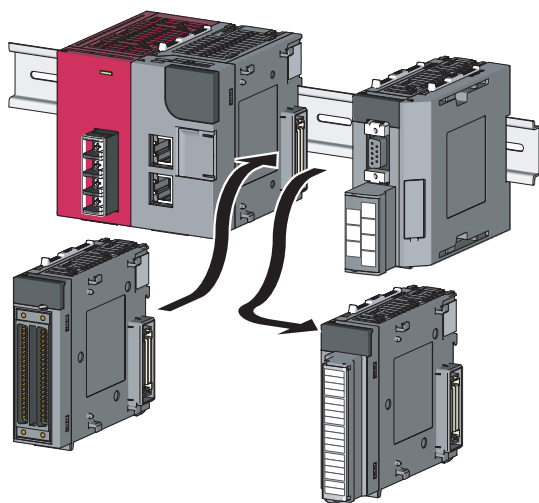

5. Change the modules.

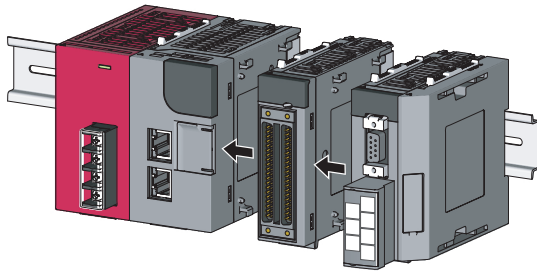

**6. Slide the modules and plug the connectors.**

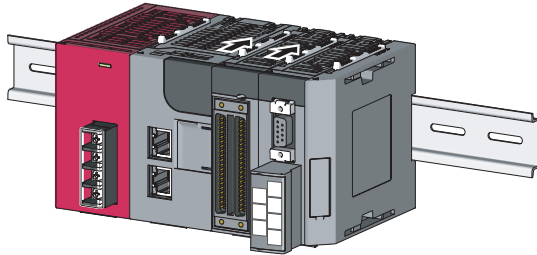

**7. Lock the module joint levers.**

**8. Lock the DIN rail hooks and attach the DIN rail stopper.**

( Page 40, Section 6.2.2)

**Point!**

Do not slide modules from the edge of the DIN rail when mounting them. Doing so may damage the metal part located on the back of the module.

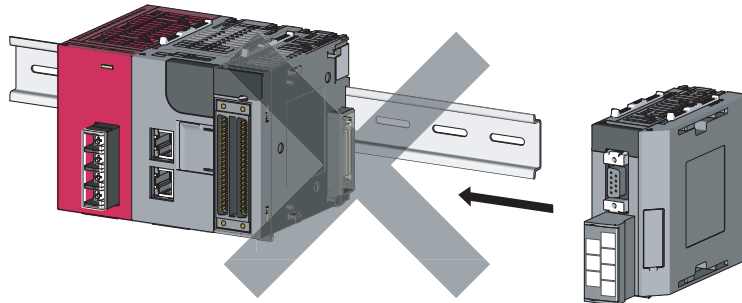

## 6.3 Wiring to the Power Supply Modules

For information on wiring to the power supply modules, refer to the following.

 MELSEC-L CPU Module User's Manual (Hardware Design, Maintenance and Inspection)

## 6.4 Testing the Head Module Before Wiring

### (1) Unit test

Run a unit test to check if there is any abnormality in the head module hardware.

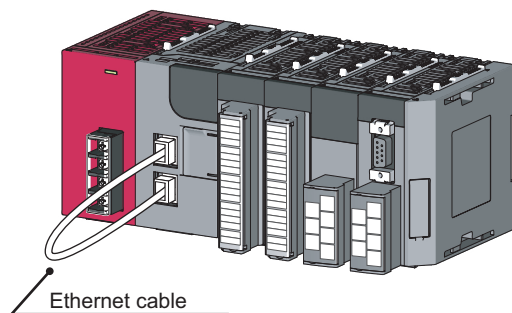

Repeat at intervals of less than 1s.

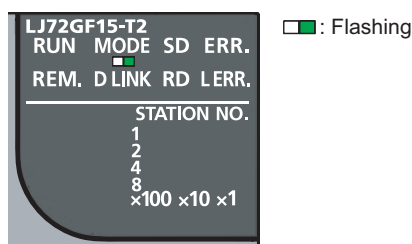
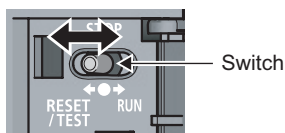

1 second or more

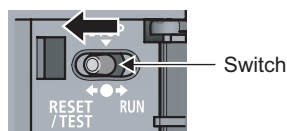

1. Power off the head module.
2. Connect the PORT1 and PORT2 of the head module with an Ethernet cable.

3. Power on the head module.
4. Using the switch on the head module, repeat 3 cycles of STOP→RESET/TEST→STOP, taking less than 1 second per cycle. (The MODE LED flashes after the 3rd cycle.)

5. Hold the switch on the front of the head module in the RESET/TEST position for 1 second or more.

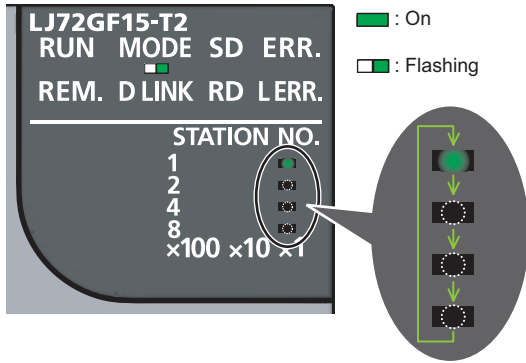

## 6. Unit test begins.

The MODE LED starts flashing, and the ×1 or ×10 LED starts turning on and off repeatedly in the sequence 1→2→4→8→1... and so on.

When completed

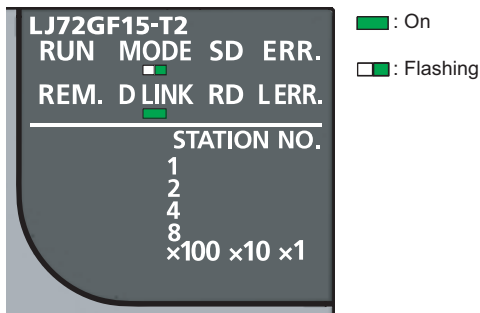

## 7. The ×1 or ×10 LED stops turning on and off, and the D LINK LED turns on when the test is completed.

- When completed  
The D LINK LED turns on, and the ERR. LED remains off.
- When failed  
The following LEDs turn on.
  - Either the ×1 or ×10 LED
  - ERR. LED
  - D LINK LED

If the test fails, replace the Ethernet cable and run the test again. If the test fails again, it may be due to a hardware failure in the head module. Please consult your local Mitsubishi service center or representative, with a detailed explanation of the problem.

When failed

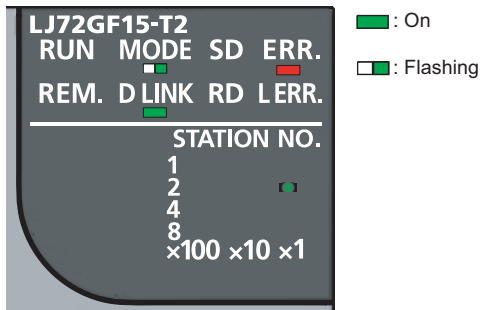



## 6.5 Wiring to the Head Module

This section describes the wiring to the head module.

### 6.5.1 Wiring

This section describes cable wiring and precautions. For network configuration, cables, and hubs for wiring, refer to the following.

 User's manual for the master/local module used

#### (1) Connecting the Ethernet cable

##### (a) Connecting the cable

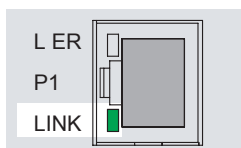
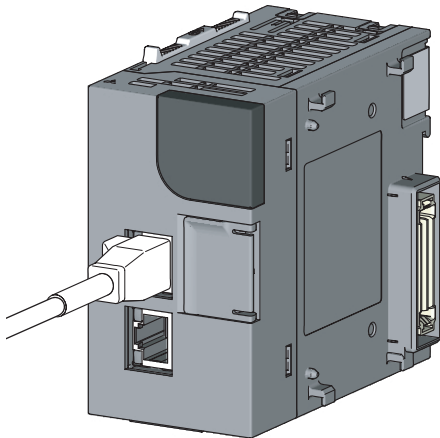

1. Power off the programmable controller.
2. Push the Ethernet cable connector into the head module until it clicks. Pay attention to the connector's direction.
3. Power on the head module.
4. Power on the external devices connected to PORT1 and PORT2 of the head module.
5. Check if the LINK LED on the port into which the Ethernet cable is connected is on. The LINK LED may take a few seconds to turn on after power-on. If the LINK LED does not turn on, refer to the troubleshooting section and take a corrective action. (👉 Page 91, Section 11.4)

It is not necessary to distinguish between PORT1 and PORT2.

- When using only one connector in star topology, either PORT1 or PORT2 can be connected.

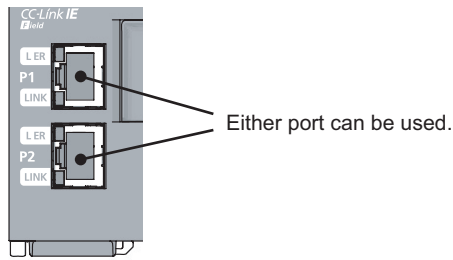

- When using two connectors for line topology and ring topology, an Ethernet cable can be connected to the connectors in any combination. For example, the cable can be connected between PORT1s and between PORT1 and PORT2.

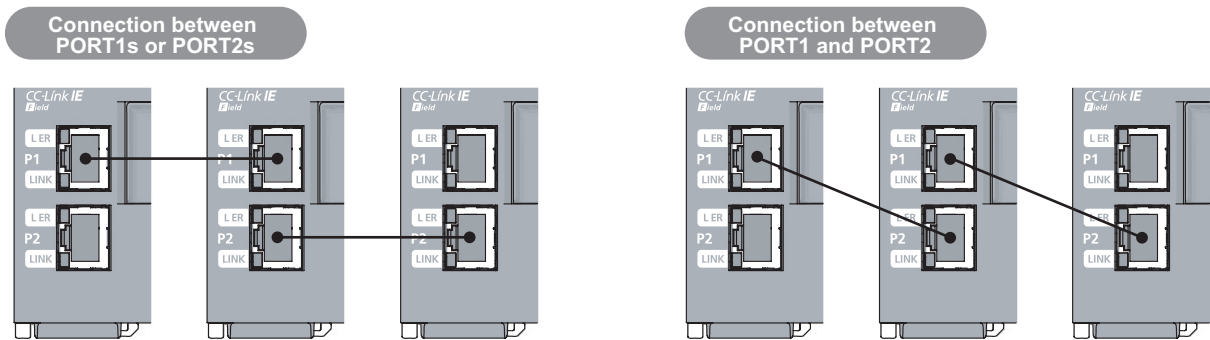

**(b) Disconnecting the cable**

1. Power off the programmable controller.
2. Press the latch down and unplug the Ethernet cable.

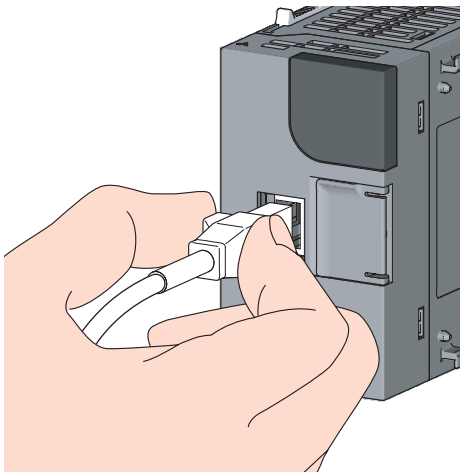

## 6.5.2 Grounding

Observe the following:

- Provide independent grounding when possible. Ground the FG and LG terminals to the protective ground conductor dedicated to the programmable controller.
- If independent grounding cannot be provided, employ (2) Shared grounding shown below.

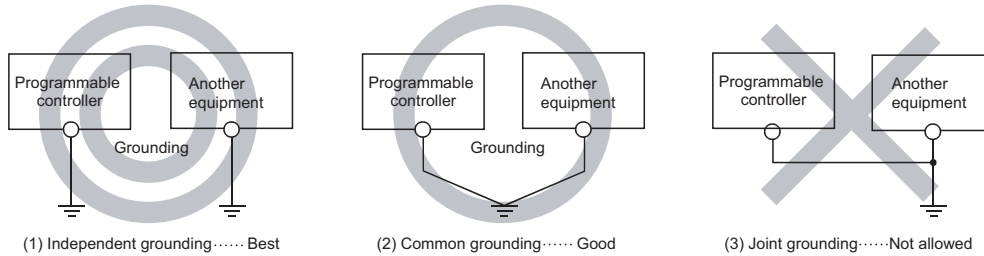

- Use thick cables up to 2mm<sup>2</sup>. Bring the grounding point close to the programmable controller as much as possible so that the ground cable can be shortened.

## 6.5.3 Precautions

---

This section describes wiring precautions.

### (1) Laying Ethernet cables

- Place the Ethernet cable in a duct or clamp them. If not, dangling cable may swing or inadvertently be pulled, resulting in damage to the module or cables or malfunction due to poor contact.
- Do not touch the core of the connector of the cable or the module, and protect it from dirt and dust. If any oil from your hand, or any dirt or dust sticks to the core, it can increase transmission loss, causing data link to fail.
- Check the following:
  - Is any Ethernet cable disconnected?
  - Does any Ethernet cable short?
  - Are the connectors securely connected?

### (2) Broken cable latch

Do not use Ethernet cables with broken latches. Doing so may cause the cable to unplug or malfunction.

### (3) Connecting and disconnecting the Ethernet cable

Hold the connector part when connecting and disconnecting the Ethernet cable. Pulling the cable connected to the module may result in damage to the module or cable or malfunction due to poor contact.

### (4) Connectors without Ethernet cable

To prevent dust from entering the module, attach the provided connector cover.

### (5) Maximum station-to-station distance (Maximum Ethernet cable length)

The maximum station-to-station distance is 100m. However, the distance may be shorter depending on the operating environment of the cable. For details, contact the manufacturer of the cables used.

### (6) Bending radius of the Ethernet cable

There are restrictions on the bending radius of the Ethernet cable. Check the bending radius in the specifications of the Ethernet cables used.

# CHAPTER 7 PARAMETER SETTING

This chapter describes parameter settings of a head module and modules connected to the head module. Open the setting screens by the following operation.

 Project window ⇨ [Parameter] ⇨ [PLC Parameter]

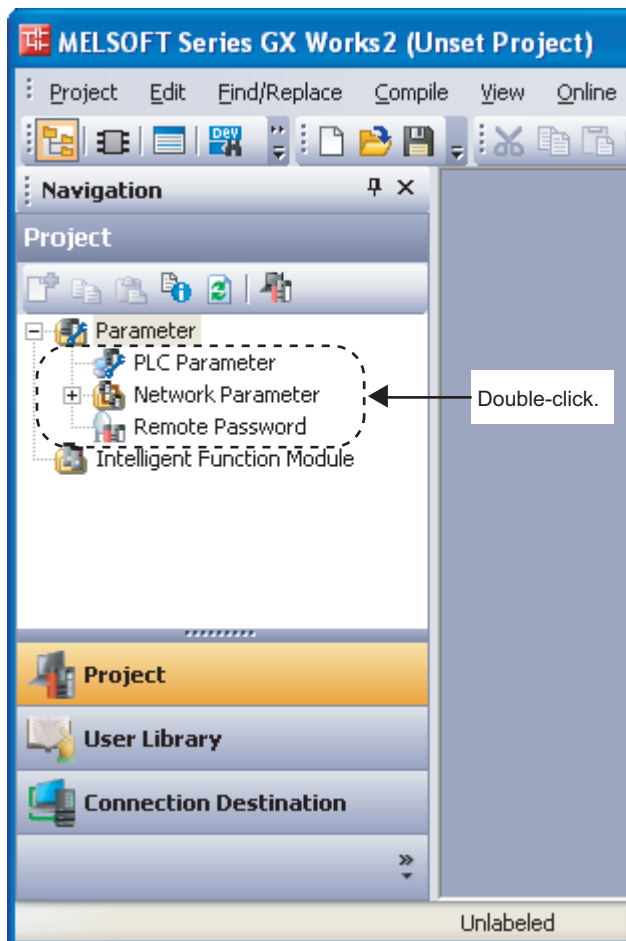

## Point

- Set parameters for the entire network (the number of slave stations, link device assignment, reserved station specification, and temporary error invalid station setting) to the master station. For details, refer to the following.  
 Relevant master/local module user's manual
- Routing parameters, used for communications with other networks, need not to be set to the head module. Communications with other networks are performed according to routing parameters set to the master station.

# 7.1 PLC Parameters

This section describes the setting screens and the descriptions of PLC parameters.

Setting screen	Description	Parameter No. *1	Reference
Communication Head Setting	Set parameters to connect the head module to a CC-Link IE Field Network.	01F0 <sub>H</sub>	Page 53, Section 7.1 (1)
PLC Name	Set the label and comment of the head module.	0000 <sub>H</sub> , 0001 <sub>H</sub>	Page 54, Section 7.1 (2)
PLC System	Set parameters for a system including the head module.	1002 <sub>H</sub>	Page 55, Section 7.1 (3)
PLC RAS	Set parameters for the RAS function.	300A <sub>H</sub>	Page 56, Section 7.1 (4)
Operation Setting	Set parameters to transfer data stored in the following head module devices as cyclic data. <ul style="list-style-type: none"> <li>• Link special relay (SB)</li> <li>• Link special register (SW)</li> <li>• Special relay (SM)</li> <li>• Special register (SD)</li> <li>• Link register (W)</li> </ul>	500F <sub>H</sub>	Page 57, Section 7.1 (5)
I/O Assignment	Set connection status of each module.	0400 <sub>H</sub> , 0403 <sub>H</sub> to 0405 <sub>H</sub> , 0409 <sub>H</sub>	Page 61, Section 7.1 (6)

\*1 Parameter numbers are used to identify a location where a parameter error has occurred.

## (1) Communication Head Setting

Set parameters to connect the head module to a CC-Link IE Field Network.

 Project window ⇨ [Parameter] ⇨ [PLC Parameter] ⇨ "Communication Head Setting"

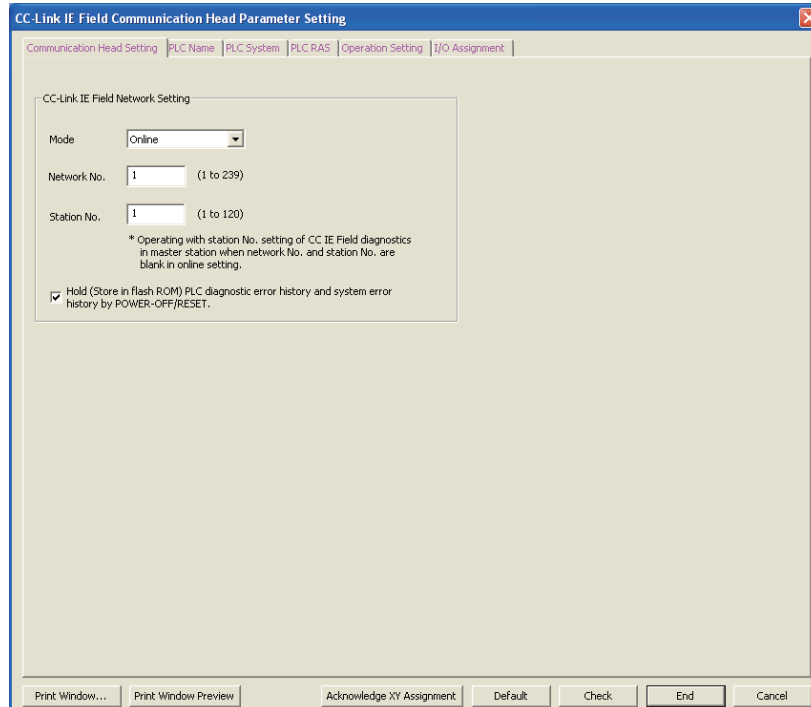

The following table shows setting items.

Item	Description	Setting range
Mode	Select a head module mode.	Online/Offline (Default: Online)
Network No.	Enter the network number of the head module.	• Blank* <sup>1</sup> • 1 to 239 • (Default: Blank)
Station No.	Enter the station number of the head module.	• Blank* <sup>1</sup> • 1 to 120 • (Default: Blank)
Hold (Store in flash ROM) PLC diagnostic error history and system error history by POWER-OFF/RESET.	Select whether to hold PLC diagnostic results and system error history data after the head module is powered off or is reset. Clearing the checkbox will delete data displayed in the "PLC diagnostics" dialog box and the "Error History" dialog box when the head module is powered off or is reset. (  Page 86, Section 11.2 (1) (a), Page 89, Section 11.3)	Selected/not selected (Default: Selected)

\*1 When the "Network No." and "Station No." fields are left blank in online mode, the head module with the station number set in CC-Link IE Field Network diagnostics for the master station will operate. For details, refer to "Procedure for Changing the Head Module". ( Page 32, Section 4.2)

## (2) PLC Name

Set the label and comment of the head module.

 Project window ⇨ [Parameter] ⇨ [PLC Parameter] ⇨ "PLC Name"

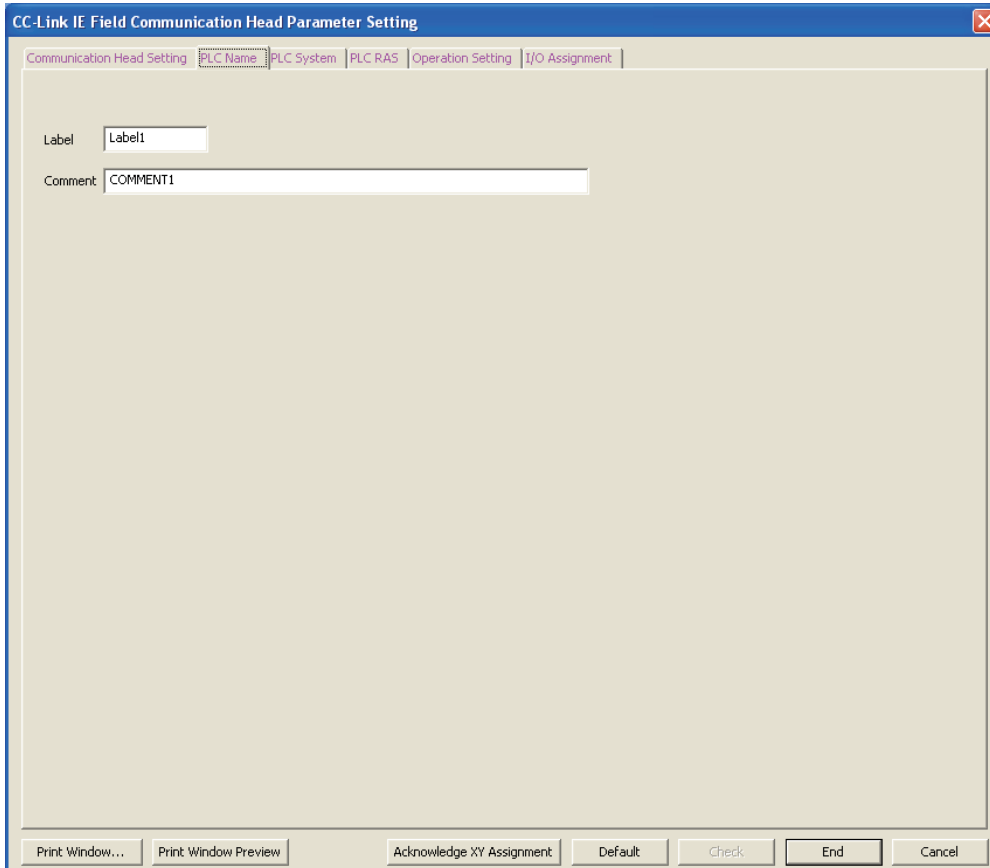

CC-Link IE Field Communication Head Parameter Setting

Communication Head Setting | **PLC Name** | PLC System | PLC RAS | Operation Setting | I/O Assignment

Label: Label1

Comment: COMMENT1

Print Window... | Print Window Preview | Acknowledge XY Assignment | Default | Check | End | Cancel

The following table shows setting items.

Item	Description	Setting range
Label	Enter the label (name or application) of the head module.	Up to 10 characters (Default: Blank)
Comment	Enter the comment of the head module.	Up to 64 characters (Default: Blank)



### (3) PLC System

Set parameters for a system including the head module.

 Project window ⇨ [Parameter] ⇨ [PLC Parameter] ⇨ "PLC System"

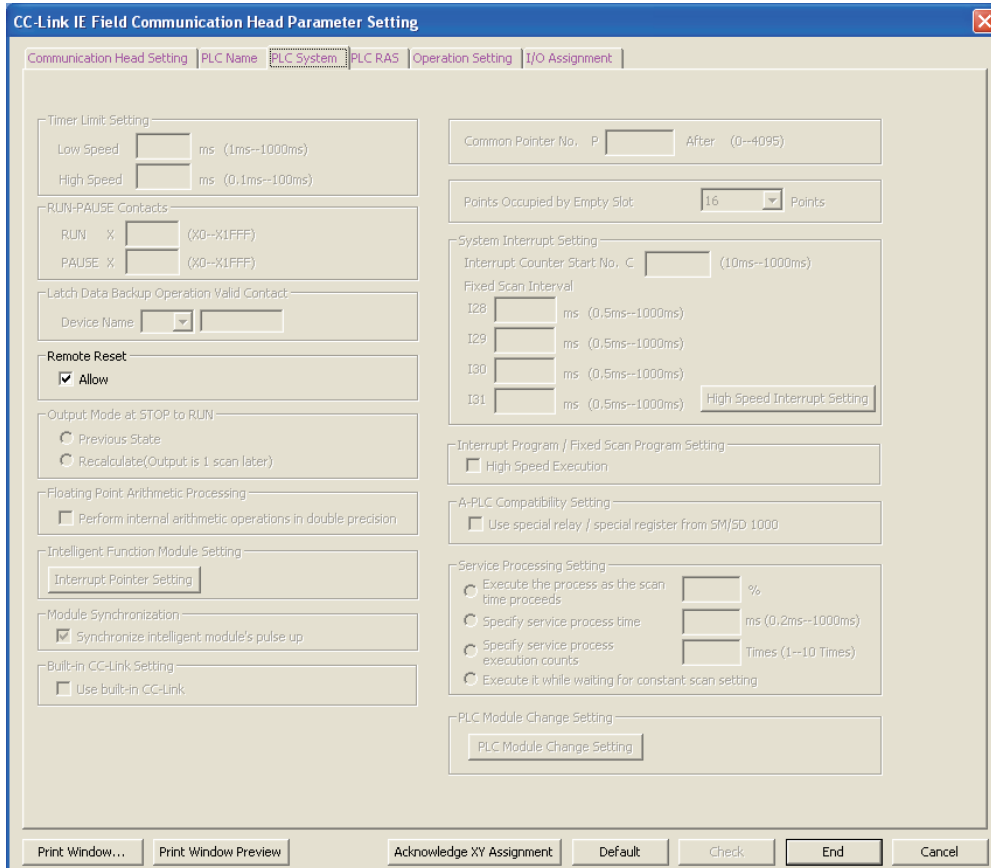

The following table shows a setting item.

Items other than "Remote Reset" cannot be set to the head module.

Item	Description	Setting range
Remote Reset	Allow	Select whether to allow GX Works2 to perform remote reset to the head module. Selected/not selected (Default: Selected* <sup>1</sup> )

\*1 The default differs from that of the CPU module. Note that when remote reset is performed to all stations.

## (4) PLC RAS

Set parameters for the RAS function.

 Project window ⇨ [Parameter] ⇨ [PLC Parameter] ⇨ "PLC RAS"

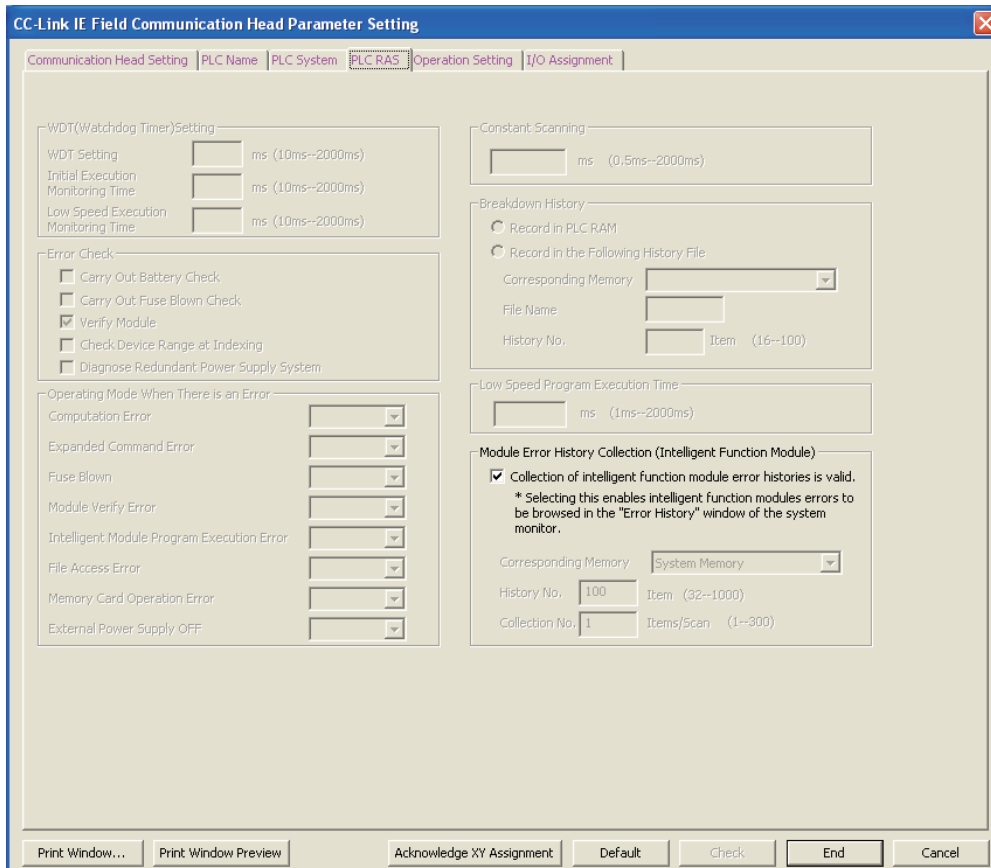

The following table shows a setting item.

Items other than "Module Error History Collection (Intelligent Function Module)" cannot be set to the head module.

Item		Description	Setting range
Module Error History Collection (Intelligent Function Module)	Collection of intelligent function module error histories is valid.	Select whether to collect errors occurred in an intelligent function module with the head module.	Selected/not selected (Default: Selected)

## (5) Operation Setting

Set parameters to transfer data stored in the following head module devices as cyclic data.

- Link special relay (SB)
- Link special register (SW)
- Special relay (SM)
- Special register (SD)
- Link register (W)

In Operation Setting, the following  part is configured.

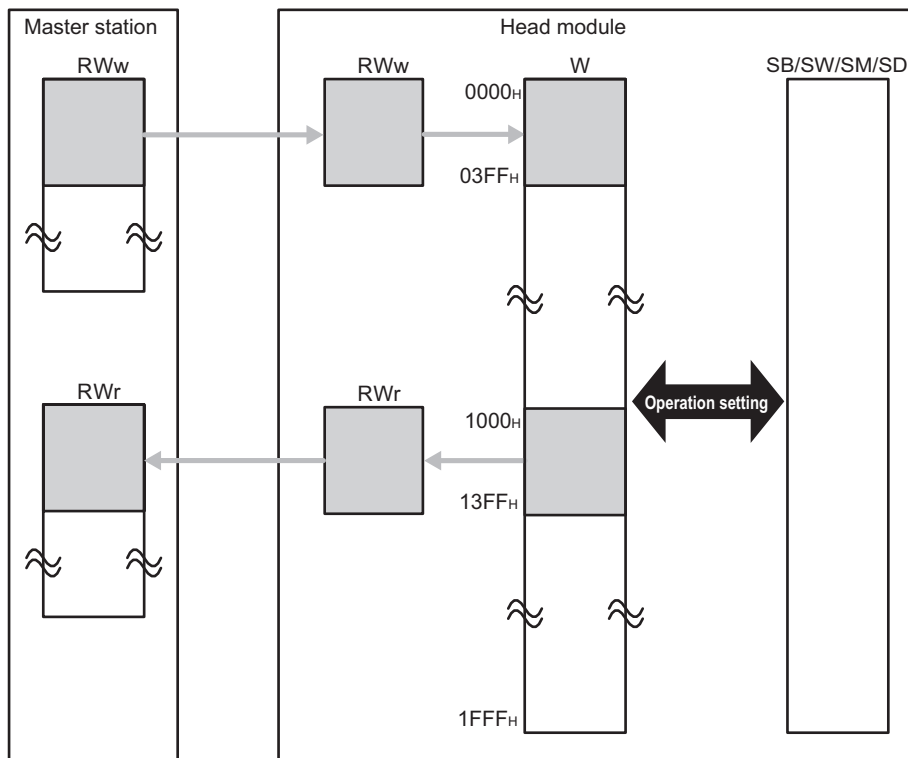

Project window ⇨ [Parameter] ⇨ [PLC Parameter] ⇨ "Operation Setting"

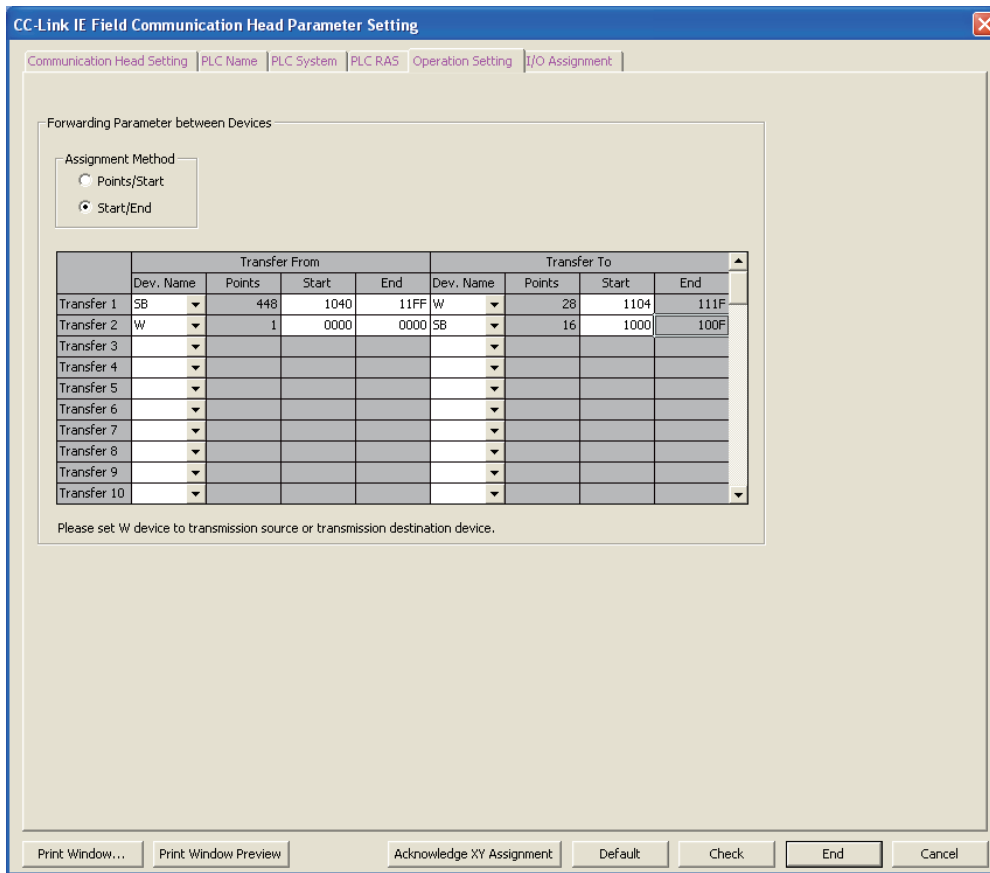

The following table shows setting items.

Item	Description	Setting range
Assignment Method	Select a link device assignment method. <ul style="list-style-type: none"> <li>Points/Start: Enter the points and start numbers of devices.</li> <li>Start/End: Enter the start and end device numbers.</li> </ul>	<ul style="list-style-type: none"> <li>Points/Start</li> <li>Start/End</li> </ul> (Default: Start/End)
Dev. Name	Select transfer source devices and transfer target devices. Select "W" for either of the devices.	<ul style="list-style-type: none"> <li>W</li> <li>SB</li> <li>SW</li> <li>SM</li> <li>SD</li> </ul> (Default: Blank)
Points	Enter the points of devices to be transferred.	<ul style="list-style-type: none"> <li>W: 1 to 4096</li> <li>SB: 16 to 8192</li> <li>SW: 1 to 8192</li> <li>SM: 16 to 2048</li> <li>SD: 1 to 2048</li> </ul> (Default: Blank)

Item	Description	Setting range
Start	Enter the start number of a device to be transferred.	Transfer From • W: 0 to 1FFF • SB: 0 to 1FF0 • SW: 0 to 1FFF • SM: 0 to 2032 • SD: 0 to 2047 (Default: Blank)  Transfer To • W: 1000 to 1FFF • SB: 0 to 1FF0 • SW: 0 to 1FFF • SM: 0 to 2032 • SD: 0 to 2047 (Default: Blank)
End	Enter the end number of a device to be transferred.	Transfer From • W: 0 to 1FFF • SB: F to 1FFF • SW: 0 to 1FFF • SM: 15 to 2047 • SD: 0 to 2047 (Default: Blank)  Transfer To This item is automatically set according to the setting of transfer source.

**(a) Setting example**

To transfer the link special relay (SB) data of the head module as cyclic data, transfer the link special relay (SB) value to link register (W).

Setting for Forwarding Parameter between Devices

	Transfer From				Transfer To			
	Dev. Name	Points	Start	End	Dev. Name	Points	Start	End
Transfer 1	SB	448	1040	11FF	W	28	1104	111F
Transfer 2	W	1	0000	0000	SB	16	1000	100F

Transfer 1: Transfers the values in SB1040 to SB11FF to W1104 to W111F.

Transfer 2: Transfers the value in W0000 to SB1000 to SB100F.

Operation of the head module

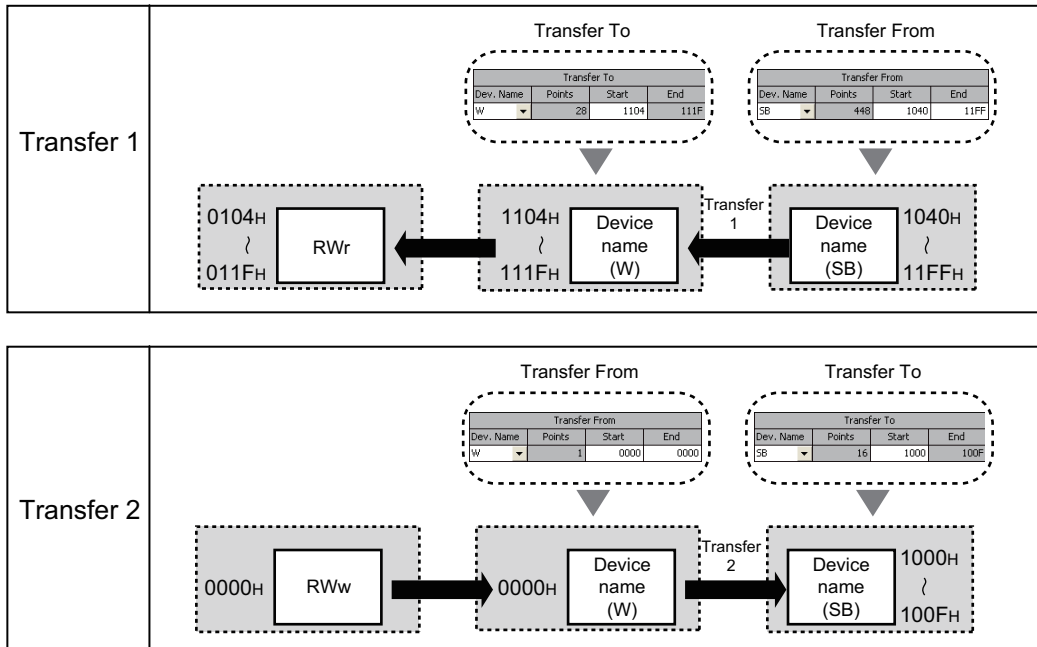

## (6) I/O Assignment

Set connection status of each module.

 Project window ⇨ [Parameter] ⇨ [PLC Parameter] ⇨ "I/O Assignment"

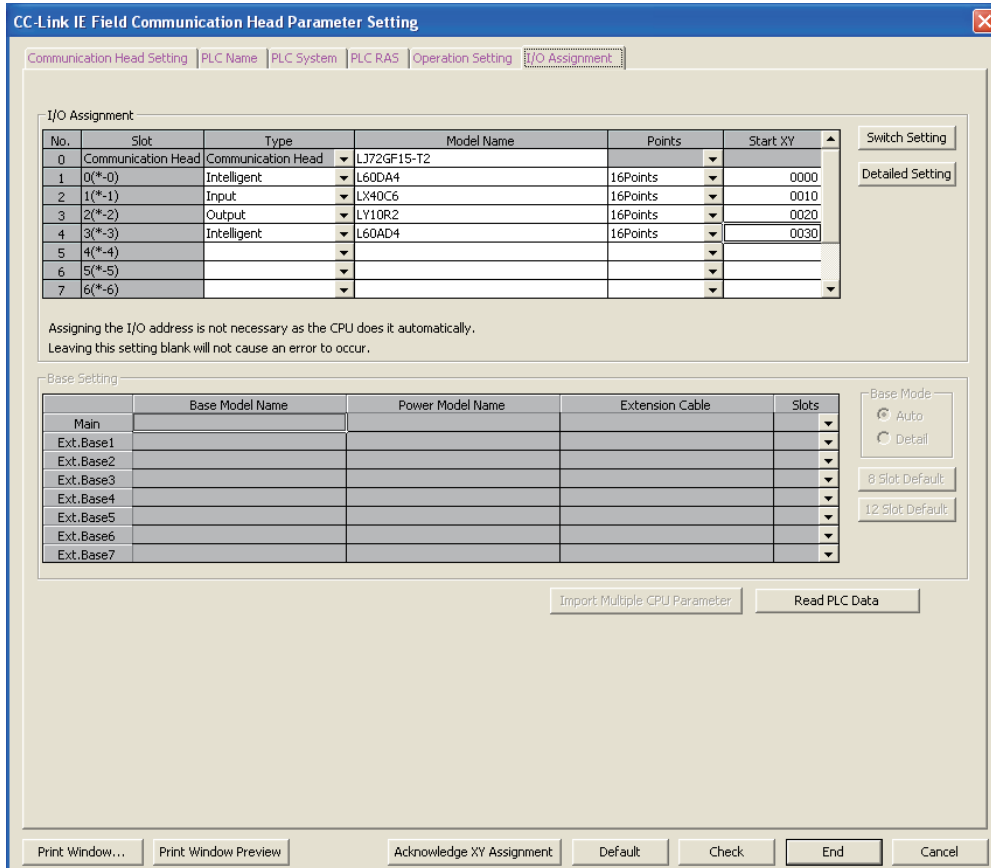

The screenshot shows the 'I/O Assignment' tab of the 'CC-Link IE Field Communication Head Parameter Setting' dialog. It features a table for assigning modules to slots, with columns for No., Slot, Type, Model Name, Points, and Start XY. Below the table is a 'Base Setting' section with a table for Base Model Name, Power Model Name, Extension Cable, and Slots. The dialog also includes buttons for 'Switch Setting', 'Detailed Setting', 'Import Multiple CPU Parameter', 'Read PLC Data', and 'Acknowledge XY Assignment'.

No.	Slot	Type	Model Name	Points	Start XY
0	Communication Head	Communication Head	LJ72GF15-T2		
1	0(*-0)	Intelligent	L60DA4	16Points	0000
2	1(*-1)	Input	LX40C6	16Points	0010
3	2(*-2)	Output	LY10R2	16Points	0020
4	3(*-3)	Intelligent	L60AD4	16Points	0030
5	4(*-4)				
6	5(*-5)				
7	6(*-6)				

	Base Model Name	Power Model Name	Extension Cable	Slots
Main				
Ext. Base1				
Ext. Base2				
Ext. Base3				
Ext. Base4				
Ext. Base5				
Ext. Base6				
Ext. Base7				

The following table shows setting items.

Item		Description	Setting range
I/O Assignment	Type	Select a connected module type.	Empty, Input, Output, Intelligent (Default: Blank)
	Model Name	Enter the model name of the connected module when required.	Up to 16 characters (Default: Blank)
	Points	Select the occupied I/O points of a module connected to the head module.	0 Point, 16 Points, 32 Points, 64 Points, 128 Points (Default: Blank)
	Start XY	Enter the start I/O number.	0000H to 0FE0H (Default: Blank)
Switch Setting button		Set intelligent function module switches.	-
Detailed Setting button	Error Time Output Mode	Select output mode in the following status: • An error occurred in the head module. • A data link error occurred.	Clear/Hold (Default: Clear)
	PLC Operation Mode at H/W Error	If a hardware error occurs in an intelligent function module (The head module detects SP.UNIT DOWN.), select whether to stop auto refresh of the head module.	Stop/Continue (Default: Stop)
	I/O Response Time	Select the response time of an input module.	1ms, 5ms, 10ms, 20ms, 70ms (Default: 10ms)

## 7.2 Network Parameters

Set parameters of the CC-Link master/local module connected to the head module.

 Project window ⇨ [Parameter] ⇨ [Network Parameter] ⇨ [CC-Link]

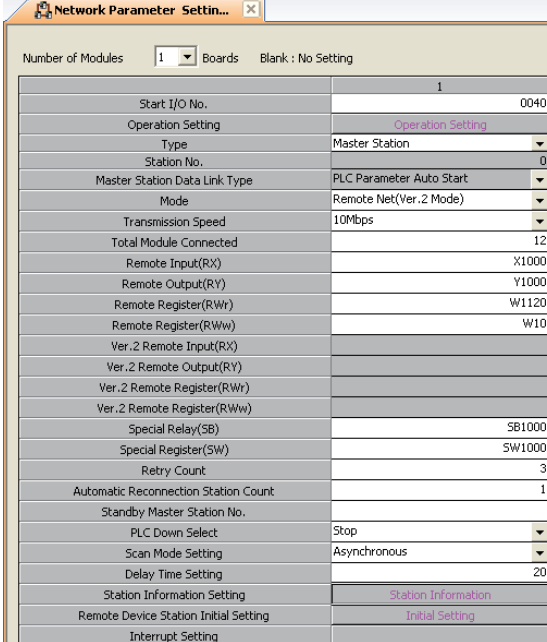

Number of Modules: 1 Boards Blank : No Setting	
Start I/O No.	1 0040
Operation Setting	Operation Setting
Type	Master Station
Station No.	0
Master Station Data Link Type	PLC Parameter Auto Start
Mode	Remote Net(Ver.2 Mode)
Transmission Speed	10Mbps
Total Module Connected	12
Remote Input(RX)	X1000
Remote Output(RY)	Y1000
Remote Register(RWr)	W1120
Remote Register(RWw)	W10
Ver.2 Remote Input(RX)	
Ver.2 Remote Output(RY)	
Ver.2 Remote Register(RWr)	
Ver.2 Remote Register(RWw)	
Special Relay(SB)	SB1000
Special Register(SW)	SW1000
Retry Count	3
Automatic Reconnection Station Count	1
Standby Master Station No.	
PLC Down Select	Stop
Scan Mode Setting	Asynchronous
Delay Time Setting	20
Station Information Setting	Station Information
Remote Device Station Initial Setting	Initial Setting
Interrupt Setting	

For network parameters (CC-Link), refer to the following.

 MELSEC-L CC-Link System Master/Local Module User's Manual

### Point

Configure a CC-Link system so that the points of devices used for CC-Link communications (RX/RX/RWr/RWw) may be within the maximum link points per station. (👉 Page 27, Section 3.2)  
If the CC-Link points exceeds the maximum link points per station in a large-scale system, for example, a system containing 64 stations, use W as a refresh device, instead of X and Y. (👉 Page 71, Section 8.2)



## 7.3 Remote Password

Set a remote password to a serial communication module.

 Project window ⇨ [Parameter] ⇨ [Remote Password]

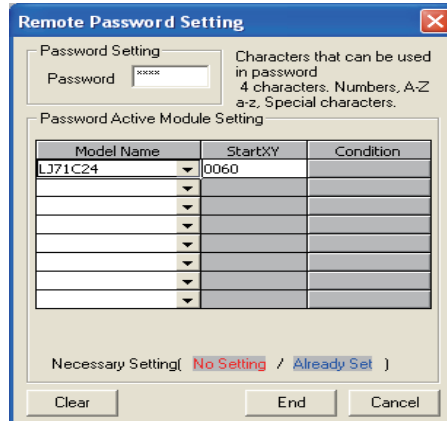

The following table shows setting items.

Item		Description	Setting range
Password Setting		Enter a remote password.	Up to four characters (alphanumeric characters, special symbols) (Default: Blank)
Password Active Module Setting	Model Name	Select the model name of the target serial communication module.	LJ71C24 (Default: Blank)
	Start XY	Enter the start I/O number of the target serial communication module.	0000H to 0FE0H



For details on a remote password, refer to the following.



 MELSEC-Q/L Serial Communication Module User's Manual (Application)

# 7.4 Intelligent Function Module Parameters

Set intelligent function module parameters.  
 Set the parameters in the "New Module" dialog box.

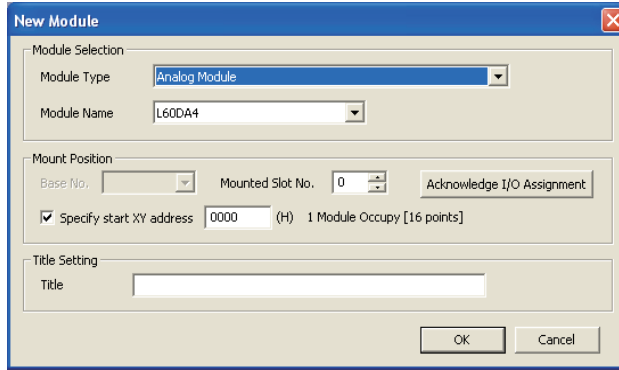
 Project window ⇨ Right-click [Intelligent Function Module] ⇨ [New Module]



Item		Description	Setting range
Module Selection	Module Type	Select a module type.	 Relevant intelligent function module manual
	Module Name	Select a model name.	
Mount Position	Mounted Slot No.	Select the number of the slot where an intelligent function module is mounted.	
	 Acknowledge I/O Assignment button	Click this button to check I/O assignment setting configured in the PLC Parameter dialog box.	
	Specify start XY address	Set the start I/O number.	
Title Setting	Title	Enter a title displayed in the Project window.	

After these settings are configured, a folder is created under the "Intelligent Function Module" folder in the Project window.

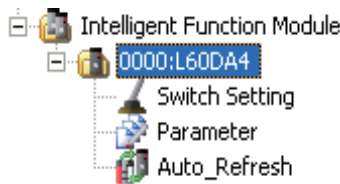

# CHAPTER 8 CYCLIC TRANSMISSION

This chapter describes how to perform cyclic transmission of bit and word device data of the head module.

## 8.1 Cyclic Transmission of Bit Device Data

The inputs (X) and outputs (Y) of the modules connected to the head module can be handled just like those of the master station.

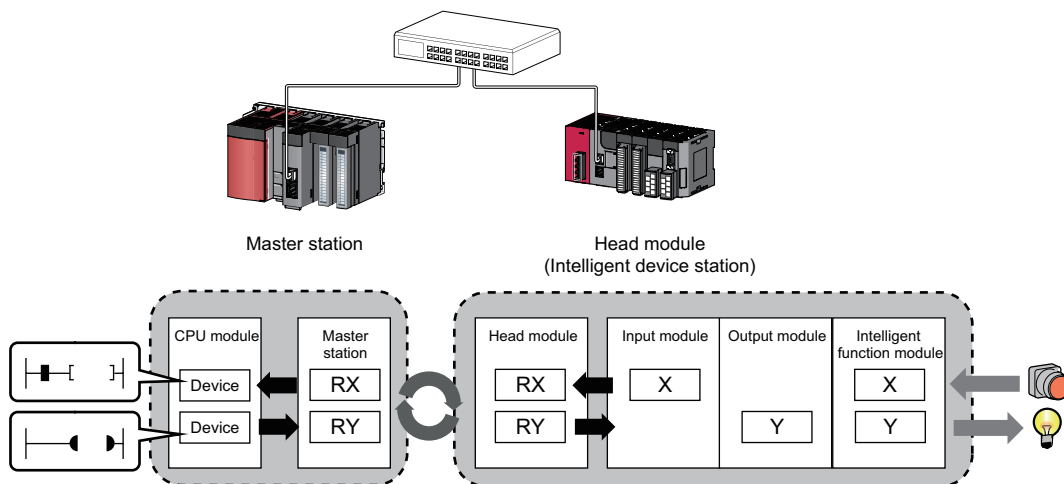

## (1) Data flow

This section describes the data flow and the setting for cyclic transmission of bit device data.

- When inputting from an intelligent device station to the master station  
The input data (X) of each module connected to the head module is input to the remote input (RX) of the master station.
- When outputting from the master station to the intelligent device station  
The remote output data (RY) of the master station is output to the output (Y) of each module connected to the head module.

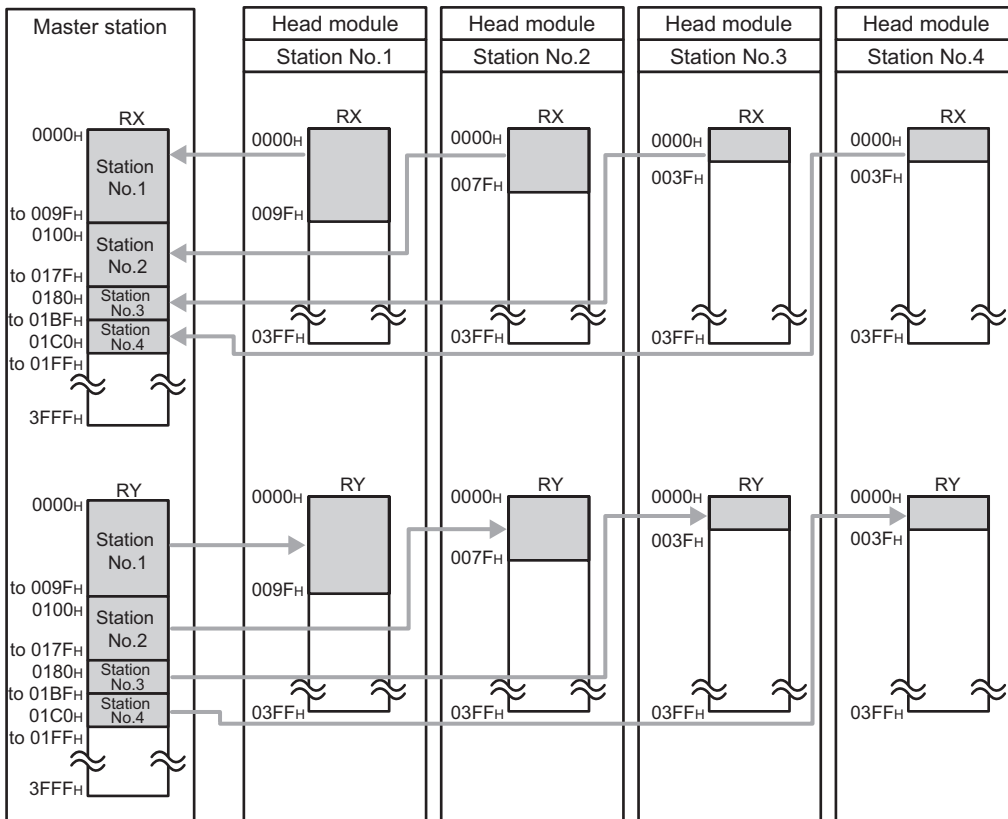

The I/O data flow between the master station and the head module on the station number 1 are shown in Page 67, Section 8.1 (1) (a), Page 68, Section 8.1 (1) (b).

(a) Setting "0000H" for the start number of RX/RY setting for the master station and leaving the I/O assignment setting for the head module default

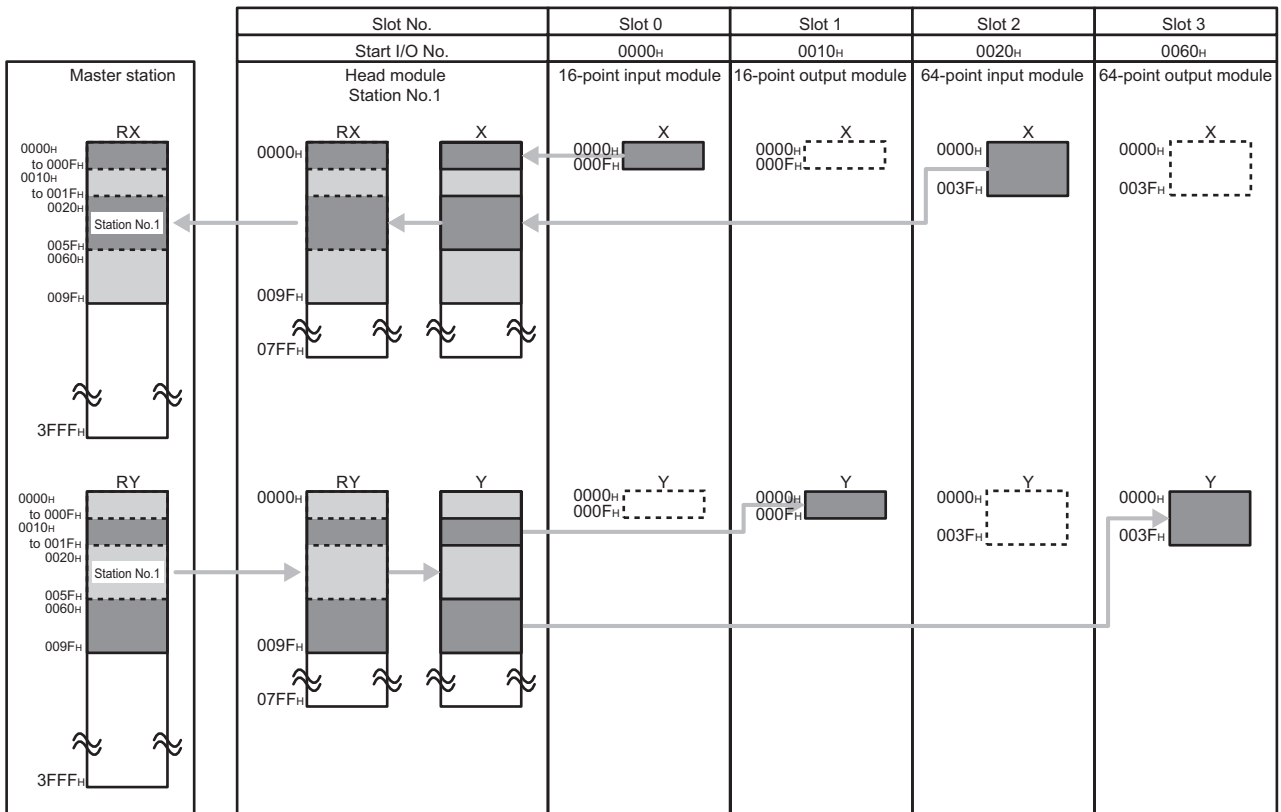

**(b) Setting "0000H" for the start number of RX/RY setting for the master station and changing the I/O assignment setting for the head module**

The figure on the bottom shows assignment when I/O assignment is set as the figure below.

I/O Assignment

No.	Slot	Type	Model Name	Points	Start XY
0	Communication Head	Communication Head			
1	0(*-0)	Input	LX40C6	16Points	0020
2	1(*-1)	Output	LY10R2	16Points	0000
3	2(*-2)	Input	LX40C6	16Points	0030
4	3(*-3)	Output	LY10R2	16Points	0010
5	4(*-4)				
6	5(*-5)				
7	6(*-6)				

Switch Setting  
Detailed Setting

Assigning the I/O address is not necessary as the CPU does it automatically.  
Leaving this setting blank will not cause an error to occur.

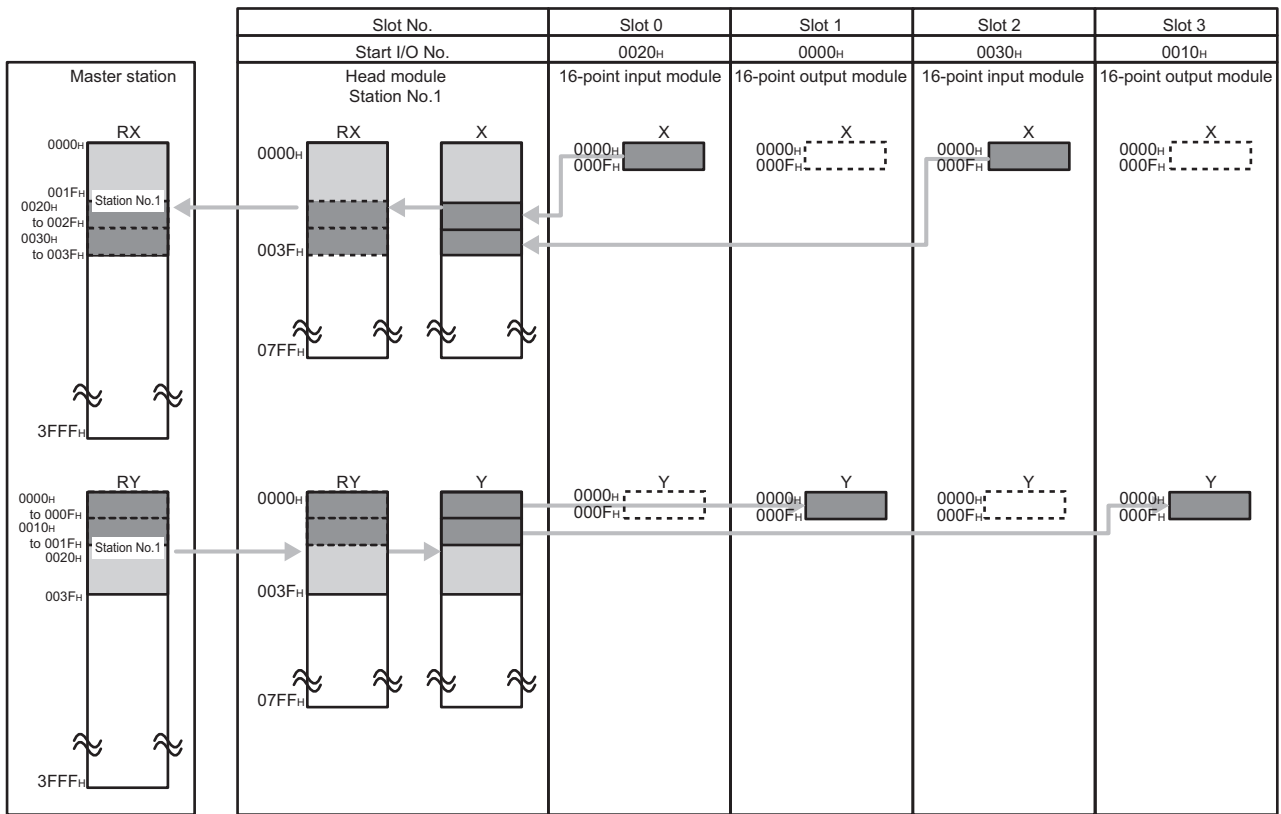

## (2) Setting method

In Network Configuration Setting of the master station, set the total number of points for the input/output (X/Y) of the modules connected to the head module, in 16-point units.

In the case of the diagram on the previous page, specify "0000" to "003F" for "RX/RX Setting".

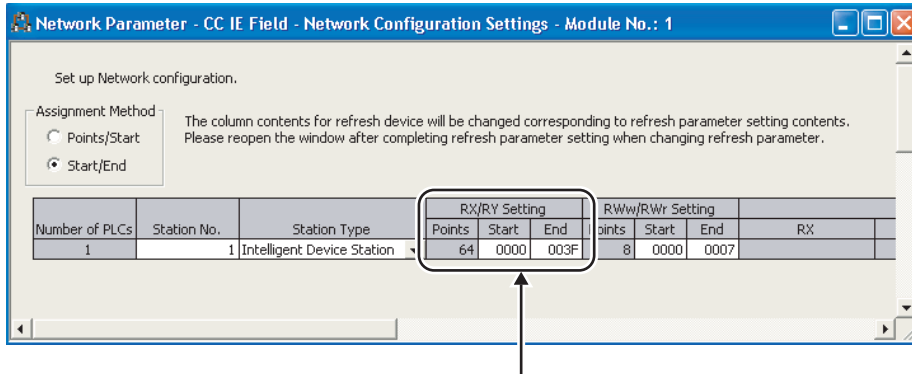

### Point

- To set an empty slot in the intelligent device station or to change a start I/O number, modify the data in the I/O Assignment setting of the head module.

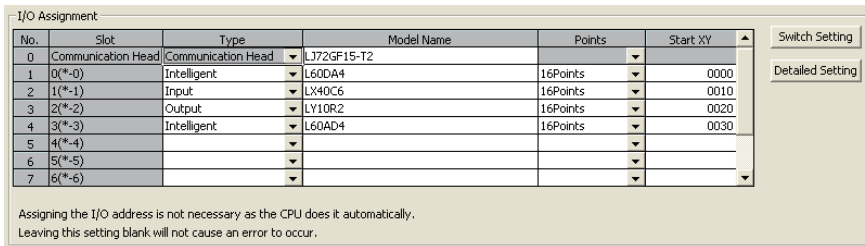









- If the number of points will be increased for a system expansion in future, for example, set a large number for "RX/RX Setting" in Network Configuration Setting of the master station. Doing so will eliminate the need to change parameters for the master station at the time of the system expansion. However, increasing the number of points also increases the processing time.

### (3) Output status for each status

Depending on the states of the data link and head module, data may not be able to be output.

The following table shows how the states of the data link and head module affect the output (Y).

-: Not dependent on the status

Switch	Head Module Status	Data Link Status	Output (Y) Status
RUN	Operating normally	Cyclic transmission in progress	<p>Varies depending on the status and setting of the master station. (  User's manual for the master/local module used)</p> <p>(1) If the CPU module of the master station is in the stop error status: The output (Y) status is determined by the "Error Time Output Mode" setting in the PLC Parameter dialog box. (  Page 61, Section 7.1 (6)) The analog output status from the digital-analog converter module is determined by the setting of the analog output HOLD/CLEAR function. (  MELSEC-L Digital-Analog Converter Module User's Manual)</p> <p>(2) When the CPU module on the master station is in the STOP status: The output (Y) is determined by the refresh parameters (refresh device of RY for the head module) of the master station. • If "Y" is specified for the CPU side device, the output (Y) of the head module turns off. • If "other than Y (M, L, etc.)" is specified for the CPU side device, the output (Y) of the head module depends on "Case of CPU STOP Setting" of the master station. The analog output status from the digital-analog converter module is determined by the setting of the analog output HOLD/CLEAR function. (  MELSEC-L Digital-Analog Converter Module User's Manual)</p>
RUN	Operating normally	Cyclic transmission stopped	<p>The output (Y) status is determined by the "Error Time Output Mode" setting in the PLC Parameter dialog box. (  Page 61, Section 7.1 (6)) The analog output status from the digital-analog converter module is determined by the setting of the analog output HOLD/CLEAR function. (  MELSEC-L Digital-Analog Converter Module User's Manual)</p>
RUN	Operating normally	Disconnected	<p>The output (Y) is held for 2 seconds after the module cannot be communicated with the master station due to a cause such as disconnection of the Ethernet cable. The output (Y) status after disconnection is determined by the "Error Time Output Mode" setting in the PLC Parameter dialog box. (  Page 61, Section 7.1 (6))</p>
-	Error	-	<p>The output (Y) status is determined by the "Error Time Output Mode" setting in the PLC Parameter dialog box. (  Page 61, Section 7.1 (6))</p>
STOP	Operating normally	-	<p>The analog output status from the digital-analog converter module is determined by the setting of the analog output HOLD/CLEAR function. (  MELSEC-L Digital-Analog Converter Module User's Manual) The output (Y) turns off.</p>



## 8.2 Cyclic Transmission of Word Device Data

Word data, such as a buffer memory of the module connected to the head module, can be used in the word device of the master station.

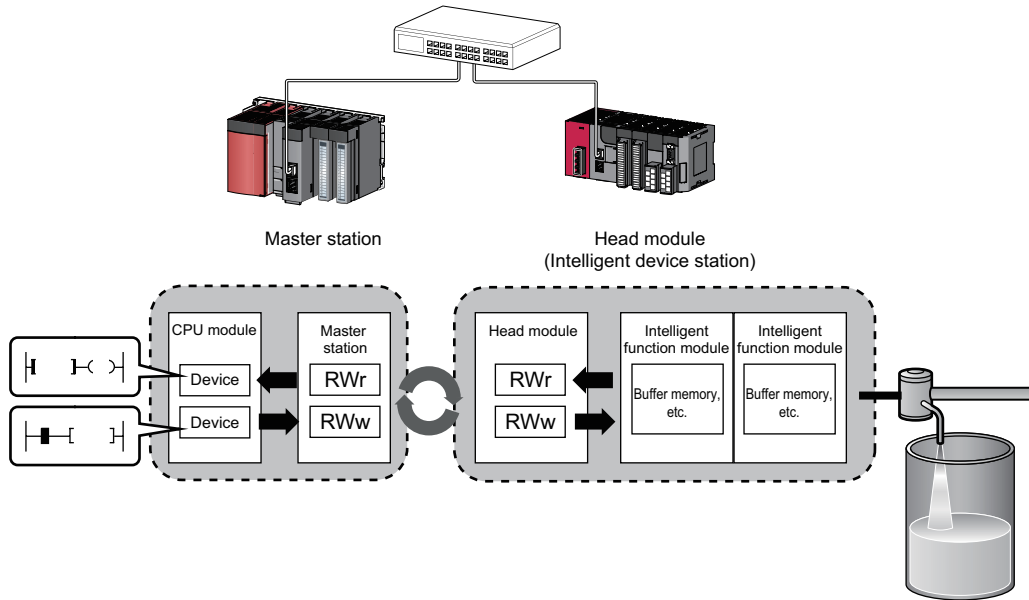

## (1) Data flow

This section describes the data flow and the setting for cyclic transmission of word device data.

- When transferring data from the master station to the intelligent device station  
The remote register (RWw) data of the master station is transferred to the buffer memory of the intelligent function module connected to the head module.
- When transferring data from the intelligent device station to the master station  
The buffer memory data of the intelligent function module connected to the head module is transferred to the remote register (RWr) of the master station.

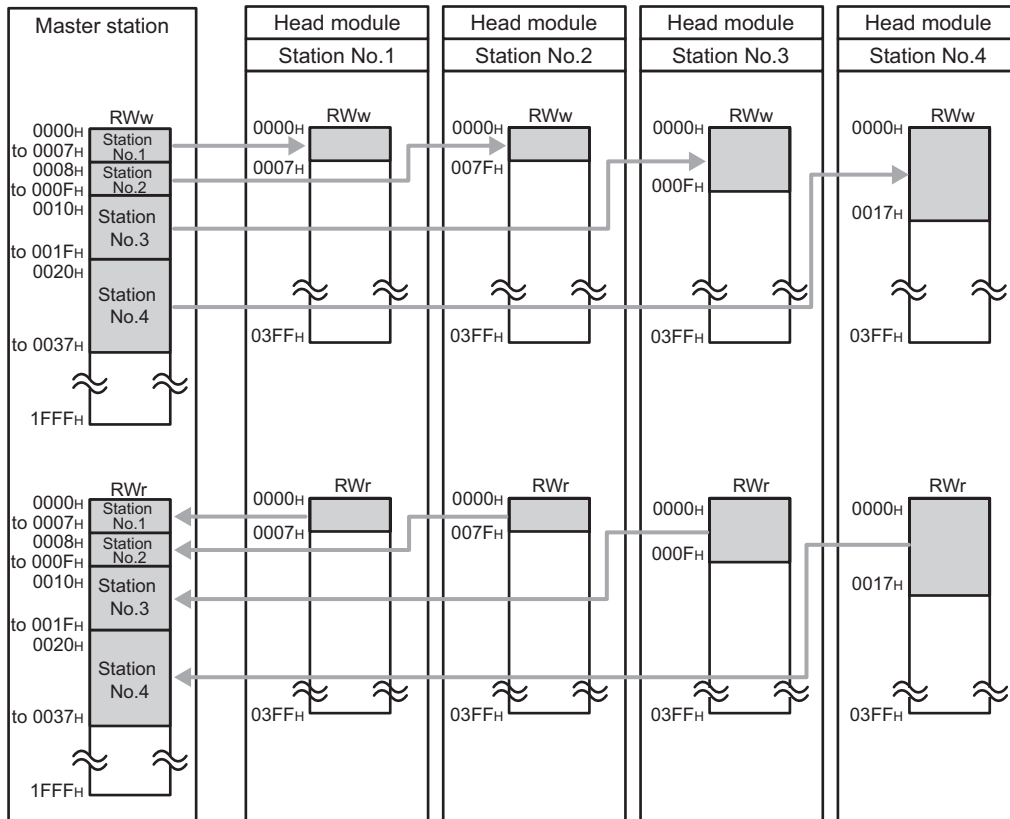

The data transfer flow between the master station and the head module on the station number 1 are shown in Page 73, Section 8.2 (1) (a).

## (a) Setting "0000H" for the start number of RWw/RWr setting for the master station

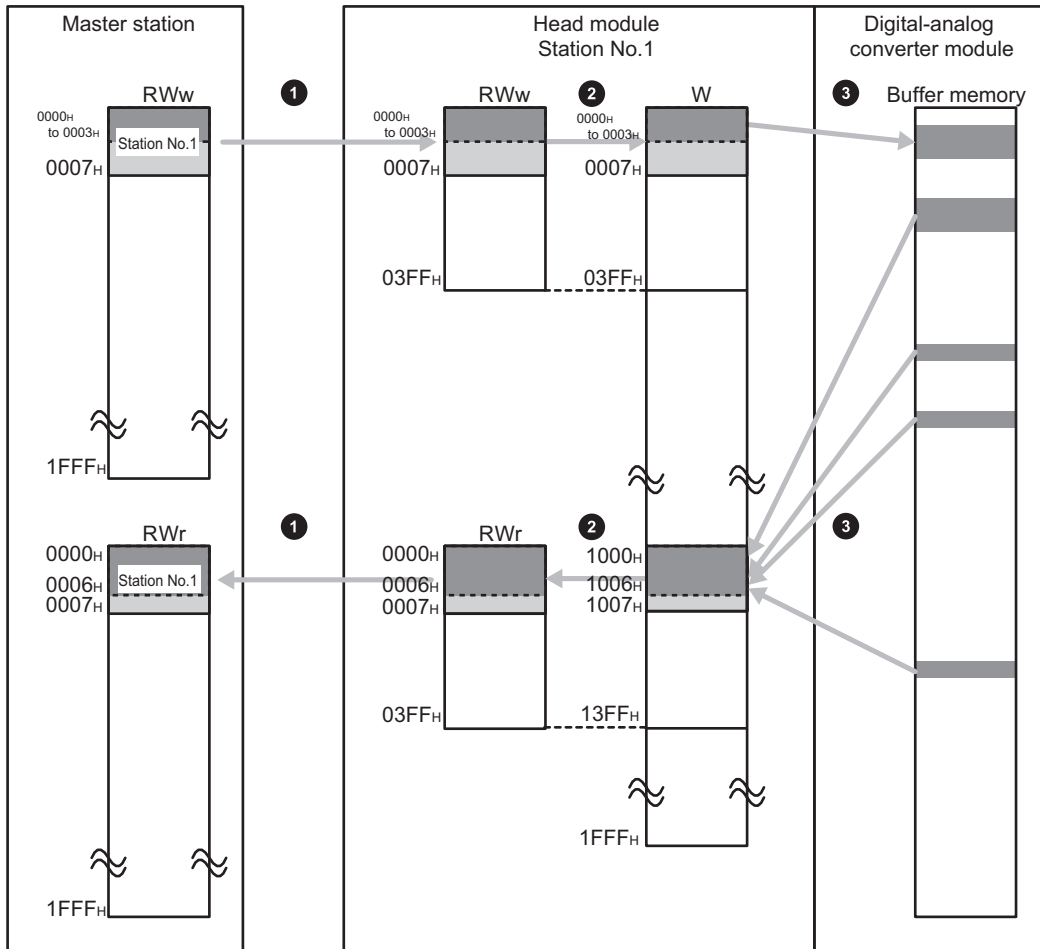

- ① Set RWw/RWr ranges assigned to the head module in "Network Configuration Setting" of the master station. (☞ Page 74, Section 8.2 (2), procedure 2)
- ② Assign 1024 points of W0 to W3FF from RWw0.  
Assign 1024 points of W1000 to W13FF from RWr0.
- ③ Set the refresh ranges of buffer memories in the head module and the intelligent function module using auto refresh setting. (☞ Page 74, Section 8.2 (2), procedure 1)

## (2) Setting method

1. Set the auto refresh of the intelligent function module connected to the head module.

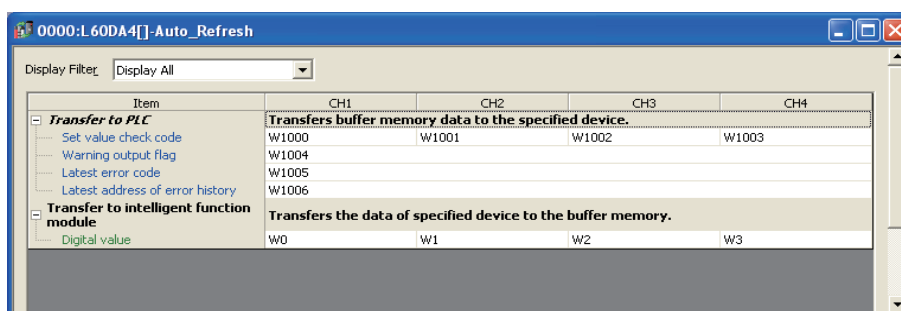

Specify the following devices as the devices to be auto refreshed.

Item	Setting range of auto refresh target device
"Transfer to PLC"	W1000 to W13FF
"Transfer to intelligent function module"	W0 to W3FF

2. In the Network Configuration Setting of the master station, set the number of points for RWw/RWr to be assigned to the head module.

The number of points should be higher than the number of points set in the auto refresh setting, in the step 1 above. (Set the number of points whichever is greater between "Transfer to CPU" and "Transfer to intelligent function module".)

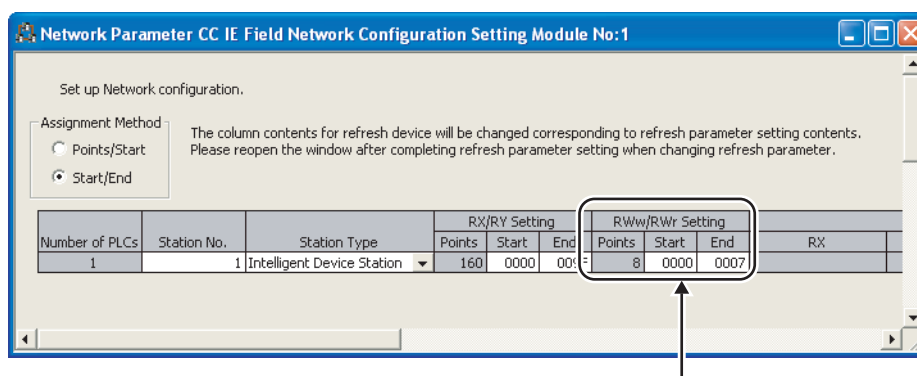

### Point

If the number of points will be increased for a system expansion in future, for example, set a large number for "RWw/RWr Setting" in Network Configuration Setting of the master station. Doing so will eliminate the need to change parameters for the master station at the time of the system expansion. However, increasing the number of points also increases the processing time.

# CHAPTER 9 CC-Link IE FIELD NETWORK DIAGNOSTICS

This section describes how to check error locations and error causes by the CC-Link IE Field Network diagnostics of GX Works2.

how to check error locations and error causes by the CC-Link IE Field Network diagnostics of GX Works2.

When GX Works2 is connected to the master station, the entire network status can be monitored. If an intelligent device station cannot be monitored due to cable disconnection or any other error, directly connect GX Works2 to the head module.

This chapter describes a method for diagnosing the head module by directly connecting GX Works2. When GX Works2 is connected to the master station, refer to the following.

Relevant master/local module user's manual

## 9.1 Diagnostic Items

The following shows items that can be diagnosed by CC-Link IE Field Network diagnostics (when GX Works2 is connected to the head module).

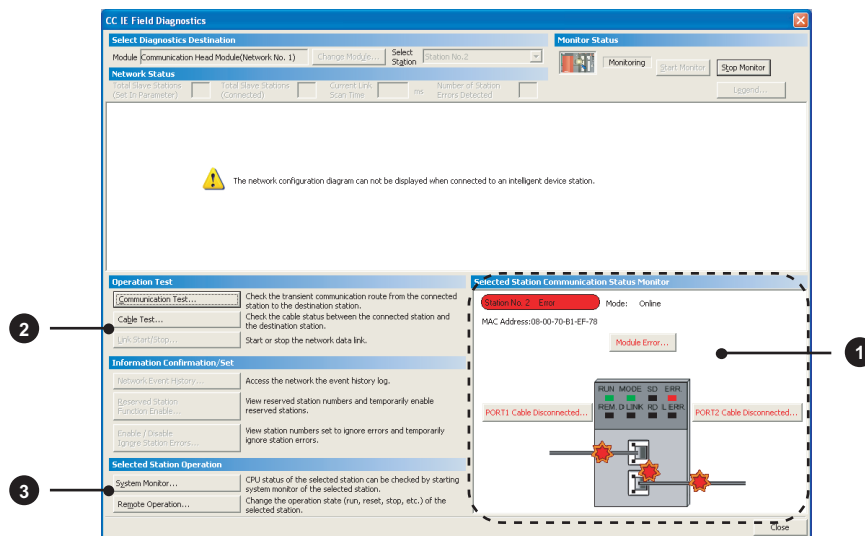

9.1 Diagnostic Items

	Item	Reference
1	Display of head module status and error details	Page 78, Section 9.3
2	Communication Test	Page 80, Section 9.4
	Cable Test	Page 80, Section 9.5
3	System Monitor	Page 81, Section 9.6
	Remote Operation	Page 81, Section 9.7

## 9.2 Starting Diagnostics

This section describes how to use CC-Link IE Field Network diagnostics.

1. Connect GX Works2 to the head module.
2. Start CC-Link IE Field Network diagnostics from the menu.

 [Diagnostics] ⇨ [CC IE Field Diagnostics]

### Point

- When another station has been specified as a connected station  
CC-Link IE Field Network diagnostics cannot be started when another station has been specified in "Other Station Setting" of the "Transfer Setup" dialog box. In this case, directly connect GX Works2 to the head module.
- Start from the "PLC Diagnostics" dialog box  
CC-Link IE Field Network diagnostics can also be started from the "PLC Diagnostics" dialog box.

1. With the mouse, select the connector to which the Ethernet cable is connected.

2. Click "CC-Link IE Field Diagnostics" appearing on the right side.

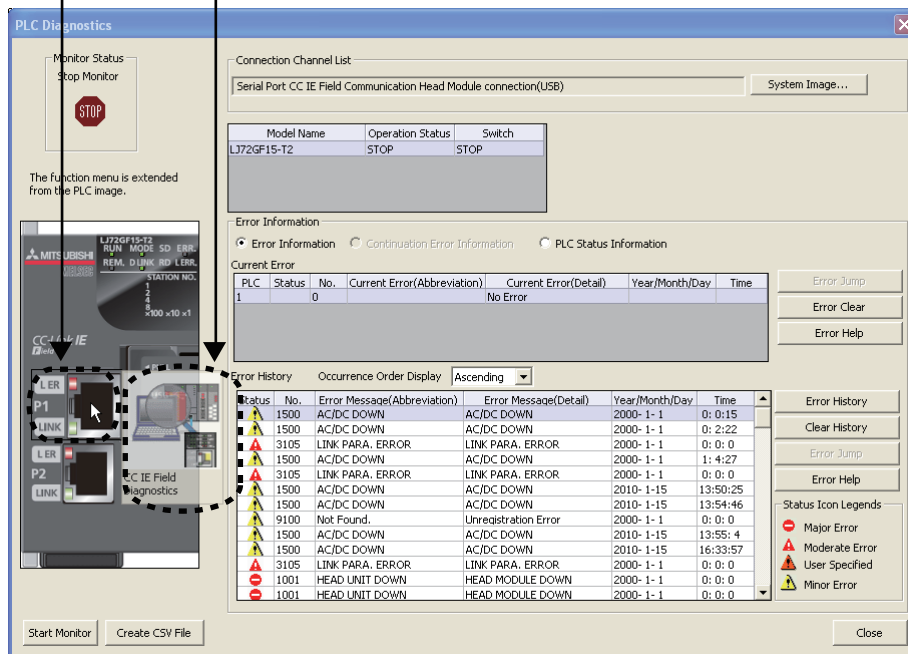

**3. The head module status is displayed in "Selected Station Communication Status Monitor".**

(👉 Page 78, Section 9.3)

If an error occurs, a button indicating the error (e.g. **PORT2 Cable Disconnected...** button) is displayed. Clicking the button allows checking of error details and corrective actions.

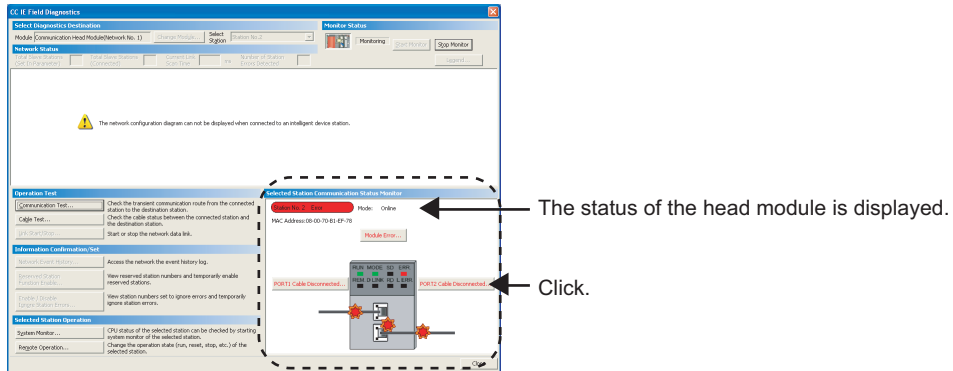

**4. Various tests and operations can be performed from "Operation Test" and "Selected Station Operation" on the bottom left of the dialog box. (👉 Page 80, Section 9.4 to Page 81, Section 9.7)**

Various tests and operations can be performed.

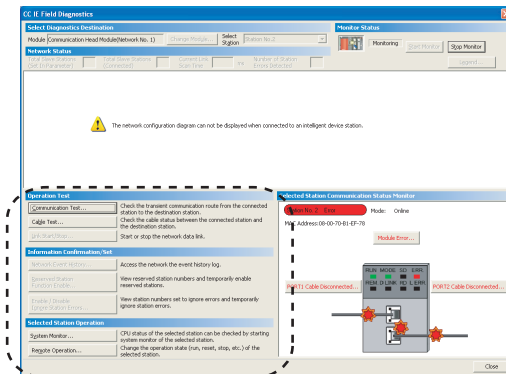



## 9.3 Diagnostic Screen



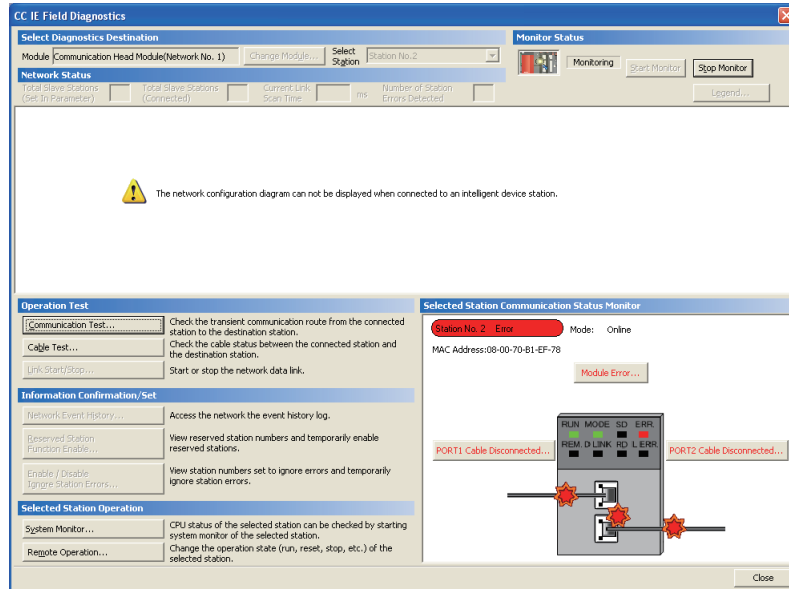

This section describes items displayed in the "CC IE Field Diagnostics" dialog box.

### (1) Displayed items

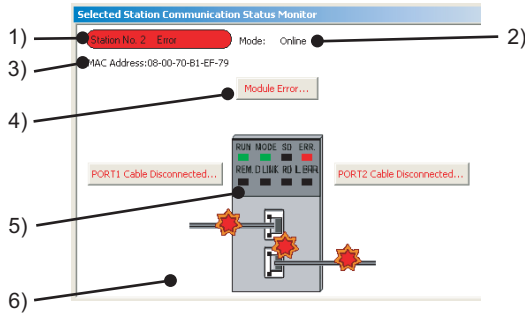

Item		Description
Monitor Status	 button	Starts monitoring of CC-Link IE Field Network diagnostics.
	 button	Stops monitoring of CC-Link IE Field Network diagnostics.



Item	Description	
Selected Station Communication Status Monitor	<p>Displays head module status.</p> 	
	1)	<p>Displays operating status.</p> <ul style="list-style-type: none"> <li>Station No. 1 No Error : Normal</li> <li>Station No. 1 Error : Error (Data link is continued.) (yellow)</li> <li>Station No. 1 Error : Error (Data link is stopped.) (red)</li> </ul>
	2)	Displays a mode.
	3)	Displays a MAC address.
	4)	Click this button to check error details. Take corrective actions, following description displayed in "Error Factor" and "Troubleshooting".
	5)	Displays the LED status of the head module and communication status of PORT1 and PORT2. (Page 22, CHAPTER 2)
6)	<p>Displays status of the cables connected to PORT1 and PORT2.</p> <ul style="list-style-type: none"> <li> : Normal</li> <li> : Error (cable disconnection)</li> <li> : Error (other than cable disconnection)</li> </ul>	
Operation Test	<p>Communication Test... button</p>	Performs a communication test. ( Relevant master/local module user's manual)
	<p>Cable Test... button</p>	Performs a cable test. ( Relevant master/local module user's manual)
Selected Station Operation	<p>System Monitor... button</p>	Displays the System Monitor dialog box. (Page 89, Section 11.3)
	<p>Remote Operation... button</p>	Performs remote operation (RUN, STOP, and RESET operations) to the head module. (Page 81, Section 9.7)

## 9.4 Communication Test

Communication test checks if transient transmission data is properly routed from the own station to the communication target. For test method, refer to the following.

 Relevant master/local module user's manual

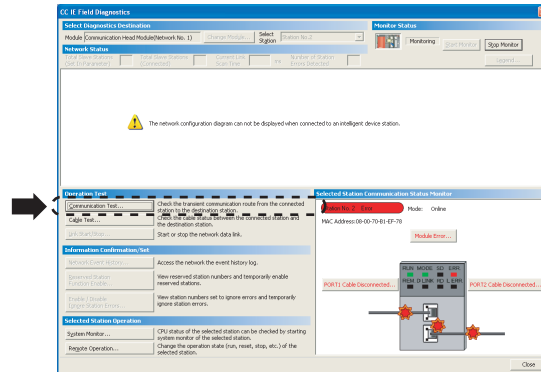

## 9.5 Cable Test

Cable test checks if an Ethernet cable is properly connected. Only an Ethernet cable connected to the PORT1 or PORT2 of the target station is tested. For test method, refer to the following.

 Relevant master/local module user's manual

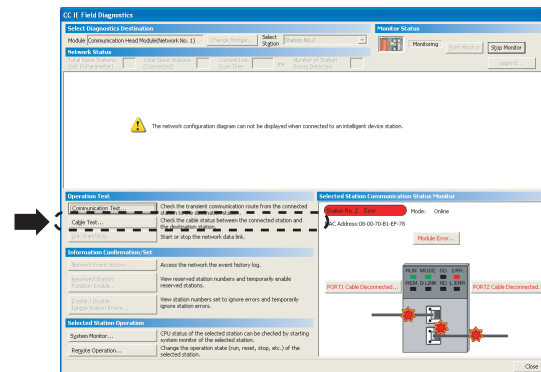

# 9.6 System Monitor

The "System Monitor" dialog box can be displayed. In the dialog box, errors that occur in a module other than the head module can also be checked. For system monitor, refer to  Page 89, Section 11.3.

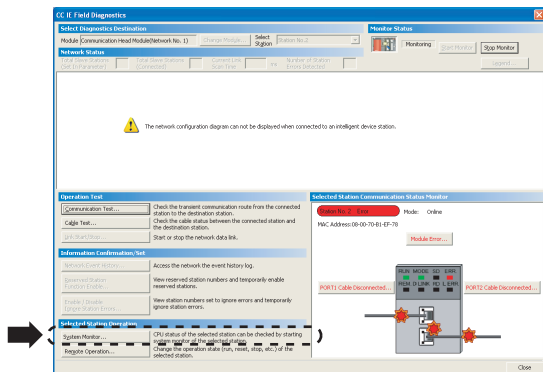

# 9.7 Remote Operation

Remote operation (RUN, STOP, and RESET operations) can be performed from GX Works2 to the head module.

1. Connect GX Works2 to the head module.
2. Start CC-Link IE Field Network diagnostics from the menu.  
 [Diagnostics] ⇨ [CC IE Field Diagnostics]
3. Click the **Remote Operation...** button in the "CC IE Field Diagnostics" dialog box. The "Remote Operation" dialog box opens.

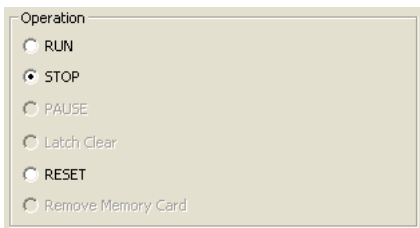
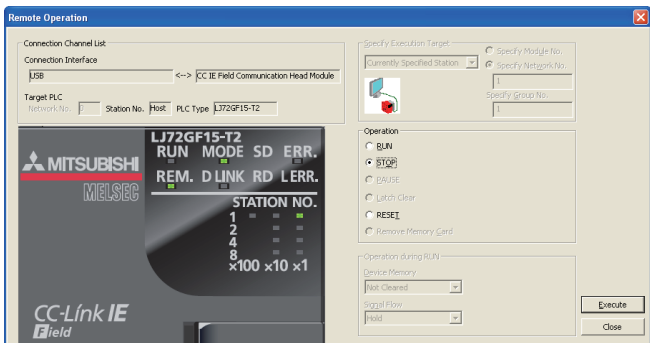

4. Select a remote operation to the head module in "Operation".

Item	Description
RUN	Select a remote operation to the head module.
STOP	<ul style="list-style-type: none"> <li>• If remote RUN is performed when the switch of the head module is set to STOP or the master station is in STOP status (including disconnected status), the head module will not enter RUN status.</li> </ul>
RESET	<ul style="list-style-type: none"> <li>• If remote RESET is performed when the switch of the head module is set to RUN, the head module will not be reset.</li> </ul>

5. Click the **Execute** button to perform the remote operation.

# CHAPTER 10 MAINTENANCE AND INSPECTION

---

This chapter describes items that must be maintained or inspected daily or periodically to properly use a programmable controller in optimal condition at all times.

## 10.1 Daily Inspection

---

This section describes items that must be inspected daily.

Check box

The modules are securely installed.

The module joint levers are properly locked.

The terminal screws of the modules are properly tightened.

Solderless terminals are physically out of contact and away from each other.

Cable connectors are fully inserted.

The terminal cover of the power supply module is securely attached.

## 10.2 Periodic Inspection

---

This section describes items that must be inspected once or twice every 6 to 12 months.

The items must be inspected as well when the equipment has been relocated or modified, or wiring layout has been changed.

Check box

- The ambient temperature is within 0 to 55 °C.
- The ambient humidity is within 5 to 95%RH.
- There is no corrosive gas.
- The voltage across 100VAC terminals is within 85V to 132VAC.
- The voltage across 200VAC terminals is within the range of 170V to 264VAC.
- The voltage across 24VDC terminals is within 15.6V to 31.2VDC.
- The modules are securely installed.
- No dust or foreign matter is present.
- No error has occurred.

# CHAPTER 11 TROUBLESHOOTING

---

This chapter describes errors that may occur in the head module, causes of the errors, and corrective actions.

## 11.1 Before Troubleshooting

---

Check that the POWER LED of the power supply module is on. If it is off, troubleshoot the CPU module.

(  MELSEC-L CPU Module User's Manual (Hardware Design, Maintenance and Inspection))

## 11.2 Troubleshooting Procedure

---

The procedure for identifying the cause of the problem and taking action is explained below.

GX Works2 is used for this. When GX Works2 is connected to the master station, the entire network status can be monitored. If the head module status cannot be monitored due to cable disconnection or any other error, directly connect GX Works2 to the head module.

This chapter describes the troubleshooting procedure taken when GX Works2 is directly connected to the head module.

(1) Procedure

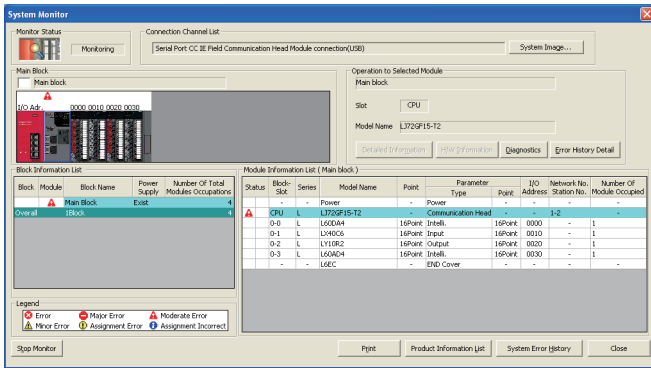

1. Connect GX Works2 to the head module, and open the "System Monitor" dialog box.

[Diagnostics] ⇒ [System Monitor]

2. Select the module in which an error has occurred.

- When the selected module is the head module

☞ Page 86, Section 11.2 (1) (a)

- When the selected module is any other than the head module

☞ Page 88, Section 11.2 (1) (b)

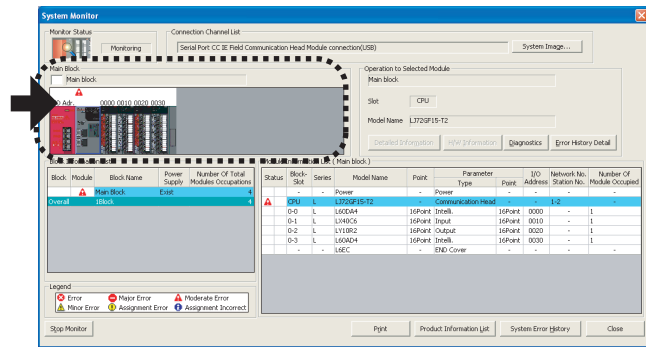

**Point**

When data link cannot be performed even though no failure is shown in "System Monitor", perform the CC-Link IE Field Network diagnostics. (☞ Page 75, CHAPTER 9)

## (a) Checking for failure of the head module

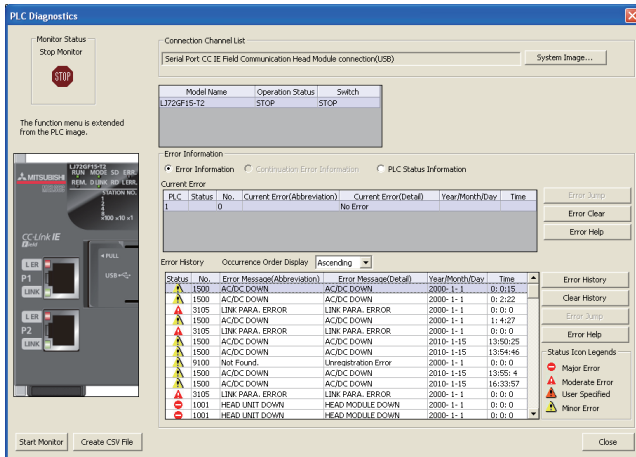

1. Selecting the head module in "System Monitor" and clicking the **Diagnostics** button will open the "PLC Diagnostics" dialog box.

## How to start CC-Link IE Field Network diagnostics

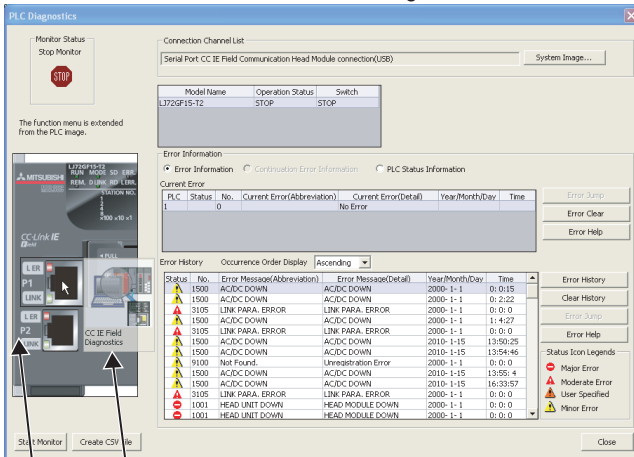

- 2) The CC-Link IE Field Diagnostics icon appears. Click the icon.
- 1) Place the mouse pointer on the port to be diagnosed.

2. Select the error that is occurring, and click the **Error Help** button to check the cause and action.

When data link cannot be performed even though no failure is shown in "PLC Diagnostics", open the CC-Link IE Field Network diagnostics screen by the operation shown left and take action.

(👉 Page 75, CHAPTER 9)



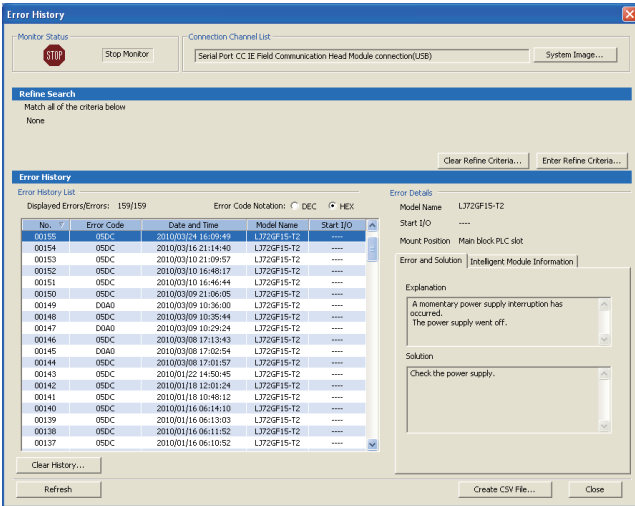

3. Reset of the head module and errors occurred before power off can be checked in the "Error History" dialog box.

[Diagnostics] ⇔ [System Monitor] ⇔  
 System Error History button

In the single "Error History" dialog box, the error history of the head module and intelligent function modules can be viewed. (Page 89, Section 11.3)

4. If data link is not available even after troubleshooting by the above operation, perform the following.

- CC-Link IE Field Network diagnostics by connecting GX Works2 to the master/local module ( Relevant master/local module user's manual)
- Checking the LEDs (Page 91, Section 11.4)
- Troubleshooting by symptom (Page 94, Section 11.5)

**(b) Checking for failure of a module other than the head module**

**1. Select a module other than the head module in the "System Monitor" dialog box, and click the**

**[Diagnostics] or [Detailed Information] button to view the diagnostics or detailed information.**

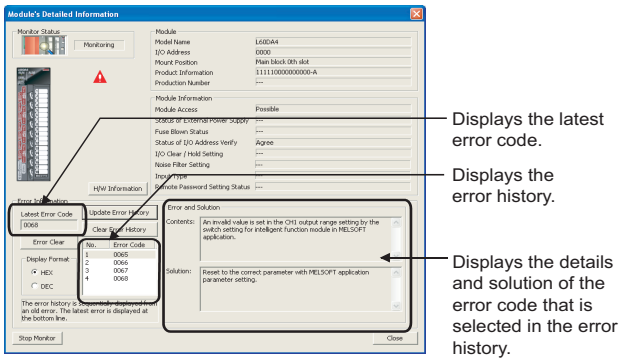

Displays the latest error code.

Displays the error history.

Displays the details and solution of the error code that is selected in the error history.

**2. Reset of the head module and errors occurred before power off can be checked in the "Error History" dialog box.**

[Diagnostics] ⇌ [System Monitor] ⇌

[System Error History] button

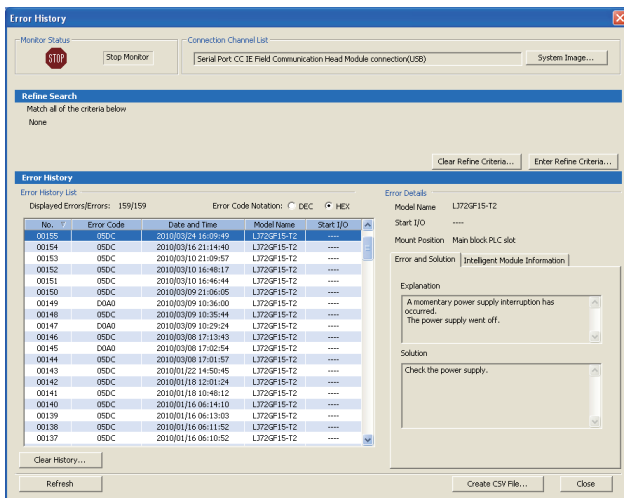

In the single "Error History" dialog box, the error history of the head module and intelligent function modules can be viewed. (Page 89, Section 11.3)

**3. If data link is not available even after troubleshooting by the above operation, perform the following.**

- Checking the LEDs (Page 91, Section 11.4)
- Troubleshooting by symptom (Page 94, Section 11.5)

# 11.3 System Error History

The history of the errors that occurred in the past can be checked so that corrective actions can be taken for each of them. Reset of the head module and errors occurred before power off can be also checked. On a single screen, error history of not only the head module but also the intelligent function modules installed with the head module can be checked.

Data of up to 100 errors can be collected. (Once the number of collected error logs exceeds 100, the oldest error logs will be deleted.)

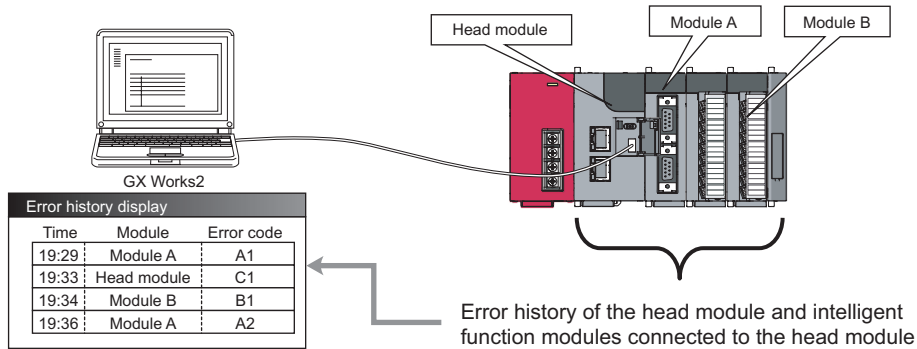

## (1) Checking the error history

1. Open the "Error History" dialog box.

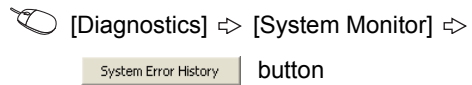

The error history is displayed. Check the error and solution and troubleshoot the problem.

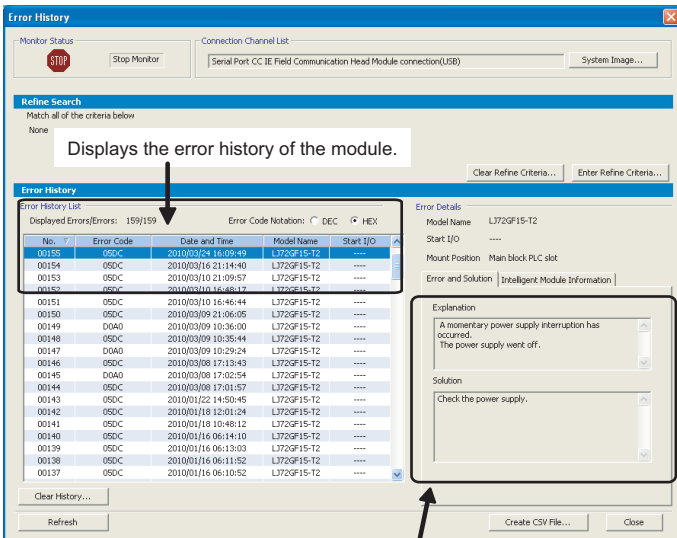

Displays the details and solution of the error selected in "Error History List."

### Point

- If error code 9900 is detected, check the error and solution of error code D\*\*\*H detected at the same time to troubleshoot the problem. Concurrently with error code 9900, error code D\*\*\*H is also detected.
- If the same error occurred continuously, only the first error record is displayed in the "Error History" dialog box.
- Selecting a module in the "Main Block" area in "System Monitor" and clicking the **Error History Detail** button will also open the "Error History" dialog box. In this case, only the error history of the module selected in "Main Block" is displayed. For details on errors of intelligent function modules, refer to the following.

Relevant intelligent function module manual

## (2) Precautions

### (a) The time and date of the error is not correctly displayed.

- Check if the master station is connected to the head module. The head module periodically collects time information from the CPU module on the master station. If the master station is not connected to the head module, the time and date of errors will not be displayed correctly. (Initial value: 2000/01/01 00:00:00)
- After acquisition of clock information from the master station, if the head module is powered off and then on, the clock will restart from the time of the power off. (The clock pauses during power off.)  
Because of this, the displayed time and date of the error occurred during initial processing may be different from the actual time and date.

### (b) The error code is not correctly displayed.

If errors occurred frequently, "\*HST.LOSS\*" may be displayed in the "Error Code" column, instead of an error code.

No.	Error Code	Date and Time	Model Name	Start I/O
00005	*HST.LOSS*	2010/03/30 11:51:41	LJ72GF15-T2	----
00004	0068	2010/03/30 11:51:45	L60DA4	0000

### (c) No error history is displayed.

In "PLC RAS" of PLC Parameter, check if the "Module Error History Collection (Intelligent Function Module)" is selected. This setting is enabled by performing "Write to PLC" in GX Works2 and resetting the head module or turning off and then on the power.

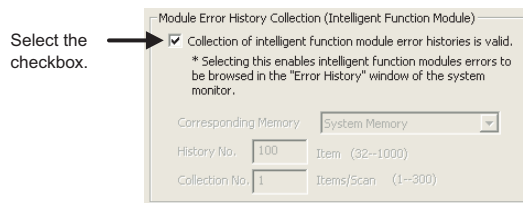

## Point

If the check box in "Module Error History Collection (Intelligent Function Module)" is cleared, error history data of intelligent function modules are not collected.

Clear the check box if a higher operation speed is desired for the head module.

# 11.4 Checking the LEDs

The following explains how to troubleshoot the system by the LEDs.

## (1) When the RUN LED turned off

Check item	Action
Is the head module installed correctly?	Connect the head module to the power supply module again.

If the above action does not solve the problem, perform the unit test on the head module to check for a hardware error. (☞ Page 45, Section 6.4)

## (2) When the RUN LED is flashing

Check item	Action
Is the switch of the head module set to RUN?	Set the switch of the head module to RUN to start data link.
Is it in the remote STOP status?	Cancel the remote STOP and start data link.
Has an error occurred in the head module?	From "System Monitor" in GX Works2, identify the cause of the error and take action. (☞ Page 84, Section 11.2)
Is the master station in the RUN state?	Place the master station into the RUN state. If the master station has stopped due to an error, troubleshoot it referring to the manual for the master station. (📖 Relevant master/local module user's manual)
Was the head module disconnected during STOP of the master station?	<ul style="list-style-type: none"> <li>Place the master station into the RUN state and reconnect the head module to the network.</li> <li>Reset the head module because it retains the STOP status of the master station.</li> </ul>

## (3) When the MODE LED turned off

Check item	Action
Is the mode of the head module set to Online?	Change the mode of the head module to Online. (☞ Page 53, Section 7.1 (1))





If the above action does not solve the problem, perform the unit test on the head module to check for a hardware error. (☞ Page 45, Section 6.4)

## (4) When the MODE LED is flashing



Check item	Action
Is the head module in preparation for the unit test?	If the switch on the head module was repeatedly switched between STOP and RESET/TEST, reset the head module and start the unit test.
Is the head module in execution of the unit test? (The ×1 or ×10 LED is flashing.)	The head module is in execution of the unit test. When the unit test is terminated, the D LINK LED turns on. Take action according to the unit test result. (☞ Page 45, Section 6.4 (1))
Is the mode of the module on the master station set to Online?	Change the mode of the module to Online. (📖 Relevant master/local module user's manual)

If the above actions do not solve the problem, perform the unit test on the head module to check for a hardware error. (☞ Page 45, Section 6.4)

## (5) When the D LINK LED turned off

Check item	Action
Is the master station connected to the network and operating normally?	<ul style="list-style-type: none"> <li>• If an error has occurred in the CPU module of the master station, remove the cause of the CPU module error. (  Relevant master/local module user's manual)</li> <li>• Connect GX Works2 to the master station, and check if the master station is performing data link by CC-Link IE Field Network diagnostics. (  Relevant master/local module user's manual)</li> </ul>
Does Ethernet cables normally operate?	<ul style="list-style-type: none"> <li>• Check if 1000BASE-T-compliant Ethernet cables are used. (  Page 27, Section 3.2)</li> <li>• Check if the station-to-station distance is 100m or less. (  Page 50, Section 6.5.3)</li> <li>• Check if the Ethernet cables are not disconnected.</li> </ul>
Are the switching hub and other stations connected to the head module normal?	Check if the switching hub and other stations are powered on.
Does the switching hub normally operate?	Check if a 1000BASE-T-compliant switching hub is used. (  Relevant master/local module user's manual)
Isn't the station number of the head module duplicated with any of other stations?	Change the duplicated station number.
Does the network No. of the head module match the number of the connected network?	Change the network No. of the head module to the number of the connected network.

If the above actions do not solve the problem, perform the following tests on the head module to check for an error.

- Unit test (  Page 45, Section 6.4)
- Cable test (  Page 80, Section 9.5)

## (6) When the D LINK LED is flashing





Check item	Action
Are the STATION NO. LEDs of the head module correctly showing the station number specified in Network Configuration Setting of the master station?	<ul style="list-style-type: none"> <li>• Have the station number of the actual head module and the one specified in Network Configuration Setting of the master station matched.</li> <li>• In GX Works2, format the PLC memory of the head module and then write PLC parameters again.</li> </ul>

If the above actions do not solve the problem, connect GX Works2 to the master station and perform the CC-Link IE Field Network diagnostics. (  Relevant master/local module user's manual)



## (7) When the ERR. LED turned on

Identify the cause of the error in GX Works2 and take action. (  Page 84, Section 11.2)



**(8) When the L ERR. LED turned on**

Check item	Action
Does Ethernet cables normally operate?	<ul style="list-style-type: none"> <li>• Check if 1000BASE-T-compliant Ethernet cables are used. (  Page 27, Section 3.2)</li> <li>• Check if the station-to-station distance is 100m or less. (  Page 50, Section 6.5.3)</li> <li>• Check if the Ethernet cables are not disconnected.</li> </ul>
Does the switching hub normally operate?	<ul style="list-style-type: none"> <li>• Check if a 1000BASE-T-compliant switching hub is used. (  Relevant master/local module user's manual)</li> <li>• Check if the switching hub is on.</li> </ul>
Do other stations connected to the head module normally operate?	Check if the systems on other stations are on.
Is the mode of the module on the master station set to Online?	Change the mode of the module to Online. (  Relevant master/local module user's manual)
Is there any noise affecting the system?	Check the wiring condition.
Is the loopback function enabled for the master station?	When the loopback function is enabled, check if the ring topology is correctly configured for the port where the L ERR. LED is on. (  Relevant master/local module user's manual)



If the above actions do not solve the problem, perform the following tests on the head module to check for an error

- Unit test (  Page 45, Section 6.4)
- Cable test (  Page 80, Section 9.5)

**(9) When the LINK LED turned off**

Check item	Action
Does Ethernet cables normally operate?	<ul style="list-style-type: none"> <li>• Check if 1000BASE-T-compliant Ethernet cables are used. (  Page 27, Section 3.2)</li> <li>• Check if the station-to-station distance is 100m or less. (  Page 50, Section 6.5.3)</li> <li>• Check if the Ethernet cables are not disconnected.</li> </ul>
Are the switching hub and other stations connected to the head module normal?	Check if the switching hub and other stations are powered on.

If the above actions do not solve the problem, perform the following tests on the head module to check for an error.

- Unit test (  Page 45, Section 6.4)
- Cable test (  Page 80, Section 9.5)

**(10)When the REM. LED is flashing**

Check item	Action
After execution of "Write to PLC", was the head module reset?	Reset the head module.
Are any forced I/O data being registered?	Cancel the registration.

**(11)When the REM. LED turned off**

Check item	Action
Has an error occurred in the head module?	From "System Monitor" in GX Works2, identify the cause of the error and take action. (  Page 84, Section 11.2)

## 11.5 Troubleshooting by Symptom

Troubleshooting methods are described by symptom. Perform these troubleshooting actions when cyclic and/or transient transmissions are not possible with the target station even though no error is detected in the head module. If an error has occurred in an intelligent function module installed with the head module, identify the cause of the error by GX Works2. (👉 Page 84, Section 11.2)

### Point

- Before starting the troubleshooting by symptom, check that the POWER LED of the power supply module is on. For troubleshooting of the power supply module, refer to the 📖 MELSEC-L CPU Module User's Manual (Hardware Design, Maintenance and Inspection).
- When the troubleshooting by symptom cannot solve the problem  
Perform the unit test on the head module to check for a hardware error. (👉 Page 45, Section 6.4)

### 11.5.1 Cyclic transmission cannot be performed.

When cyclic data are not delivered to other stations, or when cyclic data from the master station cannot be received, use the following troubleshooting methods.

Check item	Action
Is the D LINK LED of the head module on?	If the D LINK LED is flashing or off, perform the troubleshooting by the LEDs. (👉 Page 91, Section 11.4)
Are the I/O assignment settings of PLC parameter correct?	Set the I/O assignment correctly. (👉 Page 61, Section 7.1 (6))
Is the switch of the head module set to "RUN"?	Set the switch of the head module to "RUN".
Is the RUN LED of the head module on?	If the RUN LED is flashing or off, perform the troubleshooting by the LEDs. (👉 Page 91, Section 11.4)

If the above actions do not solve the problem, check the link device assignment of the master station and the refresh target device setting of refresh parameters for an error. (📖 Relevant master/local module user's manual)

### 11.5.2 Transient transmission cannot be performed.

If transient transmissions are not executable with the target station, check if the network number and station number of the head module are set. (👉 Page 53, Section 7.1 (1))

If network number and station number are set for the head module, refer to the troubleshooting pages written for the master/local module, and take action. (📖 Relevant master/local module user's manual)



## 11.6 Error Code List

---

This section describes error messages, error conditions, causes, and actions for respective error codes of the head module.

Errors of the head module are classified by error codes as shown below.

Error code	Classification	Reference
1 to 10000	Errors of the head module	Page 96, Section 11.6 (1)
D000H to DFFFH	Errors of the CC-Link IE Field Network	Page 102, Section 11.6 (2)

## (1) Error code list (1 to 10000)

The following lists the error messages, error conditions, causes, and actions of the error codes (1 to 10000).

The "■Supplementary information" in the "Error and cause" column can be confirmed by any of the following.

- PLC Diagnostics in GX Works2
- Common error information (SD5 to SD15)
- Individual error information (SD16 to SD26)

Error code	Error and cause	Action
1000		
1001	<b>[HEAD UNIT DOWN]</b>	
1002	The head module is running away or faulty.	
1003	<ul style="list-style-type: none"> <li>• Malfunction due to noise</li> <li>• Hardware failure</li> </ul>	Take action against noise, and reset the module.
1004	<b>■Supplementary information</b>	If this error occurs again, the hardware of the head module may be faulty.
1005	<ul style="list-style-type: none"> <li>• Common information: -</li> <li>• Individual information: -</li> </ul>	(Please consult your local Mitsubishi service center or representative, explaining a detailed description of the problem.)
1006	<b>■Diagnostic timing</b>	
1009	<ul style="list-style-type: none"> <li>• Any time</li> </ul>	
1035		
1090	<b>[HEAD UNIT DOWN]</b> The head module is running away or faulty.	
	<ul style="list-style-type: none"> <li>• Malfunction due to noise</li> <li>• Hardware failure</li> </ul>	Take action against noise, and reset the module.
	<b>■Supplementary information</b>	If this error occurs again, the hardware of the head module may be faulty.
	<ul style="list-style-type: none"> <li>• Common information: -</li> <li>• Individual information: Breakdown information</li> </ul>	(Please consult your local Mitsubishi service center or representative, explaining a detailed description of the problem.)
	<b>■Diagnostic timing</b>	
	<ul style="list-style-type: none"> <li>• Any time</li> </ul>	
1101	<b>[RAM ERROR]</b>	
	The RAM built in the head module is faulty.	
1102	<b>■Supplementary information</b>	Take action against noise, and reset the module.
	<ul style="list-style-type: none"> <li>• Common information: -</li> <li>• Individual information: -</li> </ul>	If this error occurs again, the hardware of the head module may be faulty.
1103	<b>■Diagnostic timing</b>	(Please consult your local Mitsubishi service center or representative, explaining a detailed description of the problem.)
1104	<ul style="list-style-type: none"> <li>• When powered on or reset</li> </ul>	
1161	<b>[RAM ERROR]</b>	
	The data in the device memory built in the head module were overwritten.	
	<b>■Supplementary information</b>	Take action against noise, and reset the module.
	<ul style="list-style-type: none"> <li>• Common information: -</li> <li>• Individual information: -</li> </ul>	If this error occurs again, the hardware of the head module may be faulty.
	<b>■Diagnostic timing</b>	(Please consult your local Mitsubishi service center or representative, explaining a detailed description of the problem.)
	<ul style="list-style-type: none"> <li>• Any time</li> </ul>	
1310	<b>[I/O INT. ERROR]</b>	
	An interrupt occurred even though there is no module that can issue an interrupt.	
	<b>■Supplementary information</b>	The hardware of any of the installed modules is faulty. Check the installed modules, and replace the faulty module. (Please consult your local Mitsubishi service center or representative, explaining a detailed description of the problem.)
	<ul style="list-style-type: none"> <li>• Common information: -</li> <li>• Individual information: -</li> </ul>	
	<b>■Diagnostic timing</b>	
	<ul style="list-style-type: none"> <li>• When an interrupt occurred</li> </ul>	
1311	<b>[I/O INT. ERROR]</b>	
	An interrupt request from a module installed with the head module was detected.	
	<b>■Supplementary information</b>	The hardware of any of the installed modules is faulty. Check the installed modules, and replace the faulty module. (Please consult your local Mitsubishi service center or representative, explaining a detailed description of the problem.)
	<ul style="list-style-type: none"> <li>• Common information: -</li> <li>• Individual information: -</li> </ul>	
	<b>■Diagnostic timing</b>	
	<ul style="list-style-type: none"> <li>• When an interrupt occurred</li> </ul>	

Error code	Error and cause	Action
1401	<p><b>[SP. UNIT DOWN]</b></p> <ul style="list-style-type: none"> <li>In the initial processing, no response is returned from the intelligent function module.</li> <li>The buffer memory size of the intelligent function module is abnormal.</li> <li>No response is returned from the intelligent function module.</li> <li>When the error occurs, the start I/O number of the corresponding intelligent function module is stored in the common information area.</li> </ul> <p>■ <b>Supplementary information</b></p> <ul style="list-style-type: none"> <li>Common information: Module No. (Slot No.)</li> <li>Individual information: -</li> </ul> <p>■ <b>Diagnostic timing</b></p> <ul style="list-style-type: none"> <li>When powered on, reset, or accessing an intelligent function module</li> </ul>	<p>Reset the head module.</p> <p>If this error occurs again, the hardware of the head module, I/O module, intelligent function module, or END cover may be faulty. (Please consult your local Mitsubishi service center or representative, explaining a detailed description of the problem.)</p>
1403	<p><b>[SP. UNIT DOWN]</b></p> <ul style="list-style-type: none"> <li>No response is returned from the intelligent function module.</li> <li>An error occurred in an intelligent function module was detected.</li> <li>Any of the I/O modules (including intelligent function modules) is being disconnected during its operation, or was disconnected.</li> </ul> <p>■ <b>Supplementary information</b></p> <ul style="list-style-type: none"> <li>Common information: Module No. (Slot No.)</li> <li>Individual information: -</li> </ul> <p>■ <b>Diagnostic timing</b></p> <ul style="list-style-type: none"> <li>Any time</li> </ul>	<p>Reset the head module.</p> <p>If this error occurs again, the hardware of the head module, I/O module, intelligent function module, or END cover may be faulty. (Please consult your local Mitsubishi service center or representative, explaining a detailed description of the problem.)</p>
1500	<p><b>[AC/DC DOWN]</b></p> <ul style="list-style-type: none"> <li>Momentary supply power failure occurred.</li> <li>The supply power turned off.</li> </ul> <p>■ <b>Supplementary information</b></p> <ul style="list-style-type: none"> <li>Common information: -</li> <li>Individual information: -</li> </ul> <p>■ <b>Diagnostic timing</b></p> <ul style="list-style-type: none"> <li>Any time</li> </ul>	<p>Check the supply power.</p>
1610	<p><b>[FLASH ROM ERROR]</b></p> <p>The number of writes to the flash ROM exceeded 100,000 times. (Number of writes &gt; 100,000)</p> <p>■ <b>Supplementary information</b></p> <ul style="list-style-type: none"> <li>Common information: -</li> <li>Individual information: -</li> </ul> <p>■ <b>Diagnostic timing</b></p> <ul style="list-style-type: none"> <li>When writing data to ROM</li> </ul>	<ul style="list-style-type: none"> <li>Replace the head module.</li> <li>In "Communication Head Setting" of PLC Parameter, clear the check box so that data of the error history and system error history will not be held at the time of power off or reset.</li> </ul>
1700	<p><b>[BUS TIMEOUT ERR.]</b></p> <p>Failure of the system bus was detected.</p> <p>■ <b>Supplementary information</b></p> <ul style="list-style-type: none"> <li>Common information: -</li> <li>Individual information: -</li> </ul> <p>■ <b>Diagnostic timing</b></p> <ul style="list-style-type: none"> <li>Any time</li> </ul>	<p>Reset the head module.</p> <p>If this error occurs again, this module, I/O module, intelligent function module, or END cover may be faulty.</p>
1710	<p><b>[UNIT BUS ERROR]</b></p> <ul style="list-style-type: none"> <li>Failure of the system bus was detected.</li> <li>Failure of a connected module was detected.</li> </ul> <p>■ <b>Supplementary information</b></p> <ul style="list-style-type: none"> <li>Common information: -</li> <li>Individual information: -</li> </ul> <p>■ <b>Diagnostic timing</b></p> <ul style="list-style-type: none"> <li>Any time</li> </ul>	<p>(Please consult your local Mitsubishi service center or representative, explaining a detailed description of the problem.)</p>

Error code	Error and cause	Action
1720	<p><b>[END COVER ERR.]</b> Failure of the END cover was detected.</p> <p>■ <b>Supplementary information</b></p> <ul style="list-style-type: none"> <li>• Common information: -</li> <li>• Individual information: -</li> </ul> <p>■ <b>Diagnostic timing</b></p> <ul style="list-style-type: none"> <li>• When powered on or reset</li> </ul>	<ul style="list-style-type: none"> <li>• Replace the END cover.</li> <li>• Reset the head module.</li> </ul>
1730	<p><b>[SYSTEM RST ERR.]</b> Failure of the system bus was detected.</p> <p>■ <b>Supplementary information</b></p> <ul style="list-style-type: none"> <li>• Common information: -</li> <li>• Individual information: -</li> </ul> <p>■ <b>Diagnostic timing</b></p> <ul style="list-style-type: none"> <li>• When powered on or reset</li> </ul>	<p>If this error occurs again, the hardware of the head module, intelligent function module, or END cover may be faulty. (Please consult your local Mitsubishi service center or representative, explaining a detailed description of the problem.)</p>
2030	<p><b>[NO END COVER]</b> There is no END cover.</p> <p>■ <b>Supplementary information</b></p> <ul style="list-style-type: none"> <li>• Common information: -</li> <li>• Individual information: -</li> </ul> <p>■ <b>Diagnostic timing</b></p> <ul style="list-style-type: none"> <li>• When powered on or reset</li> </ul>	<ul style="list-style-type: none"> <li>• Install an END cover.</li> <li>• Check if the modules are correctly connected, referring to the configuration of the modules in the System Monitor dialog box.</li> <li>• Reset the head module.</li> </ul>
2031	<p><b>[NO END COVER]</b> There is no END cover.</p> <p>■ <b>Supplementary information</b></p> <ul style="list-style-type: none"> <li>• Common information: -</li> <li>• Individual information: -</li> </ul> <p>■ <b>Diagnostic timing</b></p> <ul style="list-style-type: none"> <li>• Any time</li> </ul>	<p>If this error occurs again, the hardware of the head module, I/O module, intelligent function module, or END cover may be faulty. (Please consult your local Mitsubishi service center or representative, explaining a detailed description of the problem.)</p>
2040	<p><b>[UNIT BAD CONNECT]</b></p> <ul style="list-style-type: none"> <li>• The information is different from the I/O module information at the time of power on.</li> <li>• Any of the I/O modules (including intelligent function modules) is being disconnected during its operation, or was disconnected.</li> </ul> <p>■ <b>Supplementary information</b></p> <ul style="list-style-type: none"> <li>• Common information: Module No. (Slot No.)</li> <li>• Individual information: -</li> </ul> <p>■ <b>Diagnostic timing</b></p> <ul style="list-style-type: none"> <li>• Any time</li> </ul>	<ul style="list-style-type: none"> <li>• Read common information on the error using the programming tool, check the module corresponding to the value (module No.) and replace the module.</li> <li>• Monitor SD1400 to SD1431 on the programming tool, check the module corresponding to the bit indicating "1", and replace the module.</li> <li>• Reset the head module.</li> </ul> <p>If this error occurs again, the hardware of the head module, I/O module, intelligent function module, or END cover may be faulty. (Please consult your local Mitsubishi service center or representative, explaining a detailed description of the problem.)</p>
2100	<p><b>[SP. UNIT LAY ERR.]</b></p> <ul style="list-style-type: none"> <li>• In "I/O Assignment" of PLC Parameter, "Intelligent" is set for the position of an I/O module. Or vice versa.</li> <li>• In "I/O Assignment" of PLC Parameter, the intelligent function module switch setting is set for the module that does not support it.</li> <li>• In "I/O Assignment" of PLC Parameter, the number of points smaller than that of the actual intelligent function module is assigned.</li> </ul> <p>■ <b>Supplementary information</b></p> <ul style="list-style-type: none"> <li>• Common information: Module No. (Slot No.)</li> <li>• Individual information: -</li> </ul> <p>■ <b>Diagnostic timing</b></p> <ul style="list-style-type: none"> <li>• When powered on or reset</li> </ul>	<ul style="list-style-type: none"> <li>• Correct the I/O Assignment setting of PLC Parameter, according to the actual condition of the intelligent function module(s) and head module.</li> <li>• In "I/O Assignment" of PLC Parameter, delete the intelligent function module switch settings.</li> </ul>
2107	<p><b>[SP. UNIT LAY ERR.]</b> A start X/Y set in "I/O Assignment" of PLC Parameter is overlapped with that of another module.</p> <p>■ <b>Supplementary information</b></p> <ul style="list-style-type: none"> <li>• Common information: Module No. (Slot No.)</li> <li>• Individual information: -</li> </ul> <p>■ <b>Diagnostic timing</b></p> <ul style="list-style-type: none"> <li>• When powered on or reset</li> </ul>	<p>Correct the I/O Assignment setting of PLC Parameter, according to the actual condition of the intelligent function module(s) and I/O module(s).</p>

Error code	Error and cause	Action
2124	<p><b>[SP. UNIT LAY ERR.]</b></p> <ul style="list-style-type: none"> <li>The number of connected modules exceeded 10.</li> <li>A module is installed in the position corresponding to the I/O points of 4096 or greater.</li> <li>A module is installed across the boundary of 4096 I/O points.</li> </ul> <p>■ <b>Supplementary information</b></p> <ul style="list-style-type: none"> <li>Common information: -</li> <li>Individual information: -</li> </ul> <p>■ <b>Diagnostic timing</b></p> <ul style="list-style-type: none"> <li>When powered on or reset</li> </ul>	<ul style="list-style-type: none"> <li>Reduce the number of connected modules to 10 or less.</li> <li>Remove the module installed in the position corresponding to the I/O points of 4096 or greater.</li> <li>Replace the end module with a module so that the number of occupied points does not exceed 4096.</li> <li>Reset the head module.</li> </ul> <p>If this error occurs again, the hardware of the head module, I/O module, intelligent function module, or END cover may be faulty. (Please consult your local Mitsubishi service center or representative, explaining a detailed description of the problem.)</p>
2125	<p><b>[SP. UNIT LAY ERR.]</b></p> <ul style="list-style-type: none"> <li>An inappropriate module was installed.</li> <li>No response is returned from the intelligent function module.</li> </ul> <p>■ <b>Supplementary information</b></p> <ul style="list-style-type: none"> <li>Common information: Module No. (Slot No.)</li> <li>Individual information: -</li> </ul> <p>■ <b>Diagnostic timing</b></p> <ul style="list-style-type: none"> <li>When powered on or reset</li> </ul>	<ul style="list-style-type: none"> <li>Install an appropriate module.</li> <li>Reset the head module.</li> </ul> <p>If this error occurs again, the hardware of the head module, I/O module, intelligent function module, or END cover may be faulty. (Please consult your local Mitsubishi service center or representative, explaining a detailed description of the problem.)</p>
2170	<p><b>[SYSTEM LAY ERR.]</b></p> <p>An inappropriate module was installed.</p> <p>■ <b>Supplementary information</b></p> <ul style="list-style-type: none"> <li>Common information: -</li> <li>Individual information: -</li> </ul> <p>■ <b>Diagnostic timing</b></p> <p>When powered on or reset</p>	<ul style="list-style-type: none"> <li>Disconnect the inappropriate module.</li> <li>Reset the head module.</li> </ul> <p>If this error occurs again, the hardware of the head module, I/O module, intelligent function module, or END cover may be faulty. (Please consult your local Mitsubishi service center or representative, explaining a detailed description of the problem.)</p>
3000	<p><b>[PARAMETER ERROR]</b></p> <p>In PLC Parameter, the number of points for empty slots is not set within the range allowed for the head module.</p> <p>■ <b>Supplementary information</b></p> <ul style="list-style-type: none"> <li>Common information: File name/Drive name</li> <li>Individual information: Parameter No.</li> </ul> <p>■ <b>Diagnostic timing</b></p> <ul style="list-style-type: none"> <li>When powered on or reset, or when writing to PLC</li> </ul>	<ul style="list-style-type: none"> <li>Read detailed error information using the programming tool, and check and correct the parameter corresponding to the value (parameter No.).</li> <li>Write the corrected parameters to the head module again, and reset or reapply power to the head module.</li> </ul> <p>If this error occurs again, the hardware of the head module may be faulty. (Please consult your local Mitsubishi service center or representative, explaining a detailed description of the problem.)</p>
3001	<p><b>[PARAMETER ERROR]</b></p> <p>The parameters are corrupted.</p> <p>■ <b>Supplementary information</b></p> <ul style="list-style-type: none"> <li>Common information: File name/Drive name</li> <li>Individual information: Parameter No.</li> </ul> <p>■ <b>Diagnostic timing</b></p> <ul style="list-style-type: none"> <li>When powered on or reset, or when writing to PLC</li> </ul>	<ul style="list-style-type: none"> <li>Read detailed error information using the programming tool, and check and correct the parameter corresponding to the value (parameter No.).</li> <li>Write the corrected parameters to the head module again, and reset or reapply power to the head module.</li> </ul> <p>If this error occurs again, the hardware of the head module may be faulty. (Please consult your local Mitsubishi service center or representative, explaining a detailed description of the problem.)</p>
3004	<p><b>[PARAMETER ERROR]</b></p> <p>The parameter file is incorrect. Or, the contents of the file are not parameters.</p> <p>■ <b>Supplementary information</b></p> <ul style="list-style-type: none"> <li>Common information: File name/Drive name</li> <li>Individual information: Parameter No.</li> </ul> <p>■ <b>Diagnostic timing</b></p> <ul style="list-style-type: none"> <li>When powered on or reset, or when writing to PLC</li> </ul>	<p>Check if the type of the parameter file is shown as "****.QPA" and if the file contains parameters.</p>
3105	<p><b>[LINK PARA. ERROR]</b></p> <ul style="list-style-type: none"> <li>Although the number of modules is set to 1 or more in Network Parameter for CC-Link, the number of actually connected modules is 0.</li> <li>The start I/O number set in the parameter setting is different from the actual I/O number.</li> <li>In the Network Parameter setting for CC-Link, any of the station types is mismatched.</li> </ul> <p>■ <b>Supplementary information</b></p> <ul style="list-style-type: none"> <li>Common information: File name/Drive name</li> <li>Individual information: Parameter No.</li> </ul> <p>■ <b>Diagnostic timing</b></p> <ul style="list-style-type: none"> <li>When powered on or reset</li> </ul>	<p>Correct the Network Parameter settings, and then write them. If the error occurs again even after the correction, the module may be faulty. (Please consult your local Mitsubishi service center or representative, explaining a detailed description of the problem.)</p>

Error code	Error and cause	Action
3106	<p><b>[LINK PARA. ERROR]</b> A network refresh parameter for CC-Link is out of range.</p> <p>■<b>Supplementary information</b></p> <ul style="list-style-type: none"> <li>• Common information: File name/Drive name</li> <li>• Individual information: Parameter No.</li> </ul> <p>■<b>Diagnostic timing</b></p> <ul style="list-style-type: none"> <li>• When powered on or reset</li> </ul>	<p>Correct the Network Parameter settings, and then write them. If the error occurs again even after the correction, the module may be faulty. (Please consult your local Mitsubishi service center or representative, explaining a detailed description of the problem.)</p>
3107	<p><b>[LINK PARA. ERROR]</b></p> <ul style="list-style-type: none"> <li>• The CC-Link parameter setting is not normal.</li> <li>• The mode not available for the installed CC-Link module version is set.</li> </ul> <p>■<b>Supplementary information</b></p> <ul style="list-style-type: none"> <li>• Common information: File name/Drive name</li> <li>• Individual information: Parameter No.</li> </ul> <p>■<b>Diagnostic timing</b></p> <ul style="list-style-type: none"> <li>• When powered on or reset</li> </ul>	<p>Correct the parameter setting.</p>
3300	<p><b>[SP. PARA ERROR]</b> The start I/O number for the intelligent function module set in GX Works2 is different from the actual one.</p> <p>■<b>Supplementary information</b></p> <ul style="list-style-type: none"> <li>• Common information: File name/Drive name</li> <li>• Individual information: Parameter No.</li> </ul> <p>■<b>Diagnostic timing</b></p> <ul style="list-style-type: none"> <li>• When powered on or reset, or when writing to PLC</li> </ul>	<p>Correct the parameter setting.</p>
3301	<p><b>[SP. PARA ERROR]</b></p> <ul style="list-style-type: none"> <li>• Auto refresh parameters for the intelligent function module are out of range.</li> <li>• The intelligent function module set in GX Works2 is different from the actually installed module.</li> </ul> <p>■<b>Supplementary information</b></p> <ul style="list-style-type: none"> <li>• Common information: File name/Drive name</li> <li>• Individual information: Parameter No.</li> </ul> <p>■<b>Diagnostic timing</b></p> <ul style="list-style-type: none"> <li>• When powered on or reset, or when writing to PLC</li> </ul>	<p>Correct the parameter setting.</p>
3302	<p><b>[SP. PARA ERROR]</b> Intelligent function module parameters are not normal.</p> <p>■<b>Supplementary information</b></p> <ul style="list-style-type: none"> <li>• Common information: File name/Drive name</li> <li>• Individual information: Parameter No.</li> </ul> <p>■<b>Diagnostic timing</b></p> <ul style="list-style-type: none"> <li>• When powered on or reset, or when writing to PLC</li> </ul>	<p>Correct the parameter setting.</p>
3400	<p><b>[REMOTE PASS. ERR.]</b> The start I/O number of the remote password target module is set to any other than 0000H to 0FF0H.</p> <p>■<b>Supplementary information</b></p> <ul style="list-style-type: none"> <li>• Common information: -</li> <li>• Individual information: -</li> </ul> <p>■<b>Diagnostic timing</b></p> <ul style="list-style-type: none"> <li>• When powered on or reset</li> </ul>	<p>Change the start I/O number of the target module to a number within the range of 0000H to 0FF0H.</p>
3401	<p><b>[REMOTE PASS. ERR.]</b> The position specified with the start I/O number in the remote password setting is abnormal.</p> <ul style="list-style-type: none"> <li>• No module is installed at the position.</li> <li>• An intelligent function module other than the serial communication module is installed at the position.</li> </ul> <p>■<b>Supplementary information</b></p> <ul style="list-style-type: none"> <li>• Common information: -</li> <li>• Individual information: -</li> </ul> <p>■<b>Diagnostic timing</b></p> <ul style="list-style-type: none"> <li>• When powered on or reset</li> </ul>	<p>Install an intelligent function module that supports the remote password function in the position specified with the I/O number in the remote password setting.</p>

Error code	Error and cause	Action
5000	<p><b>[WDT ERROR]</b></p> <ul style="list-style-type: none"> <li>• I/O refresh processing time exceeded 200ms. Momentary power failure occurred frequently.</li> </ul> <p>■ <b>Supplementary information</b></p> <ul style="list-style-type: none"> <li>• Common information: Time (200ms)</li> <li>• Individual information: Time (value actually measured)</li> </ul>	Modify the power supply system to prevent momentary power failure.
5001	<p>■ <b>Diagnostic timing</b></p> <ul style="list-style-type: none"> <li>• Any time</li> </ul>	
9900	<p><b>[NETWORK ERROR]</b></p> <p>A CC-Link IE Field Network error has occurred.</p> <p>■ <b>Supplementary information</b></p> <ul style="list-style-type: none"> <li>• Common information: -</li> <li>• Individual information: -</li> </ul> <p>■ <b>Diagnostic timing</b></p> <ul style="list-style-type: none"> <li>• Any time</li> </ul>	<ul style="list-style-type: none"> <li>• Check the detailed module failure by CC-Link IE Field Network diagnostics, and take action according to the display.</li> <li>• In the system error history of System Monitor, confirm the error code of the network error detected at the time.</li> </ul>

## (2) Error code list (D000H to DFFFH)

The following lists the error messages, error conditions, causes, and actions of the error codes (D000H to DFFFH).

Error code	Error	Action
D0A0H	Transient data transmission response wait timeout	<ul style="list-style-type: none"> <li>• If the own station or target station was disconnected from the network, identify the cause of the disconnection and take action.</li> <li>• When the mode of the master station is "Online (High Speed Mode)", change it to "Online (Normal Mode)" and retry the operation.</li> <li>• When the receiving station encountered overloading of transient data, reduce the frequency of transient transmission and then retry the operation.</li> </ul>
D0A1H	Transient data transmission completion wait timeout	<ul style="list-style-type: none"> <li>• Check if the cables and switching hub are connected properly.</li> <li>• Exchange the cables between PORT1 and PORT2 and retry the operation.</li> <li>• Reduce the frequency of transient transmission and then retry the operation.</li> <li>• Execute a unit test for the head module. If a failure is detected again, the hardware of the head module may be faulty. Please consult your local Mitsubishi service center or representative, explaining a detailed description of the problem.</li> </ul>
D0A2H	Transient data transmission processing wait timeout	<ul style="list-style-type: none"> <li>• Reduce the frequency of transient transmission and then retry the operation.</li> <li>• Check if the cables and switching hub of the request source are connected properly.</li> </ul>
D0A3H	Transient data transmission error	<ul style="list-style-type: none"> <li>• If the own station or target station was disconnected from the network, identify the cause of the disconnection and take action.</li> <li>• Correct the target station number of the transient data, and retry the operation.</li> <li>• If the target station of the transient data resides in another network, check if the routing parameters for respective stations are correctly set, and take corrective action.</li> </ul>
D0A4H to D0A6H	Transient transmission failed	<ul style="list-style-type: none"> <li>• Check if the cables and switching hub are connected properly.</li> <li>• Exchange the cables between PORT1 and PORT2 and retry the operation.</li> <li>• Reduce the frequency of transient transmission and then retry the operation.</li> <li>• Execute a unit test for the head module. If a failure is detected again, the hardware of the head module may be faulty. Please consult your local Mitsubishi service center or representative, explaining a detailed description of the problem.</li> </ul>
D0A7H	Transient reception failed	<ul style="list-style-type: none"> <li>• Check if the cables and switching hub are connected properly.</li> <li>• Exchange the cables between PORT1 and PORT2 and retry the operation.</li> <li>• Reduce the frequency of transient transmission and then retry the operation.</li> <li>• Execute a unit test for the head module. If a failure is detected again, the hardware of the head module may be faulty. Please consult your local Mitsubishi service center or representative, explaining a detailed description of the problem.</li> </ul>
D0E0H	Station type mismatch	In "Network Configuration Setting" of the master station, change the station type of the head module to "Intelligent Device Station."



Error code	Error	Action
D0E1H	Own station specified as reserved station	<ul style="list-style-type: none"> <li>• In "Network Configuration Setting" of the master station, cancel the reserved station setting.</li> <li>• Change the station number of the head module to a station number that is not reserved.</li> </ul>
D0E2H	Station No. duplication (own station)	<ul style="list-style-type: none"> <li>• Change the station number so that it will not be duplicated with any other station number.</li> <li>• After taking the above action, power off and then on all the stations that detected the station number duplication error, or reset them.</li> </ul>
D0E3H	Own station No. out of range	Add station information on the head module to "Network Configuration Setting" of the master station.
D200H	Double transient data received	<ul style="list-style-type: none"> <li>• Check the network status using the CC-Link IE Field Network diagnostics of the programming tool.</li> <li>• Check if the cables and switching hub are connected properly.</li> <li>• If the request source resides in another network, check if the routing parameters are correctly set, and take corrective action.</li> </ul>
D201H	Header information error in transient data	Correct the header information at the request source, and retry the operation.
D202H	Send buffer full	<ul style="list-style-type: none"> <li>• Reduce the frequency of transient transmission and then retry the operation.</li> <li>• When the mode of the master station is "Online (High Speed Mode)", change it to "Online (Normal Mode)" and retry the operation.</li> <li>• Check if the cables and switching hub are connected properly.</li> </ul>
D203H	Read/write address error in transient data	Correct the read/write address at the request source, and retry the operation.
D204H	Network No. error in transient data	<ul style="list-style-type: none"> <li>• Correct the network number at the request source, and retry the operation.</li> <li>• If the request source resides in another network, check if the routing parameters are correctly set, and take corrective action.</li> </ul>
D205H	Target station No. error in transient data	Correct the target station number at the request source, and retry the operation.
D206H	Network No. error in transient data	<ul style="list-style-type: none"> <li>• Correct the network number at the request source, and retry the operation.</li> <li>• If the request source resides in another network, check if the routing parameters are correctly set, and take corrective action.</li> </ul>
D207H	Incorrect number of relays specified in transient data	<ul style="list-style-type: none"> <li>• Correct the system configuration to reduce the number of relay stations to seven or less.</li> <li>• Check if the routing parameters are correctly set, and take corrective action.</li> </ul>
D208H	Network No. error in transient data	<ul style="list-style-type: none"> <li>• Correct the network number at the request source, and retry the operation.</li> <li>• If the request source resides in another network, check if the routing parameters are correctly set, and take corrective action.</li> </ul>
D209H to D20AH	Target station No. error in transient data	Check the target station number at the request source, and retry the operation.
D20BH	Specified master station No. error in transient data	
D20CH	Current master station No. error in transient data	

Error code	Error	Action
D20DH	Transient data transmission completion wait timeout	<ul style="list-style-type: none"> <li>• Check the network status using the CC-Link IE Field Network diagnostics of the programming tool.</li> <li>• When the own station or target station detected an error, identify the cause of the error and take action.</li> <li>• Reduce the frequency of transient transmission and then retry the operation.</li> <li>• When the mode of the master station is "Online (High Speed Mode)", change it to "Online (Normal Mode)" and retry the operation.</li> <li>• Check if the cables and switching hub of the request source are connected properly.</li> </ul>
D20EH	Header information error in transient data	Correct the header information at the request source, and retry the operation.
D20FH	Target station No. error in transient data	Check if the command can be requested to all or a group of stations at the request source, and retry the operation.
D210H	Target station No. error in transient data	Correct the header information at the request source, and retry the operation.
D211H	Own station No. undefined (dedicated instruction)	Set the station number in the parameter setting, and retry the operation.
D212H	Transient transmission failed	<ul style="list-style-type: none"> <li>• Check if the cables and switching hub of the request source are connected properly.</li> <li>• Exchange the cables between PORT1 and PORT2 and retry the operation.</li> <li>• Reduce the frequency of transient transmission and then retry the operation.</li> </ul>
D213H	Transient data request error	<ul style="list-style-type: none"> <li>• Correct the request command at the request source, and retry the operation.</li> <li>• Check the first five digits of the serial number of the module. If the module does not support the used function, replace it with the module with the latest version.</li> </ul>
D214H	Transient data request error	Correct the number of data at the request source, and retry the operation.
D216H to D217H	Transient data request error	Correct the request command at the request source, and retry the operation.
D218H	Transient data request error	At the request source, correct the number of the data to be read from or written to the device, and retry the operation.
D219H	Transient data request error	Correct the attribute code at the request source, and retry the operation.
D21AH	Transient data request error	Correct the access code at the request source, and retry the operation.
D21BH to D21CH	Head module request error	<ul style="list-style-type: none"> <li>• A malfunction may have occurred due to noise. Check the wire and cable distances and grounding condition of each device, and take measures against noise.</li> <li>• Execute a unit test for the head module. If a failure is detected again, the hardware of the head module may be faulty. Please consult your local Mitsubishi service center or representative, explaining a detailed description of the problem.</li> </ul>
D21DH	Network No. error in transient data	<ul style="list-style-type: none"> <li>• A cable test cannot be applied to a network of a different network number. Correct the data in "Testing Station Setting", and retry the cable test.</li> <li>• Transient data that is not applicable to a different network were received. Correct the network number or target station number at the request source, and retry the operation.</li> </ul>
D21EH	Target station No. error in transient data	<ul style="list-style-type: none"> <li>• The communication test cannot be executed with the relay station(s) specified. Correct "Communication Destination Setting", and then execute the communication test again.</li> <li>• Transient data of the application type that is not executable for the own station were received. Correct the application type or target station number at the request source, and retry the operation.</li> </ul>

Error code	Error	Action
D21FH	Target station type error (dedicated instruction)	The SEND instruction is not applicable to head modules. Modify the programs of the master and local stations so that the SEND instruction will not be used.
D222H	Transient data request error	Correct the request command at the request source, and retry the operation.
D247H	Double dedicated instructions received	<ul style="list-style-type: none"> <li>• Check the network status using the CC-Link IE Field Network diagnostics of the programming tool.</li> <li>• Check if the cables and switching hub of the request source are connected properly.</li> <li>• If the request source resides in another network, check if the routing parameters are correctly set, and take corrective action.</li> </ul>
D280H	Transient data request error	Correct the request command at the request source, and retry the operation.
D281H	Transient reception failed	<ul style="list-style-type: none"> <li>• Check the network status using the CC-Link IE Field Network diagnostics of the programming tool.</li> <li>• When the receiving station encountered overloading of transient data, send the data from the source after a give time has elapsed.</li> </ul>
D282H	Receive queue full	<ul style="list-style-type: none"> <li>• Check the network status using the CC-Link IE Field Network diagnostics of the programming tool.</li> <li>• When the receiving station encountered overloading of transient data, send the data from the source after a give time has elapsed.</li> </ul>
D283H	Transient transmission failed	<ul style="list-style-type: none"> <li>• Check the network status using the CC-Link IE Field Network diagnostics of the programming tool.</li> <li>• Exchange the cables between PORT1 and PORT2 of the request source and retry the operation.</li> <li>• Reduce the frequency of transient transmission and then retry the operation.</li> </ul>
D2A0H	Receive buffer full	<ul style="list-style-type: none"> <li>• Check the network status using the CC-Link IE Field Network diagnostics of the programming tool.</li> <li>• When the receiving station encountered overloading of transient data, send the data from the source after a give time has elapsed.</li> </ul>
D2A1H	Send buffer full	<ul style="list-style-type: none"> <li>• Reduce the frequency of transient transmission and then retry the operation.</li> <li>• Check if the cables and switching hub of the request source are connected properly.</li> </ul>
D2A2H	Transmission completion wait timer timeout	<ul style="list-style-type: none"> <li>• Reduce the frequency of transient transmission and then retry the operation.</li> <li>• When the mode of the master station is "Online (High Speed Mode)", change it to "Online (Normal Mode)" and retry the operation.</li> <li>• Check if the cables and switching hub of the request source are connected properly.</li> <li>• Correct the number of link dedicated instructions that is simultaneously executed within the range (for details, refer to "Precautions for link dedicated instructions" in the user's manual for the master/local module used).</li> </ul>
D2A3H	Data length error in transient data	Adjust the number of data (frame length) at the request source, and retry the operation.
D2A4H	Header information error in transient data	Correct the header information at the request source, and retry the operation.
D2A5H	Target station No. error in transient data	Correct the target station number at the request source, and retry the operation.
D2A6H	Transient data request source No. error	Correct the request source number at the request source, and retry the operation.
D2A7H to D2A8H	Header information error in transient data	Correct the header information at the request source, and retry the operation.

Error code	Error	Action
D2A9H	Target network No. error in transient data	Correct the target network number at the request source, and retry the operation.
D2AAH	Target station No. error in transient data	Correct the target station number at the request source, and retry the operation.
D2ABH	Network No. error in transient data	Correct the network number of the request source at the request source, and retry the operation.
D2ACH	Transient data request source No. error	Correct the station number of the request source at the request source, and retry the operation.
D2ADH	Data length error in transient data	Adjust the number of data (frame length) at the request source, and retry the operation.
D2AEH	Target station No. error in transient data	<ul style="list-style-type: none"> <li>• The head module received transient data that is addressed to a different network. Check the network and station numbers, and retry the operation.</li> <li>• Check if the routing parameters are correctly set, and take corrective action.</li> </ul>
D2AFH	Target station No. error in transient data	<ul style="list-style-type: none"> <li>• Transient data transmission addressed to the own station was requested. Check the network number and target station number, and retry the operation.</li> <li>• Check if the routing parameters are correctly set, and take corrective action.</li> </ul>
D2B0H	Transient transmission failed	<ul style="list-style-type: none"> <li>• Check if the cables and switching hub of the request source are connected properly.</li> <li>• Exchange the cables between PORT1 and PORT2 of the request source and retry the operation.</li> <li>• Reduce the frequency of transient transmission and then retry the operation.</li> </ul>
D501H	Communication LSI failure	<ul style="list-style-type: none"> <li>• A malfunction may have occurred due to noise. Check the wire and cable distances and grounding condition of each device, and take measures against noise.</li> <li>• Execute a unit test for the head module. If a failure is detected again, the hardware of the head module may be faulty. Please consult your local Mitsubishi service center or representative, explaining a detailed description of the problem.</li> </ul>
D502H	MAC address error	<ul style="list-style-type: none"> <li>• A malfunction may have occurred due to noise. Check the wire and cable distances and grounding condition of each device, and take measures against noise.</li> <li>• Execute a unit test for the head module. If a failure is detected again, the hardware of the head module may be faulty. Please consult your local Mitsubishi service center or representative, explaining a detailed description of the problem.</li> </ul>
D529H to D52AH	RAM failure	<ul style="list-style-type: none"> <li>• A malfunction may have occurred due to noise. Check the wire and cable distances and grounding condition of each device, and take measures against noise.</li> <li>• Execute a unit test for the head module. If a failure is detected again, the hardware of the head module may be faulty. Please consult your local Mitsubishi service center or representative, explaining a detailed description of the problem.</li> </ul>
D52BH to D52CH	Communication LSI failure	<ul style="list-style-type: none"> <li>• A malfunction may have occurred due to noise. Check the wire and cable distances and grounding condition of each device, and take measures against noise.</li> <li>• Execute a unit test for the head module. If a failure is detected again, the hardware of the head module may be faulty. Please consult your local Mitsubishi service center or representative, explaining a detailed description of the problem.</li> </ul>

Error code	Error	Action
D62Dh	Failed to start data link	<p>The system failed to start data link due to any of the following causes. Remove the cause of the problem, and retry the operation.</p> <ul style="list-style-type: none"> <li>• No station number setting</li> <li>• Head module failure</li> <li>• Master station duplication</li> <li>• Station type mismatch</li> <li>• No master station</li> <li>• Invalid station number of the own station</li> <li>• Duplication of the own station number</li> <li>• Own station specified as reserved station</li> <li>• Parameter error</li> <li>• Parameters being sent</li> <li>• Parameters not received (Only the master station, and no slave stations exist.)</li> <li>• Link stop instruction</li> </ul>
D62Eh	Master station lost	Communication with the master station was lost. Check the wiring for cable disconnection.
D721h	Link start/stop retry error (to another station)	<ul style="list-style-type: none"> <li>• Link stop cannot be performed because cyclic transmission has been stopped.</li> <li>• Link start cannot be performed because cyclic transmission is in execution.</li> </ul>
D722h	Link start/stop retry error (to own station)	<ul style="list-style-type: none"> <li>• Link stop cannot be performed because cyclic transmission has been stopped.</li> <li>• Link start cannot be performed because cyclic transmission is in execution.</li> </ul>
D725h	Station type error (station executing data link start/stop to the entire system)	The head module cannot execute link start/stop of all or multiple stations. Execute link start/stop of all or multiple stations from the master station.
D726h	Transient data request error	Correct the request command at the request source, and retry the operation.
D727h	Data link start/stop instructing station error	<ul style="list-style-type: none"> <li>• Link start was instructed from a station different from the station that instructed the link stop. The station instructing a link start must be the same as the station that instructed the link stop.</li> <li>• The method of the link start (data link start instruction in CC-Link IE Field Network diagnostics or by using the link special relay (SB) or link special register (SW) in the program) is different from that of the link stop. Instruct the link start by the same method as used for the link stop instruction.</li> <li>• Link start has failed in the past. Force the system to restart data link.</li> </ul>
D728h	Data link start/stop instructing station error	Link start was instructed during execution of data link. Instruct link start after instruction of link stop.
D729h	Station No. or network No. not set	<ul style="list-style-type: none"> <li>• Set a station number or a network number and write the parameter using the programming tool.</li> <li>• By online operation of the master station, set the network or station number of the head module.</li> </ul>
D72Ah	Out-of-range station No.	By online operation of the master station, change it to a valid value when setting the network or station number of the head module. Network No.: 1 to 239 Station No.: 1 to 120
D783h to D784h	Transient data request error	<ul style="list-style-type: none"> <li>• The read request by the CC-Link IE Field Network diagnostics of the programming tool is incorrect. Close the "CC IE Field Diagnostics" window, and request it again.</li> <li>• Check the read request data at the request source station, and retry the operation.</li> </ul>

Error code	Error	Action
D800H	Head module failure	<ul style="list-style-type: none"> <li>• A malfunction may have occurred due to noise. Check the wire and cable distances and grounding condition of each device, and take measures against noise.</li> <li>• Execute a unit test for the head module. If a failure is detected again, the hardware of the head module may be faulty. Please consult your local Mitsubishi service center or representative, explaining a detailed description of the problem.</li> </ul>
D806H	Receive queue full	<ul style="list-style-type: none"> <li>• Reduce the frequency of transient transmission and then retry the operation.</li> <li>• Check if the cables and switching hub are connected properly.</li> </ul>
D814H	Head module failure	<ul style="list-style-type: none"> <li>• A malfunction may have occurred due to noise. Check the wire and cable distances and grounding condition of each device, and take measures against noise.</li> <li>• Execute a unit test for the head module. If a failure is detected again, the hardware of the head module may be faulty. Please consult your local Mitsubishi service center or representative, explaining a detailed description of the problem.</li> </ul>
D816H	Head module failure	<ul style="list-style-type: none"> <li>• A malfunction may have occurred due to noise. Check the wire and cable distances and grounding condition of each device, and take measures against noise.</li> <li>• Execute a unit test for the head module. If a failure is detected again, the hardware of the head module may be faulty. Please consult your local Mitsubishi service center or representative, explaining a detailed description of the problem.</li> </ul>
D81AH	Head module stop error	Check the error in the "PLC Diagnostics" window of the programming tool.
D827H	Communication RAM failure	<ul style="list-style-type: none"> <li>• A malfunction may have occurred due to noise. Check the wire and cable distances and grounding condition of each device, and take measures against noise.</li> <li>• Execute a unit test for the head module. If a failure is detected again, the hardware of the head module may be faulty. Please consult your local Mitsubishi service center or representative, explaining a detailed description of the problem.</li> </ul>
D902H	Incorrect online test data	<ul style="list-style-type: none"> <li>• Check the data at the station that initiated the online test, and retry the test.</li> <li>• If this error persists, please consult your local Mitsubishi service center or representative, explaining a detailed description of the problem.</li> </ul>
D903H	Communication test retry error	After completion of the communication test, retry it.
D905H	Communication monitoring time in communication test timed out	<ul style="list-style-type: none"> <li>• Check the network condition by CC-Link IE Field Network diagnostics, take action, and retry the operation.</li> <li>• Check if the routing parameters are correctly set.</li> </ul>
D906H	Transmission completion wait time in communication test timed out	<ul style="list-style-type: none"> <li>• Check the network status using the CC-Link IE Field Network diagnostics of the programming tool, take action, and retry the operation.</li> <li>• Reduce the frequency of transient transmission, and retry the operation.</li> <li>• When the mode of the master station is "Online (High Speed Mode)", change it to "Online (Normal Mode)" and retry the operation.</li> <li>• Check if the routing parameters are correctly set.</li> </ul>
D909H	Header information error in transient data	Correct the header information at the request source, and retry the operation.
D90AH	Double communication test data received	After completion of the communication test, retry it.
D90BH	Incorrect number of stations	<ul style="list-style-type: none"> <li>• Check the network status using the CC-Link IE Field Network diagnostics of the programming tool.</li> <li>• If the number of slave stations per network is more than 120, reduce it to 120 or less.</li> </ul>

Error code	Error	Action
D90CH	Communication target station specification error	Check "Communication Destination Setting" of the communication test, and retry the operation.
D90DH	Cable test retry error	After completion of the cable test, retry it.
DA00H to DA01H	Head module failure	<ul style="list-style-type: none"> <li>• A malfunction may have occurred due to noise. Check the wire and cable distances and grounding condition of each device, and take measures against noise.</li> <li>• Execute a unit test for the head module. If a failure is detected again, the hardware of the head module may be faulty. Please consult your local Mitsubishi service center or representative, explaining a detailed description of the problem.</li> </ul>
DA10H to DA18H	Head module failure	<ul style="list-style-type: none"> <li>• A malfunction may have occurred due to noise. Check the wire and cable distances and grounding condition of each device, and take measures against noise.</li> <li>• Execute a unit test for the head module. If a failure is detected again, the hardware of the head module may be faulty. Please consult your local Mitsubishi service center or representative, explaining a detailed description of the problem.</li> </ul>
DAF2H	Failed to write to flash ROM	<ul style="list-style-type: none"> <li>• If the number of times that data were written to the flash ROM exceeded 100,000, clear the check box in "Communication Head Setting" of PLC Parameter so that data of the error history and system error history will not be held at the time of power off or reset.</li> <li>• Check the wire and cable distances and grounding condition of each device, and take measures against noise.</li> <li>• Execute a unit test for the head module. If a failure is detected again, the hardware of the head module may be faulty. Please consult your local Mitsubishi service center or representative, explaining a detailed description of the problem.</li> </ul>
DAF3H	MAC address read error	<ul style="list-style-type: none"> <li>• The RAM may malfunction due to noise. Check the wire and cable distances and grounding condition of each device, and take measures against noise.</li> <li>• Execute a unit test for the head module. If a failure is detected again, the hardware of the head module may be faulty. Please consult your local Mitsubishi service center or representative, explaining a detailed description of the problem.</li> </ul>

# APPENDICES

## Appendix 1 External Input/Output Forced On/Off

This section describes the function that forcibly turns on or off the external input/output of the head module.

### (1) Input/output operation when a forced on/off operation is performed

Three types of forced on/off operations are available as shown in the following table. The following table shows the status of input (X) and output (Y) when a forced on/off operation is performed.

Operation	Input (X) operation	Output (Y) operation
Forced ON registration	The remote input (RX) assigned to input (X) is transmitted cyclically in a forced on-status.	Regardless of the remote output (RY) that was transmitted cyclically, "ON" is output externally.
Forced OFF registration	The remote input (RX) assigned to input (X) is transmitted cyclically in a forced off-status.	Regardless of the remote output (RY) that was transmitted cyclically, "OFF" is output externally.
Forced on/off clear	The remote input (RX) is changed by an external input.	The remote output (RY) of the master station is output to the external device.

**Ex.** The following shows the input/output operation when a forced on/off operation is performed.

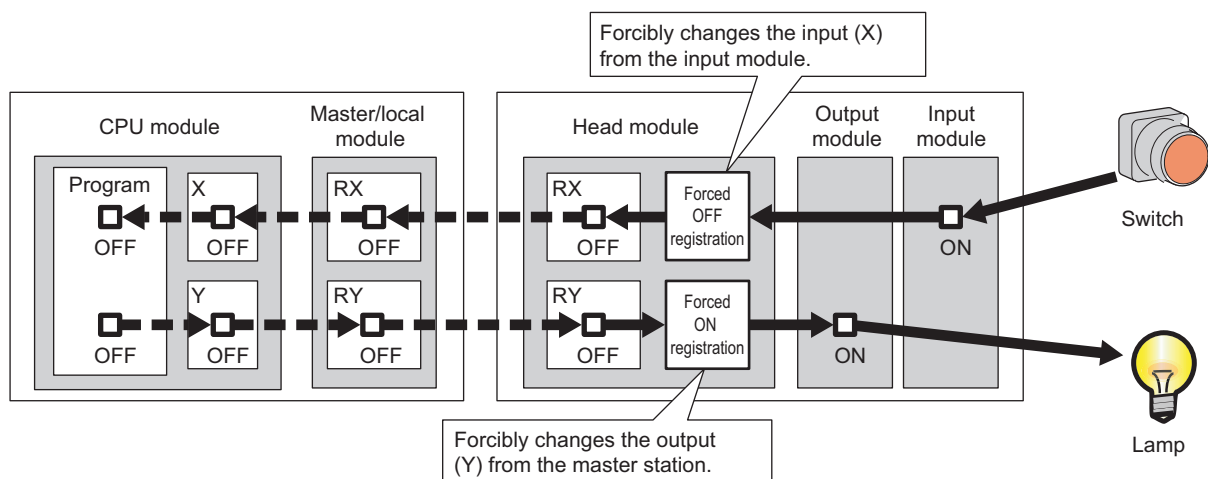



**(a) Number of devices that can be registered**

Up to 32 devices in total can be registered.

**(b) Checking the execution status**

- "Forced Input Output Registration/Cancellation" screen of GX Works2
- Flashing of the MODE LED (green) (The MODE LED flashes in green when a device is registered.)
- The on status of the 0 bit in debug function usage (SD840)

**(c) Forcibly turning on/off from multiple GX Works2**

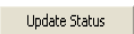
Forced on/off can be registered from multiple GX Works2 to a single head module. In this case, the last registration is effective. For this reason, the GX Works2 that executed the forced on/off may display an on/off information that is different from that of the head module. When the forced on/off registration is performed from multiple GX Works2, click the "  " button to update the data, and then execute the function.

**(d) Status of devices after forced on/off registration data are canceled**

When the on/off registration information of the following input (X) and output (Y) are canceled, the forced on/off status is retained.

- Of the inputs (X) in the range of unattached modules, input (X) that is outside the refresh range with CC-Link
- Output (Y) that is outside the range that was set in "RX/RX Setting" of Network Configuration Setting of the master station

**(e) Status of the Head Module**

The REM. LED of head module flashes.

Forced on/off can be registered regardless of the RUN/STOP status.

If an error occurs in the head module, output (Y) cannot be turned on.

**(f) Target input/output**

- Input/output (X/Y) of the connected modules
- Input/output (X/Y) of the head module that corresponds to the refresh range of the remote I/O (RX/RX) of the connected CC-Link master/local module.

## (2) Operating procedure

1. Open the "Forced Input Output Registration/Cancellation" dialog box.



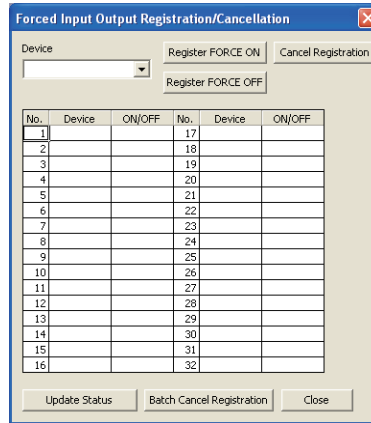

 [Debug] ⇨ [Forced Input Output Registration/Cancellation...]



2. Enter the target device to the "Device" column.

The setting range in the "Device" column is X0 to X1FFF or Y0 to Y1FFF.

3. Click the button for the intended operation.

Button Name	Description	Button Name	Description
	Registers forced on for a specified device.		Cancels forced on/off registered for the device specified.
	Registers forced off for a specified device.		Cancels all forced on/off registrations.

The latest on/off status can be checked by clicking the  button.

## Appendix 2 File Password 32

Both read passwords and write passwords can be set to each file stored in the head module. By this function, files can be protected against tampering and theft by a third-party.

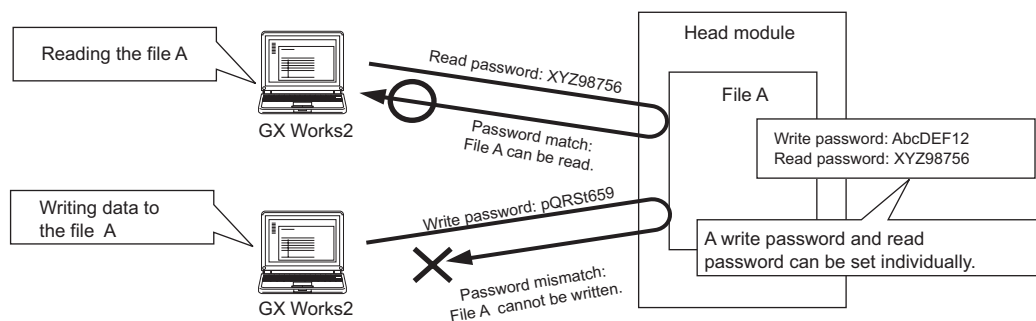

A

## Appendix 2.1 Setting file passwords

---

This section describes the characters which can be used for the password, and the types of files that can be password-protected.

### **Point**

If you forget the password, initialize the head module by formatting the PLC memory in GX Works2, and write the project to the head module from scratch.

---

### **(1) Characters applicable to passwords**

A read password and write password can be set individually. Alternatively, one same password can be specified for both read and write passwords.

- Applicable characters: ASCII characters (numbers, alphabets<sup>\*1</sup>, special characters<sup>\*2</sup>)
- Number of characters applicable: 4 to 32 characters

\*1 Alphabets are case-sensitive.

\*2 Special characters are ` ~ ! @ # \$ % ^ & \* ( ) \_ + - = { } | \ : " ; ' < > ? , . / [ ] , and spaces.

### **(2) Timing for file protection to be enabled/disabled**

Files are protected immediately after registration of a password, and the file protection is disabled immediately after deletion of the password.

### **(3) Files that can be password-protected**

Passwords can be set to parameter files.

### **(4) Online operations that require password authentication**

Password authentication is required for the following operations whenever the file is password-protected.

 Page 118, Appendix 2.2)

- |                                  |   |
|----------------------------------|---|
| • Read from PLC (data reading)   | • Write to PLC (data writing)                                   |
| • Verify with PLC (data reading) |   |
| • Delete PLC Data (data writing) | • Create/Change/Delete of a password (data reading and writing) |

## (5) Creating, changing, deleting, and canceling passwords

### (a) Creating and changing

Open the "Create/Change Password" dialog box.

 [Online] ⇨ [Password/Keyword] ⇨ [New...]

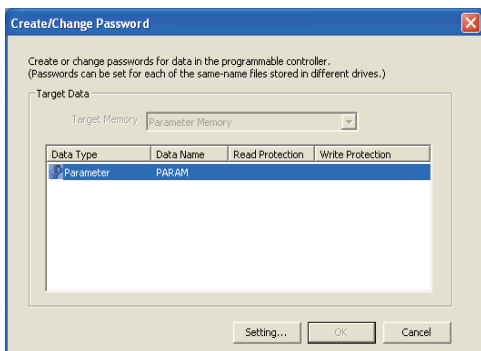

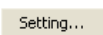
1. Click the  button.

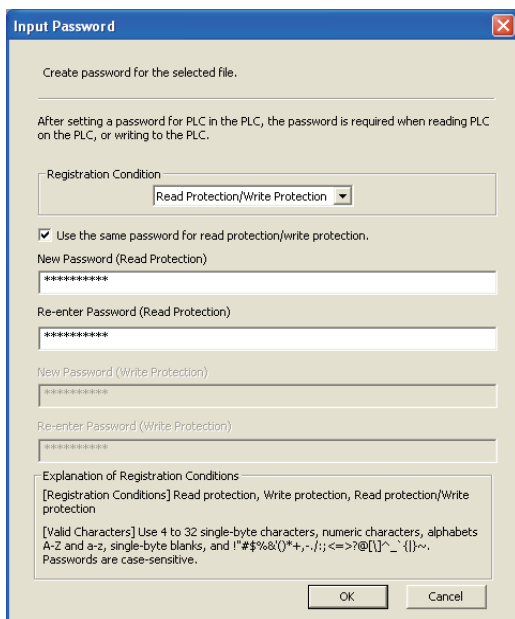

2. Select any of the following values for "Registration Condition".

- Read Protection
- Write Protection
- Read Protection/Write Protection

Enter password (s) and click the  button.

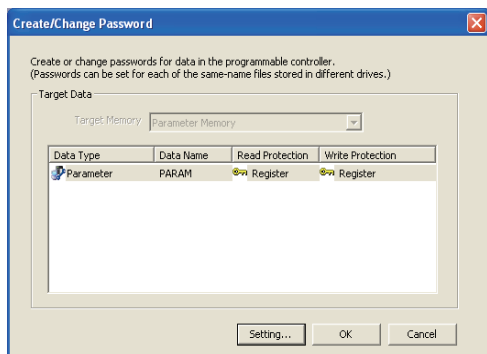

3. The registration status appears as "Register".

Click the  button. The passwords are registered.

A

Appendix 2 File Password 32  
Appendix 2.1 Setting file passwords

## (b) Deleting

Open the "Delete Password" dialog box.

 [Online] ⇨ [Password/Keyword] ⇨ [Delete...]

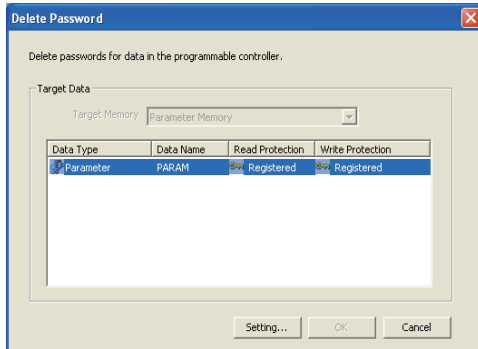

1. Click the **Setting...** button.

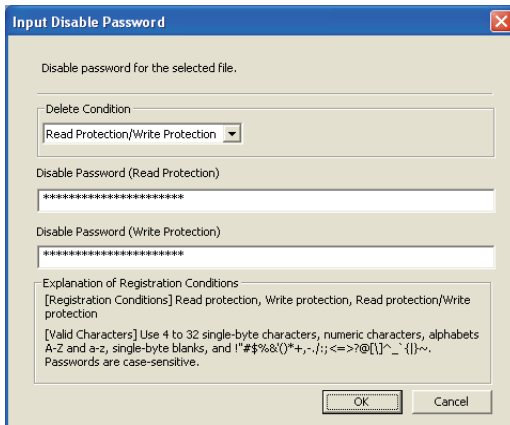

2. Enter password (s) and click the **OK** button.

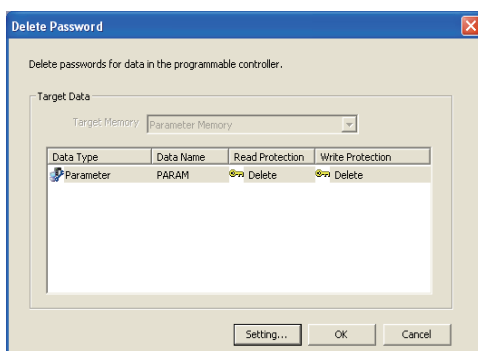

3. The registration status appears as "Deleted".  
Click the **OK** button. The passwords are deleted.

**(c) Disabling**

Open the "Input Disable Password" dialog box.

 [Online] ⇨ [Password/Keyword] ⇨ [Disable]

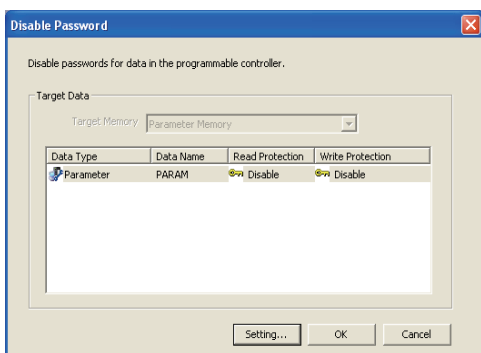
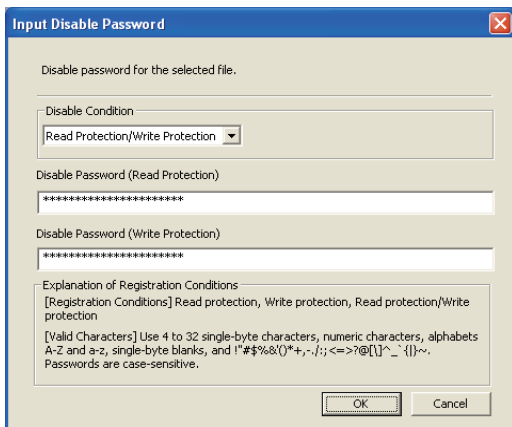
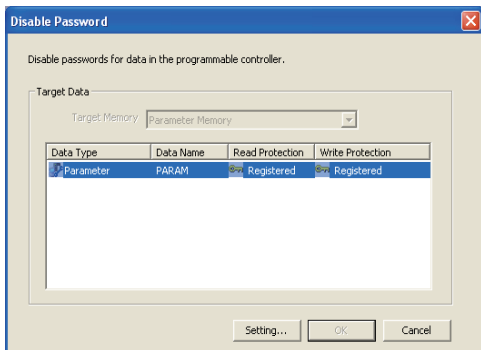

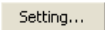
**1. Click the  button.**

**2. Enter password (s) and click the  button.**

**3. The registration status appears as "Disabled". Click the  button. The passwords are disabled.**

**A**

Appendix 2 File Password 32  
 Appendix 2.1 Setting file passwords

## Appendix 2.2 Password authentication

---

The passwords can be authenticated by the following methods.

- By GX Works2
- By the MC protocol

### (1) By GX Works2

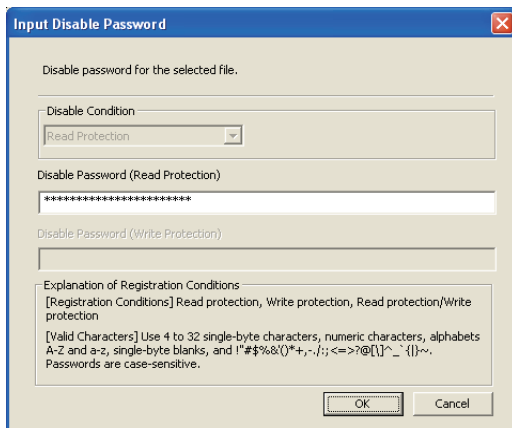
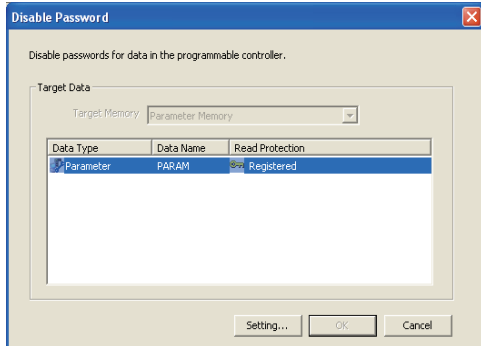

1. Whenever an online operation requiring password authentication is executed, the "Disable Password" dialog box appears.

Click the **Setting...** button.

2. Enter a password in the "Input Disable Password" dialog box.

---

### Point

The entered password is valid until the project is closed.

---



**(2) By the MC protocol**

To access a password-protected file from the outside by using the MC protocol, the request message format of the MC protocol must be changed and a command must be specified for the file password 32.

- 1. Append "Keyword" at the end of the request message, and set a password in that area.**
- 2. Authenticate the password using the password set to "Keyword".**
- 3. For the commands requiring password authentication, specify 0004, subcommand in a request message, as a command for the password 32.**

Function	Command (subcommand)
File delete	1822 (0004)
File attribute change	1825 (0004)
File copy	1824 (0004)
File open	1827 (0004)

For details, refer to the following.

 MELSEC-Q/L MELSEC Communication Protocol Reference Manual

**A**

# Appendix 3 END Cover

This section describes the specifications of the END cover.

For specifications of the END cover with ERR terminal (L6EC-ET), refer to the following.

 MELSEC-L CPU Module User's Manual (Hardware Design, Maintenance and Inspection)

## (1) Part Names

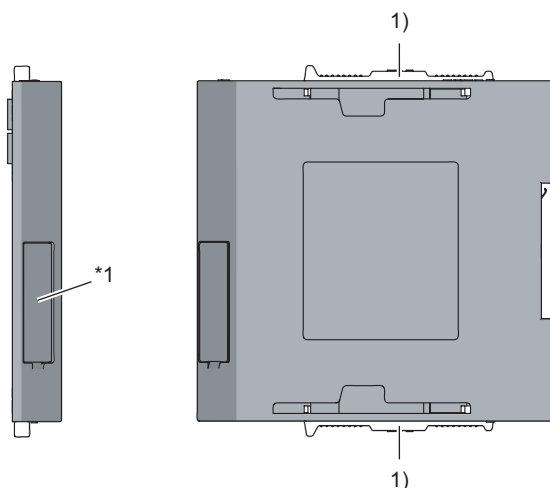

\*1 Do not remove this label as it is for maintenance.

No.	Name	Application
1)	Module joint levers	Levers for connecting modules each other.

## (2) Specifications

Item		L6EC
External dimensions	H	90mm
	W	13mm
	D	95mm
Internal current consumption		0.04A
Weight		0.06kg

## Appendix 4 Link Special Relay (SB) List

The link special relay (SB) is turned ON/OFF depending on various factors occurred in data link. Any error status of the data link can be confirmed by monitoring it.

### (1) Use of the link special relays (SB)

By using the link special relays (SB), the status of the CC-Link IE Field Network can be also checked from an HMI (Human Machine Interface), not only from GX Works2.

### (2) Areas turned on/off by a user and the system

- Area turned on/off by the system: SB0000 to SB0FFF
- Area turned on/off by a user: SB1000 to SB1FFF

### (3) Link special relay (SB) list

The following lists link special relays (SB).

#### *Point*

Do not turn on/off an area whose number is not on the link special relay (SB) list. Doing so may cause malfunction of the programmable controller system.

No.	Name	Description
SB004F	Operating station number status	Stores information on whether the module is operating with the network number and station number set in the "Communication Head Setting" of PLC Parameter, or the module is operating with the numbers set in the CC-Link IE Field Network Diagnostics. OFF: Operating using the values set in "Communication Head Setting" of PLC Parameter ON: Operating using the values set in the CC-Link IE Field Network Diagnostics  This area is also turned ON in the following cases: • There is no parameter in the head module. • The "Network No." and "Station No." fields are left blank in "Communication Head Setting" of PLC Parameter, and no station number has been set from the CC-Link IE Field Network Diagnostics.
SB006A	PORT1 linkup status (own station)	Stores the linkup status of PORT1 (own station). OFF: Linkup in progress ON: Linkdown in progress The time it takes for the linkup to complete after powering ON or connecting the Ethernet cable may fluctuate by a few seconds.
SB006B	PORT2 linkup status (own station)	Stores the linkup status of PORT2 (own station). OFF: Linkup in progress ON: Linkdown in progress The time it takes for the linkup to complete after powering ON or connecting the Ethernet cable may fluctuate by a few seconds.
SB1000 to SB1FFF	For CC-Link master/local modules	By setting this as the refresh destination device of the link special relay (SB) for the CC-Link master/local modules, the data link status of CC-Link can be checked.

# Appendix 5 Link Special Register (SW) List

---

In the link special register (SW), data link information is stored as numerical values. By monitoring it, faulty areas and their causes can be checked.

## (1) Use of the link special registers (SW)

By using the link special relays (SB), the status of the CC-Link IE Field Network can be also checked from an HMI (Human Machine Interface), not only from GX Works2.

## (2) Areas to which data are stored by a user and the system

- Area to which data are stored by the system: SW0000 to SW0FFF
- Area to which data are stored by a user: SW1000 to SW1FFF

## (3) Link special register (SW) list

The following lists link special registers (SW).

### *Point*

---

Do not write any data to an area whose number is not on the link special register (SW) list. Doing so may cause malfunction of the programmable controller system.

---

No.	Name	Description
SW0040	Network No.	Stores the network number of own station. Range: 1 to 239
SW0042	Station No.	Stores the station number of own station. Range: 1 to 120 (slave stations), FFFF <sub>H</sub> (station number not set)
SW0043	Mode status	Stores the mode of own station. 0: Online 2: Offline 9: Unit test
SW0047	Baton pass status (own station)	Stores the communication status of own station. 0: Data link in progress 2: Data link stopped, baton pass in progress 3: Baton pass stopped 5: Offline
SW0048	Cause of baton pass interruption	Stores the cause of interruption in the communication (baton pass) of own station. 00 <sub>H</sub> : In normal communication or at power-on 30 <sub>H</sub> : Cable disconnection 33 <sub>H</sub> : Disconnection or reconnection in progress 40 <sub>H</sub> : Offline mode
SW0049	Cause of data link stop	Stores the cause which stopped the data link of own station. 00 <sub>H</sub> : In normal communication or at power-on 01 <sub>H</sub> : Stop command issued 02 <sub>H</sub> : Monitoring timeout 10 <sub>H</sub> : Parameter not received 11 <sub>H</sub> : Own station No. out of range 12 <sub>H</sub> : Own station specified as reserved 13 <sub>H</sub> : Station No. duplication (own station) 16 <sub>H</sub> : Station No. not set 18 <sub>H</sub> : Parameter error 19 <sub>H</sub> : Parameter communication in progress 1A <sub>H</sub> : Station type mismatch 20 <sub>H</sub> : Error detected
SW004B	Module status (own station)	Stores the head module status of own station. 01 <sub>H</sub> : STOP (Normal) 02 <sub>H</sub> : STOP (Stop error) 03 <sub>H</sub> : STOP (Continuation error) 04 <sub>H</sub> : RUN (Normal) 05 <sub>H</sub> : RUN (Continuation error) 0F <sub>H</sub> : Initial processing
SW004E	Station No. set for diagnostics	Stores the network number set in the CC-Link IE Field Network Diagnostics. 1 to 239: Network No. FFFF <sub>H</sub> : Station number not broadcast
SW004F		Stores the station number set in the CC-Link IE Field Network Diagnostics. 1 to 120: Station No. FFFF <sub>H</sub> : Station number not broadcast

A

No.	Name	Description
SW0064	Connection status (own station)	<p>Stores the connection status of own station.</p> <p>00H: Normal</p> <p>01H: Normal (communication in progress on PORT1, cable disconnected on PORT2)</p> <p>04H: Normal (loopback communication in progress on PORT1, cable disconnected on PORT2)</p> <p>10H: Normal (cable disconnected on PORT1, communication in progress on PORT2)</p> <p>11H: Disconnecting (cables disconnected on PORT1 and PORT2)</p> <p>12H: Disconnecting (cable disconnected on PORT1, establishing line on PORT2)</p> <p>21H: Disconnecting (establishing line on PORT1, cable disconnected on PORT2)</p> <p>22H: Disconnecting (establishing line on PORT1 and PORT2)</p> <p>40H: Normal (cable disconnected on PORT1, loopback communication in progress on PORT2)</p>
SW1000 to SW1FFF	For CC-Link master/local modules	By setting this as the refresh destination device of the link special register (SW) for the CC-Link master/local modules, the data link status of CC-Link can be checked.

## Appendix 6 Special Relay (SM) List

The special relay (SM) is an internal relay whose application is fixed in the programmable controller. However, it can be turned ON/OFF as needed to control the head module.

The following table shows how to read the special relay list.

Item	Description
No.	Special relay number
Name	Special relay name
Description	Contents of special relay
Details	Detailed description of special relay
Set by (Set timing)	Set side and set timing of special relay <Set by> <ul style="list-style-type: none"> <li>• S: Set by system</li> <li>• U: Set by the user (via network or by test operation of GX Works2)</li> <li>• S/U: Set by both system and user</li> </ul> <Set timing> The following shows the set timing when the special relay is set by system. <ul style="list-style-type: none"> <li>• Initial: Set during initial processing (after power-on or reset)</li> <li>• Status change: Set when the operating status is changed.</li> <li>• On error: Set if an error occurs.</li> <li>• Write: Set when data is written to the module.</li> </ul>

### Point

Do not change the value of any special relay set by the system using test operation, etc. Doing so may result in system down or communication failure.

## (1) Diagnostic information

No.	Name	Description	Details	Set by (Set timing)
SM0	Diagnostic error	OFF: No error ON: Error occurs	<ul style="list-style-type: none"> <li>• Turns ON if the diagnostics results in an error.</li> <li>• Stays ON even if the normal state is restored.</li> </ul>	S (On error)
SM1	Self-diagnostic error	OFF: No self-diagnostic error ON: Self-diagnostic error occurs	<ul style="list-style-type: none"> <li>• Turns ON if the self-diagnostics results in an error.</li> <li>• Stays ON even if the normal state is restored.</li> </ul>	
SM5	Common error information	OFF: No common error information ON: Common error information exists	Turns ON if there is any common error information when SM0 turns ON.	
SM16	Individual error information	OFF: No individual error information ON: Individual error information exists	Turns ON if there is any individual error information when SM0 turns ON.	
SM50	Error clear	OFF → ON: Error clear	Clears an error.	U
SM53	AC/DC Down detection	OFF: No AC/DC Down ON: AC/DC Down detected	When using AC power supply modules, this turns ON if a power outage of 10ms or less occurs. This is reset by powering OFF→ON.	S (On error)
			When using DC power supply modules, this turns ON if a power outage of 10ms or less occurs. This is reset by powering OFF→ON.	
SM61	I/O module verify error	OFF: Normal ON: Error occurs	<ul style="list-style-type: none"> <li>• Turns ON if the status of the I/O module when powered ON is different from the registered status.</li> <li>• Stays ON even if the normal state is restored.</li> </ul>	

## (2) System clock/counter

No.	Name	Description	Details	Set by (Set timing)
SM400	Always ON	ON _____ OFF	Always turns ON.	S (Initial)
SM401	Always OFF	ON OFF _____	Always turns OFF.	



**(3) Drive information**

No.	Name	Description	Details	Set by (Set timing)
SM681	Parameter memory writing flag	ON: Write in progress OFF: Write not in progress	Turns ON when writing parameters to the flash ROM, and turns OFF when writing completes.	S (Write)
SM682	Parameter memory overwrite count error flag	ON: Rewrite count reached 100 thousand OFF: Rewrite count less than 100 thousand	Turns ON when the rewrite count of parameters to the flash ROM reaches 100 thousand. (The head module should be changed.)	

**A**

# Appendix 7 Special Register (SD) List

---

The special register (SD) is an internal register whose application is fixed in the programmable controller. However, data can be written to the special register to control the head module as needed. Data is stored in binary format if not specified.

The following table shows how to read the special register list.

Item	Description
No.	Special register number
Name	Special register name
Description	Contents of special register
Details	Detailed description of special register
Set by (Set timing)	Set side and set timing of special register <Set by> <ul style="list-style-type: none"> <li>• S: Set by system</li> <li>• U: Set by the user (via network or by test operation of GX Works2)</li> <li>• S/U: Set by both system and user</li> </ul> <Set timing> The following shows the set timing when the special register is set by system. <ul style="list-style-type: none"> <li>• Initial: Set during initial processing (after power-on or reset)</li> <li>• Status change: Set when the operating status is changed.</li> <li>• On error: Set if an error occurs.</li> <li>• Switch change: Set when the switch has changed.</li> <li>• Write: Set when data is written to the module.</li> </ul>

---

## *Point*

Do not change the value of any special register set by the system using operations such as device test. Doing so may result in system down or communication failure.

---

(1) Diagnostic information

No.	Name	Description	Details	Set by (Set timing)				
SD0	Diagnostic error	Diagnostic error code	<ul style="list-style-type: none"> <li>Stores the error code for the error that occurred during diagnostics.</li> <li>This is the same data as the latest information in error history and system error history.</li> </ul>	S (On error)				
SD1	Clock time of diagnostic error occurrence	Clock time of diagnostic error occurrence	Stores the year (last 2 digits) and month (2 digit BCD code) the SD0 data was updated. b15 to b8 b7 to b0 (Example) January, 2010 Year (0 to 99)   Month (1 to 12) 1001H The clock of the head module synchronizes with the clock of the master station. (Page 27, Section 3.2)					
SD2			Stores the date and hour (2 digit BCD code) the SD0 data was updated. b15 to b8 b7 to b0 (Example) 10 a.m. on 25th Day (1 to 31)   Hour (0 to 23) 2510H The clock of the head module synchronizes with the clock of the master station. (Page 27, Section 3.2)					
SD3			Stores the minute and seconds (2 digit BCD code) the SD0 data was updated. b15 to b8 b7 to b0 (Example) 35 min. 48 sec. Minutes (0 to 59)   Seconds (0 to 59) 3548H The clock of the head module synchronizes with the clock of the master station. (Page 27, Section 3.2)					
SD4	Error information category	Error information category code	<ul style="list-style-type: none"> <li>Stored to common information (SD5 to SD15) and individual information (SD16 to SD26), respectively.</li> <li>Stores the category code that determines what the error information is.</li> </ul> <table border="1" style="margin-left: 40px;"> <tr> <td>b15 to b8</td> <td>b7 to b0</td> </tr> <tr> <td>Individual information category codes</td> <td>Common information category codes</td> </tr> </table> <ul style="list-style-type: none"> <li>The following codes are stored in the common information category code.                             <ul style="list-style-type: none"> <li>•0: None</li> <li>•1: Module No. (Slot No.)</li> <li>•2: File name/drive name</li> <li>•3: Time (Set value)</li> </ul> </li> <li>The following codes are stored in the individual information category code.                             <ul style="list-style-type: none"> <li>•0: None</li> <li>•1: (Empty)</li> <li>•2: File name/drive name</li> <li>•3: Time (Actual measurement value)</li> <li>•4: None</li> <li>•5: Parameter No.</li> <li>•6: None</li> <li>•7: None</li> <li>•8: None</li> <li>•9: Malfunction information</li> <li>•12: File diagnostic information</li> <li>•13: None</li> </ul> </li> </ul>	b15 to b8	b7 to b0	Individual information category codes	Common information category codes	S (On error)
b15 to b8	b7 to b0							
Individual information category codes	Common information category codes							



Appendix 7 Special Register (SD) List

No.	Name	Description	Details	Set by (Set timing)																																																		
SD5	Common error information	Common error information	<ul style="list-style-type: none"> <li>Stores common information corresponding to the error code (SD0).</li> <li>There are three types of information that are stored.</li> <li>The type of error common information can be identified by SD4 "common information category code". (The values of "common information category code" stored in SD4 correspond to items 1) to 3) below.)</li> </ul> <p>1) Module No.</p> <table border="1"> <thead> <tr> <th>Number</th> <th>Meaning</th> </tr> </thead> <tbody> <tr> <td>SD5</td> <td>Slot No. * 1, * 2</td> </tr> <tr> <td>SD6</td> <td>I/O No. *3</td> </tr> <tr> <td>SD7</td> <td rowspan="9">(Empty)</td> </tr> <tr> <td>SD8</td> </tr> <tr> <td>SD9</td> </tr> <tr> <td>SD10</td> </tr> <tr> <td>SD11</td> </tr> <tr> <td>SD12</td> </tr> <tr> <td>SD13</td> </tr> <tr> <td>SD14</td> </tr> <tr> <td>SD15</td> </tr> </tbody> </table> <p>*1The slot number is defined as follows: [Slot No.] This value identifies the connected module. The module connected to the right of the head module is considered "Slot No. = 0", and the rest of the modules are numbered incrementally in series. *2If the slot number does not exist in the module No., FFH is stored. *3When FFFFH is stored in SD6 (I/O No.), it means that the I/O No. could not be identified in I/O Assignment of PLC Parameter. In this case, the error location is identified in SD5.</p> <p>2) File name/drive name</p> <table border="1"> <thead> <tr> <th>Number</th> <th>Meaning</th> </tr> </thead> <tbody> <tr> <td>SD5</td> <td>Drive</td> </tr> <tr> <td>SD6</td> <td rowspan="4">File name (ASCII code: 8 characters)</td> </tr> <tr> <td>SD7</td> </tr> <tr> <td>SD8</td> </tr> <tr> <td>SD9</td> </tr> <tr> <td>SD10</td> <td>Extension *4   2EH(.)</td> </tr> <tr> <td>SD11</td> <td>(ASCII code: 3 characters)</td> </tr> <tr> <td>SD12</td> <td rowspan="4">(Empty)</td> </tr> <tr> <td>SD13</td> </tr> <tr> <td>SD14</td> </tr> <tr> <td>SD15</td> </tr> </tbody> </table> <p>(Example) File name = ABCDEFGHIJ. IJK b15 to b8 b7 to b0 42H(B) 41H(A) 44H(D) 43H(C) 46H(F) 45H(E) 48H(H) 47H(G) 49H(I) 2EH(.) 4BH(K) 4AH(J)</p> <p>3) Time (Set value)</p> <table border="1"> <thead> <tr> <th>Number</th> <th>Meaning</th> </tr> </thead> <tbody> <tr> <td>SD5</td> <td>Time : 1μs units (0 to 999μs)</td> </tr> <tr> <td>SD6</td> <td>Time : 1ms units (0 to 65535ms)</td> </tr> <tr> <td>SD7</td> <td rowspan="9">(Empty)</td> </tr> <tr> <td>SD8</td> </tr> <tr> <td>SD9</td> </tr> <tr> <td>SD10</td> </tr> <tr> <td>SD11</td> </tr> <tr> <td>SD12</td> </tr> <tr> <td>SD13</td> </tr> <tr> <td>SD14</td> </tr> <tr> <td>SD15</td> </tr> </tbody> </table> <p>*4For the names of extensions, refer to the table below on this page.</p>	Number	Meaning	SD5	Slot No. * 1, * 2	SD6	I/O No. *3	SD7	(Empty)	SD8	SD9	SD10	SD11	SD12	SD13	SD14	SD15	Number	Meaning	SD5	Drive	SD6	File name (ASCII code: 8 characters)	SD7	SD8	SD9	SD10	Extension *4   2EH(.)	SD11	(ASCII code: 3 characters)	SD12	(Empty)	SD13	SD14	SD15	Number	Meaning	SD5	Time : 1μs units (0 to 999μs)	SD6	Time : 1ms units (0 to 65535ms)	SD7	(Empty)	SD8	SD9	SD10	SD11	SD12	SD13	SD14	SD15	S (On error)
Number				Meaning																																																		
SD5				Slot No. * 1, * 2																																																		
SD6				I/O No. *3																																																		
SD7				(Empty)																																																		
SD8																																																						
SD9																																																						
SD10																																																						
SD11																																																						
SD12																																																						
SD13																																																						
SD14																																																						
SD15																																																						
Number				Meaning																																																		
SD5				Drive																																																		
SD6	File name (ASCII code: 8 characters)																																																					
SD7																																																						
SD8																																																						
SD9																																																						
SD10	Extension *4   2EH(.)																																																					
SD11	(ASCII code: 3 characters)																																																					
SD12	(Empty)																																																					
SD13																																																						
SD14																																																						
SD15																																																						
Number	Meaning																																																					
SD5	Time : 1μs units (0 to 999μs)																																																					
SD6	Time : 1ms units (0 to 65535ms)																																																					
SD7	(Empty)																																																					
SD8																																																						
SD9																																																						
SD10																																																						
SD11																																																						
SD12																																																						
SD13																																																						
SD14																																																						
SD15																																																						

\*4 The names of the extensions are shown in the table below.

SD <sub>n</sub>	SD <sub>n+1</sub>		Extension Name	File Type
	Upper 8 bits	Lower 8 bits		
51H	50H	41H	QPA	Parameter
51H	44H	49H	QDI	Initial device value

No.	Name	Description	Details	Set by (Set timing)																																																																					
SD16	Individual error information	Individual error information	<ul style="list-style-type: none"> <li>Stores individual information corresponding to the error code (SD0).</li> <li>There are six types of information that are stored.</li> <li>The type of error individual information can be identified by SD4 "individual information category code". (The values of "individual information category code" stored in SD4 correspond to items 1) to 6) below.)</li> </ul> <p>1) (Empty)</p> <p>2) File name/drive name</p> <table border="1"> <tr> <td>Number</td> <td>Meaning</td> <td colspan="2">(Example) File name =</td> </tr> <tr> <td>SD16</td> <td>Drive</td> <td>ABCDEF GH. IJK</td> <td></td> </tr> <tr> <td>SD17</td> <td rowspan="2">File name (ASCII code: 8 characters)</td> <td>b15 to b8 b7 to b0</td> <td></td> </tr> <tr> <td>SD18</td> <td>42H(B)</td> <td>41H(A)</td> </tr> <tr> <td>SD19</td> <td></td> <td>44H(D)</td> <td>43H(C)</td> </tr> <tr> <td>SD20</td> <td></td> <td>46H(F)</td> <td>45H(E)</td> </tr> <tr> <td>SD21</td> <td>Extension *4</td> <td>2EH(.)</td> <td>48H(H)</td> <td>47H(G)</td> </tr> <tr> <td>SD22</td> <td>(ASCII code: 3 characters)</td> <td></td> <td>49H(I)</td> <td>2EH(.)</td> </tr> <tr> <td>SD23</td> <td></td> <td></td> <td>4B(H)</td> <td>4A(H)</td> </tr> <tr> <td>SD24</td> <td></td> <td>(Empty)</td> <td></td> <td></td> </tr> <tr> <td>SD25</td> <td></td> <td></td> <td></td> <td></td> </tr> <tr> <td>SD26</td> <td></td> <td></td> <td></td> <td></td> </tr> </table> <p>3) Time (Actual measurement value)</p> <table border="1"> <tr> <td>Number</td> <td>Meaning</td> </tr> <tr> <td>SD16</td> <td>Time : 1 <math>\mu</math>s units (0 to 999 <math>\mu</math>s)</td> </tr> <tr> <td>SD17</td> <td>Time : 1ms units (0 to 65535ms)</td> </tr> <tr> <td>SD18</td> <td rowspan="10">(Empty)</td> </tr> <tr> <td>SD19</td> </tr> <tr> <td>SD20</td> </tr> <tr> <td>SD21</td> </tr> <tr> <td>SD22</td> </tr> <tr> <td>SD23</td> </tr> <tr> <td>SD24</td> </tr> <tr> <td>SD25</td> </tr> <tr> <td>SD26</td> </tr> </table> <p>*4 For names of extensions, refer to the table on Page 130.</p> <p>(To the next page)</p>	Number	Meaning	(Example) File name =		SD16	Drive	ABCDEF GH. IJK		SD17	File name (ASCII code: 8 characters)	b15 to b8 b7 to b0		SD18	42H(B)	41H(A)	SD19		44H(D)	43H(C)	SD20		46H(F)	45H(E)	SD21	Extension *4	2EH(.)	48H(H)	47H(G)	SD22	(ASCII code: 3 characters)		49H(I)	2EH(.)	SD23			4B(H)	4A(H)	SD24		(Empty)			SD25					SD26					Number	Meaning	SD16	Time : 1 $\mu$ s units (0 to 999 $\mu$ s)	SD17	Time : 1ms units (0 to 65535ms)	SD18	(Empty)	SD19	SD20	SD21	SD22	SD23	SD24	SD25	SD26	S (On error)
Number				Meaning	(Example) File name =																																																																				
SD16				Drive	ABCDEF GH. IJK																																																																				
SD17				File name (ASCII code: 8 characters)	b15 to b8 b7 to b0																																																																				
SD18					42H(B)	41H(A)																																																																			
SD19					44H(D)	43H(C)																																																																			
SD20					46H(F)	45H(E)																																																																			
SD21				Extension *4	2EH(.)	48H(H)	47H(G)																																																																		
SD22				(ASCII code: 3 characters)		49H(I)	2EH(.)																																																																		
SD23						4B(H)	4A(H)																																																																		
SD24					(Empty)																																																																				
SD25																																																																									
SD26																																																																									
Number	Meaning																																																																								
SD16	Time : 1 $\mu$ s units (0 to 999 $\mu$ s)																																																																								
SD17	Time : 1ms units (0 to 65535ms)																																																																								
SD18	(Empty)																																																																								
SD19																																																																									
SD20																																																																									
SD21																																																																									
SD22																																																																									
SD23																																																																									
SD24																																																																									
SD25																																																																									
SD26																																																																									



No.	Name	Description	Details	Set by (Set timing)																							
SD26	Individual error information	Individual error information	<p>4) Parameter No.</p> <table border="1"> <thead> <tr> <th>Number</th> <th>Meaning</th> </tr> </thead> <tbody> <tr> <td>SD16</td> <td>Parameter No. *5</td> </tr> <tr> <td>SD17</td> <td rowspan="11">(Empty)</td> </tr> <tr> <td>SD18</td> </tr> <tr> <td>SD19</td> </tr> <tr> <td>SD20</td> </tr> <tr> <td>SD21</td> </tr> <tr> <td>SD22</td> </tr> <tr> <td>SD23</td> </tr> <tr> <td>SD24</td> </tr> <tr> <td>SD25</td> </tr> <tr> <td>SD26</td> </tr> </tbody> </table> <p>*5 For details on parameter No., refer to the following.   Page 51, CHAPTER 7</p>	Number	Meaning	SD16	Parameter No. *5	SD17	(Empty)	SD18	SD19	SD20	SD21	SD22	SD23	SD24	SD25	SD26	S (On error)								
			Number	Meaning																							
			SD16	Parameter No. *5																							
SD17	(Empty)																										
SD18																											
SD19																											
SD20																											
SD21																											
SD22																											
SD23																											
SD24																											
SD25																											
SD26																											
<p>5) Malfunction information</p> <table border="1"> <thead> <tr> <th>Number</th> <th>Meaning</th> </tr> </thead> <tbody> <tr> <td>SD16</td> <td>Failure information 1</td> </tr> <tr> <td>SD17</td> <td>Failure information 2</td> </tr> <tr> <td>SD18</td> <td>Failure information 3</td> </tr> <tr> <td>SD19</td> <td>Failure information 4</td> </tr> <tr> <td>SD20</td> <td>Failure information 5</td> </tr> <tr> <td>SD21</td> <td>Failure information 6</td> </tr> <tr> <td>SD22</td> <td>Failure information 7</td> </tr> <tr> <td>SD23</td> <td>Failure information 8</td> </tr> <tr> <td>SD24</td> <td>Failure information 9</td> </tr> <tr> <td>SD25</td> <td>Failure information 10</td> </tr> <tr> <td>SD26</td> <td>Failure information 11</td> </tr> </tbody> </table>		Number	Meaning	SD16	Failure information 1	SD17	Failure information 2	SD18	Failure information 3	SD19	Failure information 4	SD20	Failure information 5	SD21	Failure information 6	SD22	Failure information 7	SD23	Failure information 8	SD24	Failure information 9	SD25	Failure information 10	SD26	Failure information 11		
Number	Meaning																										
SD16	Failure information 1																										
SD17	Failure information 2																										
SD18	Failure information 3																										
SD19	Failure information 4																										
SD20	Failure information 5																										
SD21	Failure information 6																										
SD22	Failure information 7																										
SD23	Failure information 8																										
SD24	Failure information 9																										
SD25	Failure information 10																										
SD26	Failure information 11																										
<p>6) File diagnostic information</p> <table border="1"> <tbody> <tr> <td>SD16</td> <td>Failure information (H)</td> <td>drive No.(L)</td> </tr> <tr> <td>SD17</td> <td colspan="2" rowspan="4">File name (ASCII: 8 characters)</td> </tr> <tr> <td>SD18</td> </tr> <tr> <td>SD19</td> </tr> <tr> <td>SD20</td> </tr> <tr> <td>SD21</td> <td>EXtension *4</td> <td>2EH(.)</td> </tr> <tr> <td>SD22</td> <td colspan="2">(ASCII; 3 characters)</td> </tr> <tr> <td>SD23</td> <td colspan="2">Failure information 2</td> </tr> <tr> <td>SD24</td> <td colspan="2">(CRC value that is read)</td> </tr> <tr> <td>SD25</td> <td colspan="2">Failure information 3</td> </tr> <tr> <td>SD26</td> <td colspan="2">(CRC value that is calculated)</td> </tr> </tbody> </table> <p>*4 For names of extensions, refer to the table on Page 130.</p>	SD16	Failure information (H)	drive No.(L)	SD17	File name (ASCII: 8 characters)		SD18	SD19	SD20	SD21	EXtension *4	2EH(.)	SD22	(ASCII; 3 characters)		SD23	Failure information 2		SD24	(CRC value that is read)		SD25	Failure information 3		SD26	(CRC value that is calculated)	
SD16	Failure information (H)	drive No.(L)																									
SD17	File name (ASCII: 8 characters)																										
SD18																											
SD19																											
SD20																											
SD21	EXtension *4	2EH(.)																									
SD22	(ASCII; 3 characters)																										
SD23	Failure information 2																										
SD24	(CRC value that is read)																										
SD25	Failure information 3																										
SD26	(CRC value that is calculated)																										
SD50	Error clear	Error code to clear	Stores the error code to clear.	U																							
SD53	AC/DC Down detection	AC/DC Down detection count	<ul style="list-style-type: none"> <li>Each time the input voltage of the head module drops below 85% (AC power)/65% (DC power) of the rated voltage, the value is incremented by 1 and is stored.</li> <li>The counter repeats increment and decrement of the value: 0 → 32767 → -32768 → 0.</li> </ul>	S (On error)																							
SD61	I/O module verify error number	I/O module verify error module number	Stores the lowest I/O No. of the module in which the I/O module verify error occurred.																								

(2) System information

No.	Name	Description	Details	Set by (Set timing)
SD200	Status of switch	Head module switch status	Stores the switch status of the head module. 0: RUN 1: STOP/RESET	S (Switch change)
SD201	LED status	Head-LED status	<ul style="list-style-type: none"> <li>Stores one of the following statuses for the LED of the head module in the following bit pattern.</li> <li>0 = Off, 1 = On, 2 = Flashing</li> </ul> <p>1): REM., 2): ERR., 3): D LINK, 4): Empty, 5): RD, 6): SD, 7): MODE, 8): RUN (While offline, RD and SD are always OFF.)</p>	S (Status change)
SD203	Operating status	Operating status	<p>Stores the operating status of the head module.</p> <p>1) Operating status 0: RUN, 2: STOP 2) Cause of STOP Stores the latest cause of the change in the operating status. 0: STOP switch 1: Master station STOP 2: Remote operation from GX Works2, etc. 4: Error 3) Empty</p>	S (Status change)
SD220	LED display data	LED display data	Stores the ASCII data (16 characters) of the HMI.	S (On change)
SD221				
SD222				
SD223				
SD224				
SD225				
SD226				
SD227				
SD250	Loaded maximum I/O	Loaded maximum I/O number	Stores the upper 2 digits of the last I/O number of the connected module + 1.	S (Initial)



Appendix 7 Special Register (SD) List

No.	Name	Description	Details	Set by (Set timing)
SD286	Device assignment	Number of points assigned for M (For extension)	This register stores the number of M (for extension) points (fixed to 0).	S (Initial)
SD287				
SD288		Number of points assigned for B (For extension)	This register stores the number of B (for extension) points (fixed to 0).	
SD289				
SD290	Device assignment 1	Number of points assigned for X	This register stores the number of X points (fixed to 8192).	
SD291		Number of points assigned for Y	This register stores the number of Y points (fixed to 8192).	
SD292		Number of points assigned for M	This register stores the number of M points (fixed to 0).	
SD293		Number of points assigned for L	This register stores the number of L points (fixed to 0).	
SD294		Number of points assigned for B	This register stores the number of B points (fixed to 0).	
SD295		Number of points assigned for F	This register stores the number of F points (fixed to 0).	
SD296		Number of points assigned for SB	This register stores the number of SB points (fixed to 8192).	
SD297		Number of points assigned for V	This register stores the number of V points (fixed to 0).	
SD298		Number of points assigned for S	This register stores the number of S points (fixed to 0).	
SD299		Number of points assigned for T	This register stores the number of T points (fixed to 0).	
SD300		Number of points assigned for ST	This register stores the number of ST points (fixed to 0).	
SD301		Number of points assigned for C	This register stores the number of C points (fixed to 0).	
SD302		Number of points assigned for D	This register stores the number of D points (fixed to 0).	
SD303		Number of points assigned for W	This register stores the number of W points (fixed to 8192).	
SD304		Number of points assigned for SW	This register stores the number of SW points (fixed to 8192).	
SD305		Device assignment 1 (Index register)	16-bit modification Number of points assigned for Z	This register stores the number of Z points (fixed to 0).
SD306	Device assignment 1	Number of points assigned for ZR (Extension)	This register stores the number of ZR (for extension) points (fixed to 0).	
SD307				
SD308	Device assignment 2 (Assignment including the number of points set to the extended data register (D) and extended link register (W))	Number of points assigned for D (Inside and extension)	This register stores the number of D points (including extended data register) (fixed to 0).	
SD309				
SD310				
SD311		Number of points assigned for W (Inside and extension)	This register stores the number of W points (including extended link register) (fixed to 8192).	



### (3) Drive information

No.	Name	Description	Details	Set by (Set timing)
SD681	Parameter memory write (transfer) status	Write (transfer) status display (percent)	Stores the progress of writing (transferring) to the parameter memory (flash ROM) in percentage (0 to 100%). "0" is set when the write (transfer) command is issued.	S (Write)
SD682 SD683	Parameter memory write count index	Write count index up to the present	Stores the index value of write count of the program memory (flash ROM) <sup>*1</sup> up to the present in 32-bit binary. When the index value exceeds 100 thousand times, "FLASH ROM ERROR" (error code: 1610) occurs. (The index value will continue to be counted even after it exceeds 100 thousand.)  <sup>*1</sup> The write count is not equal to the index value. (Since the maximum write count of the flash ROM has been increased by the system, the value increments by 1 about every two write operations.)	

### (4) Debug

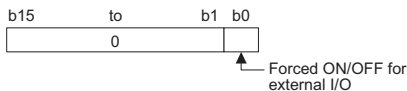
No.	Name	Description	Details	Set by (Set timing)
SD840	Debug function usage	Debug function usage status	Stores the usage status of the following debug functions. 0: External input/output forced ON/OFF function 1 to 15: Empty (fixed at 0)   (0: Not used 1: Used)	S (Status change)

### (5) I/O module verification

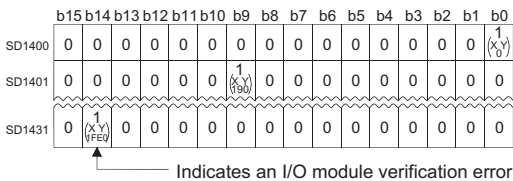
No.	Name	Description	Details	Set by (Set timing)
SD1400 SD1401 SD1402 SD1403 SD1404 SD1405 SD1406 SD1407 SD1408 SD1409 to SD1430 SD1431	I/O module verify error	Bit pattern, in units of 16 points, indicating the modules with verification errors 0: No I/O verification errors 1: I/O verification error exists	<ul style="list-style-type: none"> <li>If the status of the I/O module changes from that obtained at power-on, the module No. is stored in the following bit pattern. (If the I/O numbers are set by parameter, the parameter-set numbers are stored.)</li> </ul>  <ul style="list-style-type: none"> <li>When the number of I/O points of the module exceeds 16 points, all bits corresponding to the I/O module number (in units of 16 points) that is included in the number of I/O points occupied by the module turn on.</li> </ul> <p><b>Ex.</b> When a 64-point module is connected on the slot 0, b0 to b3 are turned on by error detection. <ul style="list-style-type: none"> <li>Not cleared even if the normal state is restored. This flag is cleared by the error resetting operation.</li> </ul> </p>	S (On error)



# Appendix 8 Access and Attribute Codes

---

This section shows the access and attribute codes that are set when accessing the head module with the RIRD or RIWT instruction of the master/local module.

Device <sup>*1</sup>	Name	Device type		Unit	Access code	Attribute code
		Bit	Word			
Input	X	○		Hexadecimal	01H	05H
Output	Y	○		Hexadecimal	02H	
Link register	W		○	Hexadecimal	24H	
Link special relay	SB	○		Hexadecimal	63H	
Link special register	SW		○	Hexadecimal	64H	
Special relay	SM	○		Hexadecimal	43H	
Special register	SD		○	Hexadecimal	44H	

\*1 Devices other than the above cannot be accessed.  
 To access a bit device, specify 0 or a multiple of 16.

## Appendix 9 EMC and Low Voltage Directives

Compliance to the EMC Directive, which is one of the EU Directives, has been a legal obligation for the products sold in European countries since 1996 as well as the Low Voltage Directive since 1997.

Manufacturers who recognize their products are compliant to the EMC and Low Voltage Directives are required to attach a "CE mark" on their products.

### (1) Authorized representative in Europe

Authorized representative in Europe is shown below.

Name: Mitsubishi Electric Europe BV

Address: Gothaer Strasse 8, 40880 Ratingen, Germany

A

## Appendix 9.1 Requirements for Compliance with the EMC Directive

The EMC Directive specifies that "products placed on the market must be so constructed that they do not cause excessive electromagnetic interference (emissions) and are not unduly affected by electromagnetic interference (immunity)". This section summarizes the precautions on compliance with the EMC Directive of the machinery constructed with the MELSEC-L series modules.

These precautions are based on the requirements and the standards of the regulation, however, it does not guarantee that the entire machinery constructed according to the descriptions will comply with above-mentioned directives.

The method and judgement for complying with the EMC Directive must be determined by the person who constructs the entire machinery.

### (1) Standards relevant to the EMC Directive

#### (a) Regulations regarding emission

Specification	Test item	Test details	Standard value
EN61131-2: 2007	CISPR16-2-3 Radiated emission*2	Radio waves from the product are measured.	30M-230MHz QP: 40dB $\mu$ V/m (10m in measurement range)*1 230M-1000MHz QP: 47dB $\mu$ V/m (10m in measurement range)
	CISPR16-2-1, CISPR16-1-2 Conducted emission*2	Noise from the product to the power line is measured.	150k-500kHz QP: 79dB, Mean: 66dB*1 500k-30MHz QP: 73dB, Mean: 60dB

\*1 QP: Quasi-peak value, Mean: Average value

\*2 Programmable controllers are open-type devices (devices designed to be housed inside other equipment) and must be installed inside a conductive control panel. The tests were conducted with the programmable controller installed in a control panel, applying the maximum applicable input voltage to the power supply module.

## (b) Regulations regarding immunity

Specification	Test item	Test details	Standard value
EN61131-2: 2007	EN61000-4-2 Electrostatic discharge immunity <sup>*1</sup>	Immunity test in which electrostatic is applied to the cabinet of the equipment.	<ul style="list-style-type: none"> <li>• 8kV Air discharge</li> <li>• 4kV Contact discharge</li> </ul>
	EN61000-4-3 Radiated, radio-frequency, electromagnetic field immunity <sup>*1</sup>	Immunity test in which electric fields are irradiated to the product.	80% AM modulation@1kHz <ul style="list-style-type: none"> <li>• 80M-1000MHz: 10V/m</li> <li>• 1.4G-2.0GHz: 3V/m</li> <li>• 2.0G-2.7GHz: 1V/m</li> </ul>
	EN61000-4-4 Electrical fast transient/burst immunity <sup>*1</sup>	Immunity test in which burst noise is applied to the power line and signal line.	<ul style="list-style-type: none"> <li>• AC/DC main power, I/O power, AC I/O (unshielded): 2kV</li> <li>• DC I/O, analog, communication: 1kV</li> </ul>
	EN61000-4-5 Surge immunity <sup>*1</sup>	Immunity test in which lightning surge is applied to the power line and signal line.	<ul style="list-style-type: none"> <li>• AC power line, AC I/O power, AC I/O (unshielded): 2kV CM, 1kV DM</li> <li>• DC power line, DC I/O power: 0.5kV CM, DM</li> <li>• DC I/O, AC I/O (shielded), analog<sup>*2</sup>, communication: 1kV CM</li> </ul>
	EN61000-4-6 Immunity to conducted disturbances, induced by radio-frequency fields <sup>*1</sup>	Immunity test in which high frequency noise is applied to the power line and signal line	0.15M-80MHz, 80% AM modulation @1kHz, 10Vrms
	EN61000-4-8 Power-frequency magnetic field immunity <sup>*1</sup>	Immunity test in which the product is installed in inductive magnetic field	50Hz/60Hz, 30A/m
	EN61000-4-11 Voltage dips and interruption immunity <sup>*1</sup>	Immunity test in which power supply voltage is momentarily interrupted	<ul style="list-style-type: none"> <li>• Apply at 0%, 0.5 cycles and zero-cross point</li> <li>• 0%, 250/300 cycles (50/60Hz)</li> <li>• 40%, 10/12 cycles (50/60Hz)</li> <li>• 70%, 25/30 cycles (50/60Hz)</li> </ul>

\*1 Programmable controllers are open-type devices (devices designed to be housed inside other equipment) and must be installed inside a conductive control panel. The tests were conducted with the programmable controller installed in a control panel.

\*2 The accuracy of an analog-digital converter module may temporary vary within  $\pm 10\%$ .

## (2) Installation inside a control panel

The programmable controllers are open type devices and must be installed inside a control panel. <sup>\*1</sup>

This ensures safety as well as effective shielding of programmable controller-generated electromagnetic noise.

\*1 Modules on the remote station in each network must be also installed inside the control panel. However, the waterproof type remote station can be installed outside the control panel.

**(a) Control panel**

- Use a conductive control panel.
- When securing the top or bottom plate using bolts, cover the grounding part on the control panel so that the part will not be painted.
- To ensure electrical contact between the inner plate and control panel, take measures such as covering the bolts so that conductivity can be ensured in the largest possible area.
- Ground the control panel with a thick ground cable so that low impedance can be ensured even at high frequencies.
- Holes in the control panel must be 10cm diameter or less. If the holes are larger than 10cm, radio wave may be emitted. In addition, because radio waves leak through a clearance between the control panel and its door, reduce the clearance as much as possible. The leakage of radio waves can be suppressed by the direct application of an EMI gasket on the paint surface.

Our tests have been carried out on a panel having the attenuation characteristics of 37 dB (max.) and 30 dB (mean) (measured by 3m method, 30 to 300MHz).

**(b) Wiring of power cables and ground cables**

- Provide a ground point near the power supply module. Ground the LG and FG terminals of the power supply module with the thickest and shortest ground cable (30cm or shorter) possible.

**(3) Cables for the CC-Link IE Field Network**

Note the following when using cables for the CC-Link IE Field Network.

- Be sure to use the cables for the CC-Link IE Field Network (SC-E5EW-S□M, manufactured by Mitsubishi Electric System & Service Co., Ltd.).
- Shielded cables should be used for the CC-Link IE Field Network. Strip a part of the jacket as shown below and ground the exposed shield in the largest possible area.

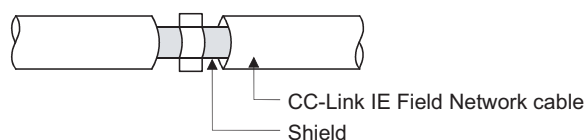

- Use shielded cables for external wiring and ground the shields of the external wiring cables to the control panel with the AD75CK-type cable clamp (Mitsubishi). (Ground the shield of the CC-Link IE Field Network cable 20cm to 30cm away from the module.)

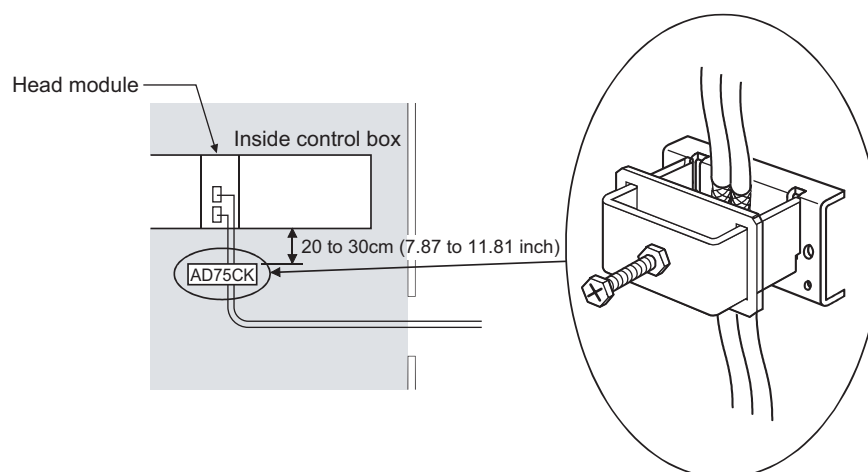

#### (4) Cables used for the modules connected to the head module

Use shielded cables for the cables which are connected to the I/O modules and may be extended out of the control panel.

If a shielded cable is not used or not grounded correctly, the noise immunity will not meet the specified value.

##### (a) Grounding the shield of the shielded cable

- Ground the shield of the shielded cable as close to the module as possible so that the grounded cable will not be affected by electromagnetic induction from ungrounded cables.
- Ground the exposed shield section to large area on the control panel. A clamp fitting can be used as shown in below. In this case, apply a cover on the painted inner wall surface of the control panel, which comes in contact with the fitting.

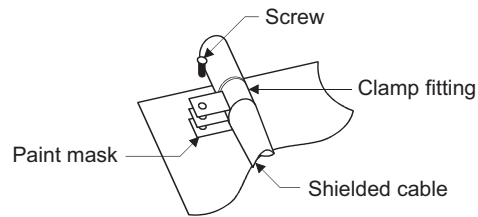

##### **Point**

- Grounding with a vinyl-coated wire soldered onto the shielded section of the shielded cable as shown below is not recommended. Doing so will raise the high-frequency impedance, resulting in loss of the shielding effect.

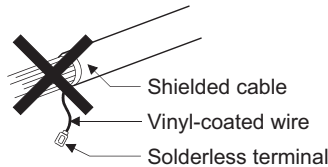

##### (b) Grounding the twisted pair cable

- Always use shielded twisted pair cables for connection to 10BASE-T and 100BASE-TX connectors. For the shielded twisted pair cable, strip a part of the jacket as shown below and ground the exposed shield section to the ground as much as possible.

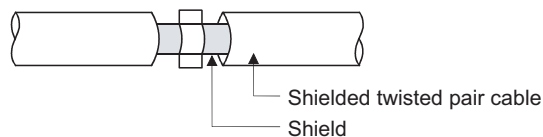

**(c) Grounding the CC-Link Ver. 1.10 compatible cable**

Be sure to ground the cable shield that is connected to the CC-Link module close to the exit of control panel or to any of the CC-Link stations within 30cm from the module or stations.  
 The CC-Link Ver. 1.10 compatible cable is a shielded cable. Strip a part of the jacket as shown below and ground the exposed shield section to the ground as much as possible.

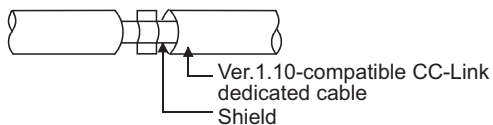

Always use the specified CC-Link Ver. 1.10 compatible cable.

Connect the CC-Link module and the CC-Link stations to the FG line inside the control panel at the FG terminal as shown below.

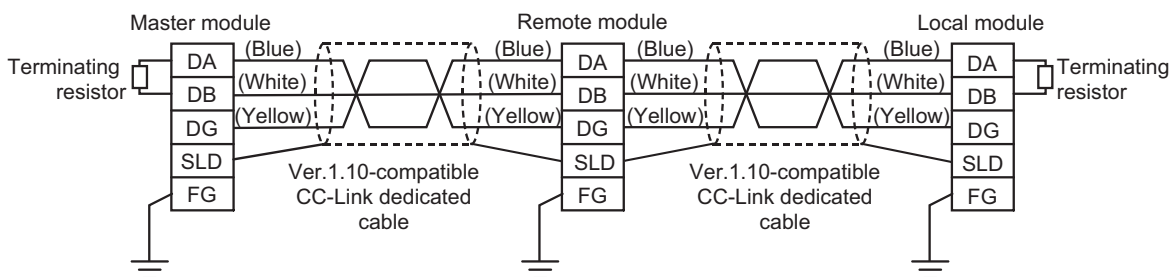

**(d) Grounding the cable clamp**

Use shielded cables for external wiring and ground the shields of the external wiring cables to the control panel with the AD75CK-type cable clamping (Mitsubishi). (Ground the shield section 20 to 30cm away from the module.)

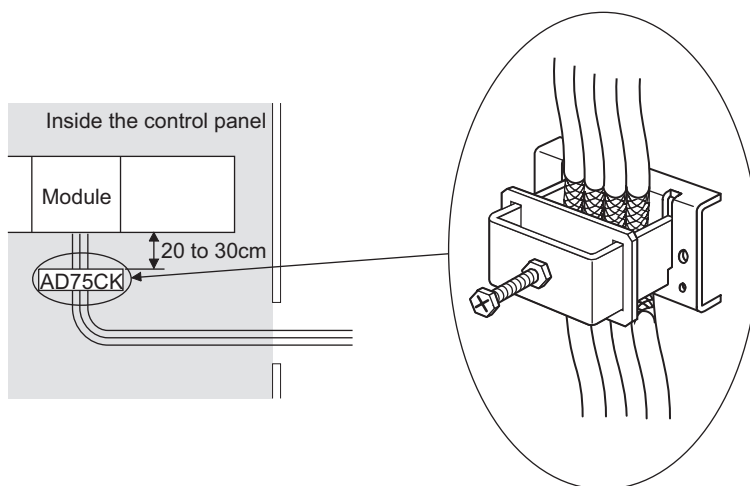

For details of the AD75CK, refer to the following.

AD75CK-type Cable Clamping Instruction Manual

**A**

Appendix 9 EMC and Low Voltage Directives  
 Appendix 9.1 Requirements for Compliance with the EMC Directive

### (e) Connectors for external devices

When using connectors for external devices with any of the following modules, take the noise reduction measures described below.

- High-speed counter module
- Positioning module

[Wiring example when using shielded cables]

The following figure shows the example of wiring using A6CON1 for noise reduction.

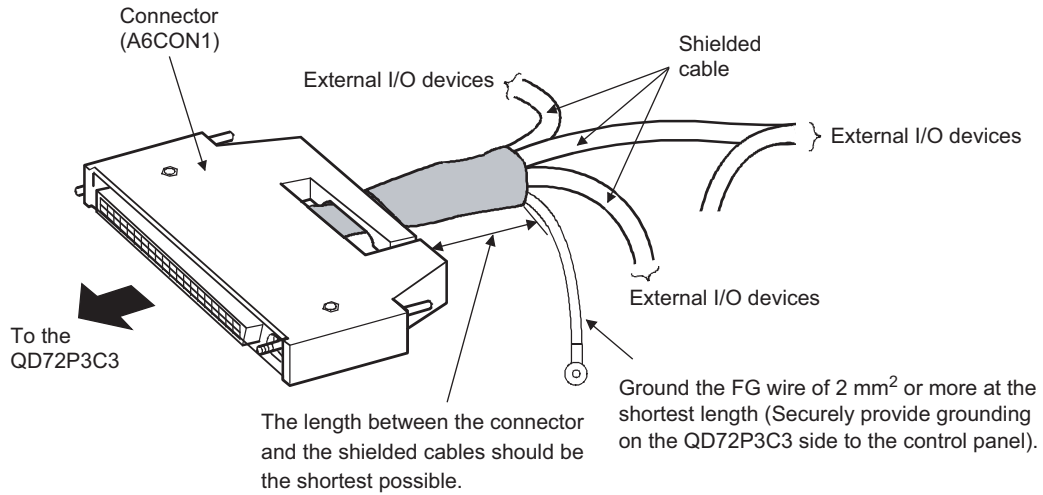

[Example of processing for a shielded cable]

To protect the wires, cover the connector pins with the heat shrinkable insulation tubes.  
(Exposing the wires may cause a malfunction by the affect of static electricity.)

Take off the insulating tube of each shield and electrically connect the shields of the cables with conductive tapes.

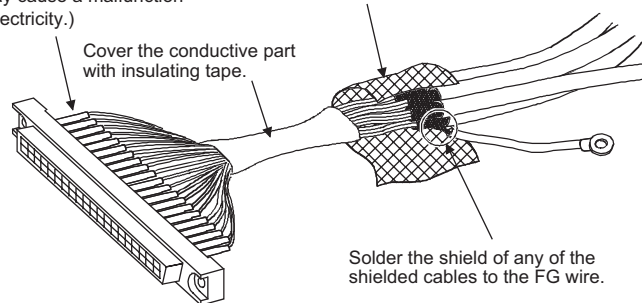



[Wiring example when using a duct (Example of a problem and its solution)]

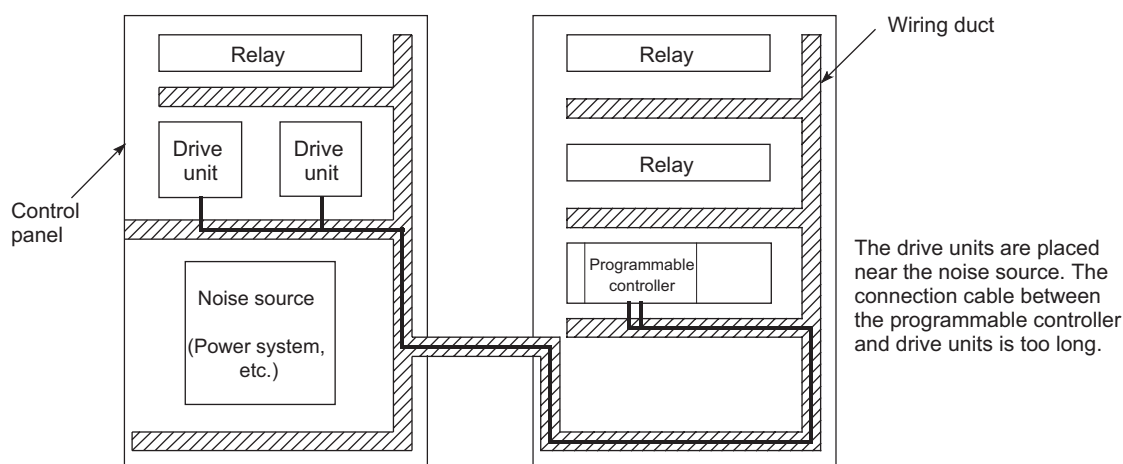

Modified

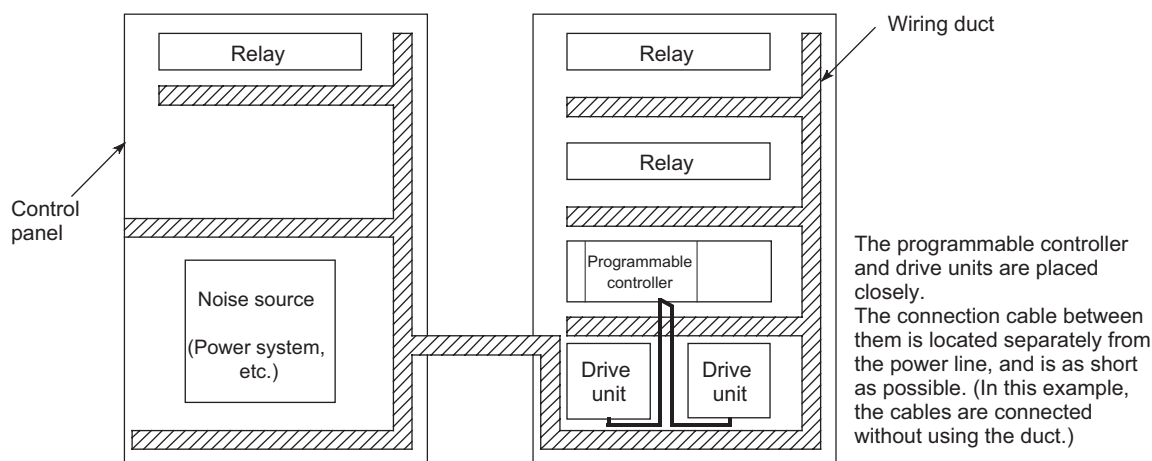

#### (f) I/O signal lines and other communication cables

For the following cables, if pulled out of the control panel, always ground the shield section of these lines and cables in the same manner described in (a).

- I/O signal lines (including a common line)

#### (g) Power cables for external power supply terminal

Use a CE-marked AC-DC power supply as an external power supply for the following modules. Install the AC-DC power supply in the control panel where the module is installed. Keep the length of the power cable connected to the external power supply terminal to 30m or less.

- Analog-digital converter module
- Digital-analog converter module
- High-speed counter module
- Positioning module
- Temperature control module

### (5) External power supply

Use a CE-marked product for an external power supply and always ground the FG terminal.

(External power supply used for the tests conducted by Mitsubishi: TDK-Lambda DLP-120-24-1, IDEC PS5R-SF24)

A

## (6) Power supply module

Always ground the LG and FG terminals after shunting them.

## (7) I/O modules

- Install the DC power in the same control panel with the modules.
- When a cable for the DC power is installed extending outside the control panel, use a shielded cable.
- A cable for the DC power must be 30m or less in length.
- When the number of relay operations is more than 5 times per minute, take measures such as using a surge suppressor.

## (8) High-speed counter module

- Install the DC power in the same control panel with the modules.
- When a cable for the DC power is installed extending outside the control panel, use a shielded cable.
- Keep the length of cables connected to external devices to 30m or less.

## (9) Positioning module

Install the DC power in the same control panel with the modules.

## (10) Temperature control module

Install the DC power in the same control panel with the modules.

## (11) CC-Link module

- To ground the Ver.1.10-compatible CC-Link dedicated cable, refer to  Page 141, Appendix 9.1 (4) (c).
- Each power line connecting to the external power supply terminal or module power supply terminal must be 30m or less.
- Install a noise filter to the external power supply. Use the noise filter having an attenuation characteristic, MA1206 (TDK Lambda) or equivalent. Note that a noise filter is not required if the module is used in Zone A defined in EN61131-2.
- Keep the length of signal cables connected to the analog input terminals of the following modules to 30m or less. Wire cables connected to the external power supply and module power supply terminal in the control panel where the module is installed.
  - AJ65BT-64RD3
  - AJ65BT-64RD4
  - AJ65BT-68TD
- For the cable connected to the power supply terminal of the AJ65SBT-RPS, AJ65SBT-RPG or AJ65BT-68TD, attach a ferrite core with attenuation characteristic equivalent to that of the ZCAT3035-1330 from TDK Corporation. Twist the cable around the ferrite core by one as shown below.

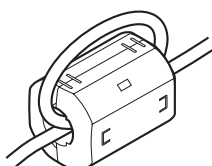

**(12)CC-Link/LT module**

- Use the module under the installation environment of Zone A\*<sup>1</sup>. For the specified Zones of the following products, refer to the manual provided with each product:
  - CL1Y4-R1B1
  - CL1Y4-R1B2
  - CL1XY4-DR1B2
  - CL1XY8-DR1B2
  - CL1PSU-2A
- To supply the CL2DA2-B and CL2AD4-B with power using the CL1PAD1, keep the length of the power cable connected from the CL1PAD1 to the external power supply to 30m or less.

- \*1 Zone defines categories according to industrial environment, specified in the EMC and Low Voltage Directives, EN61131-2.
- Zone C: Factory mains (isolated from public mains by dedicated transformer)
- Zone B: Dedicated power distribution, secondary surge protection (rated voltage: 300V or less)
- Zone A: Local power distribution, protected from dedicated power distribution by AC/DC converter and insulation transformer (rated voltage: 120V or less)

**(13)Others****(a) Ferrite core**

A ferrite core has the effect of reducing radiated noise in the 30MHz to 100MHz band.

It is recommended to attach ferrite cores if shield cables coming out from pulled out of the control panel do not provide sufficient shielding effects.

Note that the ferrite cores must be attached at the position closest to the cable hole inside the control panel. If attached at an improper position, the ferrite core will not produce any effect.

Attach a ferrite core to each power line as illustrated below.

Example

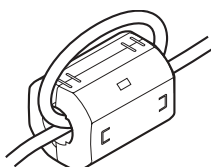
**A**

## (b) Noise filter (power supply line filter)

A noise filter is a component which has an effect on conducted noise.

Attaching the filter can suppress more noise. (The noise filter has the effect of reducing conducted noise of 10 MHz or less.)

The precautions for attaching a noise filter are described below.

- Do not bundle the cables on the input side and output side of the noise filter. If bundled, the output side noise will be induced into the input side cables from which the noise was filtered.

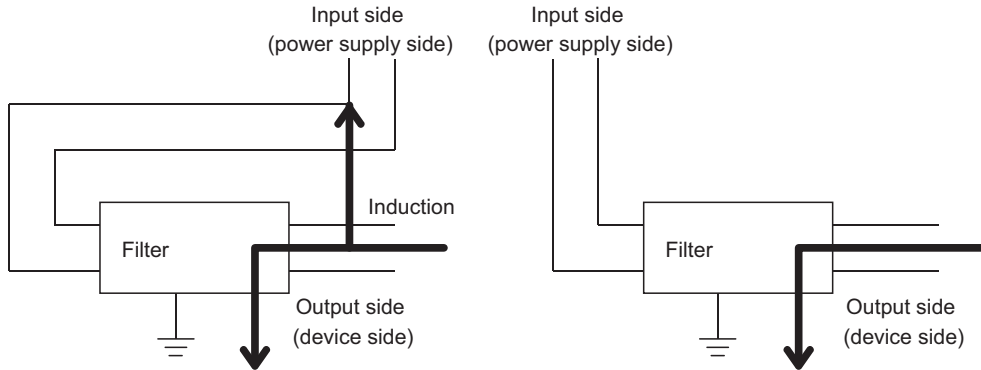

Noise will be induced when the input and output cables are bundled.

Separately install the input and output cables.

- Ground the noise filter grounding terminal to the control panel with the shortest cable possible (approx. 10cm).

## (c) Isolation transformer

An isolation transformer has an effect on reducing conducted noise (especially, lightning surge).

Lightning surge may cause a malfunction of the programmable controller.

As measures against lightning surge noise, connect an isolation transformer as shown below.

Using an isolation transformer will reduce an impact of lightning.

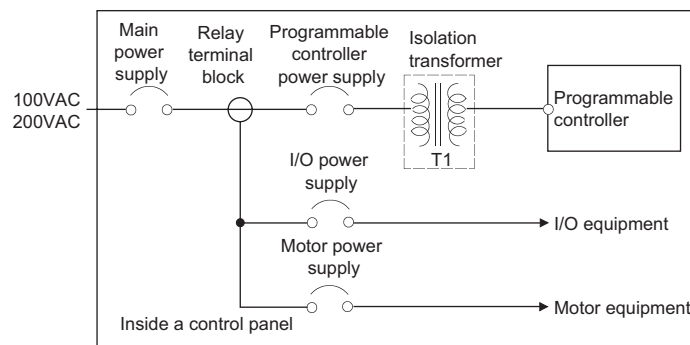

## Appendix 9.2 Requirements to Compliance with the Low Voltage Directive

The Low Voltage Directive requires each device that operates with the power supply ranging from 50 to 1000VAC and 75 to 1500VDC to satisfy the safety requirements.

This section summarizes precautions on using the MELSEC-L series modules to comply with the Low Voltage Directive. These descriptions are based on the requirements and standards of the regulation; however, it does not guarantee that the entire machinery manufactured based on the descriptions complies with the Low Voltage Directive. The method and judgment for the Low Voltage Directive must be left at manufacturer's own discretion.

### (1) Standard applied for MELSEC-L series modules

- EN61010-1 Safety of equipment used in measurements, controls, or laboratories.

The MELSEC-L series modules with a rated voltage of 50VAC and 75VDC or higher have been also developed to conform to the above standard.

The modules which operate at the rated voltage of less than 50VAC and 75VDC are out of the Low Voltage Directive application range.

### (2) MELSEC-L series module selection

#### (a) Power supply module

There are dangerous voltages (voltages higher than or equal to 42.4V peak) inside the power supply modules of 100VAC and 200VAC rated input voltages. Therefore, for CE-marked products, insulation is reinforced internally between the primary and secondary circuits.

#### (b) I/O modules

There are dangerous voltages (voltages higher than or equal to 42.4V peak) in the I/O modules of 100VAC and 200VAC rated I/O voltages. Therefore, for CE-marked products, insulation is reinforced internally between the primary and secondary circuits.

The I/O modules of 24VDC or less rating are out of the Low Voltage Directive application range.

#### (c) GOT

Use a CE-marked product.

#### (d) Modules not relevant to the Low and Voltage Directive

Using 5VDC circuit inside, the following modules are out of the Low Voltage Directive application range.

- Head module
- END cover

The intelligent function modules are out of the scope of the Low Voltage Directive because the rated voltage is 24VDC or less.

### (3) Power supply

The insulation specification of the power supply module was designed assuming Installation Category II. Satisfy the Installation Category II for the power supply to the programmable controller.

A

## (4) Control panel

### (a) Electrical shock prevention

The control panel must be handled as shown below to protect a person who does not have adequate knowledge of electricity from an electric shock.

- Lock the control panel so that only those who are trained and have acquired enough knowledge of electric facilities can open the control panel.
- The control panel must have a structure that automatically stops the power supply when the control panel is opened.
- Use the control panel whose protection degree is IP20 or higher for the purpose of electric shock protection.

### (b) Dustproof and waterproof features

The control panel also has the dustproof and waterproof functions. Insufficient dustproof and waterproof features lower the dielectric withstand voltage, resulting in insulation destruction.



The insulation in our programmable controllers are designed to cope with the pollution level 2, so use it in an environment with pollution level 2 or below.

The pollution level 2 environments can be achieved when the programmable controller is stored in a control panel equivalent to IP54.

## (5) Grounding

There are the following two different ground terminals.

Use the ground terminals in grounded status.

Terminal	Application
Protective grounding 	Ensures the safety of the programmable controller and improves the noise resistance.
Functional grounding 	Improves the noise resistance.

## (6) External wiring

### (a) 24VDC external power supply

For the 24VDC I/O modules and intelligent function modules requiring an external power supply, use a 24VDC-circuit whose insulation is reinforced from the hazardous voltage circuit.

### (b) External devices

When a device with hazardous voltage circuit is externally connected to the programmable controller, use a device whose circuit section of the interface to the programmable controller is intensively insulated from the hazardous voltage circuit.

### (c) Reinforced insulation

The reinforced insulation covers the withstand voltages shown below.

Rated voltage of hazardous voltage area	Surge withstand voltage (1.2/50 $\mu$ s)
150VAC or lower	2500V
300VAC or lower	4000V

(Installation Category II, source: IEC 664)

# Appendix 10 General Safety Requirements

---

When a programmable controller is powered on or off, normal control outputs may not be performed temporarily. This is because there is a time lag for the power to be turned on between the programmable controller power supply and the external power supply (especially, DC) for the control target. Normal control outputs also may not be performed when the external power supply or the programmable controller fails.

In terms of fail-safe and to prevent any of these abnormal operations from leading to the entire network system failure, configure safety circuits (such as emergency stop circuits, protection circuits, or interlock circuits, where abnormal operation may result in mechanical damage or accidents) external to the programmable controller.

## (1) Fail-safe measures for head module failure

A head module can detect its own hardware failures by the self-diagnostic function. However, failures which occur in a part, such as an I/O control part, may not be detected.

In this case, depending on the failure, all input or output points may turn on or off, or normal operation and safety of the control-target device may not be ensured.

Even though Mitsubishi programmable controllers are manufactured under strict quality control, they may fail due to some reasons. Provide fail-safe circuits external to the programmable controller so that no machine is damaged and no accident occurs.

**A**

# Appendix 11 Calculating Heating Value of Programmable Controller

---

The ambient temperature inside the control panel where a head module is installed must be 55°C or less.

It is necessary to know the average power consumption (heating value) of the equipment and devices installed inside the control panel when designing a heat release structure of the panel.

This section describes the calculation method of the average power consumption of a programmable controller system.

Calculate a rise in ambient temperature inside the control panel according to the power consumption.

## Appendix 11.1 Calculating the average power consumption

---

The total of the power consumption calculated for each block is the power consumption of the entire programmable controller system.

$$W = W_{PW} + W_{5V} + W_{24V} + W_{OUT} + W_{IN} + W_S (W)$$

Calculate a heating value and a rise in ambient temperature inside the control panel according to the calculated power consumption (W).

The calculation formula for a rise in ambient temperature inside the control panel is as follows.

$$T = \frac{W}{UA} [^{\circ}\text{C}]$$

W: Power consumption of the entire programmable controller system

A: Surface area inside the control panel [m<sup>2</sup>]

U (=6): When the ambient temperature inside the control panel is uniformed using a fan

U (=4): When the air inside the control panel is not circulated

---

### Point

- If the temperature inside the control panel is expected to exceed the specified range, it is recommended to install a heat exchanger to the panel to lower the temperature.
  - If a general-purpose fan is used, dust will be sucked into the control panel with the external air. This may affect the performance of the programmable controller.
- 

The calculation formulas for the power consumption of each block are as follows.

#### (1) Power consumption of power supply module

The power conversion efficiency of the power supply module is approximately 70% and 30% of the output power is consumed as heat. As a result, 3/7 of the output power will be the power consumption.

The calculation formula is as follows.

$$W_{PW} = \frac{3}{7} \times \{ (I_{5V} \times 5) + (I_{24V} \times 24) \} (W)$$

I<sub>5V</sub>: Current consumption of 5VDC circuit of each module

I<sub>24V</sub>: Average current consumption of 24VDC power supply for internal consumption of the output module (power consumption for the output points simultaneously turned on) \*1

\*1 Not applicable for the power supply module which does not have the 24VDC power output. (Power (24VDC) is externally supplied.)



**(2) Power consumption of 5VDC logic circuit sections in all modules (including the head module)**

The power consumption of the 5VDC output circuit in the power supply module is the power consumption of each module.

$$W_{5V} = I_{5V} \times 5 \text{ (W)}$$

**(3) Total of 24VDC average power consumption of the output modules (power consumption for the output points simultaneously turned on)**

The average power of the 24VDC external power supply is the total power consumption of each module.

$$W_{24V} = I_{24V} \times 24 \times \text{Simultaneous ON rate (W)}$$

**(4) Voltage drop in the output section of the output module (power consumption for the output points simultaneously turned on)**

$$W_{OUT} = I_{OUT} \times V_{drop} \times \text{output points} \times \text{Simultaneous ON rate (W)}$$

$I_{OUT}$ : Output current (current in actual use) (A)

$V_{drop}$ : Voltage drop of each output module (V)

**(5) Average power consumption of input section in the input module (power consumption for the input points simultaneously turned on)**

$$W_{IN} = I_{IN} \times E \times \text{Input points} \times \text{Simultaneous ON rate (W)}$$

$I_{IN}$ : Input current (effective value for AC) (A)

E: Input voltage (voltage in actual use) (V)

**(6) Power consumption of the external power supply section to the load(s) connected to the intelligent function module**

$$W_S = I_{24V} \times 24 \text{ (W)}$$

# Appendix 12 Processing Time

---

The calculation formula for the I/O response time of the head module is as follows:

$$\text{Rio} = (\text{RX/RY points}) \times 0.16 + (\text{RWw/RWr points}) \times 5.5 \\ + 430 + \text{Ka} + (\text{response time of the connected module}) [\mu\text{s}]$$

The above formula calculates the average value when the number of RX/RY points is the same as the number of actual I/O points of the module connected to the head module, and an auto refresh of the same number of points as the number of RWw/RWr points was executed.

Rio:	I/O response time of the head module
RX/RY points:	The number of points set for "RX/RY Setting" in the Network Configuration Setting of the master station
RWw/RWr points:	The number of points set for "RWw/RWr Setting" in the Network Configuration Setting of the master station
Ka:	The value to add when auto refresh of the intelligent function module was performed = 140
Response time of the connected module:	 Manual for each module used

---

## **Point**

To calculate the processing time of the CC-Link IE Field Network, add the I/O response time of the head module to the processing time of the slave stations.



For information on processing time of the CC-Link IE Field Network, refer to the following.

 User's manual for the master/local module used.

---

## Appendix 13 New Function and Improved Function

The following table shows a new function and improved function.

New function and improved function	Module supporting the function (first five digits of the serial number)	GX Works2 supporting the function
Addition of applicable modules (positioning module and simple motion module) (  Page 36, Section 5.2)	"12072" or later	Version 1.31H or later
Indication of loopback execution by L ERR. LED (  Page 22, CHAPTER 2)	"12072" or later	-
Addition of a loopback detection feature for Connection status (own station) (SW0064) (  Page 122, Appendix 5)	"13032" or later	-

A

## Appendix 14 Checking Serial Number and Function Version

The serial number and function version of the head module can be checked on any of the following:

- Rating plate
- Front of the module
- System Monitor in GX Works2

### (1) Checking on the rating plate

The rating plate is located on the side of the head module.

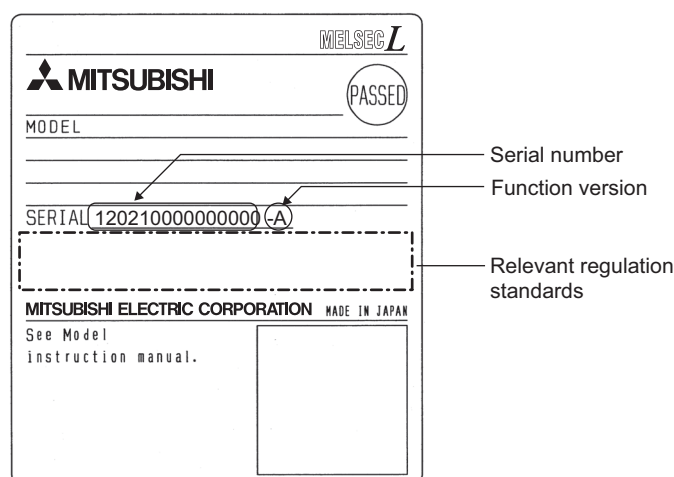

**(2) Checking on the front of the module**

The serial number on the rating plate is printed on the front (at the bottom) of the module.

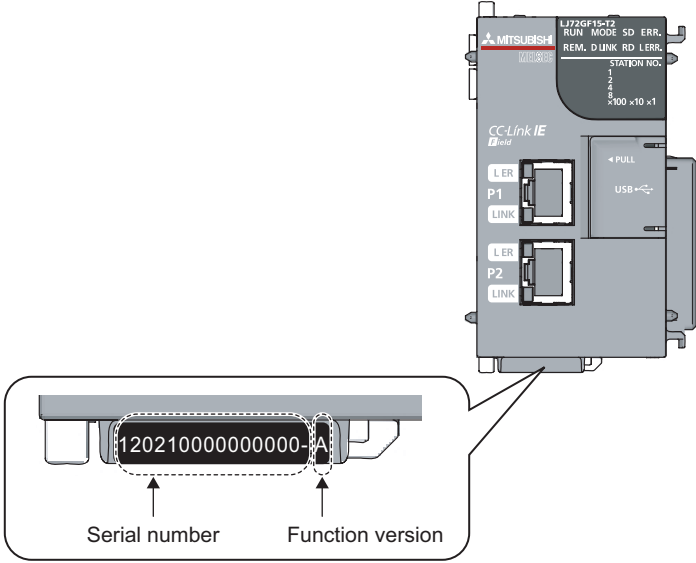

### (3) Checking on the System Monitor screen

The serial number and function version can be checked on the "Product Information List" screen.

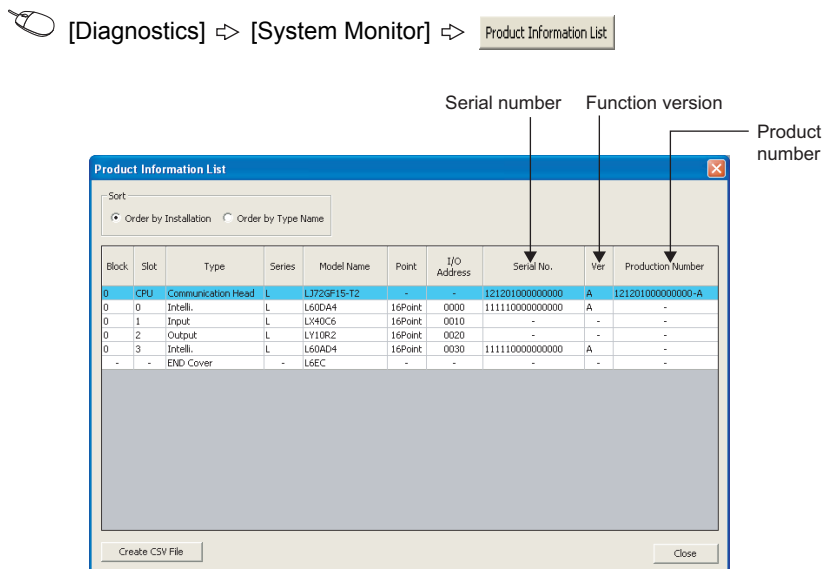

On the screen, the serial number and function version of each intelligent function module can be checked as well.

The serial number of the module is displayed in the "Serial No." column.

The function version of the module is displayed in the "Ver" column.

If the module supports the production number display, the serial number (production number) printed on the rating plate of the module is displayed in the "Production Number" column.



The serial number displayed on the Product Information List screen of GX Works2 may differ from that on the rating plate or on the front of the module.

- The serial number on the rating plate or on the front of the module indicates the management information of the product.
- The serial number displayed in the Product Information List of GX Works2 indicates the functional information of the product. The functional information of the product is updated when a new function is added.

# Appendix 15 External Dimensions

## (1) Head module (LJ72GF15-T2)

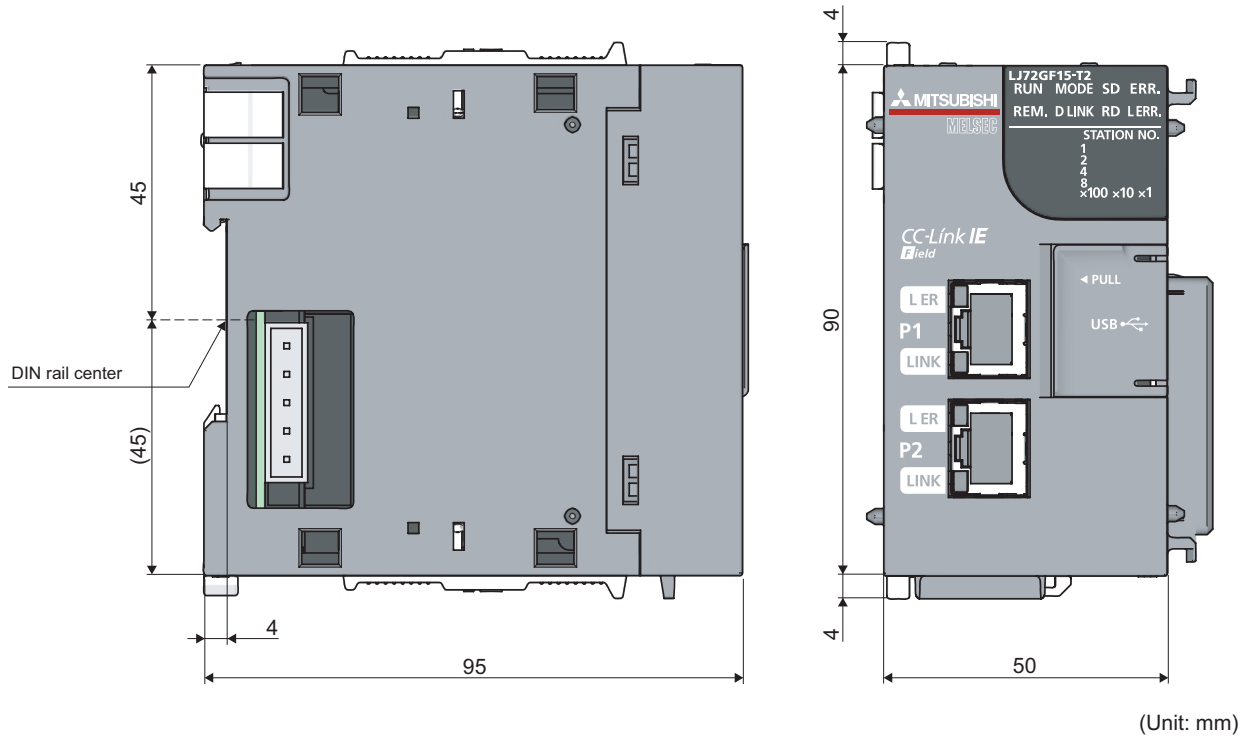

## (2) END cover (L6EC)

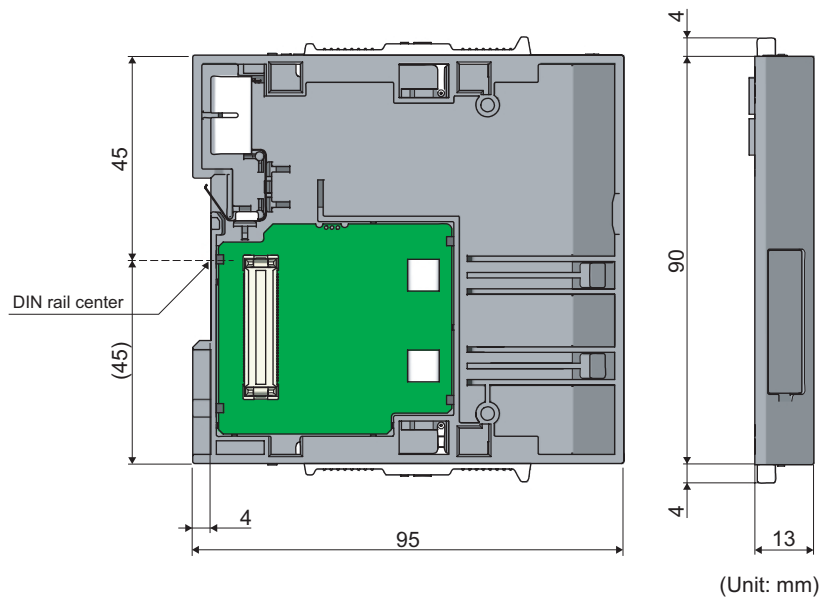

# Memo

---

A

Appendix 15 External Dimensions

# INDEX

<b>A</b>		
Access code . . . . .	136	
Applicable DIN rail model (IEC 60715) . . . . .	42	
Applicable systems . . . . .	36	
Attribute code . . . . .	136	
Auto refresh . . . . .	28	
<b>B</b>		
Bending radius of the Ethernet cable . . . . .	50	
<b>C</b>		
Cable test . . . . .	80	
Calculating heating value of programmable controller . . . . .	150	
Calculating the average power consumption . . . . .	150	
CC-Link IE Field Network . . . . .	16	
CC-Link IE Field Network diagnostics . . . . .	75	
Changing modules on a DIN rail . . . . .	43	
Checking for failure of a module other than the head module . . . . .	88	
Checking for failure of the head module . . . . .	86	
Checking serial number and function version . . . . .	153	
Checking the error history . . . . .	89	
Checking the LEDs . . . . .	91	
Communication Head Setting . . . . .	53	
Communication test . . . . .	80	
Connectable modules and the number of modules. . . . .	36	
Connecting modules. . . . .	39	
Connecting the Ethernet cable. . . . .	47	
Cyclic transmission . . . . .	16,19,29,65	
Cyclic transmission cannot be performed. . . . .	94	
<b>D</b>		
D LINK LED . . . . .	22	
Daily inspection . . . . .	82	
Data flow . . . . .	66,72	
Data link . . . . .	16	
Dedicated instruction . . . . .	16	
Device . . . . .	16	
Diagnostic information . . . . .	126,129	
Diagnostic items . . . . .	75	
Diagnostic screen . . . . .	78	
Diagnostics . . . . .	29	
DIN rail stopper . . . . .	42	
Disconnection . . . . .	16	
Drive information . . . . .	127,135	
<b>E</b>		
END cover . . . . .	120	
ERR. LED . . . . .	23	
Error code list (1 to 10000) . . . . .	96	
Error code list (D000H to DFFFH) . . . . .	102	
Error Time Output Mode . . . . .	61	
Example of changing the head module. . . . .	34	
External dimensions. . . . .		28,156
<b>F</b>		
Fail-safe measures for head module failure . . . . .	149	
File password 32 . . . . .	29,113	
Forced on/off of external input/output . . . . .	29	
Function list . . . . .	29	
<b>G</b>		
General safety requirements . . . . .	149	
General specifications . . . . .	26	
Grounding. . . . .	49	
<b>H</b>		
Head module . . . . .	16,19	
Head module system configuration . . . . .	35	
<b>I</b>		
I/O Assignment . . . . .	61	
I/O Response Time . . . . .	61	
Initial setting . . . . .	28	
Installation . . . . .	38	
Installation and wiring. . . . .	37	
Installation environment . . . . .	37	
Installation position . . . . .	37	
Intelligent device station . . . . .	16	
Intelligent function module parameters. . . . .	64	
Internal current consumption (5VDC) . . . . .	28	
Interval between DIN rail mounting screws. . . . .	42	
<b>L</b>		
L ER LED . . . . .	23	
L ERR. LED . . . . .	23	
Laying Ethernet cables. . . . .	50	
Link dedicated instruction . . . . .	16	
Link device . . . . .	16	
LINK LED . . . . .	23	
Link special register (SW) . . . . .	17	
Link special register (SW) list . . . . .	122	
Link special relay (SB) . . . . .	17	
Link special relay (SB) list. . . . .	121	
Local station . . . . .	16	
<b>M</b>		
Maintenance and inspection . . . . .	82	
Manual page organization. . . . .	15	
Master station . . . . .	16	
Master/local module. . . . .	16	
Maximum station-to-station distance (Maximum Ethernet cable length) . . . . .	50	
Mode . . . . .	53	
MODE LED. . . . .	22	



Module Error History Collection (Intelligent Function Module) . . . . .	56
Modules/unit that cannot be connected . . . . .	36
Monitoring/test . . . . .	29
Mounting the modules on a DIN rail . . . . .	40

## N

Network module . . . . .	16
Network No. . . . .	27,53
Network parameters . . . . .	62
Number of device points . . . . .	27
Number of I/O points . . . . .	27

## O

Operation mode setting for a hardware error . . . . .	29
Operation Setting . . . . .	57
Operation Test . . . . .	79
Output mode setting for error . . . . .	29
Output status for each status . . . . .	70

## P

P1 . . . . .	23
P2 . . . . .	23
Packing list. . . . .	18
Parameter setting . . . . .	51
Part names. . . . .	22
Password authentication . . . . .	118
Performance specifications . . . . .	27
Periodic inspection . . . . .	83
PLC Name . . . . .	54
PLC Operation Mode at H/W Error . . . . .	61
PLC parameters . . . . .	52
PLC RAS . . . . .	56
PLC System . . . . .	55
Procedure for changing the head module . . . . .	32
Procedures before operation . . . . .	30
Processing time . . . . .	152
Programming tool . . . . .	16

## R

RD LED . . . . .	22
Reconnection . . . . .	16
Relay station . . . . .	16
Relevant manuals . . . . .	10
REM. LED . . . . .	22
Remote device station . . . . .	16
Remote I/O station . . . . .	16
Remote input (RX) . . . . .	16
Remote operation . . . . .	81
Remote output (RY) . . . . .	17
Remote password . . . . .	29,63
Remote register (RW <sub>r</sub> ) . . . . .	17
Remote register (RW <sub>w</sub> ) . . . . .	17
Remote RESET . . . . .	29
Remote Reset . . . . .	55
Remote RUN/STOP . . . . .	29
Reserved station . . . . .	16
RESET/TEST . . . . .	24
Routing . . . . .	16

RUN . . . . .	24
RUN LED. . . . .	22

## S

Safety precautions . . . . .	1
SD LED . . . . .	22
Selected Station Communication Status Monitor . . . . .	79
Selected Station Operation . . . . .	79
Serial number display . . . . .	23
Setting file passwords . . . . .	114
Setting method . . . . .	69,74
Slave station . . . . .	16
Software package . . . . .	36
Special register (SD) list . . . . .	128
Special relay (SM) list . . . . .	125
Specifications . . . . .	26
Station No. . . . .	27,53
Station number setting from master station . . . . .	29
STOP . . . . .	24
Switch . . . . .	24
System clock/counter . . . . .	126
System configuration . . . . .	35
System error history . . . . .	29,89
System information . . . . .	133
System monitor . . . . .	81

## T

Term . . . . .	16
Testing the head module before wiring . . . . .	45
Transient transmission . . . . .	16,20,29
Transient transmission cannot be performed. . . . .	94
Troubleshooting . . . . .	84
Troubleshooting by symptom . . . . .	94
Troubleshooting procedure . . . . .	84

## U

Unit test . . . . .	45
---------------------	----

## W

Weight . . . . .	28
When the D LINK LED is flashing . . . . .	92
When the D LINK LED turned off . . . . .	92
When the ERR. LED turned on . . . . .	92
When the L ERR. LED turned on . . . . .	93
When the LINK LED turned off . . . . .	93
When the MODE LED is flashing . . . . .	91
When the MODE LED turned off . . . . .	91
When the REM. LED is flashing . . . . .	93
When the REM. LED turned off . . . . .	93
When the RUN LED is flashing . . . . .	91
When the RUN LED turned off . . . . .	91
Wiring to the head module . . . . .	47
Wiring to the power supply modules . . . . .	45

# REVISIONS

\*The manual number is given on the bottom left of the back cover.

Print date	*Manual number	Revision
April 2010	SH(NA)-080919ENG-A	First edition
September 2010	SH(NA)-080919ENG-B	<p><b>Partial correction</b> Chapter 2, Section 3.2, 5.2, 6.5.1, 8.1, 11.4, 11.6, Appendix 5, 11</p> <p><b>Addition</b> Appendix 12</p> <p><b>Chapter change</b> Appendix 12→13, Appendix 13→14</p>
May 2011	SH(NA)-080919ENG-C	<p><b>Partial correction</b> Section 3.2, 4.2, 5.2, 8.1, 8.2, 11.6, Appendix 5, 12</p>
November 2011	SH(NA)-080919ENG-D	<p><b>Addition</b> Appendix 9</p> <p><b>Chapter change</b> Appendix 9 to 14→ Appendix 10 to 15</p>

Japanese manual version SH-080918-E

This manual confers no industrial property rights or any rights of any other kind, nor does it confer any patent licenses. Mitsubishi Electric Corporation cannot be held responsible for any problems involving industrial property rights which may occur as a result of using the contents noted in this manual.

# **WARRANTY**

Please confirm the following product warranty details before using this product.

## **1. Gratis Warranty Term and Gratis Warranty Range**

If any faults or defects (hereinafter "Failure") found to be the responsibility of Mitsubishi occurs during use of the product within the gratis warranty term, the product shall be repaired at no cost via the sales representative or Mitsubishi Service Company.

However, if repairs are required onsite at domestic or overseas location, expenses to send an engineer will be solely at the customer's discretion. Mitsubishi shall not be held responsible for any re-commissioning, maintenance, or testing on-site that involves replacement of the failed module.

[Gratis Warranty Term]

The gratis warranty term of the product shall be for one year after the date of purchase or delivery to a designated place.

Note that after manufacture and shipment from Mitsubishi, the maximum distribution period shall be six (6) months, and the longest gratis warranty term after manufacturing shall be eighteen (18) months. The gratis warranty term of repair parts shall not exceed the gratis warranty term before repairs.

[Gratis Warranty Range]

- (1) The range shall be limited to normal use within the usage state, usage methods and usage environment, etc., which follow the conditions and precautions, etc., given in the instruction manual, user's manual and caution labels on the product.
- (2) Even within the gratis warranty term, repairs shall be charged for in the following cases.
  1. Failure occurring from inappropriate storage or handling, carelessness or negligence by the user. Failure caused by the user's hardware or software design.
  2. Failure caused by unapproved modifications, etc., to the product by the user.
  3. When the Mitsubishi product is assembled into a user's device, Failure that could have been avoided if functions or structures, judged as necessary in the legal safety measures the user's device is subject to or as necessary by industry standards, had been provided.
  4. Failure that could have been avoided if consumable parts (battery, backlight, fuse, etc.) designated in the instruction manual had been correctly serviced or replaced.
  5. Failure caused by external irresistible forces such as fires or abnormal voltages, and Failure caused by force majeure such as earthquakes, lightning, wind and water damage.
  6. Failure caused by reasons unpredictable by scientific technology standards at time of shipment from Mitsubishi.
  7. Any other failure found not to be the responsibility of Mitsubishi or that admitted not to be so by the user.

## **2. Onerous repair term after discontinuation of production**

- (1) Mitsubishi shall accept onerous product repairs for seven (7) years after production of the product is discontinued.  
Discontinuation of production shall be notified with Mitsubishi Technical Bulletins, etc.
- (2) Product supply (including repair parts) is not available after production is discontinued.

## **3. Overseas service**

Overseas, repairs shall be accepted by Mitsubishi's local overseas FA Center. Note that the repair conditions at each FA Center may differ.

## **4. Exclusion of loss in opportunity and secondary loss from warranty liability**

Regardless of the gratis warranty term, Mitsubishi shall not be liable for compensation of damages caused by any cause found not to be the responsibility of Mitsubishi, loss in opportunity, lost profits incurred to the user by Failures of Mitsubishi products, special damages and secondary damages whether foreseeable or not, compensation for accidents, and compensation for damages to products other than Mitsubishi products, replacement by the user, maintenance of on-site equipment, start-up test run and other tasks.

## **5. Changes in product specifications**

The specifications given in the catalogs, manuals or technical documents are subject to change without prior notice.

Microsoft, Windows, Windows NT, and Windows Vista are registered trademarks of Microsoft Corporation in the United States and other countries.

Pentium is a trademark of Intel Corporation in the United States and other countries.

Ethernet is a trademark of Xerox Corporation.

All other company names and product names used in this manual are trademarks or registered trademarks of their respective companies.



# MELSEC-L CC-Link IE Field Network Head Module User's Manual

MODEL	LJ72GF15-T2-U-E
MODEL CODE	13JZ48
SH(NA)-080919ENG-D(1111)MEE	



HEAD OFFICE : TOKYO BUILDING, 2-7-3 MARUNOUCHI, CHIYODA-KU, TOKYO 100-8310, JAPAN  
NAGOYA WORKS : 1-14, YADA-MINAMI 5-CHOME, HIGASHI-KU, NAGOYA, JAPAN

When exported from Japan, this manual does not require application to the  
Ministry of Economy, Trade and Industry for service transaction permission.

Specifications subject to change without notice.



**HEADQUARTERS**

MITSUBISHI ELECTRIC EUROPE B.V. **EUROPE**  
 German Branch  
 Gothaer Straße 8  
**D-40880 Ratingen**  
 Phone: +49 (0)2102 / 486-0  
 Fax: +49 (0)2102 / 486-1120

MITSUBISHI ELECTRIC EUROPE B.V.-org.sl. **CZECH REP.**  
 Czech Branch  
 Avenir Business Park, Radlická 714/113a  
**CZ-158 00 Praha 5**  
 Phone: +420 - 251 551 470  
 Fax: +420 - 251-551-471

MITSUBISHI ELECTRIC EUROPE B.V. **FRANCE**  
 French Branch  
 25, Boulevard des Bouvets  
**F-92741 Nanterre Cedex**  
 Phone: +33 (0)1 / 55 68 55 68  
 Fax: +33 (0)1 / 55 68 57 57

MITSUBISHI ELECTRIC EUROPE B.V. **IRELAND**  
 Irish Branch  
 Westgate Business Park, Ballymount  
**IRL-Dublin 24**  
 Phone: +353 (0)1 4198800  
 Fax: +353 (0)1 4198890

MITSUBISHI ELECTRIC EUROPE B.V. **ITALY**  
 Italian Branch  
 Viale Colleoni 7  
**I-20041 Agrate Brianza (MB)**  
 Phone: +39 039 / 60 53 1  
 Fax: +39 039 / 60 53 312

MITSUBISHI ELECTRIC EUROPE B.V. **POLAND**  
 Poland Branch  
 Krakowska 50  
**PL-32-083 Balice**  
 Phone: +48 (0)12 / 630 47 00  
 Fax: +48 (0)12 / 630 47 01

MITSUBISHI ELECTRIC EUROPE B.V. **RUSSIA**  
 52, bid. 3 Kosmodamiyanskaya nab 8 floor  
**RU-115054 Moscow**  
 Phone: +7 495 721-2070  
 Fax: +7 495 721-2071

MITSUBISHI ELECTRIC EUROPE B.V. **SPAIN**  
 Spanish Branch  
 Carretera de Rubí 76-80  
**E-08190 Sant Cugat del Vallés (Barcelona)**  
 Phone: 902 131121 // +34 935653131  
 Fax: +34 935891579

MITSUBISHI ELECTRIC EUROPE B.V. **UK**  
 UK Branch  
 Travellers Lane  
**UK-Hatfield, Herts. AL10 8XB**  
 Phone: +44 (0)1707 / 27 61 00  
 Fax: +44 (0)1707 / 27 86 95

MITSUBISHI ELECTRIC CORPORATION **JAPAN**  
 Office Tower "Z" 14 F  
 8-12,1 chome, Harumi Chuo-Ku  
**Tokyo 104-6212**  
 Phone: +81 3 622 160 60  
 Fax: +81 3 622 160 75

MITSUBISHI ELECTRIC AUTOMATION, Inc. **USA**  
 500 Corporate Woods Parkway  
**Vernon Hills, IL 60061**  
 Phone: +1 847 478 21 00  
 Fax: +1 847 478 22 53

**EUROPEAN REPRESENTATIVES**

GEVA **AUSTRIA**  
 Wiener Straße 89  
**AT-2500 Baden**  
 Phone: +43 (0)2252 / 85 55 20  
 Fax: +43 (0)2252 / 488 60

TECHNIKON **BELARUS**  
 Oktyabrskaya 19, Off. 705  
**BY-220030 Minsk**  
 Phone: +375 (0)17 / 210 46 26  
 Fax: +375 (0)17 / 210 46 26

ESCO DRIVES & AUTOMATION **BELGIUM**  
 Culliganlaan 3  
**BE-1831 Diegem**  
 Phone: +32 (0)2 / 717 64 30  
 Fax: +32 (0)2 / 717 64 31

Koning & Hartman b.v. **BELGIUM**  
 Woluwelaan 31  
**BE-1800 Vilvoorde**  
 Phone: +32 (0)2 / 257 02 40  
 Fax: +32 (0)2 / 257 02 49

INEA RBT d.o.o. **BOSNIA AND HERZEGOVINA**  
 Aleja Lipa 56  
**BA-71000 Sarajevo**  
 Phone: +387 (0)33 / 921 164  
 Fax: +387 (0)33 / 524 539

AKHNATON **BULGARIA**  
 4, Andrej Ljapchev Blvd., PO Box 21  
**BG-1756 Sofia**  
 Phone: +359 (0)2 / 817 6000  
 Fax: +359 (0)2 / 97 44 06 1

INEA RBT d.o.o. **CROATIA**  
 Losinjska 4 a  
**HR-10000 Zagreb**  
 Phone: +385 (0)1 / 36 940 -01 / -02 / -03  
 Fax: +385 (0)1 / 36 940 -03

AutoCont C.S. s.r.o. **CZECH REPUBLIC**  
 Technologická 374/6  
**CZ-708 00 Ostrava-Pustkovec**  
 Phone: +420 595 691 150  
 Fax: +420 595 691 199

Beijer Electronics A/S **DENMARK**  
 Lykkegårdsvej 17  
**DK-4000 Roskilde**  
 Phone: +45 (0)46 / 75 76 66  
 Fax: +45 (0)46 / 75 56 26

Beijer Electronics Eesti OÜ **ESTONIA**  
 Pärnu mnt.160i  
**EE-11317 Tallinn**  
 Phone: +372 (0)6 / 51 81 40  
 Fax: +372 (0)6 / 51 81 49

Beijer Electronics OY **FINLAND**  
 Peltoie 37  
**FIN-28400 Ulvila**  
 Phone: +358 (0)207 / 463 540  
 Fax: +358 (0)207 / 463 541

UTEKO **GREECE**  
 5, Mavrogenous Str.  
**GR-18542 Piraeus**  
 Phone: +30 211 / 1206 900  
 Fax: +30 211 / 1206 999

MELTRADE Kft. **HUNGARY**  
 Fertő utca 14.  
**HU-1107 Budapest**  
 Phone: +36 (0)1 / 431-9726  
 Fax: +36 (0)1 / 431-9727

Beijer Electronics SIA **LATVIA**  
 Rītašmaus iela 23  
**LV-1058 Riga**  
 Phone: +371 (0)784 / 2280  
 Fax: +371 (0)784 / 2281

Beijer Electronics UAB **LITHUANIA**  
 Savanoriu Pr. 187  
**LT-02300 Vilnius**  
 Phone: +370 (0)5 / 232 3101  
 Fax: +370 (0)5 / 232 2980

**EUROPEAN REPRESENTATIVES**

ALFATRADE Ltd. **MALTA**  
 99, Paola Hill  
**Malta- Paola PLA 1702**  
 Phone: +356 (0)21 / 697 816  
 Fax: +356 (0)21 / 697 817

INTEHSIS srl **MOLDOVA**  
 bld. Traian 23/1  
**MD-2060 Kishinev**  
 Phone: +373 (0)22 / 66 4242  
 Fax: +373 (0)22 / 66 4280

HIFLEX AUTOM.TECHNIEK B.V. **NETHERLANDS**  
 Wolweverstraat 22  
**NL-2984 CD Ridderkerk**  
 Phone: +31 (0)180 - 46 60 04  
 Fax: +31 (0)180 - 44 23 55

Koning & Hartman b.v. **NETHERLANDS**  
 Haarlerbergweg 21-23  
**NL-1101 CH Amsterdam**  
 Phone: +31 (0)20 / 587 76 00  
 Fax: +31 (0)20 / 587 76 05

Beijer Electronics AS **NORWAY**  
 Postboks 487  
**NO-3002 Drammen**  
 Phone: +47 (0)32 / 24 30 00  
 Fax: +47 (0)32 / 84 85 77

Fonseca S.A. **PORTUGAL**  
 R. João Francisco do Casal 87/89  
**PT - 3801-997 Aveiro, Esgueira**  
 Phone: +351 (0)234 / 303 900  
 Fax: +351 (0)234 / 303 910

Sirius Trading & Services srl **ROMANIA**  
 Aleea Lacul Morii Nr. 3  
**RO-060841 Bucuresti, Sector 6**  
 Phone: +40 (0)21 / 430 40 06  
 Fax: +40 (0)21 / 430 40 02

INEA RBT d.o.o. **SERBIA**  
 Izletnicka 10  
**SER-113000 Smederevo**  
 Phone: +381 (0)26 / 615 401  
 Fax: +381 (0)26 / 615 401

SIMAP s.r.o. **SLOVAKIA**  
 Jána Derku 1671  
**SK-911 01 Trenčín**  
 Phone: +421 (0)32 743 04 72  
 Fax: +421 (0)32 743 75 20

PROCONT, spol. s r.o. **SLOVAKIA**  
 Prešov  
 Kúpeľná 1/A  
**SK-080 01 Prešov**  
 Phone: +421 (0)51 7580 611  
 Fax: +421 (0)51 7580 650

INEA RBT d.o.o. **SLOVENIA**  
 Stegne 11  
**SI-1000 Ljubljana**  
 Phone: +386 (0)1 / 513 8116  
 Fax: +386 (0)1 / 513 8170

Beijer Electronics AB **SWEDEN**  
 Box 426  
**SE-20124 Malmö**  
 Phone: +46 (0)40 / 35 86 00  
 Fax: +46 (0)40 / 93 23 01

Omni Ray AG **SWITZERLAND**  
 Im Schörlí 5  
**CH-8600 Dübendorf**  
 Phone: +41 (0)44 / 802 28 80  
 Fax: +41 (0)44 / 802 28 28

GTS **TURKEY**  
 Bayraktar Bulvarı Nutuk Sok. No:5  
**TR-34775 Yukarı Dudullu-Ümraniye-İSTANBUL**  
 Phone: +90 (0)216 526 39 90  
 Fax: +90 (0)216 526 3995

CSC Automation Ltd. **UKRAINE**  
 4-B, M. Raskovoyi St.  
**UA-02660 Kiev**  
 Phone: +380 (0)44 / 494 33 55  
 Fax: +380 (0)44 / 494-33-66

Systemgroup **UKRAINE**  
 2 M. Krivonosy St.  
**UA-03680 Kiev**  
 Phone: +380 (0)44 / 490 92 29  
 Fax: +380 (0)44 / 248 88 68

**EURASIAN REPRESENTATIVES**

TOO Kazpromavtomatika **KAZAKHSTAN**  
 Ul. Zhambyla 28  
**KAZ-100017 Karaganda**  
 Phone: +7 7212 / 50 10 00  
 Fax: +7 7212 / 50 11 50

**MIDDLE EAST REPRESENTATIVES**

ILAN & GAVISH Ltd. **ISRAEL**  
 24 Shenkar St., Kiryat Arie  
**IL-49001 Petah-Tiqva**  
 Phone: +972 (0)3 / 922 18 24  
 Fax: +972 (0)3 / 924 0761

GIRIT CELADON LTD **ISRAEL**  
 12 H'aomanut Street  
**IL-42505 Netanya**  
 Phone: +972 (0)9 / 863 39 80  
 Fax: +972 (0)9 / 885 24 30

CEG INTERNATIONAL **LEBANON**  
 Cebaco Center/Block A Autostrade DORA  
**Lebanon - Beirut**  
 Phone: +961 (0)1 / 240 430  
 Fax: +961 (0)1 / 240 438

**AFRICAN REPRESENTATIVE**

CBI Ltd. **SOUTH AFRICA**  
 Private Bag 2016  
**ZA-1600 Isando**  
 Phone: + 27 (0)11 / 977 0770  
 Fax: + 27 (0)11 / 977 0761