



<b>Identification</b>	Type	STGK-M12 4POL SNK
	Part-No.	490028
<b>Description</b>	field wireable connector, M12 straight Male / female - A coded Fast connection method, IDC method of termination	
<b>Technical data</b>		
Nominal voltage	AC/DC 24 V	
Nominal voltage range	250 V	
Rated current	4 A	
Number of terminations	4	
Coding	A	
Contact resistance	<5 mΩ	
<b>General</b>		
Form	M12 × 1, male	
Rated insulation voltage (EN 50178)	300 V	
Test voltage	2.5 kV	
Pollution degree	3	
Insulation resistance	>10 <sup>9</sup> Ω	
Contact resistance	<5 mΩ	

14.11.2013 – Subject to technical modification

Part-No. 490028

USA: LUTZE INC.

13330 South Ridge Drive • Charlotte, NC 28273, USA  
Tel. +1 (704) 504-0222 • Fax +1 (704) 504-0223  
www.lutze.com • info@lutze.com

United Kingdom: LÜTZE Ltd.

Unit 3, Sandy Hill Park  
Sandy Way, Amington • GB-Tamworth, Staffs B77 4DU  
Tel. +44 (0)1827 31333-0 • Fax +44 (0)1827 31333-2  
www.lutze.com • sales.gb@lutze.co.uk



## Technical data sheet - Actuator sensor interface

Class of flammability according to UL 94	V0
Protection class	67, in screwed condition
Housing material	PBT black
Contact material	CuZn, gold-plated
Thread material	CuSn nickel plated
Cable diameter	4 – 7.5 mm
Storage temperature range	-40 °C – 90 °C
Temperature range connector	-25 °C – 80 °C
Class of flammability according to UL 94	V0
Mechanical service life	>100 insertion cycles
Cross section	0.34–0.75 mm <sup>2</sup>
Weight (kg/piece)	0.030
Termination	IDC method of termination
PU	1

### Dimensions

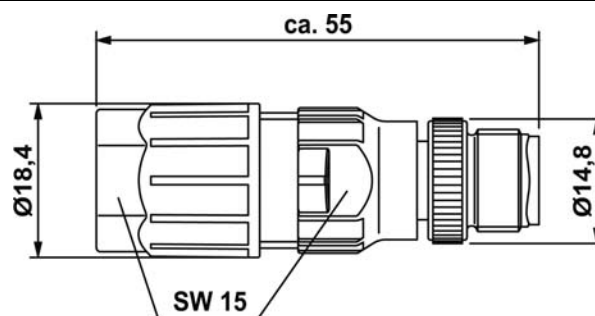

### Mounting diagram

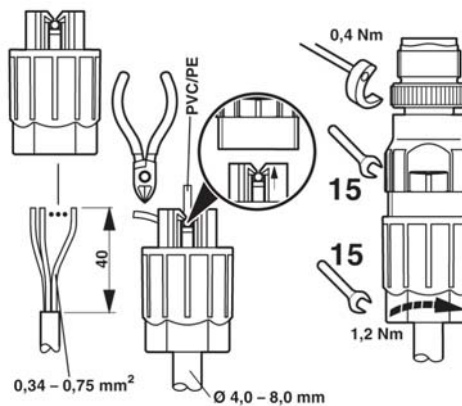

### Pin layout



14.11.2013 – Subject to technical modification

Part-No. 490028

USA: LUTZE INC.

13330 South Ridge Drive • Charlotte, NC 28273, USA  
 Tel. +1 (704) 504-0222 • Fax +1 (704) 504-0223  
 www.lutze.com • info@lutze.com

United Kingdom: LÜTZE Ltd.

Unit 3, Sandy Hill Park  
 Sandy Way, Amington • GB-Tamworth, Staffs B77 4DU  
 Tel. +44 (0)1827 31333-0 • Fax +44 (0)1827 31333-2  
 www.lutze.com • sales.gb@lutze.co.uk



SYSTEMATIC TECHNOLOGY